

The information on this document is the property of BHARAT HEAVY ELECTRICALS LIMITED. It must not be used directly or indirectly in any way detrimental to the interest of the company.

3-13-572-62-27-00
DRAWING No.

First Angle Projection

All dimensions are in MM

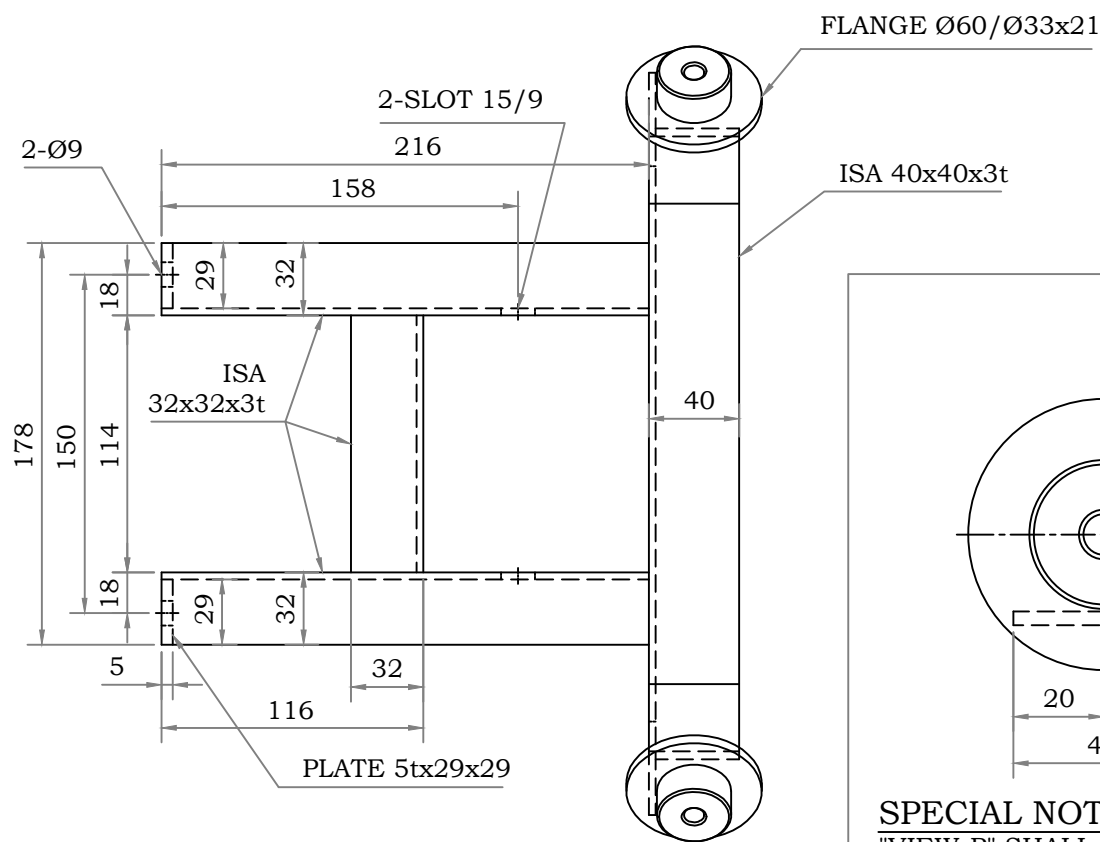
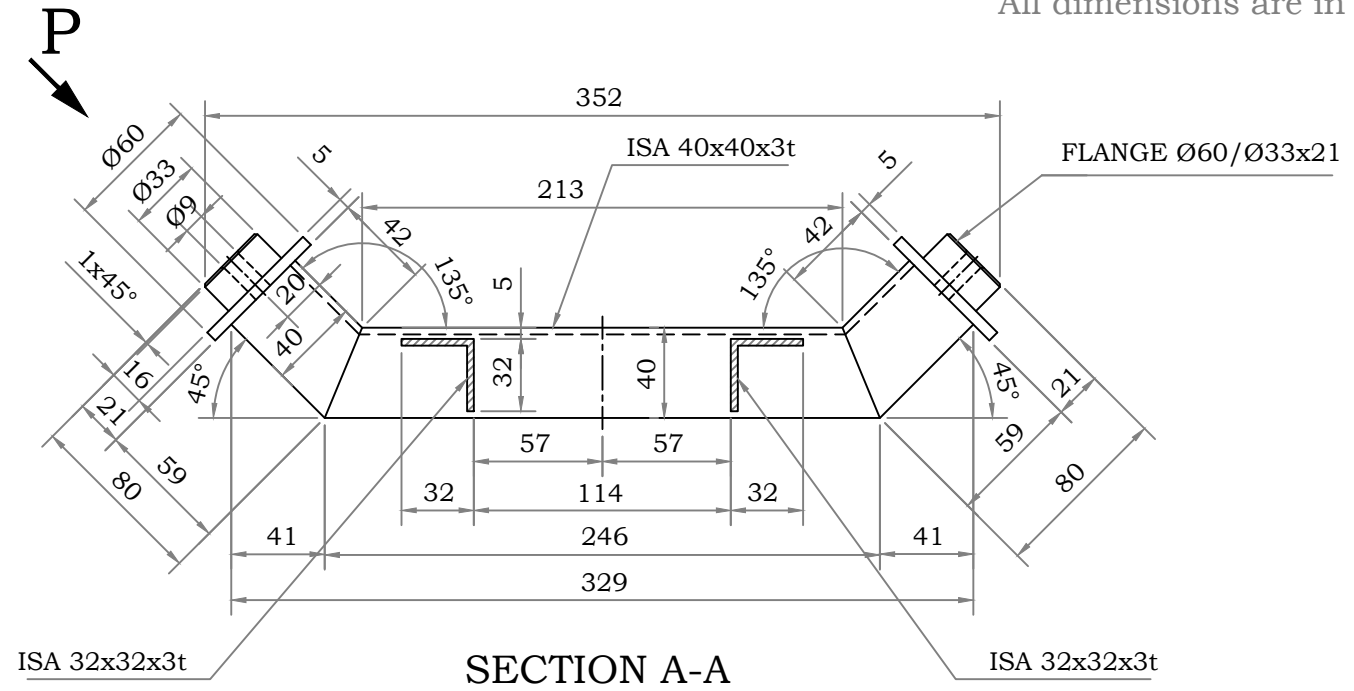
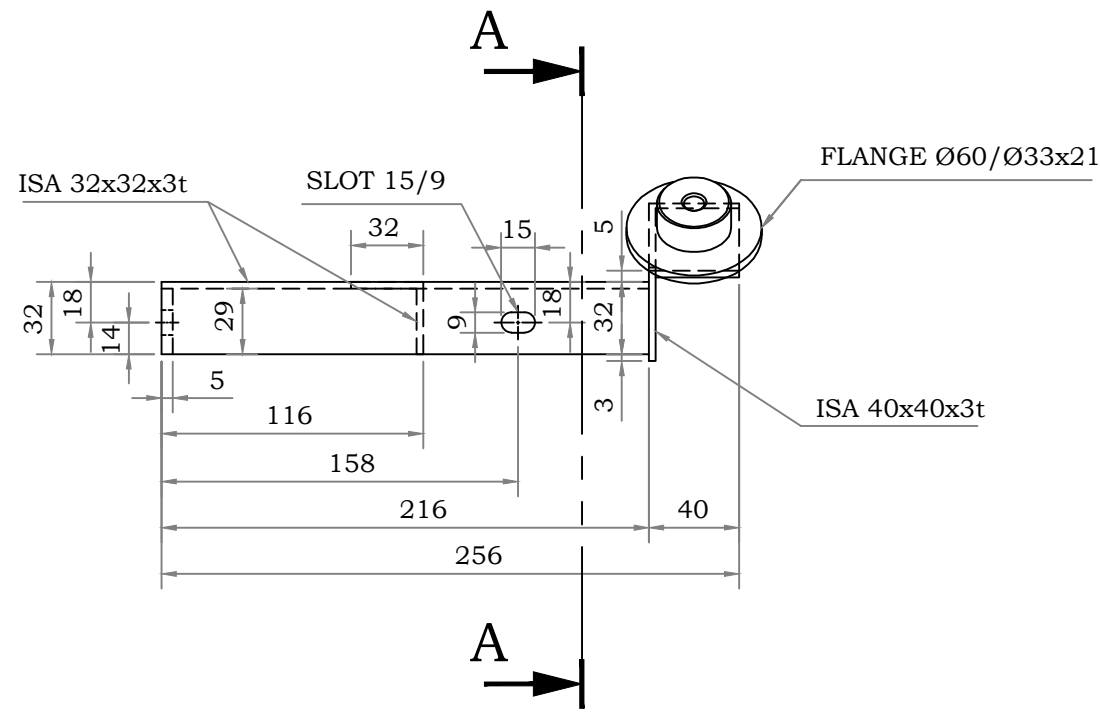

NOTE:

- 1) MATERIAL SHALL BE STRAIGHTENED BEFORE FABRICATION.
- 2) ALL JOINTS ARE TO BE WELDED UNLESS OTHERWISE SPECIFIED.
- 3) SHARP CORNERS/BURRS SHALL BE SMOOTHENED.
- 4) MATERIAL SHALL BE HOT DIP GALVANIZED.

MATERIAL : M.S.
QUANTITY : 72 Nos.

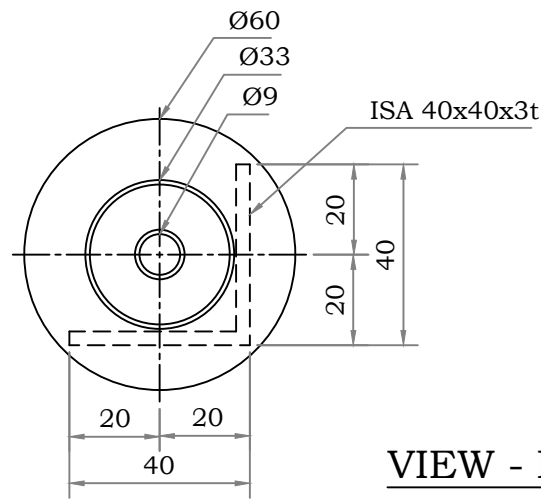

VIEW - P

SPECIAL NOTE:
"VIEW-P" SHALL BE MIRROR IMAGED WHILE WELDING OF FLANGE AT OTHER END.

ITEM No.	DESCRIPTION	DRAWING No.	MTL. SPCN. MTL. CODE	QTY.	UNIT WT. (Kg.)
TYPE OF PRODUCT OR NAME OF THE CUSTOMER/PROJECT Field Demonstration of 100 kWp SPV System with Solar Thermal Sun Trackers					
BHARAT HEAVY ELECTRICALS LTD. CORPORATE RESEARCH AND DEVELOPMENT		NAME	SIGN	DATE	No. OF VAR
DEPT FCR		DRN	KVPR RAO		
CODE 62		CKD	SURYA ASP		
		APPD	M R PAWAR		
MATERIAL M.S.	SCALE NTS	TOTAL WT. (Kg.)	REF. TO ASSY. DRG.	ITEM No.	No. OF ITEM
TITLE STOPPER BRACKET (50 kWp HORIZONTAL AXIS PASSIVE TRACKERS)			DRAWING No. 3-13-572-62-27-00	REV. 0	
			SHT. No.	No. OF SHTS.	