



## AMENDMENT -NOTIFICATION

AA 611 01 07

Rev. No. 00

PAGE 1 OF 1

### AA 611 01 07 : U-TYPE CLAMPS WITH ROUND FINGER (TYPE-B)

In **CI 4.1 of page 1 of 2**, the year reference of IS: 4293 is modified as **"IS: 4293-1984 (Reaffirmed 2000)"**.

Please see Instructions on the reverse.

Ref :	Amd No.	Approved	Issued	Date	Cum.Sr.No.
CI 30.5.07 of MOM of WG-TOOLS	01	WG - T	CORP. R&D	15.03.2003	A 3446



# CORPORATE STANDARD

AA 611 01 07

REV.No. 00

PAGE 1 OF 2

## U - TYPE CLAMPS WITH ROUND FINGER (TYPE - B)

### 1.0 SCOPE:

This standard covers the dimensions and other requirements for U-type clamps with round finger (Type B).

### 2.0 DESIGNATION:

A U-type clamp with round finger of type B having  $d = 14\text{mm}$  and  $l = 160\text{mm}$  shall be designated as:

2.1 On indents: U - type clamp B 14 x 160 - AA 611 01 07.

2.2 For issuing enquiries & Purchase orders: Delete the corporate standard No. from the above designation and add the information given under clause 4.0.

2.3 Abbreviated description: CLMP TYPE-U B 14 X 160

### 3.0 MATERIAL:

Steel suitably hardened and tempered to a tensile strength of 750 to 800 N/mm<sup>2</sup>.

### 4.0 COMPLIANCE WITH STANDARDS:

4.1 Dimensions, material, finish, packing, marking, etc.: To conform to IS: 4293 - 1984 / Reaffirmed 1990.

The information on this document is the property of BHARAT HEAVY ELECTRICALS LTD. It must not be used directly or indirectly in any way detrimental to the interest of the company.

Revision:			Approved: INTERPLANT STANDARDIZATION COMMITTEE-WG ( Tools )		
Rev.No.	Amd.No.	Reaffirmed	Prepared EDN B'LORE	Issued CORP. R&D	Dt. of 1st issue 1-3-96
Dt.	Dt.	Year:			

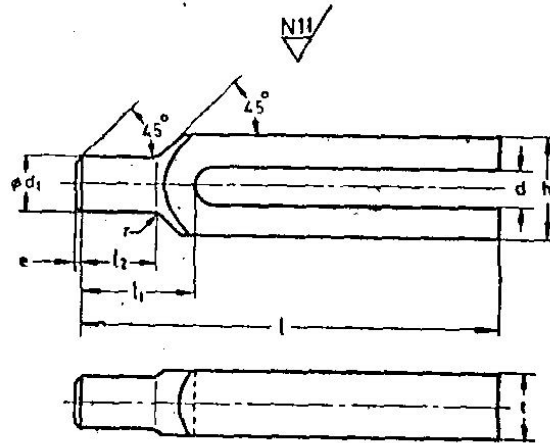

All dimensions in 'mm'

d H13	d1	e	t	l	l <sub>1</sub>	l <sub>2</sub>	r	h	For screw size	Sub-code
6.6	12	1.0	15	80	28	18	2.5	25	M6	018
9	100			30				30	M8	026
11	16			20				125	36	24
14	20	1.5	25	160	45	30	5.0	40	M12	042
				(200)						050
18	24	1.5	30	200	55	36	5.0	50	M16	069
				(250)						077
22	30	2.0	40	250	65	45	5.0	60	M20	085
				(315)						093
26	38	2.0	40	(250)	80	56	5.0	70	M24	107
				315						115