



ಭಾರತ್ ಹೆವಿ ಎಲೆಕ್ಟ್ರಿಕಲ್ಸ್ ಲಿಮಿಟೆಡ್  
भारत हेवी इलेक्ट्रिकल्स लिमिटेड

## Bharat Heavy Electricals Limited

(A Government of India Undertaking)

ELECTRONICS DIVISION

P.B. No 2606, Mysore Road,  
Bangalore - 560 026

*An ISO9001, ISO 14001 & OHSAS 18001 Company*

**Addendum for open tender RFQ No: LKK0000075 Dt. 25.04.2015 due Dt. 18.05.2015, Supply of SS Dining table and Stool.**

Following revision/ modifications are incorporated in Tender document-

### Pre-Qualification / Evaluation Criteria for Bidders:

Sl. No.	PARTICULARS	DETAILS
1.	Bidders shall have successfully executed jobs of similar nature with any Govt. organizations /PSU / Public Limited Company/ Private limited companies and shall submit the copies of the orders, for the past TWO Years	
2	The supplier should have supplied and installed Dining tables for industrial Canteen ( stainless steel / wooden / Polyurethane coated Cafeteria Tables or similar tables) to leading organizations. (Please provide order Copies for the supply of above)	
3	Performance / Commissioning Completion Certificate for the above	
4.	The bidder shall have a minimum average Turnover of Rs. 3,50,000.00 per year for the last three consecutive years. The Bidder shall submit Audited Balance Sheet and profit and loss account of the company for the last three consecutive years ending 31 <sup>st</sup> March 2014, for proof of turnover	
5	The bidder should be capable in respect of personnel equipment and manufacturing Facilities.	



SPECIFICATION FOR  
STAINLESSSTEELDINING TABLE  
AND STOOL  
(4 seater)

BHE/904/14-15/490 /TBL/DNG/SS

REV NO. 00

PAGE 1 of 5

REVISION HISTORY SHEET

REV NO.	DATE	NATURE OF CHANGE	REASONS	CHANGED BY	APPROVED BY
	17.04.2015	NEW		B.LINGAIAH	K.PARTHIBAN

PREPARED BY: B.LINGAIAH	APPROVED BY : K.PARTHIBAN	ISSUED BY: HUMAN RESOURCES DEPARTMENT /TOWNSHIP	DATE : 17/04/2015
----------------------------	------------------------------	--	----------------------

COPY RIGHT AND CONFIDENTIAL

The information in this document is the property of BHARAT HEAVY ELECTRICALS LIMITED  
It must not be used directly or indirectly in any way detrimental to the interest of the company



SPECIFICATION FOR  
STAINLESSSTEELDINING TABLE  
AND STOOL  
(4 seater)

BHE/904/14-15/490 /TBL/DNG/SS

REV NO. 00

PAGE 2 of 5

A. General:

This specification covers the requirements of Dining Table With Stool made out of stainless steel top, 4 seater capacity. These tables are proposed to provide in dining area of New community hall at Township, BHEL-Electronics Division, west of chord Road, Vijay nagar, Bangalore 560040 Bangalore located 2KM from BHEL EDN Factory.

The Product furnished under this specification shall meet or exceed the following requirements :

The Dining table , shall present a neat, well-finished appearance and shall be free of all imperfections and/or defects, which might affect appearance, normal life, or serviceability.

All Panels and accessories shall be furnished completely assembled and ready for use.

Details where ever not specified herein shall be in accordance with standard commercial practices for products of this type.

B. Technical Specification :

1.0 The Dining Table with four stool, in general shall have similar configuration as shown in the fig.1

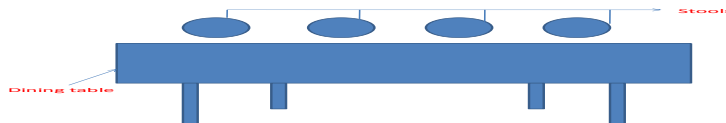

Fig. 1 SS Dining table and 4 stools



SPECIFICATION FOR  
STAINLESSSTEELDINING TABLE  
AND STOOL  
(4 seated)

BHE/904/14-15/490 /TBL/DNG/SS  
REV NO. 00  
PAGE 3 of 5

2.0 Dimensions:

The overall dimension of the dining table shall be as shown in the fig.2 below.

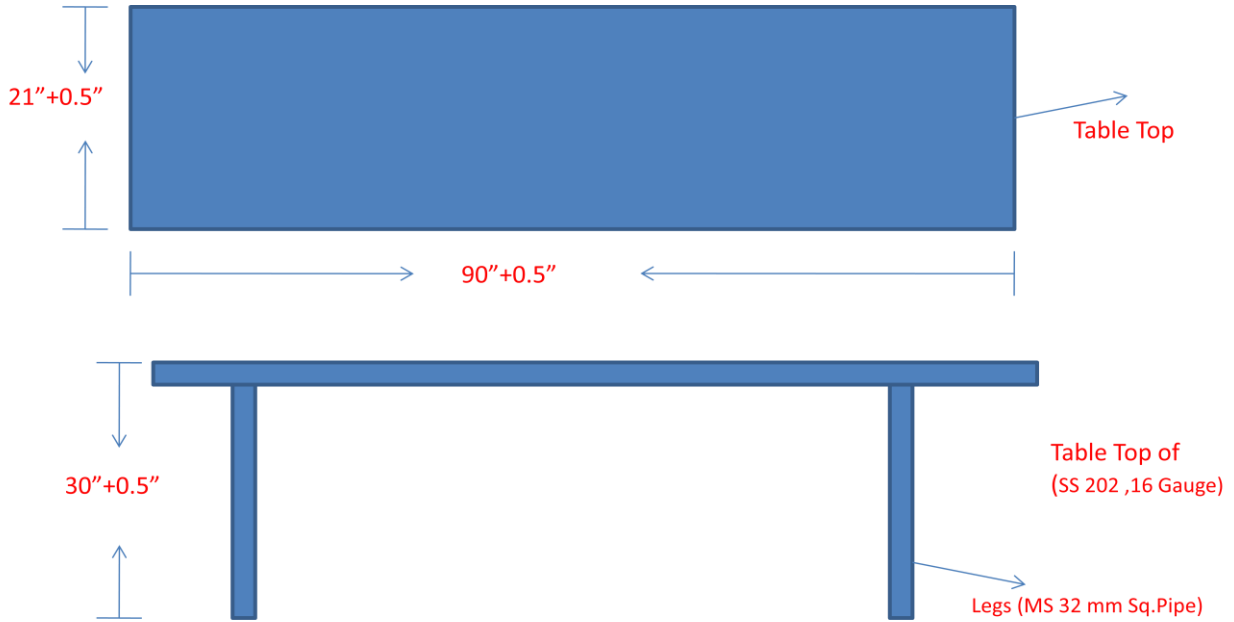

Fig .2 Typical Dimension of dining table

2.1. Table top shall be made up of SS 202, 16 gauge sheet folded to 25 mm thick, avoiding sharp edge and backed by 20mm Teak Wood/Beach Wood/Rubber wood/Particle Board. All the edges of work surface shall be neat polished/buffed to good finish. Work top shall be supported by wood of good quality with Stiffeners.

2.2 Over all dimensions (height, width and depth) shall have a tolerance of + 0.5 Inch

2.3 Cross section of table top:

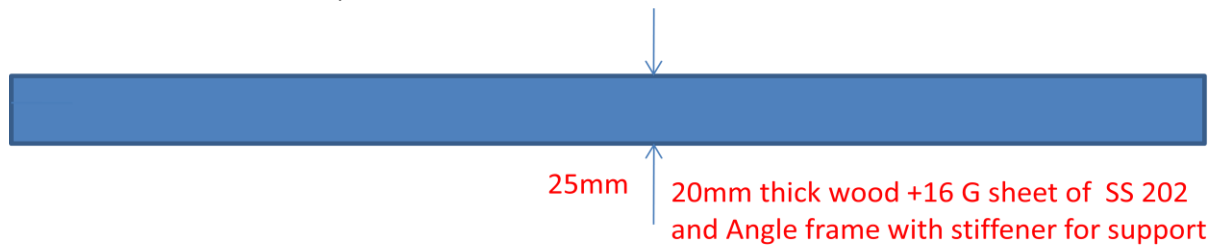

Fig.3 Table Top Details



SPECIFICATION FOR  
STAINLESSSTEELDINING TABLE  
AND STOOL  
(4 seater)

BHE/904/14-15/490 /TBL/DNG/SS

REV NO. 00

PAGE 4 of 5

2.4. Leg support:

The leg supports shall be of mild steel square tube of 32mm x 32mm, neatly welded and painted (Color shall be selected with the approval of BHEL) for durability following seven tank processes.

2.5 **SS Stool**

The Stool top shall be made up of 16 gauge stainless steel of dimensions as shown in the fig.4. All the surfaces shall be smooth finished &all the edges shall be neatly buffed/ polished so as to ensure free from the burr. The legs of stool should be fabricated rigidly to SS round top and spray painted.

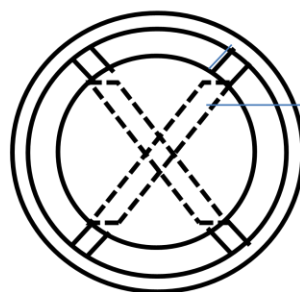
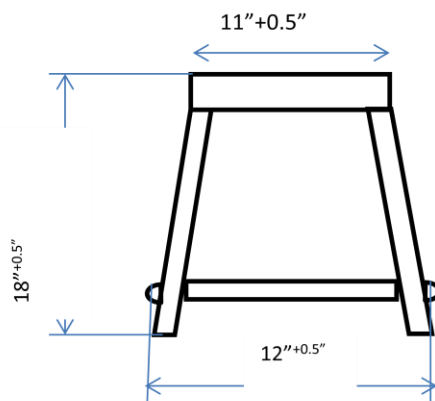

4 Nos. ½" pipe frame & leg fabricated with screw to SS round top and spray painted

Fig.4 SS Stool Detail



SPECIFICATION FOR  
STAINLESSSTEELDINING TABLE  
AND STOOL  
(4 seater)

BHE/904/14-15/490 /TBL/DNG/SS

REV NO. 00

PAGE 5 of 5

2.6. Leg support:

The leg shall be made up of mild steel pipes of 1.5mm to 2mm thick and painted with Polyurethane paint or epoxy powder coating.

3.0. Polishing:

All the surfaces shall be neatly polished /Buffed to mirror finish (Stain less steel).

3.1Color:

The color of the table top shall be of mirror finish silver (stainless steel)

4.0 Commissioning:

The scope includes Erection & Commissioning of the equipment at BHEL, Electronics Division Township, Vijayanagar, Bangalore 560040.

5.0 Guarantee:

One year from the date of commissioning for trouble free Operation.

6.0 Reference:

Customer's reference list and value of supply shall be furnished

7.0 General Maintenance Requirements

- a) Operation, maintenance and spare parts manual shall be supplied in triplicate along with the equipment.
- b) List of recommended spares for two years with price list to be provided along with the offer.
- c) All service requirements like power, air etc. if applicable has to be listed and intimated well in advance.
- d) Training for operation and maintenance personnel have to be arranged.
- e) All components should be of reputed make and easily available in the market.
- f) Supplier has to offer guarantee/ warranty for a period of one year from the date of commissioning and handling over.

**All are requested to quote in line with the addendum.**

**All other terms and conditions of RFQ remain unchanged.**