

NOTE :

- 1- ALL DIMENSIONS ARE IN mm UNLESS OTHERWISE SPECIFIED
- 2- DIMENSIONS ARE SUBJECT TO ±50mm VARIATIONS.
- 3- TYPE & DUTY E.W.R.H CLASS - II AS PER IS:3938
- 4- POWER SUPPLY 415V±5%, 50 HZ & CONTROL SUPPLY 110V
- 5- LOAD TEST AS PER IS:3938

LOCATION.	Vacuum Pump Motor Handling	Handling Oil Barrel In Central Lube Oil System	Control Fluid Room	Ventilation Plant Room	Ventilation Plant Room
HOIST CAP.	3T	3T	3T	3T	3T
MODEL NO	RH2	RH2	RH2	RH2	RH2
BHEL EQUIPMENT NO	EH-030306S	EH-030306S	EH-030306S	EH-030306S	EH-030306S
REVA EQUIPMENT NO	2968.1	2968.8	2968.10,11,12	2968.15	2968.16
QTY.	1	1	3	1	1
CAPACITY (T)	3	3	3	3	3
DUTY CLASS	CLASS-II AS PER IS:3938				
HEIGHT OF LIFT (M)	3.0-6.0	3.0-6.0	3.0-6.0	3.0-6.0	3.0-6.0
HOISTING SPEED	△ 0.3-3.0 VVVF D	△ 0.3-3.0 VVVF D	△ 0.3-3.0 VVVF D	△ 0.3-3.0 VVVF D	△ 0.3-3.0 VVVF D
CT SPEED	16 MPM	16 MPM	16 MPM	16 MPM	16 MPM
MOTOR KW/QTY					
MH	2.2 /1	2.2 /1	2.2 /1	2.2 /1	2.2 /1
CT	0.55 /2	0.55 /2	0.55 /2	0.55 /2	0.55 /2
BRAKE SIZE/QTY					
MH	12/1	12/1	12/1	12/1	12/1
CT	6/2	6/2	6/2	6/2	6/2
GEAR BOX REDUCTION RATIO					
MH	83:1	83:1	83:1	83:1	83:1
CT	15:1	15:1	15:1	15:1	15:1
WIRE ROPE DRUM Ø/LENGTH	220/560	220/560	220/560	220/560	220/560
WIRE ROPE DIA/NO OF FALLS	9/4	9/4	9/4	9/4	9/4
CONSTRUCTION	6x36	6x36	6x36	6x36	6x36
MIN BREAKING LOAD	5.2 T	5.2 T	5.2 T	5.2 T	5.2 T
WHEEL DIA/QTY	100mm/6	100mm/6	100mm/6	100mm/6	100mm/6
WHEEL MATERIAL	EN8/EN9	EN8/EN9	EN8/EN9	EN8/EN9	EN8/EN9
SHEAVE DIAMETER	205 mm	205 mm	205 mm	205 mm	205 mm
RUNWAY BEAM SIZE	*	*	*	*	*
WT. OF HOIST	350 kg	350 kg	350 kg	350 kg	350 kg
TRAVEL LENGTH	21	5	10	8.5	24
NATURE OF PATH	STRAIGHT	STRAIGHT	STRAIGHT	STRAIGHT	STRAIGHT
DIMENSION A	1000	1000	1000	1000	1000
DIMENSION B	510	510	510	510	510
DIMENSION C	330	330	330	330	330
DIMENSION H	7000	7000	7000	7000	7000

DESCRIPTION		LOCATION	
		MAIN HOIST	CROSS TRAVEL
MOTOR	MAKE	CGL/KBL/LHP/BBL/ABB	
	TYPE/NO. OF STARTS, STOP PER HR	TEFC,SQ. CAGE,S4 CRANE DUTY, 40%CDF, 150St/Hr, CL-F INS., IP-55,415±10%,50±5%Hz., 4 POLE,Amb. Temp.40°C. SUITABLY DERATED FOR 50°C. AMB TEMP.	
BRAKE	QTY	1	1
	TYPE	EM DC DISC TYPE	
LIMIT SWITCH	MAKE	EMCO	
	TYPE/QTY	SNAP ACTION/02	2 WAY LEVER TYPE/01
GEAR BOX	MAKE	REVA	
	TYPE	HELICAL	
	MATERIAL	LOW CARBON ALLOY STEEL(20MnCr5,17MnCr5)	MEDIUM CARBON ALLOY STEEL
	LUBRICATION	OIL SPLASH	GREASE PACKED
HOOK	MAKE	SKF/NBC/NRB/FAG	
	TYPE/MATERIAL	ANTI-FRICTION DEEP GROOVE BALL BEARING/ S.A.S ROLLER BEARING	
WIRE ROPE DRUM	MAKE	HARMON MOHATA/SMIRTI FORGING/ SARVODYA FORGING/KARCHIWALA	
	MATERIAL	PLAIN SHANK CIRCULAR SECTION /CL-II, IS:1875, AS PER IS:15560 WITH SAFETY LATCH	
WIRE ROPE	BEARING	THRUST BALL BEARING	
	MAKE	USHA MARTIN	
WHEELS	TENSILE STRENGTH	180Kg/mm2	
	HARDNESS	170-190 BHN	
SHEAVE	BEARING	MAKE	SKF/ FAG/ NBC/NRB/NORMA/TATA
	TYPE	ANTI-FRICTION DEEP GROOVE BALL BEARING	
SHEAVE	MATERIAL	CI, Gr-FG 200, :IS 210	
	BEARING	MAKE	SKF/ FAG/ NTN/NRB/NORMA/TATA
TYPE	ANTI-FRICTION DEEP GROOVE BALL BEARING		

FOR APPROVAL

APPROVED
By ANJANI KUMAR at 10:40 am, Dec 22, 2010

Digitally signed by ANJANI KUMAR
DN: cn=ANJANI KUMAR, o=BHEL, ou=PEM, email=anjani@bhel.pem.co.in, c=IN
Date: 2010.12.22 10:41:06 +05'30'

GUJARAT STATE ELECTRICITY CORPORATION LIMITED
12000 SW, UNIT # 6, UDAI THERMAL POWER STATION

TCE CONSULTING ENGINEERS LIMITED

BHARAT HEAVY ELECTRICALS LTD
POWER SECTOR
PROJECT ENGINEERING MANAGEMENT
NEW DELHI

Reva Industries Ltd.
2968.1,8,10,11,12,15,16/GA/R1

GA DRG. OF ELECTRIC WIRE ROPE HOIST FOR RATE CONTRACT HOIST FROM 3M LIFT TILL 3M LIFT CAPACITY 3T

DEPT. NO. PE-VO-294-563-AD02(1 OF 2)
SHEET 1 OF 4

DATA SHEET

DESCRIPTION	LOCATION	
	MAIN HOIST	CROSS TRAVEL
MOTOR	MAKE	CGL/KBL/LHP/BBL/ABB
	TYPE/NO. OF STARTS, STOP PER HR	TEFC, SQ. CAGE, S4 CRANE DUTY, 40% CDF, 150St/Hr, CL-F INS., IP-55, 415±10%, 50±5% Hz., 4 POLE, Amb. Temp. 40°C. SUITABLY DERATED FOR 50°C. AMB TEMP.
BRAKE	QTY	1
	TYPE	EM DC DISC TYPE
	MAKE	EMCO
LIMIT SWITCH	TYPE/QTY	SNAP ACTION/02 2 WAY LEVER TYPE/01
	MAKE	BCH/SOC.
GEAR BOX	MAKE	REVA
	TYPE	HELICAL
	MATERIAL	LOW CARBON ALLOY STEEL (20MnCr5, 17MnCr5) MEDIUM CARBON ALLOY STEEL
	LUBRICATION	OIL SPLASH GREASE PACKED
	BEARING	MAKE TYPE SKF/NBC/NRB/FAG ANTI-FRICTION DEEP GROOVE BALL BEARING/ S.A.S ROLLER BEARING
HOOK	MAKE	HARMON MOHATA/SMIRTI FORGING/SARVODYA FORGING/KARCHIWALA
	TYPE/MATERIAL	PLAIN SHANK CIRCULAR SECTION /CL-II, IS:1875, AS PER IS:15560 WITH SAFETY LATCH
	BEARING	THRUST BALL BEARING
WIRE ROPE DRUM	MATERIAL	SEAMLESS PIPE, ASTM A106/53, GR-A/B
WIRE ROPE	MAKE	USHA MARTIN
	TENSILE STRENGTH	180Kg/mm2
	HARDNESS	170-190 BHN
WHEELS	BEARING	MAKE TYPE SKF/ FAG/ NBC/NRB/NORMA/TATA ANTI-FRICTION DEEP GROOVE BALL BEARING
SHEAVE	MATERIAL	CI, Gr-FG 200, IS 210
	BEARING	MAKE TYPE SKF/ FAG/ NTN/NRB/NORMA/TATA ANTI-FRICTION DEEP GROOVE BALL BEARING

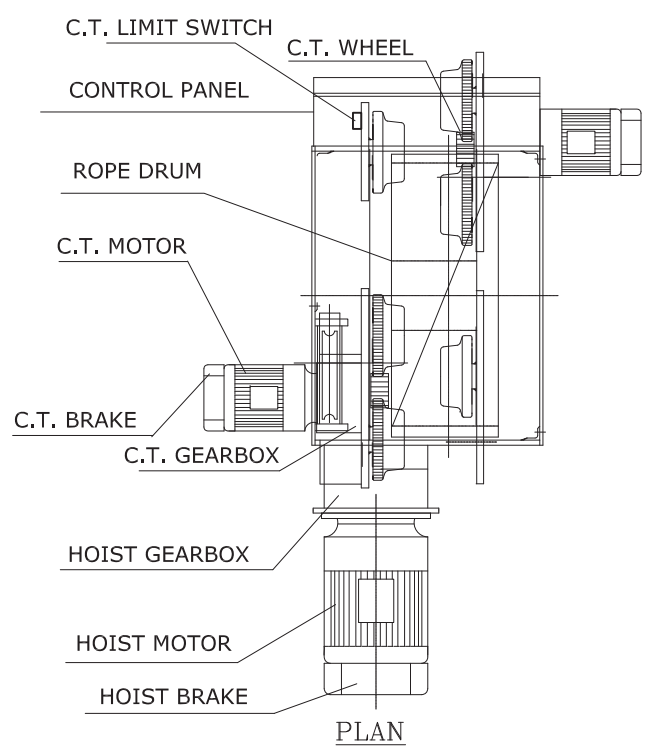
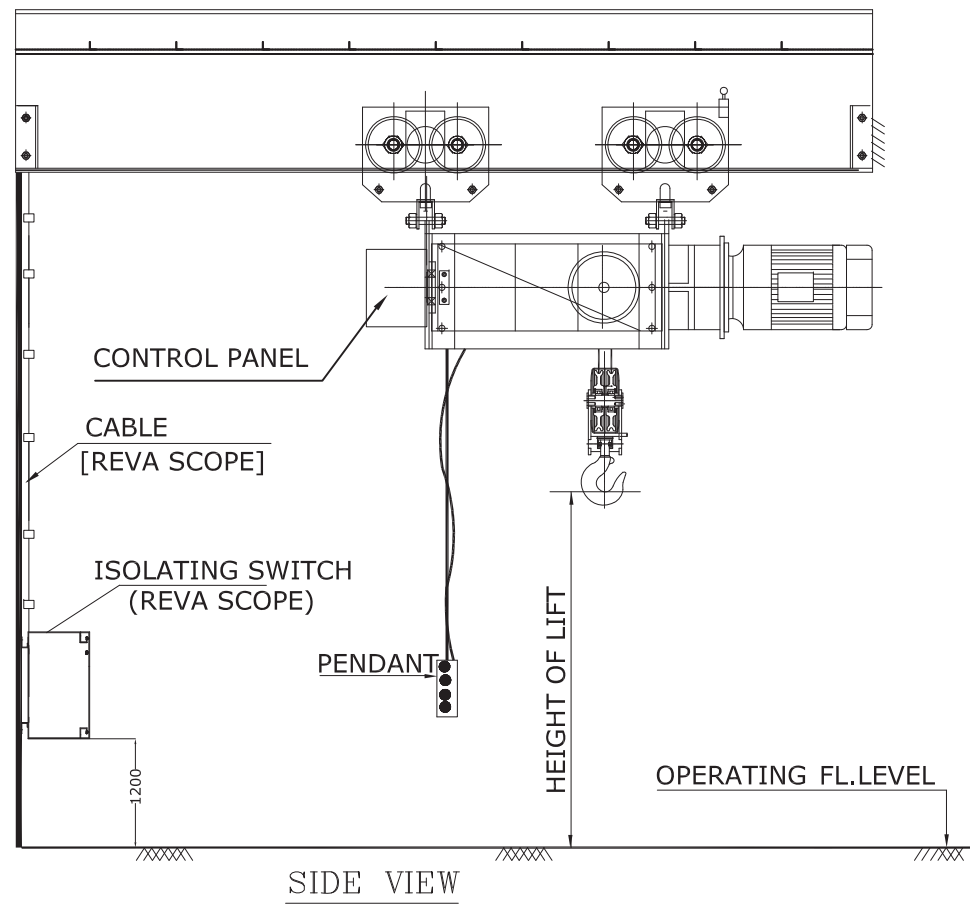
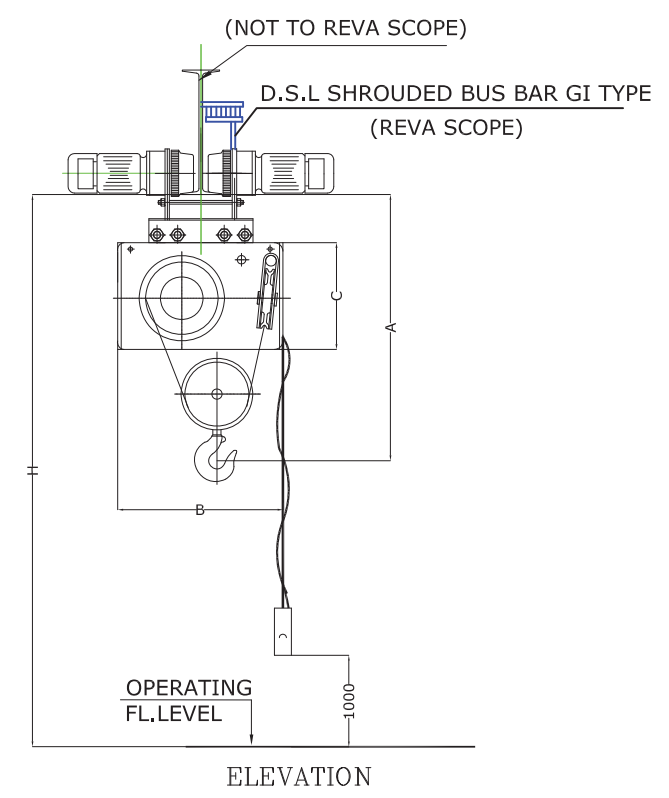

LOCATION.	DMCW Pump Motor Handling- TG	DMCW Pump Motor Handling- SG
HOIST CAP.	5T	5T
MODEL NO	RH3	RH3
BHEL EQUIPMENT NO	EH-050306S	
REVA EQUIPMENT NO	2968.2	2968.3
QTY.	1	1
CAPACITY (T)	5	5
DUTY CLASS	CLASS-II AS PER IS:3938	
HEIGHT OF LIFT (M)	3.0-6.0	3.0-6.0
HOISTING SPEED	△ 0.3-3.0 VVVF D	△ 0.3-3.0 VVVF D
CT SPEED	16 MPM	16 MPM
MOTOR KW/QTY		
MH	3.7 /1	3.7 /1
CT	0.55 /2	0.55 /2
BRAKE SIZE/QTY		
MH	14/1	14/1
CT	6/2	6/2
GEAR BOX REDUCTION RATIO		
MH	105:1	105:1
CT	15:1	15:1
WIRE ROPE DRUM Ø/LENGTH	280/540	280/540
WIRE ROPE DIA/NO OF FALLS	11/4	11/4
CONSTRUCTION	6x36	6x36
MIN BREAKING LOAD	7.7 T	7.7 T
WHEEL DIA/QTY	100mm/6	100mm/6
WHEEL MATERIAL	EN8/EN9	EN8/EN9
SHEAVE DIAMETER	205 mm	205 mm
RUNWAY BEAM SIZE	*	*
WT. OF HOIST	350 kg	350 kg
TRAVEL LENGTH	21	8.5
NATURE OF PATH	STRAIGHT	STRAIGHT
DIMENSION A	1100	1100
DIMENSION B	600	600
DIMENSION C	415	415
DIMENSION H	7100	7100

- NOTE :
- 1- ALL DIMENSIONS ARE IN mm UNLESS OTHERWISE SPECIFIED
 - 2- DIMENSIONS ARE SUBJECT TO ±50mm VARIATIONS.
 - 3- TYPE & DUTY E.W.R.H CLASS - II AS PER IS:3938
 - 4- POWER SUPPLY 415V±5%, 50 Hz & CONTROL SUPPLY 110V
 - 5- LOAD TEST AS PER IS:3938

APPROVED
By ANJANI KUMAR at 10:37 am, Dec 22, 2010

FOR APPROVAL

Digitally signed by ANJANI KUMAR
DN: cn=ANJANI KUMAR, o=BHEL, ou=PEM, email=anjani@bhhelpem.co.in, c=IN
Date: 2010.12.22 10:38:30 +05'30'

GUJARAT STATE ELECTRICITY CORPORATION LIMITED
1500 MW, UNIT @ 6, UKAI THERMAL POWER STATION

TCE CONSULTING ENGINEERS LIMITED

Reva Industries Ltd.
2968.2,3/GA/R1

GA DRG. OF ELECTRIC WIRE ROPE HOIST FOR RATE CONTRACT HOIST FROM 3M LIFT TILL 6M LIFT CAPACITY 5T

PE-VO-294-563-A002

REVISIONS

REV.	DATE	ALTD	CHD	APPD
2				

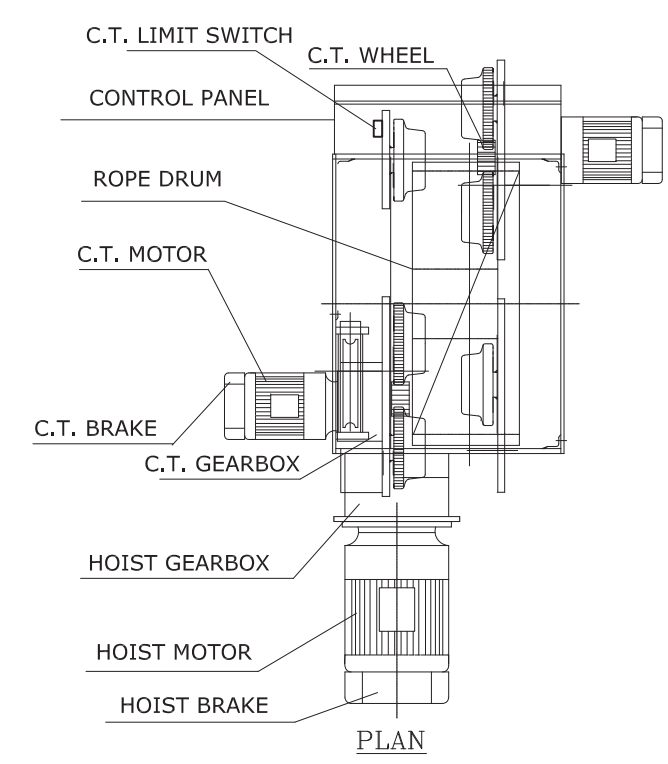
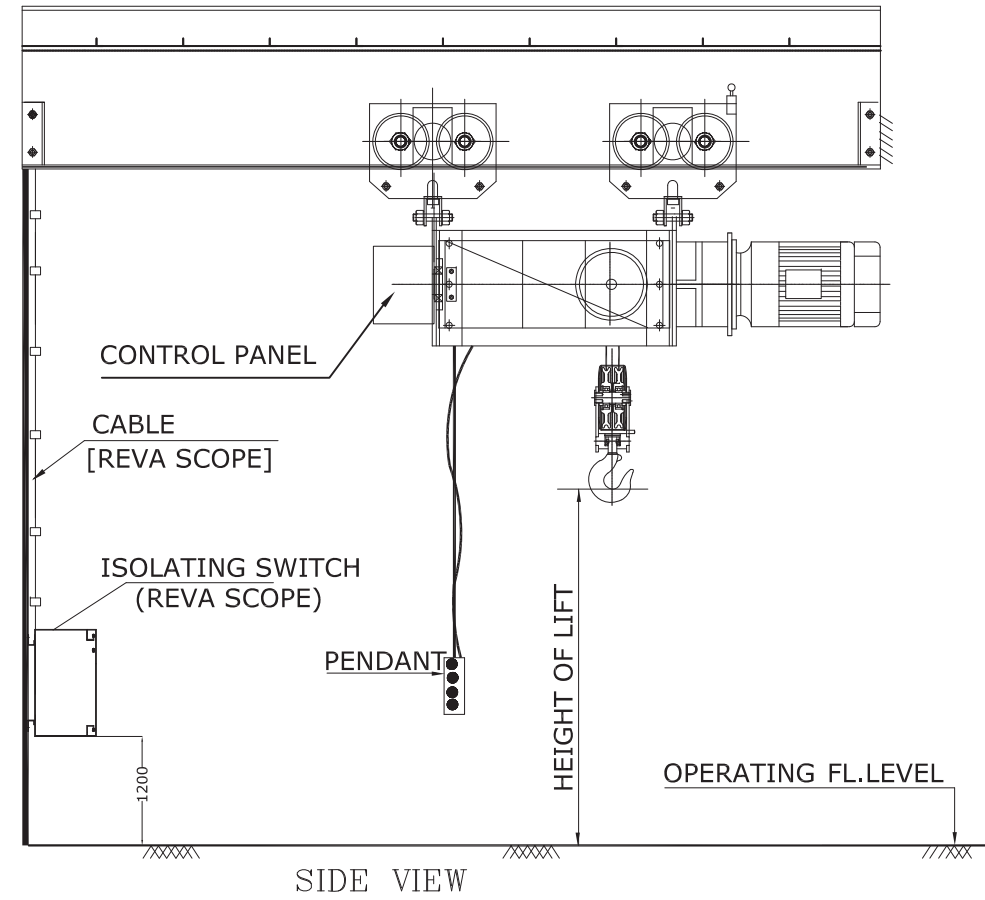
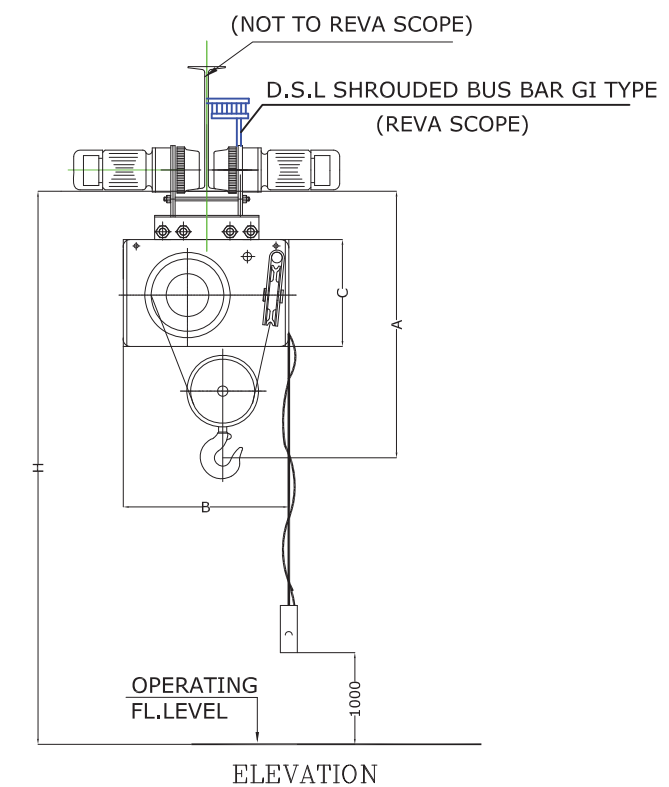

DESCRIPTION		LOCATION	
		MAIN HOIST	CROSS TRAVEL
MOTOR	MAKE	CGL/KBL/LHP/BBL/ABB	
	TYPE/NO. OF STARTS, STOP PER HR	TEFC, SQ. CAGE, S4 CRANE DUTY, 40% CDF, 150SU/Hr, CL-F INS., IP-55, 415±10%, 50±5% Hz., 4 POLE, Amb. Temp. 40°C. SUITABLY DERATED FOR 50°C. AMB TEMP.	
BRAKE	QTY	1	1
	TYPE	EM DC DISC TYPE	
LIMIT SWITCH	MAKE	EMCO	
	TYPE/QTY	SNAP ACTION/02	2 WAY LEVER TYPE/01
GEAR BOX	MAKE	BCH/SOC.	
	TYPE	HELICAL	
	MATERIAL	LOW CARBON ALLOY STEEL (20MnCr5, 17MnCr5)	MEDIUM CARBON ALLOY STEEL
	LUBRICATION	OIL SPLASH	GREASE PACKED
	BEARING	MAKE	SKF/NBC/NRB/FAG
HOOK	TYPE	ANTI-FRICTION DEEP GROOVE BALL BEARING/ S.A.S ROLLER BEARING	
	MAKE	HARMON MOHATA/SMIRTI FORGING/ SARVODYA FORGING/KARCHIWALA	
	TYPE/MATERIAL	PLAIN SHANK CIRCULAR SECTION /CL-II, IS:1875, AS PER IS:15560 WITH SAFETY LATCH	
WIRE ROPE DRUM	BEARING	THRUST BALL BEARING	
	MATERIAL	SEAMLESS PIPE, ASTM A106/53, GR-A/B	
WIRE ROPE	MAKE	USHA MARTIN	
	TENSILE STRENGTH	180Kg/mm ²	
WHEELS	HARDNESS	170-190 BHN	
	BEARING	MAKE	SKF/ FAG/ NBC/NRB/NORMA/TATA
SHEAVE	TYPE	ANTI-FRICTION DEEP GROOVE BALL BEARING	
	MATERIAL	CI. Gr-FG 200, :IS 210	
SHEAVE	MAKE	SKF/ FAG/ NTN/NRB/NORMA/TATA	
	TYPE	ANTI-FRICTION DEEP GROOVE BALL BEARING	

LOCATION.	AC Plant Room	For Elevator M/c Room In TG HALL	Elevator M/c Room In ESP Building
HOIST CAP.	3T	3T	3T
MODEL NO	RH2	RH2	RH2
BHEL EQUIPMENT NO	EH-030709S	EH-031012S	EH-031012S
REVA EQUIPMENT NO	2968.14	2968.13	2968.17
QTY.	1	1	1
CAPACITY (T)	3	3	3
DUTY CLASS	CLASS-II AS PER IS:3938		
HEIGHT OF LIFT (M)	7.0-9.0	10.0-12.0	10.0-12.0
HOISTING SPEED	0.3-3.0 VVVF D	0.3-3.0 VVVF D	0.3-3.0 VVVF D
CT SPEED	16 MPM	16 MPM	16 MPM
MOTOR KW/QTY			
MH	2.2 /1	2.2 /1	2.2 /1
CT	0.55 /2	0.55 /2	0.55 /2
BRAKE SIZE/QTY			
MH	12/1	12/1	12/1
CT	6/2	6/2	6/2
GEAR BOX REDUCTION RATIO			
MH	83:1	83:1	83:1
CT	15:1	15:1	15:1
WIRE ROPE DRUM Ø/LENGTH	220/730	220/910	220/910
WIRE ROPE DIA/NO OF FALLS	6x36 / 9/4	6x36 / 9/4	6x36 / 9/4
CONSTRUCTION	6x36	6x36	6x36
MIN BREAKING LOAD	5.2 T	5.2 T	5.2 T
WHEEL DIA/QTY	100mm/6	100mm/6	100mm/6
WHEEL MATERIAL	EN8/EN9	EN8/EN9	EN8/EN9
SHEAVE DIAMETER	205 mm	205 mm	205 mm
RUNWAY BEAM SIZE	*	*	*
WT. OF HOIST	400 kg	450 kg	450 kg
TRAVEL LENGTH	20	8	8
NATURE OF PATH	STRAIGHT	CURVED	CURVED
DIMENSION A	1000	1000	1000
DIMENSION B	510	510	510
DIMENSION C	330	330	330
DIMENSION H	10000	13000	13000

APPROVED
By ANJANI KUMAR at 5:10 pm, Dec 21, 2010

FOR APPROVAL

ANJANI KUMAR
Digitally signed by ANJANI KUMAR
DN: cn=ANJANI KUMAR, o=BHEL, ou=PEM, email=anjani@bhelpem.co.in, c=IN
Date: 2010.12.22 10:39:56 +05'30'

NOTE :
1- ALL DIMENSIONS ARE IN mm UNLESS OTHERWISE SPECIFIED
2- DIMENSIONS ARE SUBJECT TO ±50mm VARIATIONS.
3- TYPE & DUTY E.W.R.H CLASS - II AS PER IS:3938
4- POWER SUPPLY 415V±5%, 50 Hz & CONTROL SUPPLY 110V
5- LOAD TEST AS PER IS:3938

JOB NO. 026		STATUS CONTRACT		DISTRIBUTION		NO. OF REV. 2		DATE		ALD		CHD		APPO	
GSECL		GUJARAT STATE ELECTRICITY CORPORATION LIMITED		1x500 MW, UNIT # 6, UKAI THERMAL POWER STATION		TCE CONSULTING ENGINEERS LIMITED		BHARAT HEAVY ELECTRICALS LTD		POWER SECTOR		PROJECT ENGINEERING MANAGEMENT		NEW DELHI	
REVA		REVA INDUSTRIES LTD.		2968.13,14,17/GA/R1		GA DRG. OF ELECTRIC WIRE ROPE HOIST FOR RATE CONTRACT HOIST FROM 7M LIFT TILL 13M LIFT		CAPACITY 3T		DRAWING NO. PE-VO-294-563-A002 (2 OF 2)		SHEET 1 OF 4		REV.	

ELECTRONIC FILE NAME: FILE:R13R

DATA SHEET

DESCRIPTION	LOCATION	
	MAIN HOIST	CROSS TRAVEL
MOTOR	MAKE CGL/KBL/LHP/BBL/ABB	TEFC,SQ. CAGE,S4 CRANE DUTY, 40%CDF, 150S/Hr, CL-F INS., IP-55,415±10%,50±5%Hz., 4 POLE,Amb. Temp.40°C. SUITABLY DERATED FOR 50°C. AMB TEMP.
BRAKE	QTY	1
	TYPE MAKE	EM DC DISC TYPE EMCO
LIMIT SWITCH	TYPE/QTY	SNAP ACTION/02
	MAKE	BCH/SOC.
GEAR BOX	MAKE	REVA
	TYPE	HELICAL
	MATERIAL	LOW CARBON ALLOY STEEL(20MnCr5,17MnCr5)
	LUBRICATION	OIL SPLASH GREASE PACKED
BEARING	MAKE	SKF/NBC/NRB/FAG
	TYPE	ANTI-FRICTION DEEP GROOVE BALL BEARING/ S.A.S ROLLER BEARING
HOOK	MAKE	HARMON MOHATA/SMIRTI FORGING/ SARVODYA FORGING/KARCHIWALA
	TYPE/MATERIAL	PLAIN SHANK CIRCULAR SECTION /CL-II, IS:1875, AS PER IS:15560 WITH SAFETY LATCH
WIRE ROPE DRUM	MATERIAL	SEAMLESS PIPE, ASTM A106/53, GR-A/B
WIRE ROPE	MAKE	USHA MARTIN
	TENSILE STRENGTH	180Kg/mm2
WHEELS	HARDNESS	170-190 BHN
	BEARING	MAKE TYPE
SHEAVE	MATERIAL	CI. Gr-FG 200, :IS 210
	BEARING	MAKE TYPE

APPROVED
By ANJANI KUMAR at 5:04 pm, Dec 21, 2010

ANJANI KUMAR

Digitally signed by ANJANI KUMAR
DN: cn=ANJANI KUMAR, o=BHEL, ou=PEM, email=anjani@bhelpem.co.in, c=IN
Date: 2010.12.22 10:39:30 +05'30'

FOR APPROVAL

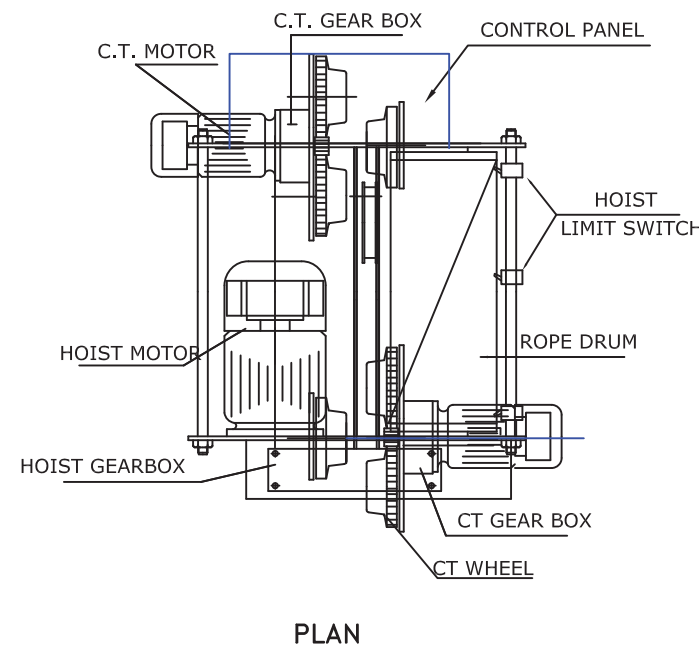
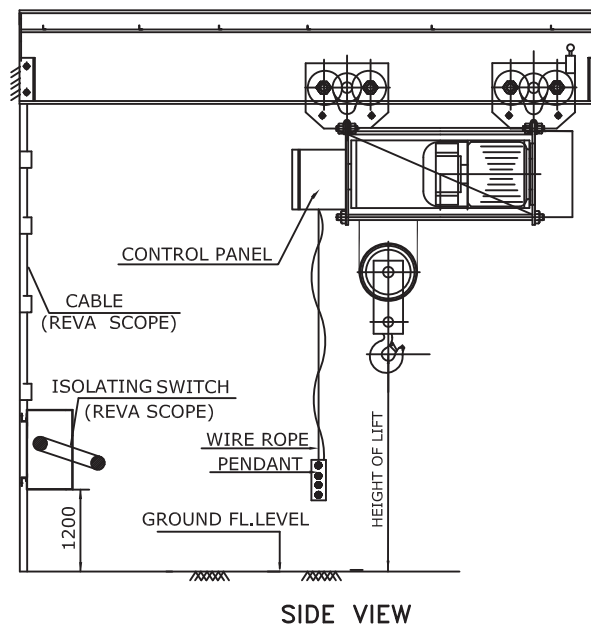
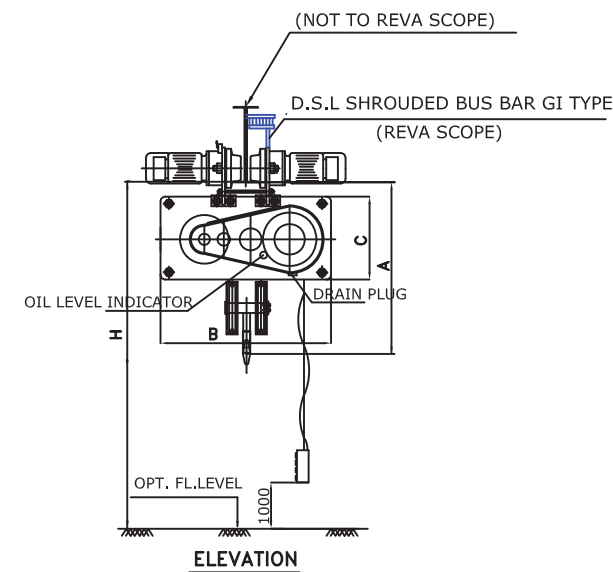

LOCATION.	Handling CW Butterfly Valves	CW Pit Gates & Screens
HOIST CAP.	10T	10T
MODEL NO	H4	H4
BHEL EQUIPMENT NO	EH-100306S	EH-101315S
REVA EQUIPMENT NO	2968.9	2968.6,7
QTY.	1	2
CAPACITY (T)	10	10
DUTY CLASS	CLASS-II AS PER IS:3938	
HEIGHT OF LIFT (M)	3.0-6.0	13.0-15.0
HOISTING SPEED	Δ 0.3-3.0 VVVF D	Δ 0.3-3.0 VVVF D
CT SPEED	16 MPM	16 MPM
MOTOR KW/QTY		
MH	7.5 /1	7.5 /1
CT	0.55 /2	0.55 /2
BRAKE SIZE/QTY		
MH	16/1	16/1
CT	6/2	6/2
GEAR BOX REDUCTION RATIO		
MH	120:1	120:1
CT	26:1	26:1
WIRE ROPE DRUM Ø/LENGTH	320/680	320/1325
WIRE ROPE DIA/NO OF FALLS	16/4	16/4
CONSTRUCTION	6x36	6x36
MIN BREAKING LOAD	16.41	16.41 T
WHEEL DIA/QTY	130/8	130/8
WHEEL MATERIAL	EN8	EN8
SHEAVE DIAMETER	315	315
RUNWAY BEAM SIZE	*	*
WT. OF HOIST	750 kg	1000 kg
TRAVEL LENGTH	10.5	28
NATURE OF PATH	STRAIGHT	STRAIGHT
DIMENSION A	1300	1300
DIMENSION B	950	950
DIMENSION C	500	500
DIMENSION H	7300	16300

- NOTE :
- 1- ALL DIMENSIONS ARE IN mm UNLESS OTHERWISE SPECIFIED
 - 2- DIMENSIONS ARE SUBJECTED TO ±50mm VARIATIONS.
 - 3- TYPE & DUTY E.W.R.H CLASS - II AS PER IS:3938
 - 4- POWER SUPPLY 415V±5%,50 Hz & CONTROL SUPPLY 110V
 - 5- LOAD TEST AS PER IS:3938

GUJARAT STATE ELECTRICITY CORPORATION LIMITED
1x500 MV, UNIT # 6, UKAI THERMAL POWER STATION

TCE CONSULTING ENGINEERS LIMITED

BHARAT HEAVY ELECTRICALS LTD
POWER SECTOR
PROJECT ENGINEERING MANAGEMENT
NEW DELHI

Reva Industries Ltd.
2968.6,7,9/GA/R1

GA DRG. OF ELECTRIC WIRE ROPE HOIST
FOR RATE CONTRACT HOIST FROM 3M LIFT TILL
15M LIFT CAPACITY 10T

DEPT. SCALE: SCALE DRAWING NO. PE-VO-294-563-A002
SHEET 4 OF 4

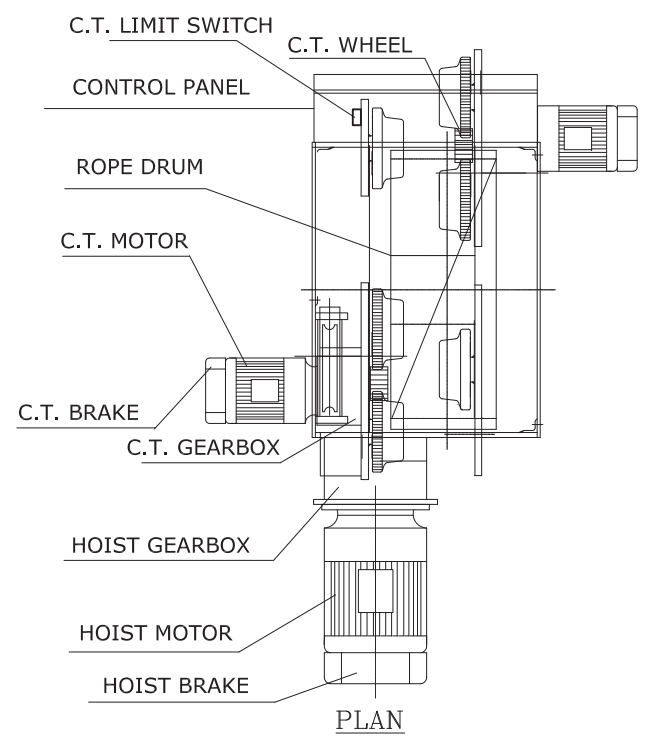
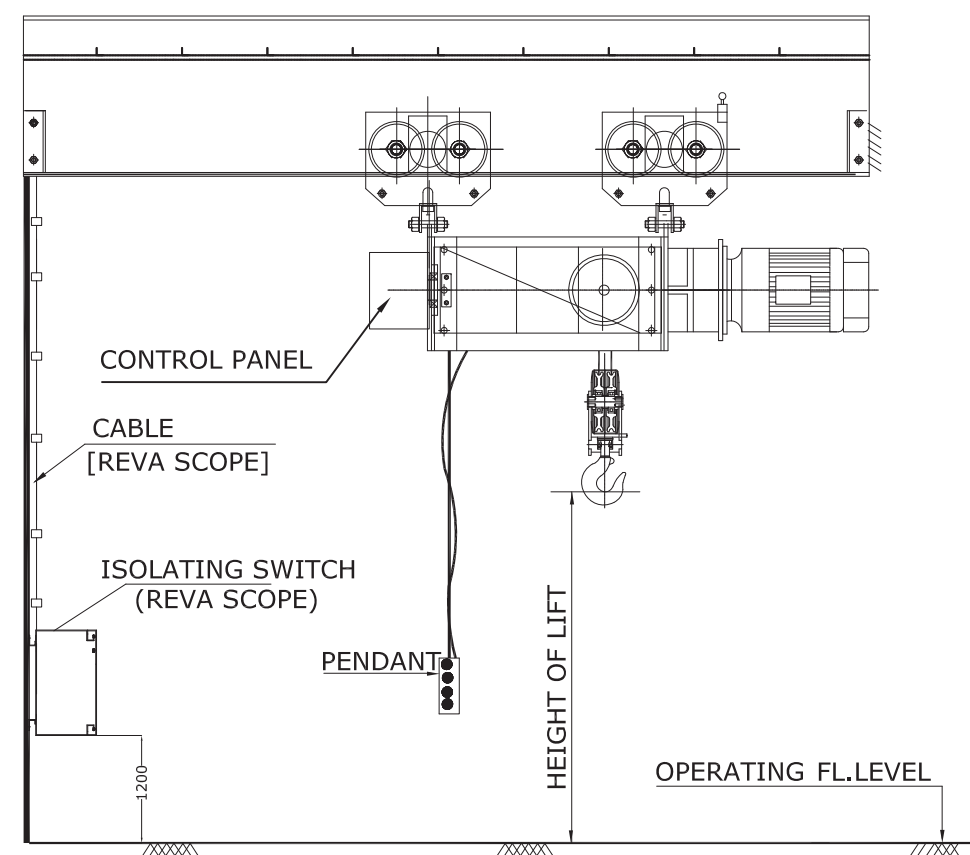
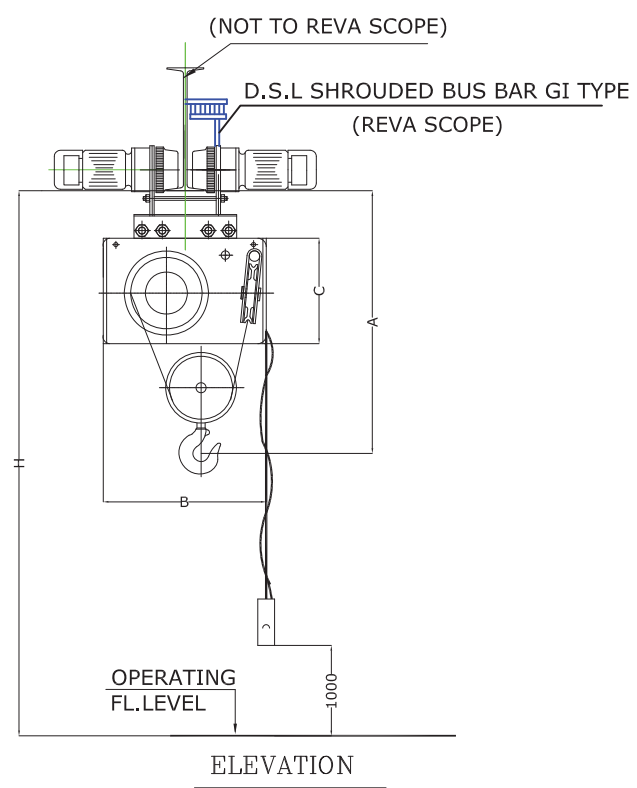

DESCRIPTION	LOCATION	
	MAIN HOIST	CROSS TRAVEL
MOTOR	MAKE TYPE/NO. OF STARTS, STOP PER HR	CGL/KBL/LHP/BBL/ABB TEFC, SQ. CAGE, S4 CRANE DUTY, 40% CDF, 150St/Hr, CL-F INS., IP-55, 415±10%, 50±5%Hz., 4 POLE, Amb. Temp. 40°C. SUITABLY DERATED FOR 50°C. AMB TEMP.
BRAKE	QTY	1
	TYPE MAKE	EM DC DISC TYPE EMCO
LIMIT SWITCH	TYPE/QTY	SNAP ACTION/02
	MAKE	BCH/SOC.
GEAR BOX	MAKE	REVA
	TYPE	HELICAL
	MATERIAL	LOW CARBON ALLOY STEEL (20MnCr5, 17MnCr5)
	LUBRICATION	OIL SPLASH
HOOK	MAKE	HARMON MOHATA/SMIRTI FORGING/SARVODYA FORGING/KARCHIWALA
	TYPE/MATERIAL	PLAIN SHANK CIRCULAR SECTION /CL-II, IS:1875, AS PER IS:15560 WITH SAFETY LATCH
WIRE ROPE DRUM	BEARING	THRUST BALL BEARING
	MATERIAL	SEAMLESS PIPE, ASTM A106/53, GR-A/B
WIRE ROPE	MAKE	USHA MARTIN
	TENSILE STRENGTH	180Kg/mm2
WHEELS	HARDNESS	170-190 BHN
	BEARING	MAKE TYPE
SHEAVE	MATERIAL	CI. Gr-FG 200, :IS 210
	BEARING	MAKE TYPE

LOCATION.	DG BUILDING
HOIST CAP.	8T
MODEL NO	RH3
BHEL EQUIPMENT NO	EH-080306S
REVA EQUIPMENT NO	2968.4,5
QTY.	2
CAPACITY (T)	8
DUTY CLASS	CLASS-II AS PER IS:3938
HEIGHT OF LIFT (M)	3.0-6.0
HOISTING SPEED	0.3-3.0 VVVF D
CT SPEED	16 MPM
MOTOR KW/QTY	
MH	7.5 /1
CT	0.55 /2
BRAKE SIZE/QTY	
MH	16/1
CT	6/2
GEAR BOX REDUCTION RATIO	
MH	105:1
CT	15:1
WIRE ROPE DRUM Ø/LENGTH	280/665
WIRE ROPE DIA/NO OF FALLS	14/4
CONSTRUCTION	6x36
MIN BREAKING LOAD	12.6 T
WHEEL DIA/QTY	130mm/6
WHEEL MATERIAL	EN8/EN8
SHEAVE DIAMETER	245 mm
RUNWAY BEAM SIZE	*
WT. OF HOIST	500 kg
TRAVEL LENGTH	12
NATURE OF PATH	STRAIGHT
DIMENSION A	1400
DIMENSION B	600
DIMENSION C	415
DIMENSION H	7400

CAT I -(APPROVED)

FOR APPROVAL

ANJANI KUMAR

Digitally signed by ANJANI KUMAR
DN: cn=ANJANI KUMAR, o=BHEL, ou=PEM, email=anjani@bhelpeem.co.in, c=IN
Date: 2012.04.04 11:04:27 +05'30'

- NOTE :
- 1- ALL DIMENSIONS ARE IN mm UNLESS OTHERWISE SPECIFIED
 - 2- DIMENSIONS ARE SUBJECT TO ±50mm VARIATIONS.
 - 3- TYPE & DUTY E.W.R.H CLASS - II AS PER IS:3938
 - 4- POWER SUPPLY 415V±5%, 50 Hz & CONTROL SUPPLY 110V
 - 5- LOAD TEST AS PER IS:3938

the bay length 15.0 M

JOB NO. 2968		STATUS CONTRACT		DISTRIBUTION		TO		NO. OF		REV.		DATE		ALD		CHD		APPO	
GSECL GUJARAT STATE ELECTRICITY CORPORATION LIMITED 14000 MW, UNIT # 6, UKAI THERMAL POWER STATION		TCE CONSULTING ENGINEERS LIMITED		BHARAT HEAVY ELECTRICALS LTD POWER SECTOR PROJECT ENGINEERING MANAGEMENT NEW DELHI		REVA INDUSTRIES LTD.		REVA DOC. NO. 2968.2.3/GA/R1		GA DRG. OF ELECTRIC WIRE ROPE HOIST FOR RAVE CONTRACT HOIST FROM 3M LIFT TILL 3M LIFT CAPACITY 8T		DEPT. SCALE SCALE DRAWING NO. PE-VO-294-563-A002		DATE		SHEET 3 OF 4		REV.	

ELECTRONIC FILE NAME: FILE:R11