



Bharat Heavy Electricals Limited
(Seamless steel Tube Plant)
Tiruchirappalli – 620014, TAMIL NADU, INDIA

TITLE: SUPPLY OF Snap Ring As per Drawing	Phone: +91 431 257 8480 Email : neerajxalxo@bheltry.co.in Web : www.bhel.com
--	---

Reference Number: 9240566 E	Date: 29.04.2014	Due date for submission of application: 21.05.2014
------------------------------------	-------------------------	---

BHEL/SSTP, Trichy is looking for vendors to supply of Snap Ring as per Drawing as per Tender documents attached.

A. Important Note to New Vendors

The new vendors will be required to furnish the following documentary proof/ information along with their offers:

1. Certificate of registration (copy of certificate to be submitted).
Spring manufacturer shall only be quote for this Tender. Facilities available with the vendor shall be enclosed with the Technical Bid itself.
2. Banker's information (copy of bank pass book first page to be submitted).
3. MSME vendor certificate (if applicable).
4. Address of your organization (complete postal address with PINCODE).
5. Contact person's Phone No. /Mobile No. / FAX No. /E-mail ID.
6. Statutory documents – VAT / TIN / EXCISE REGISTRATION / CST REGN / SERVICE TAX REGISTRATION etc. (copy to be furnished)
7. NSIC/SSI Certificate (if applicable)
8. ISO Certificate (if applicable)
9. Experience certificate as proof of supply of similar items to any Govt. agencies / PSU / Organisations (copy of PO's to be furnished).
10. Audit Report/ IT Return (if applicable)
11. Agency agreement with manufacturer (if applicable)
12. Partnership Deed (if applicable).

If the new vendors fail to submit the above documentary proof/information, their offers will not be considered for this enquiry.

Purchase Officer / Purchase /SSTP
Phone: 0431-257 8440.
Mail: neerajxalxo@bheltry.co.in



BHARAT HEAVY ELECTRICALS LIMITED
(A GOVERNMENT OF INDIA UNDERTAKING)
SEAMLESS STEEL TUBE PLANT
TIRUCHIRAPALLI - 620 014.
TAMILNADU (INDIA)

PHONE : 0431-2578480/8491
: 0431-2578406/8419
: 0431-2578568
FAX : 0431-2576828

TIN : 33243560005

CST. No. : 239383
Dated : 11.06.1991

PURCHASE ENQUIRY

VENDOR CODE	ENQUIRY NUMBER	ENQUIRY DATE	ENQUIRY DUE DATE	No. OF ITEMS
09152	9240566E	29/04/2014	21/05/2014	01

Office Copy

IMPORTANT POINTS :

1. Tender Closing Time : 14.00 Hrs.
2. Tender Opening Time : 15.00 Hrs.
3. Tender should be submitted in a sealed cover, duly indicating enquiry No. Enquiry date & Enquiry Due Date on the cover.
4. Offer(s) received through Courier Services after 14.00 Hrs. on Enquiry Due Date will not be considered.
5. Late Tender(s) is/are liable for rejection.
6. Offer(s) shall be valid for 60 days from Enquiry Due Date.
7. Offer(s) in Vendor's Letter head shall contain.
 - a. Offer No. and Date
 - b. Delivery Period
 - c. Delivery Terms
 - d. Payment Terms
 - e. Excise Duty with Tariff Heading Sales Tax (against form-XVII/Form-C), etc.
 - f. Excise Regn. No. and SSI Regn. No.

Kindly arrange to submit your COMPETITIVE OFFER for the following item(s)
If you are not in a position to submit your Offer, kindly arrange to send your REGRET LETTER.

THIS IS ONLY A REQUEST FOR OFFER AND NOT AN ORDER

No.	BHEL Material Code and Description	Unit	Requirement	
			Quantity	Delivery
01	BHEL Material Code : SP6906310162 SNAP RING FOR ADJ ROLL DRAWING NO. : 40.ST.192.02.593/02	Nos.	01 200.000	30/08/2014
<p>Foot Note ::</p> <ol style="list-style-type: none"> 1. This Tender is floated on TWO-BID basis. 2. Following details are enclosed. <ol style="list-style-type: none"> a. Annexure-A - Important Note to Tenderers. Tenderers are requested to submit their Offers in TWO-BID basis, viz., <ol style="list-style-type: none"> I. Part I .. Technical and Un-Priced Commercial Bid II. Part II .. Price Bid b. Annexure-B - Technical Conditions c. Annexure-C - Commercial Conditions 3. Tenderers are required to fill in above Annexure-B and C and enclose them along with their UN-PRICED BID. 4.a. Delivery date furnished in the Enquiry is only indicative. 4.b. For Delivery Schedule - Pl. refer Clause No. C.4 of Annexure- C. 5. Price Bid of Vendors, who accept the Clause No. B.1 to B.3 of Annexure-B & C.1 to C.5 of Annexure- C. shall only be considered for further processing. Fill the Annexure-B & C and enclose it with Technical and Un-Priced Commercial Bid. 6. Annexure-D Note to MSE Vendors enclosed. Send your MSE Certificate accordingly. 7. We highlight Clause Nos. 6 and 7 (LD and Risk Purchase) of Enquiry Terms and Conditions, printed overleaf. 				
<p>Indent Details</p> <p>Enq.Sl.No. Indt.No. Indt.Sl.No.</p>				

IMPORTANT NOTE :

Delivery Terms : "Free Delivery at BHEL-SSTP STORES" is preferable.
Payment Terms : 100% payment after 45 days after receipt and acceptance of materials by BHEL.
Terms and Conditions of Tender : Please see reverse.
The Technical Requirements/Specification Details/Quality Requirements/Commercial Terms & Conditions are clearly furnished in the Tender. If Deviation(s) is/are not explicitly brought out in the Offer, it will be construed that the Tenderer is complying with the requirement of BHEL in full without any deviation(s).

For and on behalf of
BHARAT HEAVY ELECTRICALS LTD.

PURCHASE EXECUTIVE

ALL DIMENSIONS ARE IN MM

REV	DATE	ALTERED
02	21.03.09	CHECKED
		APPROVED

0.8/

NOTE REVISED MATL. & DIMN.CHANGED

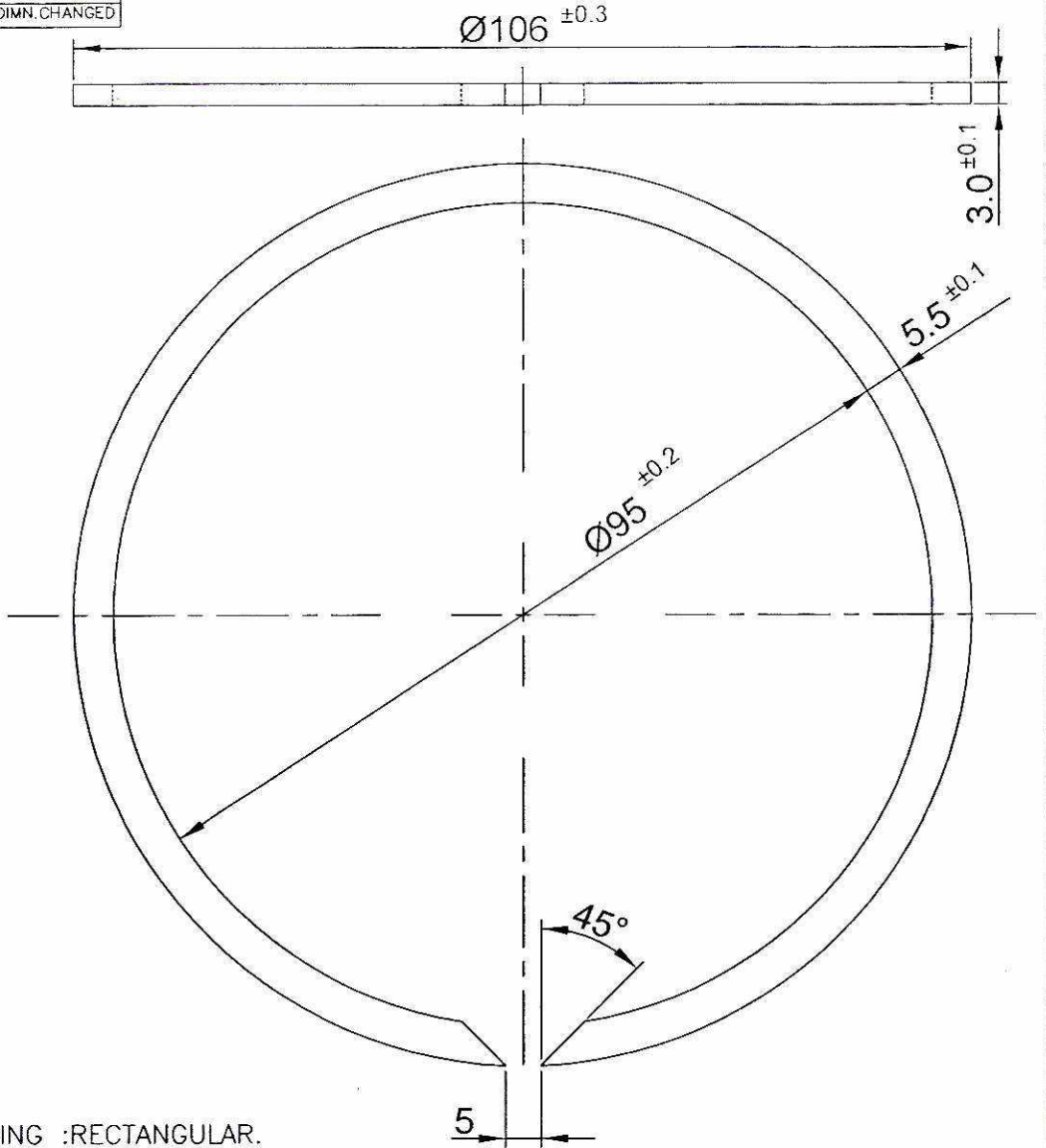

NOTE:

01) CROSS SECTION OF RING :RECTANGULAR.

02) CERTIFICATES FOR MATERIAL CHEMISTRY AND HARDNESS SHALL BE SENT WITH THE RINGS.

CHEMICAL COMPOSITION

C	Si	Mn	P	S
0.70	0.10	0.50	max.0.050	max.0.050
0.80	0.35	0.80		

HARDEN&TEMPER TO 350 - 475 HV(36-47HRC)

MATERIAL CODE No.:69 06 31 016 2

CAUTION: THE INFORMATION ON THIS DOCUMENT IS THE PROPERTY OF BHARAT HEAVY ELECTRICALS LIMITED.IT MUST NOT BE USED DIRECTLY OR INDIRECTLY IN ANY WAY DETRIMENTAL TO THE INTEREST OF THE COMPANY.

ITEM NO	DESCRIPTION	DRAWING NO	IS:2507-1975	
			Grade5 75C6	
			MATL CODE	UNIT WT
			MATL SPEC	QTY

EQPT:		DRN	NAME	SIGNATURE	DATE
 Bharat Heavy Electricals Ltd SEAMLESS STEEL TUBE PLANT TIRUCHIRAPALLI - 620014		R.KUMAR	R.Kumar		27.09.11
		CHD	N ARUMUGANAINAR	N. Arumuganainar	28.09.11
		APPD	S KARUPPASAMY	S Karuppasamy	01.10.11

DEPT	GRADE OF UNTOL. DIM	SCALE	WEIGHT (Kg)	REF TO ASSY DWG NO	ITEM
SSTP TE	φ/M/F	1:1	0.03	10-ST-192-02-033	24
CODE	IS: 2102			REF TO OLD DWG NO	
456				WR100	

TITLE	CARD CODE	DRAWING NO :	REV
SNAP RING (P B ADJ. ASSY)	U 01	40-ST-192-02-593	02

IMPORTANT NOTE TO TENDERERS
(FOR INDIGENOUS & OVERSEAS SUPPLIERS)

This Tender is floated on TWO–BID System. Tenders are requested to submit their offers in TWO-BIDS (Part I: Un priced bid and Part II: Price Bid) separately in a sealed cover as follows.

1. **Part I: UN PRICED BID:** (Complete with technical & Commercial conditions as per enquiry including un priced copy of price schedule i.e. identical to part II with prices blanked and replaced by “Quoted”) .

The Tenderer should confirm their acceptance / comments to the Enquiry along with other commercial Terms & Conditions of the Tender. In case any deviation is taken by the Tenderer from the Tender requirements, it is to be clearly indicated in the offer with reference to the particular clause. If such deviations are not explicitly indicated in the offer, it will be construed by BHEL that the Tenderer is complying with Annexure Clause(s), Commercial terms & conditions and other conditions in full.

2. **Part II: PRICE BID:** Price (with break-up details wherever required) to be indicated.
3. **Both Un priced Bid and Price Bid is** to be submitted in a single envelop before 1400 hours (Indian Time) on tender Due Date.
4. The **Unpriced Bid** shall be put in a separate sealed cover superscribed with Tender number, Tender Date & Tender Due Date and also the cover should be clearly marked with “UNPRICED BID”.
5. The **Price Bid** shall be put in a separate sealed cover superscribed with Tender number, Tender Date & Tender Due Date & the cover should be clearly marked with “PRICE BID”.
6. Both the individually enveloped **UNPRICED BID** and **PRICE BID** covers as mentioned above, have to be put in another single bigger cover clearly indicating Tender number, Tender Date & Tender Due Date at the top of the cover.
This cover is to be addressed to

Purchase Executive,
Purchase Department,
Seamless Steel Tube Plant (SSTP),
BHEL, Tiruchirapalli-620014, India.
Phone No: 91 431 2578502, 2578491

7. Unpriced Bid shall only be opened on the Tender Due Date mentioned in the Tender, in the presence of Tenderers / their Authorized Representative, who may like to be present for such opening. The price bid will NOT be opened on the date of tender opening.
8. After opening the Unpriced Bid, they shall be evaluated by BHEL for their suitability. BHEL shall hold discussions with the responded Tenderers on the Technical and Commercial terms and freeze the terms & conditions of the offer.. These frozen technical specifications will be communicated to responded tenderers.
9. BHEL shall offer opportunity to the responded and technically / commercially suitable Tenderers, to submit their latest Price Bid/ Impact of prices, if any in line with the frozen technical, Commercial, delivery conditions.
10. This latest Price Bid & the Impact of prices for the frozen technical specifications submitted by the Tenderers will be opened in the presence of Tenderers. Based on the above, the ranking of the Tenderers shall be made and accordingly the Tender shall be finalized.

Important Note to MSE Vendors

1. 20% of the tendered quantity is earmarked for MSE suppliers in this tender.
2. Out of the 20% tendered quantity reserved for MSE suppliers, 4% shall be earmarked for procurement from MSE owned by SC / ST entrepreneurs.
3. In case MSE vendor participating in the tender quotes within the price band of L1 + 15%, they will be allowed to supply the portion of the requirement subject to acceptance of L1 price by MSE vendor. In case of more than one such MSE, the supply shall be shared proportionately.
4. MSE suppliers can avail the intended benefits only if they submit along with offer, attested copies of either EM II certificate having deemed validity (Two years from the date of issue of acknowledgement in EM II) or valid NSIC certificate or EM II certificate along with CA certificate (Format enclosed) applicable for the year, certifying quantum of investment in plant and machinery within the permissible limit as per the act for relevant status (Micro or small) where the deemed validity of EM II is over. Date to be reckoned for determining the deemed validity will be the last date of technical bid submission. Non submission of such documents will lead to consideration of their bids at par with other bidders and MSE status of such suppliers shall be shifted to Non MSE supplier till the supplier submits these documents.

Certificate by Chartered Accountant

This is to Certify that M/S,
(hereinafter referred to as 'company') having its registered office at
..... is registered under MSMED Act 2006, (Entrepreneur
MeMemorandum No (Part—II).....dtd:.....,
Category: (Micro/Small)). (Copy enclosed).

Further verified from the Books of Accounts that the investment of the company as on
date as per MSMED Act 2006 is as follows:

1. **For Manufacturing Enterprises: Investment in plant and machinery** (i.e. original cost excluding land and building and the items specified by the Ministry of Small Scale Industries vide its notification No.5.0.1722(E) dated October 5, 2006:

Rs. Lacs

2. **For Service Enterprises: Investment in equipment** (original cost excluding land and building and furniture, fittings and other items not directly related to the service rendered or as may be notified under the MSMED Act, 2006:

Rs. Lacs

The above investment of Rs Lacs is within permissible limit of
Rs Lacs for Micro / Small (Strike off which is not applicable)
Category under MSMED Act 2006.

Date:

(Signature)

Name -

Membership number -

Seal of Chartered Accountant

Annexure – B.
Technical Conditions

Vendor Code:	Vendor Name:	
Tender No.:	Tender Date:	Tender Due Date:

Sl.No.	Technical Requirement	Accepted
B.1.	To supply of Materials as per Tender Specifications & Drawings without any Deviation	
B.2.	Dimension report will be sent along with the supply.	
B.3.	To supply of materials with suitable preservation and packing	
<u>Deviations, if any (attach additional sheet, if reqd) :</u> 		

Signature :

Date :

Seal :

Annexure – C.
Commercial Conditions

Vendor Code:	Vendor Name:	
Tender No.:	Tender Date:	Tender Due Date:

Sl.No.	Commercial Terms	Accepted				
C1.	<u>Delivery Terms</u> : Free delivery at BHEL/SSTP Stores.					
C2.	<u>Payment</u> : 100% after 45 days after receipt and acceptance of materials by BHEL					
C3.	<u>LIQUIDATED DAMAGES</u> : It is clearly understood among the parties to the Contract that TIME IS THE ESSENCE OF THE CONTRACT. Therefore, the delivery of the goods specified in the Purchase Order shall be made within the time prescribed. Where the Seller supplies or despatches the goods, beyond the delivery period specified, and the Purchaser will have no obligation to accept the goods. If accepted, Liquidated Damages at the rate of 0.5% (Zero point five Percent) of the value of goods delayed, per week of delay, subject to a maximum of 10% (Ten Percent) or part thereof, will be levied without prejudice to any other relief or compensation due to the Purchaser under any other conditions of the Contract. <u>RISK PURCHASE</u> : Alternatively, the Purchaser, at his option, will be entitled to terminate the Contract and to purchase elsewhere at the risk and cost of Seller, either the whole of the goods or any part, which the Seller has failed to deliver or dispatch within the time stipulated as aforesaid or if the same were not available the best and nearest available substitute thereof. The Seller shall be liable for any loss, which the Purchaser may sustain by reason of such Risk Purchase(s), in addition to penalty at the rate mentioned in Clause No.06 above.					
C4.	<u>Delivery Period</u> : <table border="1" style="margin-left: auto; margin-right: auto;"> <tr> <td>Delivery from PO Date</td> <td>Enq. Sl.No 1</td> </tr> <tr> <td>10 Weeks</td> <td>All Quantity</td> </tr> </table>	Delivery from PO Date	Enq. Sl.No 1	10 Weeks	All Quantity	
Delivery from PO Date	Enq. Sl.No 1					
10 Weeks	All Quantity					
C5.	<u>Validity</u> – 60 Days from the date of Tender Opening.					
<u>Deviations if any (attach additional sheet, if required) :</u>						

Sl.No.	Commercial Terms	
C6.	a. Excise Duty Tariff Heading	
	b. Excise Duty (%)	
	c. CESS on ED (%)	
	d. Total of ED and CESS (%)	
C7	a. TVNAT (%)	
	b. CST (%)	
C8.	Other Cost (if any) - % (or) Rs.	
C9	Are you Micro/Small/Medium Industry? (If YES, please furnish MSM Regn.No., along with a copy of MSM Certificate)	YES / NO MSM No. MSM Certificate enclosed(Yes/NO)

Signature with Date :
Seal :