



**BHARAT HEAVY ELECTRICALS LIMITED**  
**TIRUCHIRAPPALLI-620 014**  
**PLANT LABORATORY**

**SCOPE OF ENQUIRY**

ENQUIRY NO :	BHE:PL:Outsource:01:2013	
DUE FOR SUBMISSION OF THE OFFER	DATE	TIME
	<b>09.12.2013</b>	<b>14.00 Hrs (IST)</b>
DUE FOR OPENING OF THE OFFER	DATE	TIME
	<b>09.12.2013</b>	<b>14.30 Hrs (IST)</b>

**1.0 MATERIAL COLLECTION:**

1. All the Test samples like Raw Material Plates, Welders' Qualification Plates, Production Test Plates of FB, ATP, Valves etc. are to be collected by the FIRM at FIRMS' cost through Non Returnable Gate Pass from Plant Laboratory.

**2.0 TEST SPECIMEN CUTTING AND MACHINING:**

1. Specimen cutting is to be done by SAW cutting. No thermal cutting is permitted.
2. Various number of test specimens as shown under each enquiry Sl.No. are to be cut from the test plate.
3. For test specimen cutting sizes, refer the cutting plan sketches indicated against the each enquiry Sl.No.
4. Proper identification through MTL/INV/NS nos. and IBR/NTPC/TPI/Customer seals are to be transferred/preserved after specimen cutting, as required.
5. Machining operations like Turning, Milling, Surface Grinding and Notch broaching (wherever applicable) are to be carried out as per the test specimen preparation sketches shown against each enquiry no.
6. Proper identification with IBR/NTPC/Customer/TPI (whenever required) to be preserved in the balance pieces.

**3.0 INSPECTION:**

By QC-OLI/IBR/TPI/Customer and Plant Laboratory Personnel.

**4.0 DELIVERY:**

1. Completed prepared specimens and the balance materials with proper identifications are to be dispatched to Plant Laboratory through Delivery

Chalan along with Dimensional Report at FIRMS cost. Test specimens are to be completed within the target days as given below.

Sl.No	Description of Job	Target in Hours	Extra Time
1	Production Test Coupons	24 hours per set of three plates	More than 1 set, another 24 Hrs./set
2	Pre Production Test Coupon	24 hours per set of three plates	
3	Simulation Test Coupon	24 hours per set of three plates	
4	Welders' Qualification Test Coupons	120 hours for 75 (Plates/tubes/branches)	More than 75 nos. another 24 hrs./15 nos.
5	Procedure Qualification Test Coupon	72 Hours	
6	Raw Materials	72 Hours	
7	Investigation Samples	48 Hours	
8	Press Shop samples	48 Hours	
9	ATP Test Coupons	120 hours per 500 mm length	
10	Miscellaneous	72 hours	
11	MLP Block	8 hours	

**NOTE:** Rates should be quoted in the enclosed Enquiry Annexure format (Format for filling Price Bid) for all types of specimen shown under the each Enquiry Sl.No.

2. Rate per specimen and the sub total/job as in the format should be quoted for each Sl.No.
3. This is **Two Year** rate contract enquiry and the prices quoted shall be valid up to **31.12.2015**.
4. Purchase orders placement, material accounting, bills processing and allied activities will be carried out by the Plant Laboratory.
5. For any technical clarifications regarding specimen cutting, preparation and specimen sketches, contacts Shri. Dr.K.P.Dhandapani, Addl. General Manager, Plant Laboratory. Phone no.1293/2571293.
6. Bank guarantee deposit for an amount as indicated in Standard Terms and Condition- STAC (enclosed) to be made prior to the release of purchase order from Plant Laboratory.

## **5.0 SPECIAL INSTRUCTION TO THIS ENQUIRY:**

1. The firms shall have IBR approval to carry out specimen preparation work.
2. BHEL reserves the right to increase or decrease the tendered quantity and split the tendered quantity among more than one tendered and place orders accordingly in any proportion, based on commitment, requirement and suppliers' capability in terms of delivery and quality.
3. Lowest prices received against BHEL tenders need not be the technically acceptable L1 price and BHEL reserves the right not to consider the same.
4. BHEL reserves the right to negotiate or refloat the tender opened if L1 prices are not the lowest acceptable price to them inter-alia other reasons.
5. BHEL reserves the right to negotiate the L1 rate.
6. BHEL may order on more than one vendor at the lowest acceptable price to BHEL.
7. All the other terms and conditions shall be as per our STAC enclosed with this enquiry.

## **6.0 INSTRUCTONS FOR RESPONDING TO THIS TENDER:**

1. The Bidders shall submit the offer in a sealed envelope. This sealed envelope should contain the dully filled up Format for filling up Price Bid. (Format is enclosed with this enquiry)
2. The format categories the test coupons (test coupon could be plate, pipe, weld and so on) into 42 categories (indicated as Enq.No.1 to 42). Each Enq.No.has a set of Specimens, which are clearly indicated, along with the relevant specimen sketch number and number of specimens. The anticipated quantity for each of the Enq.No.to be totally prepared during the two years of the contract is indicated as the expected Quantity.
3. The Bidder has to fill up to the following without fail for all the 42 Enq.nos. **No item shall be left unquoted.**
  - Amount per specimen(example-cost of one Tr.Tensile or Tr.Bend or Macro Specimen preparation)in each of the 42 categories
  - Amount per test coupon (to be calculated based on the number of specimens [indicated] x quote for each type of specimen)

- Total amount ,which is calculated based on Amount per Test Coupon x Estimated Quantity
- Grand Total, Which is the Sum of the total amount for all the Enq.Nos.

The Bidder shall submit the offer in TWO INNER ENVELOPES as indicated below which shall be sealed in one outer envelope.

**Envelope I:** This sealed should contain all the copies of technical bid, commercial bid together with un-priced copy of price bid. This envelope should be clearly marked "**Part I – Technical and Commercial Bid**" indicating Enquiry No., due date, address and reference of the bidder.

**Envelope II:** This sealed envelope should contain Price details and should be clearly marked "**Part II – Price bid**", indicating enquiry number, due date, address and reference of the bidder.

4. Both the envelopes (Part I and Part II) shall be put in one cover, duly sealed, super scribing as Part I and Part II of enquiry number, due date of opening and the address and reference of the bidder.

5. The above offers should reach this office on or before the due date by 14.00 Hrs. (IST). Late offers will not be considered.

Tender should not be addressed to any individual's name but only by designation to:

**ADDL. GENERAL MANAGER/PLANT LABORATORY  
BHARAT HEAVY ELECTRICALS LIMITED  
HIGH PRESSURE BOILER PLANT  
TRICHIRAPPALLI-620014.  
TAMILNADU, INDIA.**

Tenders should be free from **CORRECTION AND ERASURES**. Corrections if any must be attested.

## **7.0 OPENING OF TENDERS:**

The Bid would be opened on 09.12.2013 at 14.30 Hours. in the presences of Tenders, who are present. Clarifications if any required by BHEL for Technical Evaluation would be sought from Bidders before opening price bid.

### **7.1 PART – I (TECHNICAL AND COMMERCIAL BID)**

7.1.1 Technical

This part shall include or indicate the following:

1. Firms shall have IBR approval to carry out specimen preparation work.
2. Offers shall contain complete details of machining facility availability, delivery and other commercial terms and conditions.
3. Point by point confirmation of our requirements given in Annexure I & II. If there is any deviation, the same should be clearly specified. Others received without confirmation to our specification will be rejected.
4. Information regarding mode of delivery of specimens shall be provided.
5. Delivery schedule as mentioned shall be strictly adhered to.
6. Offer validity shall be for a period of 2 years (Upto 31-12-2015).
7. A copy of "Un-Price bid Part-II:" i.e., a copy of Price Bid without the price details to be enclosed.

## **7.2 PART II (PRICE BID)**

This part should contain the schedule of price particulars and to be correlated to the technical details provided by Part I.

## **8.0 GENERAL**

1. Incomplete offers will not be considered.
2. **Fixed Price:** Rate quoted by the Bidder shall be fixed and not subject to any escalation whatsoever during the period of bid validity and execution of the Purchase order. A bid submitted with an adjustable rate will be treated as non-responsive and rejected. Rates shall be written in words and figures. In the event of difference, the rate in words shall be valid and binding. Unit rate shall be considered correct in the event of any discrepancy with regard to total rate.
3. **Taxes and Duties:** All Taxes and CST Payable as extra to the quoted Rate should be specifically stated in offers, failing which BHEL will not be liable for payment of such taxes.
4. **Earnest Money Deposit and Performance Bank Guarantee/ Security deposit:** As stated in our standard Terms and Condition (STAC).



BHARAT HEAVY ELECTRICALS LIMITED  
TIRUCHIRAPPALLI-620 014  
PLANT LABORATORY

PART I – TECHNICAL & COMMERCIAL BID  
CRITERION FOR EVALUATION OF SUB-CONTRACTOR  
FOR PREPARATION OF SPECIMENS FOR PLANT LABORATORY (2014-2015)

No	Facility required for doing BHEL jobs	Vendor's comments
<b>Location of machine shop</b>		
1	The machine shop for specimen preparation shall be located within 120 km radius from BHEL – Trichy unit.	
<b>Requirement of Machines</b>		
2	For SS/ Inconel clad plates, Q&T steels (Hardness > 25 HRC upto 60 HRC ) and high thickness ( $t > 25$ mm) welded /raw material plates - <b>Band Saw with bi-metallic blade and vice width of about 300 to 450mm.</b>	
3	For small thickness test plates ( $t \leq 25$ mm), tubulars ( $OD \leq 300$ mm) - <b>Power hacksaw.</b>	
4	<b>Lathe</b> to turn dia. 30 mm shoulder specimens	
5	<b>Universal milling machine</b> or vertical and horizontal milling machines	
6	<b>Alpha-Numeric Punching tool set</b> – both big & small	
7	Surface Grinding Machine Facility for Macro, Micro and Impact specimens	
8	Belt Grinder Facility	
9	V and U Notch Broaching Facility	
10	Facility for cutting hardened samples – like abrasive cut off machine (Hardness > 25 HRC upto 60 HRC )	
11	Profile Projector for checking the notch	
<b>Instruments for checking specimen dimensions</b>		
12	<b>Vernier calipers, micrometers</b> for measuring dimensions of materials supplied machined components/ prepared specimens <b>with calibration status.</b>	
<b>Chemicals</b>		
13	To enable etching of weldments to identify weld and HAZ, the firm should have a sink with water tap and	

	<b>macro-etching reagents for SS, carbon/low alloy steels and Titanium materials.</b>	
<b>Man Power Availability</b>		
14	<b>Sufficient manpower</b> (Artisans) to finish the test specimen preparation activity and deliver the samples and balance materials within the <b>stipulated time mentioned for each job order at Plant Laboratory.</b>	
<b>Space</b>		
15	Sufficient space for storing and carrying out machining, enabling easy identification & retrieval of materials and specimens machined, avoiding cramping and mix-up and to enable inspection at the firm's works.	
<b>Transport facility</b>		
16	The materials are to be collected and deposited back to Plant laboratory by the subcontractor. Facility to transport the same is required with the firm	
<b>Registration</b>		
17	The firm has IBR approval and is maintaining it.	

**PART II - FORMAT FOR FILLING UP PRICE BID**

**ANNEXURE TO ENQUIRY FOR SPECIMEN PREPARATION OUTSOURCING (2014-2015)**

**Note:** The Bidder has to fill up the following without fail for all the 42 Enq. No. items (indicated in Col.1).  
**None of the Enq. No. (as per col.1) and amount per type of specimen (as per col.6) shall be left unquoted, as it would lead to disqualification)**  
 - Col 6 ...Amount per specimen (example - cost of one Tr. Tensile or Tr. Bend or Macro specimen preparation) for each type of specimens under each of the 42 categories  
 - Col 7.... Amount per test coupon (to be calculated based on the number of specimens (indicated) x quote for each type of specimen)  
 - Col 8 ...Total amount, which is calculated based on (Amount per Test Coupon) x (Estimated Quantity given in Col 4)  
 - Grand Total, which is the sum of the total amount for all the Enq. Nos. tabulated in Col 8

Agree to sustain the existing IBR Certification for the firm/Obtain IBR Certification before the award of contract and sustain the same during the contract period.	
Agree to maintain the set of equipments considered essential for carrying out the specimen preparation work in good working condition during the tenure of contract.	
Agree to procure and install the balance essential equipments for carrying out the specimen preparation work ( as identified during the BHEL Committee visits) well before the award of contract	
Agree that we have gone through the STAC and Scope of Enquiry and agree to adibe by all the conditions stated therein, in the event of being awarded the contract.	

If you have AGREED with all the above four clauses, you may go ahead filling up the Price Bid. If you DISAGREE with any of the above, the price bid submitted by you is not deemed valid.

1	2	3	4	5	6	7	8
Enq. No.	Material Description	Sketch No	Estimated Quantity	No of Specimen	Price/Specimen in Rs.	Amount/Test Coupon in Rs.	Total Amount in Rs.
1	Welder IQ Test plate 16-20 Tk x 300 x 300 mm	Q:PL:CP:001	1000				
	Tr.Tensile	Q:PL:SP:001		2			
	Tr.Bend	Q:PL:SP:002		4			
	Macro	Q:PL:SP:003		1			
	Micro	Q:PL:SP:004		1			
2	Welder RQ Test plate	Q:PL:CP:002	750				
	Tr.Tensile	Q:PL:SP:001		1			
	Tr.Bend	Q:PL:SP:002		2			
	Macro	Q:PL:SP:003		2			
3	Welded Pipes & Tubes IQ & RQ Ø44.5-127 mm & Tk 5.0 - 12.5 mm	Q:PL:CP:003	2500				
	Bend	Q:PL:SP:006		4			
	Macro	Q:PL:SP:005		2			
4	Welder Qualification Pipes IQ & RQ upto Ø200mm & Tk upto 25mm	Q:PL:CP:003					
	Tr.Tensile	Q:PL:SP:008		2			

	Tr. Bend	Q:PL:SP:011	3000	4			
	Macro	Q:PL:SP:003		1			
	Micro/Hardness	Q:PL:SP:004		2			
5	Branch Welds IQ & RQ Main Pipe: Ø406.4 x 22mm Branch Pipe: Ø88.9 x 6.2mm	Q:PL:CP:004	3000				
	Macro	Q:PL:SP:007		4			
6	Procedure Qualification of tubular joints upto Ø63.5 mm	As per relevant MSTP	1000				
	Tr.Tensile	Q:PL:SP:008		1			
	Tr. Bend	Q:PL:SP:011		2			
	Macro	Q:PL:SP:003		1			
	Micro/Hardness	Q:PL:SP:004		1			
7	Production Test Coupon(Welded) plate 30 mm Tk x 1000 x 300 mm	Q:PL:CP:005,006 & 007	100				
	Tr.Tensile	Q:PL:SP:008		1			
	R. Tensile	Q:PL:SP:009		1			
	Bend	Q:PL:SP:011		2			
	Macro	Q:PL:SP:003		1			
	Micro	Q:PL:SP:004		1			
	Impact	Q:PL:SP:010	3				
8	Production Test Coupon (PTC) Plate 40-60 mm Tk	Q:PL:CP:005,006 & 008	50				
	Tr.Tensile	Q:PL:SP:008		2			
	R. Tensile	Q:PL:SP:009		1			
	Bend	Q:PL:SP:011		2			
	Macro	Q:PL:SP:003		1			
	Micro	Q:PL:SP:004		1			
	Impact	Q:PL:SP:010	3				
9	PTC Plate 61-90mm Tk x 1000 x 300 mm	Q:PL:CP:005,006 & 009	100				
	Tr.Tensile	Q:PL:SP:008		3			
	R. Tensile	Q:PL:SP:009		2			
	Bend	Q:PL:SP:011		2			
	Macro	Q:PL:SP:003		1			
	Micro	Q:PL:SP:004		1			
	Impact	Q:PL:SP:010	3				
10	PTC Plate 91-120 mm Tk x 1000 x 300 mm	Q:PL:CP:005,006 & 010					
	Tr.Tensile	Q:PL:SP:008	4				
	R. Tensile	Q:PL:SP:009	2				

	Bend	Q:PL:SP:011	150	2			
	Macro	Q:PL:SP:003		1			
	Micro	Q:PL:SP:004		1			
	Impact	Q:PL:SP:010		3			
11	PTC Plate 121-150 mm Tk x 1000 x 300 mm	Q:PL:CP:005,006 & 011	200				
	Tr.Tensile	Q:PL:SP:008		5			
	R. Tensile	Q:PL:SP:009		2			
	Bend	Q:PL:SP:011		2			
	Macro	Q:PL:SP:003		1			
	Micro	Q:PL:SP:004		1			
	Impact	Q:PL:SP:010		3			
12	PTC Plate 151-200 mm Tk x 1000 x 300 mm	Q:PL:CP:005,006,012 & 013	100				
	Tr.Tensile	Q:PL:SP:008		6			
	R. Tensile	Q:PL:SP:009		3			
	Bend	Q:PL:SP:011		2			
	Macro	Q:PL:SP:003		1			
	Micro	Q:PL:SP:004		1			
	Impact	Q:PL:SP:010		3			
13	Raw Material Plates 13-80 mm Tk x 300 x300 mm	Q:PL:CP:014 & 015	1000				
	Spectral + Drillings	Q:PL:SP:016		1			
	R. Tensile/Shoulder Tensile	Q:PL:SP:013/015/017		1			
	Hardness/Micro	Q:PL:SP:016		1			
	Bend	Q:PL:SP:014		1			
	Threaded Tensile	Q:PL:SP:012		1			
14	Raw Material Plates (RTC) upto 100 mm Tk x 300 x300 mm	As per relevant MSTP	50				
	Spectral + Drillings	Q:PL:SP:016		1			
	R. Tensile/Shoulder Tensile	Q:PL:SP:013/015/017		4			
	Hardness/Micro	Q:PL:SP:016		1			
	Bend	Q:PL:SP:014		1			
	Threaded Tensile	Q:PL:SP:012		1			
	Impact	Q:PL:SP:010		24			
	Pellini Drop Weight specimen	Blanks & Notch cutting as per MSTP	2				
15	Raw Materials Round Ø30-100 mm	Q:PL:CP:016	250				
	Spectral + Drillings	Q:PL:SP:016		1			
	R. Tensile	Q:PL:SP:013/015		1			

	Hardness/Micro	Q:PL:SP:016		1			
16	Raw Materials Round Ø30-100 mm with Impact	Q:PL:CP:016	300				
	Spectral + Drillings	Q:PL:SP:016		1			
	R. Tensile	Q:PL:SP:013/015		1			
	Hardness/Micro	Q:PL:SP:016		1			
	Impact	Q:PL:SP:010		3			
17	Raw Material Tubes		500				
	Spectral +Drillings	Q:PL:SP:016		1			
	Shoulder Tensile	Q:PL:SP:017		1			
	Flattening	Q:PL:SP:019		1			
	Flaring	Q:PL:SP:018		1			
	Hardness/Micro	Q:PL:SP:016		1			
18	Raw Material Pipes		750				
	Spectra+Drillings	Q:PL:SP:016		1			
	Tensile	Q:PL:SP:013/015/017		1			
	Flattening	Q:PL:SP:019		1			
	Hardness	Q:PL:SP:016		1			
	Micro	Q:PL:SP:016		1			
	Threaded Tensile	Q:PL:SP:012		1			
19	Fittings		500				
	Spectral +Drillings	Q:PL:SP:016		1			
	R. Tensile	Q:PL:SP:013/015		1			
	Hardness/Micro	Q:PL:SP:016		1			
20	Forgings		500				
	Spectral +Drillings	Q:PL:SP:016		1			
	Tensile	Q:PL:SP:013/015		1			
	Hardness	Q:PL:SP:016		1			
21	Bar Stocks without Impact		250				
	Spectral + Drillings	Q:PL:SP:016		1			
	Tensile	Q:PL:SP:013/015		1			
	Hardness/Micro	Q:PL:SP:016		1			
22	Bar Stocks with Impact		700				
	Spectral + Drillings	Q:PL:SP:016		1			
	Tensile	Q:PL:SP:013/015		1			
	Hardness/Micro	Q:PL:SP:016		1			

	Impact	Q:PL:SP:010		3			
23	Stud, Bolt, Nut & other fasteners		3000				
	Spectral + Drillings	Q:PL:SP:016		1			
	Tensile	Q:PL:SP:013/015		1			
	Hardness/Micro	Q:PL:SP:016		1			
	Proof load	As per MSTP		1			
24	Non-ferrous items		50				
	Spectral + Drillings	Q:PL:SP:016		1			
	Tensile	Q:PL:SP:013/015		1			
	Hardness/Micro	Q:PL:SP:016		1			
25	SS PIPE PQT / Performance qlfn. upto 50 mm		130				
	All weld tensile	Q:PL:SP:009		6			
	Tr.Tensile	Q:PL:SP:008		6			
	Tr.Bend	Q:PL:SP:011		8			
	Side Bend	Q:PL:SP:020		4			
	Drillings+Spectral	Q:PL:SP:016		3			
	Macro	Q:PL:SP:003		6			
	Micro	Q:PL:SP:016		6			
	IGCT	Q:PL:SP:022		4			
	Delta Ferrite	Q:PL:SP:021		3			
	Impact	Q:PL:SP:010	18				
26	SS Consumable / Welder Qlfn. Test Coupon 22- 40 Tk x 1000 x 300 mm	As per relevant MSTP	50				
	All weld Tensile	Q:PL:SP:009		6			
	Tr.Tensile	Q:PL:SP:008		3			
	Tr.Bend	Q:PL:SP:011		4			
	Side Bend	Q:PL:SP:020		4			
	Impact	Q:PL:SP:010		9			
	IGCT	Q:PL:SP:022		4			
	Drillings + spectral	Q:PL:SP:016		1			
	Delta ferrite	Q:PL:SP:021		3			
	Micro	Q:PL:SP:003		2			
	Macro	Q:PL:SP:004	2				
27	CS Consumable Qlfn. Test Coupon 22-40 x 1000 x 300 mm	As per relevant MSTP					
	All weld Tensile	Q:PL:SP:009		6			
	Tr.Tensile	Q:PL:SP:008		3			
	Tr.Bend	Q:PL:SP:011	4				

	Side Bend	Q:PL:SP:020	25	4		
	Impact	Q:PL:SP:010		30		
	Drillings + spectral	Q:PL:SP:016		1		
	Macro	Q:PL:SP:003		2		
	Micro	Q:PL:SP:004		2		
28	Cladded Plate / PQT 40/100 mm thick plates	As per relevant MSTP	75			
	All weld Tensile	Q:PL:SP:009		6		
	Tr.Bend	Q:PL:SP:011		4		
	Side Bend	Q:PL:SP:020		4		
	Impact	Q:PL:SP:010		12		
	Drillings + spectral	Q:PL:SP:016		10		
	Macro	Q:PL:SP:003		2		
	Micro	Q:PL:SP:004		2		
	IGCT	Q:PL:SP:022		4		
	Test opening	As per relevant MSTP		1		
	Hot Crack Test	As per relevant MSTP		1		
	Delta Ferrite	Q:PL:SP:021		3		
29	PQT/FTC SS Plate 15-100 mm Tk	As per relevant MSTP	50			
	All weld Tensile	Q:PL:SP:009		6		
	Tr.Tensile	Q:PL:SP:008		3		
	Tr.Bend	Q:PL:SP:011		8		
	Side Bend	Q:PL:SP:020		4		
	Impact	Q:PL:SP:010		18		
	Drillings + spectral	Q:PL:SP:016		3		
	Macro	Q:PL:SP:003		6		
	Micro	Q:PL:SP:004		6		
	IGCT	Q:PL:SP:022		4		
	Delta Ferrite	Q:PL:SP:021		3		
30	PQT/FTC CS/AS Plate 15-100 mm Tk	As per relevant MSTP	125			
	All weld Tensile	Q:PL:SP:009		6		
	Tr.Tensile	Q:PL:SP:008		6		
	Tr.Bend	Q:PL:SP:011		8		
	Side Bend	Q:PL:SP:020		4		
	Impact	Q:PL:SP:010		90		
	Drillings+Spectral	Q:PL:SP:016		9		
	Macro	Q:PL:SP:003		6		
	Micro	Q:PL:SP:004		6		
	Pellini Drop Weight specimen	Blanks & Notch cutting as per MSTP	3			

31	Procedure/Consumable qualification test coupon 15-40 mm						
	Tr.Tensile	Q:PL:SP:008	100	2			
	Tr.Bend/Side Bend	Q:PL:SP:011/020		4			
	Harness/Macro	Q:PL:SP:016		1			
	Drillings+Spectral	Q:PL:SP:016		1			
32	Procedure qualification test coupon Fillet Joint/Panel Tube	As per ASME Sec IX					
	Macro	Q:PL:SP:007	100	1			
	Fracture	Q:PL:SP:007		1			
33	Failure Investigation Tubes & Pipes	As per relevant markings on the tubes					
	Drillings+Spectral	Q:PL:SP:016	3000	2			
	Flattening	Q:PL:SP:019		1			
	Hardness/Micro	Q:PL:SP:016		3			
	Ring Micro	Q:PL:SP:023		1			
34	Titanium plate upto 15mm	As per relevant MSTP					
	All weld tensile	Q:PL:SP:022	40	1			
	HFT	Q:PL:SP:026		2			
	Hot Tensile/Threaded	Q:PL:SP:012		1			
	Tr. Tensile	Q:PL:SP:008		1			
	Tr. Bend	Q:PL:SP:011		2			
	Side Bend	Q:PL:SP:020		2			
	Impact	Q:PL:SP:010		6			
	Drillings+Spectral	Q:PL:SP:016		1			
	SCC	Q:PL:SP:022		2			
	Macro	Q:PL:SP:003		2			
	Micro	Q:PL:SP:004		2			
35	Titanium Pipe and Plate (PQT/Welder qfn.)	As per relevant MSTP					
	Tr. Tensile	Q:PL:SP:008	60	2			
	All Weld Tensile	Q:PL:SP:022		2			
	High Temperature Tensile	Q:PL:SP:012 or 026		2			
	Tr. Bend	Q:PL:SP:011		2			
	Side Bend	Q:PL:SP:020		2			
	Impact	Q:PL:SP:010		6			
	Drillings+Spectral	Q:PL:SP:016		1			
	SCC	Q:PL:SP:022		2			
	Macro	Q:PL:SP:003		2			
	Micro	Q:PL:SP:004		2			

36	Titanium Tubes	As per relevant MSTP	50			
	Full tube tensile			2		
	Longitudinal Macro	Q:PL:SP:003		2		
	Ring Macro	Q:PL:SP:023		2		
	Flattening	Q:PL:SP:019		2		
	SCC	Q:PL:SP:022		2		
	Macro	Q:PL:SP:003		2		
37	Titanium Consumable Qualification&PQT	As per relevant MSTP	25			
	All Weld Tensile/HFT	Q:PL:SP:022		2		
	High Temp.Tensile/HFT	Q:PL:SP:012 or 026		2		
	Tr. Bend	Q:PL:SP:011		4		
	Side Bend	Q:PL:SP:020		2		
	Impact	Q:PL:SP:010		6		
	Drillings+Spectral	Q:PL:SP:016		1		
	SCC	Q:PL:SP:022		2		
	Macro	Q:PL:SP:003		4		
	Micro	Q:PL:SP:004		2		
38	Titanium(Plate,Pipe) Fillet Joint	As per relevant MSTP	40			
	Macro	Q:PL:SP:003		4		
	Micro	Q:PL:SP:004		2		
39	Titanium tube end welds	As per relevant MSTP	750			
	Macro (MLP)	Q:PL:SP:003		2		
	Macro Tr	Q:PL:SP:003		2		
40	Inconel Tube End Welds	As per relevant MSTP	400			
	Macro (MLP)	Q:PL:SP:003		2		
	Macro Tr	Q:PL:SP:003		2		
41	Miscellaneous cut piece(upto 100mm)	As per relevant drawings				
	Round Tensile		1100	1		
	Impact		200	1		
	Macro		100	1		
	Micro		100	1		
	Bend		300	1		
	CCT specimens	As per CCT drawing	200	1		
	Round specimen without threads		900	1		
	Square specimen		500	1		

	Notch preparation in Drop weight specimen		400	1			
	CTOD Specimen	Q:PL:SP:CTOD	100	1			
	K <sub>1</sub> C	Q:PL:SP:K1C	100	1			
	JC <sub>1</sub>	Q:PL:SP:JC1	100	1			
42	Edge preparation of Plates / pipes /tubes	As per relevant drawings					
	Pipes 101-250 mm dia		3000	1			
	Plates upto 25 mm tk		4000	1			
			Total				



**BHARAT HEAVY ELECTRICALS LIMITED**  
**TIRUCHIRAPPALLI-620 014**  
**PLANT LABORATORY**

**STANDARD TERMS & CONDITIONS (STAC)**  
**FOR ENQUIRY AND PURCHASE ORDER**

STAC NO	TERMS & CONDITIONS
1.0	<b>EARNEST MONEY DEPOSIT(EMD):</b> THE SUB CONTRACTOR HAS TO MAKE AN EMD OF Rs.2,00,000/- BY WAY OF A DEMAND DRAFT DRAWN IN FAVOUR OF BHEL, TIRUCHIRAPPALLI , WHICH HAS TO BE HANDED OVER TO ADDL. GENERAL MANAGER, PLANT LABORATORY,BHEL,TIRUCHIRAPPALLI. THIS WILL BE ADJUSTED AGAINST THE SECURITY DEPOSIT / BANK GUARANTEE, ONCE THE CONTRACT HAS BEEN AWARDED TO THE CONTRACTOR.
1.1	<b>BANK GUARANTEE:</b> The Subcontractor shall have to execute a Bank Guarantee to the value as required by BHEL for satisfactory performance of the order and also for the safe custody of the raw materials. The Guarantee shall be executed on a non-judicial stamp paper of the value as given below:  BANK GUARANTEE DEPOSIT: I) UPTO RS 10 LAKHS 10% II) ABOVE RS 10 LAKHS UPTO RS 50 LAKHS: 7.5% OF THE AMOUNT EXCEEDING RS 10 LAKHS UPTO 50 LAKHS. III) ABOVE RS 50 LAKHS: RS 4 LAKHS PLUS 5% OF THE AMOUNT EXCEEDING RS 50 LAKHS. THE SAID AMOUNT SHALL BE SUBMITTED IN THE PRESCRIBED FORMAT PRIOR TO THE RELEASE OF PURCHASE ORDER FROM THE PLANT LAB.
2.0	<b>ACCEPTANCE OF THE PURCHASE ORDER:</b> In the absence of any objection received from the Subcontractor within 15 days after the receipt of our Purchase Order, it will be assumed that the Order is fully accepted by the Subcontractor.
3.0	<b>ISSUE OF RAW MATERIALS FIRM TO COLLECT (FTC):</b> 3.1 The raw materials, to be supplied for manufacturing the components will be collected from BHEL at the subcontractor's cost. 3.2 While collecting materials from BHEL, Subcontractors shall check-up for the correct size, specification and quantity of the materials as per the entry in the Non returnable Gate Pass/Drawing requirement. 3.3 If any shortage, deviations and damage in the raw materials is noticed, the same shall be communicated to Plant Lab immediately. 3.4 If the issued material is not sufficient to prepare specimens, the same is to be immediately reported to Plant Laboratory with details for further issue of materials. 3.5 Attestation procedures are to be followed wherever required. The subcontractor should ensure safety, proper storage & preservation of raw materials/goods issued by BHEL for easy traceability.
4.0	<b>GAUGES AND MEASURING INSTRUMENTS:</b> 4.1 All standard Gauges & Measuring Instruments are to be possessed by the subcontractor, which are duly calibrated by approved agency. Periodic calibration should be carried out as per the recommendation of BHEL. 4.2 Before using Gauges/Measuring Instruments, for the manufacture/inspection of the components, it should be ensured that the calibration is not over due.
5.0	<b>PROVISION OF ADEQUATE SAFETY MEASURES:</b> The subcontractor shall maintain and ensure necessary safety measures with respect to plant, machinery and

personnel at his works, as required for during manufacture, visits of BHEL personnel and inspection of the job. If any equipment is found not complying with proper safety requirements/conditions, then BHEL may withhold visit/inspection or instruct stoppage of work till such time the desired safety requirements are met.

#### **6.0 MANUFACTURE OF COMPONENTS:**

6.1 The subcontractor shall be able to prepare and supply all types of specimens specified in the tender and he should ensure the availability of all the Drawing/Quality documents provided by BHEL, Plant Lab.

6.2 The specimens mentioned in our Enquiry and Purchase Order shall be strictly prepared as per the scope and as per our Drawing/Quality documents. Any deviation observed from the Drawing/Quality documents may attract penalty.

#### **7.0 PROGRESS REPORT**

7.1 The subcontractor's performance will be evaluated based on the performance against the delivery commitments and also with respect to response of the subcontractor and quality of the components.

7.2 BHEL reserves the right to cancel the contract at any point of time during the contract period if periodic deviations or inability of the contractor in preparation and supply of specimens as per the applicable Drawing/Quality documents as specified in the tender.

#### **8.0 INSPECTION**

8.1 Inspection of the specimens may be carried out by BHEL, Plat Lab and/or authorized Inspection agencies and the recorded results shall be maintained in a register at subcontractor's work.

#### **9.0 MARKING**

Proper Identification number shall be punched on the specimens and on the balance material. If required, TPI stamping shall be preserved on all specimens including balance material.

#### **10.0 TERMS OF DELIVERY FOR FINISHED TEST SPECIMENS**

10.1 Final test specimens shall be delivered at Plant Laboratory along with the Dimensional Report of the prepared specimens and Delivery Chalan at subcontractor's cost.

10.2 The delivery challan should be prepared for each MTL/INV/NS nos. separately.

10.3 The consignment should accompany 3 copies of IR and 6 copies of Delivery Challans giving reference to MTL/INV/NS Nos. and number of items dispatched. Plant laboratory will give acknowledgement on 3 copies of Delivery challan for having received the items and for billing purpose.

10.4 Without the above documents, test specimens will not be accepted by BHEL and hence the above points shall be carefully noted to avoid delays in acceptance of any item and the subsequent payment.

#### **11.0 PAYMENT**

11.1 Payment will be made for 100% for the supplies made against your invoices in triplicate and 2 copies of Inspection Report (IR) supported by:

2 copies of Delivery Challans acknowledged by Executives of Plant Lab.

#### **11.2 OTHER PAYMENTS AS GIVEN BELOW WILL BE PAID EXTRA IF APPLICABLE:**

-IBR Fees

- Any other Third Party Inspection charges if required will be borne by BHEL.

11.3 The invoice shall be addressed to AGM/Plant Laboratory.

#### **12.0 ACCOUNTAL OF RAW MATERIALS:**

Balance material will be accounted on completion of the order. Excess/balance material will have to be returned to Plant Laboratory by subcontractor immediately through DC.

**13.0 LIQUIDATED DAMAGES:**

- 13.1 Finished specimens against a work order delivered beyond the delivery time stipulated in the SCOPE OF ENQUIRY, are liable for liquidated damages @ Rs 5000/= or the total value of the work order raised whichever is maximum.
- 13.2 If the Vendor is unable to keep the delivery schedule of the time, extension of time on specific request may be granted by BHEL to the extent considered necessary.

**14.0 RISK PURCHASE**

BHEL, at its option, will be entitled to terminate the contract and to offload elsewhere at the risk and cost of the subcontractor either whole of the test materials or any part which the subcontractor has failed to deliver or despatch within the time stipulated by BHEL. No payment shall be made for the work done by the subcontractor.

**15.0 SUBLETTING**

- 15.1 The subcontractor shall not sublet or assign the contract or any part thereof without the prior permission of BHEL.
- 15.2 In case of specimens like CTOD, K<sub>1</sub>C & J<sub>C1</sub> the subcontractor can outsource the machining activities after obtaining prior permission from BHEL, Plant Lab. The subcontractor should not reject the offered load for these specimens citing invalid reasons, doing so may attract penalty as stated in Clause 13.0.

**16.0 GENERAL**

- 16.1 BHEL reserves right to increase or decrease the tendered quantity and split the tendered quantity among more than one tenderer and place orders accordingly in any proportion, based on commitment, requirement and subcontractors' capability in terms of delivery and quality.
- 16.2 The drawings issued by BHEL should be returned along with your offer.
- 16.3 Any other work done over & above the requirements of drawings shall have the prior written approval of the competent authority of BHEL.
- 16.4 Adequate facilities like cutting machines, milling machine, notch broaching machine, lathe, surface grinding machine, handling facilities and measuring instruments must be available with the subcontractor for the specimen preparation activity. All the above basic requirements must be under working condition along with the machine consumables and the same may be made available for verification by BHEL officials or their authorized agents.
- 16.5 BHEL reserves right to divert/withdraw partly or fully its materials from subcontractor's works at any time.
- 16.6 The subcontractor should keep the environment of his premises neat, clean and safe.
- 16.7 Any change in the constitution of the subcontractor's unit will have to be made after getting specific approval from Plant Laboratory, BHEL, Tiruchirappalli. Any deviation, if found later, will be dealt with as deemed fit including cancellation of registration.
- 16.8 All statutory obligations such as ESI, PF, Labour Act, Factory's Act etc will have to be taken care of by the subcontractor. BHEL will have no liability on them. Notwithstanding the above, if any demand notice is served by the concerned Statutory Authorities for recovery of any of their dues on BHEL, the same would be paid without notice to the subcontractor. Such act of repeated default is liable for suspension/stoppage of further business till such time the default/violations get vacated.
- 16.9 All the documents of BHEL made available to the subcontractor should be kept in strict confidence and under no circumstance be made available to others or allow others to make use for any other commercial purpose whatsoever. Such document should be returned to BHEL, Tiruchirappalli. This secrecy clause is binding on the employees of the subcontractor also. Any contravention will be viewed seriously.
- 16.10 Unless prior permission of BHEL has been obtained, retired or resigned employees of BHEL may not be considered for enlistment as contractors nor allowed to work as employees of subcontractor for a period of two years from their retirement or resignation from service. If, subsequently, either the subcontractor or any of the employees is found at any time to be such a person who has not obtained the permission of BHEL as aforesaid, the person's name is liable to be removed from the list of approved subcontractors.

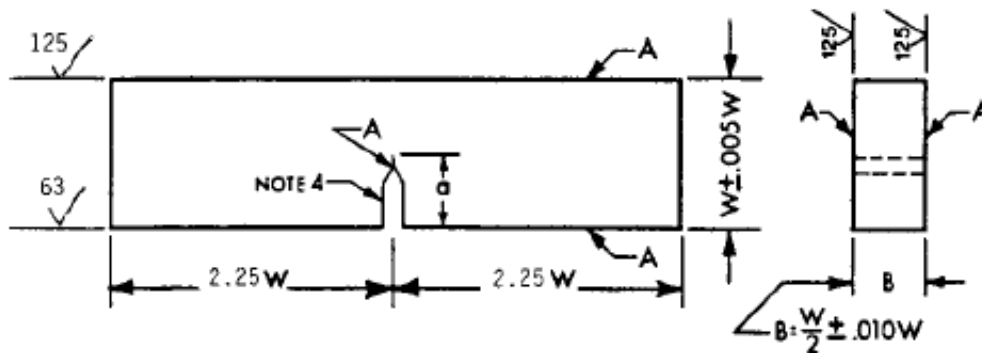

NOTE 1—A surfaces shall be perpendicular and parallel as applicable within  $0.001 W$  TIR.

NOTE 2—Crack starter notch shall be perpendicular to specimen surfaces to within  $\pm 2^\circ$ .

NOTE 3—Integral or attachable knife edges for clip gage attachment may be used (see Fig. 4).

NOTE 4—For starter notch and fatigue crack configurations see Fig. 8.

**FIG. 6 Proportional Dimensions and Tolerances for Rectangular Section SE(B) Specimens**

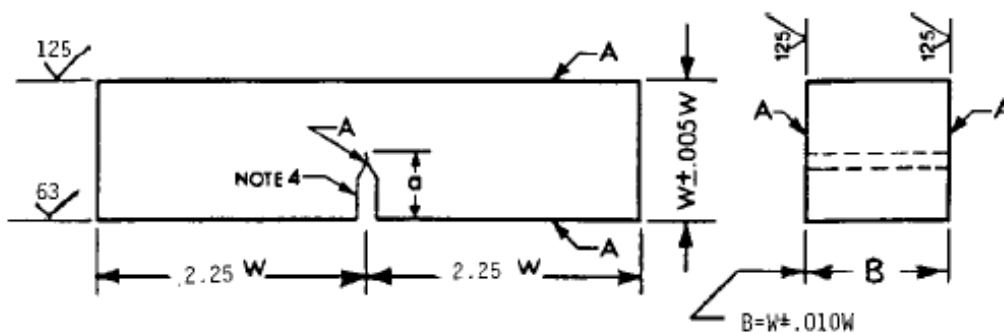

NOTE 1—A surfaces shall be perpendicular and parallel as applicable within  $0.001 W$  TIR.

NOTE 2—Crack starter notch shall be perpendicular to specimen surfaces to within  $\pm 2^\circ$ .

NOTE 3—Integral or attachable knife edges for clip gage attachment may be used (see Fig. 4).

NOTE 4—For starter notch and fatigue crack configurations see Fig. 8.

**FIG. 7 Proportional Dimensions and Tolerances for Square Section SE(B) Specimens**

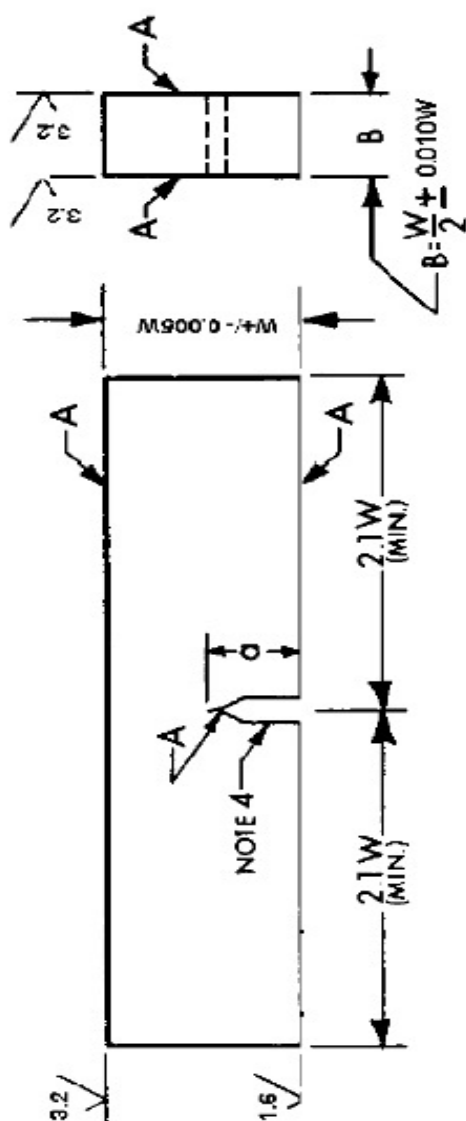

NOTE 1—Surface finishes in  $\mu\text{m}$ .

NOTE 2—A surfaces shall be perpendicular and parallel as applicable within 0.001 W TIR.

NOTE 3—Crack starter notch shall be perpendicular to specimen surfaces within  $2^\circ$ .

NOTE 4—Integral or attachable knife edges for clip gage attachment may be used (see Figs. 3 and 4)

NOTE 5—For starter notch and fatigue crack configuration see Fig. 5.

NOTE 6—1.6  $\mu\text{m} = 63 \mu\text{m}$ , 3.2  $\mu\text{m} = 125 \mu\text{m}$ .

**FIG. A3.1 Bend SE(B) Specimen—Standard Proportions and Tolerances**

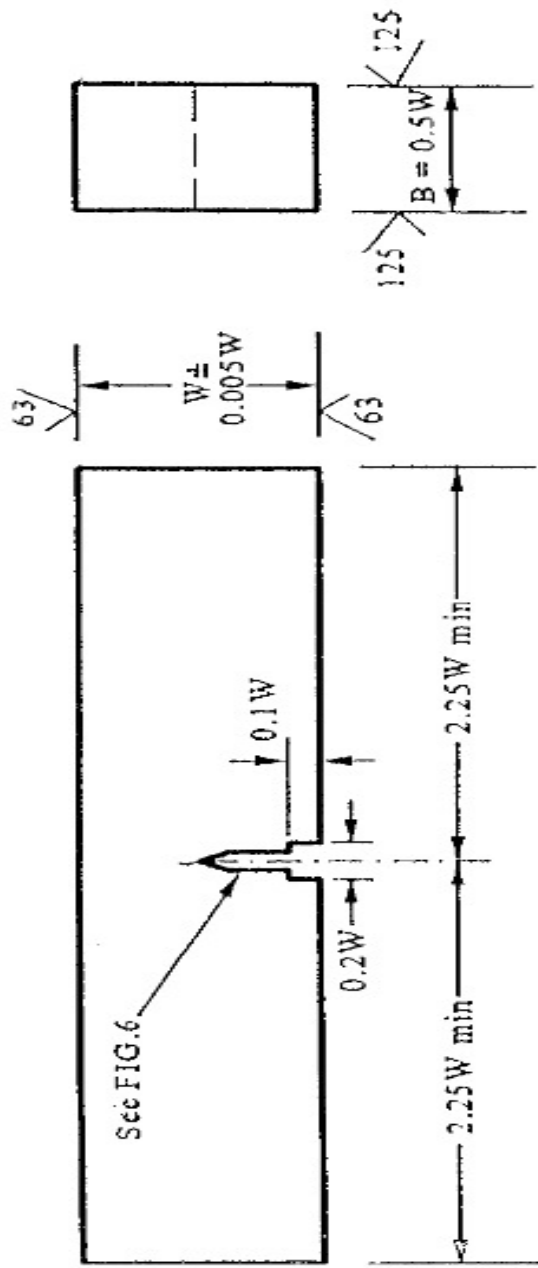

NOTE 1—The two side planes and the two edge planes shall be parallel and perpendicular as applicable to within  $0.5^\circ$ .

NOTE 2—The machined notch shall be perpendicular to specimen length and thickness to within  $\pm 2^\circ$ .

**FIG. A.1.1 Recommended Single Edge Bend [SE(B)] Specimen**



## WELDERS' REQUALIFICATION TEST PLATE

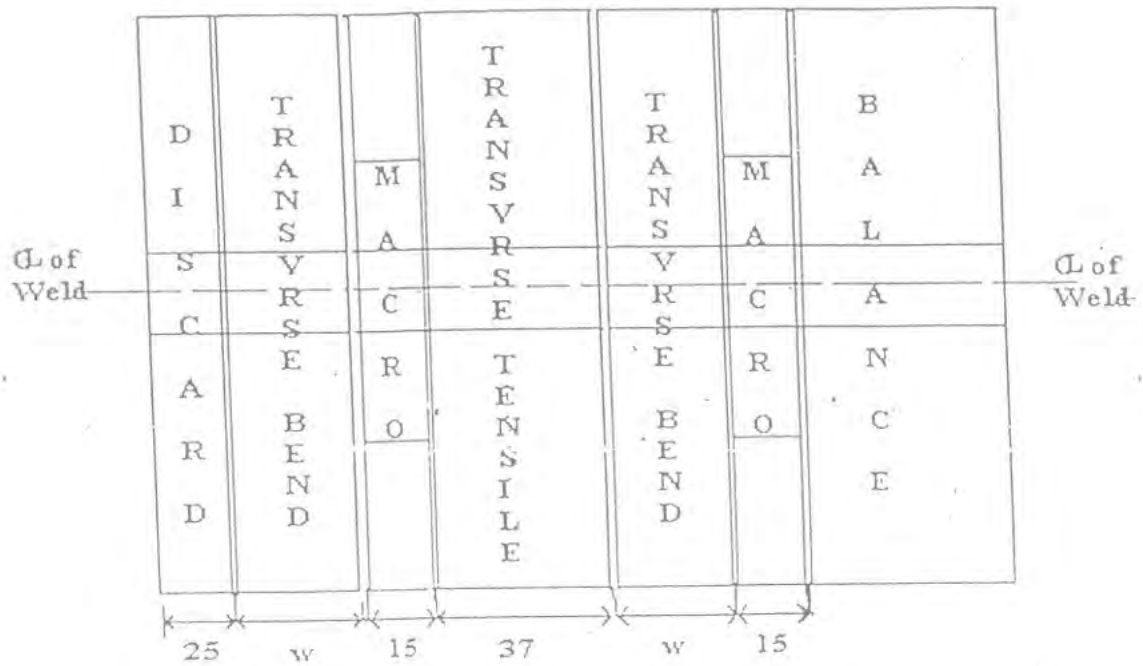

## ORDER OF REMOVAL OF TEST SPECIMENS FROM PLATE

Plate Thickness mm.	'W' Width of Bend specimens mm.
16	25
20	30

Specimen type	No of specimens
Tr. Tensile	1
Tr. Bend	2
Macro	2

## NOTE:

1. If cutting is done exactly perpendicular to weld axis and no taper is present across thickness, no milling is required for Tensile and bend specimen slices.
2. No thermal cutting is allowed.
3. Preserve balance material with proper Identification.
4. Boiler Inspectorate seal to be transferred on specimens.

*R. Vaideeswaran*  
**Dr. R. VAIDEESWARAN,**  
 Manager  
 Plant Lab / Quality  
 BHEL., Trichy- 620 014

## WELDERS' QUALIFICATION - PIPE AND TUBE - IQ AND RQ

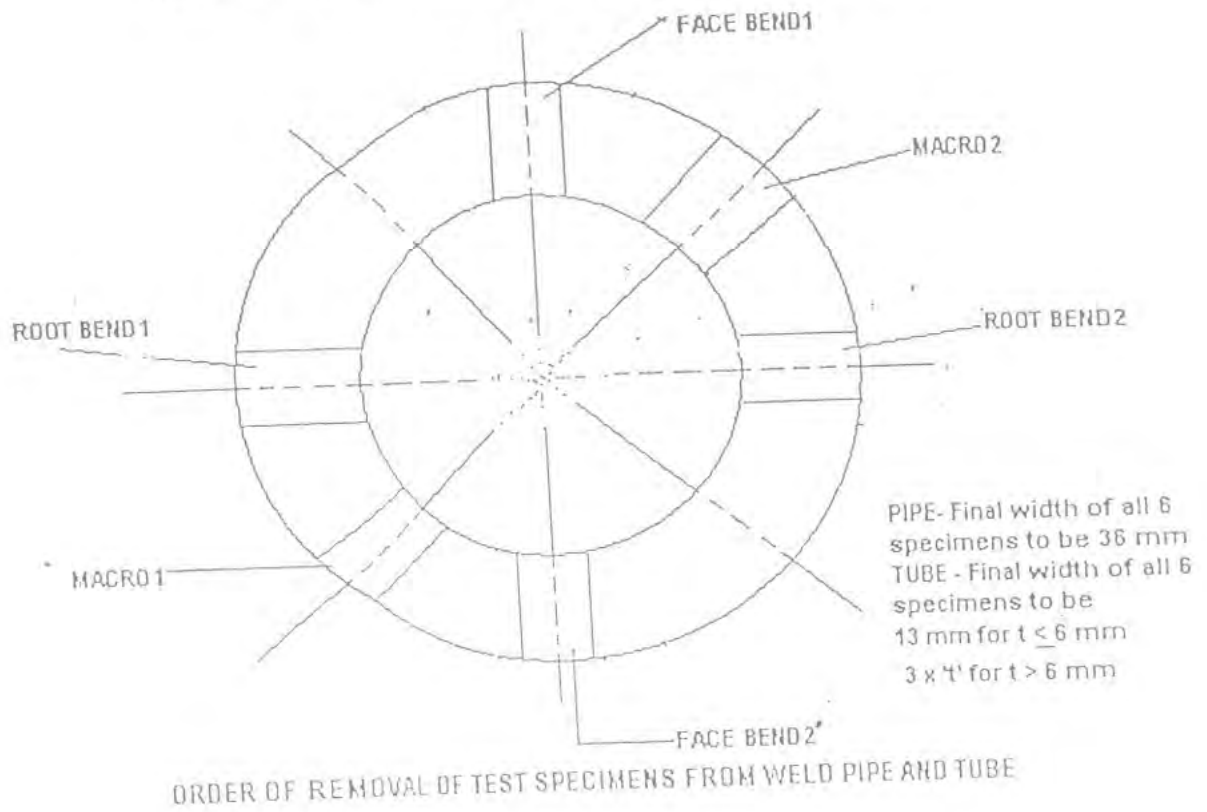

Specimen type	No of specimens
Tr. Bend	4
Macro	2

## NOTE:

1. No thermal cutting is allowed.
2. Preserve balance material with proper Identification.
3. Boiler Inspectorate seal to be transferred on specimens.

*R. Vaideeswaran*

**Dr. R. VAIDEESWARAN,**  
Manager  
Plant Lab / Quality  
BHEL., Trichy- 620 014

**BRANCH WELD**

Cutting plan  
4 macro specimens

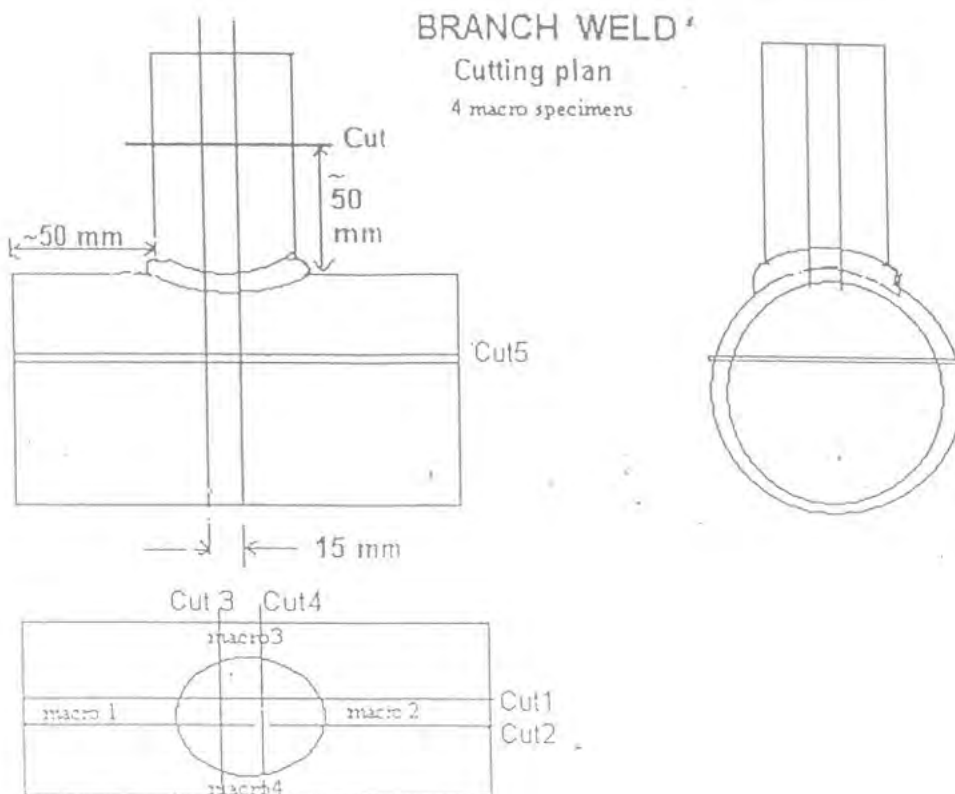

**NOTE:**

1. No thermal cutting is allowed.
2. Preserve balance material with proper Identification.
3. Boiler Inspectorate seal to be transferred on specimens.
4. If cutting is done exactly parallel, milling & Grinding on one side is sufficient

*R. Vaideeswaran*  
**Dr. R. VAIDESWARAN,**  
 Manager  
 Plant Lab / Quality  
 BHEL., Trichy- 620 014

Q: PL: CP 005

# IBR PRODUCTION TEST COUPON - CUTTING PLAN

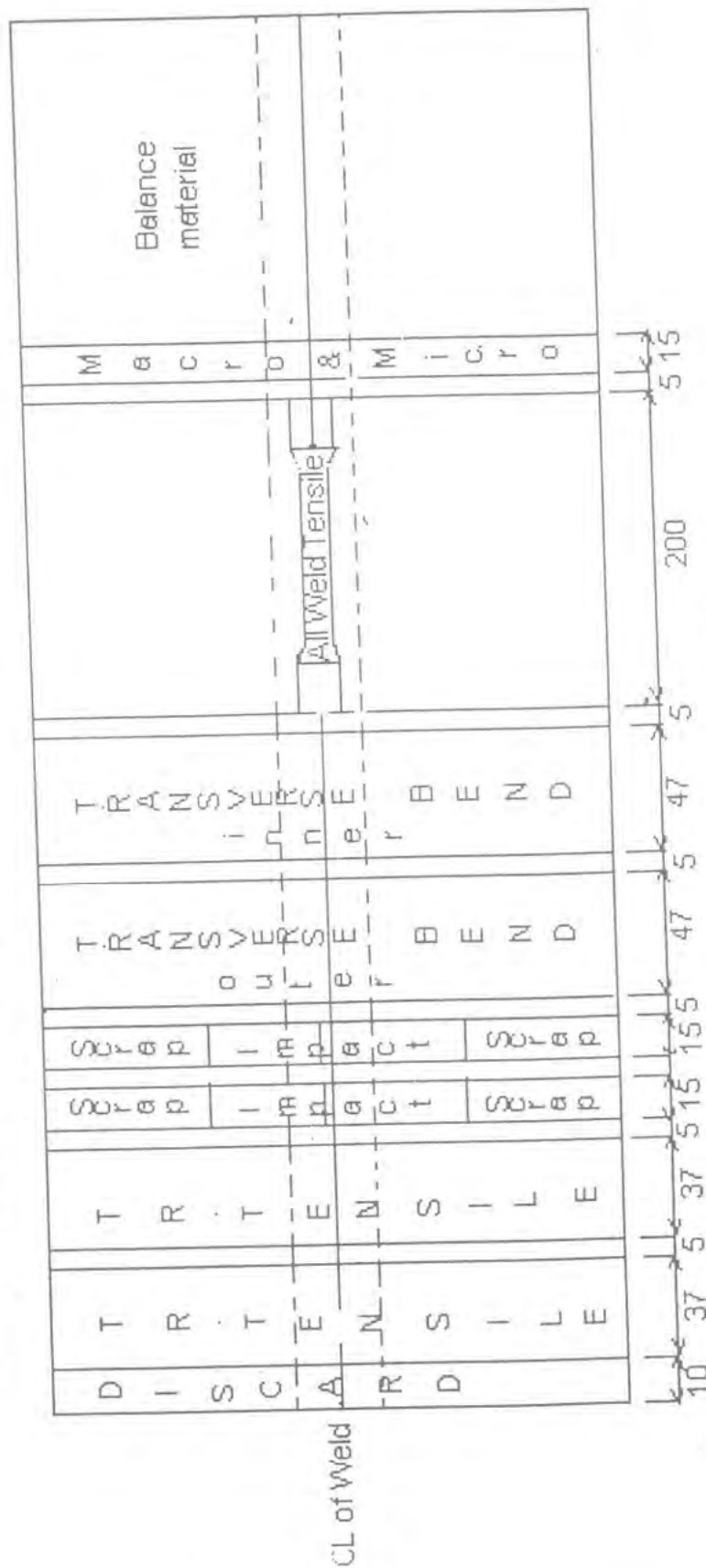

- NOTE:**
1. If cutting is done exactly perpendicular to weld axis and no taper is present across thickness, no milling is required for Tensile and bend specimen slices.
  2. No thermal (gas, plasma etc) allowed.
  3. Preserve balance material with proper identification and Inspector's seal.
  4. Boiler Inspector's seal shall be preserved on the specimen.

*(Signature)*  
**Dr. R. VAIDEESWARAN,**  
 Manager  
 Plant Lab / Quality

Q: PL: CP: 006

LOCATION OF IMPACT SPECIMENS IN THE DRUM/PFP/HEADER

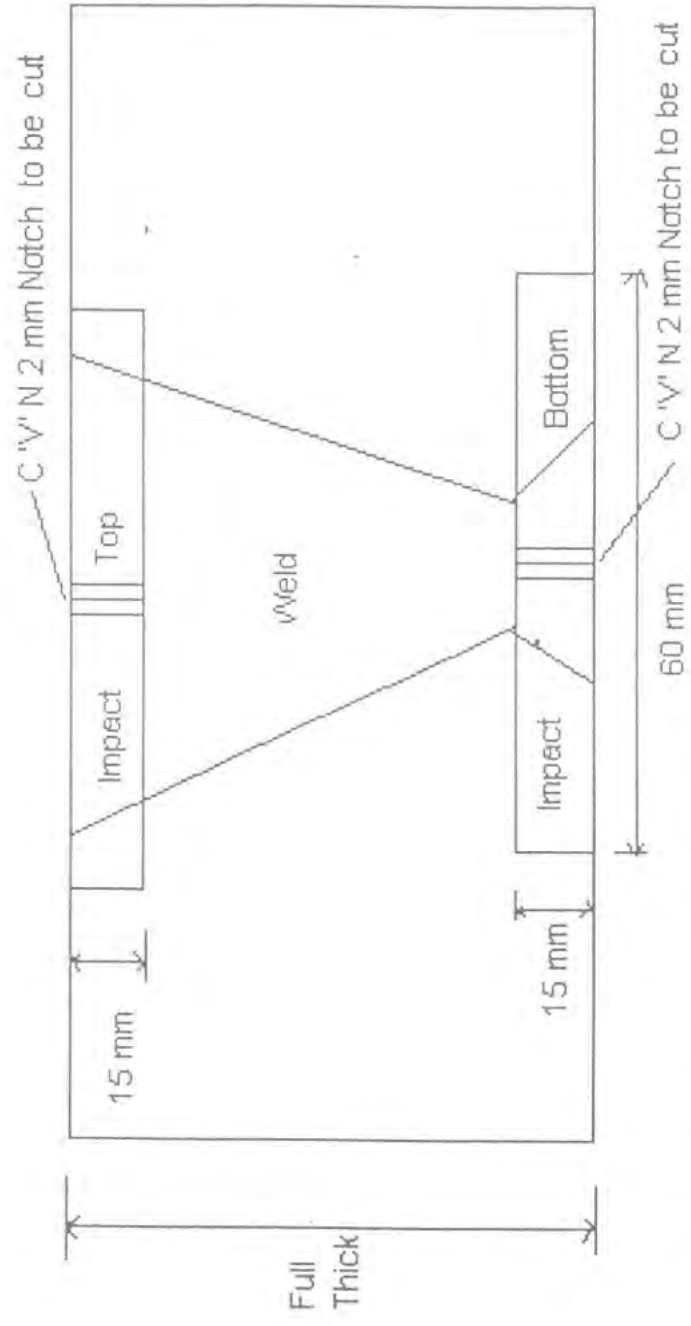

Note: Hacksaw cutting only is permitted.  
 Thermal (gas, plasma etc) are not allowed.  
 Proper identification shall be transferred one end of the piece.  
 Inspector's seal shall be transferred on opposite end of the piece.

*R. Vaideeswaran*

DI. R. VAIDEESWARAN,  
 Manager

Plant Up / Quality

Q: PL: CP 007

# REMOVAL OF TR. TENSILE SPECIMEN FROM PFP TEST PLATE

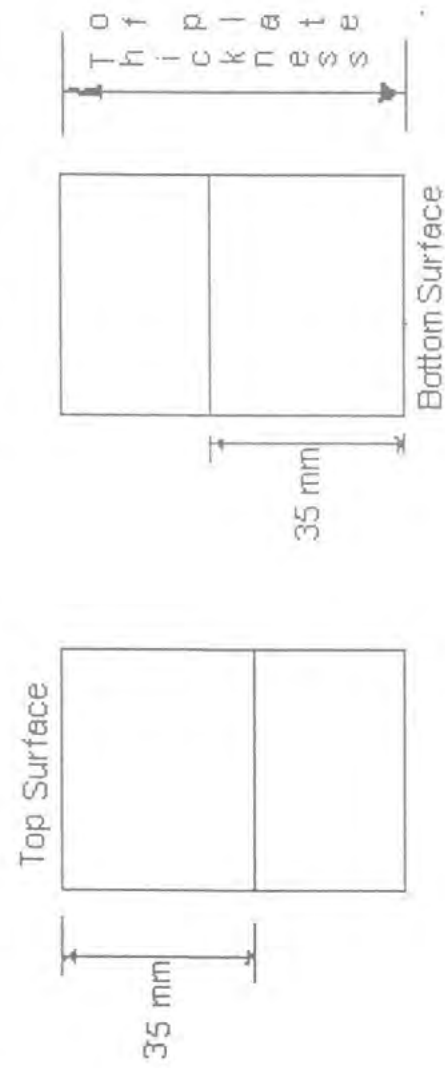

**Note:**

- Thermal cutting (gas, plasma etc) is not allowed.
- Proper identification shall be transferred on the specimen with transfer of Inspector's seal.
- Boiler Inspector's seal shall be transferred on one end of the specimen.

Q: PL: CP: 007

*R. Vaideeswaran*  
**Dr. R. VAIDEESWARAN,**  
 Manager  
 Plant Lab / Quality  
 BHEL, Trichy- 620 014

ORDER REMOVAL OF TRANSVERSE BEND SPECIMENS FROM PRODUCTION TEST COUPON

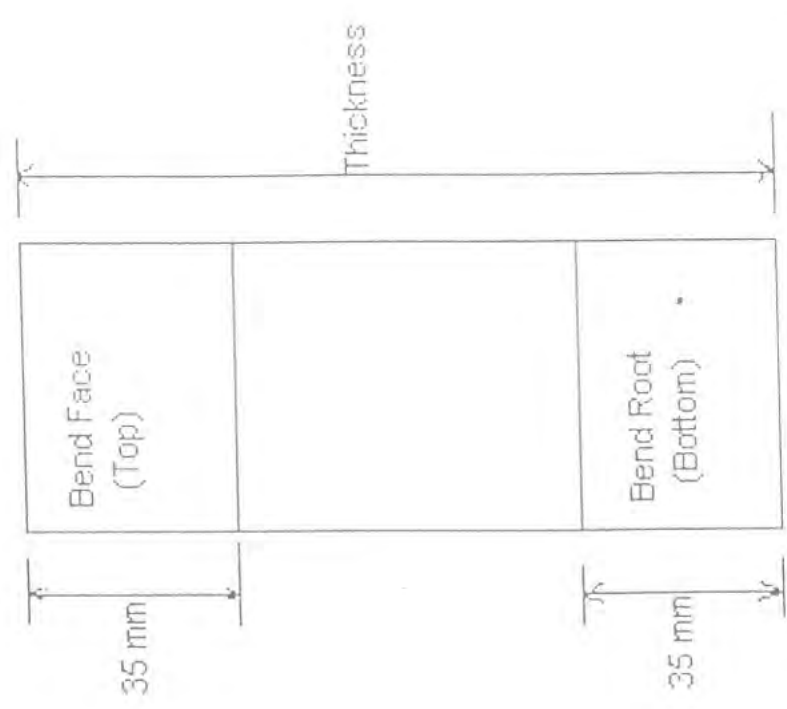

NOTE:

- 1. HACKS/W CUTTING ONLY IS PERMITTED.
- 2. THERMAL (GAS, PLASMA ETC) IS NOT ALLOWED.
- 3. PROPER IDENTIFICATION WITH BOILER INSPECTOR'S SEAL SHALL BE TRANSPORTED IN THE ORIGINAL.

*R. Vaideeswaran*

Dr. R. VAIDEESWARAN,  
Manager

Plant Lab / Quality  
BHEL, Techno. Soc. Co.

Q: PL: CP 009

ORDER OF REMOVAL OF TENSILE SPECIMENS FROM PLATES OF THICKNESS MORE THAN 60 MM TO 90 MM

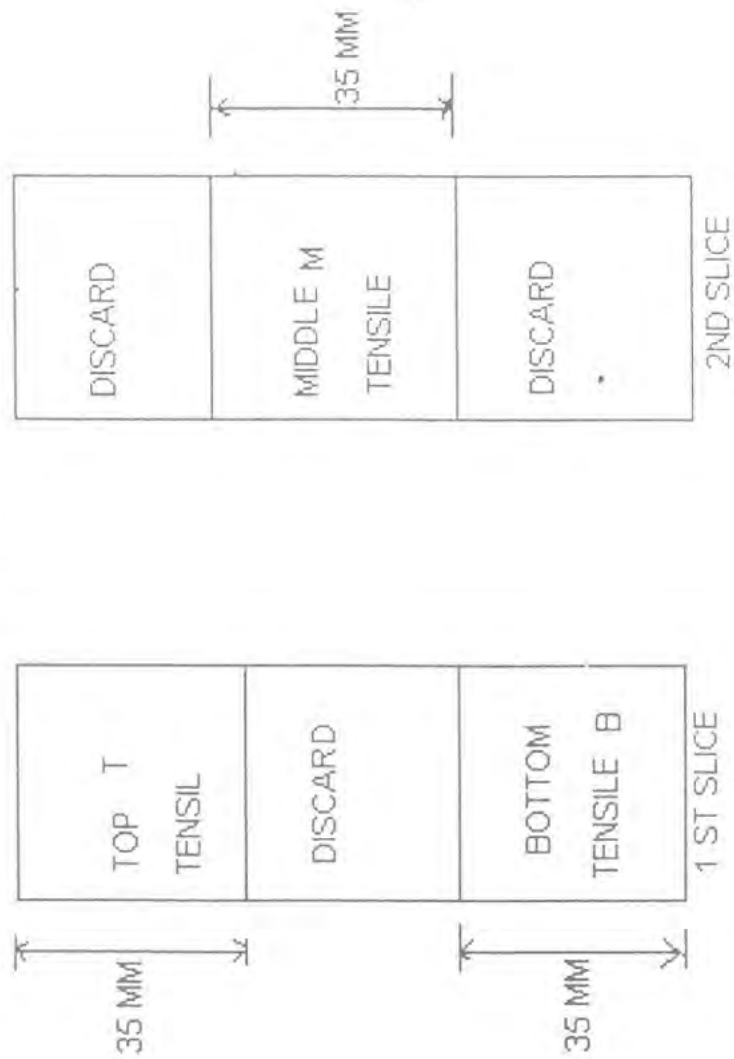

NOTE:

1. HACKSAW CUTTING ONLY IS PERMITTED.
2. THERMAL (GAS, PLASMA ETC) IS NOT ALLOWED.
3. PROPER IDENTIFICATION WITH BOILER INSPECTOR'S SEAL SHALL BE TRANSFERRED ON THE SPECIMEN.

\* MTL No.; Specimen No. and Inspector's seal

*P. Vaideeswaran*  
**P. R. VAIDEESWARAN,**  
Manager

ORDER REMOVAL OF TENSILE SPECIMENS FROM PLATES OF THICKNESS MORE THAN 90 MM TO 120 MM

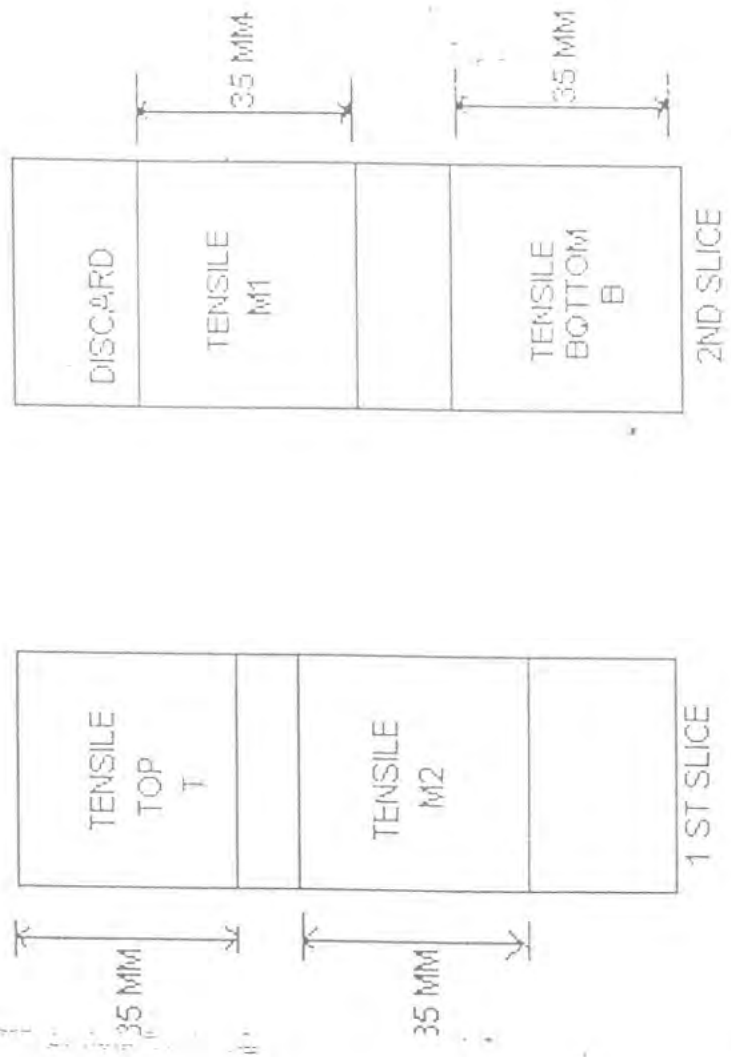

NOTE:

- 1. HACKSAW CUTTING ONLY IS PERMITTED.
- 2. THERMAL (GAS, PLASMA ETC) IS NOT ALLOWED.
- 3. PROPER IDENTIFICATION WITH BOILER INSPECTOR'S SEAL SHALL BE TRANSPORTED TO THE SPECIMEN

Dr. R. VAIDEESWARAN,  
Manager  
Plant Lab / Quality

### REMOVAL OF TRANSVERSE TENSILE SPECIMENS FROM TEST COUPON SLICE FOR THICKNESS > 90 - 150 MM

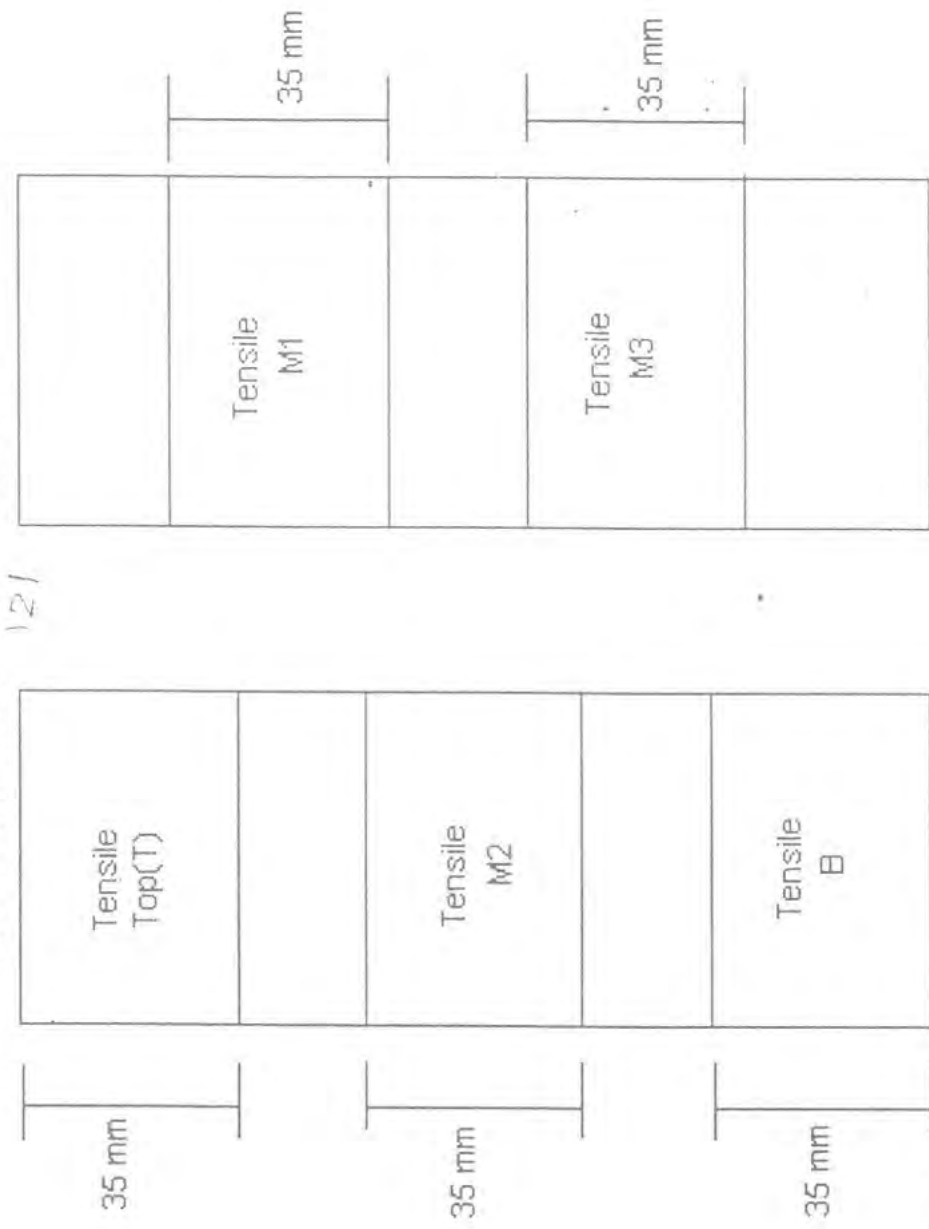

Note:

- Thermal cutting like gas, flame, plasma etc are not allowed.
- Proper identification shall be transferred on one end of the slice.
- Inspector's seal shall be transferred on other end of the slice.

**DR. R. VAIDEESWARAN,**  
Manager  
Plant Quality

**REMOVAL OF TRANSVERSE TENSILE SPECIMENS FROM TEST COUPON SLICE  
FOR THICKNESS > 150 - 175 MM**

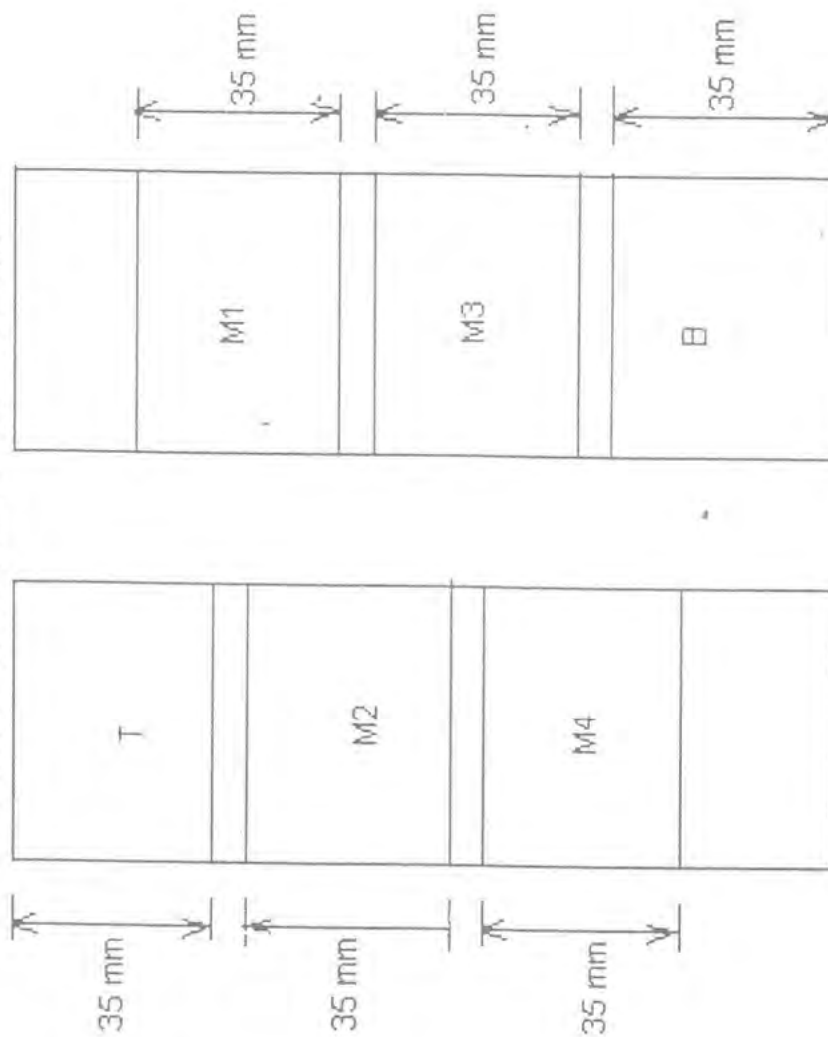

**NOTE:**

- Thermal cutting like gas, flame, plasma etc. are not allowed.
- Proper identification shall be transferred on one end of the slice.
- Inspector's seal shall be transferred on other end of the slice.

*R. Vaideeswaran*

**LT. R. VAIDEESWARAN,**  
Manager  
Plant Lab / Quality

### REMOVAL OF TRANSVERSE TENSILE SPECIMENS FROM TEST COUPON SLICE FOR THICKNESS 175 - 210 MM

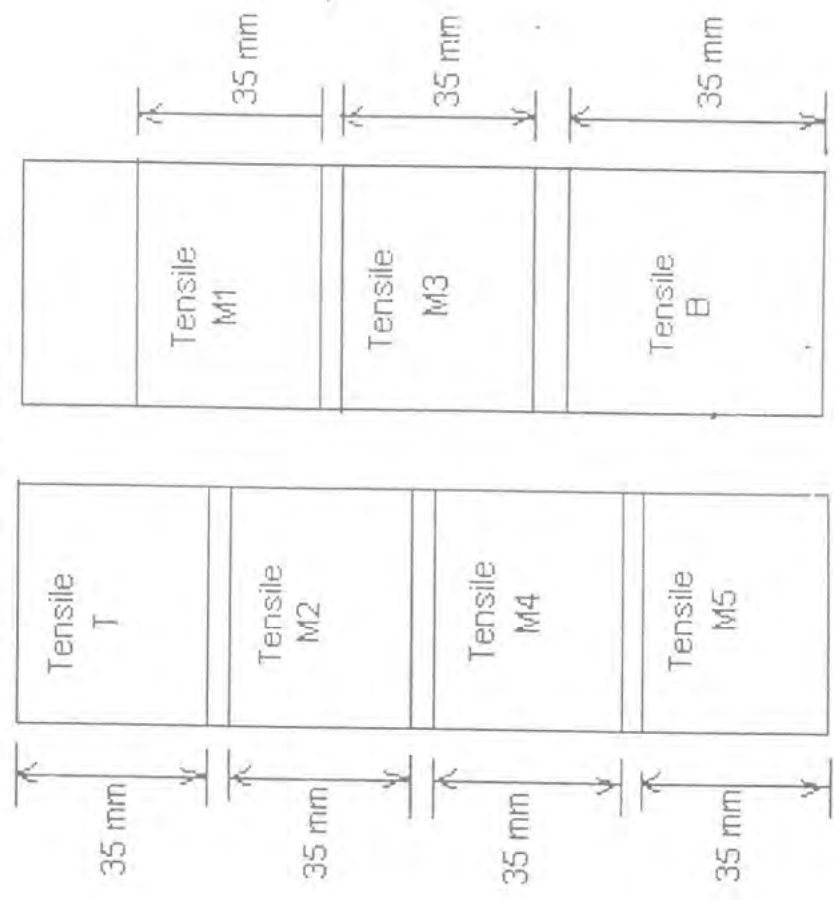

**NOTE:**

- Thermal cutting like gas, flame, plasma etc. are not allowed.
- Proper identification shall be transferred on one end of the slice.
- Inspector's seal shall be transferred on other end of

*P. Vaideeswaran*

**Dr. R. VAIDEESWARAN,**  
Manager

### CUTTING PLAN FOR RAW MATERIAL PLATE

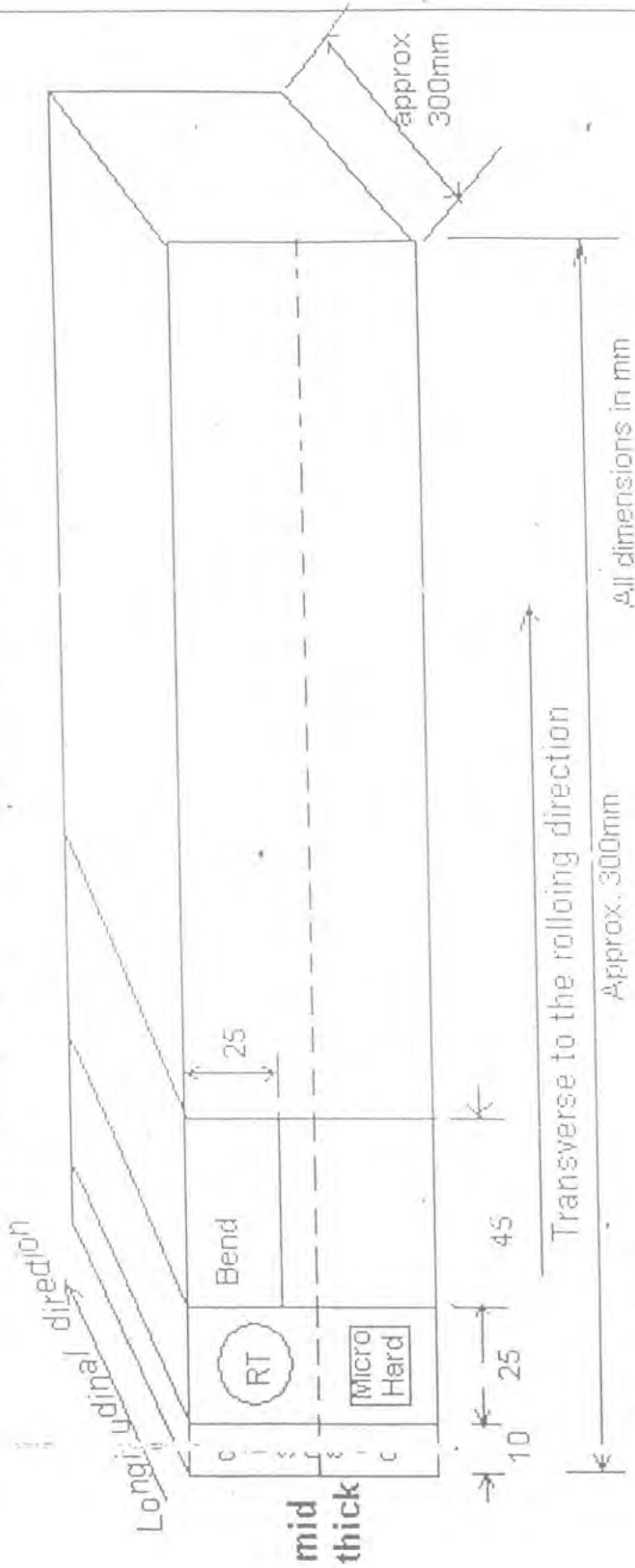

Cutting allowance 5 mm

- If cutting is done exactly perpendicular and no taper is present across thickness, no milling is required for Bend specimen slices.
- No thermal cutting (Gas, Plasma etc) is allowed.
- Preserve balance material with proper identification with transfer of Inspector's Seal
- All specimens shall be taken along the transverse to the rolling direction
- Proper identification shall be transferred on slices.
- Boiler Inspector/TPI seal to be transferred on specimens if required.
- In case of rectangular tensile and bend specimens, from top and bottom original rolling surface must be retained.

*U. R. Vaideeswaran*

**U. R. VAIDEESWARAN,**  
 Manager  
 Plant Lab / Quality

Q: PL: CP 015

CUTTING PLAN FOR RAW MATERIAL PLATE

Longitudinal direction w.r.t rolling

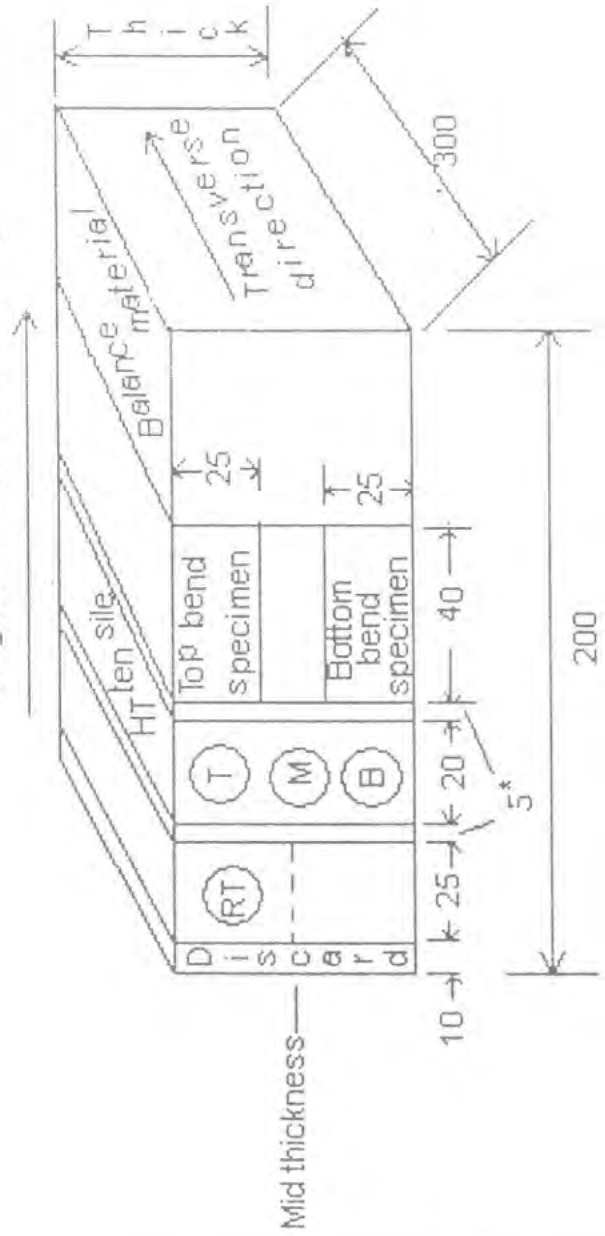

Specification: As punched on the plate - CS/AS/SS - SA 299/SA 515 Gr.70/A36M5

All dimensions are in mm

NOTE:

\* Cutting allowance 5 mm

- If cutting is done exactly perpendicular and no taper is present across thickness, no milling is required for Bend specimen slices.
- No thermal cutting (Gas, Plasma etc) is allowed.
- Preserve balance material with proper identification with transfer of Inspector's Seal
- All specimens shall be taken along the transverse to the rolling direction
- Proper identification shall be transferred on slices.
- Boiler Inspectorate/TPI seal to be transferred on specimens if required
- In case of rectangular tensile and bend specimens, from top and bottom, original rolling surface must be retained

*R. Vaideeswaran*  
**Dr. R. VAIDEESWARAN,**  
 Manager  
 Plant Lab / Quality  
 BHEL., Trichy- 620 014

LOCATION WHERE TENSILE SPECIMEN TO BE TAKEN FROM ROD/BAR

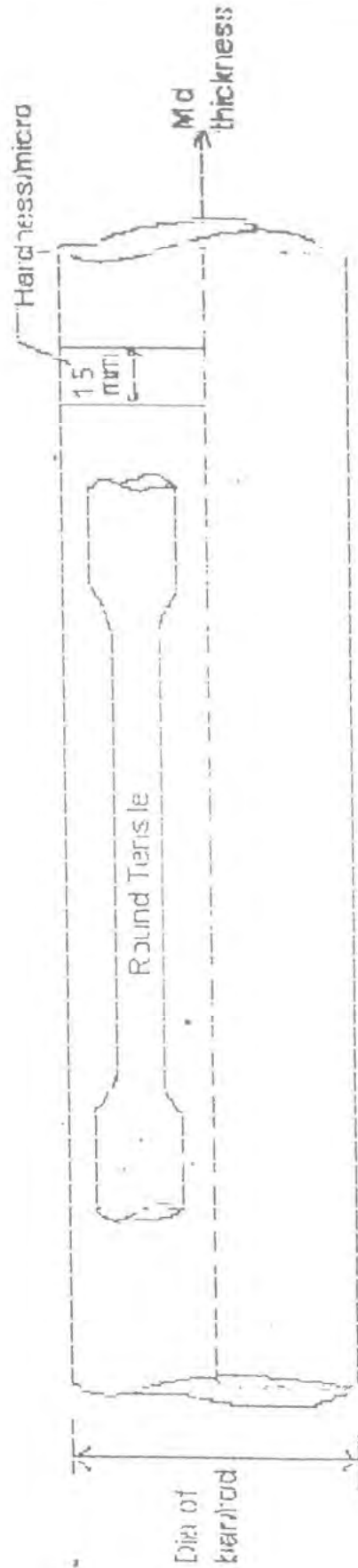

Note: Round tensile specimen is to be taken at midway between mid thickness end one surface

Hardness/micro shall also be taken at the same location

Hot saw cutting shall be used. No thermal (gas, flame, plasma etc) shall not be permitted.

Proper identification shall be transferred on the balance piece as well as on the specimen

cut piece.

Inspector's if required shall be transferred

*R. Vaideeswaran*

**Dr. R. VAIDEESWARAN,**

Manager

Plant Lab / Quality



Q: PL: SP 002

### TRANSVERSE BEND SPECIMEN FOR PLATE

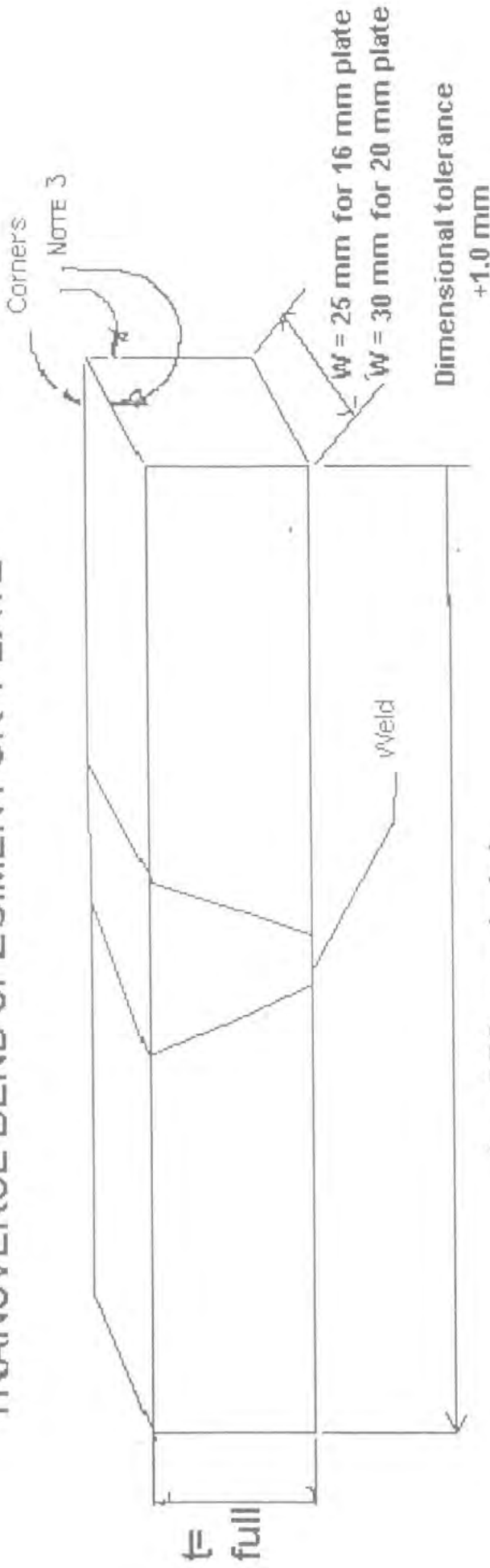

1. Excess weld to be flushed off on Top and Bottom and made smooth by milling machine or by Hand grinding or by other suitable means.
2. If both cut surfaces are parallel, milling is not required on both sides.
3. Rounding off all corners to 1 to 3 mm radius
4. No transverse milling/tool marks permitted.
5. Thermal cutting is not permitted.
6. Proper identifications to be transferred on the specimens.

*P. Vaideeswaran*  
**Dr. R. VAIDEESWARAN,**  
 Manager  
 Plant Lab. Quality  
 BHEL., Trichy 620 014

Q. PL. SP: 003

### MACRO SPECIMEN FOR DRUM/PFP TEST PLATE

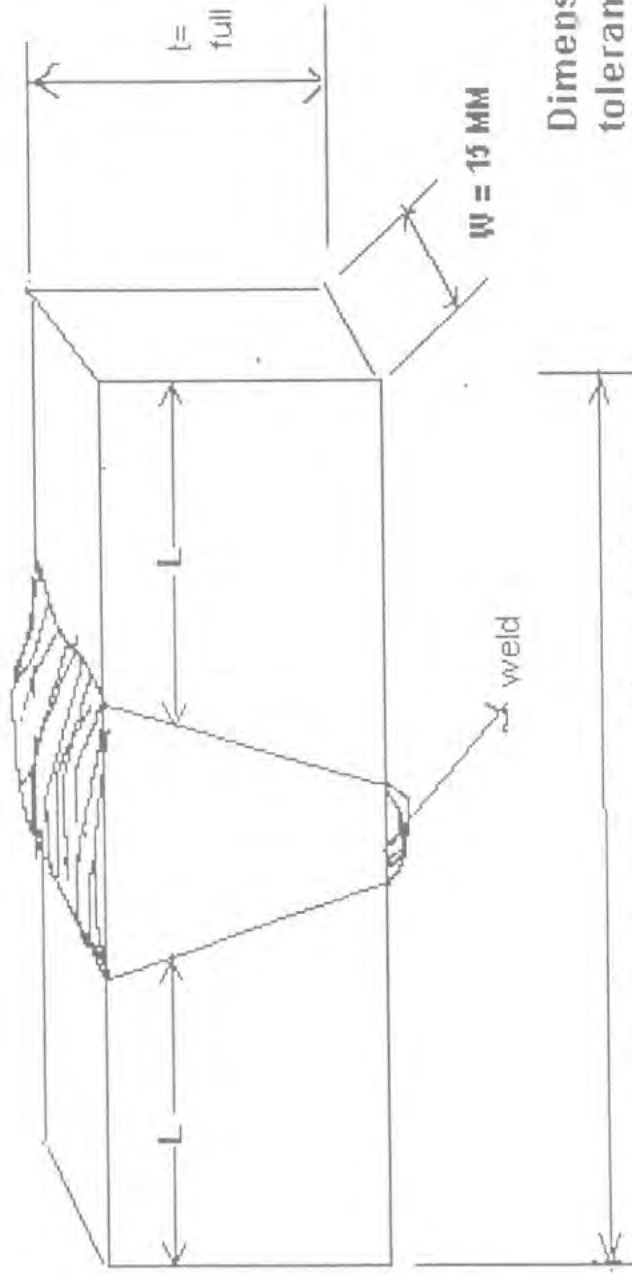

**L = 25mm on either side of the weld metal**

**Dimensional tolerance + 1.0 mm**

- One cut surface of the plate is to be ground by surface grinder (grinding finish).
- Excess weld at Top and Root portion should not be removed.
- Parallel seating should be provided.
- Corners should not be rounded off. Burrs should be removed.

**PROPER IDENTIFICATIONS ARE TO BE TRANSFERRED ON THE SPECIMEN**

QUALITY INSPECTOR'S SEAL

*R. Vaideeswaran*

**DR. R. VAIDEESWARAN,**  
Manager

Flight Lab / Quality

### MICRO SPECIMEN - PLATE

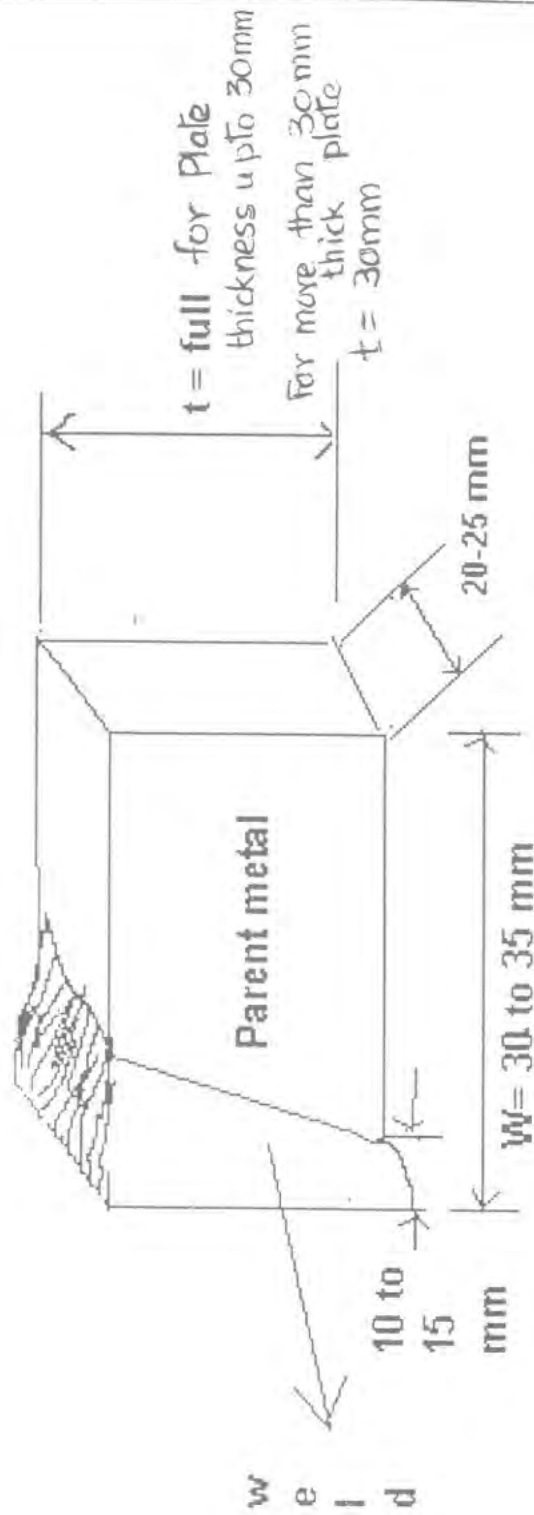

One cut surface should have grinding finish.

Parallelism is required.

Rounding off all corners to 3 mm radius

Excess weld not to be removed.

Proper identifications are to be transferred on the specimen with transfer of Inspector's seal

*R. Vaideeswaran*  
**Dr. R. VAIDEESWARAN,**  
 Manager  
 Plant Lab / Quality

Q: PL: SP 005

### MACRO SPECIMEN FOR PIPE AND TUBE

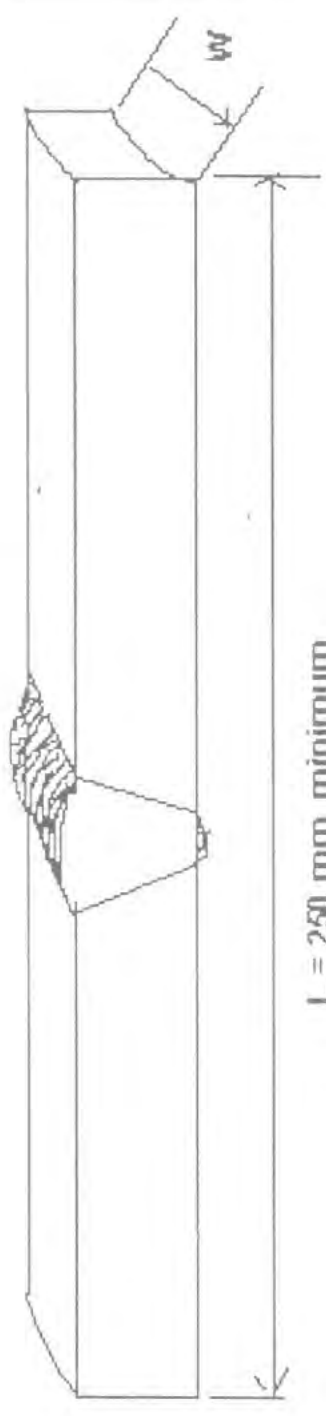

$w$  for Pipe = 36 mm  
 $w$  for Tube = 25 mm

- Thermal cutting not permitted
- Corners not to be rounded off.
- Excess weld on top and bottom not to be flushed off
- Grinding finish required for one cut side of the specimen.
- Proper identification marks to be transferred on the specimen.

*R. Vaideeswaran*  
**Dr. R. VAIDEESWARAN,**  
 Manager  
 Plant Lab / Quality  
 BHEL, Trichy- 620 014

18

Q: PL: SP 006

# TRANSVERSE BEND SPECIMEN-PIPE AND TUBE

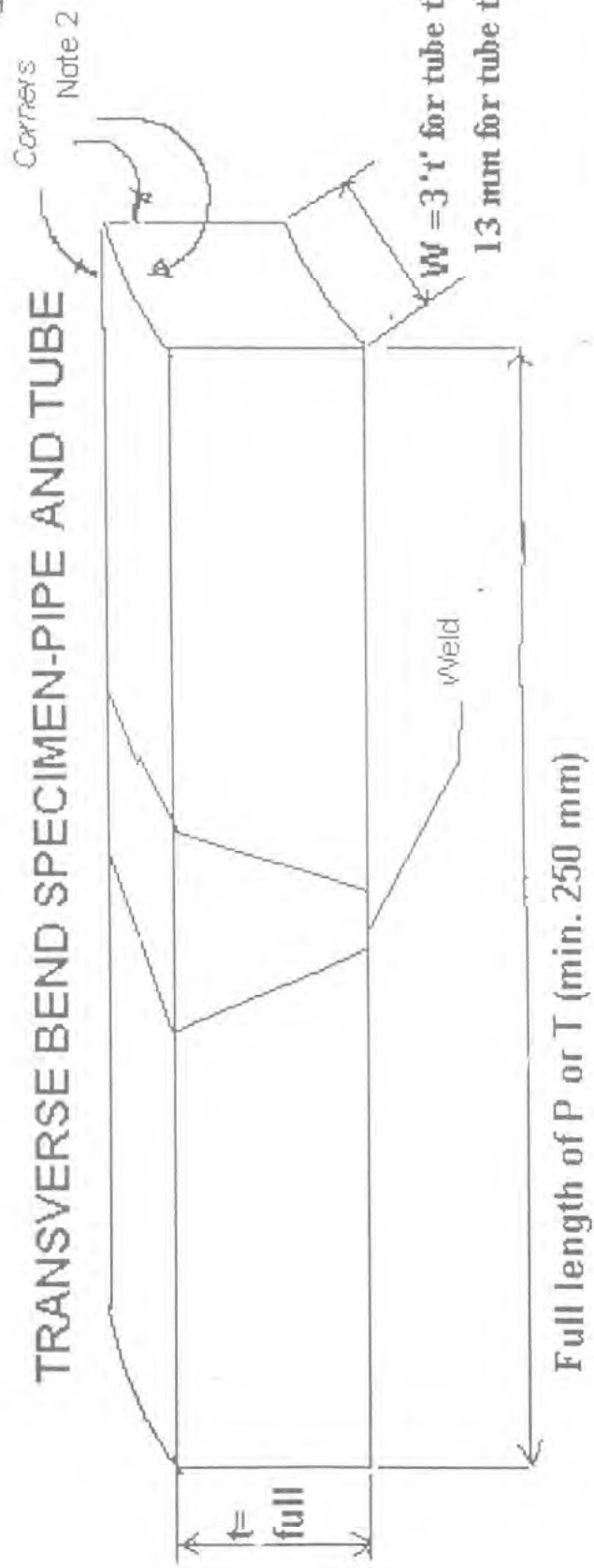

Dimensional tolerance  $\pm 1.0$  mm

1. All cut surfaces are to be machined on a milling m/c. If both cut surfaces are parallel, milling on cut surfaces is not required.
2. Round off all corners to 1 to 3 mm.
3. Weld reinforcements and penetrations should be removed and made smooth by milling/Hand grinding/other suitable means.
4. No transverse milling and tool marks permitted.
5. Thermal cutting is not allowed.
6. Proper identifications to be transferred on the specimen.

*R. Vaideeswaran*  
**Dr. R. VAIDEESWARAN,**  
 Manager  
 Plant Lab / Quality  
 BHEL, Trichy - 620 014

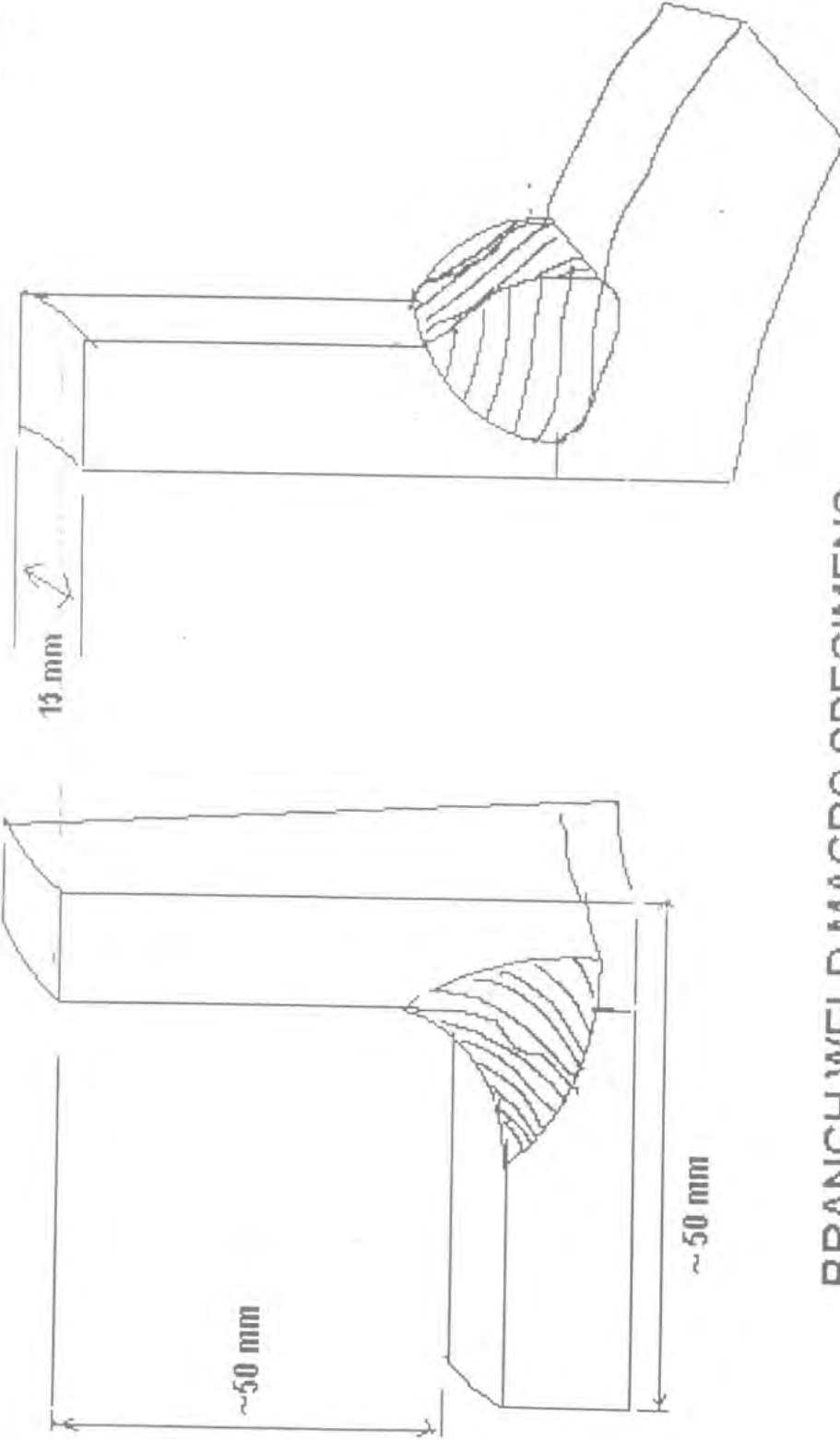

### BRANCH WELD MACRO SPECIMENS

One cut surface of each specimen to have grinding finish.

Specimens must have parallelism.

Thermal cut (gas/plasma) not allowed.

Proper identifications are to be transferred on the specimen.

# Transverse Tensile Specimen

Q: PL: SP 008

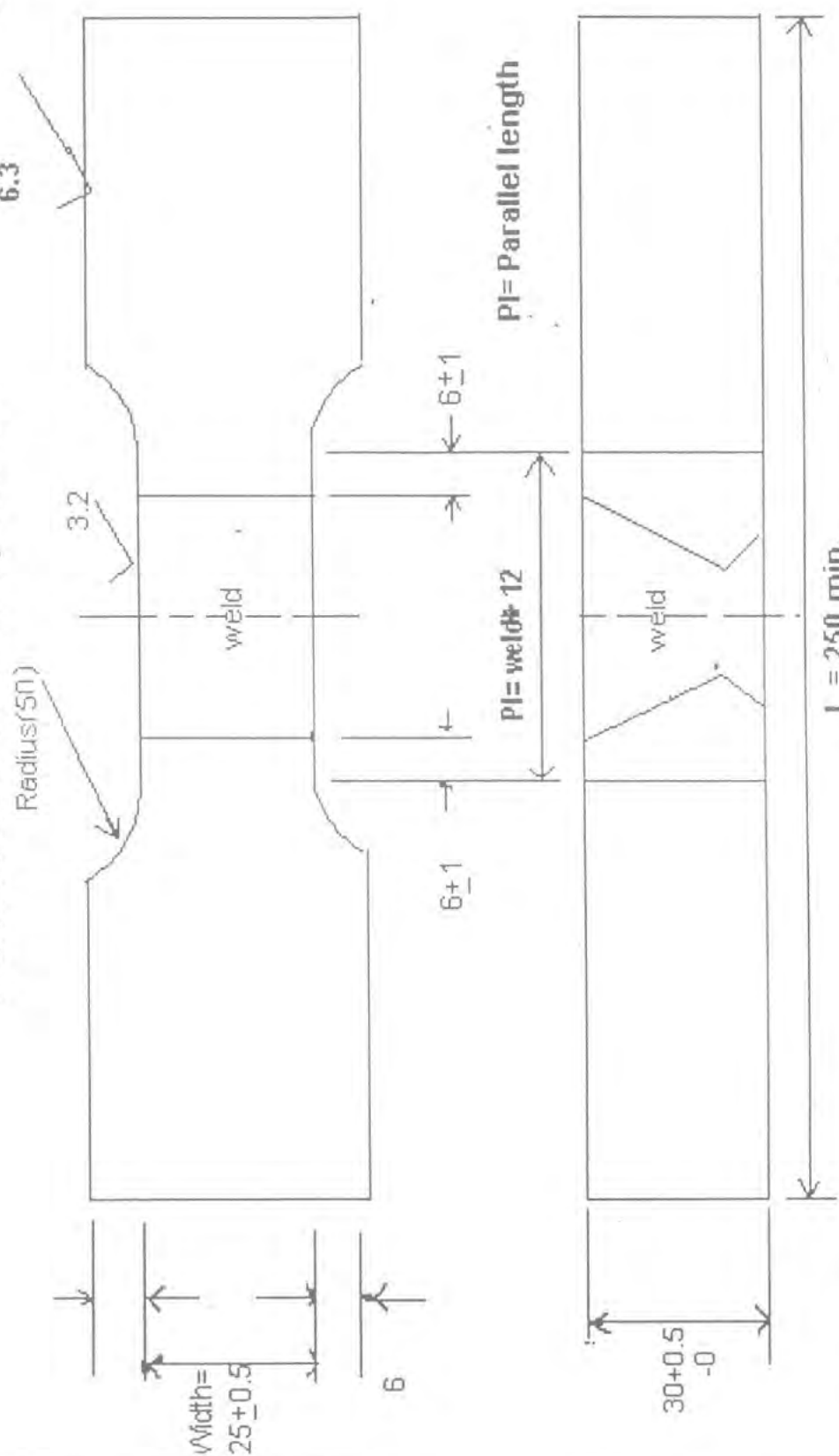

Burrs should be removed.

If cutting on either side of the specimen is parallel, milling on cut surfaces is not required.

Thermal cutting is not allowed. Radius should be smooth.

Polish the reduced section after milling using belt polisher

No transverse milling/tool marks permitted.

Proper identifications to be transferred on the specimen MTL No: specimen no; Inspector's seal

All dimensions are in mm

*Dr. R. Vaideeswaran*

**Dr. R. VAIDEESWARAN,**  
Manager

Manager

### All Weld Metal Test Specimen

Q: PL: SP 009

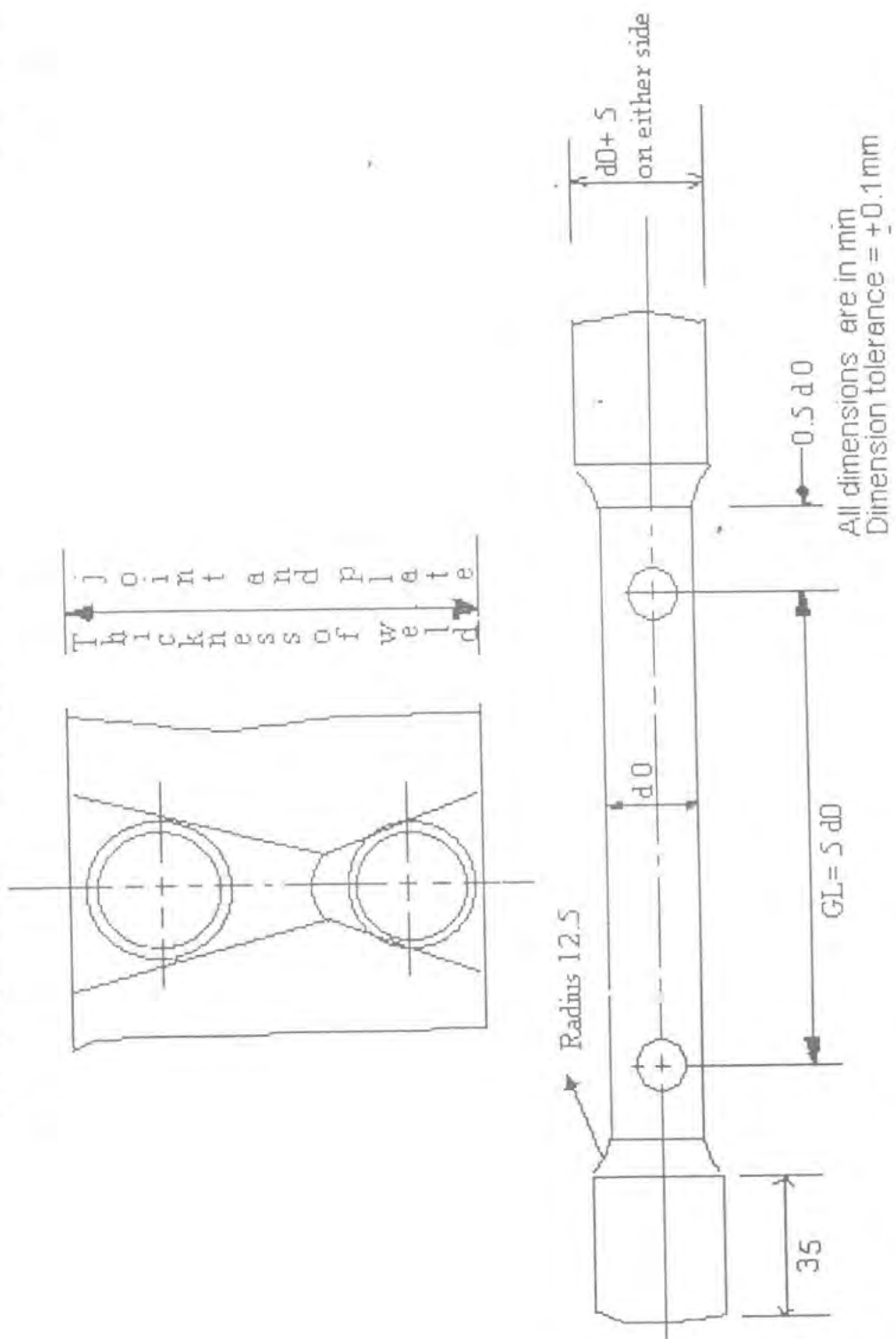

- Note:
1. Proper identification shall be transferred on both ends, with transfer of Inspector's seal
  2. Reduced portion of the tensile specimen shall have smooth surface.
  3. Tool marks are not allowed on the reduced portion of the tensile specimen.

*R. Vaideeswaran*

**Dr. R. VAIDEESWARAN,**  
Manager

Plant Lab / Quality  
BHEL, Trichy. 620 014

Q: PL: SP 010

Impact Specimen Dimensions

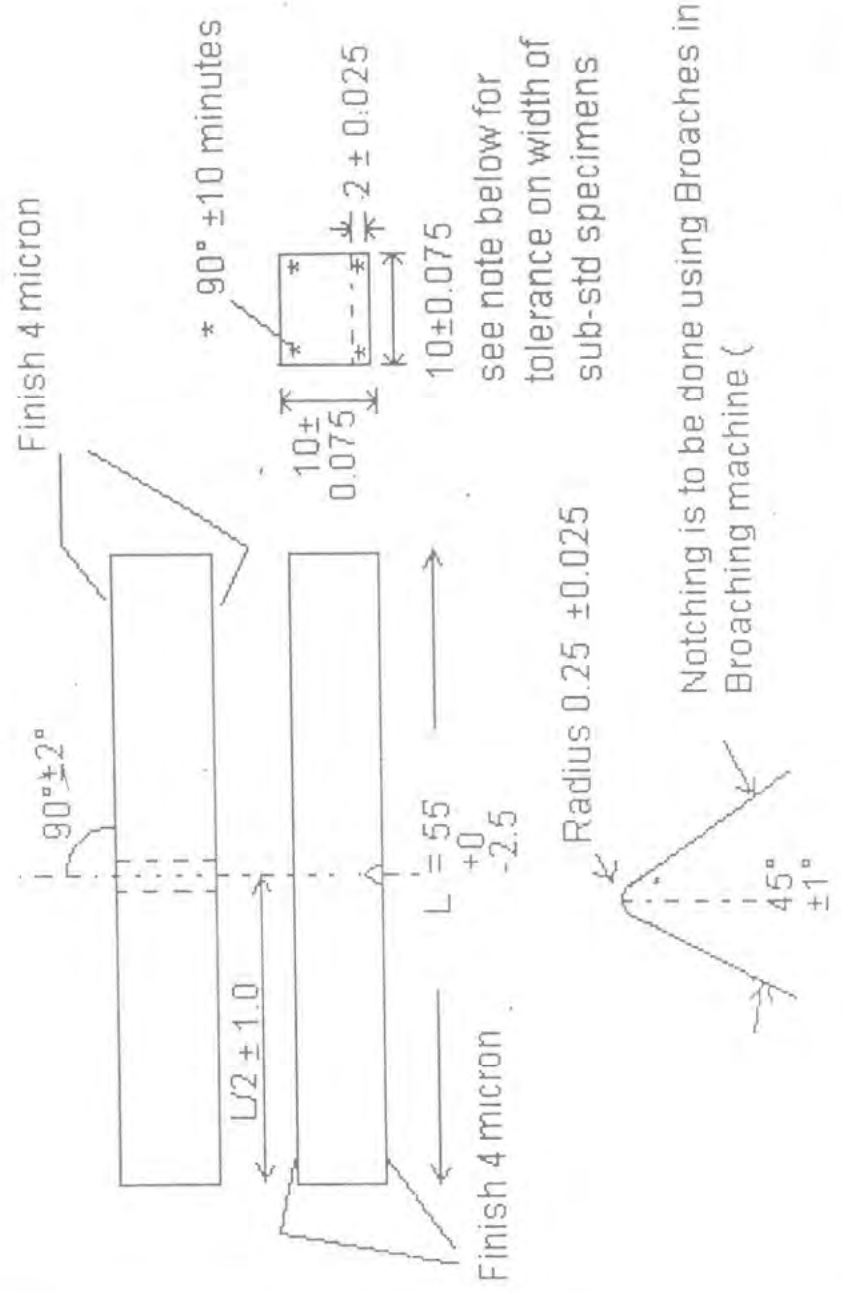

see note below for tolerance on width of sub-std specimens

Sub-standard sizes when allowed: 2.5 mm, 3.3 mm, 5.0 mm, 6.7 mm, 7.5 mm

Tolerance on width  $\pm 1.0\%$

*R. Vaideeswaran*

Dr. R. VAIDEESWARAN,  
Manager  
Plant Lab / Quality

# TRANSVERSE BEND SPECIMEN

Q: PL: SP 011

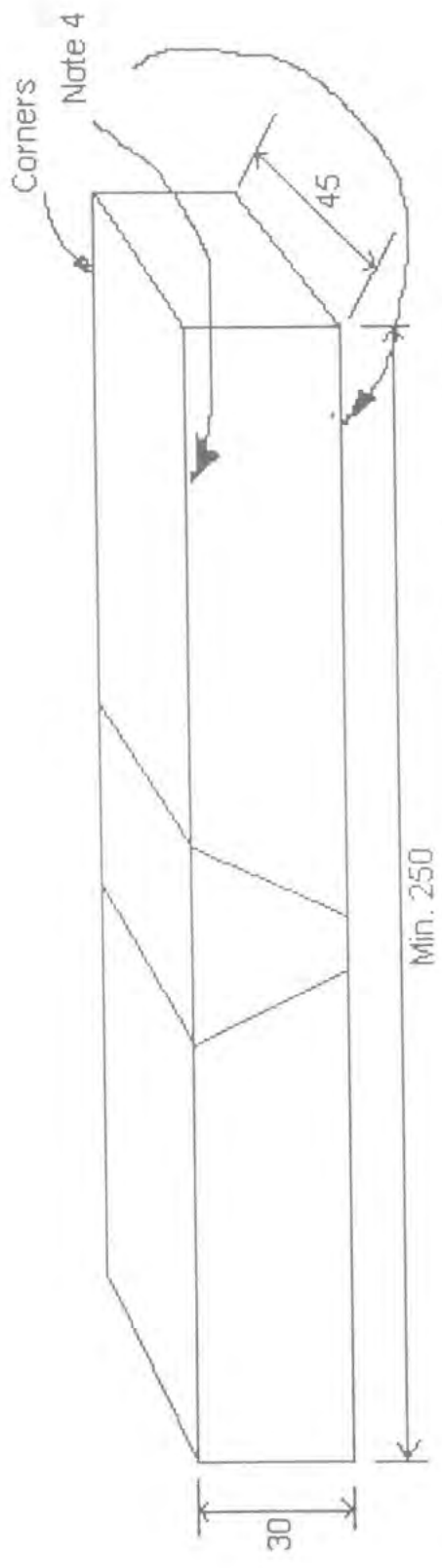

All dimensions are in mm  
 Dimensional tolerance  $\pm 1.0$  mm

**Note:**

- 1 All cut surfaces are to be machined on a milling machine. If both cut surfaces are parallel, milling on cut surfaces is not required.
- 2 Proper identification shall be transferred on the specimen with transfer of Inspector's seal
- 3 Thermal cutting (gas/plasma etc) is not allowed.
- 4 Round off all corners to radius 1 to 3 mm
- 5 No transverse tool marks and milling marks permitted.
- 6 Boiler Inspectorate seal shall be transferred on one end of the specimen

**D. R. VAIDEESWARAN,**  
 Manager  
 Plant Laboratory  
 BHEL, Trichy-613004

# HIGH TEMPERATURE TENSILE

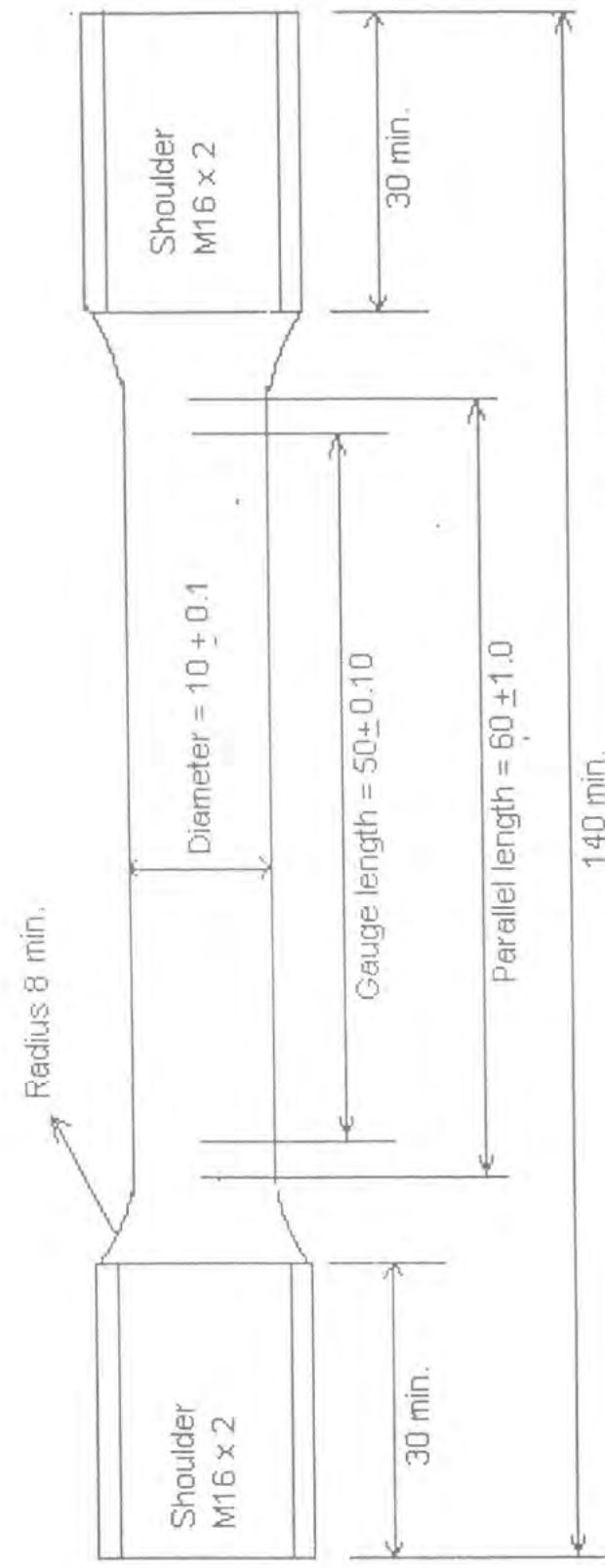

All dimensions are in mm

**Note:**

- Proper identification shall be transferred on the specimen on both ends with transfer of Inspector's seal
- Burrs are to be removed from the threaded portion. Thread should suit the holder at Plant lab.
- Reduced portion of the Tensile specimen shall have smooth surface.
- Tool marks are not allowed on the reduced portion of the tensile specimen.
- Boiler Inspectorate seal shall be transferred on one end of the specimen.

*R. Vaideeswaran*

**Dr. R. VAIDEESWARAN,**  
Manager

Plant Lab / Quality  
SHEL, Trichy, 520 011

### ROUND TENSILE SPECIMEN

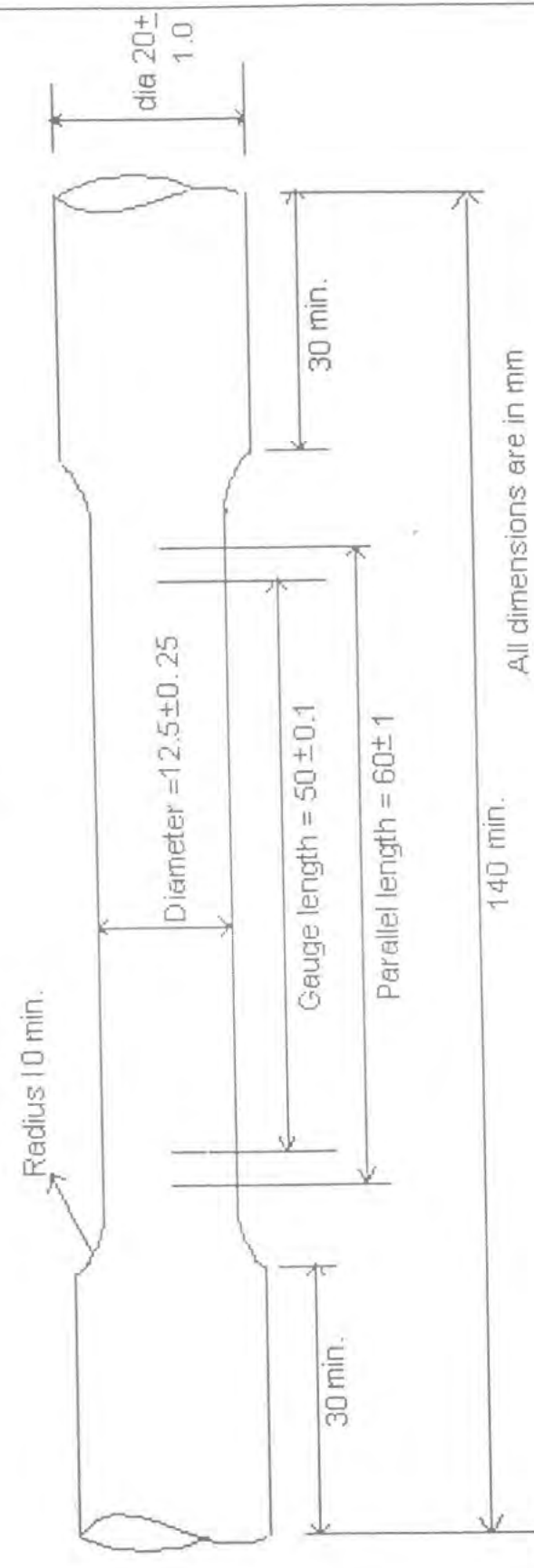

All dimensions are in mm

**Note:**

- Proper identification shall be transferred on the specimen on both ends with transfer of Inspector's seal.
- Reduced section of the Tensile specimen shall have smooth surface.
- Tool marks are not allowed on the reduced section of the tensile specimen
- Boiler Inspectorate seal shall be transferred on one end of the specimen
- The reduced section may have a gradual taper from the ends toward the center, with the ends not more than 1 percent larger in diameter than the center (controlling dimension).

*R. Vaideeswaran*

**Dr. R. VAIDEESWARAN,**  
 Manager  
 Plant Lab / Quality  
 BHEL, Trichy - 620 014

## TRANSVERSE BEND SPECIMEN

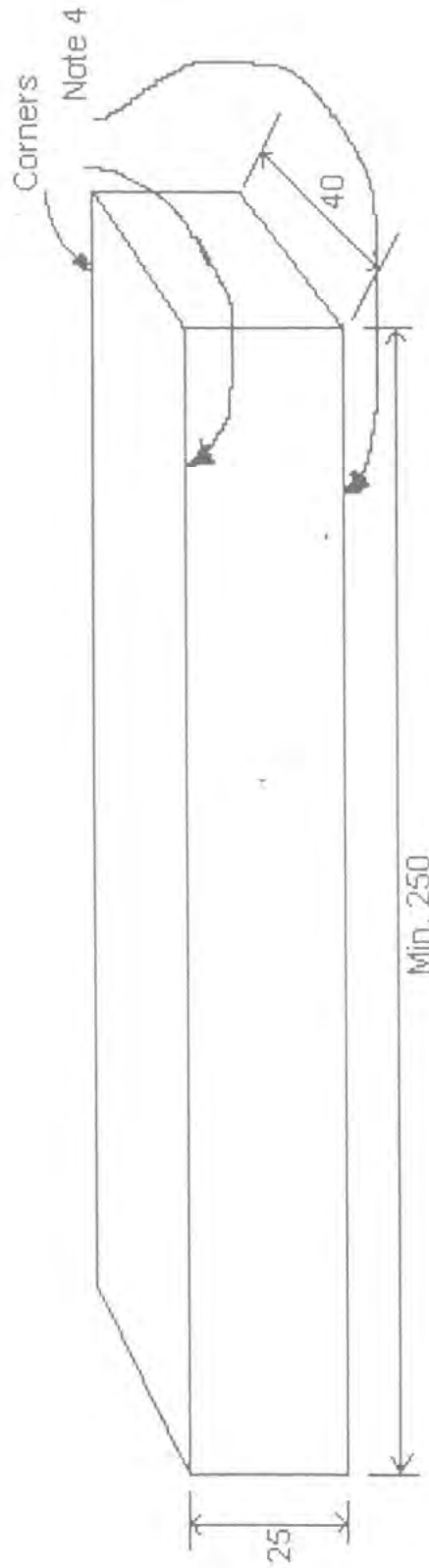

All dimensions are in mm

Dimensional tolerance  $\pm 1.0$  mm

Note:

- 1 All cut surfaces are to be machined on a milling machine. If both cut surfaces are parallel, milling on cut surfaces is not required.
- 2 Proper identification shall be transferred on the specimen with transfer of Inspector's seal
- 3 Thermal cutting (gas/plasma etc) is not allowed.
- 4 Round off all corners to radius 1 to 3 mm
- 5 No transverse tool marks and milling marks permitted.
- 6 Boiler Inspectorate seal shall be transferred on one end of the specimen
- 7 For Top Bend specimen top original surface and for bottom bend specimen bottom original surface shall be preserved.

*R. Vaideeswaran*

**Dr. R. VAIDEESWARAN,**  
Manager

Plant Lab / Quality  
RHEL, Trichy- 620 014

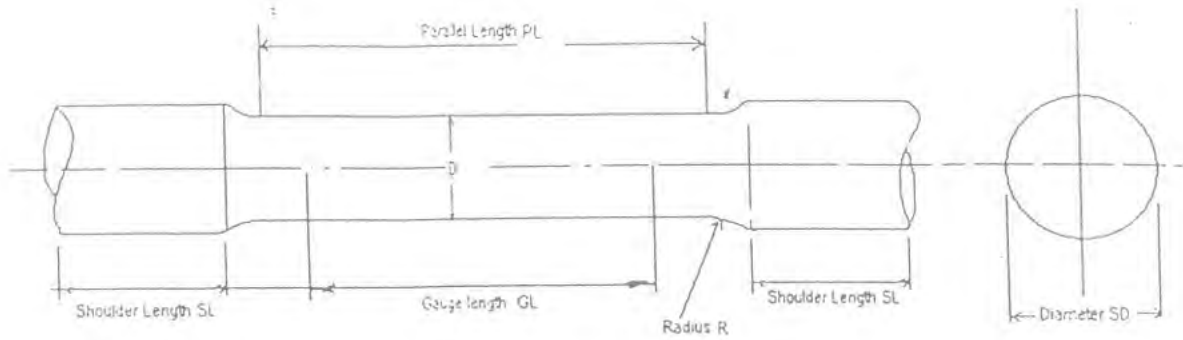

Parameter	Dimensions in mm			
D (Note1)	12.5 ± 0.25	8.75 ± 0.18	6.25 ± 0.12	4.0 ± 0.08
SD	20.0±1.0	15.0±1.0	12.0±1.0	8.5±0.5
GL	50.0± 0.10	35 ± 0.10	25.0 ± 0.10	16.0± 0.10
R minimum	10	6	5	4
PL minimum	60	45	32	20
SL minimum	30	25	20	15

Note

1. The reduced section may have a gradual taper from the ends toward the center, with the ends not more than 1 percent larger in diameter than the center (controlling dimension)
2. Use enough amount of coolant while turning to avoid heating of specimen
3. Smooth finish without undercuts/steps/turning marks in the reduced section and at the radius regions.
4. Gauge marks are to be punched with a sharp punching tool centered at the parallel length
5. Identification of specimen to be punched at both the ends, keeping specimen in vice and gripping of the shoulder at the ID punching side.

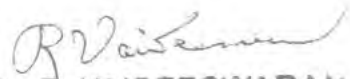
  
**Dr. R. VAIDEESWARAN,**  
 Manager  
 Plant Lab / Quality  
 BHEL, Trichy- 620 014

HARDNESS/MICRO-PIECE/ SPECTRAL

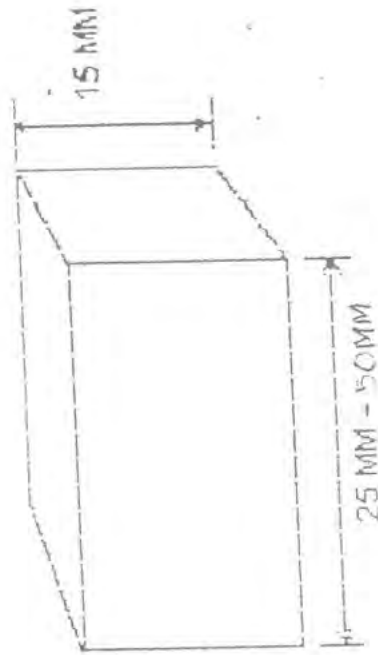

Note: Hacksaw cutting shall be used. No thermal cutting is permitted.

1. Parallelism is required.
2. One cut surface should have grinding finish.
3. Rounding off all corners to 3 mm radius.

*R. Vaideeswaran*

Dr. R. VAIDEESWARAN,  
Manager  
Plant Lab / Quality  
FHEC., Trichy-620 014

(32)

# RECTANGULAR TENSION SPECIMENS

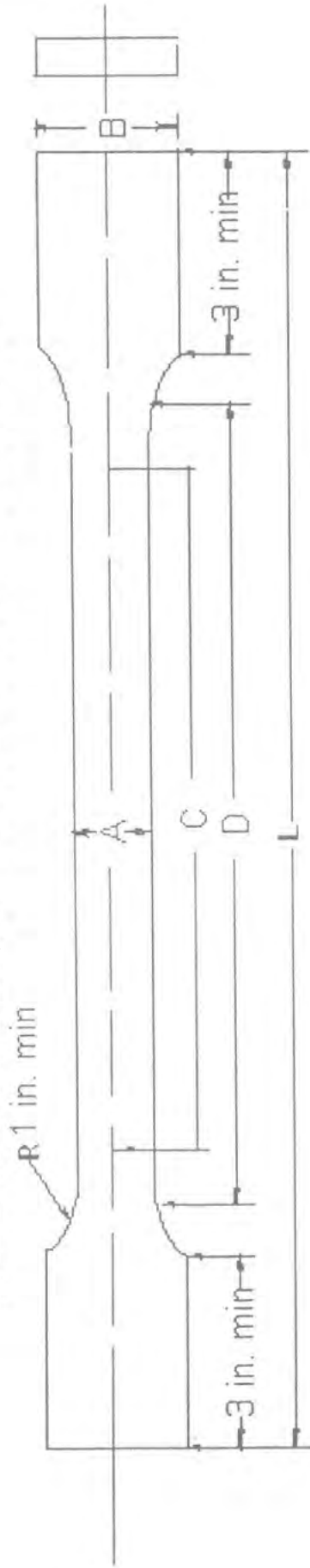

## Dimensions

Specimen No	A	B	C	D
1	1/2 ± 0.015	1 1/16 approximately	2 ± 0.005	2 1/4 min
2	3/4 ± 0.031	1 approximately	2 ± 0.005 4 ± 0.005	2 1/4 min 4 1/2 min
3	1 ± 0.062	1 1/2 approximately	2 ± 0.005 4 ± 0.005	2 1/4 min 4 1/2 min
4	1 1/2 ± 1/8	2 approximately	2 ± 0.005 4 ± 0.005	2 1/4 min 4 1/2 min
3 in. min			8 ± 0.020	8 min

  
**Dr. R. VAIDESWARAN,**  
 Manager  
 Plant In-charge / Quality  
 BHEL, Trichy-620 014

FLARING SPECIMEN

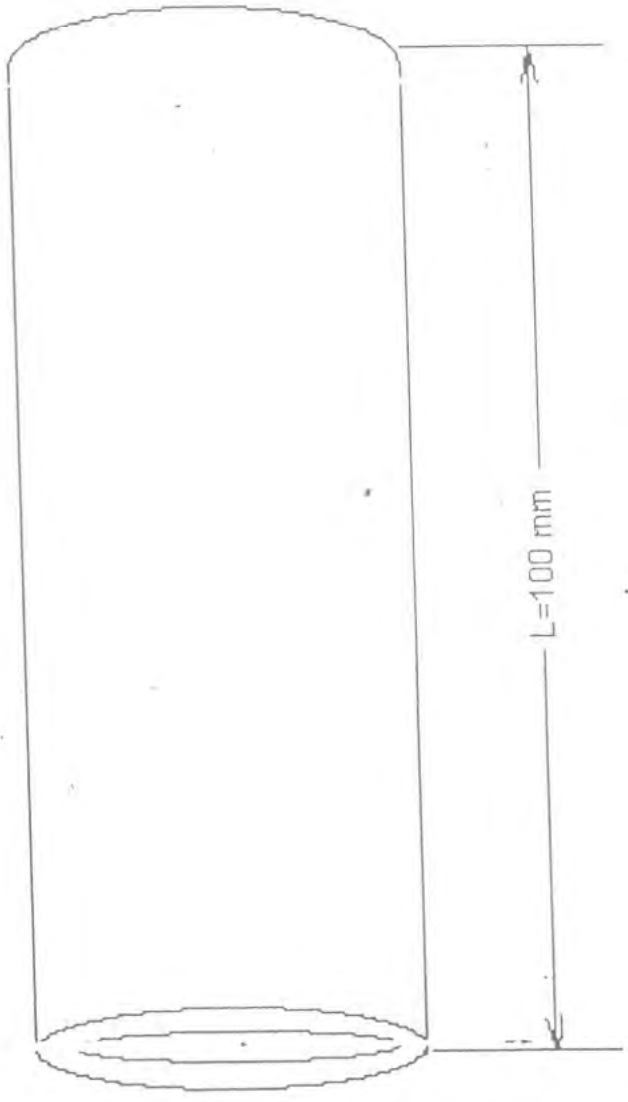

*R. Vaideeswaran*

Dr. R. VAIDEESWARAN,  
Manager  
Plant Lab / Quality  
BHEL, Trichy. 620 014

# FLATTENING SPECIMEN

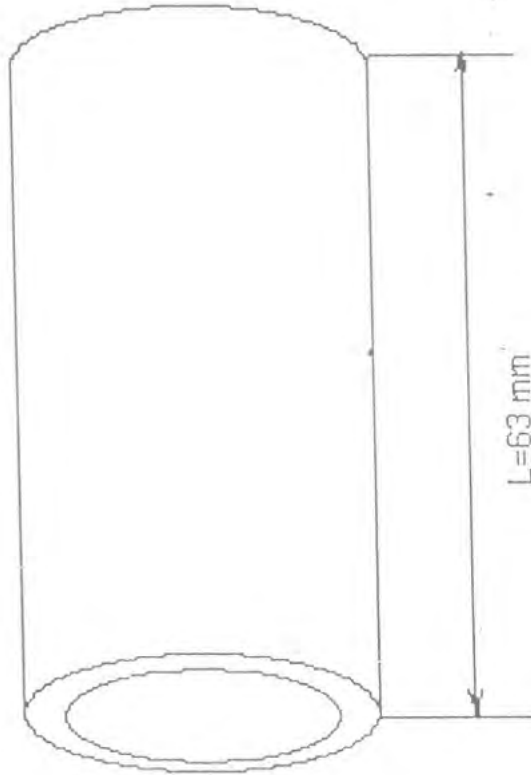

*R. Vasanth*

**Dr. R. VAIDEEESWARAN,**

Manager

Plant Lab / Quality

SHL, Trichy- 620 014

## SIDE BEND SPECIMEN



- Note:
1. Length of the specimen is 300mm
  2. Edges/Corners shall be rounded off to 5mm radius.
  3. Specimen shall be taken across the thickness of the plate

*R. Vaideeswaran*

**Dr. R. VAIDEESWARAN,**

Manager

Plant Lab / Quality

BHEL., Trichy-520 014

60

015

### DELTA FERRITE SPECIMEN

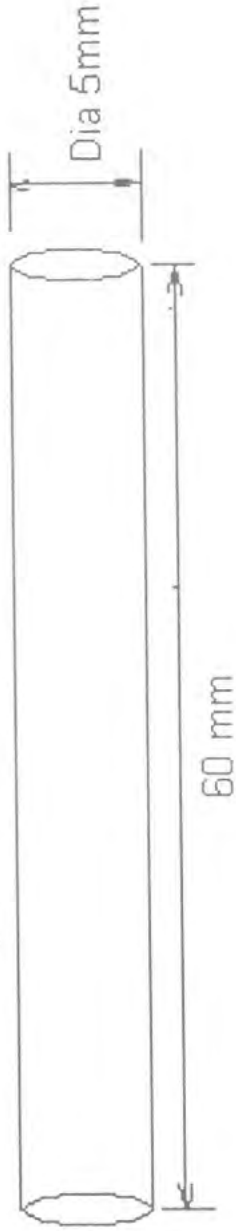

*R. Vaideeswaran*

**Dr. R. VAIDEESWARAN,**

Manager

Plant In-charge

Surf., Trichy-620 014

### IGCT SPECIMEN

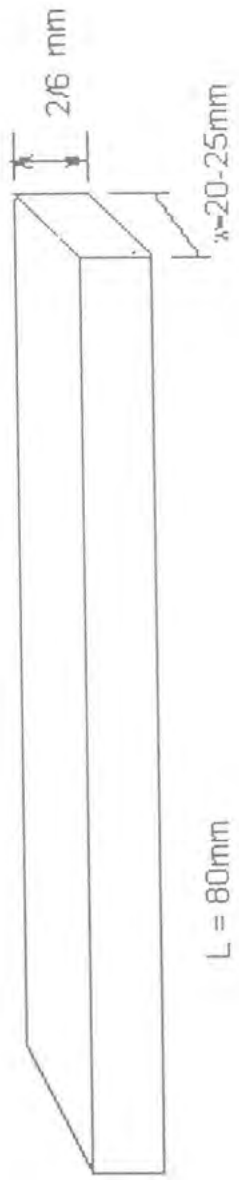

Note: All corners are to be rounded off.  
all surfaces are to be polished using emerysheet to remove the milling marks

*P. Vaideeswaran*

**Dr. R. VAIDEESWARAN,**  
Manager  
Plant Lab / Quality  
BHEL, Tichy- 620 014

### RING MICRO

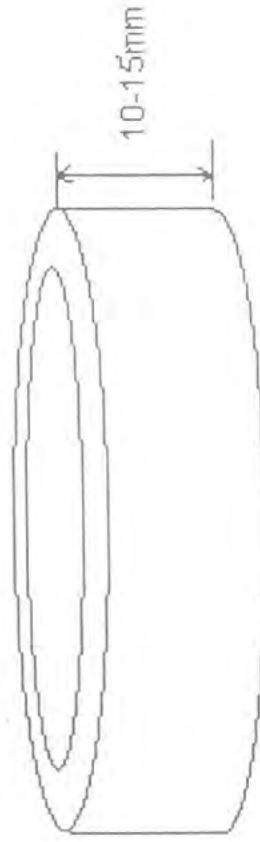

Note: Edges shall be rounded off  
One cut surface shall have ground finish  
Opposite side of the ground surface shall have milling finish with parallel seating.  
Proper identification marks shall be transferred.

*R. Vaideeswaran*

**DR. R. VAIDEESWARAN,**  
Manager  
Plant Lab / Quality

HOUNSFIELD TENSILE SPECIMEN

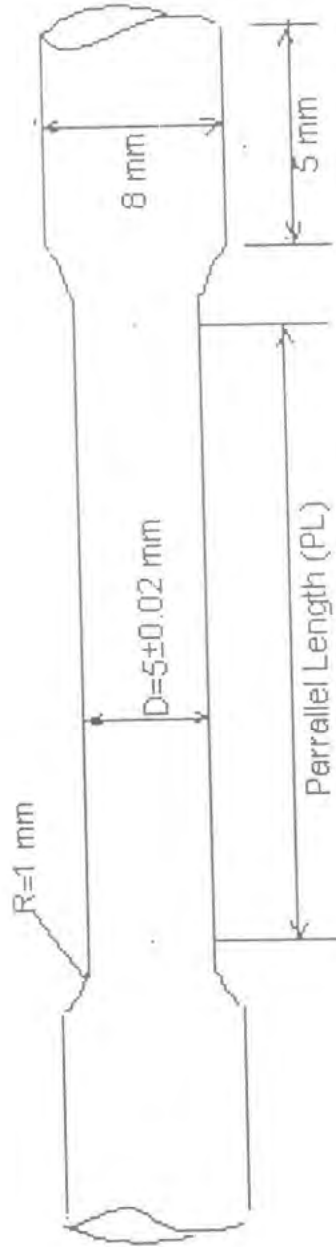

Note : For 4D Specimens, Parallel Length (PL) = 22 mm  
For 5D specimens, Parallel Length (PL) = 27 mm

*R. Vaideeswaran*

Dr. R. VAIDEESWARAN,  
Manager  
Plant Lab / Quality  
BHEL, Trichy-620 014

# ROUND TENSILE TEST (HFT) 4d

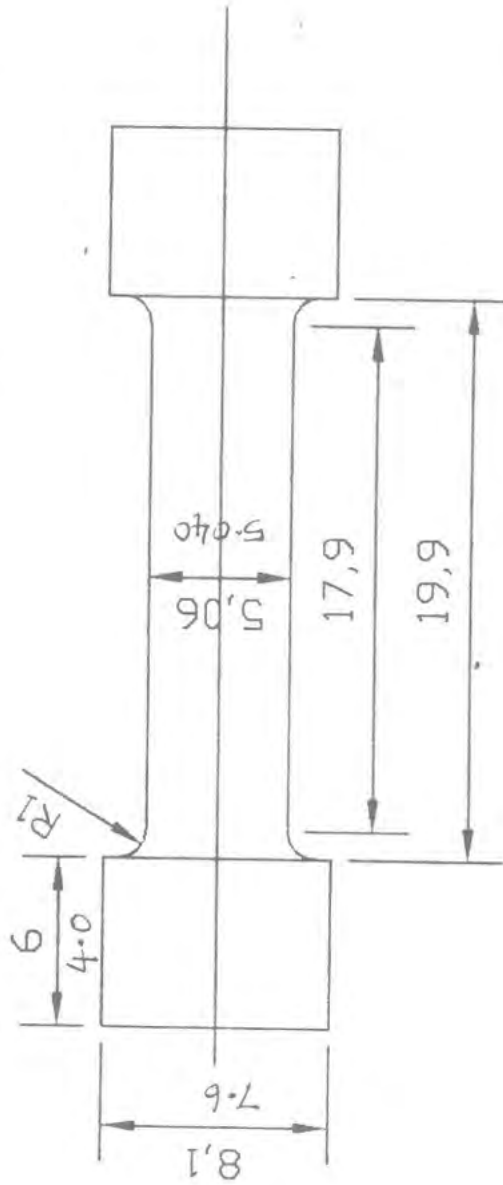

ALL DIMENSIONS ARE IN mm

*V. Vaideeswaran*

**Dr. R. VAIDEESWARAN,**  
Manager  
Plant Lab / Quality  
BHEL, Trichy-620 014

# ROUND TENSILE (HFT) 5d

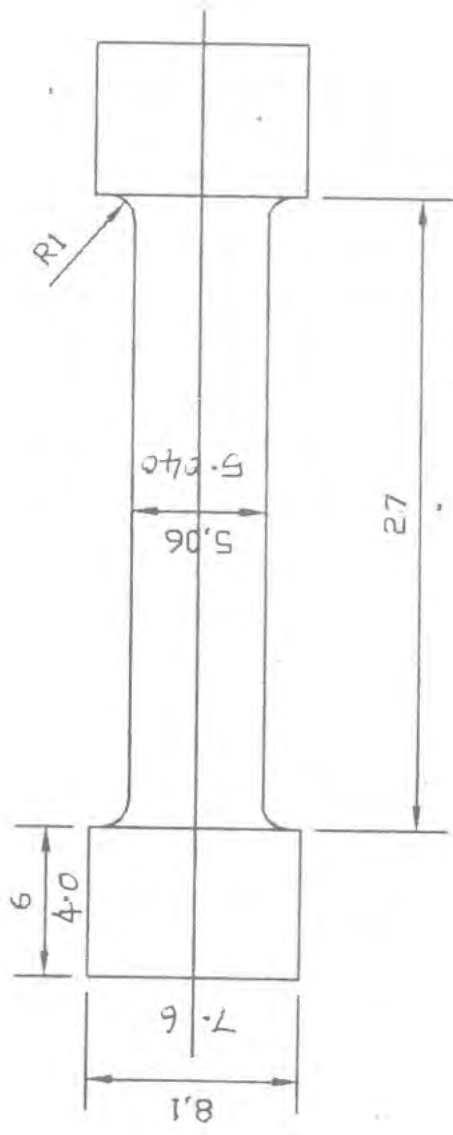

ALL DIMENSIONS ARE IN mm

*R. Vaideeswarar*

Dr. R. VAIDEESWARAN,

Manager

Plant Lab / Quality

BHEL., Trichy - 620 014