

**Bharat Heavy Electricals Ltd**  
Electronics Division  
Mysore Road, Bangalore – 560026

**ADDENDUM TO RFQ No: HBSBOS005 (SUPPLY OF  
STRING MONITORING UNIT (SMU) WITH RESPECT TO  
EXTENSION OF DUE DATE**

**TECHNICAL BID OPENING DATE: 01.09.2014 (MONDAY), 13:00 Hrs.**

Rest all the Terms & Conditions of the RFQ remains same.

This Tender Document Contains:  
General Terms and Conditions, Technical Specification, Unpriced Bid Formats & Price  
Bid Formats

Note: Part – I: **To be submitted in a separate sealed cover**

Part – II: **To be submitted in a separate sealed cover.**

And Part-I & Part-II sealed covers should be put in outer envelope and super scribing the Name of work and Name & Address of the tenderer. Tender document should be dropped in Tender drop box super scribed “**SC&PV-MM, Monday**” kept in reception area of

BHEL – EDN, Bangalore.

**Contact Person at BHEL:**

- 1. Mr. H.B. Srinivasa : Sr.Manager (SC&PV-MM)**  
**Ph.: 080-26988495, Mob: 09449869655**  
**Email:srinivasahb@bheledn.co.in**
- 2. Ms. Mrinalini Gupta: Sr. Engineer (SC&PV-MM)**  
**Ph.: 080-26998198**  
**Email:mrinalinigupta@bheledn.co.in**

# REQUEST FOR QUOTATION

	<b>BHARAT HEAVY ELECTRICALS LIMITED</b> Electronics Division PB No. 2606, Mysore Road Bangalore - 560026 INDIA	RFQ NUMBER: <b>HBSBOS005</b>  RFQ DATE : 26.JUL.2014	Due Date <b>29.AUG.2014</b> Time: <b>13:00 HRS</b>  VENUE : <b>NEW ENGG. BLDG</b>
MMI:PU:RF:003			

	(for all correspondence) Purchase Executive : SRINIVAS H B Phone : 26998452 Fax : 00918026989217 E-mail: srinivasahb@bheledn.co.in
--	--

Please submit your lowest quotation subject to our terms and conditions attached for the material mentioned below. The quotation must be enclosed in a sealed envelope / Fax superscribed with RFQ no. and due date, should reach us on or before the due date by **13.00** hours IST and will be opened on the same day at **13.30** hours at the venue mentioned above. **PLEASE DROP THE OFFER IN THE BOX PROVIDED AT RECEPTION.**

**RFQ TERMS & CONDITIONS:**

1. Offer shall be submitted in two part :  
 Part 1 : Techno-Commercial Bid  
 Part 2 : Price Bid
2. This RFQ document comprises of :
  - (1) Request For Quotation
  - (2) Technical Specifications : PS- 439-883
  - (3) Enclosures B,B1&B2 : Commercial Terms & Conditions, Unpriced Bid Format and Price Bid Format
  - (4) General Terms and Conditions (Doc Ref : SCPV/BOS/01-Rev 01)
3. The delivery date indicated in RFQ is tentative. The actual delivery date shall be as indicated in Annexure B.

SI No.	Description	Qty	Unit	Delivery qty	Delivery Date
1	PS0679039007 String Monitoring Unit (SMU)-16 in 1 out As per specs.PS-439-883 Test Certificate	259	NO	114	08.MAR.2015
				19	13.DEC.2014
				41	14.OCT.2014
				36	09.DEC.2014
				36	30.SEP.2014
2	PS0679039309 Fuse link-15 A for SMB- OPCL As per specs.PS-439-883 Test Certificate	230	NO	13	17.SEP.2014
3	PS0679039309 Fuse link-15 A for SMB - KPCL As per specs.PS-439-883 Test Certificate	200	NO		
4	PS0679039309 Fuse link-15 A for SMB-Daman As per specs.PS-439-883 Test Certificate	100	NO		
5	PS0679039309 Fuse link-15 A for SMB- Diu As per specs.PS-439-883 Test Certificate	80	NO		
6	PS0679039309 Fuse link-15 A for SMB-DNH As per specs.PS-439-883 Test Certificate	50	NO		
7	PS0679039309 Fuse link-15 A for SMB- RC Puram As per specs.PS-439-883 Test Certificate	20	NO	30	14.OCT.2014
				100	08.MAR.2015
				20	07.OCT.2014
				30	07.OCT.2014
				30	09.DEC.2014
8	PS0679039317 Fuse holder for SMB-Daman	230	NO	20	13.DEC.2014

For and On behalf of BHEL.  Page 1 OF 3
---

# REQUEST FOR QUOTATION

	<b>BHARAT HEAVY ELECTRICALS LIMITED</b> Electronics Division PB No. 2606, Mysore Road Bangalore - 560026 INDIA	RFQ NUMBER: <b>HBSBOS005</b>  RFQ DATE : 26.JUL.2014	<b>Due Date</b> <b>29.AUG.2014</b> <b>Time: 13:00 HRS</b>  VENUE : <b>NEW ENGG. BLDG</b>
MMI:PU:RF:003			

	(for all correspondence) Purchase Executive : SRINIVAS H B Phone : 26998452 Fax : 00918026989217 E-mail: srinivasahb@bheledn.co.in
--	--

Please submit your lowest quotation subject to our terms and conditions attached for the material mentioned below. The quotation must be enclosed in a sealed envelope / Fax superscribed with RFQ no. and due date, should reach us on or before the due date by **13.00** hours IST and will be opened on the same day at **13.30** hours at the venue mentioned above. **PLEASE DROP THE OFFER IN THE BOX PROVIDED AT RECEPTION.**

SI No.	Description	Qty	Unit	Delivery qty	Delivery Date
8	As per specs.PS-439-883 Test Certificate				
9	PS0679039317 Fuse holder for SMB-DNH As per specs.PS-439-883 Test Certificate	210	NO		
10	PS0679039317 Fuse holder for SMB - KPCL As per specs.PS-439-883 Test Certificate	180	NO		
11	PS0679039317 Fuse holder for SMB - RC Puram As per specs.PS-439-883 Test Certificate	80	NO		
12	PS0679039317 Fuse holder for SMB-OPCL As per specs.PS-439-883 Test Certificate	60	NO		
13	PS0679039317 Fuse holder for SMB-Diu As per specs.PS-439-883 Test Certificate	30	NO	30 30 20 100 30 20	07.OCT.2014 14.OCT.2014 13.DEC.2014 08.MAR.2015 09.DEC.2014 07.OCT.2014
14	PS0679039325 DC SPD 1000 V for SMB-Diu As per specs.PS-439-883 Test Certificate	17	NO		
15	PS0679039325 DC SPD 1000 V for SMB-OPCL As per specs.PS-439-883 Test Certificate	14	NO		
16	PS0679039325 DC SPD 1000 V for SMB - KPCL As per specs.PS-439-883 Test Certificate	11	NO		
17	PS0679039325 DC SPD 1000 V for SMB - RC Puram As per specs.PS-439-883 Test Certificate	7	NO		
18	PS0679039325 DC SPD 1000 V for SMB-Daman As per specs.PS-439-883 Test Certificate	5	NO		
19	PS0679039325 DC SPD 1000 V for SMB-DNH As per specs.PS-439-883 Test Certificate	3	NO	3 2 2 4 3 3	09.DEC.2014 07.OCT.2014 13.DEC.2014 09.MAR.2015 14.OCT.2014 07.OCT.2014

For and On behalf of BHEL.

Page 2 OF 3

# REQUEST FOR QUOTATION

	<b>BHARAT HEAVY ELECTRICALS LIMITED</b> Electronics Division PB No. 2606, Mysore Road Bangalore - 560026 INDIA	<b>RFQ NUMBER:</b> HBSBOS005  <b>RFQ DATE :</b> 26.JUL.2014	<b>Due Date</b> <b>29.AUG.2014</b> <b>Time: 13:00 HRS</b>  <b>VENUE :</b> <b>NEW ENGG. BLDG</b>
MMI:PU:RF:003			(for all correspondence) Purchase Executive : SRINIVAS H B Phone : 26998452 Fax : 00918026989217 E-mail: srinivasahb@bheledn.co.in
Please submit your lowest quotation subject to our terms and conditions attached for the material mentioned below. The quotation must be enclosed in a sealed envelope / Fax superscribed with RFQ no.and due date, should reach us on or before the due date by <b>13.00</b> hours IST and will be opened on the same day at <b>13.30</b> hours at the venue mentioned above. <b>PLEASE DROP THE OFFER IN THE BOX PROVIDED AT RECEPTION.</b>			
<b>Total Number of Items - 19</b>			
Please note that the tender will be opened in the presence of the bidders or his authorised representatives (maximum two per organisation) who choose to be present with authorisation letters. Refer annexure for the terms and conditions. Preference will be given to vendors who accepts our standard payment terms i.e.100% payment - 30 days after receipt of material at our works subject to acceptance. Please specify Terms of delivery, Excise duty, sales tax, Ex-BHEL, Ex-works surcharge, Insurance,P&F, Freight and other taxes very clearly . For evaluation,exchange rate(TT selling rate of SBI) as on scheduled date of tender opening (Part-I bid incase of two part bid) shall be considered. The offers of the bidders who are on the banned list as also the offer of the bidders, who engage the services of the banned firms, shall be rejected.The list of banned firms is available on BHEL web site <a href="http://www.bhel.com">www.bhel.com</a>			
i). This is only RFQ not an order. ii). In all correspondence quote RFQ No. & due date. iii). In Quotation BHEL material code / RFQ Sl. No. should be mentioned clearly. iv). Quotation Envelope / Fax not superscribed with RFQ No.and due date is liable for rejection. v). Quotation should remain valid for a minimum peiod of 90 days from due date. vi). In case of non-receipt of Quotation or regret letter for 3 consecutive RFQs you are liable to be removed from our vendors list. vii). All Prices should be written in words and numbers. viii). Excise Chapter Heading should be mentioned for all items where VAT is applicable .			

For and On behalf of BHEL.



	<b>SUPPLY OF STRING MONITORING BOXES</b>	PS-439-883
		REV NO: 00
		PAGE : 1 OF 6

**COPY RIGHT AND CONFIDENTIAL**

The information on this document is the property of Bharat Heavy Electricals Limited.

It must not be used directly or indirectly in anyway detrimental to the interest to the company

**Technical specification**  
**For**  
**Supply of**  
**String Monitoring Boxes**

Revision details :R 00	Prepared	Approved	Date
	 BKC/LNK	 SLR	26-06-2014

	<b>SUPPLY OF STRING MONITORING BOXES</b>	PS-439-883
		REV NO: 00
		PAGE : 2 OF 6

### 1.0 Pre-qualification criteria:

- 1.0.1 Vendor shall ensure that the SMBs are manufactured in INDIA and should have manufacturing capacity of at least 150 nos. of SMBs/month. **Vendor acceptance (Yes / No).**
- 1.0.2 Vendor should have supplied SMBs for: **Vendor acceptance (Yes / No).**
- A. A minimum cumulative of 10MWp SPV power plant projects in India during the last 3 years.
- B. At least one power plant project of 1 MW and above.
- Evidence shall be furnished in the form of completion certificates from end users along with copies of purchase orders.

**REFER ANNEXURE-1 ATTACHED WITH THIS SPECIFICATION FOR PROJECT DETAILS AND SCOPE OF SUPPLY.**

### 2.0 Technical specification of String Monitoring Box:

Offer shall be submitted by vendor with clause-wise acceptance as shown below with signature and seal on every page.

Incase of conflict between this specification and those (IS: Codes, standards etc) referred to herein, the former shall prevail. If the vendors acceptance is 'NO' against any of the clauses mentioned herein, the offer is liable for rejection on technical grounds. Incase of any deviations, vendor to record the same in the column meant for vendor compliance.

**Vendor acceptance (Yes / No).**

#### 2.1 Supply of string monitoring box: 16-in, 1-out

#	BHEL specification	Vendor compliance (Yes / No)
2.1.1	String monitoring box with 16-in,1-out combiner type, degree of protection of IP65 or better, complete with following items:	
2.1.2	The enclosure shall be Flammability Fire Retardant with Self-Extinguishing property and free from Halogen. It should be UV resistant in accordance with UL 746C suitable for outdoor application. The mechanical impact resistance of IK 07 or better as per IEC 62262 or equivalent standard. All enclosures shall be provided with transparent lids.	
2.1.3	Positive side and negative side fuses (15A) to be mounted on fuse holders. Fuse failure indication for the positive side fuses only shall be provided. Datasheet along with make shall be submitted along with the bid.	
2.1.4	250A (minimum), 1000V isolator that will be used to disconnect both positive and negative sides simultaneously.	
2.1.5	Surge protection device (SPD): surge arrestor type II, 1000V DC. Datasheet along with make shall be submitted along with the bid.	

	<b>SUPPLY OF STRING MONITORING BOXES</b>	PS-439-883
		REV NO: 00
		PAGE : 3 OF 6

#	BHEL specification	Vendor compliance (Yes / No)
2.1.6	<p>String monitoring, processing &amp; controller system for sensing and processing the string / box parameters viz.</p> <p>(a) Analog signals:</p> <ol style="list-style-type: none"> <li>String currents: 16 strings of 10A DC max each (two strings shall be combined for sensing current. This combining of strings shall be done only after the respective fuse(s).Hence current sensing of 8 channels is envisaged).</li> <li>Box voltage: 1000V DC max</li> <li>Box temperature</li> <li>SPV module temperature</li> </ol> <p>(b) Digital signals:</p> <ol style="list-style-type: none"> <li>Isolator ON/OFF status</li> <li>SPD status</li> </ol>	
2.1.7	<p>Either shunt-based (or) CT/hall-effect sensor (LEM)-based mechanism(Vendor shall indicate the proposed mechanism) shall be employed for sensing string currents together with</p> <ol style="list-style-type: none"> <li>Analog to digital converters for converting above current, voltage and temperature signals</li> <li>CPU / Microcontroller for data processing and control</li> <li>Any other accessories such as PLCs, interface cards / modules as applicable to the specific design</li> <li>RS-485 MODBUS-RTU communication interface</li> </ol>	
2.1.8	<p>Internal DC-DC converter based power supply. DC power shall be drawn from solar array output. No auxiliary AC supply shall be made available to the SMB's.</p>	
2.1.9	<p>RTD type (Pt100) or Semiconductor type temperature sensor for box temperature of every box. Arrangement for ventilation without sacrificing IP Rating shall be provided. Details in this regard to be furnished along with the bid.</p>	
2.1.10	<p>One of the combiner boxes shall be supplied with a module temperature sensor (Pt100, adhesive based) that shall be fixed on the backside of the SPV module. Necessary cables, fixing arrangements, etc shall be included in scope of supply.</p>	
2.1.11	<p>Bus bars: Tinned copper bus bars shall be employed. Output DC power cable termination shall be on to a 50x5mm tinned copper strip.</p>	

	<b>SUPPLY OF STRING MONITORING BOXES</b>	PS-439-883
		REV NO: 00
		PAGE : 4 OF 6

#	BHEL specification	Vendor compliance (Yes / No)
2.1.12	Terminal blocks Quantity as required.	
2.1.13	Interconnecting cables (PVC insulated copper, fire resistant)	
2.1.14	MC4 female connectors to be provided in the SMB box to connect the incoming string cables (6 sq mm) from PV array.	
2.1.15	Cable glands of thermoplastic polyamide and appropriate size to match the outgoing cables of BHEL scope: 1C X 185/240-sq-mm each for positive and negative, Al conductor, armoured, PVC sheath as per IS:1554(PART-1).	
2.1.16	All cable glands shall be located on the bottom side of the box to prevent any possibility of water ingress into the box.	
2.1.17	All metallic hardware such as nuts, bolts, screws, washers etc shall be of SS304 and appropriate size. Spring washers shall be zinc/epoxy coated.	
2.1.18	Cable lugs, ferrules, cable ties etc required for connecting the communication cables to the combiner boxes shall be in vendor scope. Note: supply of communication cables, as advised by vendor, will be in BHEL scope.	
2.1.19	Necessary earthing provisions and terminations.	
2.1.20	Commissioning support at site during commissioning of system and SCADA shall be provided by the vendor for all the various site(s) as indicated in the enclosed ANNEXURE-1.	
2.1.21	Danger sign with skull mark and 1000 volts indication in bold RED should be provided at clearly visible location on each SMB.	
2.1.22	Vendor shall supply mounting structure as indicated in the enclosed drawing 3-679-05-00712 for fixing complete set of string monitoring boxes in solar field. This shall be a ground mounted arrangement to mount the boxes on separate concrete pedestal. <ul style="list-style-type: none"> <li>(a) All the components including the hardware that are required for mounting shall be included in the scope of supply.</li> <li>(b) All hardware (nuts, bolts, washers etc) shall be SS304.Spring washers shall be with Zn/epoxy coated.</li> </ul>	
2.1.23	Any other additional accessories as may be considered relevant and applicable for the operation and mounting of string monitoring (combiner) boxes shall be included in the scope and brought out in the offer.	
2.1.24	During the warranty period, whenever a technical problem is encountered, BHEL shall report the same to the vendor. Vendor must ensure that the problem is attended to within TWO days from the date of reporting either by	

	<b>SUPPLY OF STRING MONITORING BOXES</b>	PS-439-883
		REV NO: 00
		PAGE : 5 OF 6

	replacement or repair of the defective part(s) free of cost to BHEL. Charges incurred by the vendor towards travel, lodging, boarding and any other contingency expenditure shall be deemed included in the cost of equipment .	
--	---	--

**Note:** Wherever make is not specified in this Purchase Specification, vendor shall obtain prior BHEL approval.

### 3.0 Testing and inspection

#	BHEL specification	Vendor compliance (Yes / No)
3.1	<p><b>Routine tests</b>, as per relevant standards (IS, IEC etc), shall be carried out on the string monitoring (combiner) box and all the tests shall be witnessed by BHEL. Vendor shall submit manufacturing quality plan, indicating relevant IS/IEC standards within one week of placement of order for BHEL approval. Following shall be the minimum checks.</p> <ol style="list-style-type: none"> <li>1. Visual inspection check</li> <li>2. Bill of materials check</li> <li>3. Electrical continuity check</li> <li>4. HV insulation tests</li> <li>5. Functional checks</li> </ol> <p>Test reports shall be submitted prior to dispatch of the system to the site.</p>	
3.2	<p><b>Test certificates / calibration certificates</b> shall be submitted for following:</p> <ol style="list-style-type: none"> <li>1. String monitoring combiner boxes</li> <li>2. Current sensing board</li> </ol>	

	<b>SUPPLY OF STRING MONITORING BOXES</b>	PS-439-883
		REV NO: 00
		PAGE : 6 OF 6

#### 4.0 Documents to be submitted after receipt of purchase order

#	BHEL specification	Vendor compliance (Yes / No)
4.1	<p>Following documents shall be submitted within 7 days from the date of purchase order for BHEL approval.</p> <ol style="list-style-type: none"> <li>1. General Arrangement of string monitoring (combiner) box, with detailed dimensions, bill of materials, make / part number / rating / quantity of individual components, overall weight, applicable standards.</li> <li>2. Drawing of ground-mounted scheme for string monitoring (combiner) box with details of fixtures and hardware.</li> <li>3. Product catalogues / datasheets of string monitoring combiner boxes, enclosures of combiner boxes, isolator , surge protection device, controller cards, DC-DC converter, signal cables etc.</li> <li>4. List of all communication cables with make, type and specifications.</li> <li>5. Manufacturing Quality Plan for the String Monitoring Box.</li> </ol>	

#### 5.0 Documents to be submitted along with consignment

#	BHEL specification	Vendor compliance (Yes / No)
5.1	<p>Following documents shall be submitted at the time of dispatch:</p> <ol style="list-style-type: none"> <li>1. Test reports on string monitoring combiner boxes.</li> <li>2. Operation and maintenance manual for string monitoring combiner box.</li> </ol>	

	<b>SUPPLY OF STRING MONITORING BOXES</b>	REV NO: 00
		PAGE : 1 OF 2

**ANNEXURE: 1**

*Ref: BHEL/SCPV/COMMONPURCHASE/SMU/01*

**Introduction**

**DATE:05/07/2014**

Bharat Heavy Electricals Limited (BHEL), Electronics Division, Bangalore is setting up Grid-connected SPV Power Plants at

- A) DIU (3 MW).
- B) DAMAN (1 MW).
- C) OPCL (3.42 MW).
- D) DADRA AND NAGAR HAVELI-DNH (3 MW).
- E) KPCL, MANDYA, KARNATAKA (10 MW).
- F) BHEL –RC PURAM, HYDERABAD (1.5 MW).

This technical specification provides BHEL requirements for supply of string monitoring boxes (16-in, 1-out combiner boxes) for the above Solar PV Plants.

**1.0 Scope of supply**

SL No	Item Description	QUANTITY					
		KPCL	DAMAN	DIU	OPCL	DNH	BHEL RC PURAM
1.1	Supply of string monitoring (combiner) box, 16-input, 1-output (including spares), complete with CPU/microcontroller card and other necessary components as per clause 2.0 of purchase specification PS-439-883.	114 sets	13 sets	36 sets	41 sets	36 sets	19 sets
1.2	Supply of other spare items for string monitoring (combiner) box as below:						
	Fuse	100 nos	20 nos	30 nos	30 nos	30 nos	20 nos

	<b>SUPPLY OF STRING MONITORING BOXES</b>	REV NO: 00
		PAGE : 2 OF 2

		KPCL	DAMAN	DIU	OPCL	DNH	BHEL RC PURAM
	Fuse box (holder)	100 nos	20 nos	30 nos	30 nos	30 nos	20 nos
	SPD	4 nos	2 nos	3 nos	3 nos	3 nos	2 nos

FIRST ANGLE PROJECTION  
21000-50-649-3

PRODUCED BY AN AUTODESK EDUCATIONAL PRODUCT

(ALL DIMENSIONS ARE IN mm)

THE INFORMATION ON THIS DOCUMENT IS THE PROPERTY OF BHARAT HEAVY ELECTRICALS LTD. IT MUST NOT BE USED DIRECTLY OR INDIRECTLY IN ANY WAY DETRIMENTAL TO THE INTEREST OF THE COMPANY.

FLYER NO. A3-03

PRODUCED BY AN AUTODESK EDUCATIONAL PRODUCT

A3 SIZE

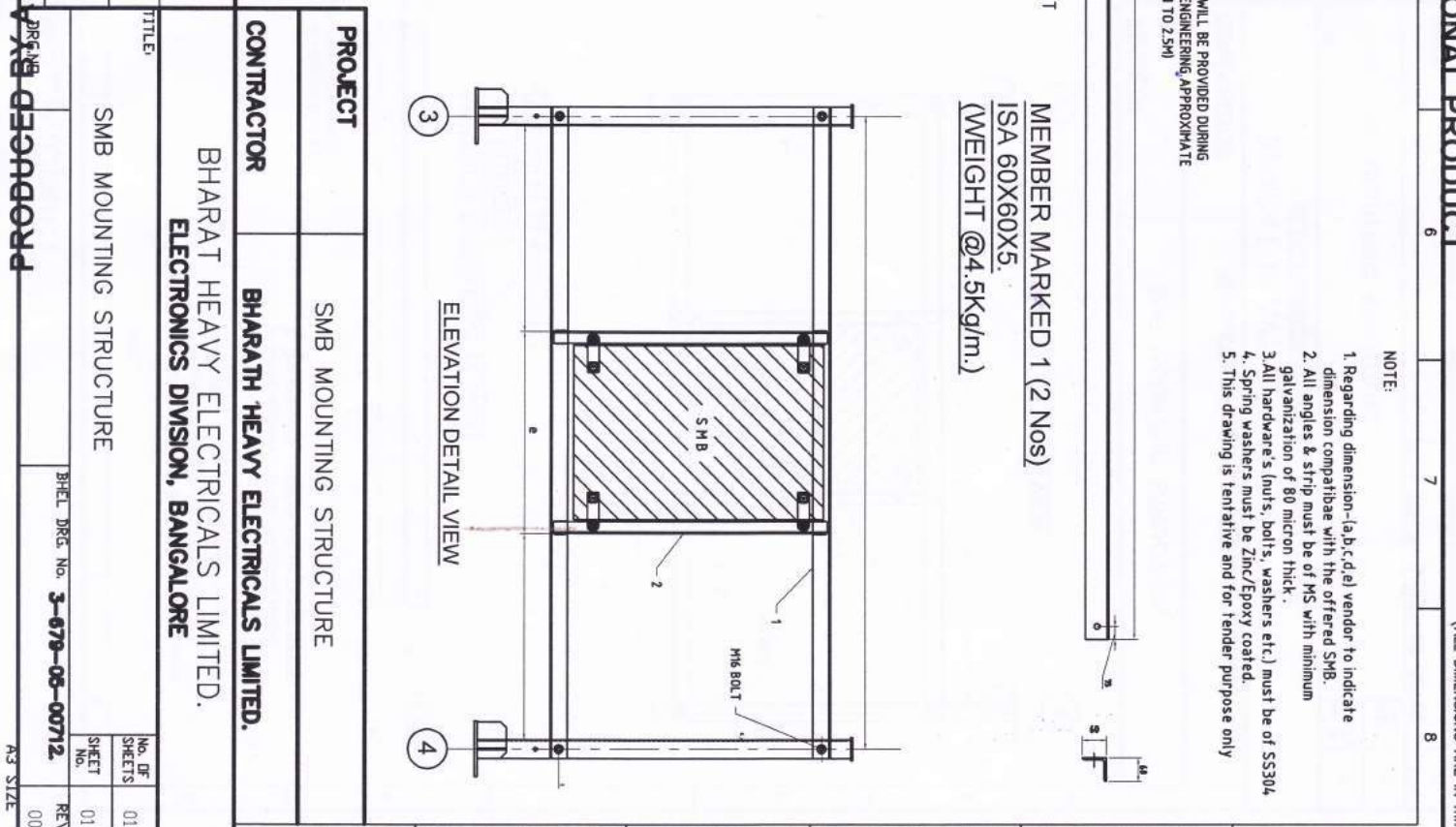
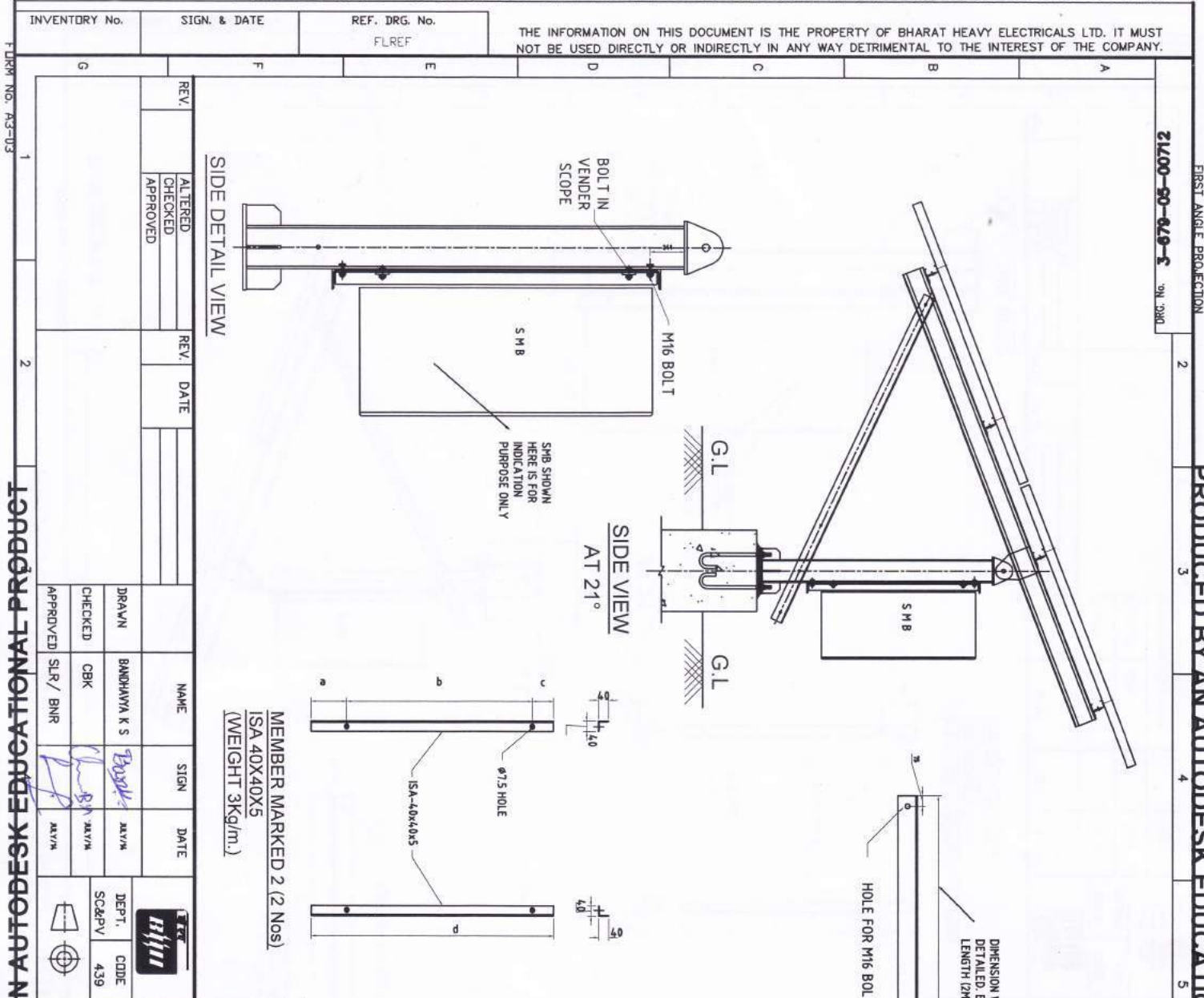

INVENTORY No.	SIGN. & DATE	REF. DRG. No.	FLREF			
REV.	ALTERED	REV.	DATE	NAME	SIGN	DATE
	CHECKED			BANDHANA K S	<i>[Signature]</i>	
	APPROVED			CBK	<i>[Signature]</i>	
				SR / BNR	<i>[Signature]</i>	
				AYVA	<i>[Signature]</i>	
				DEPT. SC&PV	CODE	
					439	

<b>PROJECT</b>	SMB MOUNTING STRUCTURE
<b>CONTRACTOR</b>	BHARATH HEAVY ELECTRICALS LIMITED.
	BHARAT HEAVY ELECTRICALS LIMITED.
	ELECTRONICS DIVISION, BANGALORE.
<b>TITLE:</b>	SMB MOUNTING STRUCTURE
<b>SHEET DRG. No.</b>	3-679-05-00712
<b>No. OF SHEETS</b>	01
<b>SHEET NO.</b>	01
<b>REV</b>	00

- NOTE:
1. Regarding dimension-(a,b,c,d,e) vendor to indicate dimension compatible with the offered SMB.
  2. All angles & strip must be of MS with minimum galvanization of 80 micron thick.
  3. All hardware's (nuts, bolts, washers etc.) must be of SS304.
  4. Spring washers must be Zinc/Epoxy coated.
  5. This drawing is tentative and for tender purpose only.

DIMENSION WILL BE PROVIDED DURING DETAILED ENGINEERING APPROXIMATE LENGTH (2M TO 2.5M)

MEMBER MARKED 1 (2 Nos)  
ISA 60X60X5.  
(WEIGHT @4.5Kg/m.)

SIDE DETAIL VIEW

SIDE VIEW AT 21°

ELEVATION DETAIL VIEW

COMMERCIAL TERMS & CONDITIONS				
RFQ No.HBBOS005 DATED : 26.07.2014 DUE DATE(TECH BID) : 29.08.2014				
Sl No.	Terms	BHEL Term	Confirmation	Deviation / Remarks
1	Bidding	(a) Bid has to be submitted as Two Part – in two sealed covers-Techno Commercial Bid(Part-1) & Price Bid (Part-II)- clearly written on each cover both put in a single sealed envelope super-scribed with RFQ No. and Due date.	Agree / Not agree	
		(b) Annexures B & B1 to be submitted along with technical bid (Part-1) & Annexure B2 to be submitted along with Price bid (Part-II).	Agree / Not agree	
		(c) Clause-wise compliance to BHEL Purchase specification along with all documents as called in Technical specification to be submitted along with technical bid(Part-1).	Agree / Not agree	
2	Price Basis	Firm i.e., from the date of PO to completion of supply if I&C is not applicable. If I&C is in supplier's scope, then the prices shall remain Firm till commissioning & handing-over of the complete system. (PVC clause not acceptable).	Agree / Not agree	
3	Terms of Delivery	Free On Road Basis to Respective sites	Agree / Not agree	
4	Delivery Period	(a) Supply : 6 Weeks from the Sample Approval; Drawing Submission: 1 week from PO Date; Sample Submission for Inspection: 1 Week from Drawing approval	Agree / Not agree	
5	Payment Term	(a)Supply : 90% payment of Supply Value + 100% Taxes shall be made with 45 days credit from the date of receipt of material at site. Balance 10% on execution of PBG valid for warranty period + 6 months claim period from any of the BHEL Consortium banks.	Agree / Not agree	
		(b) For any deviation in payment term, the offer will be liable for loading as per Clause 25A(ii) of Enquiry-General Terms & conditions (Doc Ref : SCPV/BOS/01-Rev 00)	Agree / Not agree	
6	Excise Duty	(a) To confirm whether applicable. If applicable, indicate prevailing rate of Excise duty.	Applicable / Not applicable	Prevailing rate of Excise duty : ..... %
		(b) BHEL is trying to avail Customs Duty & Excise duty exemption. Successful bidder shall support with all relevant documents.	Agree / Not agree	
7	Sales Tax	(a) To confirm whether applicable. If applicable, indicate prevailing rate of Sales Tax against Form C.	Applicable / Not applicable	Prevailing rate of Sales Tax : ..... %
		(b) For issue of form "C", vendor has to furnish "E1/E2" form. Please confirm that "E1/E2 Sale form" will be submitted.	Agree / Not agree	
8	Value Added Tax	Since it is inter-state movement of goods, VAT is not applicable. Only CST against form C is applicable	Applicable / Not applicable	
		OR Both are in the same State, VAT is applicable please indicate VAT applicable.	Applicable / Not applicable	Prevailing rate of VAT : ..... %
9	Octroi	To confirm whether applicable, if applicable indicate current rate of Octroi.	Applicable / Not applicable	Octroi_____%

AUTHORISED SIGNATORY WITH SEAL

COMMERCIAL TERMS & CONDITIONS				
RFQ No.HBBOS005 DATED : 26.07.2014 DUE DATE(TECH BID) : 29.08.2014				
Sl No.	Terms	BHEL Term	Confirmation	Deviation / Remarks
10	Service Tax	To confirm whether applicable, if applicable indicate current rate of Service Tax.	Applicable / Not applicable	Prevailing rate of Service Tax ..... %
		Furnish following : Service Tax Regn. No. Confirmation that Service Tax register is maintained.	Applicable / Not applicable	Service Tax Regn. No.....
11	Freight	If Freight is quoted extra, original money receipt from Transporter has to be submitted for payment of freight. Please indicate a lumpsum value for Freight charges in Price bid if quoted extra.	Agree / Not agree	
12	Insurance	Transit Insurance will be in vendor's scope.	Agree / Not agree	
13	Evaluation of L1 vendor	Over all L1 of Supply on "FOR" basis to site will only be considered.	Agree / Not agree	
14	Warranty	Warranty for Supply : 42 months from date of supply or 36 months from I&C whichever is earlier	Agree / Not agree	
15	Pre Shipment Inspection	Pre Shipment Inspection will be carried out by BHEL/Customer for which test report shall be sent one week in advance.	Agree / Not agree	
16	Penalty	(a) Penalty of 0.5% per week at the basic price of the good for undelivered quantity of supply portion, subject to a maximum of 10%. For Supply, Pre Shipment Inspection Call Letter Date (Receipt of test report) will be treated as delivery for purpose of penalty.	Agree / Not agree	
		( b )For any deviation in penalty term, the offer will be liable for loading as per Clause 25.B of Enquiry-General Terms & conditions (Doc Ref : SCPV/BOS/01-Rev 00)	Agree / Not agree	
17	Road Permit	Road permit if applicable will be given by BHEL before Dispatch of ordered Items	BHEL	
18	Despatch Documents	Complete set of despatch documents in 3 sets shall be forwarded to BHEL directly. Despatch documents include Commercial Invoice, Excise Invoice (if ED is applicable), Lorry receipt (L/R), Packing list, Warranty certificate, Insurance intimation letter, & Original Performance Bank Guarantee (Directly from issuing bank to BHEL). One set of Invoice, Packing list and L/R shall be faxed immediately after despatch to BHEL-EDN, Bangalore.	Agree / Not agree	
19	Other terms & conditions	For any other Terms and Conditions, kindly refer to the enclosed Enquiry-General Terms & Conditions of BHEL (Doc Ref : SCPV/BOS/01-Rev 00)	Agree / Not agree	
20	Reverse Auction	BHEL reserves the right to conduct Reverse Auction. Procedure for the same will be informed by BHEL .	Agree / Not agree	
21	Annexure	Technical Specification- PS-439-883 & Annexure-1 Ref: BHEL/SCPV/COMMONPURCHASE/SMU/01 dated 05.07.2014	Read & Noted	
22	Shipment	Kindly indicate the state from where the shipment will take place	State/Place	

For R C PURAM, HYDERABAD:Two options shall be quoted with respect to Taxation only:

1. BHEL EDN, Bangalore will release formal Purchase Order & arrange payment with Non-concessional CST(VAT of Material Originating State.)
2. BHEL EDN, Bangalore will issue Letter of Intent(LOI) & BHEL RC Puram, Hyderabad will release formal PO & arrange payment with 2% CST against Form C.

AUTHORISED SIGNATORY WITH SEAL

TECHNICAL BID ENCLOSURE FOR COMPLIANCE OF QUOTE															
RFQ No.HBBS005 DATED : 26.07.2014 DUE DATE(TECH BID) : 29.08.2014															
SI No.	DESCRIPTION	QUOTED	CONTRACT						UNIT	SITE	TAXES				Remarks
			KPCL	DIU	OPCL	DAMAN	RC PURAM	DADAR AND HAVELLI			ED %	CST%	VAT %	SERVICE TAX %	
1	PS0679039007: Supply for SMB-16 in 1 out as per Tech Spec-PS-439-883 Ref: BHEL/SCP/COMMONPURCHASE/SMU/01 dated 05.07.2014	YES/NO	114	36	41	13	19	36	NO.	KPCL				NA	Taxes Extra
										DIU				NA	
										OPCL				NA	
										DAMAN				NA	
										RC PURAM				NA	
										DNH				NA	
2	PS0679039309:Supply of Fuse Link-15 A for SMB as per Tech Spec-PS-439-883 Ref: BHEL/SCP/COMMONPURCHASE/SMU/01 dated 05.07.2014	YES/NO	100	30	30	20	20	30	NO.	KPCL				NA	Taxes Extra
										DIU				NA	
										OPCL				NA	
										DAMAN				NA	
										RC PURAM				NA	
										DNH				NA	
3	PS0679039317: Fuse holders for SMB as per BHEL Spec PS-439-883 Ref: BHEL/SCP/COMMONPURCHASE/SMU/01 dated 05.07.2014	YES/NO	100	30	30	20	20	30	NO.	KPCL				NA	Taxes Extra
										DIU				NA	
										OPCL				NA	
										DAMAN				NA	
										RC PURAM				NA	
										DNH				NA	
4	PS0679039325: DC SPDs 1000V for SMB as per BHEL Spec PS-439-883 Ref: BHEL/SCP/COMMONPURCHASE/SMU/01 dated 05.07.2014	YES/NO	4	3	3	2	2	3	NO.	KPCL				NA	Taxes Extra
										DIU				NA	
										OPCL				NA	
										DAMAN				NA	
										RC PURAM				NA	
										DNH				NA	
<b>Total of the above</b>															
5	**Freight Charge including Service Tax on Freight(12.36% on 25% of Freight Value)	YES/NO									NA	NA	NA	NA	Included/Extra
i.	KPCL	YES/NO									NA	NA	NA	NA	Included/Extra
ii.	DIU	YES/NO									NA	NA	NA	NA	Included/Extra
iii.	OPCL	YES/NO									NA	NA	NA	NA	Included/Extra
iv.	DIU	YES/NO									NA	NA	NA	NA	Included/Extra
v	RC PURAM	YES/NO									NA	NA	NA	NA	Included/Extra
vi.	DADAR & NAGAR HAVELLI	YES/NO									NA	NA	NA	NA	Included/Extra
6	**Insurance	YES/NO									NA	NA	NA	NA	Included/Extra
i.	KPCL	YES/NO									NA	NA	NA	NA	Included/Extra
ii.	DIU	YES/NO									NA	NA	NA	NA	Included/Extra
iii.	OPCL	YES/NO									NA	NA	NA	NA	Included/Extra
iv.	DIU	YES/NO									NA	NA	NA	NA	Included/Extra
v	RC PURAM	YES/NO									NA	NA	NA	NA	Included/Extra
vi.	DADAR & NAGAR HAVELLI	YES/NO									NA	NA	NA	NA	Included/Extra

**NOTE: ALL THE SMB'S WILL BE PROCURED FROM SINGLE VENDOR ONLY.**

1.YOUR QUOTED PRICES SHALL BE on "FREE ON ROAD" basis to RESPECTIVE SITE basis.

2.PL INDICATE TAXES : ED,VAT /CST,SERVICE TAX CLEARLY APPLICABLE AS ON DATE.

3.USE THIS FORMAT FOR COMPLIANCE( REPRODUCING ON YOUR LETTER HEAD IS ACCEPTABLE).

4. FOR SL NOS 1 - 4, TAXES WILL BE CONSIDERED EXTRA.PLEASE QUOTE ONLY THE BASIC RATES.

5.\*\*INDICATE WHETHER FREIGHT CHARGE &amp; INSURANCE CHARGE IS INCLUDED IN QUOTED RATE OR WILL BE CHARGED EXTRA.

IN ABSENCE OF CLARITY, QUOTED RATE WILL BE CONSIDERED AS INCLUSIVE OF FREIGHT &amp; INSURANCE CHARGES.(If the offer contains the Freight Value at actuals, it will be considered as All Inclusive).If Freight is quoted extra, original money receipt from Transporter has to be submitted for payment of freight.

6.BHEL IS TRYING TO GET CONCESSION ON EXCISE DUTY UNDER SUPPLY OF SOLAR POWER PROJECT.AT THE TIME OF CLEARANCE OF GOODS WE MAY ISSUE EXEMPTION CERTIFICATE.IN SUCH CASE, ED WILL BE EXEMPTED BUT NOT REIMBURSED. At present, please quote with applicable rate without concession of ED for comparison.

7. Overall L1 of all the sites (Supply+Freight+Insurance) will be considered. All the SMBs will be procured from one Vendor only.

8. For R C PURAM, HYDERABAD:Two options shall be quoted with respect to Taxation only:

1. BHEL EDN, Bangalore will release formal Purchase Order &amp; arrange payment with Non-concessional CST(VAT of Material Originating State.)

2. BHEL EDN, Bangalore will issue Letter of Intent(LOI) &amp; BHEL RC Puram, Hyderabad will release formal PO &amp; arrange payment with 2% CST against Form C.

AUTHORISED SIGNATORY WITH SEAL

PRICE BID ENCLOSURE FOR COMPLIANCE OF QUOTE																	
RFQ No.HBB05005 DATED: 26.07.2014 DUE DATE(TECH BID) : 29.08.2014																	
Sl No.	DESCRIPTION	QUOTED	CONTRACT						UNIT	SITE	UNIT RATE(Rs.)	TOTAL RATE(UNIT RATE*QTY)	TAXES				Remarks
			KPCL	DIU	OPCL	DAMAN	RC PURAM	DADAR AND HAVELI					ED %	CST%	VAT %	SERVICE TAX %	
1	PS0679039007: Supply for SMB-16 in 1 out as per Tech Spec-PS-439-883 Ref: BHEL/SCPV/COMMONPURCHASE/SMU/01 dated 05.07.2014	YES/NO	114	36	41	13	19	36	ST	KPCL						NA	Taxes Extra
										DIU						NA	
										OPCL						NA	
										DAMAN						NA	
										RC PURAM						NA	
										DNH						NA	
i.	For KPCL: Unit Rate in Words(Rs.)																
ii.	For DIU: Unit Rate in Words(Rs.)																
iii.	For OPCL: Unit Rate in Words(Rs.)																
iv.	For DAMAN: Unit Rate in Words(Rs.)																
v.	For RC PURAM: Unit Rate in Words(Rs.)																
vi.	For DNH: Unit Rate in Words(Rs.)																
2	PS0679039309:Supply of Fuse Link-15 A for SMB as per Tech Spec-PS-439-883 Ref: BHEL/SCPV/COMMONPURCHASE/SMU/01 dated 05.07.2014	YES/NO	100	30	30	20	20	30	ST	KPCL						NA	Taxes Extra
										DIU						NA	
										OPCL						NA	
										DAMAN						NA	
										RC PURAM						NA	
										DNH						NA	
i.	For KPCL: Unit Rate in Words(Rs.)																
ii.	For DIU: Unit Rate in Words(Rs.)																
iii.	For OPCL: Unit Rate in Words(Rs.)																
iv.	For DAMAN: Unit Rate in Words(Rs.)																
v.	For RC PURAM: Unit Rate in Words(Rs.)																
vi.	For DNH: Unit Rate in Words(Rs.)																
3	PS0679039317: Fuse holders for SMB as per BHEL Spec PS-439-883 Ref: BHEL/SCPV/COMMONPURCHASE/SMU/01 dated 05.07.2014	YES/NO	100	30	30	20	20	30	ST	KPCL						NA	Taxes Extra
										DIU						NA	
										OPCL						NA	
										DAMAN						NA	
										RC PURAM						NA	
										DNH						NA	
i.	For KPCL: Unit Rate in Words(Rs.)																
ii.	For DIU: Unit Rate in Words(Rs.)																
iii.	For OPCL: Unit Rate in Words(Rs.)																
iv.	For DAMAN: Unit Rate in Words(Rs.)																
v.	For RC PURAM: Unit Rate in Words(Rs.)																
vi.	For DNH: Unit Rate in Words(Rs.)																
4	PS0679039325: DC SPDs 1000V for SMB as per BHEL Spec PS-439-883 Ref: BHEL/SCPV/COMMONPURCHASE/SMU/01 dated 05.07.2014	YES/NO	4	3	3	2	2	3	ST	KPCL						NA	Taxes Extra
										DIU						NA	
										OPCL						NA	
										DAMAN						NA	
										RC PURAM						NA	
										DNH						NA	
i.	For KPCL: Unit Rate in Words(Rs.)																
ii.	For DIU: Unit Rate in Words(Rs.)																
iii.	For OPCL: Unit Rate in Words(Rs.)																
iv.	For DAMAN: Unit Rate in Words(Rs.)																
v.	For RC PURAM: Unit Rate in Words(Rs.)																
vi.	For DNH: Unit Rate in Words(Rs.)																
5	**Freight Charge including Service Tax on Freight(12.36% on 25% of Freight Value)	YES/NO	LUMPSSUM BASIS									NA	NA	NA	NA	Included/Extra	
i.	KPCL	YES/NO	Rs.										NA	NA	NA	NA	Included/Extra
	For KPCL: Unit Rate in Words(Rs.)																
ii.	DIU	YES/NO	Rs.										NA	NA	NA	NA	Included/Extra
	For DIU: Unit Rate in Words(Rs.)																
iii.	OPCL	YES/NO	Rs.										NA	NA	NA	NA	Included/Extra
	For OPCL: Unit Rate in Words(Rs.)																
iv.	DAMAN	YES/NO	Rs.										NA	NA	NA	NA	Included/Extra
	For DAMAN: Unit Rate in Words(Rs.)																
v.	RC PURAM	YES/NO	Rs.										NA	NA	NA	NA	Included/Extra
	For RC PURAM: Unit Rate in Words(Rs.)																
vi.	DADAR AND HAVELI	YES/NO	Rs.										NA	NA	NA	NA	Included/Extra
	For DNH: Unit Rate in Words(Rs.)																
6	**Insurance	YES/NO	LUMPSSUM BASIS									NA	NA	NA	NA	Included/Extra	
i.	KPCL	YES/NO	Rs.										NA	NA	NA	NA	Included/Extra
	For KPCL: Unit Rate in Words(Rs.)																
ii.	DIU	YES/NO	Rs.										NA	NA	NA	NA	Included/Extra
	For DIU: Unit Rate in Words(Rs.)																
iii.	OPCL	YES/NO	Rs.										NA	NA	NA	NA	Included/Extra
	For OPCL: Unit Rate in Words(Rs.)																
iv.	DAMAN	YES/NO	Rs.										NA	NA	NA	NA	Included/Extra
	For DAMAN: Unit Rate in Words(Rs.)																
v.	RC PURAM	YES/NO	Rs.										NA	NA	NA	NA	Included/Extra
	For RC PURAM: Unit Rate in Words(Rs.)																
vi.	DADAR AND HAVELI	YES/NO	Rs.										NA	NA	NA	NA	Included/Extra
	For DNH: Unit Rate in Words(Rs.)																

NOTE: ALL THE SMB'S WILL BE PROCURED FROM SINGLE VENDOR ONLY.

1.YOUR QUOTED PRICES SHALL BE ON "FREE ON ROAD" BASIS TO RESPECTIVE SITE BASIS.

2.PL INDICATE TAXES: ED,VAT/CST,SERVICE TAX CLEARLY APPLICABLE AS ON DATE.

3.USE THIS FORMAT FOR COMPLIANCE( REPRODUCING ON YOUR LETTER HEAD IS ACCEPTABLE).

4. FOR SL NOS 1-4, TAXES WILL BE CONSIDERED EXTRA.PLEASE QUOTE ONLY THE BASIC RATES.

5.\*\*INDICATE WHETHER FREIGHT CHARGE & INSURANCE CHARGE IS INCLUDED IN QUOTED RATE OR WILL BE CHARGED EXTRA.

IN ABSENCE OF CLARITY, QUOTED RATE WILL BE CONSIDERED AS INCLUSIVE OF FREIGHT & INSURANCE CHARGES.(IF THE OFFER CONTAINS THE Freight Value at actuals, it will be considered as All Inclusive). If Freight is quoted extra, original money receipt from Transporter has to be submitted for payment of freight.

6.BHEL IS TRYING TO GET CONCESSION ON EXCISE DUTY UNDER SUPPLY OF SOLAR POWER PROJECT.AT THE TIME OF CLEARANCE OF GOODS WE MAY ISSUE EXEMPTION CERTIFICATE.IN SUCH CASE, ED WILL BE EXEMPTED BUT NOT REIMBURSED. At present, please quote with applicable rate without concession of ED for comparison.

7. Overall L1 of all the sites (Supply+Freight+Insurance) will be considered. All the SMBs will be procured from one Vendor only.

8. For R C PURAM, HYDERABAD:Two options shall be quoted with respect to Taxation only:

1. BHEL EDN, Bangalore will release formal Purchase Order & arrange payment with Non-concessional CST(VAT of Material Originating State.)

2. BHEL EDN, Bangalore will issue Letter of Intent(LOI) & BHEL RC Puram, Hyderabad will release formal PO & arrange payment with 2% CST against Form C.

AUTHORISED SIGNATORY WITH SEAL

**Bharat Heavy Electricals Ltd.,**  
(A Government of India undertaking)  
**Electronics Division**  
PB No.2606, Mysore Road, Bangalore-560026, India

---

**Enquiry - General Terms & Conditions (Two part bid)**

**I. Enquiry / Request for Quotation (RFQ):**

- (a) Any Purchase Order resulting from this enquiry shall be governed by **these general terms and conditions listed below and special terms and conditions, if any, along with this enquiry** of Bharat Heavy Electricals Limited, Electronics Division, Bangalore-560026 (**hereinafter referred to as BHEL EDN**).
- (b) Any of the terms and conditions not acceptable to vendor, shall be explicitly mentioned in the quotation. Otherwise, it will be treated as that all terms and conditions of this enquiry are acceptable.
- (c) If counter terms and conditions are offered by vendor, BHEL EDN shall not be governed by such terms and conditions, unless it is agreed and incorporated in the Purchase Order of BHEL EDN.
- (d) Any deviation to the terms and conditions not mentioned in the quotation by vendor in response to this enquiry will not be considered, if put forth subsequently or after issue of order, unless clarification is sought for by BHEL EDN and agreed upon in the Purchase Order of BHEL EDN.
- (e) BHEL EDN reserves the right to adopt Reverse Auction for the enquiry sent, at its discretion.
- (f) BHEL EDN shall be at liberty to cancel the tender at any time, before ordering, without assigning any reason.
- (g) Any specific terms and conditions to be complied will be mentioned in RFQ.

**II. General Terms and conditions:**

1. **TWO PART BID:** Quotation shall be submitted in two part bid i.e.

**(a) Techno-commercial i.e., Un-priced Bid (in one sealed envelope):**

Techno-commercial bid shall be submitted with complete description of the equipment, specification compliances to the enquired specification and all the commercial terms & conditions indicated in the **COMMERCIAL TERMS (ANNEXURE-A for Foreign Purchase and ANNEXURE-B for Indigenous Purchase)**. Any other enclosure, which the vendor wishes to submit like product catalogue, technical literature etc., may also be submitted in a sealed envelope super scribed clearly as **"TECHNO-COMMERCIAL BID" with RFQ No. and DUE DATE**. An un-priced copy of price bid (without price) as per **ANNEXURE A-1 for Foreign Purchase and ANNEXURE B-1 for Indigenous Purchase** shall also be enclosed with the techno-commercial bid for evaluation of commercial terms. The vendor shall not give the price in the technical bid.

Confirmation to BHEL specifications shall be indicated by the vendor in the respective columns provided in the purchase specification wherever applicable. Deviations to the specification / item description, if any shall be brought out clearly indicating **"DEVIATION TO BHEL SPECIFICATION"** without fail as a part of technical offer.

Compliance to Pre-qualification criteria (if applicable) shall also be enclosed with the Techno-commercial bid.

Manufacturer's name, their trade mark and brand, part number, alternate material to the one asked in enquiry, if any, should be mentioned in quotation and illustrative leaflets giving technical particulars etc. are to be attached to facilitate consideration and technical evaluation of the quotation. BHEL EDN material code number (as in enquiry) shall be indicated for each item quoted.

**(b) Price Bid (in one sealed envelope):**

Price bid should contain basic unit prices, discount if any, applicable taxes & duties, packing & forwarding charges (if applicable), Freight & insurances (if applicable), FOB charge (if applicable) etc., in a sealed envelope super scribed clearly as **"PRICE BID" with RFQ No. and DUE DATE**.

It is preferred to indicate the rates in both figures and words. In such case, if there is a difference / discrepancy

**Signature of tenderer / with seal**  
**Page 1 of 12**

between the rates in figures and words, the **least of the two** rates will be considered. **Price bid shall be quoted as per ANNEXURE A-2 for Foreign Purchase and ANNEXURE B-2 for Indigenous Purchase.**

**(c) Tender Offer (above two envelopes inside another sealed envelope):**

Both these sealed envelopes [(a) Techno-commercial i.e., un-priced Bid and (b) Price Bid] shall be kept in a single sealed envelope and super scribed clearly with **RFQ No. and DUE DATE.**

2. The above sealed envelope (Tender) shall reach our office on or before the due date by 13:00 hrs. Quotations are to be dropped in the tender box marked for the OPENING ON respective days i.e., MONDAY / WEDNESDAY / FRIDAY kept at BHEL-EDN's Reception area of our works with caption "CE, SC & PV, DEFENCE". **Quotations also can be dispatched by Couriers / Registered post / FAX / e-mail to the Purchase Executive indicated in the RFQ at the risk of vendor / bidder.**

Quotation through courier / register post / fax / email when addressed to the specific fax number and email address given in the enquiry, to be sent well in advance to enable BHEL EDN purchase personnel to drop in the tender box before the scheduled opening date and time. Vendor is fully responsible for lack of secrecy on information of such quotations. Vendor shall confirm with the concerned purchase executive after sending the offer regarding such delivery mode to ensure participation. BHEL EDN is not responsible for any delay in receipt of quotation sent by vendor through post/fax/email.

Late Tenders i.e., Tenders received after due date & time will be rejected.

3. The rate quoted shall be in units stated in the enquiry. Where quotation is in terms of unit other than that in enquiry, relationship between the two units must be furnished in the quotation.
4. As far as possible, the quotations shall be free from corrections / overwriting. Corrections / overwriting, if any should be signed by authorized person with the company seal. Any typographical errors, totaling mistakes, currency mistakes, multiplication mistakes, summary mistakes observed in your priced bids, BHEL may consider whichever is beneficial to BHEL for evaluation. Vendor shall doubly ensure that the quote is correct and complete. The corrections / overwriting if any shall be signed with the seal.
5. Quotations are to be duly signed. Unsigned bids/offers are liable for rejection.
6. Tenders will be opened at **13:30 hrs** & the venue is New Engineering Building, 2<sup>nd</sup> floor, MM conference hall, BHEL EDN, Bangalore. All the tenderers or their authorized representatives (with authorization letter from their principals) may witness opening of techno-commercial bid on the due date.
7. After evaluation of techno-commercial bids, price bids of only those which are technically & commercially accepted, will be opened on a subsequent date, which will be intimated to the concerned in advance for witnessing of price bid opening.
8. The quantity in each item to be purchased may vary from quantity enquired according to the actual requirement at the time of placing the purchase order.

**9. DUN & BRADSTREET REPORT (for Foreign purchase):**

In case of foreign vendors, BHEL reserves the right to verify the Dun & Bradstreet report during techno-commercial scrutiny. Please mention DUN Number in **Techno-Commercial bid.**

**10. Payment of Agency Commission to Indian Agent (for Foreign purchase):**

- a. BHEL shall deal directly with foreign vendors, wherever required, for procurement of goods. However, if the foreign principal desires to avail of the services of an Indian agent, then the foreign principal should ensure compliance to regulatory guidelines - which require mandatory submission of an Agency Agreement.
- b. It shall be incumbent on the Indian agent and the foreign principal to adhere to the relevant guidelines of Government of India, issued from time to time.

**Signature of tenderer / with seal**  
**Page 2 of 12**

- c. The Agency Agreement should specify the precise relationship between the foreign OEM / foreign principal and their Indian agent and their mutual interest in the business. All services to be rendered by agent/ associate, whether of general nature or in relation to the particular contract, must be clearly stated by the foreign supplier/ Indian agent. Any payment, which the agent or associate receives in India or abroad from the OEM, whether as commission or as a general retainer fee should be brought on record in the Agreement and be made explicit in order to ensure compliance to laws of the country.
  - d. Any agency commission to be paid by BHEL to the Indian agent shall be in Indian currency only.
  - e. Tax deduction at source is applicable to the agency commission paid to the Indian agent as per the prevailing rules.
  - f. In the absence of any agency agreement, BHEL shall not deal with any Indian agent (authorized representatives / associate / consultant, or by whatever name called) and shall deal directly with the foreign principal only for all correspondence and business purposes.
  - g. The "Guidelines for Indian Agents of Foreign Suppliers" shall apply in all such cases.
  - h. The supply and execution of the Purchase Order (including indigenous supplies/ service) shall be in the scope of the OEM/ foreign principal. The OEM/ foreign principal should submit their offer inclusive of all indigenous supplies/ services and evaluation will be based on 'total cost to BHEL'. In case OEM/ foreign principal recommends placement of order(s) towards indigenous portion of supplies/ services on Indian supplier(s)/ agent on their behalf, the credentials/ capacity/ capability of the Indian supplier(s)/ agent to make the supplies/ services shall be checked by BHEL as per the extant guidelines of Supplier Evaluation, Approval & Review Procedure (SEARP), before opening of price bids. It will be the responsibility of the OEM/ foreign principal to get acquainted with the evaluation requirements of Indian supplier/ agent as per SEARP available on [www.bhel.com](http://www.bhel.com).
- The responsibility for successful execution of the contract (including indigenous supplies/ services) lies with the OEM/ foreign principal. All bank guarantees to this effect shall be in the scope of the OEM/ foreign principal.
- i. **Installation & Commissioning:** Scope will be as per RFQ.E&C value should be quoted separately by bidders.
11. **TOTAL COST TO BHEL:** Purchase order will be placed on the lowest quotation (L1) only among the technically & commercially accepted quotations. Lowest quotation (L1) is determined on the basis of the total cost to BHEL.

For Foreign offers, the Exchange rate(TT selling rate of SBI) shall be taken as under.

Single part bids	Date of Tender opening
Two/Three part bid	Date of Part-1 bid opening
Reverse Auction	Date of Part-1 bid opening

If the relevant day happens to be a bank holiday, then the forex rate as on the previous bank (SBI) working day shall be taken.

- (1) If Freight is quoted extra, original money receipt from Transporter shall be submitted for payment of Freight charges.
- (2) C-form : For issue of form "C", vendor has to furnish "E1/E2" form.

**12. FIRM PRICE:**

Rates quoted should be firm from the date of offer, till completion of supply. No enhancement in the rates and changes in the techno-commercial terms will be allowed once the quotation is accepted and order is placed.

If Installation & Commissioning is in vendor's scope, then the price shall remain FIRM till commissioning & handing over of the complete system.

**13. TERMS OF PAYMENT:**

**1. SUPPLY**

**A. : FOR FOREIGN PURCHASE**

Payment will be made against “**SIGHT DRAFT**” on presentation of documents to our bankers . Payment through LC is also made subject to loading factors as per Clause 25 (A). For LC payment bank charges within India will be borne by BHEL and outside India will be to vendor’s account.

The payment terms are as follows:

**SIGHT DRAFT PAYMENT (direct payment):**

**SUPPLY :**

(a) **I&C not included in vendor’s scope** : 90% payment of Supply value + 100% Taxes shall be made with 45 days credit from the date of receipt of material at site. Balance 10% on execution of PBG valid for warranty period + 6 months claim period from any of the BHEL Consortium banks.

(b) **Supply & I&C in vendor’s scope** : 80% payment of Supply value + 100% Taxes shall be made with 45 days credit from the date of receipt of material at site. 10% on completion of I&C and certification line item wise on pro-rata basis. Balance 10% on execution of PBG valid for warranty period + 6 months claim period from any of the BHEL Consortium banks..

**(B) FOR INDIGENOUS PURCHASE (DIRECT PAYMENT):**

**SUPPLY :**

(a) **I&C not included in vendor’s scope** : 90% payment of Supply value + 100% Taxes shall be made with 45 days credit from the date of receipt of material at site. Balance 10% on execution of PBG valid for warranty period + 6 months claim period from any of the BHEL Consortium banks.

(b) **Supply & I&C in vendor’s scope** : 80% payment of Supply value + 100% Taxes shall be made with 45 days credit from the date of receipt of material at site. 10% on completion of I&C and certification line item wise on pro-rata basis. Balance 10% on execution of PBG valid for warranty period + 6 months claim period from any of the BHEL Consortium banks.

**2. For I&C:** 100% on completion of I&C and certification line item wise on pro-rata basis.

**3. Civil Works** : 90% on completion of activity milestone and certification line item wise from site-in charge. Balance 10% against PBG for 10% of basic Civil value valid warranty period + 6 months claim period from any of the BHEL Consortium banks.

**4.O&M:** 100% O&M charges are payable as per RFQ terms against report certified by BHEL.

If PBG cannot not be submitted, vendors can also accept for the final 10% payment, payable after the warranty period + 6 months of claim period against supplementary invoice subject to the completion of commissioning (if applicable).

For any deviation in payment term, the offer will be loaded as per Clause 25.00.

**5.ADVANCE PAYMENT:** Quotations with “Advance payment” shall be liable for rejection.

**For Indigenous Vendors, Advance Payment/ Local LC terms will be liable for rejection.**

**14. PENALTY:**

Failure to supply within the delivery time as per purchase order will make the vendor liable to an unconditional penalty of 0.5 % (half percent) per week at the basic price of the goods for the undelivered quantity, subject to a maximum of 10%.

Supply : Date of issue of pre-shipment inspection/ call letter with supporting documents like test reports/conformance to test carried by the vendor will be treated as date of dispatch for the purpose of penalty calculation wherever Pre-Inspection Call is carried out.

**Signature of tenderer / with seal**  
**Page 4 of 12**

For all other activities, the actual date of completion of activity as certified by concerned site-incharge will be considered for the purpose of penalty calculation.

**15. PBG:**

Performance Bank Guarantee (PBG) to be submitted on non-judicial stamp paper as per the BHEL prescribed format given in **ANNEXURE-E for Foreign Purchase and Annexure-F for Indigenous Purchase** for 10% of the total supply value obtained from any BHEL member (consortium) banks indicated in **ANNEXURE-G**.

**The Bank Guarantee shall be submitted directly to the concerned Purchase Executive by the issuing Bank with their forwarding letter.** BHEL will verify independently with the bank to establish the authenticity. Alternately, standby LC issued from approved banker can also be considered.

**16. TERMS OF DELIVERY:**

**(a) FOR IMPORTED PURCHASE:**

Price offered shall be for goods packed and delivered **FOB** Seaport,/FCA International Airport including packing, forwarding, Handling, Ancillary charges like processing of Sight Draft, negotiation charges of bank, Export declaration, Certificate of origin etc.

Packing shall be Air/Sea worthy, best suitable for trans-shipment and to take care of transit damages. If containerized, no. of containers & size of container shall be mentioned. Packing weight (gross & net) Packing dimensions shall be given prior to shipment to ascertain whether the consignment can be carried on standard cargo in contract or as ODC.

Wooden packing material for all the foreign consignments should be treated as per ISPM-15 & **Fumigation / Phytosanitary certificate** to be submitted to the freight forwarders/ BHEL along with the invoice, B/L, packing list etc.

Vendors shall indicate the name of International Airport/Seaport. Approved Airports are as per **Annexure-C**. The consignment shall be handed over to BHEL approved freight forwarder as mentioned in PO.

**17. DELIVERY REQUIREMENT:**

Delivery date mentioned in RFQ is tentative. Actual requirement is as per RFQ terms & conditions.

**18. VALIDITY:**

Quotation should remain valid for a period of **90 days** from the date of technical bid opening.

**19. POST-ORDER REQUISITES:**

- a. Vendor shall give an Order Acknowledgement indicating the delivery date within one week of receipt of PO.
- b. Pre-shipment inspection at vendor's works, if required, will be carried out by BHEL. Required assistance will have to be provided by the vendor at the time of pre-shipment inspection.
- c. Test certificates, Calibration certificates and warranty certificates as stipulated at the time of ordering shall be furnished.
- d. Items shall be dispatched by Air worthy /Sea worthy/ Road worthy packing. Any damage and later rejection, due to poor / improper packing shall be to vendor's account.
- e. Any damage/rejection should be made good or replaced immediately without any extra cost to BHEL such as freight, duties, taxes etc. The liability is restricted to the value of the order.
- f. Wherever commissioning is involved, it shall be carried out by the vendor's qualified engineers. Scope of work includes installation, commissioning and start-up trials till satisfactory performance level is reached as certified by BHEL.
- g. BHEL will not be responsible for any loss, damage or injuries to vendor's personnel sustained during

- h. installation / commissioning / start-up trials. Vendor shall ensure compliance with all statutory requisites as laid down by local bodies, state & Central Government. Vendor shall indemnify BHEL for all damages/ losses to various personnel during their presence in BHEL"s premises for whatever purpose.
- i. Suitable markings & damage control indicating devices shall be provided where applicable.
- j. Equipment shall comply with the standard requirements of ISO 14001 & OHSAS 18001.

**20. RISK PURCHASE:**

The purchaser at his discretion may also make purchase of the materials NOT supplied in time at the RISK & COST of the supplier. In this event, it will be obligatory on the part of the supplier who fails to supply the goods in time to make good to BHEL any loss due to such risk purchase.

**21. GENERAL TERMS AND CONDITIONS GOVERNING REVERSE AUCTION (RA):**

- (a) In case of RA, BHEL will communicate business rules governing the RA to the bidders through a service provider.
- (b) BHEL EDN reserves the right to adopt Reverse Auction for the enquiry sent, at its discretion.
- (c) Confirm acceptance for RA in **ANNEXURE A/B**.

**22. REGRET LETTER:** In case any vendor is unable to quote, vendor shall send a regret letter.

**23.** Any dispute arising out of this, shall be referred to the sole arbitration of Head of Dept. Materials Management of group concerned, BHEL EDN or any other officer nominated by him and his award shall be final and binding on the parties. The venue of the arbitration in all cases shall be Bangalore, India.

**24.** Any legal suit in respect of this enquiry lies in the court of Jurisdiction of Bangalore (India) only.

**25. LOADING FACTORS:**

Loading factors as detailed below will be added to the quoted price (basic) to evaluate the lowest quote for non compliance of BHEL standard commercial term.

***A (i). For non compliance of standard Terms of payment (For Foreign Purchase Orders)***

Sl. No.	BHEL standard term	If you quote	Loading factor in % for non-compliance
1	80% against "SIGHT DRAFT" + 20% after commissioning and against PBG (where both commissioning & PBG are applicable)	Payment through Letter of Credit (LC)	10% of quoted value

In general, if the quote is through L/C, it shall be opened 30 days prior to dispatch and valid for 3 months.

***A(ii). For non compliance of standard Terms of payment (For Indigenous Purchase Orders)***

Sl. No.	BHEL standard term	If you quote	Loading factor in % for non-compliance
1	As per RFQ Terms	Any other Payment term	10% of quoted value

***A(ii). For non compliance of standard Terms of Penalty***

Sl. No.	BHEL standard term	If you quote	Loading factor for non-compliance
1	Penalty of 0.5% per week	Other than the above.	Loading Factor 10%-Quoted Max %
	subject to max. of 10% on the		
	basic value of the items not		
	supplied /delayed		

**LIST OF INTERNATIONAL AIRPORTS**

<b>Sl. No</b>	<b>Country</b>	<b>Air Ports</b>
1	Austria	Vienna, Linz, Graz
2	Australia	Sydney, Melbourne, Perth
3	Belgium	Antwerp, Brussels
4	Canada	Toronto, Montreal
5	China	Shanghai
6	Cyprus	Lamaca
7	Czech Republic	Prague (Via Frankfurt)
8	Denmark	Copenhagen
9	Egypt	Cairo
10	Finland	Helsinki
11	France	Paris (Rosy), Lyon
12	Germany	Darmstadt, Mannheim, Nurnberg, Hamburg, Stuttgart, Munich, Koln, Dusseldorf & Hannover, Frankfurt, Berlin
13	Hong Kong	Hong Kong
14	Italy	Rome, Milan, Turin, Bologna, Florence
15	Ireland	Dublin
16	Israel	Telaviv
17	Japan	Tokyo, Osaka
18	Malaysia	Kuala lumpur, Penang
19	Netherlands	Amsterdam, Rotterdam
20	New Zealand	Auckland
21	Norway	Oslo
22	Oman	Muscat
23	Philippines	Manila
24	Romania	Bucharest
25	Russia	Moscow
26	Saudi Arabia	Riyad
27	Singapore	Singapore
28	Slovakia	Bartislowa
29	South Africa	Johannesburg, Durban
30	South Korea	Kimpo
31	Spain	Barcelona
32	Sweden	Stockholm, Gothenburg, Milano
33	Switzerland	Basle, Zurich, Geneva
34	Taiwan	Taipei
35	U.A.E.	Dubai
36	U.K.	Landon (Heathrow), Newcastle, Oxford, Cheltham, Bristol, Welling borough, Birmingham, East Midland, Manchester, Leeds, Glasgow.
37	U.S.A.	New York, Chicago, San Francisco, Los Angeles, Atlanta
38	Ukraine	Kiev

**BHEL EDN APPROVED TRANSPORTERS FOR INLAND ROAD TRANSPORTATION**

1. M/s Awagaman Road Carriers ltd., Bangalore. (AWG)
2. M/s BLR India Pvt. Ltd., Bangalore. (BLR)
3. M/s Delhi Assam Roadways corporation ltd., Bangalore. (DRL)
4. M/s Indo Arya Central transport ltd., Bangalore. (IACT)
5. M/s Prakash parcel Services, Bangalore. (PPS)
6. M/s Road Carrier of India, Bangalore. (RCI)
7. M/s Union Roadways ltd., Bangalore. (URL)

Signature of tenderer / with seal  
Page 7 of 12

**PERFORMANCE BANK GUARANTEE**  
**(FOR FOREIGN PURCHASE ORDERS)**  
**BANK NAME AND ADDRESS**

Bharat Heavy Electricals Limited (BHEL),  
Electronics Division,  
PB No. 2606,  
Mysore Road,  
BANGALORE- 560 026  
INDIA

Dear Sir,  
Ref: CONTRACT PERFORMANCE GUARANTEE.

WHEREAS you have entered into a contract reference No PO NO. \_\_\_\_\_

wit

h M/s

\_\_\_\_\_ having its registered office at \_\_\_\_\_ for the supply of \_\_\_\_\_ as detailed in your purchase order No. \_\_\_\_\_ which is hereinafter referred to as "the said contract" and whereas M/s \_\_\_\_\_ has undertaken to produce a Bank Guarantee for 10% ( Ten Percent ) of \_\_\_\_\_ the contract price amounting to \_\_\_\_\_ (\_\_\_\_\_

\_\_\_\_\_ ) to secure its obligations to Electronics Division, BHEL having its registered office at New Delhi for the performance of the contract including the warranty of the equipment supplied, We \_\_\_\_\_ Bank, \_\_\_\_\_ hereby expressly, irrevocably and unreservedly undertake and guarantee as principal obligors on behalf of M/s \_\_\_\_\_ that in the event Bharat Heavy Electricals Ltd. (B.H.E.L.) declares to us in writing that M/s \_\_\_\_\_ has not fulfilled any obligation according to the contractual obligation of the said contract, to pay you on demand and without demur to Bharat Heavy Electricals Ltd., Electronics Division, Mysore Road, P.B. No. 2606, Bangalore-560 026, India an amount of \_\_\_\_\_ (in words \_\_\_\_\_ ) subject to as may be determined below:

- 1) Notwithstanding any right M/s. \_\_\_\_\_ may have directly against you or any disputes raised by M/s \_\_\_\_\_, Your written demand shall be conclusive evidence to us that repayment is due under the terms of the said contract and shall be binding on us.
- 2) We shall not be discharged or released from this undertaking and Guarantee by any arrangements, variations made between you and M/s. \_\_\_\_\_ with or without our consent and Knowledge or by any alterations in the obligations of M/s. \_\_\_\_\_ by any forbearance whether as to payment, time, performance or otherwise.
- 3) This guarantee shall remain valid until the end of twenty four weeks after the close of the warranty period or until the same is reported by BHEL to us whichever is earlier.
- 4) We agree and undertake not to revoke this guarantee during its validity unless discharged in writing by you subject to the provision of clause (7) below.
- 5) This guarantee shall be a continuing guarantee subject to the foregoing and shall not be discharged by any change in the constitution of the Bank or M/s. \_\_\_\_\_.
- 6) This guarantee shall be governed by and constructed in accordance with the Laws of India.
- 7) At any time \_\_\_\_\_ Bank may render this guarantee null and void by paying to Bharat Heavy Electricals Ltd. the full amount being \_\_\_\_\_ (in words \_\_\_\_\_ )

For and on behalf of Bank  
by its Authorized  
Signatory

**Note:**

**Signature of tenderer / with seal**  
**Page 8 of 12**

- (1) To be executed in Non-Judicial stamp paper by any authorized Indian Bank.
- (2) To be submitted directly by banker to concerned executive in purchase dept., Please give BHEL address to banker.
- (3) Do not enclose with Bank document.
- (4) Any Modification & omissions to this are not permitted

**PERFORMANCE BANK GUARANTEE**  
**(FOR INDIGENOUS PURCHASE ORDERS)**

THIS DEED OF GUARANTEE made and executed on the \_\_\_\_\_ day of \_\_\_\_\_(year), by the \_\_\_\_\_ (Bank), registered under the Companies Act 1956/Nationalized Bank constituted under the Banking Companies (acquisition and transfer of undertakings) Act constituted under the State Bank of India Act / Subsidiary Banks Act, having its registered / head office at \_\_\_\_\_ represented herein by its Branch Manager / authorized representative Sri. \_\_\_\_\_ & Sri. \_\_\_\_\_(Hereinafter called 'guarantor ' which term shall mean and include its successors and assigns)

**IN FAVOUR OF BHARAT HEAVY ELECTRICALS LIMITED**

\_\_\_\_\_ (Buyer's Name), a company registered under the companies Act, 1956 having its registered office at BHEL House at Siri Fort , New Delhi-100 049 and its Electronics Division at Mysore road, Bangalore-26 (hereinafter referred to as the 'Company' Which term shall include its successors and assigns):

Whereas the company has placed an order on \_\_\_\_\_ (State the name of the company / firm and its address) (hereinafter referred to as the 'Supplier' which term shall mean and include its liquidators, successors and assign) for the supply of system under order / Contract No \_\_\_\_\_ Dt \_\_\_\_\_.

AND WHEREAS the supplier has agreed to supply the materials and carryout the works as detailed and in accordance with the terms set out in the said order/contract.

AND WHEREAS the company is not required to pay to the supplier a sum of Rupees \_\_\_\_\_ being the 10% of the value of the goods supplied / Works performed / Services rendered under the said order / contract between the supplier and the company, till the company is satisfied with the mechanical Warranties and the performance standards stipulated in the said order / contract between the company and the supplier has been duly fulfilled, except against a Bank Guarantee for the said sum of Rs \_\_\_\_\_ in favour of the company by reputed Bank, in which case the company has agreed to make payment to the supplier of the said sum of Rupees \_\_\_\_\_ being ( ...% ) of the value of the goods supplied / Works performed / Services rendered under the agreement between the supplier and the company and the Guarantor has at the request of the supplier, agreed to furnish this Guarantee subject to the terms and conditions stated below:

NOW THIS DEED WITNESSES THAT IN pursuance of the above said agreement, the guarantor hereby agrees and covenants With company is as follows :-

- 1) That during the period this contract of Guarantee remains effectual, the guarantor shall be liable in respect of the amount due and owing to the company in respect of the payments to the extent of Rs \_\_\_\_\_ (in words) \_\_\_\_\_ against any loss or damage caused to or suffered by the company by reasons of any breach of the terms of the said order / contract / Agreement by the supplier.
- 2) The Guarantor hereby undertakes to pay the amounts due and payable under this guarantee without any demur, merely on demand from the company intimating that the amount claimed is due by way of loss or damage caused to or suffered or would be caused or suffered by the supplier of any terms contained in the said order / contract. Any such demand made on the guarantor shall be conclusive as regards the amount due and payable by the Guarantor irrespective of the fact whether the Contractor / supplier admits or denies.
- 3) The Guarantor further agrees that the agreement herein contained shall remain in force and effect till all the supplies to be made / Works to be performed / Services to be rendered under the said order / contract / agreement are completed to the entire satisfaction of the company or till company certifies that the terms and conditions of the said order / contract / agreement have been fully and properly carried out by the said supplier and accordingly discharges the Guarantee. Unless a demand or claim under this guarantee is made on the guarantor in writing on or before the expiry of claim period indicated in clause 6 below, the guarantor shall be discharged from all the liability under this guarantee thereafter.
- 4) The guarantor further agrees with the company that the company shall have the fullest liberty without the consent of the guarantor and without effecting in any manner the obligations of the guarantor hereunder to vary any of the terms of the said order / contract / agreement or extend the time of performance by the said supplier from time to time or refrain from exercising the power exercisable by the company against the said supplier or to forebear or omit to enforce any of the terms and conditions relating to the said order / contract / agreement, and the guarantor shall not be relieved of its liability in whole or in part , by reason of any act, commission or forbearance on the part of the company or by reason of any such variation, or extension being granted to the said

**Signature of tenderer / with seal**  
**Page 10 of 12**

supplier or by reason of any such matter or thing whatsoever which under the law relating to sureties would but for this provision have effect of so relieving the guarantor.

- 5) The guarantor undertakes not to revoke this guarantee during its currency except with the previous consent of the company in writing.
- 6) Notwithstanding anything herein above contained, the liability of the guarantor under these presents is restricted to Rs\_\_\_\_\_. The guarantee shall be in force till its expiry on \_\_\_\_\_ unless a demand is made on the guarantor within SIX months from the date of expiry, all the liability of the guarantor under this guarantee shall stand fully discharged. The decision of the claimant in regard to breach of contract is final and binding on the Bank.

IN WITNESS whereof, the guarantor, acting through its authorized representative has executed this deed of Guarantee on the day, month and year first above written.

(Seal of the Bank to be affixed)

WITNESS

- 1.
- 2.

**Note:**

- (1) To be executed in INR 100 Non-Judicial stamp paper by any authorized Indian Bank.
- (2) To be submitted directly by banker to concerned executive in purchase dept., Please give BHEL address to banker.
- (3) Do not enclose with Bank document.
- (4) Any Modification & omissions to this are not permitted.

**BHEL MEMBER BANKS (CONSORTIUM BANKS)**

PBG SHALL BE ISSUED FROM THE FOLLOWING BANKS OR THEIR BRANCH OFFICES ONLY

1	STATE BANK OF INDIA
2	PUNJAB NATIONAL BANK
3	HDFC BANK
4	SYNDICATE BANK
5	CANARA BANK
6	INDIAN BANK
7	ST. BANK OF HYDERABAD
8	ICICI BANK
9	STANDARD CHARTERED BANK
10	UCO BANK
11	KOTAK MAHINDRA
12	ORIENTAL BANK OF COMMERCE
13	STATE BANK OF TRAVANCORE
14	CENTRAL BANK
15	IDBI BANK
16	FEDERAL BANK
17	HSBC LTD
18	DEUTSCHE BANK
19	CORPORATION BANK
20	CITI BANK
21	BANK OF BARODA
22	ABN AMRO BANK
23	UNITED BANK OF INDIA
24	VIJAYA BANK
25	UNION BANK OF INDIA
26	PUNJAB & SIND BANK
27	ANDHRA BANK
28	BANK OF INDIA
29	AXIS BANK