

FIRST ANGLE PROJECTION

ALL DIMENSIONS ARE IN mm.

THE INFORMATION ON THIS DOCUMENT IS THE PROPERTY OF BHARAT HEAVY ELECTRICALS LIMITED. IT MUST NOT BE USED DIRECTLY OR INDIRECTLY IN ANY WAY DETRIMENTAL TO THE INTEREST OF THE COMPANY.

REV.	DATE	ALTERED	REV.	DATE	ALTERED	REV.	DATE	ALTERED
		CHECKED			CHECKED			CHECKED
		APPROVED			APPROVED			APPROVED

# INSTRUMENTS HOOKUP DIAGRAMS

COMPUTER NO.



REF. DRG. NO.  
**HOOKUP1.DWG**

SIGN. & DATE

INVENTORY NO.

DESCRIPTION & DRG.NO.	VAR NO.	RAW MATERIAL SIZE OR CASTING DRG.NO. OR FORGING DRG.NO.	MATL. CODE	NET.WT.	GROSS WT
			MATL. SPECN.	QTY.	

TYPE OF PRODUCT OR NAME OF CUSTOMER/PROJECT

REF. TO HY0230261 FOR UNSPECIFIED TOLERANCES.	 भारत हेवी इलेक्ट्रिकल्स लिमिटेड हैदराबाद BHARAT HEAVY ELECTRICALS LTD. HYDERABAD	DRN.	P.S.V.S	DATE	27.12.10	NO.OF VAR. <b>-NA-</b>	
		CKD.	P.S.V.S	DATE	27.12.10		
		APPD.	V.V.S	DATE	27.12.10		
DEPT.	T.C.E.I	 SCALE <b>-NA-</b>	WEIGHT(K.G.)	<b>-NA-</b>	REF.TO ASSY.DRG.	ITEM NO.	NO.OF ITEM
CODE	415		<b>-NA-</b>	<b>-NA-</b>	<b>-NA-</b>	<b>-NA-</b>	<b>-NA-</b>
TITLE		<b>INSTRUMENTS HOOKUP DIAGRAMS</b>		DRAWING NO.		REV.	
				<b>4-312-00-50126</b>		<b>00</b>	
		SHT.NO.	01	NO.OF SHT.		44	

FIRST ANGLE PROJECTION

ALL DIMENSIONS ARE IN mm.

REV.	DATE	ALTERED	REV.	DATE	ALTERED	REV.	DATE	ADDITIONAL INFORMATION
		CHECKED			CHECKED			STATUS OF DRAWING

APPROVED

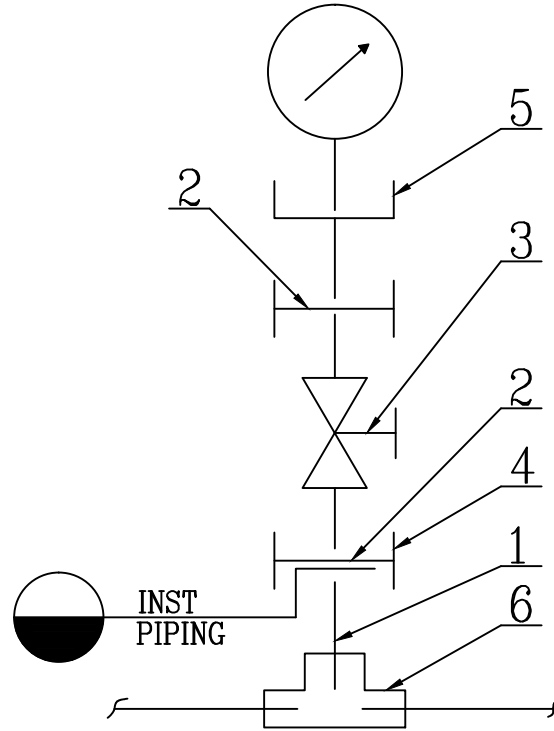
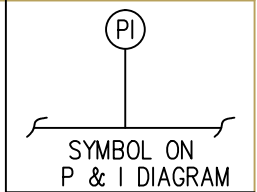

THE INFORMATION ON THIS DOCUMENT IS THE PROPERTY OF BHARAT HEAVY ELECTRICALS LIMITED. IT MUST NOT BE USED DIRECTLY OR INDIRECTLY IN ANY WAY DETRIMENTAL TO THE INTEREST OF THE COMPANY.

REF. DRG. NO.	COMPUTER NO.			
HOOKUP2.DWG				
ITEM NO.	DESCRIPTION.	DRAWING NO.	MATL. CODE	GROSS WT
			MATL. SPECN.	QTY.

BHARAT HEAVY ELECTRICALS LTD. HYDERABAD	DRN.	R.BIJU	-SD-	18.11.93	NO.OF VAR.
	CKD.	G.R.REDDY	-SD-	18.12.93	-NA-
	APPD.	G.R.REDDY	-SD-	18.12.93	-NA-
DEPT. T.C.E.I	SCALE WEIGHT(K.G.)	REF.TO ASSY.DRG.	ITEM NO.	NO.OF ITEM	
CODE 415	-NA- -NA-	-NA-	-NA-	-NA-	-NA-
TITLE LOCAL DIRECT MOUNTED PRESSURE GAUGE CONNECTION -JACKING OIL PIPE LINES		DRAWING NO. 4-312-00-50126		REV. 00	
		SHT.NO. 02	NO.OF SHT. 44		

FIRST ANGLE PROJECTION

ALL DIMENSIONS ARE IN mm.

REV.	DATE	ALTERED	REV.	DATE	ALTERED	REV.	DATE	ADDITIONAL INFORMATION
		CHECKED			CHECKED			STATUS OF DRAWING
								APPROVED



**EXECUTION-I (CARBON STEEL)**

POS No.	DESCRIPTION	DIMENSION	MATERIAL	CODE	QTY
1	EXTENSION (NP 640)	M20x1.5L	IS 1570 C40N	HY7316663022	1
2	FLAT SEALING	ø20	ALUMINIUM	HY7161094828	2
3	PRESSURE GAUGE VALVE (NP 250)	M20x1.5	A 105	AA7316402016	1
4	PRESSURE GAUGE COUPLING (NP 640)	M20x1.5L	C40N	HY7316664029	1
5	ADAPTOR	1/2"NPT-F/ M20x1.5-M	A105	TC9756219017	1
6	SPL. TEE	-	A 105	-	1

**EXECUTION-II (STAINLESS STEEL)**

POS No.	DESCRIPTION	DIMENSION	MATERIAL	CODE	QTY
1	EXTENSION (NP 640)	M20x1.5L	STAINLESS STEEL	HY7316663111	1
2	FLAT SEALING	ø20	ALUMINIUM	HY7161094828	2
3	PRESSURE GAUGE VALVE (NP 250)	M20x1.5	A182-F316	AA7316402202	1
4	PRESSURE GAUGE COUPLING (NP 640)	M20x1.5L	A182-F316	HY7316664037	1
5	ADAPTOR	1/2"NPT-F/ M20x1.5-M	A182-F321	TC9756219025	1
6	SPL. TEE	-	A182-F321	-	1

ITEM NO.	DESCRIPTION.	DRAWING NO.	MATL. CODE	GROSS WT
			MATL. SPECN.	QTY.

 <b>BHARAT HEAVY ELECTRICALS LTD.</b> HYDERABAD	DRN.	R.BIJU	-SD-	18.11.93	NO.OF VAR.	
	CKD.	G.R.REDDY	-SD-	18.12.93	-NA-	
	APPD.	G.R.REDDY	-SD-	18.12.93	-NA-	
DEPT. T.C.E.I		SCALE	WEIGHT(K.G.)	REF.TO ASSY.DRG.	ITEM NO.	NO.OF ITEM
CODE 415		-NA-	-NA-	-NA-	-NA-	-NA-
TITLE				DRAWING NO.	REV.	
BILL OF MATERIAL FOR SHEET 2				4-312-00-50126	00	
				SHT.NO. 03	NO.OF SHT. 44	

THE INFORMATION ON THIS DOCUMENT IS THE PROPERTY OF BHARAT HEAVY ELECTRICALS LIMITED. IT MUST NOT BE USED DIRECTLY OR INDIRECTLY IN ANY WAY DETRIMENTAL TO THE INTEREST OF THE COMPANY.

REF. DRG. NO. COMPUTER NO. INVENTORY NO. SIGN. & DATE HOOKUP.3.DWG

FIRST ANGLE PROJECTION

ALL DIMENSIONS ARE IN mm.

REV.	DATE	ALTERED	REV.	DATE	ALTERED	REV.	DATE	ADDITIONAL INFORMATION
		CHECKED			CHECKED			STATUS OF DRAWING
								APPROVED

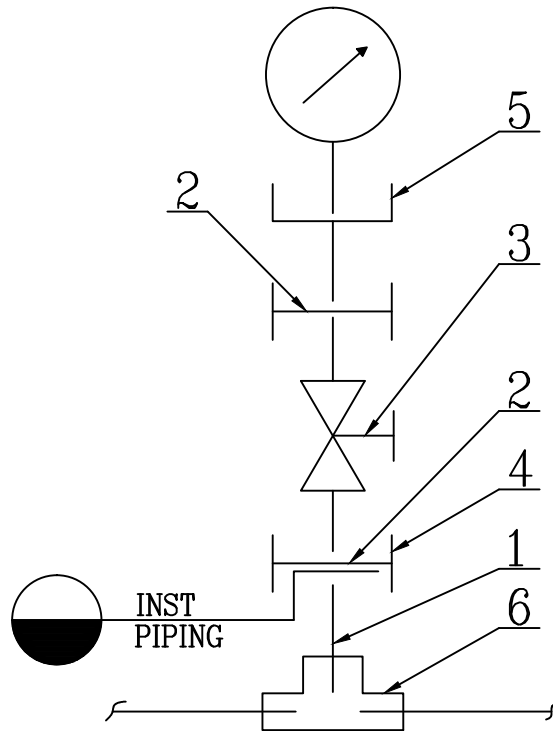
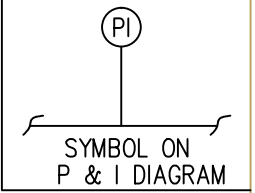

FOR PIPES 3/4"

THE INFORMATION ON THIS DOCUMENT IS THE PROPERTY OF BHARAT HEAVY ELECTRICALS LIMITED. IT MUST NOT BE USED DIRECTLY OR INDIRECTLY IN ANY WAY DETRIMENTAL TO THE INTEREST OF THE COMPANY.

REF. DRG. NO.	COMPUTER NO.			
HOOKUP4.DWG				
ITEM NO.	DESCRIPTION.	DRAWING NO.	MATL. CODE	GROSS WT
			MATL. SPECN.	QTY.

SIGN. & DATE	BHARAT HEAVY ELECTRICALS LTD. HYDERABAD	DRN.	R.BIJU	-SD-	18.11.93	NO.OF VAR.	
		CKD.	G.R.REDDY	-SD-	18.12.93	-NA-	
		APPD.	G.R.REDDY	-SD-	18.12.93	-NA-	
INVENTORY NO.	DEPT.	T.C.E.I	SCALE	WEIGHT(K.G.)	REF.TO ASSY.DRG.	ITEM NO.	NO.OF ITEM
	CODE	415	-NA-	-NA-	-NA-	-NA-	-NA-
TITLE LOCAL DIRECT MOUNTED PRESSURE GAUGE CONNECTION OIL,WATER,PROCESS GAS PIPE LINES (3/4" PIPES)					DRAWING NO.	REV.	
					4-312-00-50126	00	
					SHT.NO. 04	NO.OF SHT. 44	

FIRST ANGLE PROJECTION

ALL DIMENSIONS ARE IN mm.

REV.	DATE	ALTERED	REV.	DATE	ALTERED	REV.	DATE	ADDITIONAL INFORMATION
		CHECKED			CHECKED			STATUS OF DRAWING
								APPROVED



**EXECUTION-I (CARBON STEEL)**

POS No.	DESCRIPTION	DIMENSION	MATERIAL	CODE	QTY
1	ADAPTOR	3/4"/M20x1.5	A 105	TC9756218010	1
2	FLAT SEALING	Ø20	ALUMINIUM	HY7161094828	2
3	PRESSURE GAUGE VALVE (NP 250)	M20x1.5	A 105	AA7316402016	1
4	PRESSURE GAUGE COUPLING (NP 640)	M20x1.5	C40N	HY7316664029	1
5	ADAPTOR	1/2"NPT-F/ M20x1.5-M	A105	TC9756219017	1
6	SPL. TEE	-	A 105	-	1

**EXECUTION-II (STAINLESS STEEL)**

POS No.	DESCRIPTION	DIMENSION	MATERIAL	CODE	QTY
1	ADAPTER	3/4"/M20x1.5	A 105	TC9756218037	1
2	FLAT SEALING	Ø20	ALUMINIUM	HY7161094828	2
3	PRESSURE GAUGE VALVE (NP 250)	M20x1.5	A182-F316	AA7316402202	1
4	PRESSURE GAUGE COUPLING (NP 640)	M20x1.5	A182-F316	HY7316664037	1
5	ADAPTOR	1/2"NPT-F/ M20x1.5-M	A182-F321	TC9756219025	1
6	SPL. TEE	-	A182-F321	-	1

ITEM NO.	DESCRIPTION.	DRAWING NO.	MATL. CODE	GROSS WT
			MATL. SPECN.	QTY.

 <b>BHARAT HEAVY ELECTRICALS LTD.</b> HYDERABAD	DRN.	R.BIJU	-SD-	18.11.93	NO.OF VAR.		
	CKD.	G.R.REDDY	-SD-	18.12.93	-NA-		
	APPD.	G.R.REDDY	-SD-	18.12.93	-NA-		
DEPT.	T.C.E.I		SCALE	WEIGHT(K.G.)	REF.TO ASSY.DRG.	ITEM NO.	NO.OF ITEM
CODE	415		-NA-	-NA-	-NA-	-NA-	-NA-
TITLE					DRAWING NO.	REV.	
BILL OF MATERIAL FOR SHEET 4					4-312-00-50126	00	
SHT.NO. 05				NO.OF SHT. 44			

REF. DRG. NO. COMPUTER NO. THE INFORMATION ON THIS DOCUMENT IS THE PROPERTY OF BHARAT HEAVY ELECTRICALS LIMITED. IT MUST NOT BE USED DIRECTLY OR INDIRECTLY IN ANY WAY DETRIMENTAL TO THE INTEREST OF THE COMPANY.  
 HOOKUP5.DWG  
 SIGN. & DATE  
 INVENTORY NO.

FIRST ANGLE PROJECTION

ALL DIMENSIONS ARE IN mm.

REV.	DATE	ALTERED	REV.	DATE	ALTERED	REV.	DATE	ADDITIONAL INFORMATION
		CHECKED			CHECKED			STATUS OF DRAWING

APPROVED

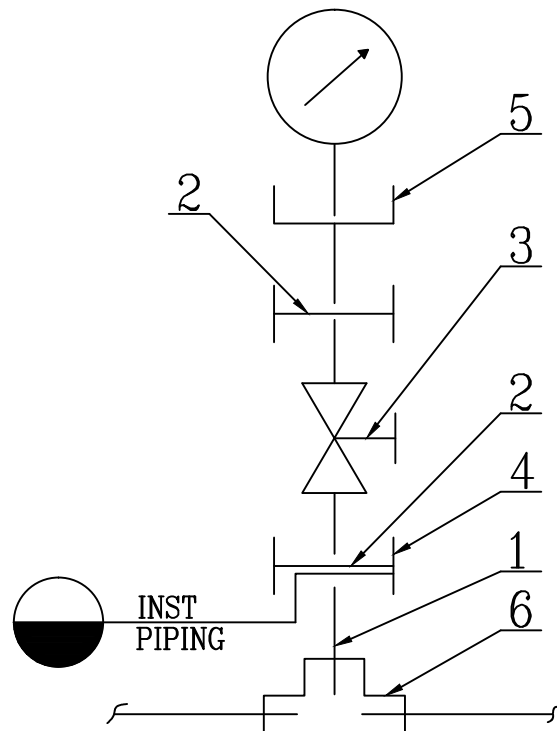
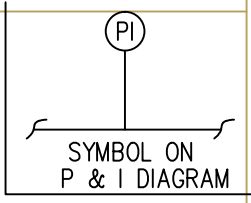

FOR PIPES 1"

THE INFORMATION ON THIS DOCUMENT IS THE PROPERTY OF BHARAT HEAVY ELECTRICALS LIMITED. IT MUST NOT BE USED DIRECTLY OR INDIRECTLY IN ANY WAY DETRIMENTAL TO THE INTEREST OF THE COMPANY.

REF. DRG. NO. COMPUTER NO. HOOKUP6.DWG

SIGN. & DATE INVENTORY NO.

ITEM NO.	DESCRIPTION.	DRAWING NO.	MATL. CODE	GROSS WT
			MATL. SPECN.	QTY.

BHARAT HEAVY ELECTRICALS LTD. HYDERABAD	DRN.	R.BIJU	-SD-	18.11.93	NO.OF VAR.	
	CKD.	G.R.REDDY	-SD-	18.12.93	-NA-	
	APPD.	G.R.REDDY	-SD-	18.12.93	-NA-	
DEPT. T.C.E.I		SCALE	WEIGHT(K.G.)	REF.TO ASSY.DRG.	ITEM NO.	NO.OF ITEM
CODE 415		-NA-	-NA-	-NA-	-NA-	-NA-
TITLE LOCAL DIRECT MOUNTED PRESSURE GAUGE CONNECTION OIL,WATER,PROCESS GAS PIPE LINES (1" PIPE)				DRAWING NO. 4-312-00-50126		REV. 00
			SHT.NO. 06	NO.OF SHT. 44		

FIRST ANGLE PROJECTION

ALL DIMENSIONS ARE IN mm.

REV.	DATE	ALTERED	REV.	DATE	ALTERED	REV.	DATE	ADDITIONAL INFORMATION
		CHECKED			CHECKED			STATUS OF DRAWING
								APPROVED



**EXECUTION-I (CARBON STEEL)**

POS No.	DESCRIPTION	DIMENSION	MATERIAL	CODE	QTY
1	ADAPTOR	1"/M20x1.5	A 105	TC9756218029	1
2	FLAT SEALING	Ø20	ALUMINIUM	HY7161094828	2
3	PRESSURE GAUGE VALVE (NP 250)	M20x1.5	A 105	AA7316402016	1
4	PRESSURE GAUGE COUPLING (NP 640)	M20x1.5	C40N	HY7316664029	1
5	ADAPTOR	1/2"NPT-F/ M20x1.5-M	A105	TC9756219017	1
6	SPL. TEE	-	A 105	-	1

**EXECUTION-II (STAINLESS STEEL)**

POS No.	DESCRIPTION	DIMENSION	MATERIAL	CODE	QTY
1	ADAPTER	1"/M20x1.5	A 105	TC9756218045	1
2	FLAT SEALING	Ø20	ALUMINIUM	HY7161094828	2
3	PRESSURE GAUGE VALVE (NP 250)	M20x1.5	A182-F316	AA7316402202	1
4	PRESSURE GAUGE COUPLING (NP 640)	M20x1.5	A182-F316	HY7316664037	1
5	ADAPTOR	1/2"NPT-F/ M20x1.5-M	A182-F321	TC9756219025	1
6	SPL. TEE	-	A182-F321	-	1

ITEM NO.	DESCRIPTION.	DRAWING NO.	MATL. CODE	GROSS WT
			MATL. SPECN.	QTY.

 <b>BHARAT HEAVY ELECTRICALS LTD.</b> HYDERABAD	DRN.	R.BIJU	-SD-	18.11.93	NO.OF VAR.
	CKD.	G.R.REDDY	-SD-	18.12.93	-NA-
	APPD.	G.R.REDDY	-SD-	18.12.93	-NA-
DEPT. T.C.E.I		SCALE	WEIGHT(K.G.)	REF.TO ASSY.DRG.	ITEM NO.
CODE 415		-NA-	-NA-	-NA-	-NA-
TITLE				DRAWING NO.	REV.
BILL OF MATERIAL FOR SHEET 6				4-312-00-50126	00
				SHT.NO. 07	NO.OF SHT. 44

THE INFORMATION ON THIS DOCUMENT IS THE PROPERTY OF BHARAT HEAVY ELECTRICALS LIMITED. IT MUST NOT BE USED DIRECTLY OR INDIRECTLY IN ANY WAY DETRIMENTAL TO THE INTEREST OF THE COMPANY.

REF. DRG. NO. COMPUTER NO. HOOKUP7.DWG

SIGN. & DATE

INVENTORY NO.

FIRST ANGLE PROJECTION

ALL DIMENSIONS ARE IN mm.

REV.	DATE	ALTERED	REV.	DATE	ALTERED	REV.	DATE	ADDITIONAL INFORMATION
		CHECKED			CHECKED			STATUS OF DRAWING
								APPROVED

THE INFORMATION ON THIS DOCUMENT IS THE PROPERTY OF BHARAT HEAVY ELECTRICALS LIMITED. IT MUST NOT BE USED DIRECTLY OR INDIRECTLY IN ANY WAY DETRIMENTAL TO THE INTEREST OF THE COMPANY.

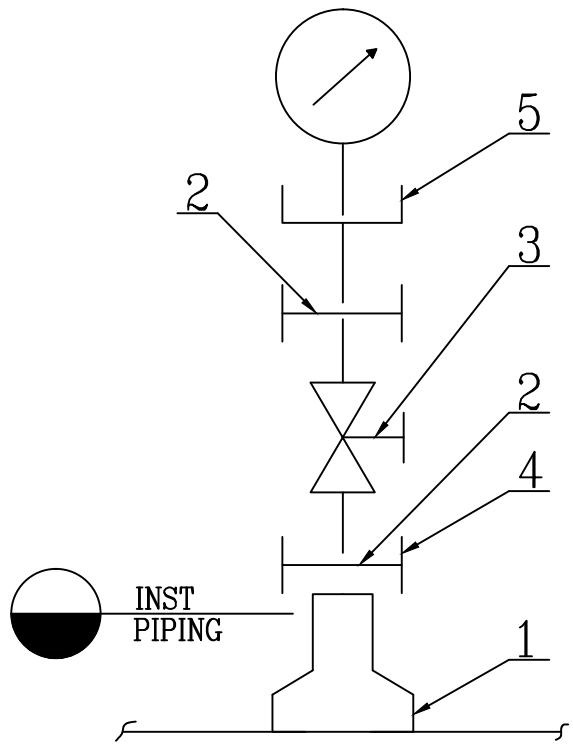
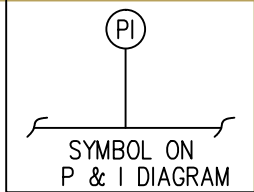



FOR PIPES 1 1/2" AND ABOVE

REF. DRG. NO. COMPUTER NO.  
HOOKUP8.DWG

ITEM NO.	DESCRIPTION.	DRAWING NO.	MATL. CODE	GROSS WT
			MATL. SPECN.	QTY.

SIGN. & DATE  
INVENTORY NO.

 BHARAT HEAVY ELECTRICALS LTD. HYDERABAD	DRN.	R.BIJU	-SD-	18.11.93	NO.OF VAR.	
	CKD.	G.R.REDDY	-SD-	18.12.93	-NA-	
	APPD.	G.R.REDDY	-SD-	18.12.93	-NA-	
DEPT. T.C.E.I		SCALE	WEIGHT(K.G.)	REF.TO ASSY.DRG.	ITEM NO.	NO.OF ITEM
CODE 415		-NA-	-NA-	-NA-	-NA-	-NA-
TITLE LOCAL DIRECT MOUNTED PRESSURE GAUGE CONNECTION OIL,WATER,PROCESS GAS PIPE LINES				DRAWING NO. 4-312-00-50126	REV. 00	
				SHT.NO. 08	NO.OF SHT. 44	

FIRST ANGLE PROJECTION

ALL DIMENSIONS ARE IN mm.

REV. DATE	ALTERED	REV. DATE	ALTERED	REV. DATE	ADDITIONAL INFORMATION
	CHECKED		CHECKED		STATUS OF DRAWING
					APPROVED



**EXECUTION-I (CARBON STEEL)**

POS No.	DESCRIPTION	DIMENSION	MATERIAL	CODE	QTY
1	EXTENSION (NP 640)	M20x1.5L	C40N	HY7316663022	1
2	FLAT SEALING	Ø20	ALUMINIUM	HY7161094828	2
3	PRESSURE GAUGE VALVE (NP 250)	M20x1.5	A 105	AA7316402016	1
4	PRESSURE GAUGE COUPLING (NP 640)	M20x1.5	C40N	HY7316664029	1
5	ADAPTOR	1/2"NPT-F/ M20x1.5-M	A105	TC9756219017	1

**EXECUTION-II (STAINLESS STEEL)**

POS No.	DESCRIPTION	DIMENSION	MATERIAL	CODE	QTY
1	EXTENSION (NP 640)	M20x1.5L	A182-F321	TC9756216026	1
2	FLAT SEALING	Ø20	ALUMINIUM	HY7161094828	2
3	PRESSURE GAUGE VALVE (NP 250)	M20x1.5	A182-F316	AA7316402202	1
4	PRESSURE GAUGE COUPLING (NP 640)	M20x1.5	A182-F316	HY7316664037	1
5	ADAPTOR	1/2"NPT-F/ M20x1.5-M	A182-F321	TC9756219025	1

ITEM NO.	DESCRIPTION.	DRAWING NO.	MATL. CODE	GROSS WT
			MATL. SPECN.	QTY.

 <b>BHARAT HEAVY ELECTRICALS LTD.</b> HYDERABAD	DRN.	R.BIJU	-SD-	18.11.93	NO.OF VAR.
	CKD.	G.R.REDDY	-SD-	18.12.93	-NA-
	APPD.	G.R.REDDY	-SD-	18.12.93	-NA-
DEPT. T.C.E.I		SCALE	WEIGHT(K.G.)	REF.TO ASSY.DRG.	ITEM NO.
CODE 415		-NA-	-NA-	-NA-	-NA-
TITLE				DRAWING NO.	REV.
BILL OF MATERIAL FOR SHEET 8				4-312-00-50126	00
SHT.NO. 09			NO.OF SHT. 44		

REF. DRG. NO. COMPUTER NO. INVENTORY NO. SIGN. & DATE  
 HOOKUP9.DWG  
 THE INFORMATION ON THIS DOCUMENT IS THE PROPERTY OF BHARAT HEAVY ELECTRICALS LIMITED. IT MUST NOT BE USED DIRECTLY OR INDIRECTLY IN ANY WAY DETRIMENTAL TO THE INTEREST OF THE COMPANY.

FIRST ANGLE PROJECTION

ALL DIMENSIONS ARE IN mm.

REV.	DATE	ALTERED	REV.	DATE	ALTERED	REV.	DATE	ADDITIONAL INFORMATION
		CHECKED			CHECKED			STATUS OF DRAWING

APPROVED

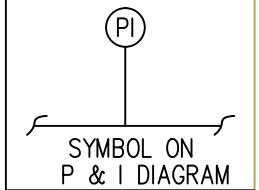
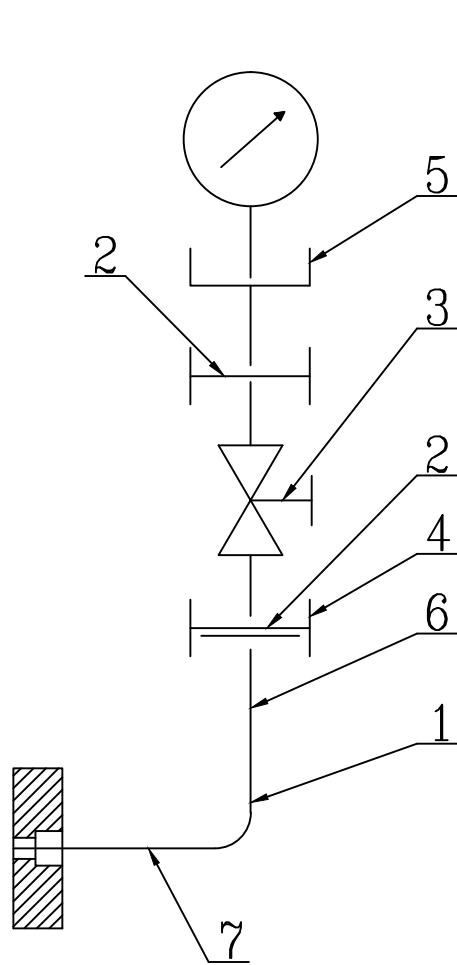

THE INFORMATION ON THIS DOCUMENT IS THE PROPERTY OF BHARAT HEAVY ELECTRICALS LIMITED. IT MUST NOT BE USED DIRECTLY OR INDIRECTLY IN ANY WAY DETRIMENTAL TO THE INTEREST OF THE COMPANY.



REF. DRG. NO. COMPUTER NO. HOOKUP10.DWG

ITEM NO.	DESCRIPTION.	DRAWING NO.	MATL. CODE	GROSS WT
			MATL. SPECN.	QTY.

SIGN. & DATE INVENTORY NO.

 BHARAT HEAVY ELECTRICALS LTD. HYDERABAD	DRN.	R.BIJU	-SD-	18.11.93	NO.OF VAR.	
	CKD.	G.R.REDDY	-SD-	18.12.93	-NA-	
	APPD.	G.R.REDDY	-SD-	18.12.93	-NA-	
DEPT. T.C.E.I		SCALE	WEIGHT(K.G.)	REF.TO ASSY.DRG.	ITEM NO.	NO.OF ITEM
CODE 415		-NA-	-NA-	-NA-	-NA-	-NA-
TITLE LOCAL DIRECT MOUNTED PRESSURE GAUGE CONNECTION STOP VALVE TESTER				DRAWING NO. 4-312-00-50126		REV. 00
				SHT.NO. 10	NO.OF SHT. 44	

FIRST ANGLE PROJECTION

ALL DIMENSIONS ARE IN mm.

REV.	DATE	ALTERED	REV.	DATE	ALTERED	REV.	DATE	ADDITIONAL INFORMATION
		CHECKED			CHECKED			STATUS OF DRAWING
								APPROVED







EXECUTION-I (CARBON STEEL)

POS No.	DESCRIPTION	DIMENSION	MATERIAL	CODE	QTY
1	PIPE	OD17xTHK1.7	A312-TP321	AA1071155652	300mm
2	FLAT SEALING	ø20	ALUMINIUM	HY7161094828	2
3	PRESSURE GAUGE VALVE (ND 250)	M20x1.5	A182-F316	AA7316402202	1
4	SLIDING NUT	M20x1.5	C40N	HY7316661054	1
5	ADAPTOR	1/2"NPT-F/ M20x1.5-M	STAINLESS STEEL	TC9756219025	1
6	NIPPLE	20A	C40N	HY7316662034	1
7	DILO PARALLEL MALE COUPLING	R1/2"	CS WITH SS ENDS	TC9756106069	1

BILL OF MATERIAL FOR SHEET 10

THE INFORMATION ON THIS DOCUMENT IS THE PROPERTY OF BHARAT HEAVY ELECTRICALS LIMITED. IT MUST NOT BE USED DIRECTLY OR INDIRECTLY IN ANY WAY DETRIMENTAL TO THE INTEREST OF THE COMPANY.

REF. DRG. NO. COMPUTER NO.  
HOOKUP1.DWGSIGN. & DATE  
INVENTORY NO.

ITEM NO.	DESCRIPTION.	DRAWING NO.	MATL. CODE	GROSS WT																																																																
			MATL. SPECN.	QTY.																																																																
<table border="1"> <tr> <td rowspan="3">  </td> <td colspan="2">BHARAT HEAVY ELECTRICALS LTD. HYDERABAD</td> <td>NAME</td> <td>SIGN</td> <td>DATE</td> <td rowspan="3">NO.OF VAR.</td> </tr> <tr> <td>DRN.</td> <td>R.BIJU</td> <td>-SD-</td> <td>18.11.93</td> <td>-NA-</td> </tr> <tr> <td>CKD.</td> <td>G.R.REDDY</td> <td>-SD-</td> <td>18.12.93</td> <td>-NA-</td> </tr> <tr> <td></td> <td></td> <td></td> <td>APPD.</td> <td>G.R.REDDY</td> <td>-SD-</td> <td>18.12.93</td> <td>-NA-</td> </tr> <tr> <td>DEPT.</td> <td>T.C.E.I</td> <td rowspan="2">  </td> <td>SCALE</td> <td>WEIGHT(K.G.)</td> <td>REF.TO ASSY.DRG.</td> <td>ITEM NO.</td> <td>NO.OF ITEM</td> </tr> <tr> <td>CODE</td> <td>415</td> <td>-NA-</td> <td>-NA-</td> <td>-NA-</td> <td>-NA-</td> <td>-NA-</td> </tr> <tr> <td colspan="3">TITLE</td> <td colspan="3">DRAWING NO.</td> <td>REV.</td> <td></td> </tr> <tr> <td colspan="3">BILL OF MATERIAL FOR SHEET 10</td> <td colspan="3">4-312-00-50126</td> <td>00</td> <td></td> </tr> <tr> <td colspan="3"></td> <td>SHT.NO. 11</td> <td colspan="3">NO.OF SHT. 44</td> <td></td> </tr> </table>						BHARAT HEAVY ELECTRICALS LTD. HYDERABAD		NAME	SIGN	DATE	NO.OF VAR.	DRN.	R.BIJU	-SD-	18.11.93	-NA-	CKD.	G.R.REDDY	-SD-	18.12.93	-NA-				APPD.	G.R.REDDY	-SD-	18.12.93	-NA-	DEPT.	T.C.E.I		SCALE	WEIGHT(K.G.)	REF.TO ASSY.DRG.	ITEM NO.	NO.OF ITEM	CODE	415	-NA-	-NA-	-NA-	-NA-	-NA-	TITLE			DRAWING NO.			REV.		BILL OF MATERIAL FOR SHEET 10			4-312-00-50126			00					SHT.NO. 11	NO.OF SHT. 44			
	BHARAT HEAVY ELECTRICALS LTD. HYDERABAD		NAME	SIGN		DATE	NO.OF VAR.																																																													
	DRN.	R.BIJU	-SD-	18.11.93		-NA-																																																														
	CKD.	G.R.REDDY	-SD-	18.12.93	-NA-																																																															
			APPD.	G.R.REDDY	-SD-	18.12.93	-NA-																																																													
DEPT.	T.C.E.I		SCALE	WEIGHT(K.G.)	REF.TO ASSY.DRG.	ITEM NO.	NO.OF ITEM																																																													
CODE	415		-NA-	-NA-	-NA-	-NA-	-NA-																																																													
TITLE			DRAWING NO.			REV.																																																														
BILL OF MATERIAL FOR SHEET 10			4-312-00-50126			00																																																														
			SHT.NO. 11	NO.OF SHT. 44																																																																

FIRST ANGLE PROJECTION

ALL DIMENSIONS ARE IN mm.

REV.	DATE	ALTERED	REV.	DATE	ALTERED	REV.	DATE	ADDITIONAL INFORMATION
		CHECKED			CHECKED			STATUS OF DRAWING
								APPROVED

THE INFORMATION ON THIS DOCUMENT IS THE PROPERTY OF BHARAT HEAVY ELECTRICALS LIMITED. IT MUST NOT BE USED DIRECTLY OR INDIRECTLY IN ANY WAY DETRIMENTAL TO THE INTEREST OF THE COMPANY.

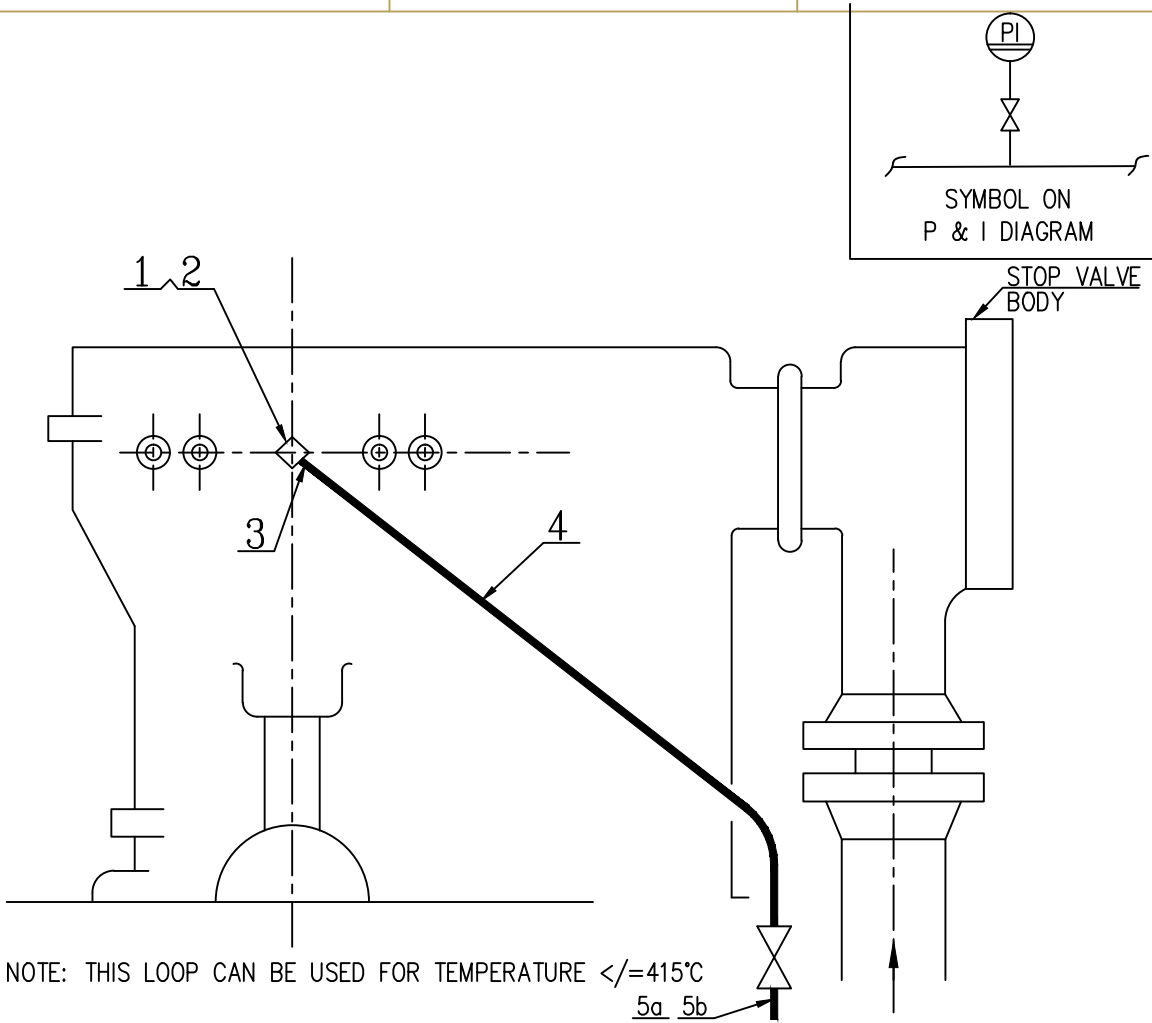

NOTE: THIS LOOP CAN BE USED FOR TEMPERATURE  $\leq 415^{\circ}\text{C}$   
5a 5b

ITEM NO.	DESCRIPTION.	DRAWING NO.	MATL. CODE	GROSS WT
			MATL. SPECN.	QTY.

BHARAT HEAVY ELECTRICALS LTD. HYDERABAD	DRN.	R.BIJU	-SD-	18.11.93	NO.OF VAR.		
	CKD.	G.R.REDDY	-SD-	18.12.93	-NA-		
	APPD.	G.R.REDDY	-SD-	18.12.93	-NA-		
DEPT.	T.C.E.I		SCALE	WEIGHT(K.G.)	REF.TO ASSY.DRG.	ITEM NO.	NO.OF ITEM
CODE	415		-NA-	-NA-	-NA-	-NA-	-NA-
TITLE			PRESSURE GAUGE CONNECTION		DRAWING NO.		REV.
			WHEEL CHAMBER		4-312-00-50126		00
			(ANSI RATINGS 300,600,1500)		SHT.NO. 12		NO.OF SHT. 44

FIRST ANGLE PROJECTION

ALL DIMENSIONS ARE IN mm.

REV.	DATE	ALTERED	REV.	DATE	ALTERED	REV.	DATE	ADDITIONAL INFORMATION
		CHECKED			CHECKED			STATUS OF DRAWING
								APPROVED

THE INFORMATION ON THIS DOCUMENT IS THE PROPERTY OF BHARAT HEAVY ELECTRICALS LIMITED. IT MUST NOT BE USED DIRECTLY OR INDIRECTLY IN ANY WAY DETRIMENTAL TO THE INTEREST OF THE COMPANY.



POS No.	DESCRIPTION	DIMENSION	MATERIAL	CODE	QTY		
					#300	#600	#1500
1	WASHER	∅21x27x1.5	ALUMINIUM	HY7161094259	1	1	1
2	ANGLE CONN. PIECE	M20x1.5(M) 1/2"NPT-F	21CrMoV57V	TC9755402012	1	1	1
3	NIPPLE	1/2"SCH80 NPT/BW	SA 106/B	HY7242578116	1	1	1
4	PIPE	1/2"SCH 80	SA 106/B	AA1049355083	1	1	1
5a	GATE VALVE	1/2"800 SW	A 105	AA7521468589	1	1	1
5b	GLOBE VALVE	1/2"1500 SW	A 105	AA7501508585			1

BILL OF MATERIAL FOR SHEET 12

REF. DRG. NO. COMPUTER NO.  
HOOKUP13.DWG

SIGN. & DATE  
INVENTORY NO.

ITEM NO.	DESCRIPTION.	DRAWING NO.	MATL. CODE	GROSS WT
			MATL. SPECN.	QTY.

 BHARAT HEAVY ELECTRICALS LTD. HYDERABAD	DRN.	R.BIJU	-SD-	18.11.93	NO.OF VAR.
	CKD.	G.R.REDDY	-SD-	18.12.93	-NA-
	APPD.	G.R.REDDY	-SD-	18.12.93	-NA-
DEPT. T.C.E.I		SCALE	WEIGHT(K.G.)	REF.TO ASSY.DRG.	ITEM NO.
CODE 415		-NA-	-NA-	-NA-	-NA-
TITLE				DRAWING NO.	REV.
BILL OF MATERIAL FOR SHEET 12				4-312-00-50126	00
				SHT.NO. 13	NO.OF SHT. 44

FIRST ANGLE PROJECTION

ALL DIMENSIONS ARE IN mm.

REV.	DATE	ALTERED	REV.	DATE	ALTERED	REV.	DATE	ADDITIONAL INFORMATION
		CHECKED			CHECKED			STATUS OF DRAWING
								APPROVED

THE INFORMATION ON THIS DOCUMENT IS THE PROPERTY OF BHARAT HEAVY ELECTRICALS LIMITED. IT MUST NOT BE USED DIRECTLY OR INDIRECTLY IN ANY WAY DETRIMENTAL TO THE INTEREST OF THE COMPANY.

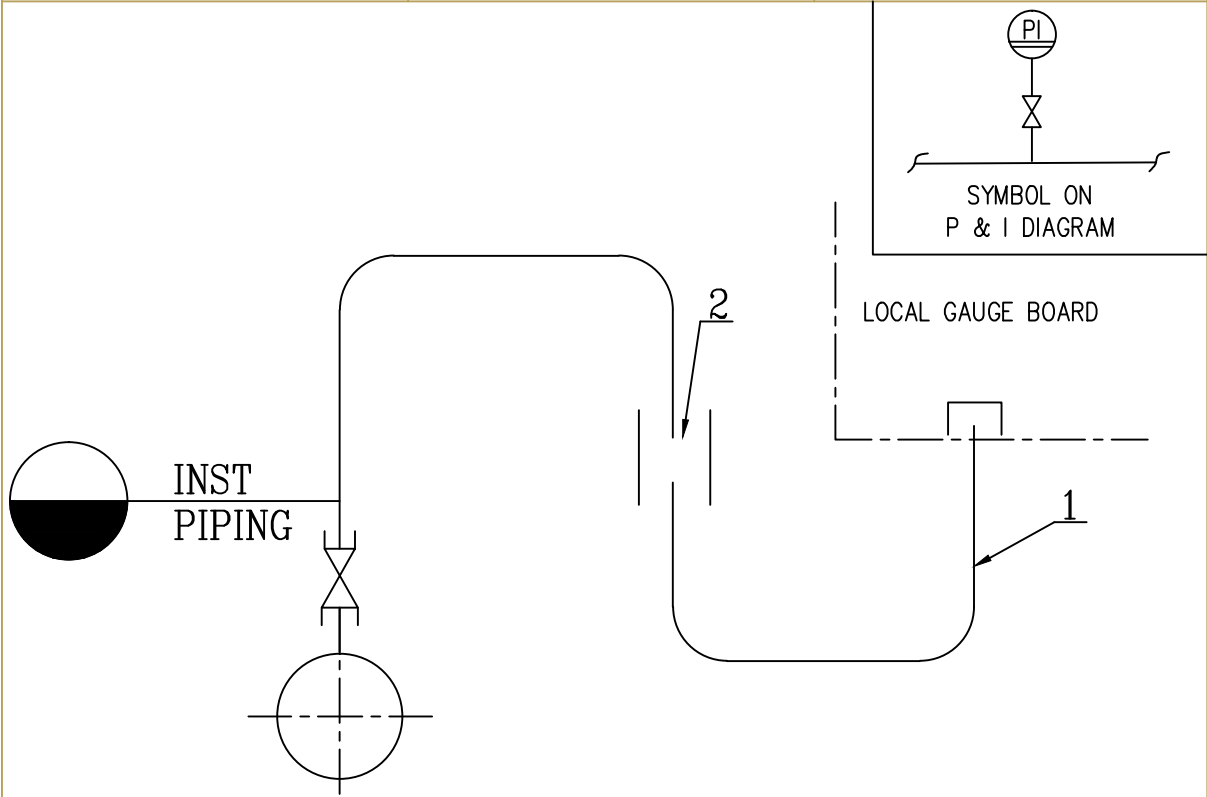



POS No.	DESCRIPTION	DIMENSION	MATERIAL	CODE	QTY
1	PIPE	1/2" SCH 80	SA335 GYP22	AA1069330086	15M
2	COUPLING	1/2"-6000SW	SA182 F22	AA7242520401	2

NOTE: THIS LOOP CAN BE USED FOR TEMPERATURE BETWEEN 415°C & 550°C

REF. DRG. NO. COMPUTER NO. HOOKUP14.DWG

SIGN. & DATE INVENTORY NO.

ITEM NO.	DESCRIPTION.	DRAWING NO.	MATL. CODE	GROSS WT
			MATL. SPECN.	QTY.

 BHARAT HEAVY ELECTRICALS LTD. HYDERABAD	DRN.	R.BIJU	-SD-	18.11.93	NO.OF VAR. -NA-		
	CKD.	G.R.REDDY	-SD-	18.12.93			
	APPD.	G.R.REDDY	-SD-	18.12.93			
DEPT.	T.C.E.I		SCALE	WEIGHT(K.G.)	REF.TO ASSY.DRG.	ITEM NO.	NO.OF ITEM
CODE	415		-NA-	-NA-	-NA-	-NA-	-NA-
TITLE					DRAWING NO.	REV.	
PRESSURE GAUGE CONNECTION LGB INSTRUMENTS (STEAM SERVICE) (ANSI RATINGS 2500)					4-312-00-50126	00	
				SHT.NO. 14	NO.OF SHT. 44		

FIRST ANGLE PROJECTION

ALL DIMENSIONS ARE IN mm.

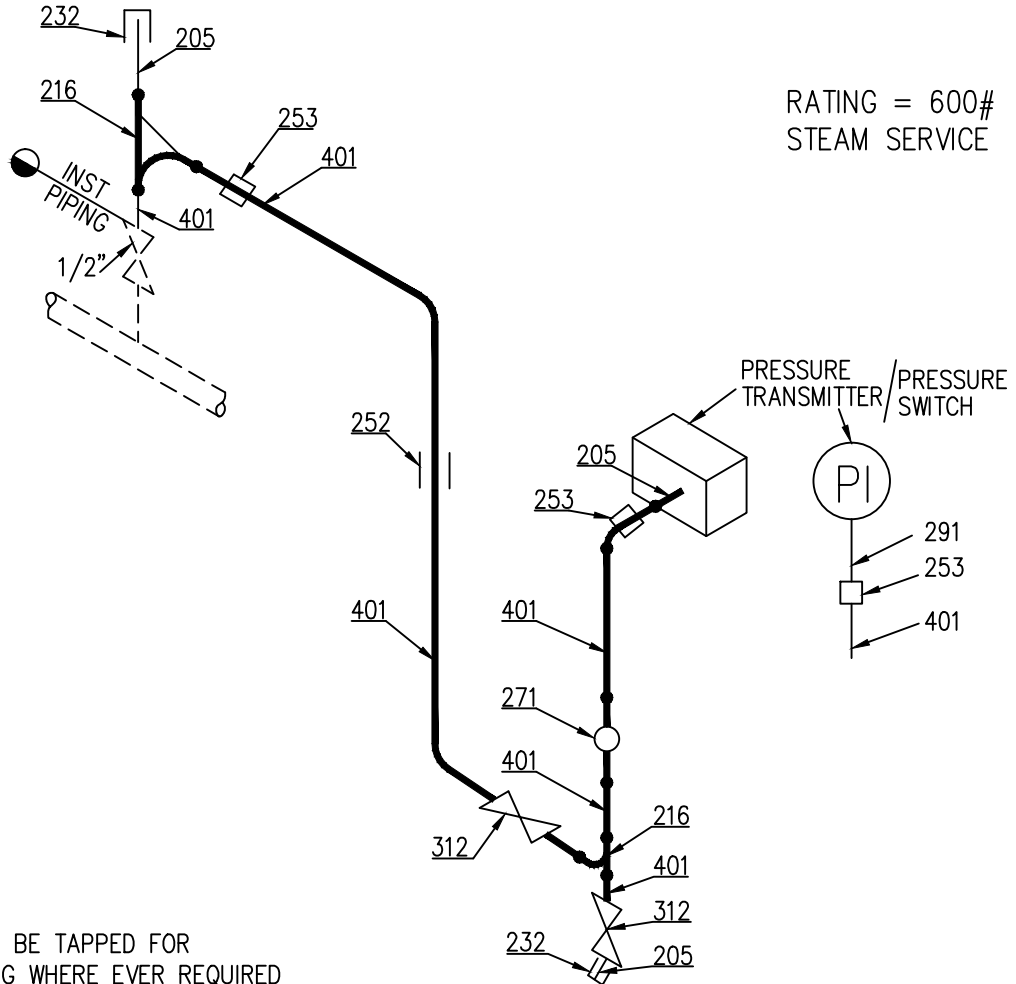

REV.	DATE	ALTERED	REV.	DATE	ALTERED	REV.	DATE	ADDITIONAL INFORMATION
		CHECKED			CHECKED			STATUS OF DRAWING
								APPROVED

THE INFORMATION ON THIS DOCUMENT IS THE PROPERTY OF BHARAT HEAVY ELECTRICALS LIMITED. IT MUST NOT BE USED DIRECTLY OR INDIRECTLY IN ANY WAY DETRIMENTAL TO THE INTEREST OF THE COMPANY.



**NOTE:**  
 PIPE CAN BE TAPPED FOR THREADING WHERE EVER REQUIRED

REF. DRG. NO.	COMPUTER NO.			
HOOKUP15.DWG				
ITEM NO.	DESCRIPTION.	DRAWING NO.	MATL. CODE	GROSS WT
			MATL. SPECN.	QTY.

 BHARAT HEAVY ELECTRICALS LTD. HYDERABAD	DRN.	R.BIJU	-SD-	18.11.93	NO.OF VAR.		
	CKD.	G.R.REDDY	-SD-	18.12.93	-NA-		
	APPD.	G.R.REDDY	-SD-	18.12.93	-NA-		
DEPT.	T.C.E.I		SCALE	WEIGHT(K.G.)	REF.TO ASSY.DRG.	ITEM NO.	NO.OF ITEM
CODE	415		-NA-	-NA-	-NA-	-NA-	-NA-
TITLE PRESSURE GAUGE CONNECTION (METER BELOW) STEAM SERVICE					DRAWING NO. 4-312-00-50126		REV. 00
			SHT.NO. 15	NO.OF SHT. 44			

FIRST ANGLE PROJECTION

ALL DIMENSIONS ARE IN mm.

REV.	DATE	ALTERED	REV.	DATE	ALTERED	REV.	DATE	ADDITIONAL INFORMATION
		CHECKED			CHECKED			STATUS OF DRAWING
								APPROVED



THE INFORMATION ON THIS DOCUMENT IS THE PROPERTY OF BHARAT HEAVY ELECTRICALS LIMITED. IT MUST NOT BE USED DIRECTLY OR INDIRECTLY IN ANY WAY DETRIMENTAL TO THE INTEREST OF THE COMPANY.

POS No.	DESCRIPTION	MATERIAL	QTY	MATERIAL CODE
401	PIPE DIA 1/2" SCH 80 ø21.3x3.7	A106 B	15M	AA1049355083
252	COUPLING ø1/2" SW-F	A105	2	AA7242520045
216	T-UNION ø1/2" SW-F	A105	2	AA7242510040
205	NIPPLE ø1/2" BW/NPTM	A106 Gr B	3	HY7242578043
232	CAP ø1/2" NPT-F	A105	2	HY7242579040
312	GLOBE VALVE ø1/2"SW	A105	2	AA7501508585
271	SYPHON 80S BW ø1/2"BW-M	A105	1	HY7316201622
291	ADAPTOR ø1/2BW 1/2NPTM (FOR PRESS GAUGES)	A105	1	TC9755411020
253	DILO COUPLING 1/2"-3000	A105	2	TC9756105038

REF. DRG. NO. COMPUTER NO.  
HOOKUP16.DWG

ITEM NO.	DESCRIPTION.	DRAWING NO.	MATL. CODE	GROSS WT
			MATL. SPECN.	QTY.

SIGN. & DATE  
INVENTORY NO.

 BHARAT HEAVY ELECTRICALS LTD. HYDERABAD	DRN.	R.BIJU	-SD-	18.11.93	NO.OF VAR.
	CKD.	G.R.REDDY	-SD-	18.12.93	-NA-
	APPD.	G.R.REDDY	-SD-	18.12.93	-NA-
DEPT. T.C.E.I		SCALE -NA-	WEIGHT(K.G.) -NA-	REF.TO ASSY.DRG. -NA-	ITEM NO. -NA-
CODE 415					
TITLE				DRAWING NO.	REV.
BILL OF MATERIAL FOR SHEET 15				4-312-00-50126	00
				SHT.NO. 16	NO.OF SHT. 44

FIRST ANGLE PROJECTION

ALL DIMENSIONS ARE IN mm.

REV.	DATE	ALTERED	REV.	DATE	ALTERED	REV.	DATE	ADDITIONAL INFORMATION
		CHECKED			CHECKED			STATUS OF DRAWING
								APPROVED

RATING = 600#  
STEAM SERVICE

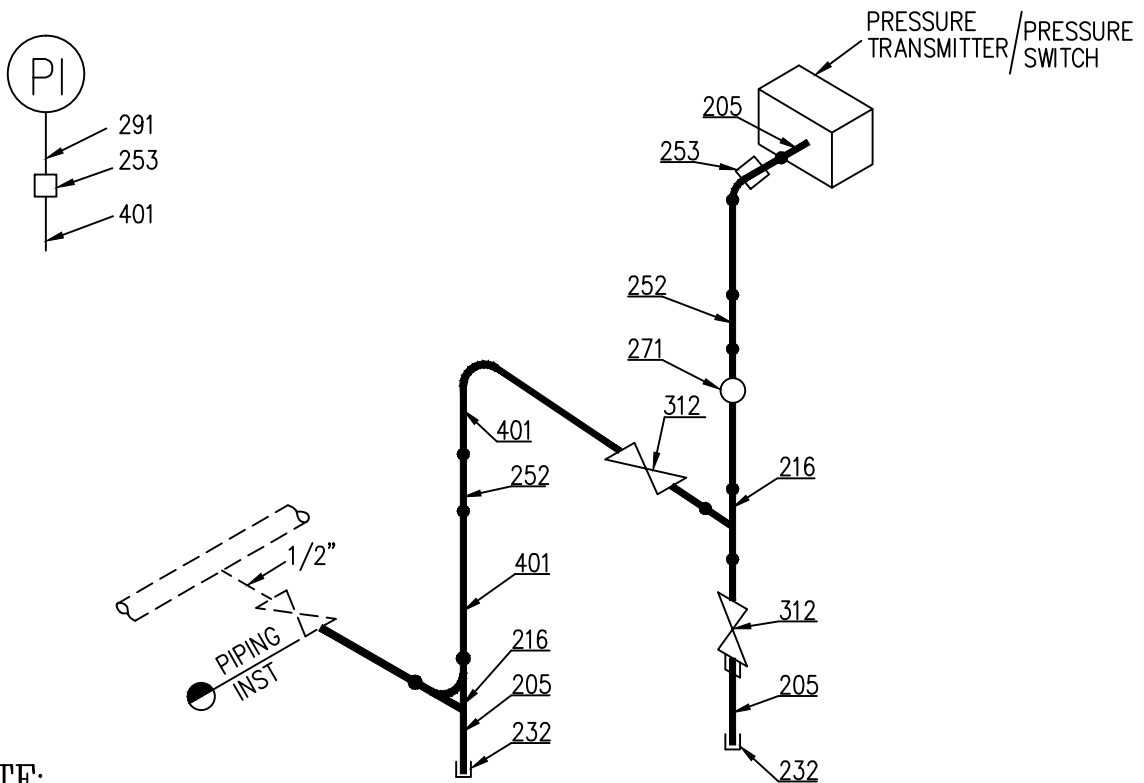

**NOTE:**



PIPE CAN BE TAPPED FOR  
THREADING WHERE EVER REQUIRED

THE INFORMATION ON THIS DOCUMENT IS THE PROPERTY OF BHARAT HEAVY ELECTRICALS LIMITED. IT MUST NOT BE USED DIRECTLY OR INDIRECTLY IN ANY WAY DETRIMENTAL TO THE INTEREST OF THE COMPANY.

REF. DRG. NO. COMPUTER NO. HOOKUP17.DWG

SIGN. & DATE INVENTORY NO.

ITEM NO.	DESCRIPTION.	DRAWING NO.	MATL. CODE	GROSS WT
			MATL. SPECN.	QTY.

 BHARAT HEAVY ELECTRICALS LTD. HYDERABAD	DRN.	R.BIJU	-SD-	18.11.93	NO.OF VAR.		
	CKD.	G.R.REDDY	-SD-	18.12.93	-NA-		
	APPD.	G.R.REDDY	-SD-	18.12.93	-NA-		
DEPT.	T.C.E.I		SCALE	WEIGHT(K.G.)	REF.TO ASSY.DRG.	ITEM NO.	NO.OF ITEM
CODE	415		-NA-	-NA-	-NA-	-NA-	-NA-
TITLE			DRAWING NO.		REV.		
PRESSURE INST. CONNECTION (METER ABOVE) STEAM SERVICE			4-312-00-50126		00		
			SHT.NO. 17	NO.OF SHT. 44			

FIRST ANGLE PROJECTION

ALL DIMENSIONS ARE IN mm.

REV.	DATE	ALTERED	REV.	DATE	ALTERED	REV.	DATE	ADDITIONAL INFORMATION
		CHECKED			CHECKED			STATUS OF DRAWING
								APPROVED



THE INFORMATION ON THIS DOCUMENT IS THE PROPERTY OF BHARAT HEAVY ELECTRICALS LIMITED. IT MUST NOT BE USED DIRECTLY OR INDIRECTLY IN ANY WAY DETRIMENTAL TO THE INTEREST OF THE COMPANY.

POS No.	DESCRIPTION	MATERIAL	QTY	MATERIAL CODE
401	PIPE DIA 1/2" SCH 80 ø21.3x3.7	A106 B	15M	AA1049355083
252	COUPLING ø1/2" SW-F	A105	2	AA7242520045
216	T-UNION ø1/2" SW-F	A105	2	AA7242510040
205	NIPPLE ø1/2" BW/NPTM	A106 Gr B	2	HY7242578043
232	CAP ø1/2" NPT-F	A105	2	HY7242579040
312	GLOBE VALVE ø1/2"SW	A105	2	AA7501508585
271	SYPHON 80S BW ø1/2"BW-M	A105	1	HY7316201622
291	ADAPTOR ø1/2BW 1/2NPTM	A105	1	TC9755411020
253	DILO COUPLING 1/2"-3000	SS316	2	TC9756105046

REF. DRG. NO. COMPUTER NO.  
HOOKUP18.DWG

ITEM NO.	DESCRIPTION.	DRAWING NO.	MATL. CODE	GROSS WT
			MATL. SPECN.	QTY.

SIGN. & DATE  
INVENTORY NO.

 BHARAT HEAVY ELECTRICALS LTD. HYDERABAD	DRN.	R.BIJU	-SD-	18.11.93	NO.OF VAR.
	CKD.	G.R.REDDY	-SD-	18.12.93	-NA-
	APPD.	G.R.REDDY	-SD-	18.12.93	-NA-
DEPT. T.C.E.I		SCALE	WEIGHT(K.G.)	REF.TO ASSY.DRG.	ITEM NO.
CODE 415		-NA-	-NA-	-NA-	-NA-
TITLE				DRAWING NO.	REV.
BILL OF MATERIAL FOR SHEET 17				4-312-00-50126	00
				SHT.NO. 18	NO.OF SHT. 44

FIRST ANGLE PROJECTION



ALL DIMENSIONS ARE IN mm.

REV.	DATE	ALTERED	REV.	DATE	ALTERED	REV.	DATE	ADDITIONAL INFORMATION
		CHECKED			CHECKED			STATUS OF DRAWING
								APPROVED

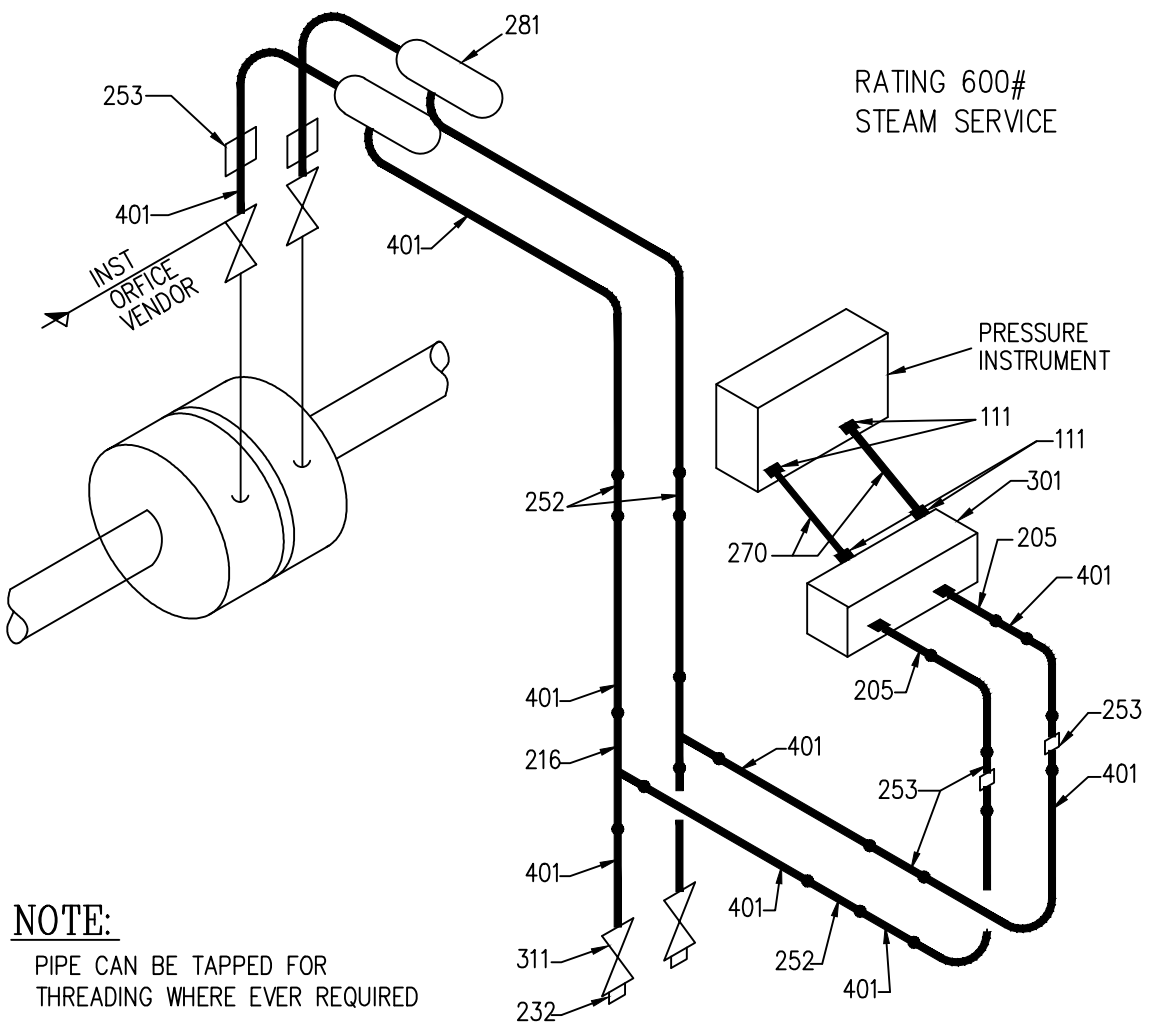
REF. DRG. NO. COMPUTER NO. HOOKUP19.DWG  
 SIGN. & DATE  
 INVENTORY NO.



ITEM NO.	DESCRIPTION.	DRAWING NO.	MATL. CODE	GROSS WT
			MATL. SPECN.	QTY.

 BHARAT HEAVY ELECTRICALS LTD. HYDERABAD	DRN.	R.BIJU	-SD-	18.11.93	NO.OF VAR.		
	CKD.	G.R.REDDY	-SD-	18.12.93	-NA-		
	APPD.	G.R.REDDY	-SD-	18.12.93	-NA-		
DEPT.	T.C.E.I		SCALE	WEIGHT(K.G.)	REF.TO ASSY.DRG.	ITEM NO.	NO.OF ITEM
CODE	415		-NA-	-NA-	-NA-	-NA-	-NA-
TITLE			DRAWING NO.		REV.		
FLOW INSTRUMENT-DPT (METER BELOW) STEAM SERVICE			4-312-00-50126		00		
			SHT.NO.	19	NO.OF SHT.	44	

FIRST ANGLE PROJECTION

ALL DIMENSIONS ARE IN mm.

REV.	DATE	ALTERED	REV.	DATE	ALTERED	REV.	DATE	ADDITIONAL INFORMATION
		CHECKED			CHECKED			STATUS OF DRAWING
								APPROVED



THE INFORMATION ON THIS DOCUMENT IS THE PROPERTY OF BHARAT HEAVY ELECTRICALS LIMITED. IT MUST NOT BE USED DIRECTLY OR INDIRECTLY IN ANY WAY DETRIMENTAL TO THE INTEREST OF THE COMPANY.

POS No.	DESCRIPTION	MATERIAL	QTY	MATERIAL CODE
401	PIPE DIA 1/2" SCH 80 ø21.3x3.7	A106 B	30M	AA1049355083
252	COUPLING ø1/2" SW-F	A105	4	AA7242520045
216	T-UNION ø1/2" SW-F	A105	4	AA7242510040
205	NIPPLE ø1/2" BW/NPTM	A106 Gr B	6	HY7242578043
232	CAP ø1/2" NPT-F	A105	4	HY7242579040
311	GLOBE VALVE ø1/2"SW	AA105	2	AA7501508585
301	5 WAY MANIFOLD ø1/2"NPT-F	AA105	1	HY7316561017
281	CONDENSATE POT ø1/2"SW-F	SS316	2	TC9755535047
253	DILO COUPLING 1/2"-3000	SS316	4	TC9756105046
270	SS TUBE OD-12.7MM t=2.1MM	SS316	6M	HY1071090054
111	MALE CONNECTOR ø1/2"NPT-M TO 12.7mm SS TUBE (3000)	SS316	4	GT9754229074

REF. DRG. NO. COMPUTER NO.  
HOOKUP20.DWG

ITEM NO.	DESCRIPTION.	DRAWING NO.	MATL. CODE	GROSS WT
			MATL. SPECN.	QTY.

SIGN. & DATE  
INVENTORY NO.

 BHARAT HEAVY ELECTRICALS LTD. HYDERABAD	DRN.	R.BIJU	-SD-	18.11.93	NO.OF VAR.
	CKD.	G.R.REDDY	-SD-	18.12.93	-NA-
	APPD.	G.R.REDDY	-SD-	18.12.93	-NA-
DEPT. T.C.E.I		SCALE	WEIGHT(K.G.)	REF.TO ASSY.DRG.	ITEM NO.
CODE 415		-NA-	-NA-	-NA-	-NA-
TITLE				DRAWING NO.	REV.
BILL OF MATERIAL FOR SHEET 19				4-312-00-50126	00
			SHT.NO. 20	NO.OF SHT. 44	

FIRST ANGLE PROJECTION

ALL DIMENSIONS ARE IN mm.

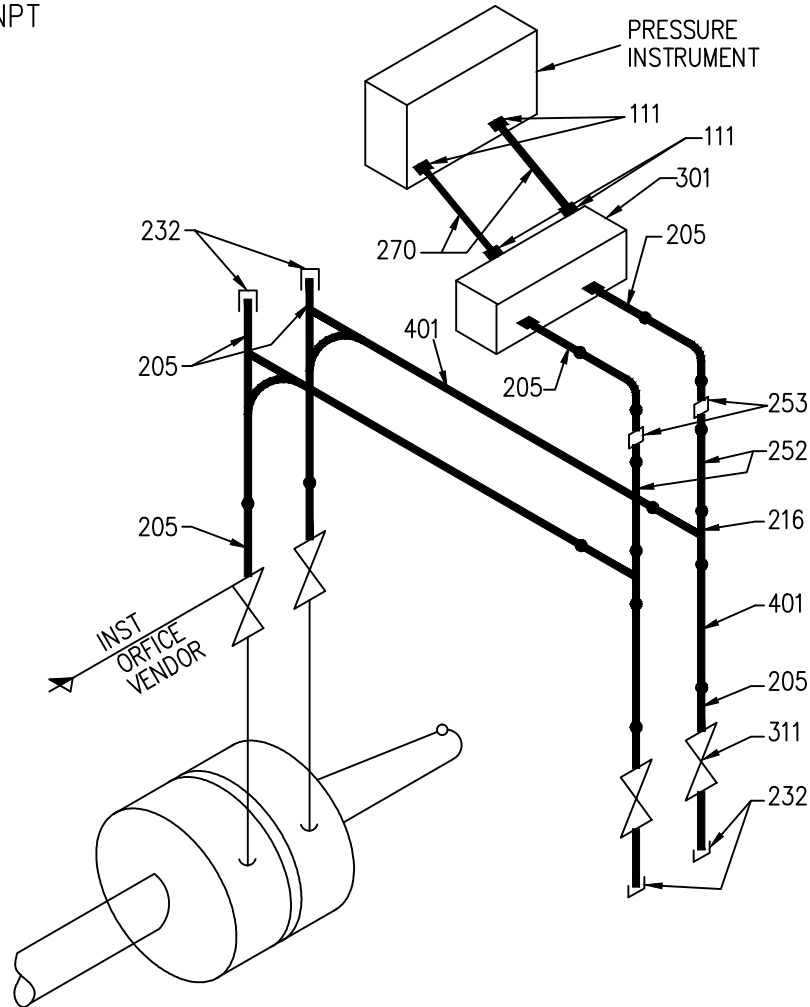

REV.	DATE	ALTERED	REV.	DATE	ALTERED	REV.	DATE	ADDITIONAL INFORMATION
		CHECKED			CHECKED			STATUS OF DRAWING
								APPROVED

RATING 600# NPT



REF. DRG. NO. COMPUTER NO. HOOKUP21.DWG  
 SIGN. & DATE  
 INVENTORY NO.  
 THE INFORMATION ON THIS DOCUMENT IS THE PROPERTY OF BHARAT HEAVY ELECTRICALS LIMITED. IT MUST NOT BE USED DIRECTLY OR INDIRECTLY IN ANY WAY DETRIMENTAL TO THE INTEREST OF THE COMPANY.

ITEM NO.	DESCRIPTION.	DRAWING NO.	MATL. CODE	GROSS WT
			MATL. SPECN.	QTY.

 BHARAT HEAVY ELECTRICALS LTD. HYDERABAD	DRN.	R.BIJU	-SD-	18.11.93	NO.OF VAR.	
	CKD.	G.R.REDDY	-SD-	18.12.93	-NA-	
	APPD.	G.R.REDDY	-SD-	18.12.93	-NA-	
DEPT. T.C.E.I		SCALE	WEIGHT(K.G.)	REF.TO ASSY.DRG.	ITEM NO.	NO.OF ITEM
CODE 415		-NA-	-NA-	-NA-	-NA-	-NA-
TITLE				DRAWING NO.	REV.	
FLOW INSTRUMENT-DPT				4-312-00-50126	00	
WATER & GAS SERVICE (METER ABOVE)				SHT.NO. 21	NO.OF SHT. 44	

FIRST ANGLE PROJECTION

ALL DIMENSIONS ARE IN mm.

REV.	DATE	ALTERED	REV.	DATE	ALTERED	REV.	DATE	ADDITIONAL INFORMATION
		CHECKED			CHECKED			STATUS OF DRAWING
								APPROVED



THE INFORMATION ON THIS DOCUMENT IS THE PROPERTY OF BHARAT HEAVY ELECTRICALS LIMITED. IT MUST NOT BE USED DIRECTLY OR INDIRECTLY IN ANY WAY DETRIMENTAL TO THE INTEREST OF THE COMPANY.

POS No.	DESCRIPTION	MATERIAL	QTY	MATERIAL CODE
401	PIPE DIA 1/2" SCH 80 ø21.3x3.7	A106 B	15M	AA1049355083
252	COUPLING ø1/2" SW-F	A105	4	AA7242520045
216	T-UNION ø1/2" SW-F	A105	4	AA7242510040
205	NIPPLE ø1/2" BW/NPTM	A106 Gr B	6	HY7242578043
232	CAP ø1/2" NPT-F	A105	4	HY7242579040
311	GLOBE VALVE ø1/2"SW-F	AA105	2	AA7501508585
301	5 WAY MANIFOLD ø1/2"NPT-F	SS316	1	HY7316561017
281	CONDENSATE POT ø1/2"SW-F	SS316	2	TC9755535047
253	DILO COUPLING 1/2"-3000	SS316	4	TC9756105046
111	MALE CONNECTOR ø1/2"NPT-M TO 12.7mm SS TUBE	SS316	4	GT9754229074
270	SS TUBE OD-12.7MM t=2.1MM	SS316	6M	HY1071090054

REF. DRG. NO. COMPUTER NO.  
HOOKUP22.DWG

ITEM NO.	DESCRIPTION.	DRAWING NO.	MATL. CODE	GROSS WT
			MATL. SPECN.	QTY.

SIGN. & DATE  
INVENTORY NO.

 BHARAT HEAVY ELECTRICALS LTD. HYDERABAD	DRN.	R.BIJU	-SD-	18.11.93	NO.OF VAR.
	CKD.	G.R.REDDY	-SD-	18.12.93	-NA-
	APPD.	G.R.REDDY	-SD-	18.12.93	-NA-
DEPT. T.C.E.I		SCALE	WEIGHT(K.G.)	REF.TO ASSY.DRG.	ITEM NO.
CODE 415		-NA-	-NA-	-NA-	-NA-
TITLE				DRAWING NO.	REV.
BILL OF MATERIAL FOR SHEET 21				4-312-00-50126	00
			SHT.NO. 22	NO.OF SHT. 44	

FIRST ANGLE PROJECTION



ALL DIMENSIONS ARE IN mm.

REV.	DATE	ALTERED	REV.	DATE	ALTERED	REV.	DATE	ADDITIONAL INFORMATION
		CHECKED			CHECKED			STATUS OF DRAWING
								APPROVED

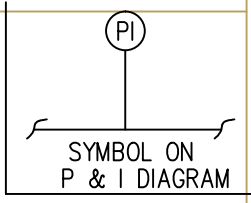
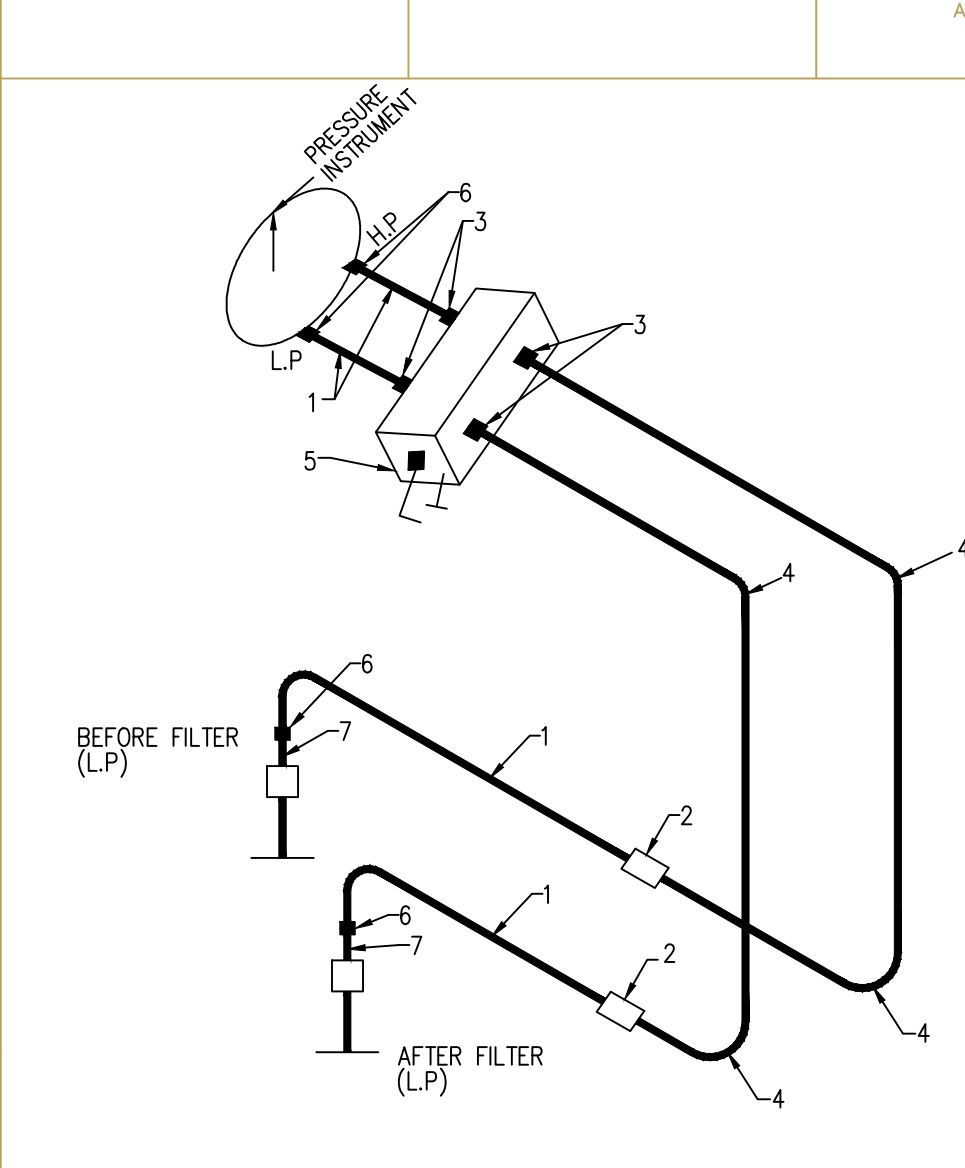
REF. DRG. NO. COMPUTER NO. HOOKUP23.DWG  
 SIGN. & DATE  
 INVENTORY NO.



ITEM NO.	DESCRIPTION.	DRAWING NO.	MATL. CODE	GROSS WT
			MATL. SPECN.	QTY.

 BHARAT HEAVY ELECTRICALS LTD. HYDERABAD	DRN.	R.BIJU	-SD-	18.11.93	NO.OF VAR.
	CKD.	G.R.REDDY	-SD-	18.12.93	-NA-
	APPD.	G.R.REDDY	-SD-	18.12.93	-NA-
DEPT. T.C.E.I	 SCALE -NA- WEIGHT(K.G.) -NA-	REF.TO ASSY.DRG.	ITEM NO.	NO.OF ITEM	
CODE 415		-NA-	-NA-	-NA-	
TITLE		DRAWING NO.		REV.	
DIFFERENTIAL PRESSURE INDICATOR (COMMON TAPPING FOR DPS & DPI)		4-312-00-50126		00	
		SHT.NO. 23	NO.OF SHT. 44		

FIRST ANGLE PROJECTION

ALL DIMENSIONS ARE IN mm.

REV.	DATE	ALTERED	REV.	DATE	ALTERED	REV.	DATE	ADDITIONAL INFORMATION
		CHECKED			CHECKED			STATUS OF DRAWING
								APPROVED



THE INFORMATION ON THIS DOCUMENT IS THE PROPERTY OF BHARAT HEAVY ELECTRICALS LIMITED. IT MUST NOT BE USED DIRECTLY OR INDIRECTLY IN ANY WAY DETRIMENTAL TO THE INTEREST OF THE COMPANY.

POS No.	DESCRIPTION	MATERIAL	QTY	MATERIAL CODE
1	SS TUBE OD=12.7mm t=2.1mm	SS316	15M	HY1071090054
2	STRAIGHT UNION (FRACTIONAL TUBE TO FRACTIONAL TUBE)	SS-810-6	2	GT9754229015
3	1/2" NPT-M CONNECTOR	SS-810-1-8	6	GT9754229074
4	MALE ELBOW	SS-810-2-8	4	GT9754229031
5	5 WAY MANIFOLD 1/2" NPT-F	SS316	1	HY7316561017
6	FEMALE CONNECTOR 1/2" NPT-F TO SS TUBE 12.7mm OD	SS316	2	GT9754229988
7	NIPPLE $\phi$ 1/2" BW/NPTM	SS316	2	HY7242578841

REF. DRG. NO. COMPUTER NO.  
HOOKUP24.DWG

ITEM NO.	DESCRIPTION.	DRAWING NO.	MATL. CODE	GROSS WT
			MATL. SPECN.	QTY.

SIGN. & DATE  
INVENTORY NO.

 BHARAT HEAVY ELECTRICALS LTD. HYDERABAD	DRN.	R.BIJU	-SD-	18.11.93	NO.OF VAR.
	CKD.	G.R.REDDY	-SD-	18.12.93	-NA-
	APPD.	G.R.REDDY	-SD-	18.12.93	-NA-
DEPT. T.C.E.I		SCALE	WEIGHT(K.G.)	REF.TO ASSY.DRG.	ITEM NO.
CODE 415		-NA-	-NA-	-NA-	-NA-
TITLE				DRAWING NO.	REV.
BILL OF MATERIAL FOR SHEET 23				4-312-00-50126	00
				SHT.NO. 24	NO.OF SHT. 44

FIRST ANGLE PROJECTION

ALL DIMENSIONS ARE IN mm.

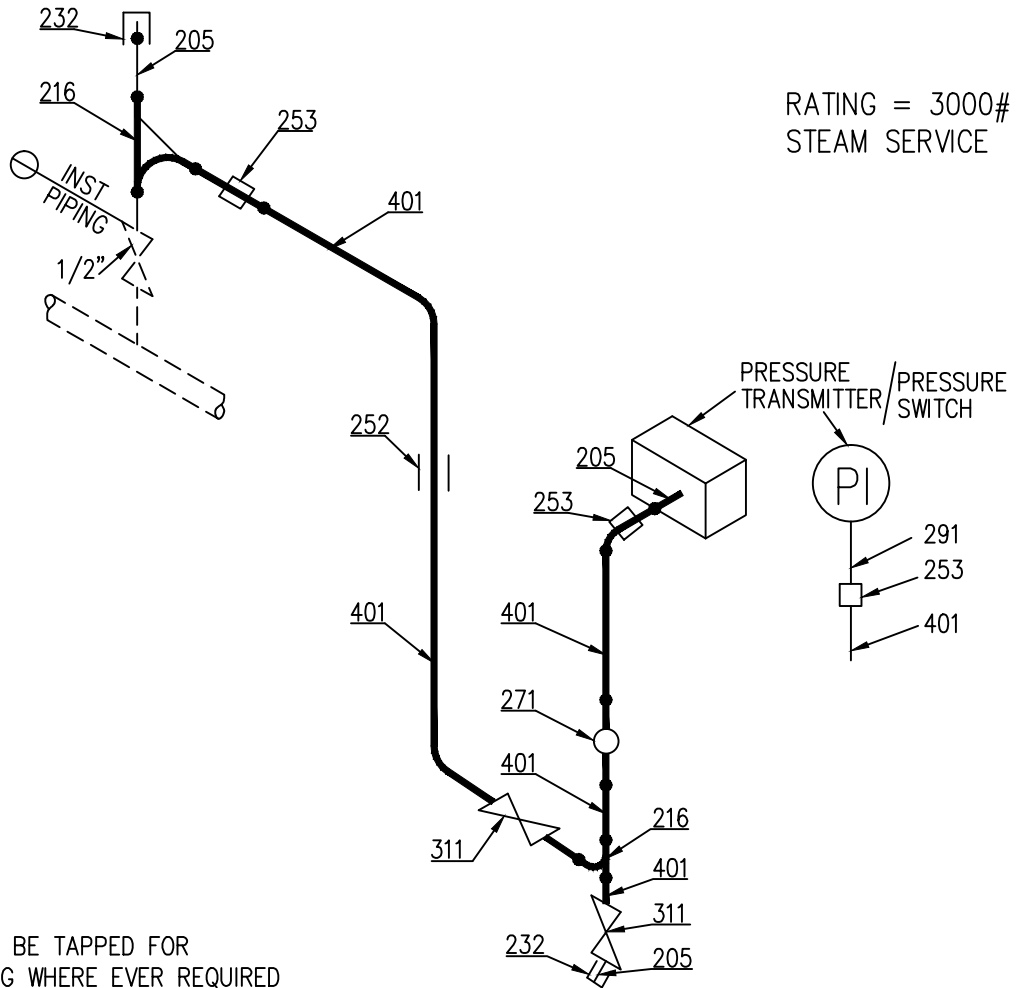

REV.	DATE	ALTERED	REV.	DATE	ALTERED	REV.	DATE	ADDITIONAL INFORMATION
		CHECKED			CHECKED			STATUS OF DRAWING
								APPROVED

THE INFORMATION ON THIS DOCUMENT IS THE PROPERTY OF BHARAT HEAVY ELECTRICALS LIMITED. IT MUST NOT BE USED DIRECTLY OR INDIRECTLY IN ANY WAY DETRIMENTAL TO THE INTEREST OF THE COMPANY.  
 REF. DRG. NO. COMPUTER NO. HOOKUP25.DWG  
 SIGN. & DATE  
 INVENTORY NO.



**NOTE:**  
 PIPE CAN BE TAPPED FOR THREADING WHERE EVER REQUIRED

ITEM NO.	DESCRIPTION.	DRAWING NO.	MATL. CODE	GROSS WT
			MATL. SPECN.	QTY.

 BHARAT HEAVY ELECTRICALS LTD. HYDERABAD	DRN.	R.BIJU	-SD-	18.11.93	NO.OF VAR.		
	CKD.	G.R.REDDY	-SD-	18.12.93	-NA-		
	APPD.	G.R.REDDY	-SD-	18.12.93	-NA-		
DEPT.	T.C.E.I		SCALE	WEIGHT(K.G.)	REF.TO ASSY.DRG.	ITEM NO.	NO.OF ITEM
CODE	415		-NA-	-NA-	-NA-	-NA-	-NA-
TITLE			DRAWING NO.		REV.		
PRESSURE GAUGE CONNECTION (METER BELOW) STEAM SERVICE			4-312-00-50126		00		
			SHT.NO.	25	NO.OF SHT.	44	

FIRST ANGLE PROJECTION

ALL DIMENSIONS ARE IN mm.

REV.	DATE	ALTERED	REV.	DATE	ALTERED	REV.	DATE	ADDITIONAL INFORMATION
		CHECKED			CHECKED			STATUS OF DRAWING
								APPROVED



THE INFORMATION ON THIS DOCUMENT IS THE PROPERTY OF BHARAT HEAVY ELECTRICALS LIMITED. IT MUST NOT BE USED DIRECTLY OR INDIRECTLY IN ANY WAY DETRIMENTAL TO THE INTEREST OF THE COMPANY.

POS No.	DESCRIPTION	MATERIAL	QTY	MATERIAL CODE
401	PIPE DIA 1/2" SCH 80 ø21.3x3.7	SA 335 GR P22	15M	AA1069330086
252	COUPLING ø1/2" SW-F,6000	SA 182 F22	4	AA7242520401
216	T-UNION ø1/2" SW-F	SA 182 F22	2	AA7242510228
205	NIPPLE ø1/2" BW/NPTM	AS	3	HY7242578647
232	CAP ø1/2" NPT	AS	2	HY7242579228
311	GLOBE VALVE ø1/2"SW-M	AS	2	AA7501534586
271	SYPHON 80S BW ø1/2"BW-M	SA 335 GR P11	1	HY7316201630
291	ADAPTOR NPT/BWF/M ø1/2" BW-F	AS	1	TC9755411038
253	DILO COUPLING 1/2"-3000	SA 182 F22	2	TC9756105046

REF. DRG. NO. COMPUTER NO.  
HOOKUP26.DWG

ITEM NO.	DESCRIPTION.	DRAWING NO.	MATL. CODE	GROSS WT
			MATL. SPECN.	QTY.

SIGN. & DATE  
INVENTORY NO.

 BHARAT HEAVY ELECTRICALS LTD. HYDERABAD	DRN.	R.BIJU	-SD-	18.11.93	NO.OF VAR.
	CKD.	G.R.REDDY	-SD-	18.12.93	-NA-
	APPD.	G.R.REDDY	-SD-	18.12.93	-NA-
DEPT. T.C.E.I		SCALE	WEIGHT(K.G.)	REF.TO ASSY.DRG.	ITEM NO.
CODE 415		-NA-	-NA-	-NA-	-NA-
TITLE				DRAWING NO.	REV.
BILL OF MATERIAL FOR SHEET 25				4-312-00-50126	00
				SHT.NO. 26	NO.OF SHT. 44

FIRST ANGLE PROJECTION

ALL DIMENSIONS ARE IN mm.

REV.	DATE	ALTERED	REV.	DATE	ALTERED	REV.	DATE	ADDITIONAL INFORMATION
		CHECKED			CHECKED			STATUS OF DRAWING
								APPROVED

RATING = 3000#

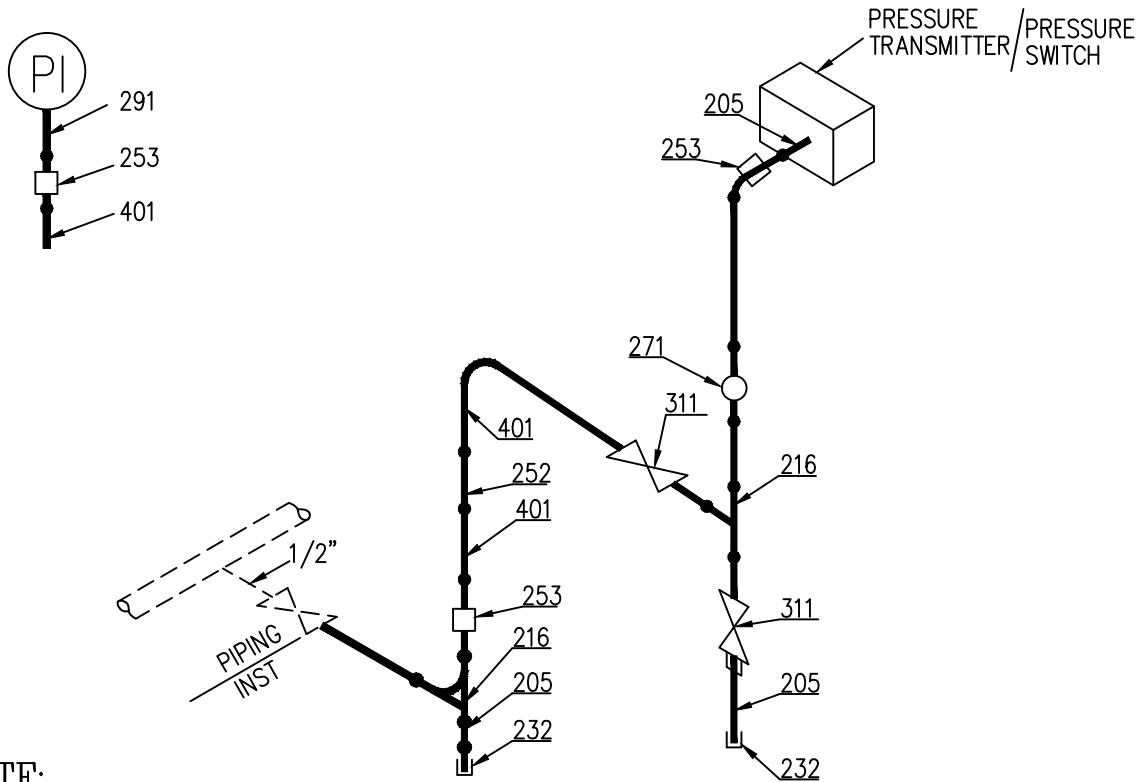



**NOTE:**

PIPE CAN BE TAPPED FOR THREADING WHERE EVER REQUIRED

THE INFORMATION ON THIS DOCUMENT IS THE PROPERTY OF BHARAT HEAVY ELECTRICALS LIMITED. IT MUST NOT BE USED DIRECTLY OR INDIRECTLY IN ANY WAY DETRIMENTAL TO THE INTEREST OF THE COMPANY.  
 REF. DRG. NO. COMPUTER NO. HOOKUP27.DWG  
 SIGN. & DATE  
 INVENTORY NO.

ITEM NO.	DESCRIPTION.	DRAWING NO.	MATL. CODE	GROSS WT
			MATL. SPECN.	QTY.

 BHARAT HEAVY ELECTRICALS LTD. HYDERABAD	DRN.	R.BIJU	-SD-	18.11.93	NO.OF VAR.		
	CKD.	G.R.REDDY	-SD-	18.12.93	-NA-		
	APPD.	G.R.REDDY	-SD-	18.12.93	-NA-		
DEPT.	T.C.E.I		SCALE	WEIGHT(K.G.)	REF.TO ASSY.DRG.	ITEM NO.	NO.OF ITEM
CODE	415		-NA-	-NA-	-NA-	-NA-	-NA-
TITLE					DRAWING NO.	REV.	
PRESSURE INST. CONNECTION (METER ABOVE) STEAM SERVICE					4-312-00-50126	00	
			SHT.NO.	27	NO.OF SHT. 44		

FIRST ANGLE PROJECTION

ALL DIMENSIONS ARE IN mm.

REV.	DATE	ALTERED	REV.	DATE	ALTERED	REV.	DATE	ADDITIONAL INFORMATION
		CHECKED			CHECKED			STATUS OF DRAWING
								APPROVED



THE INFORMATION ON THIS DOCUMENT IS THE PROPERTY OF BHARAT HEAVY ELECTRICALS LIMITED. IT MUST NOT BE USED DIRECTLY OR INDIRECTLY IN ANY WAY DETRIMENTAL TO THE INTEREST OF THE COMPANY.

POS No.	DESCRIPTION	MATERIAL	QTY	MATERIAL CODE
401	PIPE DIA 1/2" SCH 80 ø21.3x3.7	SA 335 GR P22	15M	AA106933086
252	COUPLING ø1/2" SW-F,6000	SA 182 F22	2	AA7242520401
216	T-UNION ø1/2" SW-F	SA 182 F22	2	AA7242510228
205	NIPPLE ø1/2" BW/NPTM	AS	3	HY7242578647
232	CAP ø1/2" NPT	AS	2	HY7242579228
311	GLOBE VALVE ø1/2"SW-M	AS	2	AA7501534586
271	SYPHON 80S BW ø1/2"BW-M	SA 335 GR P11	1	HY7316201630
291	ADAPTOR NPT/BWF/M ø1/2"BW-F	SA 335 GR P22	1	TC9755411038
253	DILO COUPLING 1/2"-3000	SA 182 F22	2	TC9756105046

REF. DRG. NO. COMPUTER NO.  
HOOKUP28.DWG

ITEM NO.	DESCRIPTION.	DRAWING NO.	MATL. CODE	GROSS WT
			MATL. SPECN.	QTY.

SIGN. & DATE  
INVENTORY NO.

 BHARAT HEAVY ELECTRICALS LTD. HYDERABAD	DRN.	R.BIJU	-SD-	18.11.93	NO.OF VAR.				
	CKD.	G.R.REDDY	-SD-	18.12.93	-NA-				
	APPD.	G.R.REDDY	-SD-	18.12.93	-NA-				
DEPT. T.C.E.I	 SCALE -NA-	WEIGHT(K.G.)	-NA-	REF.TO ASSY.DRG.	-NA-	ITEM NO.	-NA-	NO.OF ITEM	-NA-
CODE 415									
TITLE				DRAWING NO.		REV.			
BILL OF MATERIAL FOR SHEET 27				4-312-00-50126		00			
				SHT.NO. 28		NO.OF SHT. 44			

FIRST ANGLE PROJECTION



ALL DIMENSIONS ARE IN mm.

REV.	DATE	ALTERED	REV.	DATE	ALTERED	REV.	DATE	ADDITIONAL INFORMATION
		CHECKED			CHECKED			STATUS OF DRAWING
								APPROVED

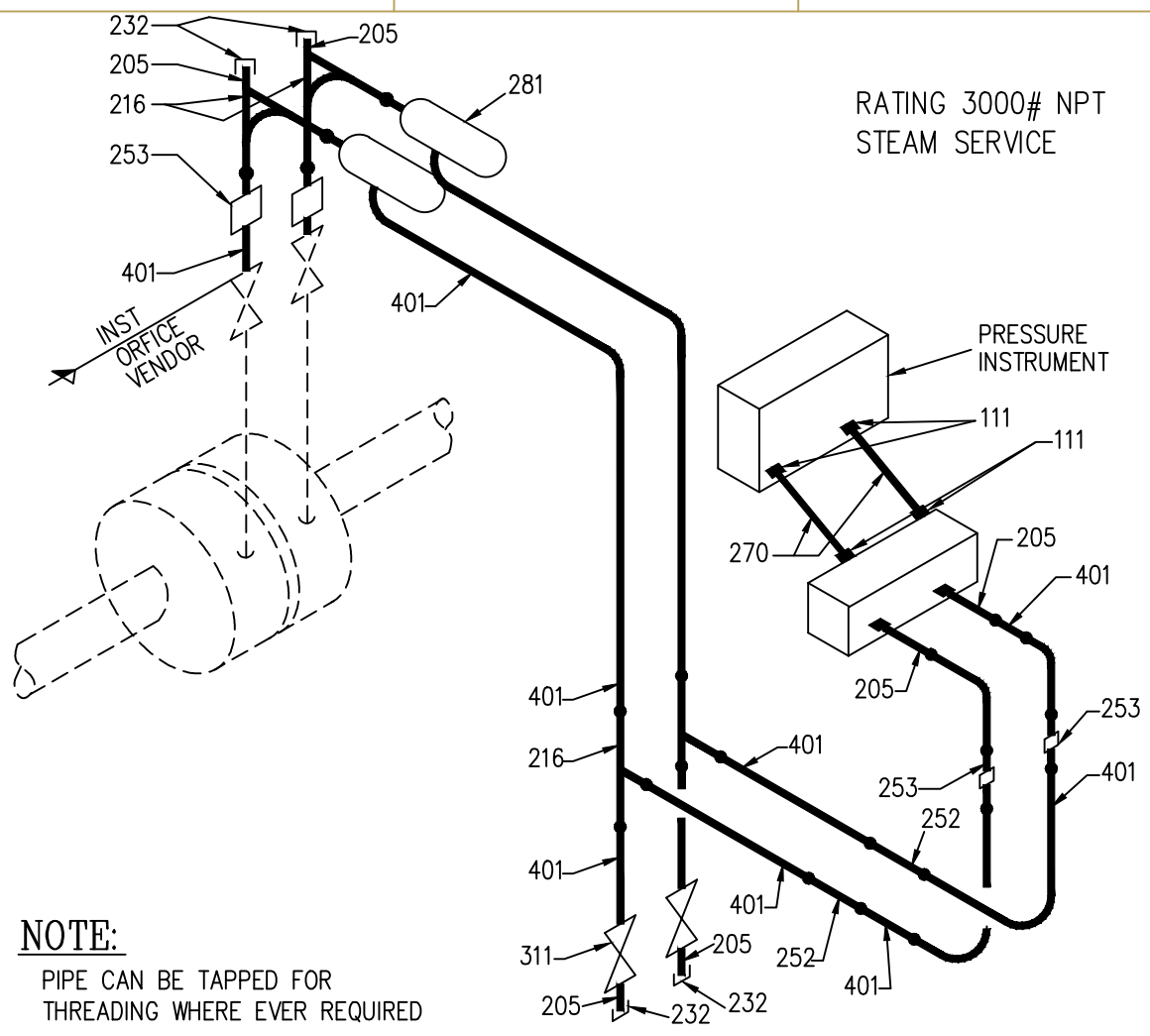
REF. DRG. NO. COMPUTER NO. HOOKUP29.DWG  
 SIGN. & DATE  
 INVENTORY NO.



ITEM NO.	DESCRIPTION.	DRAWING NO.	MATL. CODE	GROSS WT
			MATL. SPECN.	QTY.

 BHARAT HEAVY ELECTRICALS LTD. HYDERABAD	DRN.	R.BIJU	-SD-	18.11.93	NO.OF VAR.	
	CKD.	G.R.REDDY	-SD-	18.12.93	-NA-	
	APPD.	G.R.REDDY	-SD-	18.12.93	-NA-	
DEPT. T.C.E.I		SCALE	WEIGHT(K.G.)	REF.TO ASSY.DRG.	ITEM NO.	NO.OF ITEM
CODE 415		-NA-	-NA-	-NA-	-NA-	-NA-
TITLE				DRAWING NO.	REV.	
FLOW INSTRUMENT-DPT (METER BELOW) STEAM SERVICE				4-312-00-50126	00	
				SHT.NO. 29	NO.OF SHT. 44	

FIRST ANGLE PROJECTION

ALL DIMENSIONS ARE IN mm.

REV.	DATE	ALTERED	REV.	DATE	ALTERED	REV.	DATE	ADDITIONAL INFORMATION
		CHECKED			CHECKED			STATUS OF DRAWING
								APPROVED



THE INFORMATION ON THIS DOCUMENT IS THE PROPERTY OF BHARAT HEAVY ELECTRICALS LIMITED. IT MUST NOT BE USED DIRECTLY OR INDIRECTLY IN ANY WAY DETRIMENTAL TO THE INTEREST OF THE COMPANY.

POS No.	DESCRIPTION	MATERIAL	QTY	MATERIAL CODE
401	PIPE DIA 1/2" SCH 80 ø21.3x3.7	SA335 GR P22	15M	AA1069330086
252	COUPLING ø1/2" SW-F	SA182 F22	4	AA7242520401
216	T-UNION ø1/2" SW-F	SA182 F22	4	AA7242510228
205	NIPPLE ø1/2" BW/NPTM	AS	6	HY7242578647
232	CAP ø1/2" NPT	AS	4	HY7242579228
311	GLOBE VALVE ø1/2"SW-F	AS	2	AA7501534586
301	5 WAY MANIFOLD ø1/2"NPT-F	SS316	1	HY7316561017
281	CONDENSATE POT ø1/2"SW-F	SS316	2	TC9755535047
253	DILO COUPLING ø1/2"BW-M	SA182 F22	4	TC9756105046
270	SS TUBE OD-12.7MM t=2.1MM	SS316	2M	HY1071090054
111	MALE CONNECTOR ø1/2"NPT-M	SS316	4	GT9754229074

REF. DRG. NO. COMPUTER NO.  
HOOKUP30.DWG

ITEM NO.	DESCRIPTION.	DRAWING NO.	MATL. CODE	GROSS WT
			MATL. SPECN.	QTY.

SIGN. & DATE  
INVENTORY NO.

 BHARAT HEAVY ELECTRICALS LTD. HYDERABAD	DRN.	R.BIJU	-SD-	18.11.93	NO.OF VAR.
	CKD.	G.R.REDDY	-SD-	18.12.93	-NA-
	APPD.	G.R.REDDY	-SD-	18.12.93	-NA-
DEPT. T.C.E.I	 SCALE -NA- WEIGHT(K.G.) -NA-	REF.TO ASSY.DRG. -NA-		ITEM NO. -NA-	NO.OF ITEM -NA-
CODE 415					
TITLE		DRAWING NO.			REV.
BILL OF MATERIAL FOR SHEET 29		4-312-00-50126			00
		SHT.NO. 30	NO.OF SHT. 44		

FIRST ANGLE PROJECTION

ALL DIMENSIONS ARE IN mm.



REV.	DATE	ALTERED	REV.	DATE	ALTERED	REV.	DATE	ADDITIONAL INFORMATION
		CHECKED			CHECKED			STATUS OF DRAWING
								APPROVED

REF. DRG. NO. COMPUTER NO. HOOKUP31.DWG  
 SIGN. & DATE  
 INVENTORY NO.  
 THE INFORMATION ON THIS DOCUMENT IS THE PROPERTY OF BHARAT HEAVY ELECTRICALS LIMITED. IT MUST NOT BE USED DIRECTLY OR INDIRECTLY IN ANY WAY DETRIMENTAL TO THE INTEREST OF THE COMPANY.

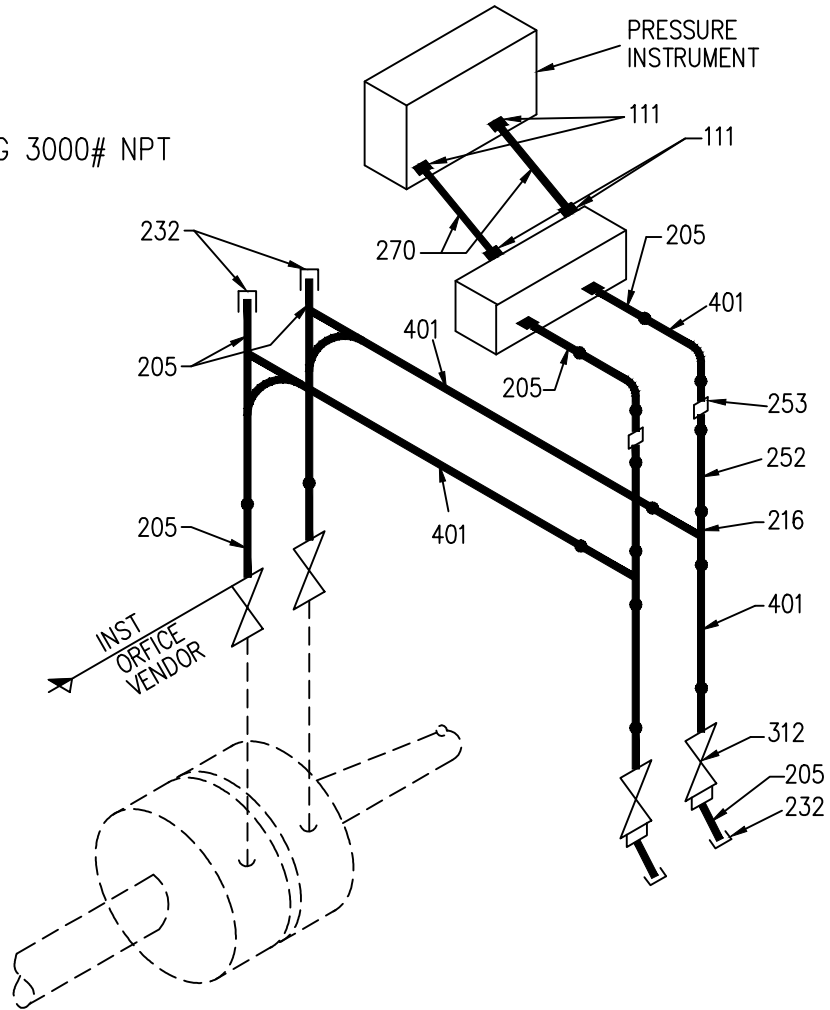
RATING 3000# NPT



ITEM NO.	DESCRIPTION.	DRAWING NO.	MATL. CODE	GROSS WT
			MATL. SPECN.	QTY.

 BHARAT HEAVY ELECTRICALS LTD. HYDERABAD	DRN.	R.BIJU	-SD-	18.11.93	NO.OF VAR. -NA-	
	CKD.	G.R.REDDY	-SD-	18.12.93		
	APPD.	G.R.REDDY	-SD-	18.12.93		
DEPT. T.C.E.I		SCALE	WEIGHT(K.G.)	REF.TO ASSY.DRG.	ITEM NO.	NO.OF ITEM
CODE 415		-NA-	-NA-	-NA-	-NA-	-NA-
TITLE FLOW INSTRUMENT-DPT LIQUID & GAS SERVICE (METER ABOVE)				DRAWING NO. 4-312-00-50126		REV. 00
			SHT.NO. 31	NO.OF SHT. 44		

FIRST ANGLE PROJECTION

ALL DIMENSIONS ARE IN mm.

REV.	DATE	ALTERED	REV.	DATE	ALTERED	REV.	DATE	ADDITIONAL INFORMATION
		CHECKED			CHECKED			STATUS OF DRAWING
								APPROVED



THE INFORMATION ON THIS DOCUMENT IS THE PROPERTY OF BHARAT HEAVY ELECTRICALS LIMITED. IT MUST NOT BE USED DIRECTLY OR INDIRECTLY IN ANY WAY DETRIMENTAL TO THE INTEREST OF THE COMPANY.

POS No.	DESCRIPTION	MATERIAL	QTY	MATERIAL CODE
401	PIPE DIA 1/2" SCH 80 ø21.3x3.7	SA335 Gr P22	15M	AA106933086
252	COUPLING ø1/2" SW-F	SA182 F22	4	AA7242520401
216	T-UNION ø1/2" SW-F	SA182 F22	4	AA7242510228
205	NIPPLE ø1/2" BW/NPTM	AS	6	AA7242578647
232	CAP ø1/2" NPT	AS	4	HY7242579228
311	GLOBE VALVE ø1/2"SW-F	AS	2	AA7501534586
301	5 WAY MANIFOLD ø1/2"NPT-F	SS316	1	HY7316561017
281	CONDENSATE POT ø1/2"SW-F	SS316	2	TC9755535047
253	DILO COUPLING ø1/2"BW-M	SA182F22	4	TC9756105046
270	SS TUBE OD-12.7MM t=2.1MM	SS316	2M	HY1071090054
111	MALE CONNECTOR ø1/2"NPT-M	SS316	4	GT9754229074

REF. DRG. NO. COMPUTER NO.  
HOOKUP32.DWG

SIGN. & DATE  
INVENTORY NO.

ITEM NO.	DESCRIPTION.	DRAWING NO.	MATL. CODE	GROSS WT
			MATL. SPECN.	QTY.

 BHARAT HEAVY ELECTRICALS LTD. HYDERABAD	DRN.	R.BIJU	-SD-	18.11.93	NO.OF VAR.
	CKD.	G.R.REDDY	-SD-	18.12.93	-NA-
	APPD.	G.R.REDDY	-SD-	18.12.93	-NA-
DEPT. T.C.E.I	 SCALE -NA- WEIGHT(K.G.) -NA-	REF.TO ASSY.DRG. -NA-		ITEM NO. -NA-	NO.OF ITEM -NA-
CODE 415		DRAWING NO. 4-312-00-50126		REV. 00	
TITLE BILL OF MATERIAL FOR SHEET 31		SHT.NO. 32	NO.OF SHT. 44		

FIRST ANGLE PROJECTION

ALL DIMENSIONS ARE IN mm.

REV.	DATE	ALTERED	REV.	DATE	ALTERED	REV.	DATE	ADDITIONAL INFORMATION
		CHECKED			CHECKED			STATUS OF DRAWING
								APPROVED

REF. DRG. NO. COMPUTER NO. HOOKUP33.DWG  
 SIGN. & DATE  
 INVENTORY NO.

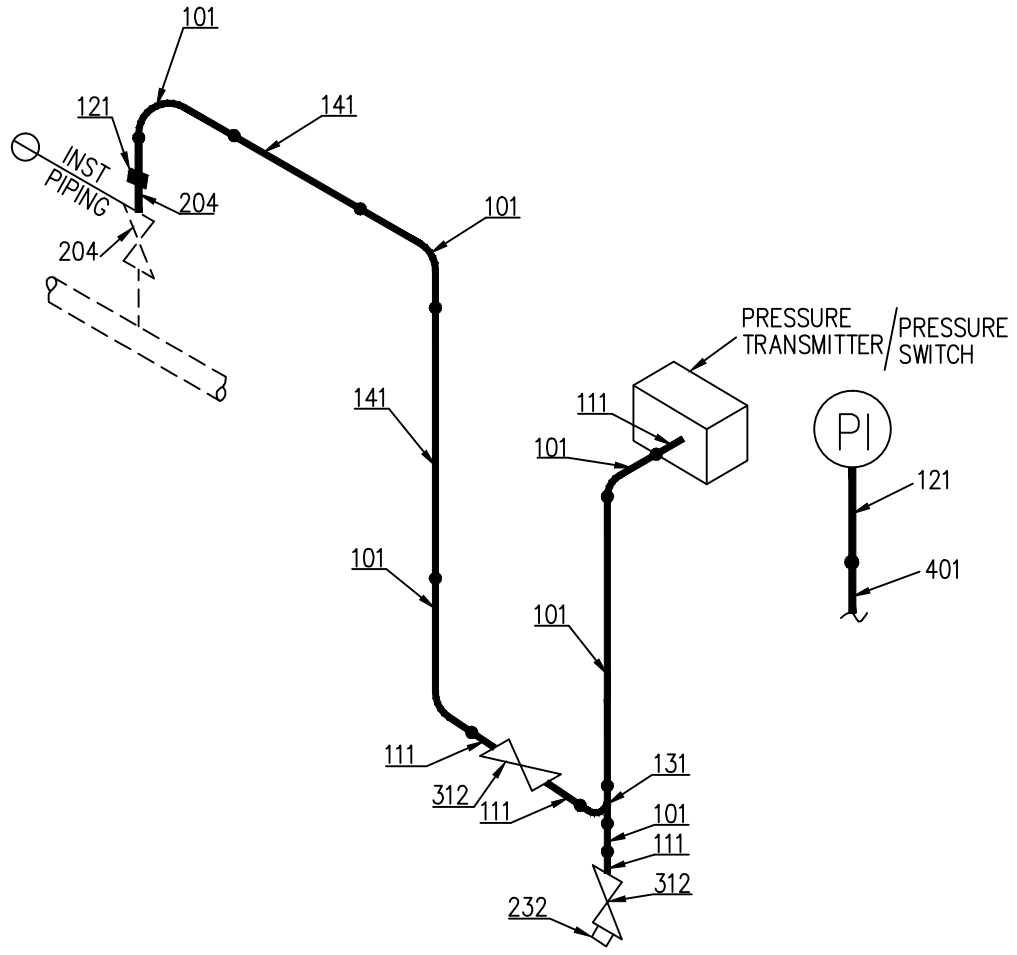

ITEM NO.	DESCRIPTION.	DRAWING NO.	MATL. CODE	GROSS WT
			MATL. SPECN.	QTY.



BHARAT HEAVY ELECTRICALS LTD.  
HYDERABAD

	NAME	SIGN	DATE	NO.OF VAR.
DRN.	R.BIJU	-SD-	18.11.93	
CKD.	G.R.REDDY	-SD-	18.12.93	-NA-
APPD.	G.R.REDDY	-SD-	18.12.93	

DEPT.	T.C.E.I		SCALE	WEIGHT(K.G.)	REF.TO ASSY.DRG.	ITEM NO.	NO.OF ITEM
CODE	415		-NA-	-NA-	-NA-	-NA-	-NA-

TITLE	PRESSURE INST CONNECTION (METER BELOW) GAS/LIQUID/COND. VAPOUR/OIL SERVICE	DRAWING NO.	4-312-00-50126	REV.	00
		SHT.NO.	33	NO.OF SHT.	44

FIRST ANGLE PROJECTION

ALL DIMENSIONS ARE IN mm.

REV.	DATE	ALTERED	REV.	DATE	ALTERED	REV.	DATE	ADDITIONAL INFORMATION
		CHECKED			CHECKED			STATUS OF DRAWING
								APPROVED



THE INFORMATION ON THIS DOCUMENT IS THE PROPERTY OF BHARAT HEAVY ELECTRICALS LIMITED. IT MUST NOT BE USED DIRECTLY OR INDIRECTLY IN ANY WAY DETRIMENTAL TO THE INTEREST OF THE COMPANY.

POS No.	DESCRIPTION	MATERIAL	QTY	MATERIAL CODE
101	STAINLESS STEEL TUBE ø12.7x2.1	SS 304	15M	HY1071090054
111	MALE CONNECTOR ø1/2" NPT-M	SS 316	4	GT9754229074
121	FEMALE CONNECTOR ø1/2" NPT-F	SS 316	2	GT9754229988
131	T-UNION ø12.7 OD	SS 316	1	GT9754229058
141	STRAIGHT UNION ø12.7 OD	SS 316	2	GT9754229015
204	NIPPLE 1/2" NPT/BW	SS 316	1	HY7242578841
232	PLUG ø1/2" NPT-M	SS 316	1	HY7242584280
312	NEEDLE VALVE ø1/2" NPT-F	SS 316	2	TCN731640006

REF. DRG. NO. COMPUTER NO.  
HOOKUP34.DWG

ITEM NO.	DESCRIPTION.	DRAWING NO.	MATL. CODE	GROSS WT
			MATL. SPECN.	QTY.

SIGN. & DATE  
INVENTORY NO.

 BHARAT HEAVY ELECTRICALS LTD. HYDERABAD	DRN.	R.BIJU	-SD-	18.11.93	NO.OF VAR.
	CKD.	G.R.REDDY	-SD-	18.12.93	-NA-
	APPD.	G.R.REDDY	-SD-	18.12.93	-NA-
DEPT. T.C.E.I		SCALE	WEIGHT(K.G.)	REF.TO ASSY.DRG.	ITEM NO.
CODE 415		-NA-	-NA-	-NA-	-NA-
TITLE				DRAWING NO.	REV.
BILL OF MATERIAL FOR SHEET 33				4-312-00-50126	00
				SHT.NO. 34	NO.OF SHT. 44

FIRST ANGLE PROJECTION

ALL DIMENSIONS ARE IN mm.



REV.	DATE	ALTERED	REV.	DATE	ALTERED	REV.	DATE	ADDITIONAL INFORMATION
		CHECKED			CHECKED			STATUS OF DRAWING
								APPROVED

REF. DRG. NO. COMPUTER NO. HOOKUP35.DWG  
 SIGN. & DATE  
 INVENTORY NO.

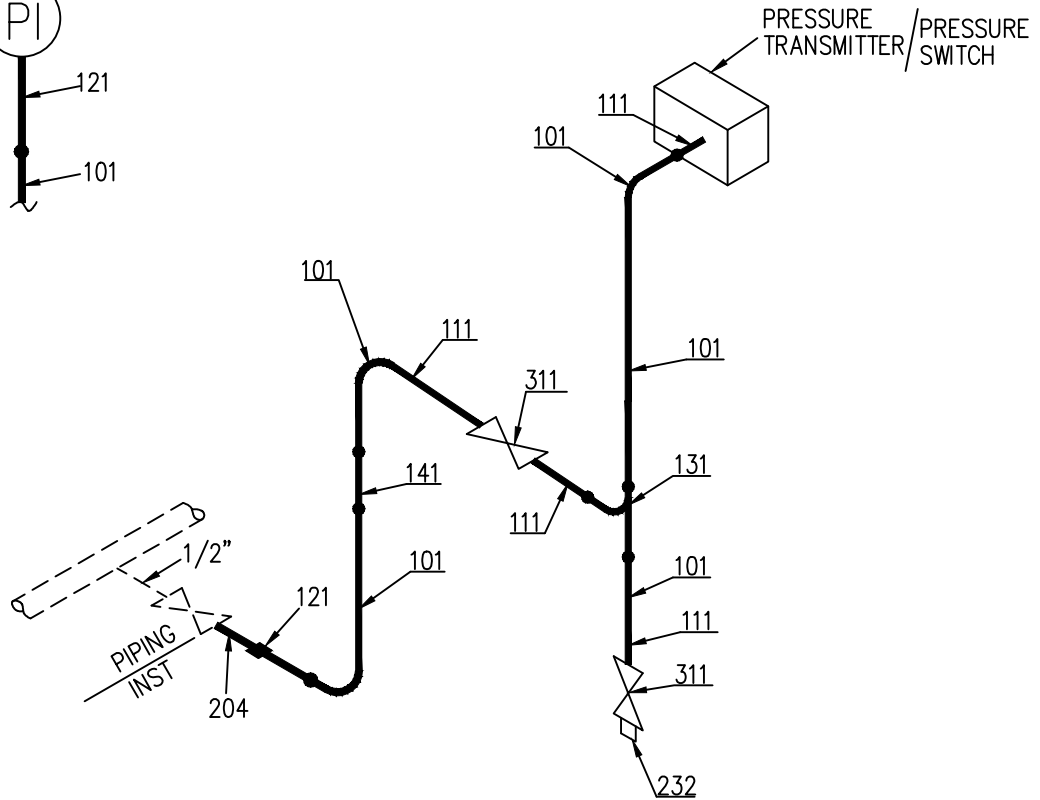
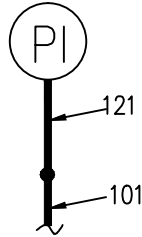
PRESSURE GAUGE



ITEM NO.	DESCRIPTION.	DRAWING NO.	MATL. CODE	GROSS WT
			MATL. SPECN.	QTY.

 BHARAT HEAVY ELECTRICALS LTD. HYDERABAD	DRN.	R.BIJU	-SD-	18.11.93	NO.OF VAR.		
	CKD.	G.R.REDDY	-SD-	18.12.93	-NA-		
	APPD.	G.R.REDDY	-SD-	18.12.93	-NA-		
DEPT.	T.C.E.I		SCALE	WEIGHT(K.G.)	REF.TO ASSY.DRG.	ITEM NO.	NO.OF ITEM
CODE	415		-NA-	-NA-	-NA-	-NA-	-NA-
TITLE			DRAWING NO.		REV.		
PRESSURE INST. CONNECTION (METER ABOVE) GAS/LIQUID/COND./ VAPOUR/OIL SERVICE			4-312-00-50126		00		
			SHT.NO.	NO.OF SHT.			
			35	44			

FIRST ANGLE PROJECTION

ALL DIMENSIONS ARE IN mm.

REV.	DATE	ALTERED	REV.	DATE	ALTERED	REV.	DATE	ADDITIONAL INFORMATION
		CHECKED			CHECKED			STATUS OF DRAWING
								APPROVED



THE INFORMATION ON THIS DOCUMENT IS THE PROPERTY OF BHARAT HEAVY ELECTRICALS LIMITED. IT MUST NOT BE USED DIRECTLY OR INDIRECTLY IN ANY WAY DETRIMENTAL TO THE INTEREST OF THE COMPANY.

POS No.	DESCRIPTION	MATERIAL	QTY	MATERIAL CODE
101	STAINLESS STEEL TUBE ø12.7x2.1	SS 304	15M	HY1071090054
111	MALE CONNECTOR ø1/2" NPT-M	SS 316	4	GT9754229074
121	FEMALE CONNECTOR ø1/2" NPT-F	SS 316	2	GT9754229988
131	T-UNION ø12.7 OD	SS 316	1	GT9754229058
141	STRAIGHT UNION ø12.7 OD	SS 316	2	GT9754229015
204	NIPPLE 1/2" NPT/SW	SS 316	1	HY7242578841
232	PLUG ø1/2" NPT-M	SS 316	1	HY7242584280
311	NEEDLE VALVE ø1/2" NPT-F	SS 316	2	TCN731640006

REF. DRG. NO. COMPUTER NO.  
HOOKUP36.DWG

ITEM NO.	DESCRIPTION.	DRAWING NO.	MATL. CODE	GROSS WT
			MATL. SPECN.	QTY.

SIGN. & DATE  
INVENTORY NO.

 BHARAT HEAVY ELECTRICALS LTD. HYDERABAD	DRN.	R.BIJU	-SD-	18.11.93	NO.OF VAR.
	CKD.	G.R.REDDY	-SD-	18.12.93	-NA-
	APPD.	G.R.REDDY	-SD-	18.12.93	-NA-
DEPT. T.C.E.I		SCALE	WEIGHT(K.G.)	REF.TO ASSY.DRG.	ITEM NO.
CODE 415		-NA-	-NA-	-NA-	-NA-
TITLE				DRAWING NO.	REV.
BILL OF MATERIAL FOR SHEET 35				4-312-00-50126	00
				SHT.NO. 36	NO.OF SHT. 44

FIRST ANGLE PROJECTION

ALL DIMENSIONS ARE IN mm.

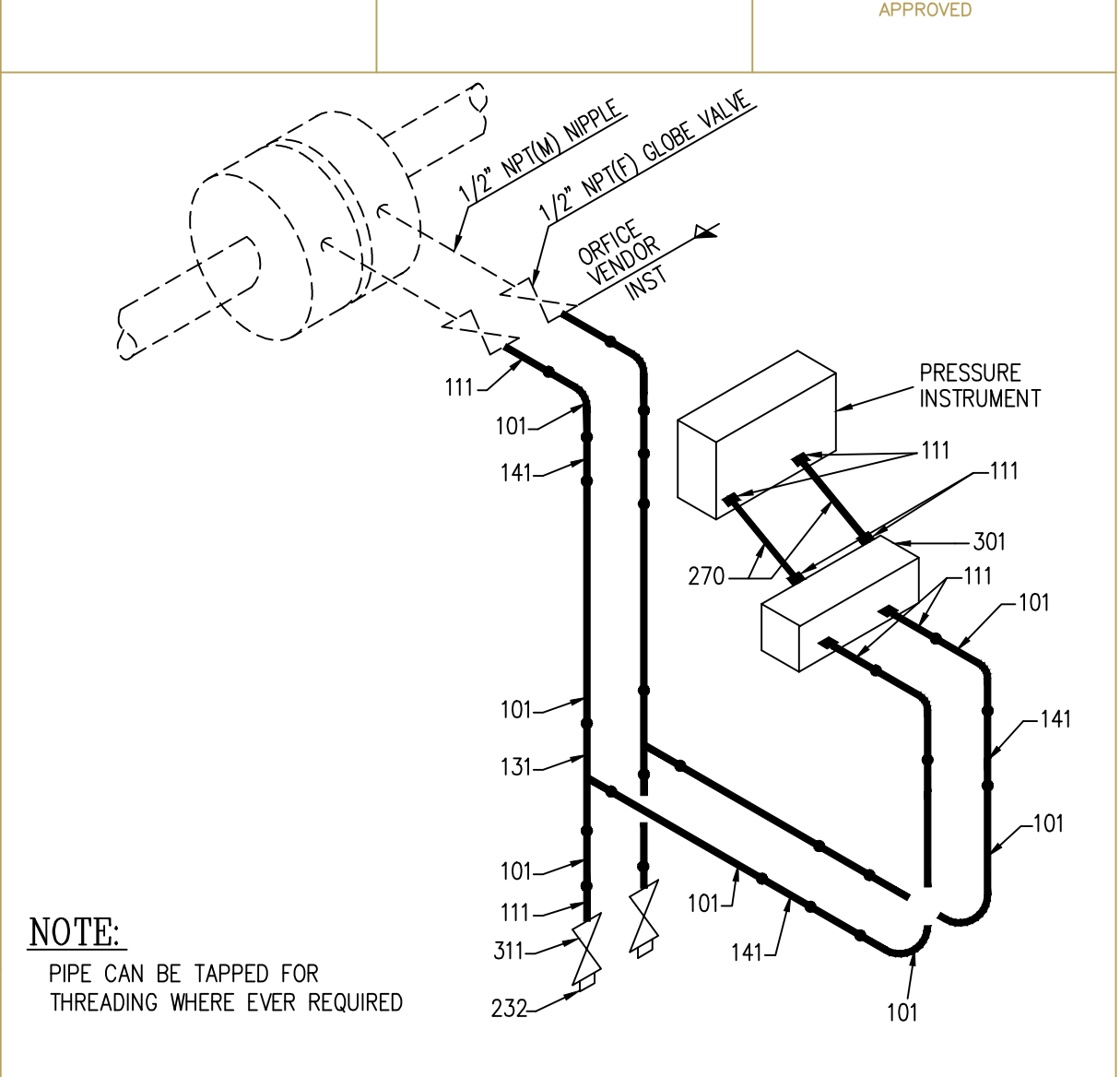

REV.	DATE	ALTERED	REV.	DATE	ALTERED	REV.	DATE	ADDITIONAL INFORMATION
		CHECKED			CHECKED			STATUS OF DRAWING
								APPROVED

REF. DRG. NO. COMPUTER NO. HOOKUP37.DWG  
 SIGN. & DATE  
 INVENTORY NO.



**NOTE:**  
 PIPE CAN BE TAPPED FOR  
 THREADING WHERE EVER REQUIRED

ITEM NO.	DESCRIPTION.	DRAWING NO.	MATL. CODE	GROSS WT
			MATL. SPECN.	QTY.

 BHARAT HEAVY ELECTRICALS LTD. HYDERABAD	DRN.	R.BIJU	-SD-	18.11.93	NO.OF VAR.		
	CKD.	G.R.REDDY	-SD-	18.12.93	-NA-		
	APPD.	G.R.REDDY	-SD-	18.12.93	-NA-		
DEPT.	T.C.E.I		SCALE	WEIGHT(K.G.)	REF.TO ASSY.DRG.	ITEM NO.	NO.OF ITEM
CODE	415		-NA-	-NA-	-NA-	-NA-	-NA-
TITLE			DRAWING NO.		REV.		
FLOW INSTRUMENT-DP TYPE GAS/LIQUID & COND. VAPOUR SERVICE METER BELOW			4-312-00-50126		00		
			SHT.NO.	NO.OF SHT.			
			37	44			

FIRST ANGLE PROJECTION

ALL DIMENSIONS ARE IN mm.

REV.	DATE	ALTERED	REV.	DATE	ALTERED	REV.	DATE	ADDITIONAL INFORMATION
		CHECKED			CHECKED			STATUS OF DRAWING
								APPROVED



THE INFORMATION ON THIS DOCUMENT IS THE PROPERTY OF BHARAT HEAVY ELECTRICALS LIMITED. IT MUST NOT BE USED DIRECTLY OR INDIRECTLY IN ANY WAY DETRIMENTAL TO THE INTEREST OF THE COMPANY.

POS No.	DESCRIPTION	MATERIAL	QTY	MATERIAL CODE
101	STAINLESS STEEL TUBE ø12.7x2.1	SS 304	15M	HY1071090054
111	MALE CONNECTOR ø1/2" NPT-M	SS 316	10	GT9754229074
301	5-WAY MANIFOLD ø1/2" NPT-F	SS 316	1	HY7316561017
131	T-UNION ø12.7 OD	SS 316	2	GT9754229058
141	STRAIGHT UNION ø12.7 OD	SS 316	4	GT9754229015
232	PLUG ø1/2" NPT-M	SS 316	2	HY7242584280
311	NEEDLE VALVE ø1/2" NPT-F	SS 316	2	TCN731640006

REF. DRG. NO. COMPUTER NO.  
HOOKUP38.DWG

ITEM NO.	DESCRIPTION.	DRAWING NO.	MATL. CODE	GROSS WT
			MATL. SPECN.	QTY.

SIGN. & DATE  
INVENTORY NO.

 BHARAT HEAVY ELECTRICALS LTD. HYDERABAD	DRN.	R.BIJU	-SD-	18.11.93	NO.OF VAR.
	CKD.	G.R.REDDY	-SD-	18.12.93	-NA-
	APPD.	G.R.REDDY	-SD-	18.12.93	-NA-
DEPT. T.C.E.I		SCALE	WEIGHT(K.G.)	REF.TO ASSY.DRG.	ITEM NO.
CODE 415		-NA-	-NA-	-NA-	-NA-
TITLE				DRAWING NO.	REV.
BILL OF MATERIAL FOR SHEET 37				4-312-00-50126	00
			SHT.NO. 38	NO.OF SHT. 44	

FIRST ANGLE PROJECTION

ALL DIMENSIONS ARE IN mm.



REV.	DATE	ALTERED	REV.	DATE	ALTERED	REV.	DATE	ADDITIONAL INFORMATION
		CHECKED			CHECKED			STATUS OF DRAWING

APPROVED

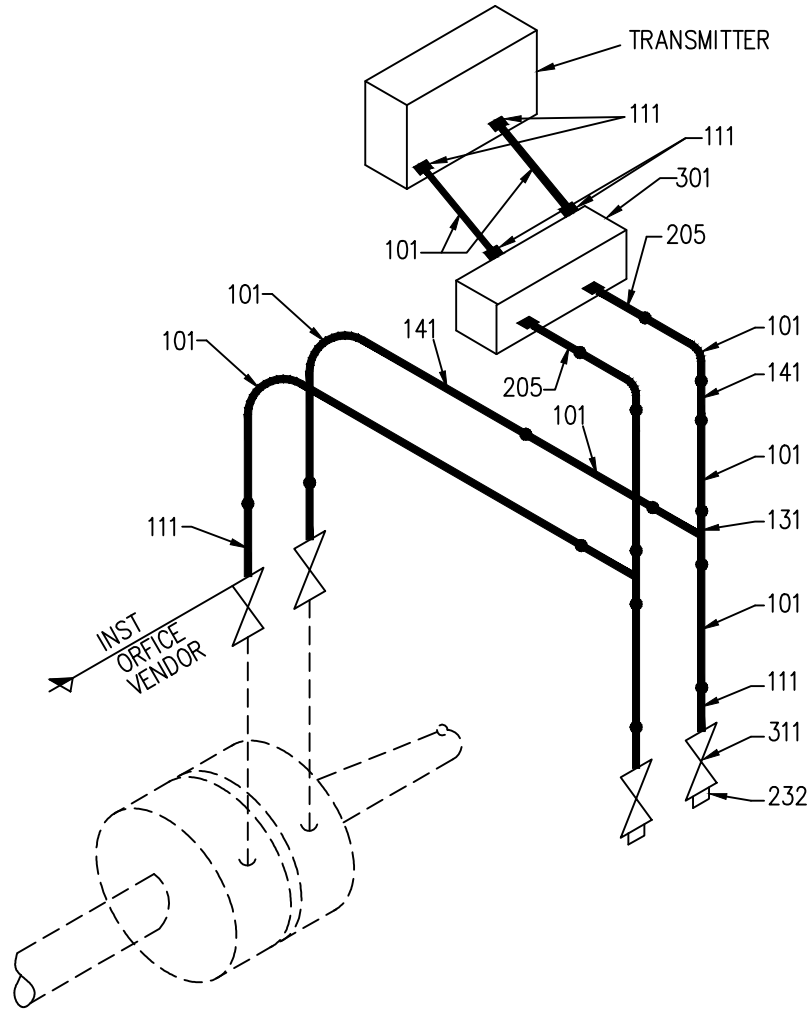
REF. DRG. NO. COMPUTER NO. HOOKUP39.DWG  
 SIGN. & DATE  
 INVENTORY NO.



ITEM NO.	DESCRIPTION.	DRAWING NO.	MATL. CODE	GROSS WT
			MATL. SPECN.	QTY.

 BHARAT HEAVY ELECTRICALS LTD. HYDERABAD	DRN.	R.BIJU	-SD-	18.11.93	NO.OF VAR.	
	CKD.	G.R.REDDY	-SD-	18.12.93	-NA-	
	APPD.	G.R.REDDY	-SD-	18.12.93	-NA-	
DEPT. T.C.E.I		SCALE	WEIGHT(K.G.)	REF.TO ASSY.DRG.	ITEM NO.	NO.OF ITEM
CODE 415		-NA-	-NA-	-NA-	-NA-	-NA-
TITLE FLOW INSTRUMENT-DP TYPE GAS/LIQUID & COND. VAPOUR SERVICE METER ABOVE				DRAWING NO. 4-312-00-50126		REV. 00
				SHT.NO. 39	NO.OF SHT. 44	

FIRST ANGLE PROJECTION

ALL DIMENSIONS ARE IN mm.

REV.	DATE	ALTERED	REV.	DATE	ALTERED	REV.	DATE	ADDITIONAL INFORMATION
		CHECKED			CHECKED			STATUS OF DRAWING
								APPROVED



THE INFORMATION ON THIS DOCUMENT IS THE PROPERTY OF BHARAT HEAVY ELECTRICALS LIMITED. IT MUST NOT BE USED DIRECTLY OR INDIRECTLY IN ANY WAY DETRIMENTAL TO THE INTEREST OF THE COMPANY.

POS No.	DESCRIPTION	MATERIAL	QTY	MATERIAL CODE
101	STAINLESS STEEL TUBE ø12.7x2.1	SS 304	15M	HY1071090054
111	MALE CONNECTOR ø1/2" NPT-M	SS 316	6	GT9754229074
301	5-WAY MANIFOLD ø1/2" NPT-F	SS 316	1	HY7316561017
131	T-UNION ø12.7 OD	SS 316	2	GT9754229058
141	STRAIGHT UNION ø12.7 OD	SS 316	4	GT9754229015
232	PLUG ø1/2" NPT-M	SS 316	2	HY7242584280
311	NEEDLE VALVE ø1/2" NPT-F	SS 316	2	GT9757125024

REF. DRG. NO. COMPUTER NO.  
HOOKUP40.DWG

ITEM NO.	DESCRIPTION.	DRAWING NO.	MATL. CODE	GROSS WT
			MATL. SPECN.	QTY.

SIGN. & DATE  
INVENTORY NO.

 BHARAT HEAVY ELECTRICALS LTD. HYDERABAD	DRN.	R.BIJU	-SD-	18.11.93	NO.OF VAR.	
	CKD.	G.R.REDDY	-SD-	18.12.93	-NA-	
	APPD.	G.R.REDDY	-SD-	18.12.93	-NA-	
DEPT. T.C.E.I	 SCALE -NA-	WEIGHT(K.G.)	-NA-	REF.TO ASSY.DRG.	ITEM NO.	NO.OF ITEM
CODE 415				-NA-	-NA-	-NA-
TITLE				DRAWING NO.		REV.
BILL OF MATERIAL FOR SHEET 39				4-312-00-50126		00
SHT.NO. 40			NO.OF SHT. 44			

FIRST ANGLE PROJECTION

ALL DIMENSIONS ARE IN mm.

REV.	DATE	ALTERED	REV.	DATE	ALTERED	REV.	DATE	ADDITIONAL INFORMATION
		CHECKED			CHECKED			STATUS OF DRAWING
								APPROVED

THIS LOOP IS SUITABLE FOR TEMPERATURE  $\leq 415^{\circ}\text{C}$

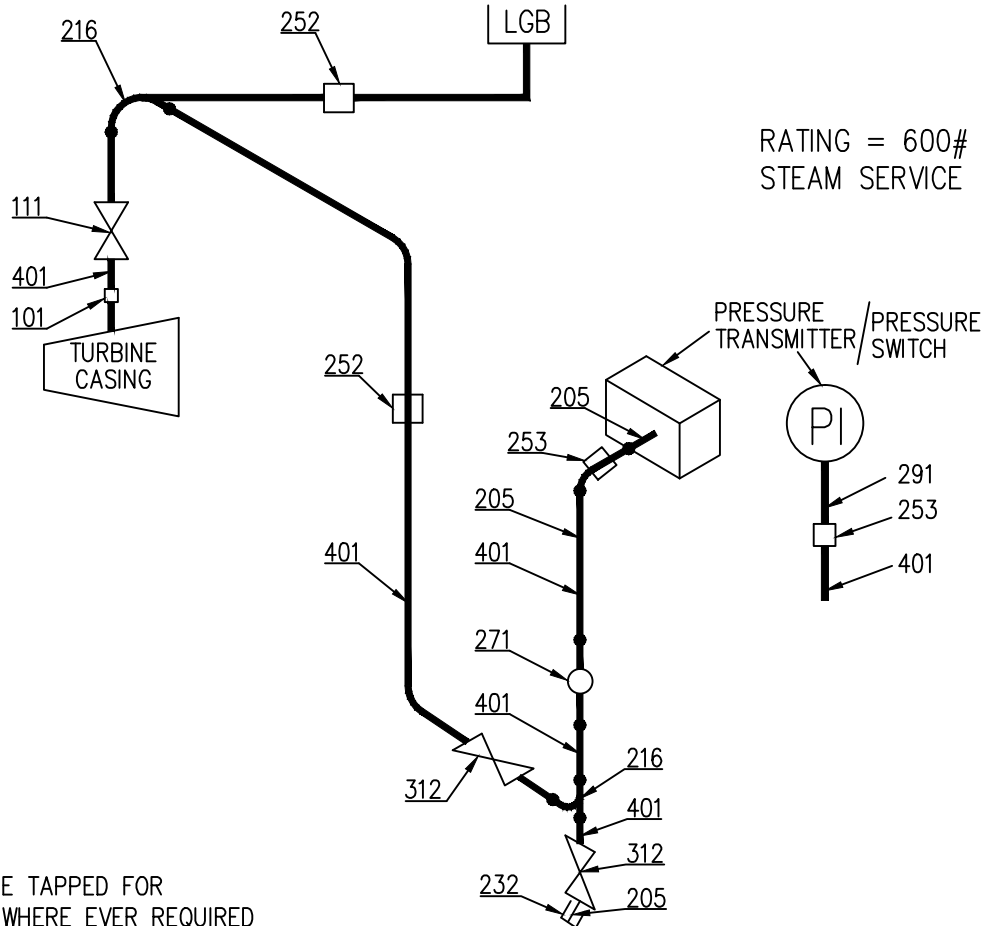



**NOTE:**

PIPE CAN BE TAPPED FOR THREADING WHERE EVER REQUIRED

THE INFORMATION ON THIS DOCUMENT IS THE PROPERTY OF BHARAT HEAVY ELECTRICALS LIMITED. IT MUST NOT BE USED DIRECTLY OR INDIRECTLY IN ANY WAY DETRIMENTAL TO THE INTEREST OF THE COMPANY.  
 REF. DRG. NO. COMPUTER NO. HOOKUP41.DWG  
 SIGN. & DATE  
 INVENTORY NO.

ITEM NO.	DESCRIPTION.	DRAWING NO.	MATL. CODE	GROSS WT
			MATL. SPECN.	QTY.

 BHARAT HEAVY ELECTRICALS LTD. HYDERABAD	DRN.	R.BIJU	-SD-	18.11.93	NO.OF VAR.		
	CKD.	G.R.REDDY	-SD-	18.12.93	-NA-		
	APPD.	G.R.REDDY	-SD-	18.12.93	-NA-		
DEPT.	T.C.E.I		SCALE	WEIGHT(K.G.)	REF.TO ASSY.DRG.	ITEM NO.	NO.OF ITEM
CODE	415		-NA-	-NA-	-NA-	-NA-	-NA-
TITLE			DRAWING NO.		REV.		
PRESSURE GAUGE CONNECTION ANSI RATINGS-1500 (FOR WHEEL CHAMBER MEASUREMENT)			4-312-00-50126		00		
SHT.NO.		41	NO.OF SHT.		44		

FIRST ANGLE PROJECTION

ALL DIMENSIONS ARE IN mm.

REV.	DATE	ALTERED	REV.	DATE	ALTERED	REV.	DATE	ADDITIONAL INFORMATION
		CHECKED			CHECKED			STATUS OF DRAWING
								APPROVED



THE INFORMATION ON THIS DOCUMENT IS THE PROPERTY OF BHARAT HEAVY ELECTRICALS LIMITED. IT MUST NOT BE USED DIRECTLY OR INDIRECTLY IN ANY WAY DETRIMENTAL TO THE INTEREST OF THE COMPANY.

POS No.	DESCRIPTION	MATERIAL	QTY	MATERIAL CODE
111	GATE VALVE 1/2"SW 2500#	A105/II	1	AA7521468589
101	COUPLING 13.5x1.8SW/ 21.3x3.73 SW	C.S	1	HY106266180
401	PIPE DIA 1/2"SW $\phi$ 21.3x3.7	A106	30M	AA1049355083
252	COUPLING $\phi$ 1/2" SW-F	A105	3	AA7242520045
216	T-UNION $\phi$ 1/2" SW-F	A105	2	AA7242510040
205	NIPPLE $\phi$ 1/2" BW/NPT-M	A105	2	HY7242578043
232	CAP $\phi$ 1/2" NPT	A105	1	HY7242579040
312	GLOBE VALVE $\phi$ 1/2" SW-M	A105	2	AA7501501585
271	SYPHON $\phi$ 1/2" BW-M	A105	1	HY7316201622
291	ADAPTOR $\phi$ 1/2" NPT-F/1/2"BW	A105	1	TC9755411020
253	DILO COUPLING 1/2"	A105	2	TC9756105038

REF. DRG. NO. COMPUTER NO.  
HOOKUP42.DWG

SIGN. & DATE  
INVENTORY NO.

ITEM NO.	DESCRIPTION.	DRAWING NO.	MATL. CODE	GROSS WT
			MATL. SPECN.	QTY.

 BHARAT HEAVY ELECTRICALS LTD. HYDERABAD	DRN.	R.BIJU	-SD-	18.11.93	NO.OF VAR.
	CKD.	G.R.REDDY	-SD-	18.12.93	-NA-
	APPD.	G.R.REDDY	-SD-	18.12.93	-NA-
DEPT. T.C.E.I	 SCALE WEIGHT(K.G.)	REF.TO ASSY.DRG.	ITEM NO.	NO.OF ITEM	
CODE 415		-NA-	-NA-	-NA-	
TITLE		DRAWING NO.		REV.	
BILL OF MATERIAL FOR SHEET 41		4-312-00-50126		00	
		SHT.NO. 42	NO.OF SHT. 44		

FIRST ANGLE PROJECTION

ALL DIMENSIONS ARE IN mm.

REV.	DATE	ALTERED	REV.	DATE	ALTERED	REV.	DATE	ADDITIONAL INFORMATION
		CHECKED			CHECKED			STATUS OF DRAWING
								APPROVED

THIS LOOP IS SUITABLE FOR TEMPERATURE BETWEEN 415°C AND 550°C

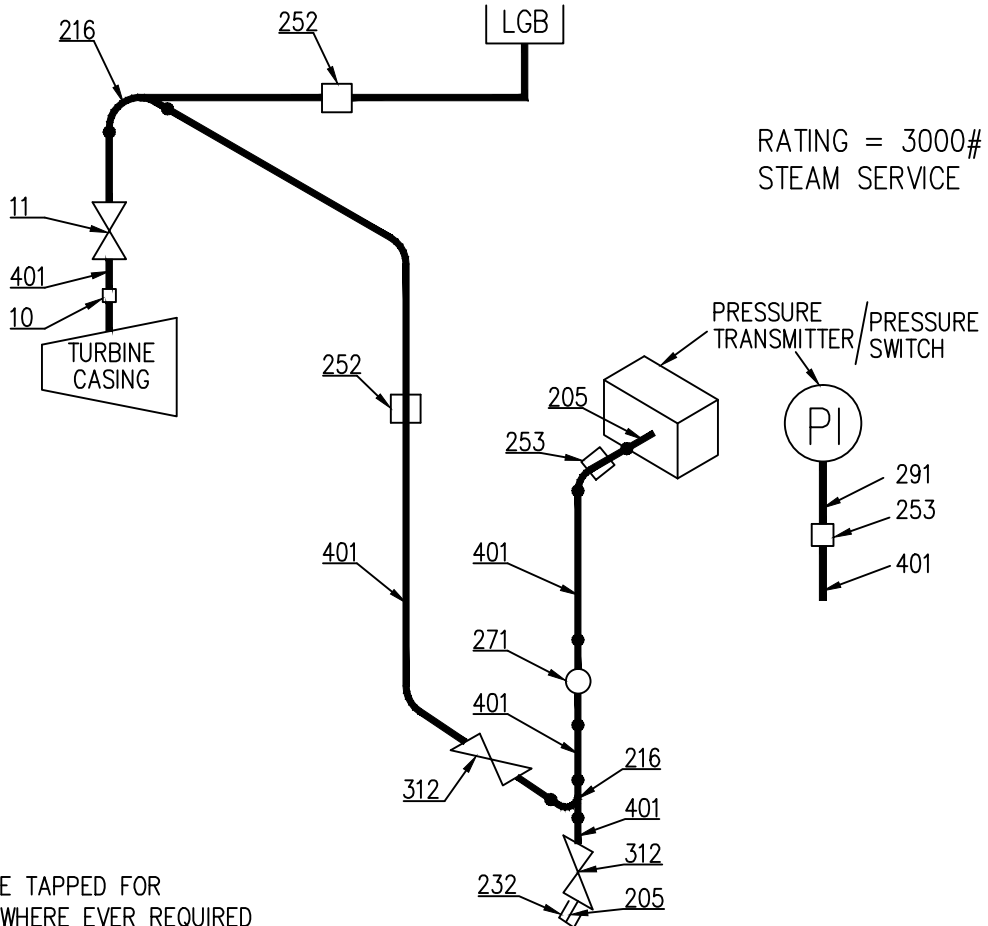



**NOTE:**

PIPE CAN BE TAPPED FOR THREADING WHERE EVER REQUIRED

THE INFORMATION ON THIS DOCUMENT IS THE PROPERTY OF BHARAT HEAVY ELECTRICALS LIMITED. IT MUST NOT BE USED DIRECTLY OR INDIRECTLY IN ANY WAY DETRIMENTAL TO THE INTEREST OF THE COMPANY.  
 REF. DRG. NO. COMPUTER NO. HOOKUP43.DWG  
 SIGN. & DATE  
 INVENTORY NO.

ITEM NO.	DESCRIPTION.	DRAWING NO.	MATL. CODE	GROSS WT
			MATL. SPECN.	QTY.

 BHARAT HEAVY ELECTRICALS LTD. HYDERABAD	DRN.	R.BIJU	-SD-	18.11.93	NO.OF VAR.	
	CKD.	G.R.REDDY	-SD-	18.12.93	-NA-	
	APPD.	G.R.REDDY	-SD-	18.12.93	-NA-	
DEPT. T.C.E.I		SCALE	WEIGHT(K.G.)	REF.TO ASSY.DRG.	ITEM NO.	NO.OF ITEM
CODE 415		-NA-	-NA-	-NA-	-NA-	-NA-
TITLE PRESSURE GAUGE CONNECTION ANSI RATINGS-2500 (FOR WHEEL CHAMBER MEASUREMENT)				DRAWING NO. 4-312-00-50126		REV. 00
			SHT.NO. 43	NO.OF SHT. 44		

FIRST ANGLE PROJECTION

ALL DIMENSIONS ARE IN mm.

REV.	DATE	ALTERED	REV.	DATE	ALTERED	REV.	DATE	ADDITIONAL INFORMATION
		CHECKED			CHECKED			STATUS OF DRAWING
								APPROVED



THE INFORMATION ON THIS DOCUMENT IS THE PROPERTY OF BHARAT HEAVY ELECTRICALS LIMITED. IT MUST NOT BE USED DIRECTLY OR INDIRECTLY IN ANY WAY DETRIMENTAL TO THE INTEREST OF THE COMPANY.

POS No.	DESCRIPTION	MATERIAL	QTY	MATERIAL CODE
11	GATE VALVE 1/2"SW 2500#	A.S	1	AA7501534586
10	COUPLING 13.5x1.8SW/ 21.3x3.73 SW	A.S	1	HY1060266180
401	PIPE DIA 1/2"SW $\phi$ 21.3x3.7	SA335GrP22	30M	AA1069330088
252	COUPLING $\phi$ 1/2" SW-F	SA335GrP22	3	AA7242520401
216	T-UNION $\phi$ 1/2" SW-F	A.S	2	AA7242510228
205	NIPPLE $\phi$ 1/2" BW/NPT-M	A.S	2	HY7242578647
232	CAP $\phi$ 1/2" NPT	A.S	1	HY7242579228
312	GLOBE VALVE $\phi$ 1/2" SW-M	A.S	2	AA7501534586
271	SYPHON $\phi$ 1/2" BW-M	A.S	1	HY7316201630
291	ADAPTOR $\phi$ 1/2" NPT-F/1/2"BW	A.S	1	TC9755411038
253	DILO COUPLING 1/2"	A.S	2	TC9756105046

REF. DRG. NO. COMPUTER NO.  
HOOKUP44.DWG

SIGN. & DATE  
INVENTORY NO.

ITEM NO.	DESCRIPTION.	DRAWING NO.	MATL. CODE	GROSS WT
			MATL. SPECN.	QTY.

 BHARAT HEAVY ELECTRICALS LTD. HYDERABAD	DRN.	R.BIJU	-SD-	18.11.93	NO.OF VAR.
	CKD.	G.R.REDDY	-SD-	18.12.93	-NA-
	APPD.	G.R.REDDY	-SD-	18.12.93	-NA-
DEPT. T.C.E.I		SCALE	WEIGHT(K.G.)	REF.TO ASSY.DRG.	ITEM NO.
CODE 415		-NA-	-NA-	-NA-	-NA-
TITLE				DRAWING NO.	REV.
BILL OF MATERIAL FOR SHEET 43				4-312-00-50126	00
			SHT.NO. 44	NO.OF SHT. 44	

FIRST ANGLE PROJECTION

ALL DIMENSIONS ARE IN mm.

REV.	DATE	ALTERED	ROBINS	REV.	DATE	ALTERED	ROBINS	
		CHECKED	ROBINS		01	21.05.12	CHECKED	ROBINS
		APPROVED	PRAKASH				APPROVED	PRAKASH
REVISED INLINE WITH LMIL / AVANT GARDE			REVISED INLINE WITH LMIL / AVANT GARDE					
COMMENTS VIDE MAIL DTD.31.05.12.			COMMENTS VIDE MAIL DTD.26.03.12.					

THE INFORMATION ON THIS DOCUMENT IS THE PROPERTY OF BHARAT HEAVY ELECTRICALS LIMITED. IT MUST NOT BE USED DIRECTLY OR INDIRECTLY IN ANY WAY DETRIMENTAL TO THE INTEREST OF THE COMPANY.

# INSTRUMENT INSTALLATION DRAWINGS

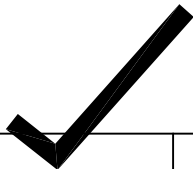

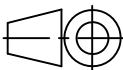
CATEGORY OF DWG.	APPROVAL	INFORMATION	RECORD	REFERENCE			
	CUSTOMER: LOKMANGAL AGRO/MAULI INDUSTRIES LTD.						
PROJECT 1X30MW LOKMANGAL AGRO/MAULI INDS. LTD.							
 BHARAT HEAVY ELECTRICALS LTD. HYDERABAD	DRN.	ROBINS	SIGN.	DATE	NO.OF VAR.		
	CHD.	ROBINS	-----	09.03.12		00	
	APPD.	PRAKASH	-----	09.03.12			
DEPT. PED	UNTOL. DIMS. GR. Ø/M/ƒ		SCALE 1:1	WEIGHT (KG) NA	REF. TO ASSY. DRG. NA	ITEM NO.	NO.OF ITEMS
CODE 450							
TITLE <u>INSTRUMENT INSTALLATION</u> <u>DRAWINGS</u>				CARD CODE	DRAWING NO. 4-381-21-03032		REV. 02
				SHT. No 1	NO. OF SHT. 13		



## GENERAL NOTES

1. TIG WELDING SHALL BE CARRIED OUT AT SITE FOR ALL SMALL PIPES (LESS THAN OR EQUAL TO 2") WITHOUT ANY EXCEPTION (APPLICABLE FOR ALL WELDING JOINTS IN EACH HOOK UP SCHEMES).
2. INSTRUMENT ORIENTATION AT SITE IS SELECTED WITH SUITABLE SPEACE FOR METER READING ACCESSIBILITY AND MAINTENANCE PURPOSE.
3. THE ORIENTATION OF TAPING FROM PROCESS PIPE (VERTICLE/HORIZONTAL) SELECTED IN SUCH WAY THAT PRESSURE/TEMPERATURE GAUGES ARE ACCESSIBLE FOR MAINTENANCE.
4. FOR ALL LINE MOUNTED FLANGED INSTRUMENTS OR WHEREVER FIRST ISOLATION VALVE IS FLANGED – GASKET, STUD BOLTS & NUTS ETC. ARE PROVIDED ALONG WITH PIPING MATERIAL.
5. CONTROL VALVES APPLICABLE FOR ALL SERVICES ARE WITH FLANGED END CONNECTIONS ONLY FLANGE RATING AND MOC SUPPLIED AS PER BHEL PRACTICE.
6. AIR DISTRIBUTION HEADER ASSEMBLED DEPENDING ON LOCATION & NUMBER OF TAKE OFF POINTS IN THE SITE NEAR THE CONSUMPTION AREA WHICH IS AS PER SITE CONVENIENCE. FURTHER DISTRIBUTION FROM HEADER TO CONTROL VLAVE CARRIED OUT BY 6MM OD x 1MM THK PNEUMATIC SS TUBE.
7. INSTALLATION OF JB/ INST MAINTAINED AT A HEIGHT OF UPTO 1.5M FROM GROUND LEVEL OR FINISHED FLOOR LEVEL. SAME CAN BE FINALISED AT SITE.
8. ROOT VALVES FOR ALL THE INSTRUMENTS ARE SUPPLIED ALONG WITH PIPING MATERIAL. NO OF ROOT VALVES (SINGLE / DOUBLE) FOR LOW/HIGH PRESSURE SERVICES ARE AS PER P & ID'S.
9. IMPULSE LINE ROUTING SHOWN IN THIS DRAWING ARE INDICATIVE. ACTUAL ROUTING SHALL BE DECIDED AT SITE & UNNECESSARY BENDS IN IMPULSE LINE SHALL BE AVOIDED AS FAR AS POSSIBLE.
10. ALL IMPULSE LINES ARE FABRICATED USING PIPES (CS/SS) ASPER MATERIAL OF CONSTRUCTION MENTIONED IN PIPING SPECIFICATION AND END/FINAL CONNECTION TO INSTRUMENT WILL BE USING 1/2" ODx0.065" THK ASTM A269 TP TP 316 (FOR ALL EXCEPT STEAM SERVICES) AND A269 TP 321 IN CASE OF GAS SERVICES.
11. INSTRUMENTS LIKE TSV, PSV, TW, TE, FLOW METERS, PRDS, AND DS ETC., DOESN'T HAVE ANY INSTRUMENT HOOK UP SCHEME BECAUSE THEY ARE DIRECTLY FITTED ON PROCESS LINE.
12. THIS DOCUMENT IS FOR PE&SD(C&I)–HYD LOOSE SUPPLIED INSTRUMENT ONLY. FOR MECHANICAL SKID ITEMS, INSTRUMENT WITH HOOKUP WILL BE SUPPLIED AS PACKAGE.

 HYDERABAD	STANDARD	TITLE:	DRG.NO.: 4-381-21-03032	
		GENERAL NOTES	SHEET NO: 3 OF 13	REV. 02

SCHEME 1

SW FITTINGS  
RATING 3000#

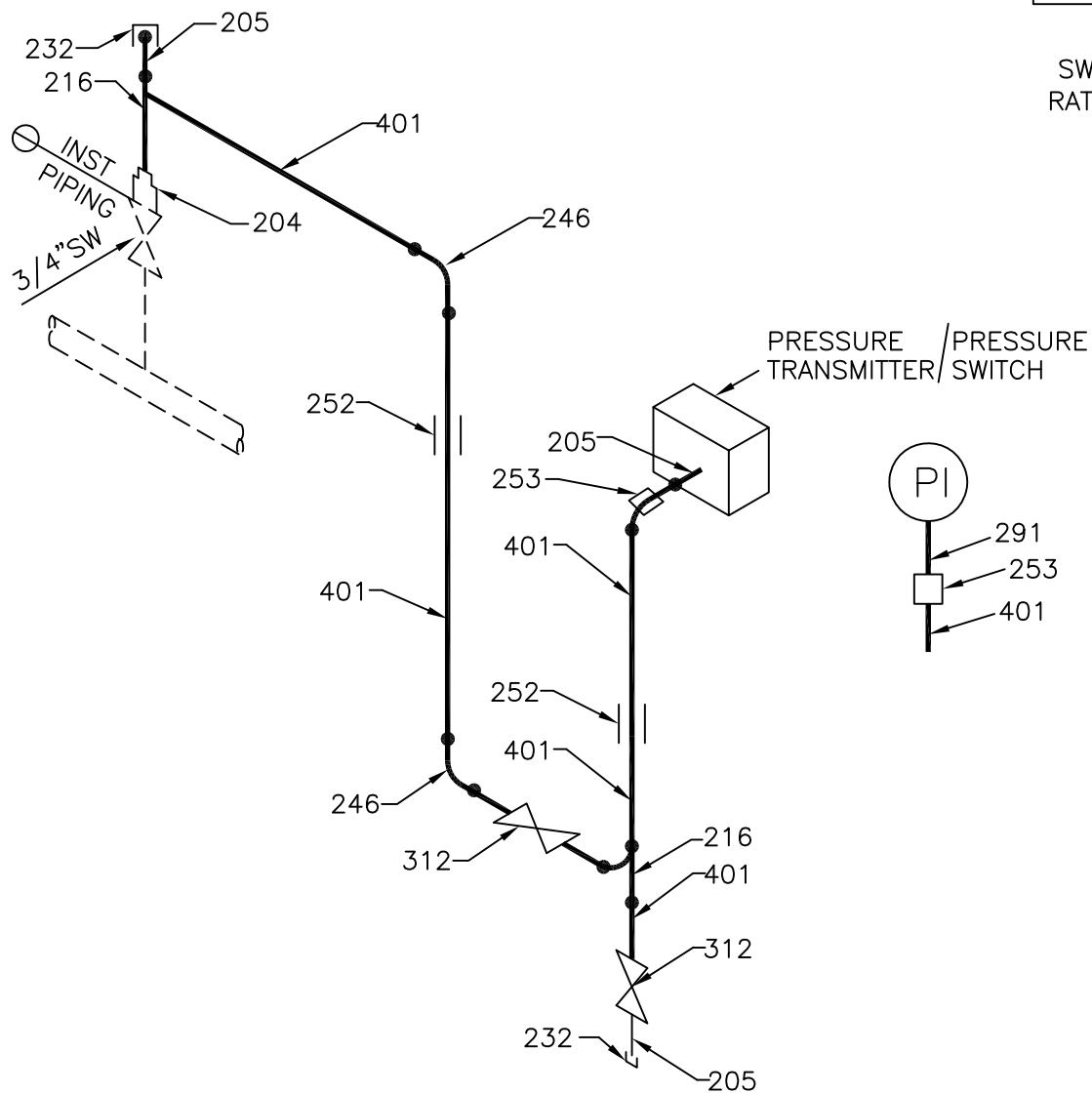

POS NO.	DESCRIPTION	MATERIAL CODE	SITE IDENTIFICATION
401	PIPE DIA 1/2" SCH 80 $\phi$ 21.3x2.8 TP 321	HY1071055623	39626002
246	ELBOW $\phi$ 1/2" SW-F	AA7242501229	39626002
252	COUPLING $\phi$ 1/2" SW-F	AA7242520223	39626002
216	T-UNION $\phi$ 1/2" SW-F	AA7242510228	39626002
205	NIPPLE $\phi$ 1/2" BW/NPTM	HY7242578841	39626002
204	REDUCER NIPPLE $\phi$ 3/4" BWx1/2" BW	HY7242532442	39626002
232	CAP $\phi$ 1/2" NPT-F	HY7242579228	39626002
312	GLOBE VALVE $\phi$ 1/2" SW-M	AA7501478589	39626002
291	ADAPTOR 1/2BW 1/2" NPT(F)	GT9757136018	39626002
253	DILO COUPLING $\phi$ 1/2" SW	TC9756105046	39626002



STANDARD

TITLE:  
PRESSURE GAUGE, PRESSURE  
TRANSMITTERS, PRESSURE SWITCH  
FOR AIR & WATER APPLICATIONS  
WITH 3000#

DRG.NO.: 4-381-21-03032

SHEET NO: 4 OF 13

REV.  
02

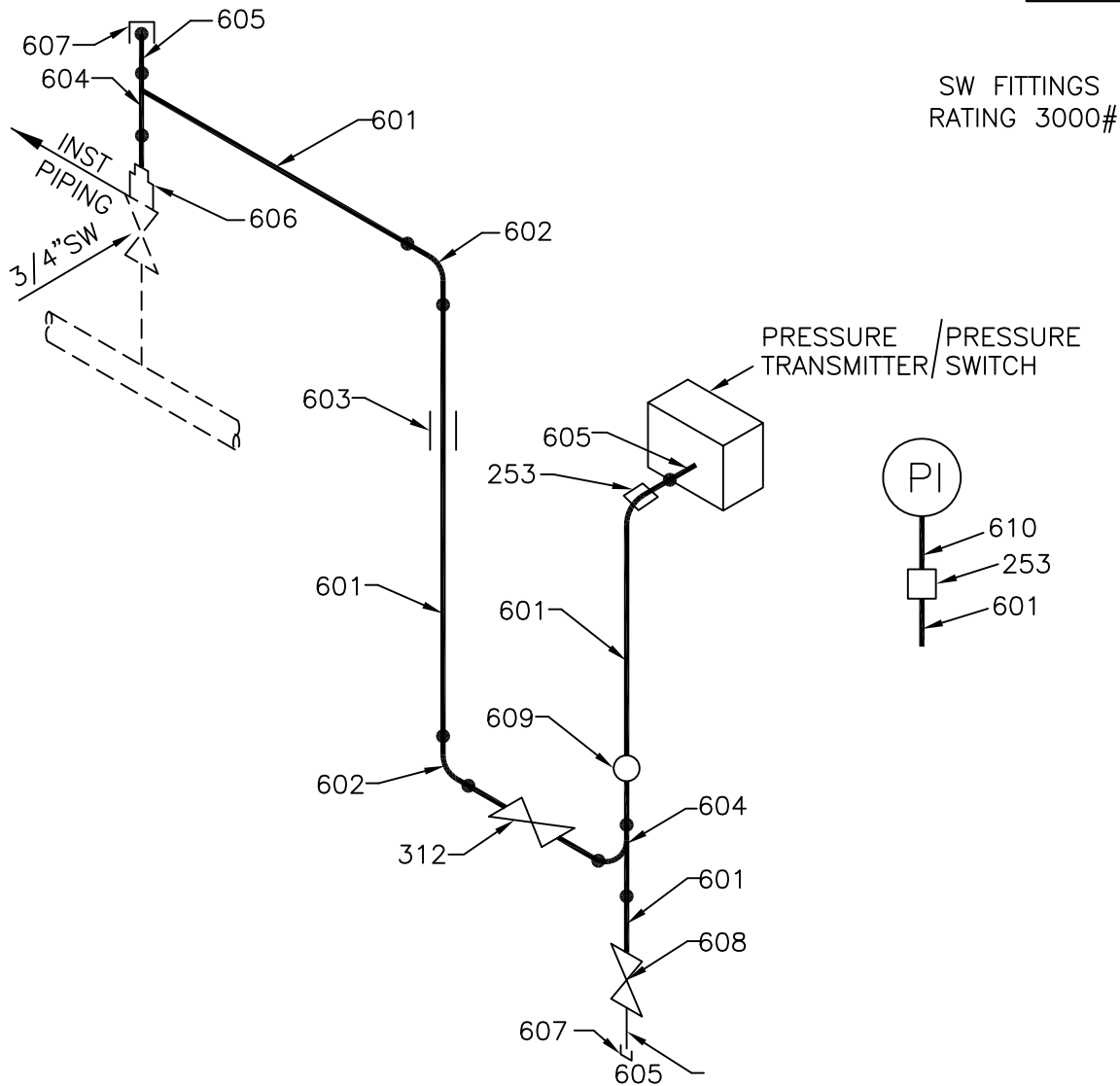

POS NO.	DESCRIPTION	MATERIAL CODE	SITE IDENTIFICATION
601	PIPE DIA 1/2" SCH 80 $\phi$ 21.3x2.8 SS	HY1071155623	39626002
602	ELBOW $\phi$ 1/2"SW SS	AA7242501229	39626002
603	COUPLING $\phi$ 1/2" SW SS	AA7242520223	39626002
604	T-UNION $\phi$ 1/2" SW-F SS	AA7242510228	39626002
605	NIPPLE L=100 $\phi$ 1/2" NPT/BW SS	HY7242578841	39626002
606	REDUCER NIPPLE $\phi$ 3/4"BWx1/2"BW SS	HY7242532442	39626002
607	CAP $\phi$ 1/2" NPT-F SS	HY7242579228	39626002
312	GLOBE VALVE $\phi$ 1/2" SW-F SS	AA7501478589	39626002
609	SYPHON 80S SW-F $\phi$ 1/2"SW-F SS	HY7316201649	39626002
610	ADAPTOR 1/2" BW / 1/2" NPT(F) SS	GT9757136018	39626002
253	DILO COUPLING $\phi$ 1/2"SW SS	TC9756105046	39626002

	STANDARD	TITLE:	DRG.NO.: 4-381-21-03032	
		PRESSURE GAUGE, PRESSURE TRANSMITTERS, PRESSURE SWITCH FOR STEAM APPLICATIONS(3000#)	SHEET NO: 5 OF 13	REV. 02

SW FITTINGS  
RATING 3000#

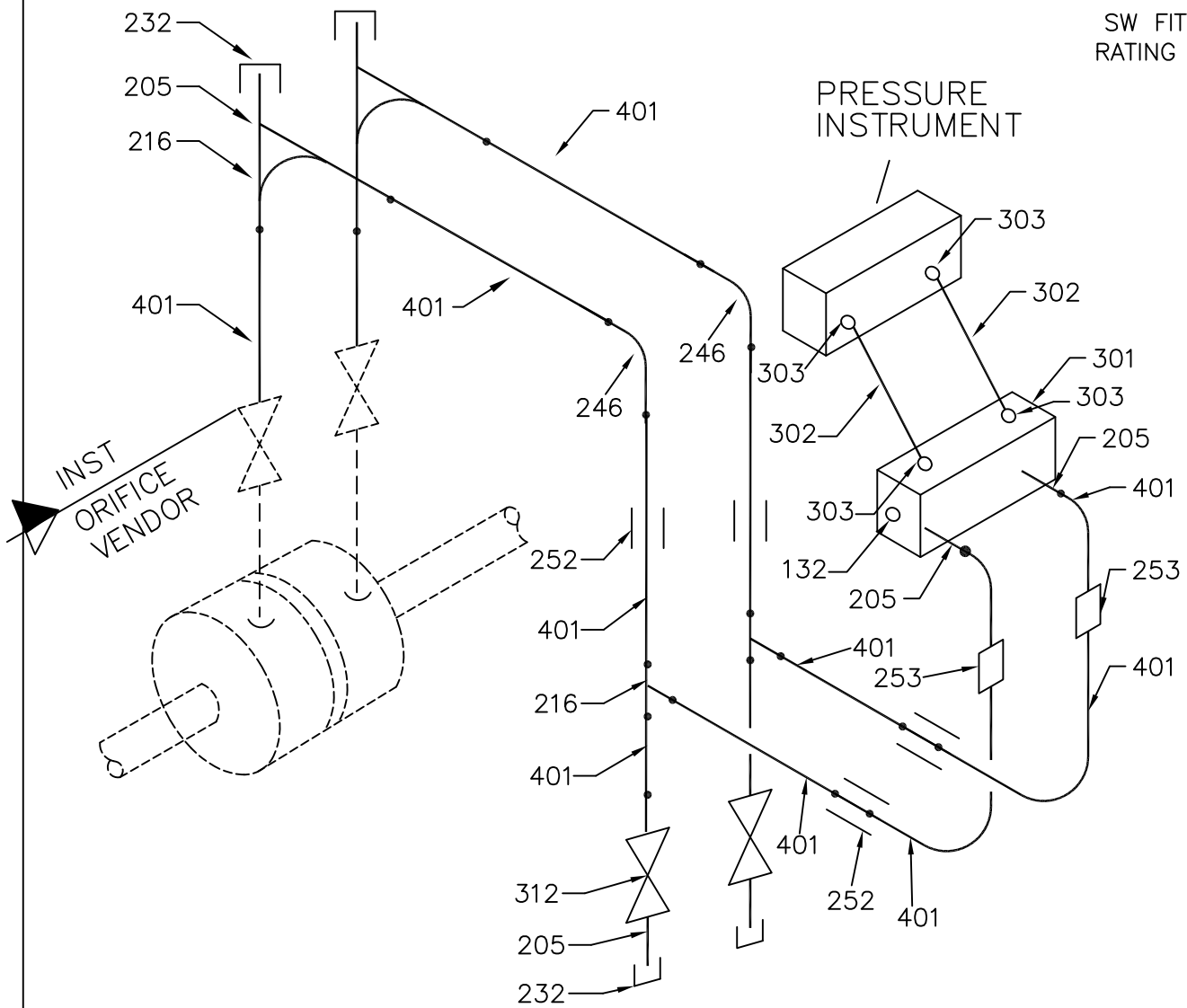

POS.NO.	ITEM DESCRIPTION AND SIZE	MATERIAL CODE	SITE IDENTIFICATION
401	PIPE DIA 1/2", $\phi$ 21.3/3.7 TP 321	HY1071055623	39626002
246	ELBOW $\phi$ 1/2"SW-F SS	AA7242501229	39626002
252	COUPLING $\phi$ 1/2"SW-F SS	AA7242520223	39626002
216	T-UNION $\phi$ 1/2"SW-F SS	AA7242510228	39626002
205	NIPPLE $\phi$ 1/2"BW/NPTM SS	HY7242578841	39626002
232	CAP $\phi$ 1/2"NPT-M SS	HY7242579228	39626002
312	GLOBE VALVE $\phi$ 1/2"SW-M SS	AA7501478589	39626002
301	5 WAY MANIFOLD $\phi$ 1/2"NPT-F SS	HY7316561017	39626002
253	DILO COUPLING $\phi$ 1/2"SW SS	TC9756105046	39626002
132	PLUG 1/2"NPT-M SS	HY7242584280	39626002
302	TUBE 12.7MM X 2.1MM SS	HY1071090054	39626002
303	MALE CONNECTOR 1/2" X1/2"NPT SS	TC9755501010	39626002



STANDARD

TITLE:

FLOW ORIFICE, FLOW NOZZLE  
FLOW VENTURI FOR AIR &  
WATER APPLICATIONS(3000#)

DRG.NO.: 4-381-21-03032

SHEET NO: 6 OF 13

REV.  
02

SW FITTINGS  
RATING 3000#

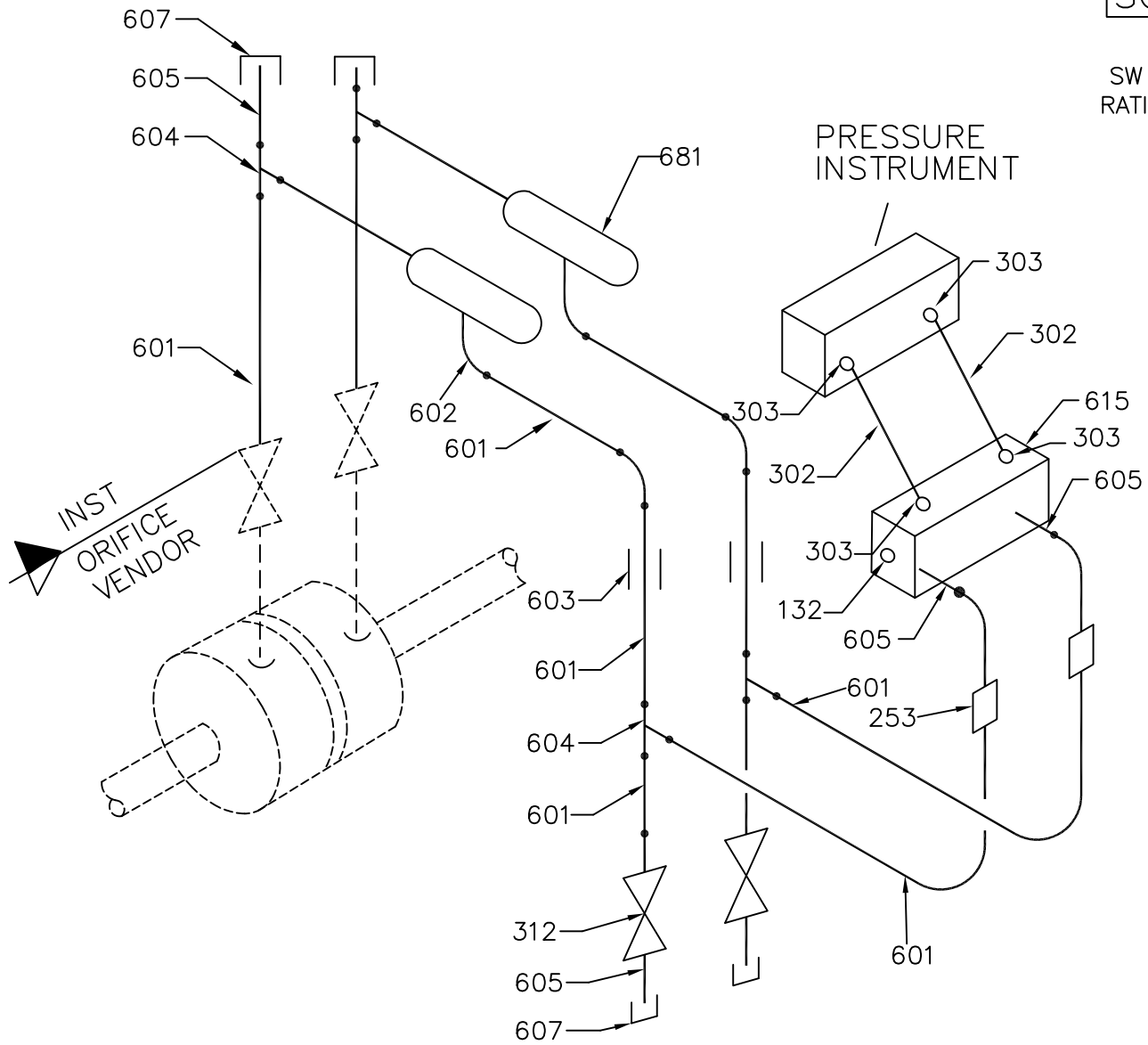

POS.NO.	ITEM DESCRIPTION AND SIZE	MATERIAL CODE	SITE IDENTIFICATION
601	PIPE DIA 1/2" SCH 160 $\phi$ 21/3X3.7 TP 321	HY1071055623	39626002
602	ELBOW $\phi$ 1/2"SW SS	AA7242501229	39626002
603	COUPLING $\phi$ 1/2"SW SS	AA7242520223	39626002
604	T-UNION $\phi$ 1/2"SW-F SS	AA7242510228	39626002
605	NIPPLE L-100 $\phi$ 1/2"NPT/BW SS	HY7242578841	39626002
607	CAP $\phi$ 1/2"NPT-F SS	HY7242579228	39626002
312	GLOBE VALVE $\phi$ 1/2"SW-F SS	AA7501478589	39626002
615	5 WAY MANIFOLD $\phi$ 1/2"NPT-F SS	HY7316561017	39626002
681	CONDENSATE POT $\phi$ 1/2"SW-F SS	TC9755535047	39626002
253	DILO COUPLING $\phi$ 1/2"SW SS	TC9756105046	39626002
132	PLUG $\phi$ 1/2"NPT-M SS	HY7242584280	39626002
302	TUBE 12.7MM X 2.1MM SS	HY1071090054	39626002
303	MALE CONNECTOR 1/2" X1/2"NPT SS	TC9755501010	39626002

	STANDARD	TITLE:	DRG.NO.: 4-381-21-03032
		FLOW ORIFICE, FLOW NOZZLE	SHEET NO: 7 OF 13
		FLOW VENTURI FOR STEAM APPLICATIONS(3000#)	

SW FITTINGS  
RATING 6000#

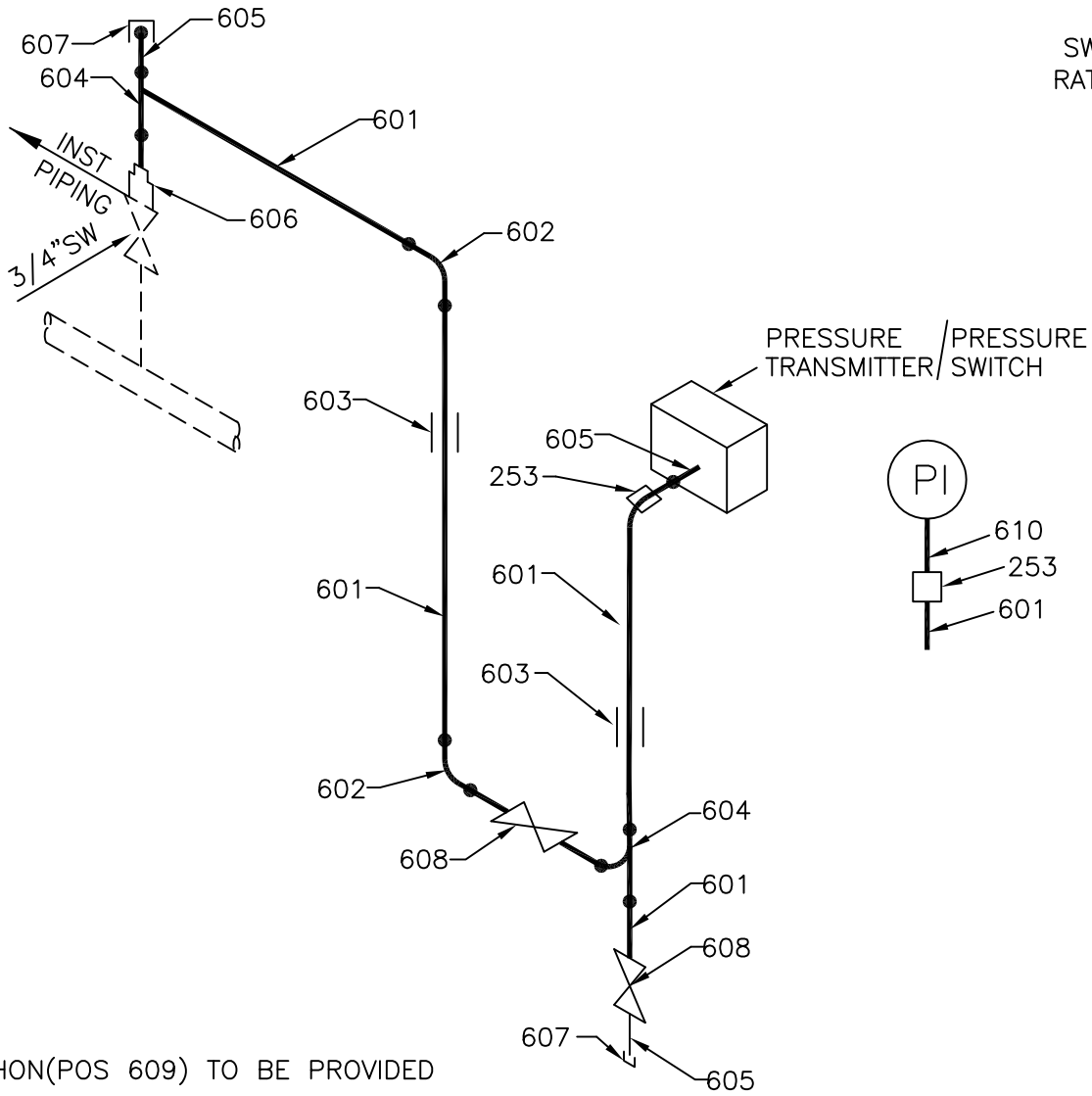

NOTE:SYPHON(POS 609) TO BE PROVIDED  
IN STEAM SERVICE APPLICATION ONLY.

POS.NO.	ITEM DESCRIPTION AND SIZE	MATERIAL CODE	SITE IDENTIFICATION
601	PIPE DIA 1/2" SCH 160 $\phi$ 21/3X4.8 SS	HY1071155741	39626002
602	ELBOW $\phi$ 1/2"SW SS	AA7242501490	39626002
603	COUPLING $\phi$ 1/2"SW SS	AA7242520495	39626002
604	T-UNION $\phi$ 1/2"SW-F SS	HY7242510228	39626002
605	NIPPLE L-100 $\phi$ 1/2"NPT/BW SS	HY7242578850	39626002
606	REDUCER NIPPLE $\phi$ 3/4"BWx1/2"BW SS	HY7242532566	39626002
607	CAP $\phi$ 1/2"NPT-F SS	HY7242579228	39626002
608	GLOBE VALVE $\phi$ 1/2"SW-F SS	AA7501538581	39626002
609	SYPHON 160S SE-F $\phi$ 1/2"SW-F SS	HY7316201657	39626002
610	ADAPTER 1/2"BW/1/2"NPT F SS	GT9757136018	39626002
253	COUPLING (DILO) $\phi$ 1/2"SW SS	TC9756105046	39626002



STANDARD

TITLE:  
PRESSURE GAUGE, PRESSURE  
TRANSMITTERS, PRESSURE SWITCH  
FOR AIR & WATER APPLICATION  
WITH 6000#

DRG.NO.: 4-381-21-03032

SHEET NO: 8 OF 13

REV.  
02

SW FITTINGS  
RATING 6000#

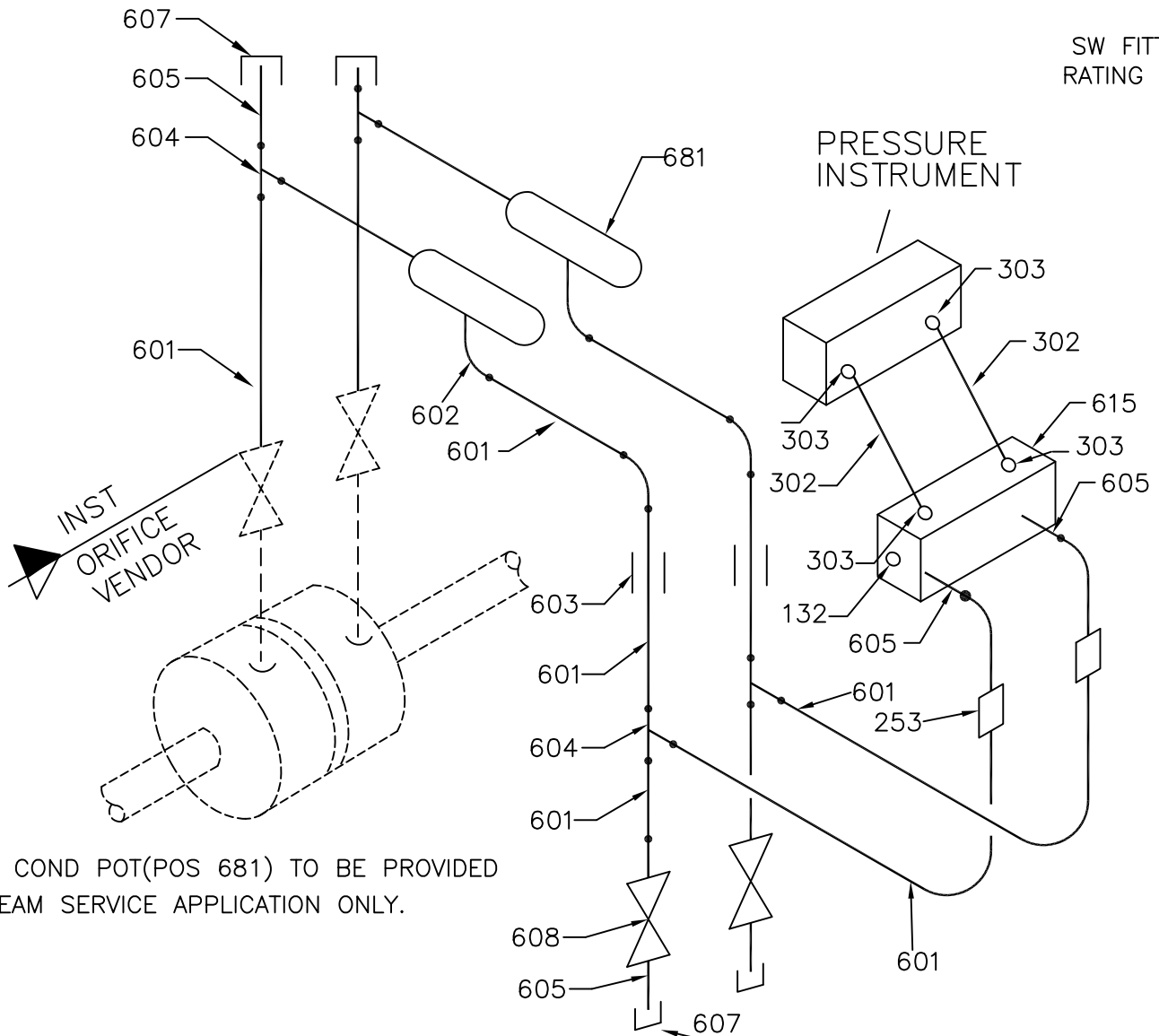

NOTE: COND POT(POS 681) TO BE PROVIDED  
IN STEAM SERVICE APPLICATION ONLY.

POS.NO.	ITEM DESCRIPTION AND SIZE	MATERIAL CODE	SITE IDENTIFICATION
601	PIPE DIA 1/2" SCH 160 $\phi$ 21.3X4.8 SS	HY1071155741	39616002
602	ELBOW $\phi$ 1/2"SW SS	AA7242501490	39626002
603	COUPLING $\phi$ 1/2"SW SS	AA7242520495	39626002
604	T-UNION $\phi$ 1/2"SW-F SS	HY7242510228	39626002
605	NIPPLE L-100 $\phi$ 1/2"NPT/BW SS	HY7242578850	39626002
607	CAP $\phi$ 1/2"NPT-F SS	HY7242579228	39626002
608	GLOBE VALVE $\phi$ 1/2"SW-F SS	AA7501538581	39626002
615	5 WAY MANIFOLD $\phi$ 1/2"NPT-F SS	HY7316561041	39626002
681	CONDENSATE POT $\phi$ 1/2"SW-F SS	TC9755535047	39626002
253	COUPLING(DILO) $\phi$ 1/2"SW SS	TC9756105046	39626002
132	PLUG $\phi$ 1/2"NPT-M SS	HY7242584280	39626002
302	TUBE 12.7MM X 2.1MM SS	HY1071090054	39626002
303	MALE CONNECTOR 1/2" X1/2"NPT SS	TC9755501010	39626002



STANDARD

TITLE:

FLOW ORIFICE, FLOW NOZZLE  
FLOW VENTURI FOR  
STEAM APPLICATIONS

DRG.NO.: 4-381-21-03032

SHEET NO: 9 OF 13

REV.  
02

SW FITTINGS  
RATING 6000#

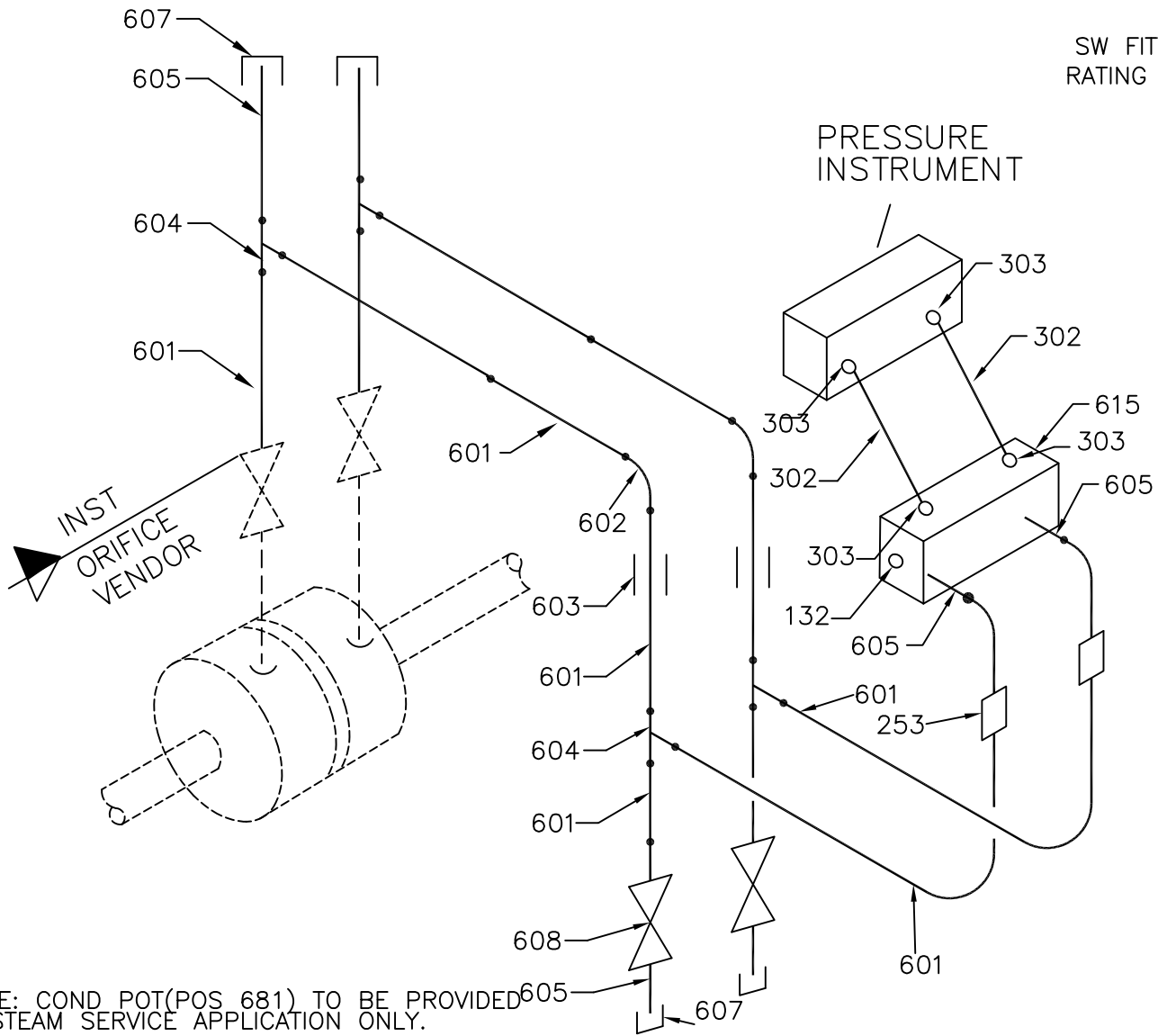

NOTE: COND POT(POS 681) TO BE PROVIDED IN STEAM SERVICE APPLICATION ONLY.

POS.NO.	ITEM DESCRIPTION AND SIZE	MATERIAL CODE	SITE IDENTIFICATION
601	PIPE DIA 1/2" SCH 160 $\phi$ 21.3X4.8 SS	HY1071155741	39616002
602	ELBOW $\phi$ 1/2"SW SS	AA7242501490	39626002
603	COUPLING $\phi$ 1/2"SW SS	AA7242520495	39626002
604	T-UNION $\phi$ 1/2"SW-F SS	HY7242510228	39626002
605	NIPPLE L-100 $\phi$ 1/2"NPT/BW SS	HY7242578850	39626002
607	CAP $\phi$ 1/2"NPT-F SS	HY7242579228	39626002
608	GLOBE VALVE $\phi$ 1/2"SW-F SS	AA7501538581	39626002
615	5 WAY MANIFOLD $\phi$ 1/2"NPT-F SS	HY7316561041	39626002
253	COUPLING(DILO) $\phi$ 1/2"SW SS	TC9756105046	39626002
132	PLUG $\phi$ 1/2"NPT-M SS	HY7242584280	39626002
302	TUBE 12.7MM X 2.1MM SS	HY1071090054	39626002
303	MALE CONNECTOR 1/2" X 1/2"NPT SS	TC9755501010	39626002



STANDARD

TITLE:

FLOW ORIFICE, FLOW NOZZLE  
FLOW VENTURI FOR  
WATER/AIR APPLICATIONS

DRG.NO.: 4-381-21-03032

SHEET NO: 10 OF 13

REV.  
02

SCHEME 8

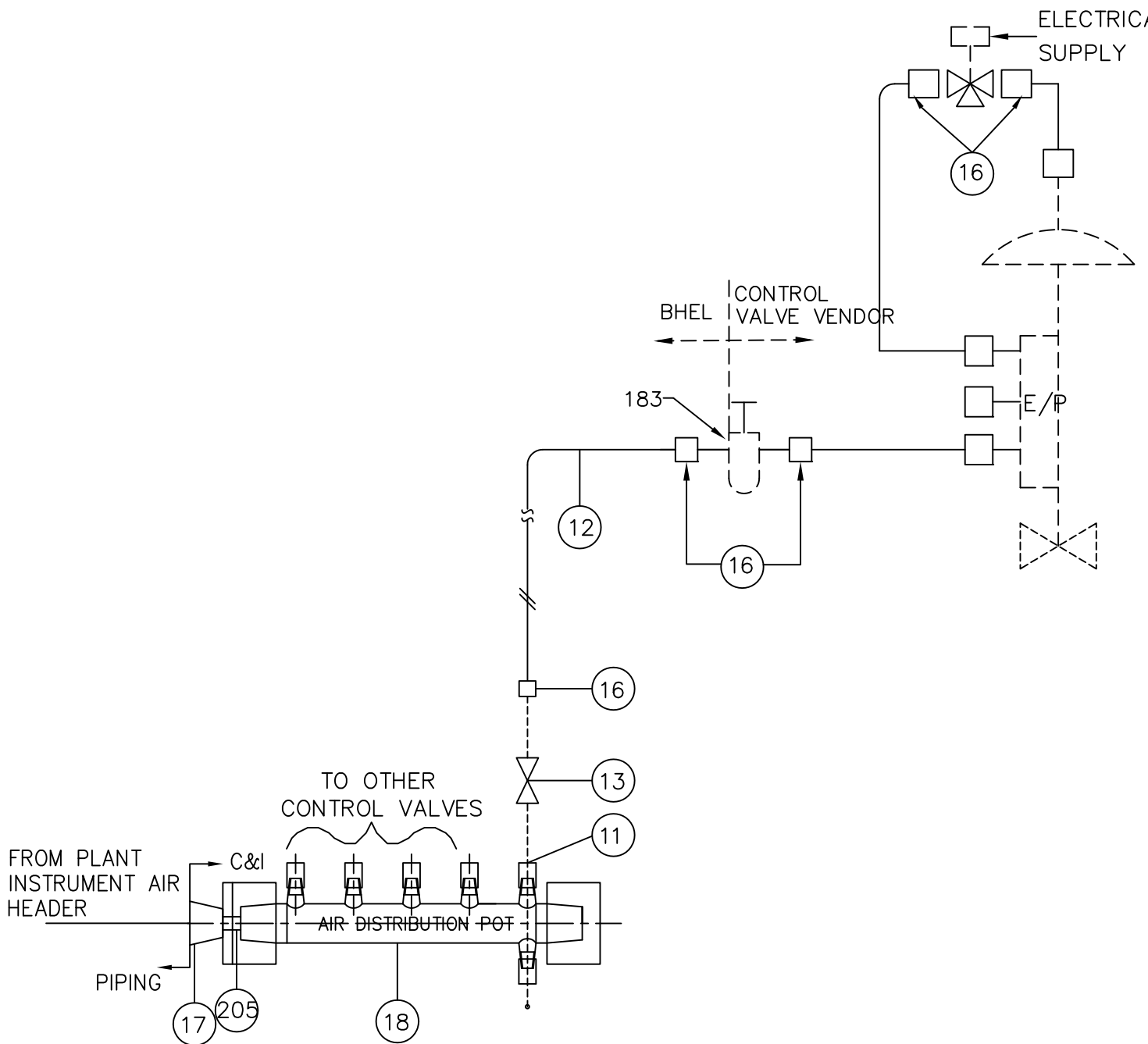

POS.NO.	ITEM DESCRIPTION AND SIZE	MATERIAL	SITE IDENTIFICATION
12	ø6mm x 1mm TUBE; ASTM A312TP321	HY1071155610	39626002
13	1/4" NEEDLE VALVE; SS	GT9757125016	39626002
16	MALE STUD COUPLING; 1/4"NPTxø6mm; SS	TC975558032	39626002
183	AIR FILTER REGULATOR	PART OF VALVE.	-
205	NIPPLE 1/2", NPTxBW	HY7242578841	39626002
17	REDUCER NIPPLE 1"x 1/2" BW	HY7242532531	39626002
11	FEMALE CONNECTOR ø6mmx1/4"NPT	GT9751038057	39626002
18	AIR DISTRIBUTION POT	TC9755557016	39626002

	STANDARD	TITLE: CONTROL VALVE WITH POSITIONER AND SOV APPLICATIONS	DRG.NO.: 4-381-21-03032	
			SHEET NO: 11 OF 13	REV. 02

PROJECT-LOKMANGAL MOULI/AGRO INDUSTRIES LTD.  
INSTRUMENT INSTALLATION DRAWINGS

S.No	Tag. No.	Service DESCRIPTION	P&ID No:	Medium	Operating Press (Kg/cm2)	Operating Temp. (°C)	Operating Flow (TPH)	Range From	Range To	C-C distance	Units	Line No / Equip No:	Type Of Inst.	Instru	Sheet No.
<b>STEAM FLOW (P&amp;ID- 2-38101-03571)</b>															
1	FT-5101	BOILER M5SV TO TURBINE FLOW	2-381-01-03571	STEAM	105	535	134.32	0	10000	NA	MMWC	OD 323.8X40 THK	DPT	FT	9 OF 13
2	FT-5201	TURBINE EXTRACT TO HP HEATER-2 FLOW	2-381-01-03571	STEAM	20.36	321.2	8.173	0	10000	NA	MMWC	OD 168.3X7.11 THK	DPT	FT	7 OF 13
3	FT-5301	TURBINE EXTRACT TO HP HEATER-1 FLOW	2-381-01-03571	STEAM	10.88	295.3	10.16	0	10000	NA	MMWC	OD 168.3X7.11 THK	DPT	FT	7 OF 13
4	FT-5401	TURBINE EXTRACT TO LP PROCESS & DEA FLOW	2-381-01-03571	STEAM	3	132.8	101.78	0	10000	NA	MMWC	OD 711X9.53 THK	DPT	FT	7 OF 13
5	DS-5401	DESUPERHEATER (LOOSE SUPPLY)	*	*	*	*	*	*	*	NA	*	*	DS	DS	11 OF 13
<b>CONDENSATE SYSTEM (P&amp;ID- 1-38101-04796)</b>															
6	PG-1641	COND TO SIAE PRESS	1-381-01-04796	Air+Steam	0.075	40	30.03	-1	1.5	NA	Kg/cm2	6"-VA-116-1622	Bourdon tube type	PG	4 OF 13
7	DPG-1608A	CEP-A PMP STRAINER DIFF PRESS	1-381-01-04796	Condensate	0.075	40	30.03	0	500	NA	MMWC	ACROSS STRAINER	Differential pr. Gauge	DPG	9 OF 13
8	DPSH-1609A	CEP-A PMP STRAINER DIFF PRESS SWITCH HIGH	1-381-01-04796	Condensate	0.075	40	30.03	0	500	NA	MMWC	ACROSS STRAINER	Differential pr. Switch	DPSH	6 OF 13
9	PG-1610A	CEP-A PMP INLET PRESS	1-381-01-04796	Condensate	0.075	40	30.03	-1	1.5	NA	Kg/cm2	6"-CS-116-1602A	Bourdon tube type	PG	4 OF 13
10	PG-1611A	CEP-A PMP DISCHARGE PRESS	1-381-01-04796	Condensate	9.5	40.4	30.03	0	25	NA	kg/cm2	CEP-A	Bourdon tube type	PG	4 OF 13
11	PSL-1642A	CEP-A PMP DISCHARGE PRESS SWITCH LOW	1-381-01-04796	Condensate	9.5	40.4	30.03	0	20	NA	Kg/cm2	CEP-A	Press. Switch	PS	4 OF 13
12	DPG-1608B	CEP-B PMP STRAINER DIFF PRESS	1-381-01-04796	Condensate	0.075	40	30.03	0	500	NA	MMWC	ACROSS STRAINER	Differential pr. Gauge	DPG	6 OF 13
13	DPSH-1609B	CEP-B PMP STRAINER DIFF PRESS SWITCH HIGH	1-381-01-04796	Condensate	0.075	40	30.03	0	500	NA	MMWC	ACROSS STRAINER	Differential pr. transmitter	DPSH	6 OF 13
14	PG-1610B	CEP-B PMP INLET PRESS	1-381-01-04796	Condensate	0.075	40	30.03	-1	1.5	NA	Kg/cm2	6"-CS-116-1602C	Bourdon tube type	PG	4 OF 13
15	PG-1611B	CEP-B PMP DISCHARGE PRESS	1-381-01-04796	Condensate	9.5	40.4	30.03	0	25	NA	kg/cm2	CEP-B	Bourdon tube type	PG	4 OF 13
16	PSL-1642B	CEP-B PMP DISCHARGE PRESS SWITCH LOW	1-381-01-04796	Condensate	9.5	40.4	30.03	0	20	NA	Kg/cm2	CEP-B	Press. Switch	PS	4 OF 13
17	DPG-1608C	CEP-C PMP STRAINER DIFF PRESS	1-381-01-04796	Condensate	0.075	40	30.03	0	500	NA	MMWC	ACROSS STRAINER	Differential pr. Gauge	DPG	6 OF 13
18	DPSH-1609C	CEP-C PMP STRAINER DIFF PRESS SWITCH HIGH	1-381-01-04796	Condensate	0.075	40	30.03	0	500	NA	MMWC	ACROSS STRAINER	Differential pr. transmitter	DPSH	6 OF 13
19	PG-1610C	CEP-C PMP INLET PRESS	1-381-01-04796	Condensate	0.075	40	30.03	-1	1.5	NA	Kg/cm2	6"-CS-116-1602C	Bourdon tube type	PG	4 OF 13
20	PG-1611C	CEP-C PMP DISCHARGE PRESS	1-381-01-04796	Condensate	9.5	40.4	30.03	0	25	NA	kg/cm2	CEP-C	Bourdon tube type	PG	4 OF 13
21	PSL-1642C	CEP-C PMP DISCHARGE PRESS SWITCH LOW	1-381-01-04796	Condensate	9.5	40.4	30.03	0	20	NA	Kg/cm2	CEP-C	Press. Switch	PS	4 OF 13
22	PSL-1612	CEP DISCHARGE HEADER PRESS SWITCH LOW	1-381-01-04796	Condensate	9.5	40.4	30.03	0	20	NA	Kg/cm2	6"-CD-1608(11C)	Press. Switch	PS	4 OF 13
23	PT-1613	CEP DISCHARGE HEADER PRESS	1-381-01-04796	Condensate	9.5	40.4	30.03	0	25	NA	Kg/cm2	6"-CD-1608(11C)	Smart electronic pr. Transmitter	PT	4 OF 13
24	PG-1643	CEP DISCHARGE HEADER PRESS	1-381-01-04796	Condensate	9.5	40.4	30.03	0	25	NA	Kg/cm2	6"-CD-1608(11C)	Bourdon tube type	PG	4 OF 13
25	PG-1617	SJAE-1 OIL PRESS	1-381-01-04796	steam	9.5	40.4	30.03	0	25	NA	Kg/cm2	6"-CD-1608(11C)	Bourdon tube type	PG	4 OF 13
26	PG-1618	SJAE-1 OIL PRESS	1-381-01-04796	Condensate	8.5	52.7	30.03	0	16	NA	Kg/cm2	6"-CD	Bourdon tube type	PG	4 OF 13
27	PG-1621	SJAE-2 OIL PRESS	1-381-01-04796	Condensate	9.5	40.4	30.03	0	25	NA	Kg/cm2	6"-CD-1609	Bourdon tube type	PG	4 OF 13
28	PG-1622	SJAE-2 OIL PRESS	1-381-01-04796	Condensate	8.5	52.7	30.03	0	16	NA	Kg/cm2	6"-CD-1610	Bourdon tube type	PG	4 OF 13

PROJECT-LOKMANGAL MOULI/AGRO INDUSTRIES LTD.  
INSTRUMENT INSTALLATION DRAWINGS

S.No	Tag. No.	Service DESCRIPTION	P&ID No:	Medium	Operating Press (Kg/cm2)	Operating Temp. (°C)	Operating Flow (TPH)	Range From	Range To	C-C distance	Units	Line No / Equip No:	Type Of Inst.	Instru	Sheet No.
29	PG-1636	SJEA-2 PRESSURE	1-381-01-04796	Condensate	0.075	40	*	-1	1.5	NA	Kg/cm2	SJAE-2	Bourdon tube type	PG	4 OF 13
30	PG-1637	SJEA-1 PRESSURE	1-381-01-04796	Condensate	0.075	40	*	-1	1.5	NA	Kg/cm2	SJAE-1	Bourdon tube type	PG	4 OF 13
31	PG-1634	AUX STEAM TO SJAEA PRESS	1-381-01-04796	Condensate	9	300	0.65	0	25	NA	Kg/cm2	88.9X5.49	Bourdon tube type	PG	4 OF 13
32	PG-1624	GLAND STEAM COND ILPRESS	1-381-01-04796	condensate	8.5	52.7	30.03	0	16	NA	Kg/cm2	168.3X7.11	Bourdon tube type	PG	4 OF 13
33	PG-1629	GLAND STEAM COND OIL PRESS	1-381-01-04796	condensate	7.2	53.6	30.03	0	16	NA	Kg/cm2	168.3X7.11	Bourdon tube type	PG	4 OF 13
34	PT-1646	GLAND STEAM COND OIL HEADER PRESS	1-381-01-04796	condensate	7.2	53.6	30.03	0	16	NA	Kg/cm2	168.3X7.11	Smart electronic pr. Transmitter	PT	4 OF 13
35	PG-5665	AUX STEAM TO GSC PRESS	1-381-01-04796	steam	9	300	0.1	0	25	NA	Kg/cm2	--	Bourdon tube type	PG	5 OF 13
36	PG-5664	EJECTORS TO GSC PRESS.	1-381-01-04796	Air+Condensate	0.075	40	30.03	-1	1.5	NA	Kg/cm2	ON EJECTOR LINE	Bourdon tube type	PG	4 OF 13
37	PG-5663	GSC PRESS.	1-381-01-04796	condensate	12	48	49.1 Kg/hr	0	25	NA	Kg/cm2	ON GSC	Bourdon tube type	PG	4 OF 13
38	LCV-1603A	HOTWELL LEVEL CONTROL VALVE	1-381-01-04796	condensate	5.7	53.6	30.03	NA	NA	NA	NA	6"-CD-11C	control valve with pneumatic actuator	CV	11 OF 13
39	FCV-1648	HOTWELL CONDENSATE MINM. RECIRC. LEVEL CNTRL VLV	1-381-01-04796	condensate	7.2	53.6	--	NA	NA	NA	NA	3"-CD-11C	control valve with pneumatic actuator	CV	11 OF 13
40	LCV-1603C	HOTWELL LEVEL CONTROL VALVE	1-381-01-04796	condensate	5.7	53.6	--	NA	NA	NA	NA	6"-CD-11C	control valve with pneumatic actuator	CV	11 OF 13
41	PG-1631	SJAE TO DEAERATOR PRESS GUAGE	1-381-01-04796	Condensate	5.7	53.6	30.03	0	16	NA	Kg/cm2	6"-CD-1611(11C)	Bourdon tube type	PG	4 OF 13
42	PT-1632	SJAE TO DEAERATOR PRESS	1-381-01-04796	Condensate	5.7	53.6	30.03	0	16	NA	Kg/cm2	6"-CD-1611(11C)	Smart electronic pr. Transmitter	PT	4 OF 13
43	FT-1633	SJAE TO DEAERATOR FLOW	1-381-01-04796	Condensate	5.7	53.6	30.03	0	10000	NA	MMWC	6"-CD-1611(11C)	Differential pr. Transmitter	FT	6 OF 13
<b>IA DISTRIBUTION SYSTEM (P&amp;ID- 4-38101-03071)</b>															
44	PG-6202	INSIDE THE TG HALL PRESS.	4-38101-03071	AIR	5	48	30	0	10	NA	Kg/cm2	2"-IA--11E-6201	Bourdon tube type	PG	4 OF 13
45	PT-6201	INSIDE THE TG HALL PRESS.	4-38101-03071	AIR	5	48	30	0	10	NA	Kg/cm2	2"-IA--11E-6201	Smart electronic pr. Transmitter	PT	4 OF 13
<b>HP HEATER(LOOSE ITEM SUPPLY)</b>															
46	PG-1650	HP HEATER-1 INLET STEAM PRESS.	*	STEAM	10.88	*	*	0	25	NA	Kg/cm2	*	Bourdon tube type	PG	5 OF 13
47	PG-1652	HP HEATER-1 DRAIN PRESS.	*	condensate	11	*	*	0	25	NA	Kg/cm2	*	Bourdon tube type	PG	4 OF 13
48	PG-1654	HP HEATER-1 FEED WATER INLET PRESS.	*	WATER	120	*	*	0	160	NA	Kg/cm2	*	Bourdon tube type	PG	4 OF 13
49	PG-1656	HP HEATER-1 FEED WATER OUTLET PRESS.	*	WATER	120	*	*	0	160	NA	Kg/cm2	*	Bourdon tube type	PG	4 OF 13
50	PG-1658	HP HEATER-1 SHELL PRESSURE	*	condensate	20	*	*	0	40	NA	Kg/cm2	ON SHELL	Bourdon tube type	PG	4 OF 13
51	PG-1659	HP HEATER-1 SHELL PRESSURE	*	condensate	20	*	*	0	40	NA	Kg/cm2	ON SHELL	Bourdon tube type	PG	4 OF 13
52	PG-1660	HP HEATER-2 INLET STEAM PRESS.	*	STEAM	20.36	*	*	0	40	NA	Kg/cm2	*	Bourdon tube type	PG	5 OF 13
53	PG-1662	HP HEATER-2 DRAIN PRESS.	*	condensate	21	*	*	0	40	NA	Kg/cm2	*	Bourdon tube type	PG	4 OF 13
54	PG-1664	HP HEATER-2 FEED WATER INLET PRESS.	*	WATER	120	*	*	0	160	NA	Kg/cm2	*	Bourdon tube type	PG	4 OF 13
55	PG-1666	HP HEATER FEED-2 WATER OUTLET PRESS.	*	WATER	120	*	*	0	160	NA	Kg/cm2	*	Bourdon tube type	PG	4 OF 13
56	PG-1668	HP HEATER-2 SHELL PRESSURE	*	condensate	21	*	*	0	40	NA	Kg/cm2	ON SHELL	Bourdon tube type	PG	4 OF 13
57	PG-1669	HP HEATER-2 SHELL PRESSURE	*	condensate	21	*	*	0	40	NA	Kg/cm2	ON SHELL	Bourdon tube type	PG	4 OF 13