

Ref: BHE/PW/PUR/TPT-CRN/1203/Corrigendum 01

Date 07/12/2013

Page 1 of 1

To

ALL BIDDERS

**Sub:** Corrigendum -01 issue of Clarification

**JOB: TRANSPORTATION OF KOBELCOCKE 2500-II CRAWLER CRANE OF 250 MT CAPACITY FROM BHEL SITE, UKAI (GUJRAT) TO BHEL SITE, NTPC Mauda (Maharashtra).**

**Tender Specification Number: BHE/PW/PUR/TPT-CRN/1203/OJ**

Bidders to kindly take note of the following:

=====  
**AA) Issue of Clarification.**

**Query 1:** Refer Annexure –A (Loading Plan).Wherein the master assembly and Master assembly are to be transported in single trailer. However the height of Carbody is 11.55 ft and of Master assembly 3.4 ft. Also in case of Length the former is 31.7 ft and the latter is 33.79 ft. Hence to transport the master assembly a separate trailer is needed. Kindly confirm.

**Clarification 1:** The Upper Machine with Car Body, wire rope and Mast assembly are to be transported in assembled condition. The net height of the assembled consignment is 3.4 meter (11.15 ft), Length is 12.235 meter (40.14 ft) and width is 3.4 meter (11.15 ft). Hence the tender specification shall remain same. (See the Pic. below).

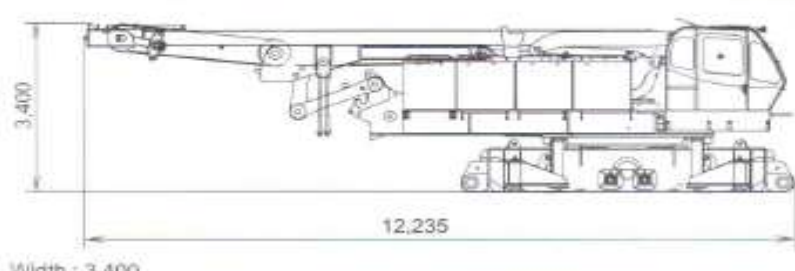
Name	Dimension (mm)	Weight kg
Base Machine	 3,400 12,235 Width : 3,400	44,900

=====  
All other Terms and conditions of the Tender Specification shall remain unaltered unless expressly amended by BHEL in writing.

Bidders are requested to submit a copy of this corrigendum duly countersigned by the authorized signatory and stamped with the Official seal as a token of Bidder's unqualified acceptance of this corrigendum.

This letter is hosted as file titled "Corrigendum-01" against NIT-15706 in BHEL web page (www.bhel.com→Tender Notifications → View Corrigendum).

Thanking you,  
Yours faithfully,

**AGM (Purchase)**