

TAMIL NADU GENERATION AND DISTRIBUTION COMPANY

2 X 660 MW ENNORE SEZ STPP

TECHNICAL SPECIFICATION
FOR
CONTROL VALVES WITH ACCESSORIES
(Pneumatically Operated)

VOLUME II-B & III

REV 01

SPECIFICATION No: PE-TS-412-145-I 104



BHARAT HEAVY ELECTRICALS LIMITED
POWER SECTOR
PROJECT ENGINEERING MANAGEMENT DIVISION
NOIDA, INDIA

1.0 The tender document contains three (3) volumes. The bidder shall meet the requirements of all the three volumes.

1.1 **Volume-I (CONDITIONS OF CONTRACT)**

This consists of four parts as below :-

- Volume-IA : This part contains instructions to bidders for making bids to BHEL.
- Volume-IB : This part contains general commercial conditions of the tender & includes provision that vendor is responsible for the quality of item supplied by their sub-vendors.
- Volume-IC : This part contains special conditions of contract.
- Volume-ID : This part contains commercial conditions for erection & commissioning site work, as applicable.

1.2 **Volume-II TECHNICAL SPECIFICATIONS**

Technical requirements are stipulated in Volume-II which comprises of :-

- Volume-IIA : General Technical Conditions
- Volume-IIB : Technical Specification including Drawings, if any.

1.2.1 **Volume-IIB**

This volume is sub-divided into following sections :-

- Section-A : This section outlines the scope of enquiry.
- Section-B : This section provides "Project Information".
- Section-C : This section indicates technical requirements specific to the contract, not covered in Section-D.
- Section-D : This section comprises of technical specifications of equipments complete with data sheet A, B and C.

Data Sheet - A specifies data and other requirements pertaining to the Equipment.

Data Sheet - B Specifies data to be filled by the bidder (Data Sheet-B is contained in Volume-III).

Data Sheet - C Indicates data/documents to be furnished after the award of contract as per agreed schedule by the vendor (as applicable).

1.2.2 **Volume-III TECHNICAL SCHEDULES**

This volume contains technical schedules and Data Sheets-B, which are to be duly filled by the bidder and the same shall be furnished with the technical bid as per instructions given in Document No. PE-SS-999-100-Q-002 in Volume-III.

2.0 The requirements mentioned in Section-C / Data Sheets-A of section-D shall prevail and govern in case of conflict between the same and the corresponding requirements mentioned in the descriptive portion in Section-D.

**PREPARED BY
VM RAO, DGM (Q)**

**APPROVED BY :
RAJIVA K SOOD, AGM & MR**

SDM_files labelled.doc

TAMIL NADU GENERATION AND DISTRIBUTION COMPANY

2 X 660 MW ENNORE SEZ STPP

TECHNICAL SPECIFICATION
FOR
CONTROL VALVES WITH ACCESSORIES
(Pneumatically Operated)

VOLUME II-B & III

SPECIFICATION No: PE-TS-412-145-I 104



BHARAT HEAVY ELECTRICALS LIMITED
POWER SECTOR
PROJECT ENGINEERING MANAGEMENT DIVISION
NOIDA, INDIA

PREPARED BY: RAHUL VARSHNEY Sr. Engr. (C & I)	CHECKED BY: CHETAN MALIK Dy. Mgr. (C & I)	APPROVED BY: SURESH CHAND SHARMA Sr. Mgr. (C & I)
--	--	--

	<p>Technical specification for Control Valves with Accessories (Pneumatically Operated) 2 X 660 MW ENNORE SEZ STPP</p>	SPECIFICATION NO. PE-TS-412-145-I104	
		VOLUME II-B	
		SECTION	
		REV. NO. 01	DATE: 03.09.15
		SHEET 4	OF 135

CONTENTS

VOL-II B

SECTION	DESCRIPTION	PAGE NO.
A	Scope of Enquiry	5
B	Project Information	7
C	Specific Technical Requirements	9
	Hook up Diagram	41
D	Specification for Control Valves	
	- Equipment Specification (PES – 145 – 06)	45
	- Spec. for Microprocessor Based Electronic Positioner(SMART) (PES – 145 – 06A)	45
	- Data sheets A & B for Control Valves (Data sheet no. PES-145-06-DS1-0)	62
	- Data sheets A & B for Accessories(Modulating & ON/OFF Duty) (Data sheet no. PES-145-06-DS1-0)	107
	- Data sheets C for Control Valves (Data sheet no. PES-145-06-DS2-0)	109
	- Quality Plan for Control Valves. (No.PE-QP-375-145-I104)	112
	- Bill of Quantity for Control Valves.	119
	- Spares.	122
	- Sub-Vendor List	124



Technical specification for
Control Valves with Accessories
(Pneumatically Operated)
2 X 660 MW ENNORE SEZ STPP

SPEC NO.: PE-TS-412-145-I 104

VOLUME II B

SECTION A

REV. NO. 01

DATE 03.09.15

SHEET

5

OF

135

SECTION – A
SCOPE OF ENQUIRY



Technical specification for
Control Valves with Accessories
(Pneumatically Operated)
2 X 660 MW ENNORE SEZ STPP

SPEC NO.: PE-TS-412-145-I 104

VOLUME II B

SECTION A

REV. NO. 01

DATE 03.09.15

SHEET 6

OF 135

SCOPE OF ENQUIRY

1. SCOPE

- 1.1 This specification covers the Design, Manufacture, Inspection and Testing at manufacturer's works, proper packing for transportation and delivery to site of the **Control Valves with Pneumatic Actuator along with Accessories, Start-up/Commissioning and Mandatory Spares** as mentioned in different sections of this specification for **2X660 MW ENNORE SEZ STPP**
- 1.2 The quality plan enclosed forms the minimum requirement but not limited to be adhered to by the bidder. Bidder to sign and stamp the same and submit along with the offer as an acceptance.
- 1.3 **Bidder to note that Cv test is required to be conducted on one type per size, Cv value. Bidder to group such valves and indicate the same along with the price bid. Unpriced portion to be submitted along with the bid.**
- 1.4 Following signed & stamped documents with company seal to be submitted by bidder.
- a) Complete offer including calculation sheets, catalogues etc.
 - b) Quality Plan
 - c) Datasheet A & B, duly filled
 - d) Schedule of prices & unit prices, inspection schedule
 - e) Schedule of submission of drawings/documents, equipment manufacture, inspection & dispatch.

2 GENERAL TECHNICAL INSTRUCTIONS

- 2.1 It is not the intent here to specify all the details of design and manufacture. However, the equipment shall conform in all respects to high standard of design, engineering and workmanship and shall be capable of performing the required duties in a manner acceptable to the customer / consultant, who will interpret the meaning of drawing and specification and shall be entitled to reject any component or material which in his judgment is not in full accordance herewith.
- 2.2 The omission of specific reference to any component / accessory necessary for the proper performance of the equipment shall not relieve the supplier of the responsibility of providing such facilities to complete the supply within the quoted prices.
- 2.3 BHEL' s / Customer' s representatives shall be given access to the shop in which the equipment are being manufactured or tested and all test records shall be made available to them.
- 2.4 The Equipment covered under this specification shall not be dispatched unless the same have been finally inspected, accepted and Material Dispatch Clearance Certificate (MDCC) is issued by BHEL / Customer.



Technical specification for
Control Valves with Accessories
(Pneumatically Operated)
2 X 660 MW ENNORE SEZ STPP

SPEC NO.: PE-TS-412-145-I 104

VOLUME II B

SECTION B

REV. NO. 01

DATE : 03.09.15

SHEET 7 OF 135

SECTION – B

PROJECT INFORMATION

PROJECT SYNOPSIS GENERAL BACKGROUND AND SALIENT FEATURES

1.1 Introduction

Tamilnadu Generation and Distribution Corporation owns the proposed green-field 1320 MW (2 units of 660 MW each) Coal Based Thermal Power Station at Katupalli. This is an expansion of North Chennai Thermal Power Station (NCTPS) and located on some portion of the ashdyke of NCTPS.

1.2 Location

The proposed site for main power plant is located near Ennore port (approx 5 kms).

The nearest Railway station is at Ashipattu Pudunagar (approx 5 kms)

All weather road from Pattamandri on the Thiruvottiyur-Ponneri district highway is the nearest road access.

The nearest airport is at Chennai at a distance of 60 km.

1.3 Type of Plant

The proposed 2x660 MW Super-Critical Power Project consists of coal fired steam generator connected to a reheat type steam turbine generator along with all the required auxiliaries. Circulating cooling water system is envisaged for condenser cooling. The description and salient technical data of the Steam Generator, Steam Turbine Generator, Auxiliary systems, Electrical, Control & Instrumentation, Civil etc. are explained elsewhere in the specification:

1.4 PROJECT INFORMATION

Project Title : **2 x 660 MW Ennore SEZ Coal Based Supercritical Thermal Power Project at Ash Dyke of NCTPS** DESEIN Volume-II: General & Schedules General Background and Salient Features 2 x 660 MW Ennore SEZ Supercritical Thermal Power Project at Ash Dyke of NCTPS.

Owner : **TAMIL NADU GENERATION AND DISTRIBUTION CORPORATION (TANGEDCO)**

LOCATION

The site is located near Vayalur Village, Ennore

Latitude : 13⁰17' N to 13⁰18' N

Longitude : 80⁰18' E to 80⁰19' E

Distance from Chennai City : 35 km

Nearest Airport is at Chennai at a

Distance of : 60 km

Nearest Seaport is : Ennore

Nearest Railway Station is : Athipattu Pudunagar (approx 5 kms)

Meteorological Condition

Climate : Tropical ,very dry and hot summer, dry and cold winter and good rain-fall in monsoon accompanied with strong wind.

Climatological data : Ambient temp. (°C)
Annual Maximum Mean Temp 41.5(°C)
Annual Minimum Mean Temp 24(°C)
Design Ambient temperature 35(°C)

Relative Humidity

Maximum 100%

Minimum 36%

Design 75%

Annual Rainfall

Maximum 2540 mm

Average 1600 mm

Minimum 1175 mm

Prevailing Wind Direction

Nov to Jan – From NW & NE

Feb to Mar – From East & SE
Apr to May – From South & SE
June – From SW
July to Aug – From NW
Sept to Oct – From SE & SW
Wind Speed 11.8 kmph (avg)
50 kmph (max)
Seismic Zone III as per
IS:1893-2002

1.5 Access to Site

Site is well connected to all weather road from Pattamandri on the Thiruvottiyur – Ponneri district highway. Site is located adjacent to the Chennai – Howrah broad gauge line and thus well connected by rail also.

1.6 Plant Rating, Capacity, Availability, PLF

Each of the two units shall have a Turbine maximum continuous rating (TMCR) of 660 MW at generator terminals based on the following site conditions.

- Ambient air temperature
- Condenser cooling water inlet temperature of 33°C and 9°C temperature rise across the condenser.
- Generator power factor of 0.85.
- Fuel specification as given elsewhere.
- Design temperature for electrical equipment is 50°C.

The VVO capacity of the steam turbine shall not be less than 105% of TMCR flow at rated parameters. Boiler maximum Continuous Rating (BMCR) will be established to match the steam flow at VVO conditions, but BMCR flow shall not less than 108% of TMCR flow.

The capacity of the unit is selected so as to deliver the rated output even after ageing that will occur between overhauls, as a result of deposition of salts in turbine blades, wear and tear etc.

The plant load factor (PLF) being considered is 85%.



Technical specification for
Control Valves with Accessories
(Pneumatically Operated)
2 X 660 MW ENNORE SEZ STPP

SPEC NO.: PE-TS-412-145-I 104

VOLUME II B

SECTION C

REV. NO. 01

DATE 03.09.15

SHEET 9 OF 135

SECTION-C

SPECIAL TECHNICAL REQUIREMENT



Technical specification for
Control Valves with Accessories
(Pneumatically Operated)
2 X 660 MW ENNORE STPP

SPEC NO.: **PE-TS-412-145-I 104**

VOLUME **II-B**

SECTION **C**

REV. NO. 01

DATE: 03.09.15

SHEET 10

OF 135

SPECIFIC TECHNICAL REQUIREMENTS

The requirements in this section are specific for this project and shall over-ride the specification under Section-D in case of any contradiction. However In case of any contradiction between this SPECIFIC TECHNICAL REQUIREMENTS and customer SPECIFICATION attached further, the more stringent specification shall prevail and BHEL's decision shall be final.

- 1) Bidder to note that data sheet-B, Format "Schedule of submission of Drawings/ Documents, Equipment Manufacture, Inspection and Despatch" enclosed in Section-D, to be signed and stamped and submitted with the bid. Quality Plan enclosed in Volume-IIB should be furnished duly signed and stamped. NO DEVIATION IS ACCEPTABLE.
- 2) All the formats in Volume-III should be filled-up and furnished with the bid, complete in all respect. Catalogue, Leaflets related with the models of Control Valves as well as each Accessory must be furnished with the offer. In the absence of those, the bid would be considered incomplete and shall be liable for rejection. Catalogue, Leaflets related with the models of Control Valves as well as each accessory must be furnished with the offer.
- 3) The Hook-up diagram for Control valve is attached in Section-C. The Bidder's scope starts from isolation valve at Inst. Air Supply header. The suitable connector required for connection of pneumatic tubing to isolation valve at Instrument Air Header is also in bidder's scope.
- 4) Valve Body Sizes shall be quoted to take care of the specification requirements like parameters, and limitations of Fluid outlet velocities, Noise Level etc. **However Port (Trim) Sizes shall be selected to suit CV requirement for achieving percentage valve lift as per Technical specification.**
- 5) Type of bonnet shall be according to the service condition. Extension bonnets shall be provided when the maximum temperature of the flowing fluid is greater than 275 Deg C.
- 6) Valve and actuator shall be designed for full differential pressure (Max. shut-off pressure).
- 7) Tolerances on end to end, center to center, center to face shall be in accordance with ASME B16.10.
- 8) Anti-cavitation trims shall be provided for valves with cavitation services and hardened trims for flashing services.
- 9) Valve type like cavitation/flashing/ high DP has been indicated in the data sheet. Bidder to offer the valve accordingly. However if process is cavitating, although not indicated in the valve type, bidder to offer Anti-cavitation trim.



Technical specification for
Control Valves with Accessories
(Pneumatically Operated)
2 X 660 MW ENNORE STPP

SPEC NO.: **PE-TS-412-145-I 104**

VOLUME **II-B**

SECTION **C**

REV. NO. 01

DATE: 03.09.15

SHEET 11

OF 135

- 10) Valve Body and trim design shall achieve Noise abatement.
- 11) **Separate moisture separator unit** for ensuring dryness of air entering smart positioner units as well as the power cylinder/diaphragm actuator is to be supplied with each control valve(as shown in the hook-up diagram). The moisture separator shall have a minimum efficiency of 99 % viz. should be able to knock out min. 99 % moisture from the air. The make/model shall be subject to approval by Customer after award of contract.
- 12) Control valve accessories shall be fitted on the valve body. Integral pneumatic tubing shall be $\frac{1}{4}$ "OD SS 316, and fittings shall also be of SS 316. Applicable accessories shall be terminated at the junction box (mounted on the body).
- 13) Swagelok or equivalent flare less fittings shall be used for the tubing connections.
- 14) Type of flow action ("under the seat" or "over the seat") will be selected by the bidder. However in cases where downstream side is subjected to vacuum, flow action shall be "flow to close" (over the seat). Specific mention for the same has not been made in the datasheets.
- 15) **Trim material and body material has been specified in the Datasheets-A. Bidder to offer body material & trim material combinations equivalent or better than the material specified in Datasheets-A. Wherever there is deviation from the datasheets, bidder to furnish the documentary proof for confirming superior trim material/ body material selection along with their offer. BHEL/Customer reserves the right to accept/reject any variation to the specification.**
- 16) Trim supplied shall be suitable for quick changing and trim exit velocity shall be limited to avoid cavitation.
- 17) The sizing procedure followed shall be as per latest edition of ANSI/ISA or equivalent standard.
- 18) The End Connections Shall Be Socket Welded For Sizes up to 50 NB And Butt Welded For sizes above 50 NB.
- 19) Stem material for all Control Valves shall be SS 316 STELLITED.
- 20) **The Liquid pressure recovery factor (FL) shall be 0.995 or better for severe flashing/cavitation services.** Bidder to furnish applicable catalogs in support of the same.
eg. Low Load Feed Control Valve
- 21) **The Liquid pressure recovery factor (FL) shall be 0.985 or better for low flashing/cavitation services.** Bidder to furnish applicable catalogs in support of the same.
- 22) Facility to adjust the maximum travel of stem & starting point of travel shall be incorporated.



Technical specification for
Control Valves with Accessories
(Pneumatically Operated)
2 X 660 MW ENNORE STPP

SPEC NO.: **PE-TS-412-145-I 104**

VOLUME **II-B**

SECTION **C**

REV. NO. 01

DATE: 03.09.15

SHEET 12

OF 135

- 23) Bidder to furnish the list of all control valves for which Cv test is to be carried. Cv test shall be carried out for each type of control valve (of same size, Cv, trim characteristics). Cv test shall be witnessed by the Customer and shall be verified by BHEL/Customer.
- 24) Bidder to furnish the list of all control valves for which FL test is to be carried. FL test shall be carried out for each type of control valve. FL test shall be witnessed by the Customer and shall be verified by BHEL/Customer.
- 25) Calculation of Cv, noise level, valve outlet velocity, trim exit velocity, actuator sizing, Data sheet-C in line with Datasheet-A of specification, dimensional drawings / edge preparation details, etc. shall be submitted for BHEL/Customer review and approval, to reach BHEL within 15 days after receipt of PO/LOI.
- 26) Bidder to note that **wherever downstream side of the valve is subjected to the vacuum service, bidder to offer double gland packing, and in that case, flow direction of working fluid shall be over the seat (as to close the valve)**. Separate indication for the same has not been made in the data sheets-A.
- 27) Selection of valves and actuators are bidder's responsibility. Any change in selection of type of valve / sizing / percentage opening, calculations, QP, etc., if desired by BHEL / customer during approval of the documents after award of contract, without major changes in process parameters as per tender specification, shall be carried out by bidder without any commercial implication and time delay.
- 28) Limit switch, position feedback shall be terminated up to JB by 0.5 mm²/PVC/Cu/1.1 KV/FRLS shielded control cables. Solenoid valve shall be terminated by 2.5 mm² size cable.
- 29) SS nameplate for control valve shall include tag no./KKS no./Sl. No./body material /size/press rating/trim material/trim type/action on air failure/diaphragm air pressure at full open and close condition.
- 30) Open to close and close to open time of pneumatic actuator (modulating type) shall be less than 10 sec. Bidder to include volume booster if required to achieve response time less than 10 sec. For ON/OFF type control valve also, the actuator shall have a response time less than 10 sec.
- 31) Specification of electrical actuator given under Section D shall not be considered.
- 32) Hand wheel shall have open/close direction and shall be side mounted.
- 33) Air filter regulator shall be designed for an inlet pressure of 5-8 kg/cm².
- 34) Limit switch shall be designed for 1, 00,000 operations.



Technical specification for
Control Valves with Accessories
(Pneumatically Operated)
2 X 660 MW ENNORE STPP

SPEC NO.: **PE-TS-412-145-I 104**

VOLUME **II-B**

SECTION **C**

REV. NO. 01 DATE: 03.09.15

SHEET 13 OF 135

35) Expander/reducer b/w the main pipe and the valve inlet and outlet shall be in BHEL's scope of supply. However, any expander/reducer coming b/w the valve and low noise pack (as applicable) shall be in bidder's scope of supply.

36) JB shall be 36 ways with FRP body as per enclosed hook-up diagram.

37) Inspection shall be carried out in line with approved drawing/data sheet/QP & specific technical requirements.

38) Third party inspection: Customer and BHEL's nominated agency shall witness the inspection for control valves at the manufacturer's works/ FCRI, PALAKKAD as per the Quality Plan. Bidder to inform 15 days before the date of inspection.

39) In case during erection/commissioning of the control valve, any spares are required which have not been specified in the start-up/commissioning spares list, the same will have to be supplied by the bidder free of cost.

40) The valve sizing shall be suitable for obtaining maximum flow conditions with valve opening at approximately 80% of total stem travel & minimum flow condition not less than 10% of total stem travel. All the valves shall be capable of handling at least 120% of required maximum flow. The stem travel range from minimum flow condition to maximum flow shall not be less than 50% of the total stem travel

41) **SPARES:** The following spares are required to be offered

(A) Mandatory Spares:

The items listed in list of mandatory spares attached at section-D, of this specification, are the essential spares required to be offered by the bidder, and the price for which (Lump sum as well as individual) for each item to be quoted separately under the separate heading. The format for price schedule to be filled-up by the bidder is enclosed in Volume-III. The prices for Mandatory spares indicated by the bidder shall be used for bid evaluation purpose.

Each case/container containing Mandatory spares shall be clearly marked or labelled on the outside with the description of the spares contained in it. When more than one item of spare parts is(are) packed in a single case/carton, a general description of the contents shall be shown outside such case/container, and detailed list enclosed. All Cases, Containers and Packages must be suitably marked and numbered for the purpose of identification.

(B) Recommended Spares:

In addition to the Mandatory spares mentioned, the bidder shall also furnish a List of Recommended spares for 3 years of normal operation of Control valves / Accessories. BHEL/Customer reserves the right to buy any or all of the recommended spares.



Technical specification for
Control Valves with Accessories
(Pneumatically Operated)
2 X 660 MW ENNORE STPP

SPEC NO.: **PE-TS-412-145-I 104**

VOLUME **II-B**

SECTION **C**

REV. NO. 01

DATE: 03.09.15

SHEET 14

OF 135

The prices of these spares will remain valid for a period of minimum 6 months after placement of order.

(C) Start-up & Commissioning Spares:

Start-up and Commissioning spares are those spares, which may be required during the start-up and commissioning of the Control Valves. All start-up spares, which are supplied under this contract, shall be strictly interchangeable with the parts for which they are intended for replacements. The format for price schedule to be filled-up by the bidder is enclosed in Volume-III

The Start-up and commissioning spares indicated by the bidder shall be a part of the main control valves supply. However bidder to indicate prices separately. The list of these spares required is enclosed in section-D of this specification.

- 42) Bidder to indicate the service life expectancy period for the spare parts under normal working conditions. The spares shall be treated and packed for long storage, under climatic conditions prevailing at site. Small items shall be packed in sealed transparent plastic bags with desiccators' packs as necessary.
- 43) In case of multistage valves, pressure drop across each stage shall ensure that the valve does not cavitate in any of the stages.
- 44) Bidder to use epoxy based corrosion resistant paints for painting the valves. Paint of all accessories must comply with this requirement.
- 45) Bidder to furnish a certificate certifying that design of control valve body, bonnet, fittings shall be as per ASTM Standards & tests on Control Valve body shall be as per ANSI B 16.34.
- 46) Bidder to provide diagnostic software for minimum 50 valve tags per unit for remote calibration and accessing diagnostic features of the smart positioner. This software shall be compatible with the latest version of the operating system/Microsoft Windows. It shall be possible to upgrade the installed diagnostic s/w with the latest available version of Microsoft Windows up to 3 years from the date of Part-1(technical bid) opening. No extra cost shall be incurred by BHEL for upgradation of the software.



Technical specification for
Control Valves with Accessories
(Pneumatically Operated)
2 X 660 MW ENNORE STPP

SPEC NO.: **PE-TS-412-145-I 104**

VOLUME **II-B**

SECTION **C**

REV. NO. 01

DATE: 03.09.15

SHEET 15

OF 135

47) SMART POSITIONER

- i) The smart positioner shall accept 4-20 mA signal from the control system as input and provide a compatible signal for driving the pneumatic actuator.
- ii) In addition to the electrical-to-pneumatic signal conversion and positioning functions, it shall also perform detailed diagnostics & make available the actuator/control valve faults via hart interface. The hart signal for the detailed faults shall be superimposed on the 4-20 mA control signal itself. The faults to be covered shall include valve jamming, air supply failure, leakage etc.
- iii) It shall have facility of characterisation of the valve (i.e. equal percentage, quick opening, linear, etc.) in the positioners itself.
- iv) The positioner shall have the facility of detection of control signal failure and making the valve either stayput/open/close as per process requirement upon this condition as stated in the datasheet.
- v) The smart positioner shall have the fail-freeze feature wherever indicated in the datasheet.

48) Documentation:

(A) Along with the bids: following documents for respective projects separately

- a) Signed and stamped compliance certificates in attached format (VOL.-III).
- b) Schedule of prices in attached format (VOL.-III).
- c) Schedule of submission of Drg./Doc, Equip. Manufacture, Inspection and Dispatch.
- d) Inspection schedule
- e) Quality Plan duly signed & stamped.

(B) After the award of contract:

The documentation as listed below for the project

9 sets of the following documents + 5 sets of CDs to be enclosed with the bids for Approval:



Technical specification for
Control Valves with Accessories
(Pneumatically Operated)
2 X 660 MW ENNORE STPP

SPEC NO.: **PE-TS-412-145-I 104**

VOLUME **II-B**

SECTION **C**

REV. NO. 01

DATE: 03.09.15

SHEET 16

OF 135

- a. Assembly (dimensional) drawings.
- b. Valve Edge preparation details.
- c. Data sheet-C completely filled-up..
- d. Hook-up diagram of Control Valve with Actuator & Accessories.
- e. Valve & Actuator assembly dimensional drawings with weights.
- f. Quality Plan duly signed and stamped.
- g. All calculations like CV, Noise Level, Valve Outlet Velocity, Actuator sizing etc.
- h. All relevant catalogues for the models of the valves as well as accessories finalized.
- i. Bar chart to indicate the time schedule for procurement, manufacture, testing and dispatch.

(C) Final documentation:

Copies of documents / drawings to be furnished by the successful bidder shall be as follows:

- a. Category I & IV approved final drawings/datasheets-16 sets with 6 CD-ROMS.
- b. Valve sizing calculations, noise level calculations and outlet velocity calculations - 16 sets with 6 CD - ROMS
- c. Test certificates - 10 sets with 4 CD-ROMS
- d. "As built" drawings - 10 sets with 4 CD-ROMS
- e. Operation & maintenance manuals for Control Valve, Actuator and all accessories - 18 sets with 4 CD-ROMS

Note: Packing instructions:-

- 1) After inspection of control valves assembly. Smart Positioner along with Pressure Gauge shall be disassembled & packed separately.
- 2) Packing of the control valves and Smart Positioner along with Pressure Gauge shall be done in separate wooden boxes/cases in order to avoid damage during transit and also during storage at site in tropical climatic conditions for a period of 18-24 months.
- 3) Packing boxes shall have clear marking "to be stored indoor, away from water & dust".

	Technical specification for Control Valves with Accessories (Pneumatically Operated) 2 X 500MW NEYVELI NEW TPP (NNTPP) (SG-PKG)	SPEC NO.: PE-TS-400-145-I 104	
		VOLUME II B	
		SECTION C	
		REV. NO. 01	DATE 03.09.15
		SHEET Page 08 of 08	

Guidelines for Packing

- ✓ After inspection of control valves assembly. Smart Positioner along with Pressure Gauge shall be disassembled & packed separately.
- ✓ Threaded connection of Smart Positioner & Pressure Gauge shall be shipped with the end caps fitted to avoid any damage.
- ✓ Instructions with sketch for mounting the Smart Positioner & Pressure Gauge shall be sent along with the aforesaid accessories.
- ✓ Packing of the control valves and Smart Positioner along with Pressure Gauge shall be done in separate wooden boxes/cases in order to avoid damage during transit and also during storage at site in tropical climatic conditions for a period of 18-24 months.
- ✓ All valves & smart positioner along with pressure gauges shall be packed properly with quality wooden planks with proper wooden frame support. Moreover the valves are internally covered with polythene sheets to protect from the water and moisture entry.
- ✓ Stronger shock absorbing cover material like expanded Polyurethane which can take any direct impact on it shall be used for packing
- ✓ Proper reaper support to be provided in the packing and Valve assembly to be aligned properly to avoid the damage of accessories during transit due to vibration effect.
- ✓ Marking for Fragile & Condensing environment shall be done on the packing box.



The Following Details are to be marked on the Packing Cases

- ✓ Address of consignee
- ✓ Purchase order no.
- ✓ Description of items or title of packing list
- ✓ Weight
- ✓ Dimension of the Box
- ✓ Marking showing upright position
- ✓ Marking showing sling position
- ✓ Marking showing umbrella
(i.e. for machines/components to be stored under covered storage)

CHAPTER-11**CONTROL VALVES WITH ACTUATORS****11.00.00 CONTROL VALVES, ACTUATORS AND ACCESSORIES****11.01.00 GENERAL REQUIREMENTS**

11.01.01 This section covers the design and construction requirements of Control Valves, their Actuators and Accessories. Except as otherwise specified herein, the Control Valves and accessory equipment furnished under this specification shall be designed, constructed and tested in accordance with the latest applicable requirements of code for Pressure Piping ANSI B31.1, the ASME Boiler and pressure vessel code, Indian Boiler Regulation (IBR) and other standards referenced herein as well as in accordance with all applicable requirements of the "Federal Occupational Safety and Health Standards, USA", or acceptable equal standards.

11.01.02 The design of Control Valves shall comply with relevant codes and standards, account for relevant design criteria viz. environmental conditions, power and air supply, established reliability (reliability target and life expectancy), design of enclosures as specified in Sections earlier.

11.01.03 All Control Valves and accessories furnished under the Section shall be of Owner approved make, fully meeting the qualifying requirements.

11.01.04 Each control valve station shall be provided with pneumatic bypass control valve or Inching type motorised bypass valve as per process requirement and subject to owner approval. In addition each control valve shall also have upstream motorised valve. Downstream motorised valve shall also be provided as per process requirement and as finalized during detailed engineering.

11.02.00 CONTROL VALVE CONSTRUCTION AND SIZING**11.02.01 General**

1. Valve Construction shall be in accordance with the requirements specified herein. (Bidder to also refer NIT drawing # 114-18-0100).
2. The design of all valve bodies shall conform to the requirements of ANSI (USA) for dimensions, material thickness and material specification for their respective pressure classes.
3. The valve sizing shall be suitable for obtaining maximum operating conditions with valve opening at approximately 80% of total travel. Valves shall be open not less than 15 % of full opening for minimum flow condition and shall be capable of handling at least 120% of the required maximum flow at full open condition. Actual pressure drop is indicated in the specification sheets. Permissible pressure drop shall be calculated and



used by the Bidder for sizing calculations. Valve sizing shall be in compliance with the latest edition of ISA Handbook on control valves, ISA standards "ANSI/ISA-75.01.01, Flow Equations for Sizing of Control Valves" with due consideration for the measures to avoid choked flow. Bidder shall ensure that the valve outlet velocity does not exceed 8 meters/second for liquid services, 150 m/second for steam services and 50% of sonic velocity for flashing services by selecting proper body size for the required Cv.

4. a. The Bidder shall provide valves designed to prevent cavitations, wire drawing, flashing on the downstream side of valve and in downstream piping, when operating through full range under the specified conditions.

For cavitating services, valves with anti cavitation trims shall be offered. This shall ensure cavitation prevention by multiple stages of pressure drops. Detailed calculations shall be furnished by bidder to establish cavitations occurrence or otherwise for various process conditions each service wise.

For flashing services such as heater drains, control valve design shall be specially effected to ensure suitability for the adverse high pressure drops and minimise its detrimental effects on control valve parts.

Bidder shall furnish detailed catalogue, calculations, write ups to establish compliance to these stipulations with the selection of each valve. No price implications during engineering stage would be admissible to comply with these stipulations and intents of specification.

- b. The Liquid pressure recovery factor (FL) shall be 0.995 or better for severe flashing/cavitation services.
- c. The Liquid pressure recovery factor (FL) shall be 0.985 or better for low flashing/cavitation services.
5. Each valve shall be designed for tight shut-off against pressure, the valves shall have maximum permissible leakage rate as per ISA RP 39.6 Leakage Class IV (0.01% of rated valve capacity) or specified other wise.

Control Valves for Application such as HP/LP heaters emergency level control, ~~SH spray & RH Spray control~~, Emergency makeup to Hotwell, Deaerator drain to condenser hotwell & ~~heavy oil heating, HFO & LDO and Pressurizing control system~~, condenser normal make up control valve shall have permissible leakage rate as per leakage class V (ANSI/FCI).

~~All SH/RH block valves, shut off valve of LDO & HFO and BFP recirculation valve shall have leakage class MSS-SP-61.~~



6. The valve design shall take into account noise abatement considerations. The design objective will be to limit the generation of valve induced noise to 85 dBA at 1 Meter from the valve surface under actual operating conditions. The noise abatement shall be obtained by valve body and trim design and piping arrangement and not by the use of silencers.
7. The Bidder shall be responsible for proper sizing of the valve and selection of appropriate model and materials of constructions for meeting the operating requirements specified herein and details subsequently furnished during the detailed engineering stage.
8. The valve travel time shall be less than 10 second for non critical services valves.
9. Rangeability should be 50 to 1 (min.) for non critical services valves.
10. Control Valve's Linearity, Hysteresis, Accuracy shall be $\leq \pm 1\%$ and Sensitivity shall be $\leq \pm 0.5\%$.

Bidder shall furnish the Control Valve data sheets and sizing calculations with the proposal which will be subjected to owner approval during detailed engineering. The bidder shall furnish all valves as per Owner approved data sheets and drawings.

11.02.02 Valve Construction

1. All valves shall be of globe body design and straightway pattern. Straightway pattern valves shall be either single or double ported as specified. Double ported and single ported valves shall have high lift cage guided plugs, unless otherwise specified.
2. Where specified, valves with cage guided plugs and quick change trim shall be supplied. The quick change trim shall consist of a cage and seat ring clamped in the valve body by the valve bonnet and sealed with a spiral wound stainless steel with Graphite filler. The trim shall be removable through the top after bonnet removal without any cutting or welding of the valve. Where applicable, plugs shall be designed to include pressure balancing for cage guided valves.
3. Direct acting and self-contained pilot type valves may have low lift plugs.
4. Cast iron valves are not acceptable.
5. Bonnet joints for all control valves shall be of the flanged and bolted type or other construction acceptable to the Owner. Bonnet joints shall be designed for easy disassembly and for assurance of correct valve stem alignment. Bonnet joints of the internal threaded or union type will not be acceptable.
6. Plugs shall be of one-piece construction either cast, forged, or machined from solid bar stock. Plugs shall be screwed and pinned to valve stems or shall be integral with the valve stems.



7. When Teflon packing is used, the lower valve stem which passes through the stuffing box shall be polished to at least 2×10^{-4} millimeters r.m.s.
8. Valves gland packing shall normally be Teflon on liquid and gas services up to 100 kg/cm^2 and 230 Deg.C Teflon and PTFE for higher temperatures.
9. All valves shall be arranged so that the plugs may be removed from the valve bodies from the bonnet side.
10. Each valve shall have an arrow permanently fixed on the valve body to indicate the correct direction of flow.
11. Each valve shall have a stainless steel name plate permanently fastened to the yoke which shall be visible when the valve is in service. The name plate shall include
 - a. Tag No. and Valve Serial No.
 - b. Body material, size and pressure rating
 - c. Trim material, size characteristics
 - d. Action on air failure
 - e. Spring range
 - f. Stem travel
 - g. Valve action, etc.

11.02.03

Valve Materials

1. Valve material shall be as specified in Supplier's approved Control Valve Specification sheets. The following table defines abbreviations used for valve materials:

S.No.	Abbreviations	Description
a	BR	Bronze ASTM B 61
b	CS	Carbon Steel Forged - ASTM A 105 Cast - ASTM A 216 Grade WCC
c	1- ¼ CR	1-1/4 % Chromium Alloy Steel Forged – ASTM A 182 Grade F11 Cast – ASTM A 217 Grade WC6
d	2- ¼ CR	2-1/4 % Chromium Alloy Steel Forged – ASTM A 182 Grade F22 Cast – ASTM A 217 Grade WC9
e	5 CR	5% Chromium Alloy Steel Forged – ASTM A 182 Grade



		F5 Cast – ASTM A 217 Grade C5
f.	SS	Stainless Steel AISI Type 316 ASTMA 351 Grade CF8M

2. Body material shall be selected by the Bidder to be compatible with the nature of the fluid, service conditions, and piping material to which it is welded and shall be subjected to Owner approval. In general, cast or forged carbon steel bodies shall be provided for non-corrosive process applications up to 275 Deg.C. Alloy Steel castings shall be provided when the media is non-corrosive and the temperature exceeds 275 Deg.C and is within 550 Deg.C. Stainless Steel of suitable grade shall be provided when media is corrosive and the temperature is below 300 Deg.C.

Sr. No.	Service	Body Material
1.	Non Corrosive, Non Flashing, and non cavitations service for process temp. up to 275 deg. C like Aux. steam flow to Deaerator, Cond. Flow to deaerator, Fuel Oil, Atomising steam service etc.	Cast Carbon Steel ASTM A216 Gr. WCB/WCC
2.	Non Corrosive, Non Flashing, and non cavitations service for process temp. above 275 deg. C. and up to 550 deg. C. and for CRH flow to Deaerator.	Cast Alloy Steel ASTM A217 Gr. WC9
3.	Severe Flashing/ cavitations service like Feed Control Valve, Spray Control valves, LP/HP heater emergency level control valve, HP BP spray control valve, Deaerator Overflow control valve etc.	Cast Alloy Steel ASTM A217 Gr. WC9
4.	Low Flashing/ cavitations service like LP/HP heater normal level control & Condensate/feed water below 275 deg. C.	Cast Alloy Steel ASTM A217 Gr. WC6
5.	DM Water Application (Condenser Hotwell normal & Emergency make up etc.)	Cast type 316 Stainless Steel ASTM A351 Gr. CF8M

3. Unless otherwise specified, all control valves shall have stems, guide bushings, plugs, seat rings, stem lock pins, stuffing box parts, and other trim, all made of stainless steel. Valve guide posts and bushings shall be stellite faced for valves where specified. Stellite faced guide posts and bushings shall be differential hardened. For applications involving high pressure drop as also for flashing and cavitation services, trim material shall be properly chosen to ensure required degree of hard facing (such as 17-4 PH SS) so as to avoid erosion.

Sr. No.	Service	Trim Material
1.	Non Corrosive, Non Flashing, and non cavitations service for process temp. up to 275 deg. C. like Aux. steam flow to Deaerator, Cond. Flow to deaerator, Fuel Oil, Atomising steam service etc.	SS316 Stellite
2.	Non Corrosive, Non Flashing, and non cavitations service for process temp. above 275 deg. C. and up	SS316 Stellite



	to 550 deg. C. and for CRH flow to Deaerator.	
3.	Severe Flashing/ cavitations service like Feed Control Valve, Spray Control valves, LP/HP heater emergency level control valve, HP BP spray control valve, Deaerator Overflow control valve etc.	440 SS
4.	Low Flashing/ cavitations service like LP/HP heater normal level control & Condensate/feed water below 275 deg. C.	17-4 PH SS
5.	DM Water Application (Condenser Hotwell normal & Emergency make up etc.)	17-4 PH SS

4. Where stellite facing is not specified, hardened stainless steel shall be furnished for all surfaces subject to wear.
5. Manufacturer recommended materials for cage guided valves may be substituted for materials specified provided they satisfy the specified service conditions. Also where substitutions are made, the manufacturer shall guarantee performance of recommended materials to be equal to or better than the specified materials for conditions specified.

Bidder may offer valve with body and trim material better than the specified material and in such case, bidder shall furnish the comparisons of properties including cavitations resistance, corrosion resistance, temp. resistance, erosion resistance, hardness etc. of the offered material vis a vis specified material for owner approval.

11.02.04 **End Preparation**

1. Valve body ends shall be butt-welded type.
2. Flanged ends shall be of a pressure class equal or greater in pressure-temperature rating to the body design pressure and temperature indicated on the control valve. Unless otherwise specified, steel flanges shall be raised face type. Flanged ends for valves shall be in accordance with ANSI B 16.5.
3. Welded end for control valves where specified shall be socket-weld per ANSI B 16.11 for control valves of sizes 50 mm (2") and below and Butt welded connections per ANSI B16.25 for control valves 65 mm (2-1/2") and above. The end preparation for butt welded control valves shall be matched to the corresponding details for the piping on which the valve is installed.
4. All end preparations shall be as per Owners requirements indicated during Contract stage.

11.02.05 **Miscellaneous Parts**

1. Extension bonnets shall be used on all valves when the maximum temperature of the flowing fluid is greater than 275 deg. C or when specifically required in the control valve.
2. Stem travel indicators shall be provided on all valves.



11.03.00 VALVE OPERATIONS

- 11.03.01 All control valves shall be furnished with pneumatic spring opposed diaphragm, spring less diaphragm, or piston operators as specified herein.
- 11.03.02 The bidder shall be responsible for proper selection and sizing of valve operators in accordance with the pressure drop and maximum shut-off pressures.
- 11.03.03 Valve operators and stems shall be adequate to handle the unbalanced forces occurring under the specified flow conditions or the maximum differential pressure specified. An adequate allowance of stem force, at least 0.15 kg/sq. cm per linear millimeter of seating surface, shall be provided in the selection of the actuator to assure tight seating unless otherwise specified. The actuators shall be designed to produce the required stem force with supply air pressure of 3.5 kg/sq. cm maximum unless otherwise specified.
- 11.03.04 Diaphragms shall be moulded synthetic rubber and diaphragm housing shall be of pressed steel construction. Diaphragms shall not be fabricated of natural rubber.
- 11.03.05 Piston operators shall use cast pistons and cylinders with O-ring seals. Actuators shall be supplied with name plates which indicate the diaphragm air pressure at full open and full closed positions. for single seated valves the pressures shall be listed for maximum differential and for zero differential across the valve.
- 11.03.06 Pistons and cylinders shall be cast aluminum. Piston rod and extension shall be chrome plated stainless steel. Cylinder seal bushings shall be brass and seal rings shall be nitrile. Yoke shall be cast iron.
- 11.03.07 Valve operators shall be capable of operating at 60 °C continuously.

11.04.00 CONTROL VALVE ACCESSORIES & DEVICES

The following accessory equipment shall be provided for control valves:

- 11.04.01 **Air Locks:** Air locks shall be designed to shut off the diaphragm loading air line if the supply air pressure to the associated pilot or Positioner fails. Air locks shall be of the automatic reset type and shall be furnished with alarms.
- 11.04.02 **Hand Wheels:** Hand Wheels shall be provided. Hand wheels shall be side mounted unless specified to be top mounted. However the mounting shall be as decided during engineering to offer maximum accessibility.
- 11.04.03 **Limit Switches:** Each control Valves shall be provided with limit switches for monitoring of end position in DDCMIS/DCS/PLC. Switches shall have not less than two normally open and two normally closed contacts in both open and close directions. Electrical rating of the limit switch contacts shall be 240V AC, 5 amp or 220V DC, 0.5 amp. Limit switches should be National Acme Co., or Honeywell micro switch type or Owner approved equal. The enclosures of the limit switches



shall be as per NEMA-4 Standard. Limit switches shall be constructed to withstand the temperatures encountered in the actual service. Explosion proof construction shall be furnished where required by applicable code or these specifications. Limit switches shall be factory mounted on the valves with provisions for adjusting the mounting. The Bidder shall stroke the valves to check limit switch operation prior to shipment.

Limit/micro switches can be offered as an integral part of Smart valve positioner.

11.04.04 **Smart Valve Positioner:** Control valve actuators for modulating and throttling services shall be provided with HART protocol based smart electro pneumatic valve Positioner to ensure accuracy & repeatability of response. The valve Positioner shall be designed suitable for vibration and service conditions of a steam electric power station.

The Positioner shall have the following features:

- a) Shall provide a pneumatic output signal of range 0.2 to 1.0 kg/cm² or as desired for the actuator.
- b) Shall have integral type position transmitter, input & output gauges, local keypad, display, 4-20 mA input and 4-20 mA output for position indication in DDCMIS/CCR/PLC.
- c) Shall be suitable for direct mounting on control valve assembly both for rotary & linear valves.
- d) Shall be capable of functioning under hot, humid & vibrating conditions.
- e) Shall have dust tight, corrosion resistant & weather proof IP 65 metal casing.
- f) Shall be operated at signal range of 4-20 mA for full travel of the valve. Split range operation in few case may be required. This facility shall also be available in positioner.
- g) Shall have in built mechanical position indicator.
- h) Shall have fail safe & fail freeze function as per loop process requirement.
- i) Shall have in built auto tune facility.

11.04.05 **Solenoid Valves:** Solenoid Valve will be provided for the following

- i. **ON / OFF Duty type Control Valve**
- ii. For over-riding the controller signal with Modulating type Control valves.
- iii. For control valve stay put position requirement on controller signal failure with Modulating type Control valves.
- iv. For construction and detailed specification of Solenoid valve, clause no. 3.03.32 shall be referred by bidder.

11.04.06 **Diffusers :** Diffusers shall be provided as per service application requirements. The diffuser shall be designed to reduce the pressure drop across the control valve below the critical value and reduce the sound pressure level. Details of the diffusers shall be submitted.



- 11.04.07 **External Volume Chambers:** External volume chambers with adjustable bleed valves shall be provided for Control Valve. Volume chambers shall be furnished, mounted on the control valve yoke assembly.
- 11.04.08 **Position Transmitters:** Position transmitters shall be provided for control valves as a part of smart positioner. The signal shall be 4-20 mA DC range, 24 V DC. For non smart positioners applications and power cylinders, contact less position transmitter shall be provided by bidder.
- 11.04.09 **Tubing and Air Sets:** All pneumatic tubing required to interconnect devices assembled together shall be furnished complete with each control valve. The tubing shall be fully annealed soft temper copper tubing conforming to ASTM B68 to B75 (USA). Swage lock flare less tubing fittings shall be used for tubing connections (Swage lock or approved equal).
- Each device requiring an air supply shall be equipped with a combination filter-regulator. Devices mounted together on a valve yoke may be served by a single regulator, provided the supply pressure is satisfactory and the regulator capacity is not exceeded. Filter-regulators shall be mounted on the device served.
- Filter-regulators shall be suitable for a 10 kg/sq. cm maximum inlet pressure. Filter-regulators shall have built-in housing blow down valves and a 2 inch pressure gauge. The filter shall be of size not more than 5 microns and shall be made of sintered bronze.
- ~~11.04.10 **Pressure Switch**~~
- ~~Pressure switch suitable for the above the pneumatic system shall be provided. The contact rating shall be 2 A for 240 AC, .2 A, 220 VDC 2 SPDT Contact. Enclosure IP 65.~~
- 11.04.11 **I/P Converter**
- For non smart positioners applications and power cylinders i/p converters shall be required and owner approval shall be obtained for the use of i/p converter for such applications.
- ~~Electro-pneumatic, outdoor type, field mounted Linear. 4-20 MA DC input and 0.2 – 1.0 kg/Cm² output. Die cast aluminum casing with IP65 or equivalent enclosure class. Accuracy of $\pm 0.5\%$ of span or better and repeatability of $\pm 0.5\%$ of span or better will be provided. Easily accessible span and zero adjustment will be provided I/P converter shall be provided with all accessories and erection hardware. The I to P converters shall retain the pneumatic signal (last value) even in failure of control signal and shall have self volume boosters.~~
- 11.04.12 **Separate moisture separator unit** for ensuring dryness of air entering I/P as well as the power cylinder is to be supplied **with each control valve and control damper.**
- 11.05.00 **FOR FOLLOWING CRITICAL APPLICATION SPECIAL CONTROL VALVES ARE REQUIRED.:**



1. ~~HP & LP Bypass Valves and Control System~~
2. ~~BFP – Minimum Re-circulation Valve~~
3. Feed Water Control Valve
4. ~~SH & RH spray Control Valves~~
5. ~~APRDS System~~
6. ~~Soot Blower control valve~~

11.05.01 **General Requirements for Critical Application Control Valves for -**

- i) The valve accessories shall include hand wheels, limit switches, smart valve positioner (4-20mA DC type), electro pneumatic converter, Air lock relay, Solenoid valve and all other items required for the completeness and the accessories shall be explosion proof type as per hazardous area classification wherever applicable.
- ii) Control valves shall be furnished with IBR certification wherever required.
 1. **Noise:** The maximum allowable noise level shall be 85 dba or less at 1 m. distance from the downstream bare pipe surface. The specified noise level shall be attained without the use of orifices, mufflers, diffusers. No credit for thermal or acoustical insulations shall be taken.
 2. **Valve Trim:** Valve shall have quick change type trim utilizing top entry. No components shall be screwed or welded into the body. The valve shall have equal pressure distribution around the plug to avoid chattering / vibration.

Trim of severe/critical service valve shall be of multi stage & multi path design with sufficient no. of discrete pressure drop stage to eliminate the chance of erosion, cavitations, noise, vibration through out the control range of valve.
 3. **Leakage Class:** The valve shall have minimum class-V leakage for all steam applications including APRDS, HP/LP bypass spray control valves & Low Load feed water control valve.

In case of minimum boiler feed pump re-circulation applications, RH/SH spray control valves and HP/LP Bypass control valve application, the leakage class should be MSS-SP 61 (block valve leakage).
 4. **Actuator:** Actuator type should be pneumatic double acting piston/Hydraulic.

11.06.00 **Specific Requirements / Specifications for Different Valves:**

11. 06.01 Design Criteria for selection of Feed Water Control Valve :

The valve trim should be multi – stage, multi – path, multi – disk design having sufficient no.'s of discrete pressure reductions (turns / stages) to ensure elimination



of vibration, cavitations, erosion and noise effects. Pressure reduction / drop achieved by valve designs incorporating single or multistage orificed cage, diffusers are not acceptable. Bidder should work out no. of pressure drop turns in the trim of the valve and should provide calculations of trim exit velocity. Seat ring and trim fitment should not have any part screwed or welded. It should be easily replaceable type.

Flow vs. valve opening characteristic: The trim is to be so designed that the min. flow indicated in the bid specifications of the valve is achieved with min. lift of 20mm of valve plug from "Close" position. Subsequent characteristic should be "equal percentage" i.e. corresponding to the parabolic characteristics. Characterizing the cam of the positioner to minimise the required flow char is not acceptable.

Rangeability should be 50 to 1 (min.). Each pressure - reducing element should have a uniform pressure distribution around the plug to avoid mechanical vibrations (pressure equalizing rings / grooves). To prevent flow induced vibrations and the line trash damage to seat, the flow direction should be over the plug. During throttle opening of the control valve, flow should be diverted away from the body seat.

Required leakage should be better than ANSI – B - 16 – 104 Class – V with metal to metal seating. Soft seat is not acceptable. Requisite calculations in support of above leakage class to be submitted with the offer. The bidder should indicate how this will be achieved in their valves and actuators. Actuators should be pneumatic double acting piston type. Diaphragm type actuators are not acceptable.

The seating force on the valve seats to achieve the required leakage class (better than ANSI – B - 16 – 104 Class – V) should be about 180 kg / cm on seat ring. PI. indicates the closing force on the seat in Kgf / cm of seat circumference applied for actuator. Trim exit velocity should be less than 22.5 M / sec. Calculation sheet should be attached demonstrating satisfactory compliance of this requirement.

Noise level at 1 meter distance from the valve should be less than 85 dB without insulation, orifices, silencers, mufflers etc. Calculation sheet to be attached for each valve offered. Critical cavitation index (Kc) for all control valves should be 1 (one). This is specific requirement to avoid even remote possibility of cavitation damage to valve internals. Material of the valve internals should be as under:

Guide	:	400 series SS
Plug / Seat ring	:	400 series SS
Stem	:	17 – 4 PH

~~11.06.02 Control Valve Specifications For Turbine By Pass System~~

~~11.06.02.01 **Turbine Bypass Control System:** Standalone turbine bypass control system for each unit shall be provided. The control system shall include operator selectable manual or automatic modes with bump less transfer between modes. The turbine bypass system shall be included in the plant automation sequence for unit start-up and bypass operation.~~



3.03.42

Junction Boxes

- | | | | |
|-------|---|---|--|
| v. | Type | : | Flame proof/weather proof |
| vi. | Enclosure | : | IP-65/Explosion/Flame Proof as per area classification. |
| vii. | Material | : | FRP with protective Coating |
| viii. | Cable entry | : | Bottom or Side |
| ix. | Cable glands | : | Double compression type – Nickel plated brass with PVC hoods. |
| x. | Mounting | : | Indoor/Outdoor |
| xi. | No. of terminals | : | As required with standardization with 20% spare of each size & type. |
| xii. | Terminals | : | Phoenix/Wago (screw less cage clamp type spring loaded) |
| xiii. | Grounding | : | Two terminals for body and shield ground |
| xiv. | Door | : | Hinged, lockable type. |
| xi. | Suitable mounting clamps and other accessories shall be in scope of bidder. | | |
| xii | The brackets, bolts, nuts, screws, glands, lugs required for erection shall be of brass, included in bidder scope of supply. High voltage & insulation resistance test shall also be conducted. | | |
| Xiii | M6 Ni plated Brass earthing stud shall be provided (external 2 nos. internal 1 no.) | | |
| xiv | Gasket (Normal)- Neoprene thickness 6.0 mm | | |



injected spray water. Water shall not be injected through the stem due to leakage potential past internal seals and to eliminate possibility of stem cracking due to thermal shocks. Water spray should be fully atomised within a meter of valve outlet to ensure uniform reheater temperature and to allow pipe bends directly after the valve and to allow carbon steel piping downstream of the valve.

Packing shall be compressed by means of a bolted flange design, screwed gland type packing retainers shall not be provided. Bolted bonnets are preferred. If pressure seal bonnets are used, seal areas shall be inlaid with corrosion resistant materials to minimise leakage potential. Valve shall be mounted with actuator in vertical direction for ease of maintenance.

11.06.02.04 LP-Bypass Steam Conditioning Valves: The steam conditioning valves shall be angle flow to close type combination pressure reduction and desuperheating control valves. Multi-hole plugs shall not be used due to potential for contamination sticking between plug and seat. A combination of cage guiding and top guiding for plugs shall be provided to eliminate possibility of vibration. Conical diffusers as required shall be of wrought construction provided with higher mechanical strength and to allow for optimum velocity distribution downstream of the diffusers. The diffusers shall be removable through bonnet to allow for inspection and maintenance. No components may be screwed or welded inside the valve body for easy maintenance. Packing shall be compressed by means of a bolted flange design. Screwed gland type packing retainers shall not be provided. Bolted bonnets are preferred. If pressure seal bonnets are used, seal areas shall be inlaid with corrosion resistant materials to minimise leakage potential. The valve body shall be 2-1/4 percent chromium alloy steel with martensitic chromium steel internal trim steel. Valve packing shall be pure graphite.

The spray water injection shall be downstream of the seat but part of the valve. Spring-loaded nozzles shall be used to ensure good atomisation and good penetration of the spray water into the steam. The outlet cage shall be shaped that it guides the steam towards the injected water for good mixing of the steam and the spray water. Spray through stem shall not be provided due to leakage potential past internal seals and to eliminate possibility of stem cracking due to thermal shocks. No downstream pipe liner shall be required and thus carbon steel materials can be used on the downstream of the valve. The steam conditioning valve shall have a quick closing emergency function with a completely independent solenoid valve on the actuator. The quick closing shall still be equipped with a separate accumulator for operation independent from the Hydraulic Supply unit. The valves shall be provided with body taps upstream of the valve seat; and piping, valves and orifices as required for providing a pre-warming flow path.

11.06.02.05 Spray Water Control Valves: Trim exit velocity of liquid shall not exceed 30 m/s to prevent flow induced vibration. To protect the valve internals from foreign particles such as weld slag, flow direction shall be "flow to close" (over the plug) configuration for liquid applications. Valve shall have quick change type trim utilising top entry. No components shall be screwed or welded into the body. The valve shall have equal pressure distribution around the plug to avoid chattering / vibration. The leakage class shall be minimum class-V.



a) HP-Bypass Spray:

The trim for pressure reducing stages shall be of multistage type to ensure elimination of erosion, cavitation, noise and vibration throughout the stroke length of the valve. Bidder shall indicate the number of pressure erection stages in the proposed valve by furnishing calculations demonstrating compliance to the trim exit velocity.

b) LP-Bypass Spray:

The spray water control valve shall be cage guided valves sized as required to provide spray water to the steam conditioning valves. The spray water valve shall be carbon steel with stainless steel internal trim. Velocity of water at trim exit shall not exceed 30 ms/ Valves shall be free of cavitation.

11.06.02.06 Valve Operators: The steam conditioning valves and the spray water control valves shall be provided with double acting electro-hydraulic piston operators. All valves shall be quick opening and closing and shall be modulating valves with positioners designed to receive a 4 to 20 milli-ampere signal. The LP-Bypass steam conditioning valve shall have a quick closing emergency stop function with a completely independent solenoid valve on the actuator and a separate accumulator for operation independent from the hydraulic supply unit. The operator time shall be as required to protect the condenser from overpressure and temperature.

A single hydraulic power unit shall be provided and sized to operate and control all the steam conditioning valves, and spray water control valves for each unit. The hydraulic unit shall be complete with 2x100% capacity motor driven pumps, valves, piping instrumentation, tubing, reservoir and accumulator(s), control cabinet with accessories all mounted on a common base. The motors shall be connected two (2) different power supplies. The hydraulic system shall have online filtration arrangement to keep hydraulic oil clean. The system shall have automatic temperature control device mounted on the tank to maintain hydraulic oil temperature below 60 deg. C.

11.06.03 **Specification of BFP Recirculation Control Valve :**

Trim should be of multistage, multipath, multiturn type having sufficient number of discrete pressure drop stages to ensure elimination of erosion, cavitation, noise and vibration throughout the stroke length of the valve.

Supplier shall identify the number of pressure drop stages in opposed valve and shall also provide calculations demonstrating compliance to the trim exit velocity.

The trim exit velocity for liquid (water) shall not exceed 22.5M/sec. The supplier shall provide calculations demonstrating satisfactory compliance to the above criteria.

For liquid service, the flow direction shall be 'OVER THE PLUG" i.e. FLOW TO CLOSE to prevent flow induced vibration and to protect damage on the valve internals from foreign particles such as weld slag etc.



The flow path shall be radial and each disk element should be capable of reducing the entire pressure independency. No orifice, No mufflers / diffusers are permitted.

The maximum allowable noise level shall be less than 85 dba at 1 meter distance on bare pipe surface No orifice Plate downstream of the control valve should be used for pressure reduction.

The specified noise level shall be achieved without the use of orifices, mufflers or diffusers. No credit for thermal or acoustical insulations shall be given.

No orifice Plate downstream of the control valve should be used for pressure reduction

The supplier shall provide calculations demonstrating compliance to the noise requirement.

The valve shall have minimum **MSS-SP-61 Leakage class** in metal to metal seating with minimum seating force of 180kgf per linear mm of seat ring circumference. Soft seat is not acceptable.

Vendor to provide calculations to indicate close force on the seat applied by actuator.

Vendor shall confirm that the proposed valve shall maintain tight shutoff leakage class even after 3 years of field service.

The valve shall have quick change type trim utilizing top entry. No components shall be screwed or welded into the body.

The valve shall have equal have pressure distribution around the plug to avoid chattering/vibration.

Pneumatic double acting piston actuator shall be preferred.

11.06.04

SH/RH Spray Control Valves (Technical Requirement) :

- a) Seat ring and trim fitment should not have any part screwed or welded. It should be easily replaceable type.
- b) The valve trim should be multi – stage, multi – path design having sufficient numbers of discrete pressure reductions (turns/ stages) to ensure elimination of vibration, cavitation, erosion and noise effects.

Pressure reduction/ drop achieved by valve designs incorporating single or multistage orificed cage, diffusers are not acceptable because of our bad experience with this type of design.

Bidder should work out number of pressure drop turns in the trim of the valve and should provide calculations of trim exit velocity.

- c) Flow Vs. Valve opening characteristic:



The trim is to be so designed that the minimum flow indicated in the bid specifications of the valve is achieved with minimum lift of 8 mm of valve plug from "close" position. Subsequent characteristic should be "EQUAL PERCENTAGE" i.e. corresponding to the parabolic characteristics. Characterizing the cam of the positioner to mimic the required flow characteristics is not acceptable.

- d) Rangeability should be 30 to 1 (minimum) for valves up to 2", 50:1 for valves from 2" to 4" and for bigger valves it should be minimum 100:1. Valve should be able to throttle even below 5% opening without trim erosion.
- e) One single valve should handle zero to 100 percent boiler feed water flow requirements. The valve should be designed for high range ability and total flow characterization from low flow to the maximum flow required.
- f) Each pressure reducing element should have a uniform pressure distribution around the plug to avoid mechanical vibrations (pressure equalizing rings / grooves).
- g) To prevent flow induced vibrations and the line trash damage to seat, the flow direction should be over the plug (for water) and under the plug for steam.
- h) During throttle opening of the control valve, flow should be diverted away from the body seat.
- i) Required leakage of MSS-SP-61 better than ANSI-B-16-104 Class-V equivalent class is achieved with metal seat. Soft seat is not acceptable. Requisite calculations in support of above leakage class to be submitted with the offer.
- j) Leakage class for these control valves required is MSS-SP-61 better than ANSI-B16-104 Class-V or equivalent as the control valves are to work as block valves when in 'CLOSE' condition. The bidder should indicate how this will be achieved in their valves and actuators. Actuators should be pneumatic double acting piston type. Diaphragm type actuators are not acceptable.

The seating force on the valve seats to achieve the leakage class of MSS-SP-61 better than ANSI-B-16-104 class-V or equivalent should be about 180kg/cm on seat ring circumference. Bidder to indicate the closing force on the seat in Kg/mm of seat circumference applied for actuator.

- k) Trim exit velocity in both minimum and maximum flow conditions should be less than 30M/sec. in case of water and 22.5M/sec in case of flashing water conditions. Calculation sheet should be attached demonstrating satisfactory compliance of this requirement.
- l) Noise level at 1 meter distance from the valve should be less than 85dB without insulation. Orifices, silencers mufflers etc. Calculation sheet to be attached for each valve offered.



- m) Critical cavitations index(K_c) for all control valves should be 1(one). This is specific requirement to avoid even remote possibility of cavitational damage to valve internals.

11.06.05

SPECIFICATION FOR APRDS System:**Brief System Description**

Auxiliary steam system is to be designed to provide steam for turbine auxiliaries, Boiler auxiliaries and fuel oil heating system during start-up, low loads and normal running of units.

The system comprises of one auxiliary steam stations capable of meeting 'High capacity' and 'Low capacity requirements' by a single system to meet auxiliary steam requirements during unit start-up, Low loads and for fuel oil system and during normal running. Spray water required for desuperheating will be tapped off from boiler feed pump discharge.

The above stations will reduce the pressure and temperature of the steam tapped off from main steam line. A suitable desuperheater should be considered for reducing the temperature.

Equipment To Be Provided by Bidder:

Combined high capacity and low capacity Auxiliary PRDS comprising of:

a) Control Valves and accessories:

- a) Pressure reducing valve: Having multiturn, multistage, multipath radial trim valve as per specification.
- b) Spray control station: Dedicated to Desuper-heater. The spray water control station should have multiturn, multistage, and flow trim & the same should be a combination of pressure and temperature control valve and a high rangeability desuperheater.

Each control valve shall be supplied with the accessories as specified in the approved data sheets.

Desuperheater:

1. Direct mixing type desuperheater :

The desuperheater shall be completed with spray nozzle along with necessary attachments.

Spares, Consumables and Special Tools and Tackles:

Commissioning spares and consumables:

The bidder shall supply spares and consumables for all the above valves and desuperheaters required during start-up. A list of all spares and consumables to be supplied shall be submitted along with the bid.

Specific Technical Requirements for Control Valves, Actuators and Accessories:

Seat ring and trim fitment should not have any part screwed or welded. It should be easily replacable type.

The valve trim should be multistage, multipath design having sufficient numbers of discrete pressure reductions (turns/stages) to ensure elimination of vibration, cavitations, erosion and noise effects.

Pressure reduction/drop achieved by valve designs incorporating single or multistage orificed cage, diffusers are not acceptable.

Bidder should work out number of pressure drop turns in the trim of the valve and should provide calculations of trim exit velocity.

Flow Vs. valve opening characteristics: the trim is to be so designed that the minimum flow indicated in the bid specifications of the valve is achieved with minimum lift of 8mm. of valve plug from 'close' position. Subsequent characteristics should be 'Equal Percentage' i.e. corresponding to the parabolic characteristics. Characterising the cam of the positioner to mimic the required flow characteristics is not acceptable.

Rangeability should be 50 to 1(minimum). Valve should be able to throttle even below 5% opening without trim erosion.

Each pressure reducing element should have a uniform pressure distribution around the plug to avoid mechanical vibrations(pressure equalizing rings/ grooves).

To prevent flow induced vibrations and the line trace damage to seat, the flow direction should be over the plug for water and under the plug for steam.

During throttle opening of the control valve, flow should be diverted away from the body seat.

The valves shall have minimum ANSI B-16-104 class-V leakage class in metal to metal seating for all applications with minimum seating force of 125kgf per linear mm of seat ring circumference. Soft seat is not acceptable. Vendor shall confirm that the proposed valve shall maintain tight shutoff leakage class even after 3 years of field service.

The bidder should indicate how this will be achieved in their valves and actuators. Actuators should be pneumatic double acting piston type. Diaphragm type actuators are not acceptable.



Bidder to indicate the closing force on the seat in kgf/mm of seat circumference applied for actuator.

Trim exit velocity in both minimum and maximum flow conditions should be less than 30M/Sec. in case of water and 22.5M/sec in case of flashing water conditions. Calculation sheet should be attached demonstrating satisfactory compliance of this requirement.

Noise level at 1 meter distance from the valve should be less than 85dB without insulation, Orifices, silencers mufflers etc. Calculation sheet to be attached for each valve offered.

Critical cavitations index (Kc) for all control valves should be 1 (one). This is specific requirement to avoid even remote possibility of cavitational damage to valve internals.

To avoid problems associated with the piston rings provided in valves of balanced design, unbalanced design for port size upto 25mm. is required. Bidder to indicate the compliance clearly.

Material of the valve internals should be as under:

Guide	:	Inconel 718
Plug/stem	:	Inconel 718
Seat ring	:	SS 316 stellited

Valve actuators:

- i) Piston actuators shall be used for all valves.
- ii) Valve actuators shall be capable of operating at 70 Degree C ambient continuously.
- iii) Castings shall be of the type to suite individual area environments.
- iv) All fix connection size shall be ¼" NPT (Female)
- v) Bidder shall guarantee that the size of the actuator is adequate to meet the operating thrust requirement for the control valve under extreme condition. Bidder shall indicate the stroking time of the valve assemblies with positioner.

Accessories:

Control valve actuators shall be equipped with air supply filter regulator, gauges and valve positioners alongwith boosters for typical applications wherever required, local poison indicator with scale and pointer, position transmitter, limit switch and hand wheel, air lock relay, solenoid valve etc.

Performance:

All control valves shall confirm to MSS-SP-61 leakage class.

11.06.06

SPECIFICATION FOR SOOT BLOWER VALVES:



Trim should be of multistage, multipath, multiturn type having **sufficient number of discrete pressure drop stages** to ensure elimination of erosion, cavitation, noise and vibration throughout the stroke length of the valve. Supplier shall **identify the number of pressure drop stages in proposed valve** and shall also provide calculations demonstrating compliance to the trim exit velocity.

The trim exit velocity for liquid (water) shall not exceed 23M/sec. The velocity head in case of steam / gas services shall be less than 480 Kpa (70 Psia). The supplier shall provide calculations demonstrating satisfactory compliance to the above criteria.

To maximize noise attenuation benefits and to allow for constant fluid expansion, flow direction shall be **'UNDER THE PLUG', i.e. FLOW TO OPEN.**

The flow path shall be radial and each disk element should be capable of reducing the entire pressure independently. No orifice, No mufflers / diffusers are permitted.

The maximum allowable noise level shall be less than 85 dba at 1 meter distance on bare pipe surface. **No orifice Plate downstream of the control valve should be used for pressure reduction.**

The specified noise level shall be achieved without the use of orifices, mufflers or diffusers. **No credit for thermal or acoustical insulations. The supplier shall provide calculations demonstrating compliance to the above noise requirement.**

The valve shall have minimum Ansi B-16-104 class-V leakage class in metal to metal seating for all applications with minimum seating force of 125kgf per linear mm of seat ring circumference. Soft seat is not acceptable. Vendor shall confirm that the proposed valve shall maintain tight shutoff leakage class even after 3 years of field service.

The valve shall have quick change type trim utilizing top entry. No components shall be screwed or welded into the body.

The valve shall have equal pressure distribution around the plug to avoid chattering/vibration.

The valve should have high rangeability to meet low flow and high flow requirements satisfactorily with high% show at low flow condition

Pneumatic double acting piston actuator shall be preferred.

11.07.00 **TESTING AND COMMISSIONING:**

11. 07.01 All valves shall be tested in accordance with the quality assurance programme agreed between the owner and the bidder as specified in chapter 14 which shall meet the requirements of IBR and other applicable codes mentioned in chapter 1 clause-1.09.00. The tests shall include but not be limited to the following.



Valves for high pressure high temperature applications shall be subjected to 100% radiography examination test. Results shall be owner approved prior to dispatch. All castings and forging shall be visually inspected. The casting shall be radio graphically examined. Ultrasonic examination, liquid penetration examination, magnetic particle examination etc. as applicable shall be performed as per applicable standards and codes. The mechanical and chemical testing shall also Be performed in accordance with applicable ASTM material specification.

11.07.02 Non-destructive examinations shall be performed as required by ANSI B81.1 (Power Piping) and ANSI B16.34 (Steel Valves).

11. 07.03 Hydrostatic Test:

- ii) Valve shall be subjected to hydrostatic shell test in accordance with ANSI-B16.34 prior to seat leakage test. If the valves are reworked on the pressure parts for any reason after hydrostatic test, they must be retested.
- iii) Valves shall be hydrostatically tested in manufacturers works in accordance with code requirements. All hydrostatic testing and inspection shall be completed before any paint is applied to valve body. Certificates of inspection shall be executed in accordance with the latest codes and required codes shall be forwarded to the engineer.

All gaskets used for test shall be of the same material and design as specified for the finished product. Where mechanical gasket joints are broken following tests, new gaskets shall be furnished with the equipment, and the joints shall be retested.

11. 07.04 Leakage Test:

- i) Unless otherwise noted in the specification sheets, valve closure test and seat leakage tests shall be performed in accordance with ANSI B16.104, Leakage Class II/class IV as the case may be.
- ii) The leakage from packing shall be zero or bubble tight. For valve designs which are not covered by ANSI B16.104, the bidder shall submit the expected leakage rate with his proposal for review by Owner / Technical Specialist.
- iii) If valves are disassembled after the completion of the valve closure and seat leakage tests, these tests shall be repeated.

11. 07.05 Hysteresis Test :

The hysteresis test shall be run on completely assembled valves. The stuffing box shall be fully packed and made up hand tight. The allowable value of hysteresis specified by the bidder shall be achieved.

11.07.06 Tests for special class valves:

All valves supplied with the special class ratings per ANSI B16.34 "Steel Valves" (except flanged valves) shall be subject to the required examinations as per paragraph 8.3 of ANSI B16.34. the acceptance criteria shall be same as these given in Annexure B,C,D and E of ANSI B16.34 for the applicable examinations expect for the following.



Magnetic particle examination of castings, the linear indication shall not exceed 3/16 inch in length.

11.07.07 Functional Tests:

The fully assembled or completed valves including the operators control devices and accessories shall be functionally tested to demonstrate the operability of the valve and the operation. This may be done by cycling the valves 3 or 4 times from open to close position. The same controller can be used to test each valve. Control valve FI (Liquid pressure recovery factor) in operation test on completed valve (final inspection).



Accessories : Shall be complete with all the accessories including digital display for flow rate, integral vents, baffles for air separation, etc. which ever required for satisfactory operation.

Note:-

1. The above on line flow meter shall not create any obstruction on flow.
2. User's list shall be submitted to support on proven satisfactory performance for similar process application.

3.03.29

Instrument Air System

The instrument Air Supply System for various pneumatic Control & Instrumentation devices like pneumatic actuators, power cylinders, I/P converters, pneumatically operated valves etc. shall be complete in all respect with necessary Air Filter Regulators, valves, piping/tubing etc.. Each pneumatic instrument shall have an individual air shut off valve. The pressure-regulating valve shall be equipped with an internal filter, a 50 mm pressure gauge and a built in filter-housing blow down valve.

Filter shall be of minimum 5-micron size & sintered bronze material.

On collection of water in the drains of instrument air lines, mechanical automatic drains and periodically solenoid operated drains (with electronic timer - 15m, 30m, 60m and 2 Hours & Timing adjustable) are to be provided.

For mechanical type & Electrical type, the locations to be provided in the instrument air lines of boiler area, Chimney area, turbine area etc., shall be decided during detailed Engineering.

Bulk header nearby the crowded applications shall be provided and from this bulk header individual air lines with necessary isolation valves are laid to the application.

These bulk header are to be provided with **mechanical / electronic based automatic Drains.**

Individual moisture separator for O₂ analyzer or vital application shall be provided nearby the instrument so as to enhance the cell life or the performance of vital final control elements.

3.03.30

Air Filter Regulator (AFR)

Constant bleed type AFR with an accuracy of ± 1.0 % inlet pressure range of 5-8 kg/ cm² and suitable spring ranges (AFR) for use with positioners in control valves, control damper, E/P converters and shut off valves for phosphor bronze filter element; Filtering particles above five microns. Weather and water proof enclosure. Material of accessories will be SS316.

Air filter regulators shall be provided in the :

- (a) Air supply line to valve positioners / power cylinders
- (b) Air supply line to electric to pneumatic converters.



- (c) Air supply line to pneumatic interlocked block valves.
- (d) For each instrument rack, field instruments enclosure for purging.

3.03.31 Electro-Pneumatic Convertors (E/P)

Two wire type E/P convertors with an accuracy of $\pm 0.25\%$ accepting 4-20 mA dc signals from control system and converting to 0.2 to 1 kg/cm² air pressure to operate valve positioner of all final control elements; Housed in cast aluminum casing (with polyurethane paint); NEMA 4 or equivalent degree of protection for enclosure. Material of accessories will be SS. E/P convertors shall have fail freeze (stay put) feature also. Process connection shall be 1/4" NPT (F) and Electrical connection shall be 1/2" NPT (F). Zero/span adjustment facility shall be provided. The E to P convertors shall **retain the pneumatic signal (last value) even in failure of control signal** and shall have **self volume boosters**. Necessary air lock devices and pressure switches for air pressure low alarming shall be provided.

3.03.32 Solenoid Valves

Solenoid valves shall be provided with control valves / pneumatic control valves hooked up with process interlock requirements and where direct tripping is involved. The number of ways for solenoid valve shall be provided as indicated below:

- (a) Two (2) way solenoid valves shall be provided, where process line of less than 50 mm with low pressure and temperature application.
- (b) Three (3) way solenoid valve shall be provided commonly, where the pressure is admitted or exhausted from a diaphragm valve or single acting cylinder, e.g, Pneumatic operated spray water block valve.
- (c) Four (4) way solenoid valve shall be provided for operating double acting cylinders, e.g, Pneumatically operated on-off type dampers.
- ~~(d) For operation of the fuel oil corner nozzle valves, fuel oil trip valves etc., **double coil solenoid valve** (latch coil & relatch coil) shall be adopted. **Single coil usage requires always power and loss of power leads to closure of above valves resulting the unit trip or loss of generation.**~~
- (e) Solenoid Valve coils shall be Class-H high-temperature or Class-F construction as applicable and shall be designed for continuous duty. Three-way solenoid valves shall be designed for universal operation so that the supply air may be connected to any port. Solenoid enclosures shall be NEMA-4)/ (Explosion proof for NEC Class-1, Division 1 area)/ flame proof (IEC-79.1, Part I) As applicable). Body material of solenoid valve shall be Die Cast Aluminum or SS316.
- (f) All solenoid shall be with varister, LED indication, surge suppress diode and circuits.

3.03.33 Power Cylinders (Pneumatic)

Mounting Type	:	a) Fixed position mounting (End mounting).
	:	b) Trunnion mounting
Control Signal	:	0.2 to 1 Kg/Sq. cm. from I/P converter for modulating purposes. 24V/48VDC operated solenoid valve operating on pneumatic line.



CONTROL VALVE HOOK-UP DIAGRAM (WITH SMART POSITIONER)

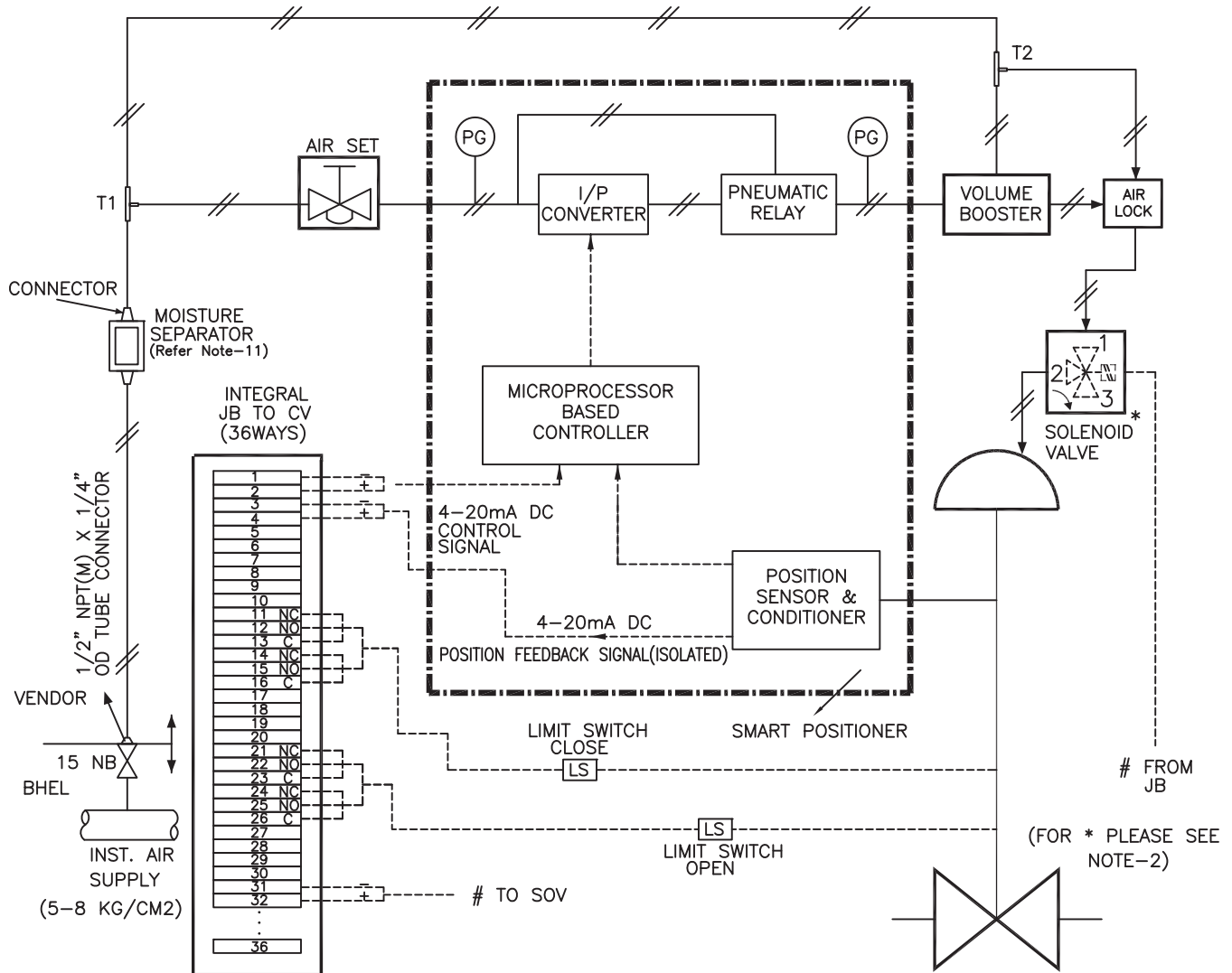

NOTES :-

1. POSITION OF EACH VALVE ON SUPPLY AIR FAILURE / ELECTRICAL SIGNAL FAILURE SHALL BE AS PER SPECIFICATION / DATA SHEET.
2. SOLENOID VALVE WILL BE PROVIDED ONLY FOR CONTROL VALVES IF INDICATED IN RESPECTIVE DATA SHEETS.
3. SOLENOID VALVES PORTS CONDITION:
PORT 1 AND 2 SHALL BE CONNECTED UNDER DE-ENERGISED CONDITION.
PORT 2 AND 3 SHALL BE CONNECTED UNDER ENERGISED CONDITION.
4. PRESSURE GAUGES REQUIRED FOR AIR SUPPLY & OUTPUT(S).
5. MOUNTING ACCESSORIES AS REQUIRED.
6. POSITION FEEDBACK SIGNAL SHALL BE 2 WIRE 4-20mA ISOLATED SIGNAL.
7. JB TERMINALS SHALL BE CAGE CLAMP TYPE SUITABLE FOR 2.5 SQ. MM COPPER WIRE. EXTERNAL CONNECTION THROUGH CABLE GLAND, SHALL BE AS PER DATA SHEET.
8. ALL APPLICABLE ACCESSORIES SHALL BE PROVIDED AS INDICATED IN THE INDIVIDUAL CONTROL VALVE DATA SHEET / ACCESSORIES DATA SHEET.
9. 12 METERS 1/4" SS316 TUBING (AS PER ACCESSORIES DATA SHEET) & 1 SET OF SS316 FITTINGS TO BE SUPPLIED FOR EACH CONTROL VALVE FOR CONNECTION TO ISO VLV AT INST AIR HEADER ON ONE END AND TO AIR LOCK RELAY/AIR FILTER REGULATOR ON THE OTHER END. ALL THE SS316 FITTINGS SHALL BE DOUBLE COMPRESSION TYPE.
10. VOLUME BOOSTER (ALONG WITH TEE-T2 AND RELATED TUBING & CONNECTORS) SHALL BE PROVIDED IF REQUIRED. AIR CONNECTION TO VOLUME BOOSTER FROM TEE-T2 SHALL BE PROVIDED.
11. SEPARATE MOISTURE SEPARATOR TO BE PROVIDED WITH EACH CONTROL VALVE. NECESSARY HARDWARE & SUITABLE CONNECTOR FOR MOUNTING THE MOISTURE SEPARATOR TO BE PROVIDED BY THE BIDDER.
12. ALL REQUIRED ACCESSORIES i.e. SOLENOID OR ANY OTHER HARDWARE REQUIRED TO ACHIEVE STAYPUT AT CONTROLLER SIGNAL FAILURE SHALL BE PROVIDED.
13. DI FOR FAULT SIGNAL OF THE SMART POSITIONER SHALL BE PROVIDED.



2 X 660 MW ENNORE STPP

TITLE:-

CONTROL VALVE HOOK-UP DIAGRAM

DRG.
No.

PE-TS-412-145-1104

REV.
No.

01

DATE

03.09.15

SHEET

41

OF

132

CONTROL VALVE HOOK-UP DIAGRAM (DOUBLE ACTING PISTON ACTUATOR WITH SMART POSITIONER)

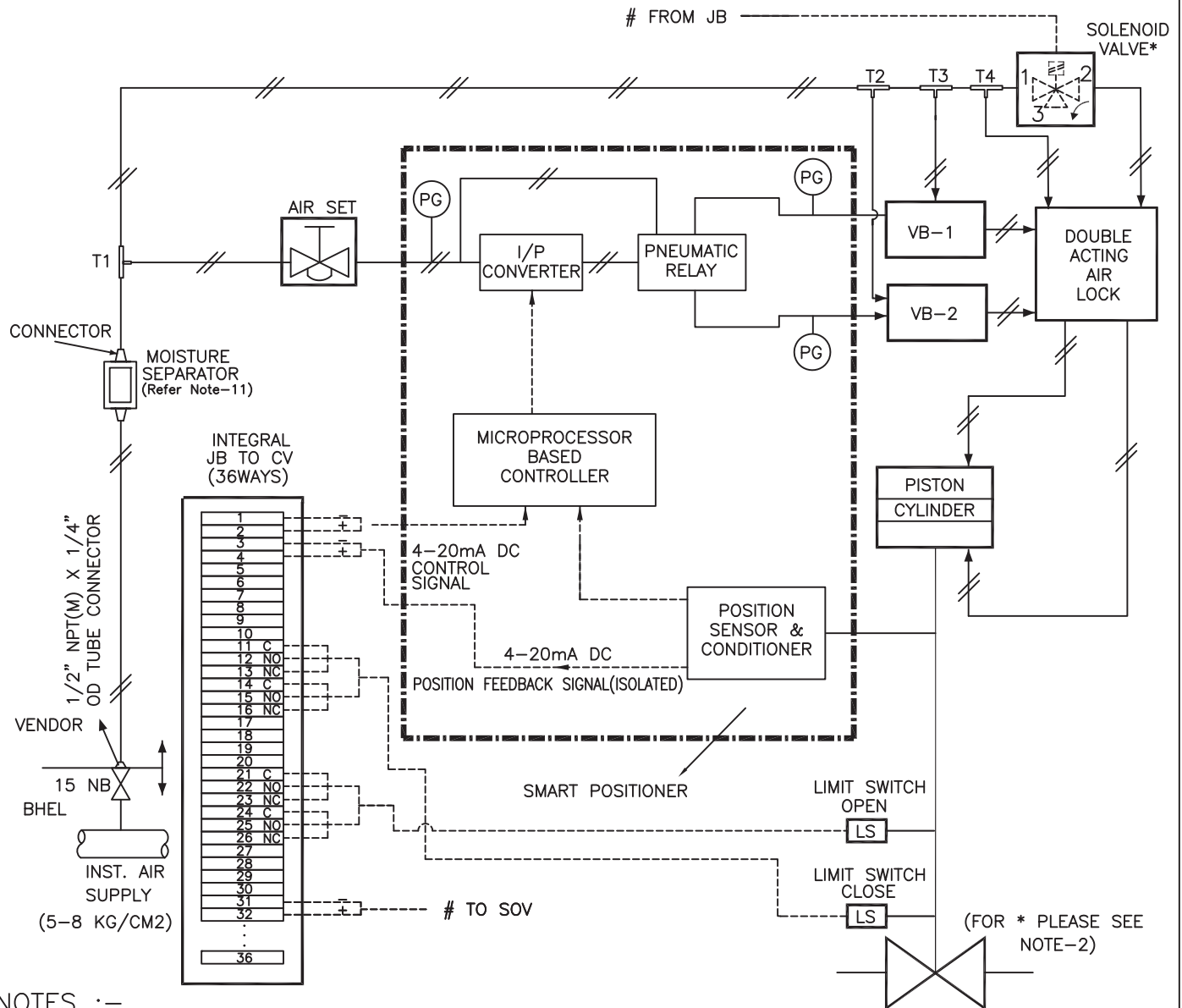

NOTES :-

1. POSITION OF EACH VALVE ON SUPPLY AIR FAILURE / ELECTRICAL SIGNAL FAILURE SHALL BE AS PER SPECIFICATION / DATA SHEET. AIR LOCK SHALL BE PROVIDED ACCORDINGLY.
2. SOLENOID VALVE & LIMIT SWITCHES WILL BE PROVIDED ONLY FOR CONTROL VALVES IF INDICATED IN RESPECTIVE DATA SHEETS.
3. SOLENOID VALVES PORTS CONDITION:
PORT 1 AND 2 SHALL BE CONNECTED UNDER DE-ENERGISED CONDITION.
PORT 2 AND 3 SHALL BE CONNECTED UNDER ENERGISED CONDITION.
4. PRESSURE GAUGES REQUIRED FOR AIR SUPPLY & OUTPUT(S).
5. MOUNTING ACCESSORIES AS REQUIRED.
6. POSITION FEEDBACK SIGNAL SHALL BE 2 WIRE 4-20mA ISOLATED SIGNAL.
7. JB TERMINALS SHALL BE CAGE CLAMP TYPE SUITABLE FOR 2.5 SQ. MM COPPER WIRE. EXTERNAL CONNECTION, OF PLUG IN TYPE OR THROUGH CABLE GLAND, SHALL BE AS PER DATA SHEET
8. ALL APPLICABLE ACCESSORIES SHALL BE PROVIDED AS INDICATED IN THE INDIVIDUAL CONTROL VALVE DATA SHEET / ACCESSORIES DATA SHEET.
9. 12 METERS 1/4" SS TUBING (AS PER ACCESSORIES DATA SHEET) & 1 SET OF FITTINGS TO BE SUPPLIED FOR EACH CONTROL VALVE FOR CONNECTION TO ISO VLV AT INST AIR HEADER ON ONE END AND TO AIR LOCK RELAY/AIR FILTER REGULATOR ON THE OTHER END. ALL THE SS FITTINGS SHALL BE DOUBLE COMPRESSION TYPE.
10. VOLUME BOOSTER (ALONG WITH TEE-T2 AND RELATED TUBING & CONNECTORS) SHALL BE PROVIDED IF REQUIRED. AIR CONNECTION TO VOLUME BOOSTER FROM TEE-T2 & TEE-T3 SHALL BE PROVIDED.
11. SEPARATE MOISTURE SEPARATOR TO BE PROVIDED WITH EACH CONTROL VALVE. NECESSARY HARDWARE & SUITABLE CONNECTOR FOR MOUNTING THE MOISTURE SEPARATOR TO BE PROVIDED BY THE BIDDER.
12. ALL REQUIRED ACCESSORIES i.e. SOLENOID OR ANY OTHER HARDWARE REQUIRED TO ACHIEVE STAYPUT AT CONTROLLER SIGNAL FAILURE SHALL BE PROVIDED.
13. DI FOR FAULT SIGNAL OF THE SMART POSITIONER SHALL BE PROVIDED.



2 X 660 MW ENNORE STPP

TITLE:-

CONTROL VALVE HOOK-UP DIAGRAM

DRG. No.

PE-TS-412-145-1104

REV. No.

01

DATE

03.09.15

SHEET

41A

OF

132

CONTROL VALVE HOOK-UP DIAGRAM (FOR ON / OFF TYPE)

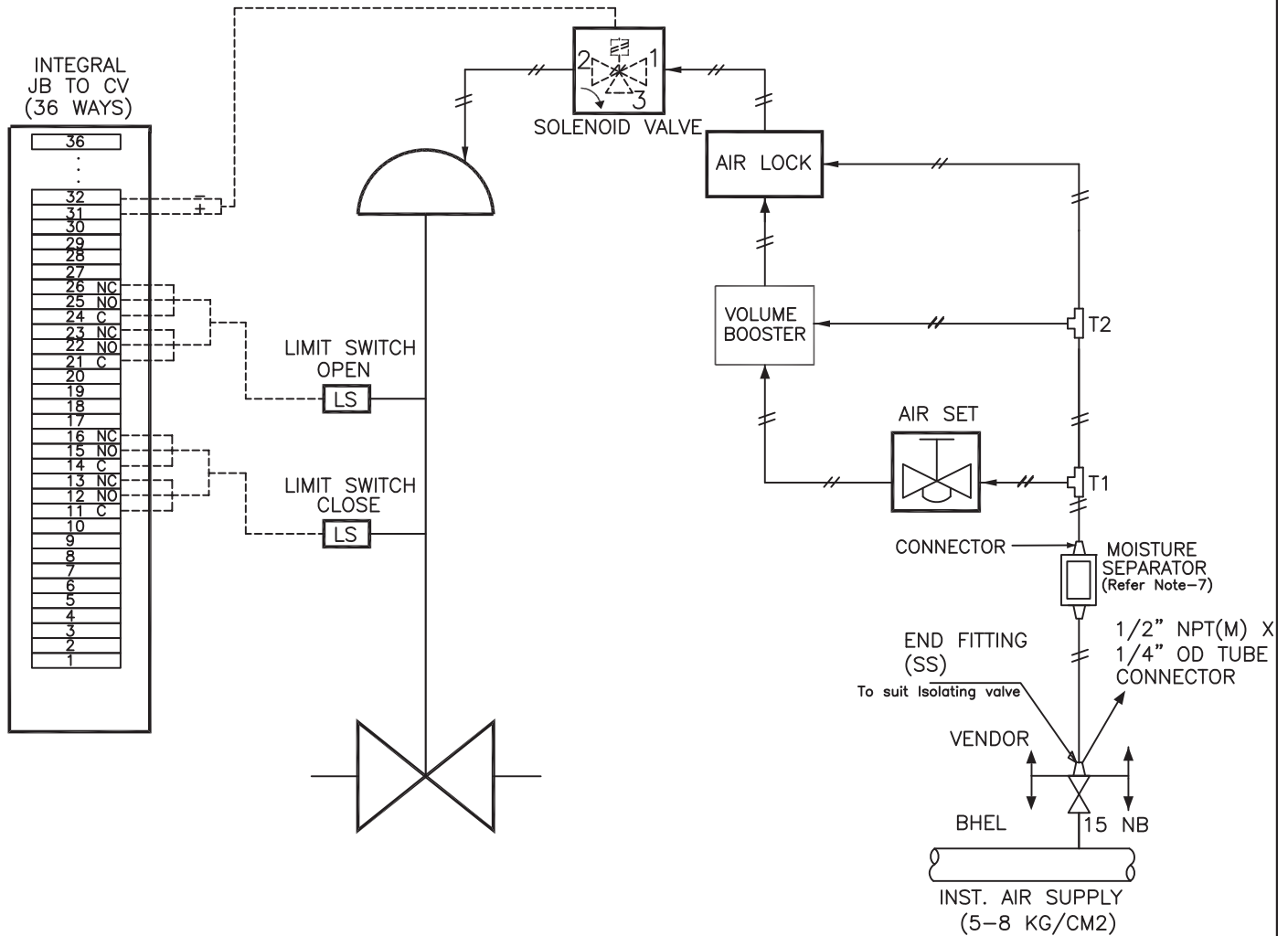

NOTES :-

1. POSITION OF EACH VALVE ON SUPPLY AIR FAILURE / ELECTRIC SIGNAL FAILURE SHALL BE AS PER SPECIFICATION / DATA SHEET.
2. SOLENOID VALVES PORTS CONDITION:
PORT 1 AND 2 SHALL BE CONNECTED UNDER DE-ENERGISED CONDITION.
PORT 2 AND 3 SHALL BE CONNECTED UNDER ENERGISED CONDITION.
3. MOUNTING ACCESSORIES AS REQUIRED.
4. JB TERMINALS SHALL BE CAGE CLAMP TYPE SUITABLE FOR 2.5 SQ. MM COPPER WIRE. EXTERNAL CONNECTION THROUGH CABLE GLAND, SHALL BE AS PER DATA SHEET.
5. ALL APPLICABLE ACCESSORIES SHALL BE PROVIDED AS INDICATED IN THE INDIVIDUAL CONTROL VALVE DATA SHEET / ACCESSORIES DATA SHEET.
6. 12 METERS 1/4" SS316 TUBING (AS PER ACCESSORIES DATA SHEET) & 1 SET OF SS316 FITTINGS TO BE SUPPLIED FOR EACH CONTROL VALVE FOR CONNECTION TO ISO VLV AT INST AIR HEADER ON ONE END AND TO AIR LOCK RELAY/AIR FILTER REGULATOR ON THE OTHER END. ALL THE SS316 FITTINGS SHALL BE DOUBLE COMPRESSION TYPE.
7. SEPARATE MOISTURE SEPARATOR TO BE PROVIDED WITH EACH CONTROL VALVE. NECESSARY HARDWARE & SUITABLE CONNECTOR FOR MOUNTING THE MOISTURE SEPARATOR TO BE PROVIDED BY THE BIDDER.
8. VOLUME BOOSTER (ALONG WITH TEE-T2 AND RELATED TUBING & CONNECTORS) SHALL BE PROVIDED IF REQUIRED. AIR CONNECTION TO VOLUME BOOSTER FROM TEE-T2 SHALL BE PROVIDED.
9. ALL REQUIRED ACCESSORIES i.e. SOLENOID OR ANY OTHER HARDWARE REQUIRED TO ACHIEVE STAYPUT AT CONTROLLER SIGNAL FAILURE SHALL BE PROVIDED.
10. DI FOR FAULT SIGNAL OF THE SMART POSITIONER SHALL BE PROVIDED.



2 X 660 MW ENNORE STPP

DRG.
No.

PE-TS-412-145-I104

TITLE:-

CONTROL VALVE HOOK-UP DIAGRAM

REV.
No.

01

DATE

03.09.15

SHEET

42

OF

132

	<p>Technical specification for Control Valves with Accessories (Pneumatically Operated) 2 X 660 MW ENNORE SEZ STPP</p>	SPECIFICATION NO. PE-TS-412-145-1104	
		VOLUME II-B	
		SECTION D	
		REV. NO. 01	DATE: 03.09.15
		SHEET 43	OF 132

SECTION – D

- **EQUIPMENT SPECIFICATION**
 - **DATA SHEETS – A & B**
- **DATA SHEETS FOR ACCESSORIES**
 - **DATA SHEETS – C**
 - **QUALITY PLAN**
 - **BILL OF QUANTITY**
 - **SPARES**
 - **SUB-VENDORS LIST**
- **SCHEDULE OF SUBMISSION OF DRAWINGS / DOCUMENTS, EQUIPMENT MANUFACTURE INSPECTION AND DESPATCH**



Technical specification for
Control Valves with Accessories
(Pneumatically Operated)
2 X 660 MW ENNORE SEZ STPP

SPEC NO.: PE-TS-412-145-I 104

VOLUME II B

SECTION D

REV. NO. 01 DATE 03.09.15

SHEET 44 OF 132

SECTION-D
EQUIPMENT SPECIFICATION



**SPECIFICATION FOR CONTROL VALVE
(WITH PNEUMATIC / ACTUATOR)**

SPECIFICATION NO.: PES – 145 – 06

VOLUME II B

SECTION D

REV. NO. 05 DATE : 15/05/2007

SHEET 1 OF 11

1.0 SCOPE

This specification covers the Design, Manufacture, Inspection and Testing at the manufacturer's works, proper packing for transportation and delivery to site of Control valve (with Pneumatic/Electric Actuator) for use in Utility/Captive Power Station/Combined Cycle Station.

2.0 CODES AND STANDARDS

- 2.1 All the equipments specified herein shall comply with the requirements of the latest issue of the relevant National and International standards.
- 2.2 The Design and Materials used for the components shall also comply with the relevant National and International standards.
- 2.3 As a minimum requirement, the following standards shall be complied with:-

Indian Boiler Regulation (IBR)	
Allowable Seat leakage	: ANSI-B16.104 / FCI-70.2
Pressure & Temperature ratings	: ANSI-B16.34
Enclosure class	: IEC-144 / NEMA / IS-13947
Control Valves	: ISA S-75
Electric Motor operated Actuators	: IS-9334

3.0 TECHNICAL REQUIREMENTS

The Control valve, Actuator and the accessories shall be suitable for continuous operation under an ambient temperature of 0-55°C and Relative Humidity of 0-95% unless specified otherwise in volume IIB Section-B or Section-C.

3.1 Control Valve

The control valve shall be suitably designed for the operating conditions and system characteristics as specified in the Data Sheet-A.

- 3.1.1 The control valve shall be of globe body design with single port. The valve trim, shall be suitable for quick removal without any cutting or welding.
- 3.1.2 The material of body, internals and packing shall be as specified in the data sheets. Alternatives, considered more suitable for service specified may be given as alternative offer, along with adequate justification. However main offer shall totally meet specification requirements. Asbestos shall not be used for the packing or any other component.
- 3.1.3 The valve bonnet and packing shall be suitable for the service conditions as in Data Sheet-A. Gland sealed type bonnets are not acceptable. Double packing is mandatory for applications involving vacuum service. Bonnets having teflon packing shall have valve stem finished to 2-4 microns. Packing material requiring lubrication will not be acceptable. Justification for proper selection of bonnet & packing shall be furnished in the bid.
- 3.1.4 The valve end connection as specified in Data Sheet-A shall conform to ANSI B16.25 for Butt Weld connection and ANSI B16.5 for flanged ends. End to end dimension shall be as per ANSI 16.10.
- 3.1.5 The valve seat leakage shall be as per ANSI B16.104 / FCI-70.2. The leakage class shall be as per Data Sheet-A.



**SPECIFICATION FOR CONTROL VALVE
(WITH PNEUMATIC / ACTUATOR)**

SPECIFICATION NO.: PES – 145 – 06

VOLUME II B

SECTION D

REV. NO. 05 DATE : 15/05/2007

SHEET 2 OF 11

- 3.1.6 The valve body shall have the direction of flow embossed on all valves.
- 3.1.7 The sizing shall conform to the requirements of ANSI/ISA(S75- 01), and the valve capacity shall be selected so as to meet the following:
- | | | | | |
|--|---|----------------------------|---|--------------------|
| Valve with Linear characteristic. | - | Normal Flow (Design Point) | : | 70-75% valve lift. |
| | - | Max. Flow | : | 90% valve lift. |
| | - | Min. Flow | : | >10% valve lift. |
| Valve with Equipercentage Characteristic | - | Normal Flow (Design Point) | : | 75-85% valve lift. |
| | - | Max. Flow | : | 90% valve lift. |
| | - | Min. Flow | : | >10% valve lift. |
- ON/OFF Quick open Characteristic - 1.1 times the CV calculated on the basis of maximum flow condition.
- 3.1.8 Calculation for valve sizing, velocity and noise shall be subject to purchaser's approval during contract stage. However responsibility of proper selection and design for the duties specified lies with the vendor. Any modifications required to be done on the valves or actuators & accessories to achieve satisfactory performance of the control system shall be done without any commercial implication.
- 3.1.9 Suitable justification and evidence shall be furnished regarding proper selection of the valve.
- 3.1.10 The valve outlet velocities shall be limited to the following values, unless otherwise specified in the Data sheet-A.
- | | | | |
|-----|----------------|----|--|
| i) | Liquid service | <= | 7 Metres/Sec. |
| ii) | Steam service | <= | 1/3 Sonic velocity in the flow medium. |
- 3.1.11 For flashing duty, the trim design shall be such that the vapour bubbles are kept away from valve body.
- 3.1.12 For cavitation service, the trim design shall be of multistage pressure drop type, so as to avoid cavitation altogether, instead of keeping cavitation away from valve parts.
- 3.1.13 In case of predicted noise level above 85 dBA, suitable low noise trim or inbuilt diffusers shall be provided to bring down the noise level below 85dBA.
- 3.1.14 The equivalent weighted sound level measured at 1.5M. above floor level in elevation and one metre horizontally from the control valve expressed in decibels to a reference of 0.0002 microbar shall not exceed 85 dBA (without pipe insulation). The offer shall include noise prediction calculations for each valve.
- 3.1.15 In case of wrong selection/mal operation of valve and for associated actuator during guarantee period, the vendor shall replace the valve suitably with a modified/new valve of design as approved by purchaser and all the expenses for replacement, rectification/modification including transportation both ways will be at vendor's expenses.



**SPECIFICATION FOR CONTROL VALVE
(WITH PNEUMATIC / ACTUATOR)**

SPECIFICATION NO.: PES – 145 – 06

VOLUME II B

SECTION D

REV. NO.

05

DATE : 15/05/2007

SHEET

3

OF 11

3.2 Pneumatic Actuator

The pneumatic actuators shall be employed for modulating or open/close duty, as specified in Data Sheet-A. The bidder shall be responsible for proper selection and sizing of valve actuators in accordance with the pressure drops and shut off pressure.

3.2.1 The pneumatic spring opposed diaphragm actuator for modulating duty shall be capable of positioning the associated valve at desired opening for all the operating conditions specified.

3.2.2 The pneumatic actuator for open/close duty shall be suitable for fast opening/closing of the associated valve.

3.2.3 The actuator design shall allow valve assembly to be mounted at 45° inclination on either side in the vertical plane.

3.2.4 The actuators shall be suitably sized to ensure that the associated valve travel time from full open to full closed position and vice versa is less than 20 seconds under the most stringent service conditions.

3.2.5 The actuator shall be painted with epoxy based paint.

3.3 Accessories for Control valve with Pneumatic Actuator

The bidder shall offer all the accessories as specified in the Data Sheet - A for the Pneumatic Actuators under modulating or OPEN/CLOSE duty. The accessories specified shall be supplied duly mounted on the valve actuator and piped with PVC covered copper tube and flare less brass fittings (Refer typical hook up diagram in sheet 12 of 12).

3.3.1 Hand wheel

Hand wheel shall have OPEN & CLOSE direction marking and clockwise rotation as viewed from front shall close the valve. The hand wheel shall have a circular stainless steel plate with Tag number and service.

3.3.2 Local Position Indicator

Each actuator shall be provided with a mechanical pointer attached to stem, moving over a graduated scale with markings, for OPEN, 25%, 50%, 75%, CLOSE positions.

3.3.3 Position Transmitter

The position transmitter shall be supplied as indicated in Data Sheet-A. The electronic position transmitter shall be non-contact type with 4-20 mA DC 2-wire output suitable for 12-50V DC supply. The resistance type position transmitter shall have 0-100 ohm variation for valve position change of 0-100%. The position transmitters of both types shall have accuracy and enclosure class. Necessary cable glands shall be supplied.



**SPECIFICATION FOR CONTROL VALVE
(WITH PNEUMATIC / ACTUATOR)**

SPECIFICATION NO.: PES – 145 – 06

VOLUME II B

SECTION D

REV. NO. 05 DATE : 15/05/2007

SHEET 4 OF 11

3.3.4 Air Filter Regulator

Instrument quality air at suitable pressure of 5.5 Kg/Cm2(g) to 7 Kg/Cm2(g) shall be supplied to each valve through air filter regulator. The filter regulator shall include an inbuilt blow-down valve, 5 micron size filter. The design pressure for regulator shall be 7 Kg/cm2g. The Air filter regulator shall be selected to meet the requirements of positioner/actuator, E/P convertor and air-lock. The flow capacity of the Air filter regulator shall be variable with a knob. Output gauge shall be provided wherever pneumatic positioner is not specified for the valve.

3.3.5 Air Lock Relay

Air lock relay shall retain the valve position stayput, in case of air supply failure and shall reset automatically on resumption of air supply. Air lock shall have a threaded plug for evacuating diaphragm air if required for local manual operation.

3.3.6 Solenoid Valves

Solenoid valves are meant for interlock & protection purposes overriding the controller signal, and/or to result stayput action on controller signal failure. The Solenoid valve shall be 3-way **Universal** type and the valve internals shall be of stainless steel. The coil shall have class-H insulation and rated for continuous AC/DC duty as specified in Data sheet-A. The enclosure shall be to IP-55. Cable gland shall be provided for cable entry. The solenoid shall in general conform to IS-8935. The solenoid operation shall be universal type. The solenoid shall be suitable for 24V DC supply, unless specified otherwise in Data Sheet-A.

3.3.7 Limit Switches

Limit switches are required as specified in the data sheet-A. Each limit switch shall have 2NO+2NC contacts with contact rating of 5A at 240V AC/0.2A at 220V DC unless otherwise specified. The switch enclosure shall conform to IP-55. Each limit switch shall be supplied with cable glands.

3.3.8 I/P Converter

I/P Converters shall preferably be of force balance type and shall produce pneumatic output signal corresponding to input current signal, also specified in Data Sheet. Convertor electronics shall be protected against reverse connection of signal polarities and a separate external connection shall be provided to facilitate grounding of instrument casing. Cable glands with neoprene gromets suitable for PVC cables shall be provided. I/P convertor shall have span adjustment facility. I/P convertor enclosure shall conform to IP-55 enclosure class.

3.3.9 Positioner

Positioner shall be suitable for accepting controller output signal 0.2-1.0 Kg/cm2, 0.2-0.6 Kg/cm2 or 0.6-1.0 Kg/cm2 as specified and give an output suitable for the actuator. Pneumatic positioner shall have 3 gauges. All gauges shall have metric scales. The positioner input signal range shall be adjustable. Wherever applicable, it shall be possible to bypass the positioner by means of a switch. **Linearity and Hysterisis shall be as indicated in Data sheet-A**

3.3.10 Electro pneumatic Positioner

In place of separate E/P Converter and pneumatic positioner a combined electro pneumatic positioner can also be supplied. The electro pneumatic positioner shall have 2 gauges.

3.3.11 Junction Box



**SPECIFICATION FOR CONTROL VALVE
(WITH PNEUMATIC / ACTUATOR)**

SPECIFICATION NO.: PES – 145 – 06

VOLUME II B

SECTION D

REV. NO. 05

DATE : 15/05/2007

SHEET

5

OF 11

Wherever specified, an integral junction box with all electrical accessories conduited up to JB shall be supplied. The junction box shall have two (2) cable glands for outgoing cables. Junction box shall have enclosure class of IP-55.

3.4 Guarantee & Performance

3.4.1 The overall performance of the control valve with pneumatic actuator assembly shall be as follows:-

i)	Hysteresis	:	\pm 1% of span
ii)	Linearity	:	\pm 2% of span
iii)	Sensitivity	:	\pm 0.5% of span.
iv)	Repeatability	:	\pm 1% of span
v)	Accuracy (Overall)	:	\pm 2% of span

3.4.2 The guarantee for the control valve, pneumatic actuator & accessories shall be for 12 months continuous operation from the date of commissioning, unless specified otherwise in VOL-IIB Section-B or Section-C.

3.5 Electric Actuator

The electric actuator shall be employed for modulating duty.

3.5.1 The actuator assembly shall be complete with drive motors, gears, hand wheel, signaling & switching units, associated control, integral starter, (when specified) and other accessories as required.

3.5.2 The Electric Actuator shall be capable of positioning the associated valve at the desired opening for all the operating conditions.

3.5.3 The motor shall meet the requirements of Current, torque, Axial thrust, Accelerating & stall time as imposed by the driven equipment.

3.5.4 The motor shall be suitable for direct on line starting.

3.5.5 Motors shall be suitable for inching & plugging duty operations.

3.5.6 The motors shall be capable of starting and accelerating to rated speed at 85% of rated voltage.

3.5.7 The motors shall be rated for continuous operations for modulating duty.

3.5.8 The motor shall operate satisfactorily under the following conditions:

- i) \pm 10% supply voltage variation at rated frequency.
- ii) -5% to + 3% variation in frequency at rated supply voltage.

iii) Simultaneous variation in voltage and frequency, the sum of absolute percentage not exceeding 10%.

3.5.9 The Actuator shall be suitable for mounting directly on the valve and shall be suitable for mounting in any position. Supports required for inclined mounting shall form part of supply of valve assembly.

3.5.10 The actuator shall be capable of producing the required torque and thrust at the output shaft for satisfactory operation of the associated valve.



**SPECIFICATION FOR CONTROL VALVE
(WITH PNEUMATIC / ACTUATOR)**

SPECIFICATION NO.: PES – 145 – 06

VOLUME II B

SECTION D

REV. NO. 05 DATE : 15/05/2007

SHEET 6 OF 11

- 3.5.11 Each actuator shall have a hand wheel for emergency operation. The hand wheel shall be designed such that it is declutched automatically when the power supply to the motor is restarted.
- 3.5.12 The hand wheel shall be so arranged that when looking from hand wheel, the valve is closed by rotating the hand wheel in clockwise direction.
- 3.5.13 Motor shall be totally enclosed conforming to IP-65 or better as per data sheet. The enclosure shall be suitable to protect the motor from leakage steam, water or oil from valve joints and glands.
- 3.5.14 Where flameproof enclosures are specified, it shall meet the specification IS-2148.
- 3.5.15 Insulation shall be at least class-B or better and shall be tropicalised to withstand the atmospheric condition.
- 3.5.16 The actuator shall be provided with antifriction bearing in grease filled cartridge.
- 3.5.17 Each actuator shall be provided with a mechanical position indicator to indicate accurately the valve position.
- 3.5.18 The integral starter, if specified in data sheet-A, shall be provided in weatherproof enclosure with protection class not less than IP-65 or better as per data sheet.

The integral starter shall consist of:

- i) Mechanical & Electrically interlocked reversing contractors suitable for class AC4 duty or Thyristor as per data sheet.
- ii) Thermal overload relay.
- iii) Step down control transformer with fuses.
- iv) Interposing relay.
- v) Monitoring relay.
- vi) Open, Close & Stop push buttons.
- vii) Indicating lamps.
- viii) Local-Remote lockable selector switch with spare potential free contacts, wired for remote interface.
- ix) A potential free contact shall be provided for remote annunciation of power failure/overload condition. The contact shall be SPDT, rated for at 5A 240V AC or 0.2A at 220V DC.



**SPECIFICATION FOR CONTROL VALVE
(WITH PNEUMATIC / ACTUATOR)**

SPECIFICATION NO.: PES – 145 – 06

VOLUME II B

SECTION D

REV. NO. 05

DATE : 15/05/2007

SHEET

7

OF 11

- 3.5.19 The actuator shall be suitably time rated for the duty cycle involved with the necessary number of starts per hour, but in no case, less than 1200 starts per hour.
- 3.5.20 The actuator shall be provided with a suitable control unit for receiving 4-20 mA signal from remote controller.
- 3.5.21 The servomotor gear should have self locking or suitable brake so as to maintain it's last position as and when the motor power is switched off.
- 3.5.22 Thermostat/Thermistor as specified in the data sheet shall be provided for sensing the winding temperature and giving trip command. The trip contact shall be change over type. The contact shall be wired up to the actuator terminal box.
- 3.6 Accessories for Control Valve with Electric Actuator
- 3.6.1 Torque Switches
- i) Each actuator shall be provided with at least one open and one close torque switches each with 2 NO+2 NC contacts. The contacts shall be rated for 5A at 240V AC or 0.2A at 220V DC.
 - ii) The torque switches shall have a minimum accuracy $\pm 3\%$ of set value.
 - iii) The torque switches shall be provided with calibrated knobs for setting desired torque. Separate knobs shall be provided for close and open torque switches.
 - iv) The torque switches shall be provided with mechanical latching device to prevent operation when unsealing from the positions. The latching device shall unlatch as soon as the valve leaves the end position. If such provision is not possible, the torque switches shall be bypassed by end position limit switches, which open on valve leaving end position. These limit switches are additional to the number of limit switches specified elsewhere.
 - v) The torque switches or worm gear shall be self-locking type so that when torque switch operates it remains operated until the actuator is operated in the reverse.
 - vi) The torque switch enclosure shall conform to IP-55.
- 3.6.2 Limit Switches
- Each limit switch shall have 2NO+2NC contact with contacts rated for 5A 240V AC/0.2A 220V DC unless otherwise specified. The switch enclosure shall conform to IP-55. Each limit switch shall be supplied with cable glands.
- 3.6.3 Space Heater
- A space heater shall be provided in limit switch and starter compartments to prevent condensation. This shall be suitable for the power supply specified in the data sheet. Where integral starters are provided the space heaters shall be wired to control supply within the actuator.



**SPECIFICATION FOR CONTROL VALVE
(WITH PNEUMATIC / ACTUATOR)**

SPECIFICATION NO.: PES – 145 – 06

VOLUME II B

SECTION D

REV. NO. 05

DATE : 15/05/2007

SHEET

8

OF 11

3.6.4 Remote Position Transmitter

The position transmitter shall be supplied as indicated in Data Sheet-A. The electronic position transmitter shall be non-contact type with 4-20mA DC 2-wire output suitable for 12-50V DC supply. The resistance type position transmitter shall have 0- 100 ohm variation for valve position change of 0-100%. The position transmitters of both types shall have $\pm 1\%$ accuracy. The enclosure shall conform to IP-55. Necessary cable glands shall be supplied.

3.6.5 Wiring

- i) The actuator and the accessories will be neatly wired up to the terminal boxes.
- ii) The internal wiring shall be minimum of 1 mm² stranded PVC insulated copper conductor.
- iii) The wiring shall be identified by means of numbered ferrules on both ends of all wires.

3.7 Terminal and Terminal boxes

3.7.1 Motor Terminal Box

- i) The terminals, terminal boards, terminal boxes, winding tails and associated equipment shall be suitable for connection to supply system having short circuit capacity specified in data sheet and clearance time determined by the associated fuses.
- ii) The terminals shall be stud type insulated from the frame. The insulation shall not be porcelain. The studs shall be of brass or stainless steel or phosphor bronze of adequate size.
- iii) The terminal box shall be totally enclosed conforming to degree of protection IP-65.

3.7.2 Actuator Terminal Box

- i) All terminals of limit and torque switches, space heater, position transmitters, thermostat/thermister shall be brought to a common terminal box. The enclosure shall be to degree of protection IP-65.
- ii) Terminal board with plug in connector shall be provided. Alternatively stud type or insertion type may be considered. Pinch screw type however will not be accepted. All terminals shall be shrouded to prevent accidental contact. Where stud type terminals are offered, it shall be as per clause 3.7.1 (ii).
- iii) There shall be at least five terminals spare to terminate spare cores of cable.

3.7.3 Cable Glands

The motor terminal box and actuator terminal box shall be provided with required number of double compression nickel plated brass cable glands to suit cable type and associated size.

3.7.4 Earthing Terminal

Two earthing terminal shall be provided on either side of motor and actuator terminal box.

3.7.5 Painting

The Actuator shall be painted with epoxy-based paint.



**SPECIFICATION FOR CONTROL VALVE
(WITH PNEUMATIC / ACTUATOR)**

SPECIFICATION NO.: PES – 145 – 06

VOLUME II B

SECTION D

REV. NO. 05 DATE : 15/05/2007

SHEET 9 OF 11

4.0 TESTING AND INSPECTION

4.1 The bidder shall adopt suitable quality assurance plan to ensure that the equipments offered will meet the specification requirements in full.

4.2 The bidder shall furnish the Quality Plan in the format enclosed in volume-III. In case the Quality Plan(s) is/are included in volume-IIB, the bidder shall furnish his Quality Plan strictly in line with the same. The Quality Plan shall be discussed and finalised with the technically accepted bidders before opening the price bid. The stages where purchaser would like to be associated for witnessing or verification of tests would be indicated by the purchaser in the Quality Plan before approval.

4.3 The following test shall be conducted as a minimum requirement.

4.3.1 Control Valve

- i) Radiographic tests on castings.
- ii) Dye penetrant tests on machined surface.
- iii) Ultrasonic tests for the forgings & bars of all valves with 60 Kg/cm² & higher ratings.
- iv) Hydrostatic tests as per ANSI B 16.34 prior to seat leakage tests.
- v) Valve closure and seat leakage tests as per ANSI B 16.104 / FCI-70.2.

4.3.2 Pneumatic Actuators

Functional test of actuator and each accessory.

4.3.3 Electric Actuator

- i) Routine tests on motors as per IS: 325.
- ii) Functional test on actuator and each accessory.
- iii) Insulation resistance and high voltage test.
- iv) Stall current & Stall torque test.
- v) Output shaft speed and torque of actuator and corresponding current tests.

4.3.4 Control valve with Actuator & Accessories fully assembled

- i) Functional tests of control valve operation along with actuator & accessories.
- ii) Dimension checks.

4.3.5 Type tests or Test Reports

- i) Valve lift vs. Flow test (**Cv Test**)
- ii) Degree of protection tests for the enclosures
- ii) Temperature rise test (**applicable for Electrical Actuator only**).
- iii) Type test for motor as per IS: 325.

4.4 Inspection will be conducted by BHEL and/or their authorised representatives as per the agreed inspection schedule. The inspection schedule will be submitted by the bidder, for BHEL's approval at contract stage. The cost of all tests and inspections will be deemed to have been included in the bid. For all the type tests covered under 4.3.5 above, "Type Test Certificates" as per agreed Quality Plan shall be furnished. In the absence of the same, such Type Tests shall be arranged at the Vendor's works in the presence of BHEL and/or their authorised representatives or in independent Test House/Laboratory approved by BHEL.



**SPECIFICATION FOR CONTROL VALVE
(WITH PNEUMATIC / ACTUATOR)**

SPECIFICATION NO.: PES – 145 – 06

VOLUME II B

SECTION D

REV. NO.

05

DATE : 15/05/2007

SHEET

10

OF 11

4.5 The Standard QP is included in this specification to enable bidder to understand the extent of inspection and testing requirements to execute this job. The successful bidder has to follow the agreed QP, taking care of customer requirements mentioned in Sec-C and submit QP for final approval by BHEL / Customer.

5.0 SPARES AND CONSUMABLES

5.1 Commissioning Spares and consumables

As part of the main equipment supply, the bidder shall supply all commissioning spares and consumables required during Start-up,

5.2 Mandatory Spares

The bidder shall offer along with main offer, the Mandatory Spares as specified in Volume IIB Section-C of the specification. The Mandatory Spares offered shall be of the same make and type as the main equipment.

5.3 Recommended Spares

The bidder shall furnish a list of Recommended Spares along with the normal service expectancy period and frequency of replacement; quantities recommended for 3 years operation along with unit rate against each item to enable BHEL / BHEL's Customer to place a separate order later, if required.

5.4 Special Tools & Tackles

The bidder shall furnish a list of Special Tools & Tackles included in the bid.

6.0 DRAWINGS AND DOCUMENTS

6.1 The bidder shall furnish the following documents in required number of copies along with the bid:

6.1.1 Data sheet-B, completely filled-up along with all enclosures.

6.1.2 Wiring diagrams for Electrical Actuators.

6.1.3 Hook up diagrams of Control Valve with Actuator & accessories.

6.1.4 Valve & actuator assembly dimensional drawings with weights.

6.1.5 Quality Plan

6.1.6 All relevant Catalogs with detailed technical information.

6.1.7 Bar-chart to indicate the time schedule for procurement, manufacture, testing and despatch.

6.2 The successful bidder shall furnish the following documents in required number of copies to BHEL during the contract stage:

6.2.1 For approval

i) Dimensional drawings.



**SPECIFICATION FOR CONTROL VALVE
(WITH PNEUMATIC / ACTUATOR)**

SPECIFICATION NO.: PES – 145 – 06

VOLUME II B

SECTION D

REV. NO. 05 DATE : 15/05/2007

SHEET 11 OF 11

- ii) Installation drawings with overall dimensions of the completed equipment and clearances for operation and maintenance.
- iii) Data sheet-C, completely filled-up along with all the enclosures including the sizing calculations & noise calculations.
- iv) Quality Plan.
- v) Test Certificates.

6.2.2 Final / As-built Drawings

Final / As-built drawings / CDs in required number of copies shall be submitted.

6.3 Operation & Maintenance Manuals

O&M Manuals in required number of copies shall be submitted. O&M manuals shall also contain storage and commissioning instructions.

7.0 MARKING AND PACKING

7.1 Marking

A stainless steel metal nameplate should be permanently fixed on each equipment giving its tag number and technical specifications.

7.2 Packing

All equipment / materials shall be suitably packed and protected for the entire period of dispatch, storage and erection against impact, abrasion, corrosion, incidental damage due to vermin, sunlight, high temperature, rain, moisture, humidity, dust, sea water spray (where applicable) as well as rough handling and delays in transit and storage in open.

8.0 APPLICABLE DATA SHEET FORMS

This document shall be read with one or more of the following data sheet forms :

- Data sheet A&B for Control Valve with Pneumatic Actuator : Data sheet no. PES-145-06-DS1-1
- Data sheet C for Control Valve with Pneumatic Actuator : Data sheet no. PES-145-06-DS2-1
- Data sheet A&B for Control Valve with Electric Actuator : Data sheet no. PES-145-06-DS3-1
- Data sheet C for Control Valve with Electric Actuator : Data sheet no. PES-145-06-DS4-1

	Technical specification for Control Valves with Accessories (Pneumatically Operated) 2 X 660 MW ENNORE SEZ STPP	SPECIFICATION NO. PE-TS-412-145-1104	
		VOLUME II-B	
		SECTION D	
		REV. NO. 01	DATE: 03.09.15
		SHEET 56	OF 132

SECTION – D

SPECIFICATION FOR MICROPROCESSOR BASED ELECTRONIC POSITIONER (SMART) (PES – 145 – 06A)

	SPECIFICATIONS FOR MICROPROCESSOR BASED ELECTRONIC POSITIONER (SMART)	SPECIFICATION NO.: PES – 145 – 06A	
		VOLUME	
		SECTION	
		REV. NO. 00	DATE : 19.03.2008
		SHEET 1	OF 4

1.0 Electrical

Input Signal	4-20mA
Power Supply	Loop Powered from the output card of Control System (12-30 V DC)
Hart Protocol	Compatibility For Remote Calibration & Diagnostic (Super-Imposed HART Signal On Input Signal (4-20mA)
Valve Position Feedback (4-20mA)	Position Sensing 4-20mA O/P Signal For Control System To Be Provided. If non contact type of Position feedback signal is required, Position transmitter to be separately provided.

2.0 Environment

Operating Temperature	(-) 30 To 80 Deg.C
Humidity	0-95%
Protection Class	IP-65 (Minimum)

3.0 Software For Configuration & Diagnostic

Software	Windows Based Software, Software Shall Meet The Requirement For Configuration, Diagnostics, Calibration And Testing Of the Actuator. Valve positioning timing, actuator leakage, and Valve Wear & tear, fault alarm to be offered as a minimum. Easily up gradable with same hardware and compatible with any HART management systems / AMS.
Diagnostic/Test Features (Optional)	Advanced Diagnostic Features Like Stroke On Line Partial Closure Test, Valve Signature Analysis (Online graphical representation), Step Response Test, Valve Friction/Jamming Detection Etc To Be Provided.

	SPECIFICATIONS FOR MICROPROCESSOR BASED ELECTRONIC POSITIONER (SMART)	SPECIFICATION NO.: PES – 145 – 06A	
		VOLUME	
		SECTION	
		REV. NO. 00	DATE : 19.03.2008
		SHEET 2	OF 4

Factory Valve Signature Tests Reports (Pr Vs Valve Travel And Travel Vs I/P Signal) Are To Be Provided.

Hardware PC For Configuration/Software (OPTIONAL)

Test Certificates Test Certificates As Per Manufacture Standard/Relevant Standard Are To Be Submitted.

Configuration / Remote Calibration, Auto & Manual Calibration Shall Be Possible.

4.0 Modes

Valve Action	Direct & Reverse, Valve Action. (Same positioner for Single Acting or Double Acting And no separate relays required for changing from Single acting to double).
Flow Characterization	Possible to fit valve characteristic curve linear & Equal percentage
Fail Safe/Fail Freeze (Optional)	Fail Safe/Fail Freeze feature is to be provided.

5.0 Performance

Characteristic Deviation	$\leq 0.75\%$ of span
Ambient temp effect	$\leq 0.01\%$ /Deg C or better.
Dead Band	Adjustable 0.1 to 10%.
Scan Time	10ms
Resolution	$\leq 0.05\%$
Sensitivity/Linearity	0.3-0.4% of FS
Repeatability	0.32% of FS
Auto-Tune	Yes



**SPECIFICATIONS FOR MICROPROCESSOR BASED
ELECTRONIC POSITIONER (SMART)**

SPECIFICATION NO.: PES – 145 – 06A	
VOLUME	
SECTION	
REV. NO. 00	DATE : 19.03.2008
SHEET 3	OF 4

Leak Test Yes

7.0 EMC & CE compliance

Required International Standard Like EN/IEC. To En50081-2&En50082 or equivalent

8.0 Accessories

In Built Operator Panel Display With Push Buttons For Configuration And Display On The Positioner Itself

Hand Held Hart Calibrator (Optional) Universal Hart Calibrator To Be Provided, One Per Unit.

Press Gauge Block For Supply & Output Pr., Filter Regulator Other Accessories Shall Be Provided As On Required Basis For Making System Complete.

Electrical cable entry 1/2-Npt, side or bottom entry to avoid water Ingress.

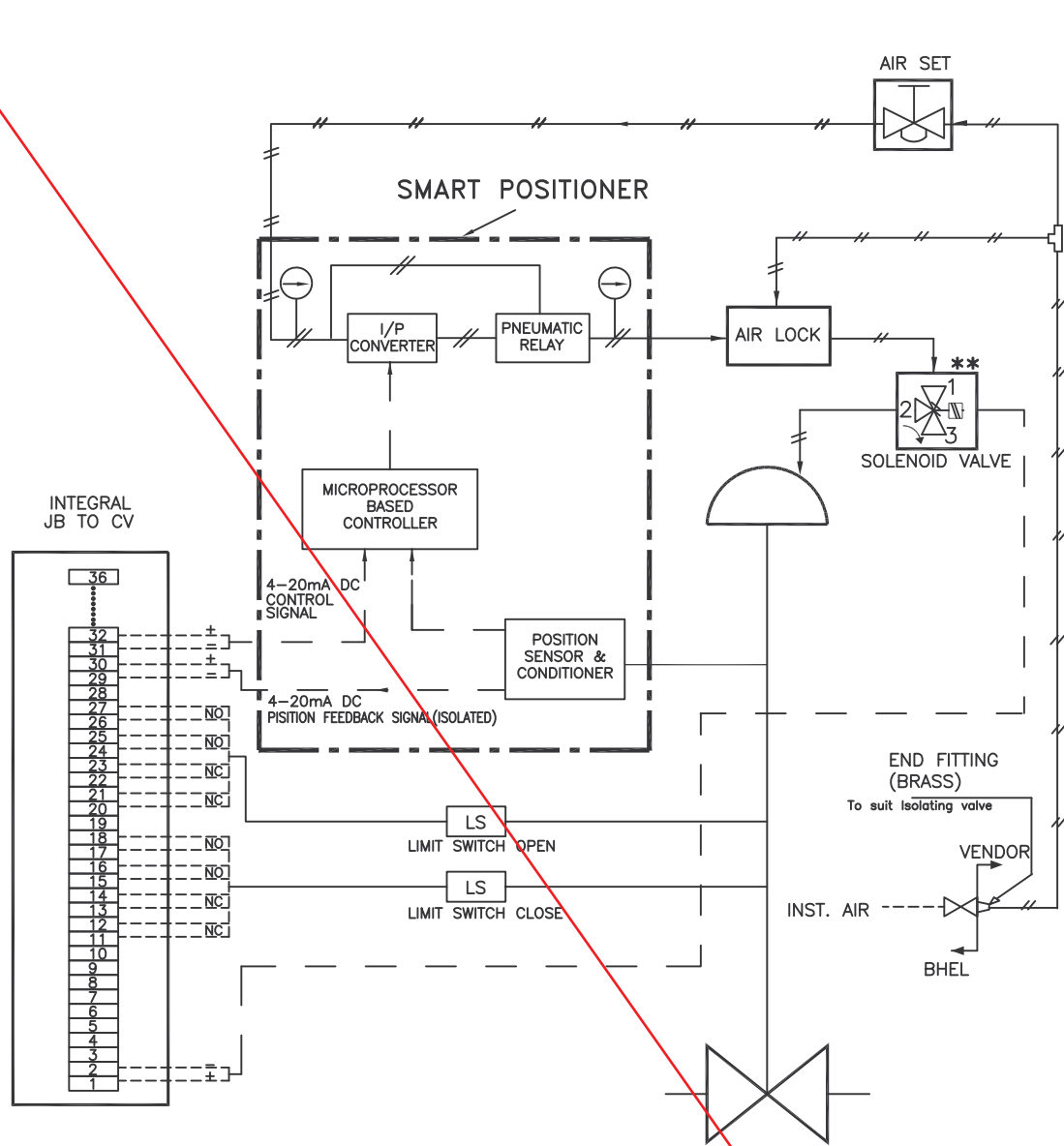

NOTE:—

1. SOLENOID VALVE WILL BE PROVIDED ONLY FOR ON/OFF DUTY VALVES & FOR CONTROL VALVES WHERE OPEN/CLOSE INTERLOCK IS REQUIRED AND INDICATED IN RESPECTIVE DATA SHEETS.
2. SOLENOID VALVES PORT CONDITION:
PORT 1 & 2 SHALL BE CONNECTED UNDER DE-ENERGISED CONDITION.
PORT 2 & 3 SHALL BE CONNECTED UNDER ENERGISED CONDITION.
3. FOR ON/OFF DUTY PNEUMATIC CONTROL VALVE, SMART POSITIONER SHALL NOT BE APPLICABLE.
4. JB TERMINALS SHALL BE CAGE CLAMP TYPE SUITABLE FOR 2.5 SQ. MM COPPER WIRE.
5. 10 METERS 1/4 " PVC COATED COPPER TUBING AND 1 SET OF FITTINGS TO BE SUPPLIED FOR EACH CONTROL VALVE FOR CONNECTION TO ISO VALVE AT INST AIR HEADER ON ONE END AND TO AIR LOCK RELAY/AIR FILTER REGULATOR ON THE OTHER END.
6. VOLUME BOOSTER IF REQUIRED SHALL BE PROVIDED.

** APPLICABLE TO VALVES WHERE OPEN/CLOSE ACTION REQUIRED ON INTERLOCK CONDITION



Technical specification for
Control Valves with Accessories
(Pneumatically Operated)

2 X 660 MW ENNORE SEZ STPP

SPEC NO.: PE-TS-412-145-I 104

VOLUME II B

SECTION D

REV. NO. 01 DATE 03.09.15

SHEET 61 OF 132

SECTION-D

DATA SHEETS - A&B

BHEL PEM	DATA SHEET FOR CONTROL VALVES (WITH PNEUMATIC ACTUATOR) 2 X 660 MW ENNORE STPP	SPECIFICATION NO.: PE-TS-412-145-I104		
		VOLUME	IIB	
		SECTION	D	
		REV. NO.	01	DATE : 03.09.15
		SHEET	62	OF 135

Tag No. :...ASV-8...
KKS No. LBG51AA101

Qty.: ...1 per Unit ...

Date Sheet No. PES-145-06-DS1-0

DATA SHEET – A & B

DATA SHEET – A FOR CONTROL VALVE (WITH PNEUMATIC ACTUATOR) (TO BE FILLED BY PURCHASER)		DATA SHEET – B (TO BE FILLED UP BY BIDDER)
GENERAL	PROJECT SERVICE LOCATION DUTY PIPE SIZE (inlet / outlet) PIPE MATERIAL (inlet / outlet)	TANGEDCO - 2x660 MW ENNORE STPP D/A PEGGING FROM AUX. STEAM HEADER <input checked="" type="checkbox"/> INDOOR <input type="checkbox"/> OUTDOOR <input type="checkbox"/> ON/OFF <input checked="" type="checkbox"/> MODULATING 323.9 x 9.53 559 x 10 SA 106 GR B SA 672 GR B70
BODY	MODEL NO. TYPE OF BODY: GUIDING: NO. OF PORTS BODY SIZE: PORT SIZE: DESIGN CV END CONNECTION & RATING (ANSI) BODY MATERIAL PACKING: MATERIAL SINGLE / DOUBLE BONNET TYPE TRIM FORM TRIM MATERIAL: SEAT PLUG : CAGE GUIDE BUSH FLOW OUTLET VELOCITY REQUIRED LEAKAGE CLASS NOISE LEVEL (dBA) (at 1 meter) VACUUM SERVICE ANTI CAVITATION TRIM	BIDDER TO INDICATE <input checked="" type="checkbox"/> GLOBE <input type="checkbox"/> ANGLE <input type="checkbox"/> TOP <input checked="" type="checkbox"/> CAGE ONE BIDDER TO INDICATE <input checked="" type="checkbox"/> BWE <input type="checkbox"/> SWE <input type="checkbox"/> FLANGED <input type="checkbox"/> A216 WCB <input checked="" type="checkbox"/> A217 WC9 <input type="checkbox"/> SS <input type="checkbox"/> A217 CS <input type="checkbox"/> A351 CF8M <input type="checkbox"/> PTFE <input checked="" type="checkbox"/> GRAFOIL <input type="checkbox"/> DOUBLE <input checked="" type="checkbox"/> SINGLE BIDDER TO INDICATE <input checked="" type="checkbox"/> LINEAR <input type="checkbox"/> EQ. PERCENTAGE <input type="checkbox"/> QUICK OPEN (ON/OFF) SS 316 STELLITED SS 316 STELLITED SS 316 STELLITED SS 316 STELLITED BIDDER TO INDICATE <input type="checkbox"/> < 7 M/SEC (WATER) <input checked="" type="checkbox"/> MAC NO. < 1/3 (STM) <input type="checkbox"/> II <input type="checkbox"/> III <input checked="" type="checkbox"/> IV <input type="checkbox"/> V <input type="checkbox"/> VI LESS THAN 85 dBA <input type="checkbox"/> YES <input checked="" type="checkbox"/> NO <input type="checkbox"/> YES <input checked="" type="checkbox"/> NO
PNEUMATIC ACTUATOR	MODEL NO. & SIZE CLOSE AT : OPEN AT (KG/CM2g) TRAVEL TIME FOR OPEN TO CLOSE, CLOSE TO OPEN VALVE POSN. ON SIGNAL AIR FAILURE VALVE POSN. ON SUPPLY AIR FAILURE	BIDDER TO INDICATE TO SUIT ACTUATOR <10 SEC <input checked="" type="checkbox"/> TO OPEN <input type="checkbox"/> STAYPUT <input type="checkbox"/> TO CLOSE <input checked="" type="checkbox"/> STAYPUT
ACCESSORI ES	POSITIONER (SMART) AIR FILTER REGULATOR AIR LOCK RELAY POSITION LIMIT SWITCH POSITION TRANSMITTER SOLENOID VALVE E/P CONVERTER JUNCTION BOX HAND WHEEL (SIDE MOUNTED) LOCAL POSITION INDICATOR ELECTRO PNEUMATIC POSITIONER MOISTURE SEPARATOR	<input checked="" type="checkbox"/> REQUIRED <input type="checkbox"/> NOT REQUIRED <input checked="" type="checkbox"/> REQUIRED <input type="checkbox"/> NOT REQUIRED <input checked="" type="checkbox"/> REQUIRED <input type="checkbox"/> NOT REQUIRED <input checked="" type="checkbox"/> REQUIRED <input type="checkbox"/> NOT REQUIRED PART OF POSITIONER <input checked="" type="checkbox"/> REQUIRED <input type="checkbox"/> NOT REQUIRED PART OF POSITIONER <input checked="" type="checkbox"/> REQUIRED <input type="checkbox"/> NOT REQUIRED <input checked="" type="checkbox"/> REQUIRED <input checked="" type="checkbox"/> REQUIRED <input type="checkbox"/> REQUIRED <input checked="" type="checkbox"/> NOT REQUIRED <input checked="" type="checkbox"/> REQUIRED

BHEL PEM	DATA SHEET FOR CONTROL VALVES (WITH PNEUMATIC ACTUATOR) 2 X 660 MW ENNORE STPP	SPECIFICATION NO.: PE-TS-412-145-I104		
		VOLUME	IIB	
		SECTION	D	
		REV. NO.	01	DATE : 03.09.15
		SHEET	64	OF 135

Tag No. :...CRHV-6... Qty.: ...1 per Unit ...
KKS No. LBQ10AA101

Date Sheet No. PES-145-06-DS1-0

DATA SHEET – A & B

DATA SHEET – A FOR CONTROL VALVE (WITH PNEUMATIC ACTUATOR) (TO BE FILLED BY PURCHASER)	DATA SHEET – B (TO BE FILLED UP BY BIDDER)
---	--

GENERAL	PROJECT SERVICE LOCATION DUTY PIPE SIZE (inlet / outlet) PIPE MATERIAL (inlet / outlet)	TANGEDCO - 2x660 MW ENNORE STPP D/A PEGGING FROM CRH LINE <input checked="" type="checkbox"/> INDOOR <input type="checkbox"/> OUTDOOR <input type="checkbox"/> ON/OFF <input checked="" type="checkbox"/> MODULATING 355.6 x 15.09 965 x 34 SA 106 GR C SA 106 GR C
---------	--	--

BODY	MODEL NO. TYPE OF BODY: GUIDING: NO. OF PORTS BODY SIZE: PORT SIZE: DESIGN CV END CONNECTION & RATING (ANSI) BODY MATERIAL PACKING: MATERIAL SINGLE / DOUBLE BONNET TYPE TRIM FORM TRIM MATERIAL: SEAT PLUG : CAGE GUIDE BUSH FLOW OUTLET VELOCITY REQUIRED LEAKAGE CLASS NOISE LEVEL (dBA) (at 1 meter) VACUUM SERVICE ANTI CAVITATION TRIM	BIDDER TO INDICATE <input checked="" type="checkbox"/> GLOBE <input type="checkbox"/> ANGLE <input type="checkbox"/> TOP <input checked="" type="checkbox"/> CAGE ONE BIDDER TO INDICATE <input checked="" type="checkbox"/> BWE <input type="checkbox"/> SWE <input type="checkbox"/> FLANGED <input type="checkbox"/> A216 WCB <input checked="" type="checkbox"/> A217 WC9 <input type="checkbox"/> SS <input type="checkbox"/> A217 CS <input type="checkbox"/> A351 CF8M <input type="checkbox"/> PTFE <input checked="" type="checkbox"/> GRAFOIL <input type="checkbox"/> DOUBLE <input checked="" type="checkbox"/> SINGLE BIDDER TO INDICATE <input checked="" type="checkbox"/> LINEAR <input type="checkbox"/> EQ. PERCENTAGE <input type="checkbox"/> QUICK OPEN (ON/OFF) SS 316 STELLITED SS 316 STELLITED SS 316 STELLITED SS 316 STELLITED BIDDER TO INDICATE <input type="checkbox"/> < 7 M/SEC (WATER) <input checked="" type="checkbox"/> MAC NO. < 1/3(STM) <input type="checkbox"/> II <input type="checkbox"/> III <input checked="" type="checkbox"/> IV <input type="checkbox"/> V <input type="checkbox"/> VI LESS THAN 85 dBA <input type="checkbox"/> YES <input checked="" type="checkbox"/> NO <input type="checkbox"/> YES <input checked="" type="checkbox"/> NO
------	---	---

PNEUMATIC ACTUATOR	MODEL NO. & SIZE CLOSE AT : OPEN AT (KG/CM2g) TRAVEL TIME FOR OPEN TO CLOSE, CLOSE TO OPEN VALVE POSN. ON SIGNAL AIR FAILURE VALVE POSN. ON SUPPLY AIR FAILURE	BIDDER TO INDICATE TO SUIT ACTUATOR <10 SEC <input type="checkbox"/> TO OPEN <input type="checkbox"/> STAYPUT <input checked="" type="checkbox"/> TO CLOSE <input checked="" type="checkbox"/> STAYPUT
--------------------	---	--

ACCESSORIES	POSITIONER (SMART) AIR FILTER REGULATOR AIR LOCK RELAY POSITION LIMIT SWITCH POSITION TRANSMITTER SOLENOID VALVE E/P CONVERTER JUNCTION BOX HAND WHEEL (SIDE MOUNTED) LOCAL POSITION INDICATOR ELECTRO PNEUMATIC POSITIONER MOISTURE SEPARATOR	<input checked="" type="checkbox"/> REQUIRED <input type="checkbox"/> NOT REQUIRED <input checked="" type="checkbox"/> REQUIRED <input type="checkbox"/> NOT REQUIRED <input checked="" type="checkbox"/> REQUIRED <input type="checkbox"/> NOT REQUIRED <input checked="" type="checkbox"/> REQUIRED <input type="checkbox"/> NOT REQUIRED PART OF POSITIONER <input checked="" type="checkbox"/> REQUIRED <input type="checkbox"/> NOT REQUIRED PART OF POSITIONER <input checked="" type="checkbox"/> REQUIRED <input type="checkbox"/> NOT REQUIRED <input checked="" type="checkbox"/> REQUIRED <input checked="" type="checkbox"/> REQUIRED <input type="checkbox"/> REQUIRED <input checked="" type="checkbox"/> NOT REQUIRED <input checked="" type="checkbox"/> REQUIRED
-------------	---	--

BHEL PEM	DATA SHEET FOR CONTROL VALVES (WITH PNEUMATIC ACTUATOR) 2 X 660 MW ENNORE STPP		SPECIFICATION NO.: PE-TS-412-145-1104		
			VOLUME IIB		
			SECTION D		
			REV. NO. 01	DATE : 03.09.15	
			SHEET 69	OF 135	

Tag No. :...CDV-39... Qty.: ...1 per Unit ...
KKS No. LCA31AA101

Date Sheet No. PES-145-06-DS1-0

DATA SHEET – A & B

DATA SHEET – A FOR CONTROL VALVE (WITH PNEUMATIC ACTUATOR) (TO BE FILLED BY PURCHASER)				DATA SHEET – B (TO BE FILLED UP BY BIDDER)	
PERFORMANCE OF VALVE	LINEARITY	± 1%		
	HYSTERISIS	± 1%		
	SENSITIVITY	± 0.5%		
	ACCURACY (OVERALL)	± 1%		

SERVICE CONDITION	SL. No. +	LOAD	FLOW (T/HR)	INLET PR. KG/CM2(A)	OUTLET PR. KG/CM2(A)	TEMP DEG (C)	CALC ULATED CV	% VLV LIFT	VLV O/L VELOCITY
		1.	MIN.	32.4	35.4	0.2	46.3		
	2.	MAX	324	30.3	0.5	46.4			
	VALVE TYPE						<input checked="" type="checkbox"/> CAVITATION <input type="checkbox"/> FLASHING <input checked="" type="checkbox"/> HIGH DP		
	MAX SHUT OFF PRESS (KG/CM2g)			45				
	BODY DESIGN : PRESS (KG/CM2g) TEMP (DEG C)			45/VACUUM 60				
	IBR FORM III-C			<input type="checkbox"/> REQUIRED <input checked="" type="checkbox"/> NOT REQUIRED				
	TOTAL WEIGHT (VALVE + ACTUATOR + ACCESSORIES) Kg							

BHEL PEM	DATA SHEET FOR CONTROL VALVES (WITH PNEUMATIC ACTUATOR) 2 X 660 MW ENNORE STPP	SPECIFICATION NO.: PE-TS-412-145-1104		
		VOLUME	IIB	
		SECTION	D	
		REV. NO.	01	DATE : 03.09.15
		SHEET	70	OF 135

Tag No. :...CDV-43... Qty.: ...1 per Unit ...
KKS No. LCA41AA101

Date Sheet No. PES-145-06-DS1-0

DATA SHEET – A & B

DATA SHEET – A FOR CONTROL VALVE (WITH PNEUMATIC ACTUATOR) (TO BE FILLED BY PURCHASER)		DATA SHEET – B (TO BE FILLED UP BY BIDDER)
GENERAL	PROJECT SERVICE LOCATION DUTY PIPE SIZE (inlet / outlet) PIPE MATERIAL (inlet / outlet)	TANGEDCO - 2x660 MW ENNORE STPP EXCESS RETURN TO CST <input checked="" type="checkbox"/> INDOOR <input type="checkbox"/> OUTDOOR <input type="checkbox"/> ON/OFF <input checked="" type="checkbox"/> MODULATING 219.1 x 8.18 219.1 x 8.18 SA 106 GR C SA 106 GR C
BODY	MODEL NO. TYPE OF BODY: GUIDING : NO. OF PORTS BODY SIZE: PORT SIZE: DESIGN CV END CONNECTION & RATING (ANSI) BODY MATERIAL PACKING: MATERIAL SINGLE / DOUBLE BONNET TYPE TRIM FORM TRIM MATERIAL: SEAT PLUG : CAGE GUIDE BUSH FLOW OUTLET VELOCITY REQUIRED LEAKAGE CLASS NOISE LEVEL (dBA) (at 1 meter) VACUUM SERVICE ANTI CAVITATION TRIM	BIDDER TO INDICATE <input checked="" type="checkbox"/> GLOBE <input type="checkbox"/> ANGLE <input type="checkbox"/> TOP <input checked="" type="checkbox"/> CAGE ONE BIDDER TO INDICATE <input checked="" type="checkbox"/> BWE <input type="checkbox"/> SWE <input type="checkbox"/> FLANGED <input type="checkbox"/> A216 WCB <input checked="" type="checkbox"/> A217 WC6 <input type="checkbox"/> SS <input type="checkbox"/> A217 CS <input type="checkbox"/> A351 CF8M <input type="checkbox"/> PTFE <input checked="" type="checkbox"/> GRAFOIL <input type="checkbox"/> DOUBLE <input checked="" type="checkbox"/> SINGLE BIDDER TO INDICATE <input checked="" type="checkbox"/> LINEAR <input type="checkbox"/> EQ. PERCENTAGE <input type="checkbox"/> QUICK OPEN (ON/OFF) 17-4 PH SS 17-4 PH SS 17-4 PH SS 17-4 PH SS BIDDER TO INDICATE <input checked="" type="checkbox"/> < 7 M/SEC (WATER) <input type="checkbox"/> MAC NO. < 1/3(STM) <input type="checkbox"/> II <input type="checkbox"/> III <input checked="" type="checkbox"/> IV <input type="checkbox"/> V <input type="checkbox"/> VI LESS THAN 85 dBA <input type="checkbox"/> YES <input checked="" type="checkbox"/> NO <input checked="" type="checkbox"/> YES <input type="checkbox"/> NO
PNEUMATIC ACTUATOR	MODEL NO. & SIZE CLOSE AT : OPEN AT (KG/CM2g) TRAVEL TIME FOR OPEN TO CLOSE, CLOSE TO OPEN VALVE POSN. ON SIGNAL AIR FAILURE VALVE POSN. ON SUPPLY AIR FAILURE	BIDDER TO INDICATE TO SUIT ACTUATOR <10 SEC <input type="checkbox"/> TO OPEN <input checked="" type="checkbox"/> STAYPUT <input type="checkbox"/> TO CLOSE <input checked="" type="checkbox"/> STAYPUT
ACCESSORIES	POSITIONER (SMART) AIR FILTER REGULATOR AIR LOCK RELAY POSITION LIMIT SWITCH POSITION TRANSMITTER SOLENOID VALVE E/P CONVERTER JUNCTION BOX HAND WHEEL (SIDE MOUNTED) LOCAL POSITION INDICATOR ELECTRO PNEUMATIC POSITIONER MOISTURE SEPARATOR	<input checked="" type="checkbox"/> REQUIRED <input type="checkbox"/> NOT REQUIRED <input checked="" type="checkbox"/> REQUIRED <input type="checkbox"/> NOT REQUIRED <input checked="" type="checkbox"/> REQUIRED <input type="checkbox"/> NOT REQUIRED <input checked="" type="checkbox"/> REQUIRED <input type="checkbox"/> NOT REQUIRED PART OF POSITIONER <input type="checkbox"/> REQUIRED <input checked="" type="checkbox"/> NOT REQUIRED PART OF POSITIONER <input checked="" type="checkbox"/> REQUIRED <input type="checkbox"/> NOT REQUIRED <input checked="" type="checkbox"/> REQUIRED <input checked="" type="checkbox"/> REQUIRED <input type="checkbox"/> REQUIRED <input checked="" type="checkbox"/> NOT REQUIRED <input checked="" type="checkbox"/> REQUIRED

BHEL PEM	DATA SHEET FOR CONTROL VALVES (WITH PNEUMATIC ACTUATOR) 2 X 660 MW ENNORE STPP		SPECIFICATION NO.: PE-TS-412-145-I104			
			VOLUME	IIB		
			SECTION	D		
			REV. NO.	01	DATE :	03.09.15
			SHEET	72	OF	135
Tag No. :...CDV-67... Qty.: ...1 per Unit ... KKS No. LCA34AA101		Date Sheet No. PES-145-06-DS1-0				
DATA SHEET – A & B						
DATA SHEET – A FOR CONTROL VALVE (WITH PNEUMATIC ACTUATOR) (TO BE FILLED BY PURCHASER)				DATA SHEET – B (TO BE FILLED UP BY BIDDER)		
GENERAL	PROJECT	TANGEDCO - 2x660 MW ENNORE STPP			
	SERVICE	CONDENSATE SPRAY TO FLASH TANK-B			
BODY	LOCATION	<input checked="" type="checkbox"/> INDOOR <input type="checkbox"/> OUTDOOR			
	DUTY	<input checked="" type="checkbox"/> ON/OFF <input type="checkbox"/> MODULATING			
	PIPE SIZE (inlet / outlet)	33.4 x 4.55	33.4 x 4.55		
	PIPE MATERIAL (inlet / outlet)	SA 106 GR B	SA 106 GR B		
	MODEL NO.	BIDDER TO INDICATE			
	TYPE OF BODY: GUIDING: NO. OF PORTS	<input checked="" type="checkbox"/> GLOBE <input type="checkbox"/> ANGLE <input type="checkbox"/> TOP <input checked="" type="checkbox"/> CAGE ONE			
	BODY SIZE: PORT SIZE: DESIGN CV	BIDDER TO INDICATE			
	END CONNECTION & RATING (ANSI)	<input type="checkbox"/> BWE <input checked="" type="checkbox"/> SWE <input type="checkbox"/> FLANGED			
	BODY MATERIAL	<input type="checkbox"/> A216 WCB <input checked="" type="checkbox"/> A217 WC6 <input type="checkbox"/> SS <input type="checkbox"/> A217 CS			
		<input type="checkbox"/> A351 CF8M			
	PACKING: MATERIAL SINGLE / DOUBLE	<input type="checkbox"/> PTFE <input checked="" type="checkbox"/> GRAFOIL <input checked="" type="checkbox"/> DOUBLE <input type="checkbox"/> SINGLE			
	BONNET TYPE	BIDDER TO INDICATE			
	TRIM FORM	<input type="checkbox"/> LINEAR <input type="checkbox"/> EQ. PERCENTAGE			
	TRIM MATERIAL: SEAT PLUG	<input checked="" type="checkbox"/> QUICK OPEN (ON/OFF)			
	: CAGE GUIDE BUSH	17-4 PH SS 17-4 PH SS			
		17-4 PH SS 17-4 PH SS			
	FLOW	BIDDER TO INDICATE			
	OUTLET VELOCITY	<input checked="" type="checkbox"/> < 7 M/SEC (WATER) <input type="checkbox"/> MAC NO. < 1/3(STM)			
	REQUIRED LEAKAGE CLASS	<input type="checkbox"/> II <input type="checkbox"/> III <input checked="" type="checkbox"/> IV <input type="checkbox"/> V <input type="checkbox"/> VI			
	NOISE LEVEL (dBA) (at 1 meter)	LESS THAN 85 dBA			
	VACUUM SERVICE	<input checked="" type="checkbox"/> YES <input type="checkbox"/> NO			
	ANTI CAVITATION TRIM	<input checked="" type="checkbox"/> YES <input type="checkbox"/> NO			
PNEUMATIC ACTUATOR	MODEL NO. & SIZE	BIDDER TO INDICATE			
	CLOSE AT : OPEN AT (KG/CM2g)	TO SUIT ACTUATOR			
	TRAVEL TIME FOR	<10 SEC			
	OPEN TO CLOSE, CLOSE TO OPEN				
	VALVE POSN. ON SIGNAL AIR FAILURE	<input checked="" type="checkbox"/> TO OPEN <input type="checkbox"/> STAYPUT <input type="checkbox"/> TO CLOSE			
	VALVE POSN. ON SUPPLY AIR FAILURE	<input checked="" type="checkbox"/> STAYPUT			
ACCESSORI ES	POSITIONER (SMART)	<input type="checkbox"/> REQUIRED <input checked="" type="checkbox"/> NOT REQUIRED			
	AIR FILTER REGULATOR	<input checked="" type="checkbox"/> REQUIRED <input type="checkbox"/> NOT REQUIRED			
	AIR LOCK RELAY	<input checked="" type="checkbox"/> REQUIRED <input type="checkbox"/> NOT REQUIRED			
	POSITION LIMIT SWITCH	<input checked="" type="checkbox"/> REQUIRED <input type="checkbox"/> NOT REQUIRED			
	POSITION TRANSMITTER	<input type="checkbox"/> REQUIRED <input checked="" type="checkbox"/> NOT REQUIRED			
	SOLENOID VALVE	<input checked="" type="checkbox"/> REQUIRED <input type="checkbox"/> NOT REQUIRED			
	E/P CONVERTER	<input type="checkbox"/> REQUIRED <input checked="" type="checkbox"/> NOT REQUIRED			
	JUNCTION BOX	<input checked="" type="checkbox"/> REQUIRED <input type="checkbox"/> NOT REQUIRED			
	HAND WHEEL (SIDE MOUNTED)	<input checked="" type="checkbox"/> REQUIRED			
	LOCAL POSITION INDICATOR	<input checked="" type="checkbox"/> REQUIRED			
	ELECTRO PNEUMATIC POSITIONER	<input type="checkbox"/> REQUIRED <input checked="" type="checkbox"/> NOT REQUIRED			
MOISTURE SEPARATOR	<input checked="" type="checkbox"/> REQUIRED				

BHEL PEM	DATA SHEET FOR CONTROL VALVES (WITH PNEUMATIC ACTUATOR)	SPECIFICATION NO.: PE-TS-412-145-1104	
		VOLUME	IIB
		SECTION	D
		REV. NO.	01 DATE : 03.09.15
2 X 660 MW ENNORE STPP		SHEET	73 OF 135

Tag No. :...CDV-67... Qty.: ...1 per Unit ... Date Sheet No. PES-145-06-DS1-0
 KKS No. LCA34AA101

DATA SHEET – A & B

DATA SHEET – A FOR CONTROL VALVE (WITH PNEUMATIC ACTUATOR) (TO BE FILLED BY PURCHASER)	DATA SHEET – B (TO BE FILLED UP BY BIDDER)
---	---

PERFORMANCE OF VALVE	LINEARITY HYSTERESIS SENSITIVITY ACCURACY (OVERALL)	NA NA NA NA
----------------------	--	----------------------	----------------------------------

SERVICE CONDITION	SL. No. +	LOAD	FLOW (T/HR)	INLET PR. KG/CM2(A)	OUTLET PR. KG/CM2(A)	TEMP DEG (C)	CALC ULATED CV	% VLV LIFT	VLV O/L VELOCITY	
		1.	MAX.-1	10	35	0.2	46.3			
		2.	MAX.-2	10	27	0.5	46.4			
VALVE TYPE							<input checked="" type="checkbox"/> CAVITATION <input type="checkbox"/> FLASHING <input checked="" type="checkbox"/> HIGH DP			
MAX SHUT OFF PRESS (KG/CM2g) 45 BODY DESIGN : PRESS (KG/CM2g) TEMP (DEG C) 45/VACUUM 60 IBR FORM III-C <input type="checkbox"/> REQUIRED <input checked="" type="checkbox"/> NOT REQUIRED									
TOTAL WEIGHT (VALVE + ACTUATOR + ACCESSORIES) Kg									

--

BHEL PEM	DATA SHEET FOR CONTROL VALVES (WITH PNEUMATIC ACTUATOR) 2 X 660 MW ENNORE STPP		SPECIFICATION NO.: PE-TS-412-145-1104			
			VOLUME	IIB		
			SECTION	D		
			REV. NO.	01	DATE :	03.09.15
			SHEET	74	OF	135
Tag No. :...CDV-72... Qty.: ...1 per Unit ... Date Sheet No. PES-145-06-DS1-0 KKS No. LCA33AA101 <p style="text-align: center;">DATA SHEET – A & B</p>						
DATA SHEET – A FOR CONTROL VALVE (WITH PNEUMATIC ACTUATOR) (TO BE FILLED BY PURCHASER)			DATA SHEET – B (TO BE FILLED UP BY BIDDER)			
GENERAL	PROJECT SERVICE LOCATION DUTY PIPE SIZE (inlet / outlet) PIPE MATERIAL (inlet / outlet)	TANGEDCO - 2x660 MW ENNORE STPP CONDENSATE FOR VALVE GLAND SEALING <input checked="" type="checkbox"/> INDOOR <input type="checkbox"/> OUTDOOR <input type="checkbox"/> ON/OFF <input checked="" type="checkbox"/> MODULATING 60.3 x 5.54 60.3 x 5.54 SA 106 GR B SA 106 GR B			
BODY	MODEL NO. TYPE OF BODY: GUIDING : NO. OF PORTS BODY SIZE: PORT SIZE: DESIGN CV END CONNECTION & RATING (ANSI) BODY MATERIAL PACKING: MATERIAL SINGLE / DOUBLE BONNET TYPE TRIM FORM TRIM MATERIAL: SEAT PLUG : CAGE GUIDE BUSH FLOW OUTLET VELOCITY REQUIRED LEAKAGE CLASS NOISE LEVEL (dBA) (at 1 meter) VACUUM SERVICE ANTI CAVITATION TRIM	BIDDER TO INDICATE <input checked="" type="checkbox"/> GLOBE <input type="checkbox"/> ANGLE <input type="checkbox"/> TOP <input checked="" type="checkbox"/> CAGE ONE BIDDER TO INDICATE <input checked="" type="checkbox"/> BWE <input type="checkbox"/> SWE <input type="checkbox"/> FLANGED <input checked="" type="checkbox"/> A216 WCB <input type="checkbox"/> A217 WC6 <input type="checkbox"/> SS <input type="checkbox"/> A217 CS <input type="checkbox"/> A351 CF8M <input type="checkbox"/> PTFE <input checked="" type="checkbox"/> GRAFOIL <input type="checkbox"/> DOUBLE <input checked="" type="checkbox"/> SINGLE BIDDER TO INDICATE <input type="checkbox"/> LINEAR <input checked="" type="checkbox"/> EQ. PERCENTAGE <input type="checkbox"/> QUICK OPEN (ON/OFF) 17-4 PH SS 17-4 PH SS 17-4 PH SS 17-4 PH SS BIDDER TO INDICATE <input checked="" type="checkbox"/> < 7 M/SEC (WATER) <input type="checkbox"/> MAC NO. < 1/3(STM) <input type="checkbox"/> II <input type="checkbox"/> III <input checked="" type="checkbox"/> IV <input type="checkbox"/> V <input type="checkbox"/> VI LESS THAN 85 dBA <input type="checkbox"/> YES <input checked="" type="checkbox"/> NO <input type="checkbox"/> YES <input checked="" type="checkbox"/> NO			
PNEUMATIC ACTUATOR	MODEL NO. & SIZE CLOSE AT : OPEN AT (KG/CM2g) TRAVEL TIME FOR OPEN TO CLOSE, CLOSE TO OPEN VALVE POSN. ON SIGNAL AIR FAILURE VALVE POSN. ON SUPPLY AIR FAILURE	BIDDER TO INDICATE TO SUIT ACTUATOR <10 SEC <input checked="" type="checkbox"/> TO OPEN <input type="checkbox"/> STAYPUT <input type="checkbox"/> TO CLOSE <input checked="" type="checkbox"/> STAYPUT			
ACCESSORIES	POSITIONER (SMART) AIR FILTER REGULATOR AIR LOCK RELAY POSITION LIMIT SWITCH POSITION TRANSMITTER SOLENOID VALVE E/P CONVERTER JUNCTION BOX HAND WHEEL (SIDE MOUNTED) LOCAL POSITION INDICATOR ELECTRO PNEUMATIC POSITIONER MOISTURE SEPARATOR	<input checked="" type="checkbox"/> REQUIRED <input type="checkbox"/> NOT REQUIRED <input checked="" type="checkbox"/> REQUIRED <input type="checkbox"/> NOT REQUIRED <input checked="" type="checkbox"/> REQUIRED <input type="checkbox"/> NOT REQUIRED <input checked="" type="checkbox"/> REQUIRED <input type="checkbox"/> NOT REQUIRED PART OF POSITIONER <input checked="" type="checkbox"/> REQUIRED <input type="checkbox"/> NOT REQUIRED PART OF POSITIONER <input checked="" type="checkbox"/> REQUIRED <input type="checkbox"/> NOT REQUIRED <input checked="" type="checkbox"/> REQUIRED <input type="checkbox"/> NOT REQUIRED <input checked="" type="checkbox"/> REQUIRED <input checked="" type="checkbox"/> REQUIRED <input type="checkbox"/> REQUIRED <input checked="" type="checkbox"/> NOT REQUIRED <input checked="" type="checkbox"/> REQUIRED			

BHEL PEM	DATA SHEET FOR CONTROL VALVES (WITH PNEUMATIC ACTUATOR) 2 X 660 MW ENNORE STPP		SPECIFICATION NO.: PE-TS-412-145-1104			
			VOLUME IIB			
			SECTION D			
			REV. NO.	01	DATE : 03.09.15	
			SHEET		79	OF 135

Tag No. :...DRV-5... Qty.: ...1 per Unit ...
KKS No. LCH35AA101

Date Sheet No. PES-145-06-DS1-0

DATA SHEET – A & B

DATA SHEET – A FOR CONTROL VALVE (WITH PNEUMATIC ACTUATOR) (TO BE FILLED BY PURCHASER)	DATA SHEET – B (TO BE FILLED UP BY BIDDER)
---	---

PERFORMANCE OF VALVE	LINEARITY HYSTERISIS SENSITIVITY ACCURACY (OVERALL)	± 1% ± 1% ± 0.5% ± 1%
----------------------	--	--------------------------------	----------------------------------

SERVICE CONDITION	SL. No. +	LOAD	FLOW (T/HR)	INLET PR. KG/CM2(A)	OUTLET PR. KG/CM2(A)	TEMP DEG (C)	CALC ULATED CV	% VLV LIFT	VLV O/L VELOCITY
	1.	40% MCR	72.5	23.3	0.3	217.1			
	2.	60% MCR	131.0	33.7	0.3	238.0			
	3.	100% MCR	297.1	54.5	0.3	267.9			
	4.	VWO	329.6	58.1	0.3	272.1			
VALVE TYPE							<input type="checkbox"/> CAVITATION <input checked="" type="checkbox"/> FLASHING <input type="checkbox"/> HIGH DP		
MAX SHUT OFF PRESS (KG/CM2g) 73.1 BODY DESIGN : PRESS (KG/CM2g) TEMP (DEG C) 73.1/VACUUM 275 IBR FORM III-C <input type="checkbox"/> REQUIRED <input checked="" type="checkbox"/> NOT REQUIRED								
TOTAL WEIGHT (VALVE + ACTUATOR + ACCESSORIES) Kg								

--	--

BHEL PEM	DATA SHEET FOR CONTROL VALVES (WITH PNEUMATIC ACTUATOR) 2 X 660 MW ENNORE STPP		SPECIFICATION NO.: PE-TS-412-145-I104		
			VOLUME IIB		
			SECTION D		
			REV. NO. 01	DATE : 03.09.15	
			SHEET 81	OF 135	

Tag No. :...DRV-15... Qty.: ...1 per Unit ...
KKS No. LCH10AA101

Date Sheet No. PES-145-06-DS1-0

DATA SHEET – A & B

DATA SHEET – A FOR CONTROL VALVE (WITH PNEUMATIC ACTUATOR) (TO BE FILLED BY PURCHASER)	DATA SHEET – B (TO BE FILLED UP BY BIDDER)
---	---

PERFORMANCE OF VALVE	LINEARITY ± 1% HYSTERISIS ± 1% SENSITIVITY ± 0.5% ACCURACY (OVERALL) ± 1%
----------------------	--	----------------------------------

SERVICE CONDITION	SL. No. +	LOAD	FLOW (T/HR)	INLET PR. KG/CM2(A)	OUTLET PR. KG/CM2(A)	TEMP DEG (C)	CALC ULATED CV	% VLV LIFT	VLV O/L VELOCITY
	1.	40% MCR	98.8	8.5	6.1	160.5			
	2.	60% MCR	173.2	13.1	8.5	174.8			
	3.	100% MCR	377.5	22.2	12.6	196.6			
	4.	VWO	417.0	23.8	13.3	199.4			
VALVE TYPE							<input type="checkbox"/> CAVITATION <input checked="" type="checkbox"/> FLASHING <input type="checkbox"/> HIGH DP		
MAX SHUT OFF PRESS (KG/CM2g) 30 BODY DESIGN : PRESS (KG/CM2g) TEMP (DEG C) 30 210 IBR FORM III-C <input type="checkbox"/> REQUIRED <input checked="" type="checkbox"/> NOT REQUIRED								

TOTAL WEIGHT (VALVE + ACTUATOR + ACCESSORIES) Kg
--	-------

--

BHEL PEM	DATA SHEET FOR CONTROL VALVES (WITH PNEUMATIC ACTUATOR) 2 X 660 MW ENNORE STPP		SPECIFICATION NO.: PE-TS-412-145-1104	
			VOLUME	IIB
			SECTION	D
			REV. NO.	01 DATE : 03.09.15
			SHEET	82 OF 135
Tag No. :...DRV-18... Qty.: ...1 per Unit ... KKS No. LCH15AA101			Date Sheet No. PES-145-06-DS1-0	
DATA SHEET – A & B				
DATA SHEET – A FOR CONTROL VALVE (WITH PNEUMATIC ACTUATOR) (TO BE FILLED BY PURCHASER)				DATA SHEET – B (TO BE FILLED UP BY BIDDER)
GENERAL	PROJECT	TANGEDCO - 2x660 MW ENNORE STPP	
	SERVICE	HPH-6 ALT. DRAIN TO F/T	
GENERAL	LOCATION	<input checked="" type="checkbox"/> INDOOR <input type="checkbox"/> OUTDOOR	
	DUTY	<input type="checkbox"/> ON/OFF <input checked="" type="checkbox"/> MODULATING	
GENERAL	PIPE SIZE (inlet / outlet)	323.9 x 9.53 355.6 x 9.53	
	PIPE MATERIAL (inlet / outlet)	SA 106 GR B SA 106 GR B	
BODY	MODEL NO.	BIDDER TO INDICATE	
	TYPE OF BODY: GUIDING : NO. OF PORTS	<input checked="" type="checkbox"/> GLOBE <input type="checkbox"/> ANGLE <input type="checkbox"/> TOP <input checked="" type="checkbox"/> CAGE ONE	
	BODY SIZE: PORT SIZE: DESIGN CV	BIDDER TO INDICATE	
	END CONNECTION & RATING (ANSI)	<input checked="" type="checkbox"/> BWE <input type="checkbox"/> SWE <input type="checkbox"/> FLANGED	
	BODY MATERIAL	<input type="checkbox"/> A216 WCB <input checked="" type="checkbox"/> A217 WC9 <input type="checkbox"/> SS <input type="checkbox"/> A217 CS <input type="checkbox"/> A351 CF8M	
	PACKING: MATERIAL SINGLE / DOUBLE	<input type="checkbox"/> PTFE <input checked="" type="checkbox"/> GRAFOIL <input checked="" type="checkbox"/> DOUBLE <input type="checkbox"/> SINGLE	
	BONNET TYPE	BIDDER TO INDICATE	
	TRIM FORM	<input checked="" type="checkbox"/> LINEAR <input type="checkbox"/> EQ. PERCENTAGE <input type="checkbox"/> QUICK OPEN (ON/OFF)	
	TRIM MATERIAL: SEAT PLUG	440 C 440 C	
	: CAGE GUIDE BUSH	440 C 440 C	
BODY	FLOW	BIDDER TO INDICATE	
	OUTLET VELOCITY	<input checked="" type="checkbox"/> < 7 M/SEC (WATER) <input type="checkbox"/> MAC NO. < 1/3(STM)	
	REQUIRED LEAKAGE CLASS	<input type="checkbox"/> II <input type="checkbox"/> III <input type="checkbox"/> IV <input checked="" type="checkbox"/> V <input type="checkbox"/> VI	
	NOISE LEVEL (dBA) (at 1 meter)	LESS THAN 85 dBA	
	VACUUM SERVICE	<input checked="" type="checkbox"/> YES <input type="checkbox"/> NO	
	ANTI CAVITATION TRIM	<input checked="" type="checkbox"/> YES <input type="checkbox"/> NO	
PNEUMATIC ACTUATOR	MODEL NO. & SIZE	BIDDER TO INDICATE	
	CLOSE AT : OPEN AT (KG/CM2g)	TO SUIT ACTUATOR	
	TRAVEL TIME FOR OPEN TO CLOSE, CLOSE TO OPEN	<10 SEC	
	VALVE POSN. ON SIGNAL AIR FAILURE	<input checked="" type="checkbox"/> TO OPEN <input type="checkbox"/> STAYPUT <input type="checkbox"/> TO CLOSE	
PNEUMATIC ACTUATOR	VALVE POSN. ON SUPPLY AIR FAILURE	<input checked="" type="checkbox"/> TO OPEN	
ACCESSORIES	POSITIONER (SMART)	<input checked="" type="checkbox"/> REQUIRED <input type="checkbox"/> NOT REQUIRED	
	AIR FILTER REGULATOR	<input checked="" type="checkbox"/> REQUIRED <input type="checkbox"/> NOT REQUIRED	
	AIR LOCK RELAY	<input checked="" type="checkbox"/> REQUIRED <input type="checkbox"/> NOT REQUIRED	
	POSITION LIMIT SWITCH	<input checked="" type="checkbox"/> REQUIRED <input type="checkbox"/> NOT REQUIRED	
	POSITION TRANSMITTER	PART OF POSITIONER	
	SOLENOID VALVE	<input checked="" type="checkbox"/> REQUIRED <input type="checkbox"/> NOT REQUIRED	
	E/P CONVERTER	PART OF POSITIONER	
	JUNCTION BOX	<input checked="" type="checkbox"/> REQUIRED <input type="checkbox"/> NOT REQUIRED	
	HAND WHEEL (SIDE MOUNTED)	<input checked="" type="checkbox"/> REQUIRED	
	LOCAL POSITION INDICATOR	<input checked="" type="checkbox"/> REQUIRED	
	ELECTRO PNEUMATIC POSITIONER	<input type="checkbox"/> REQUIRED <input checked="" type="checkbox"/> NOT REQUIRED	
	MOISTURE SEPARATOR	<input checked="" type="checkbox"/> REQUIRED	

BHEL PEM	DATA SHEET FOR CONTROL VALVES (WITH PNEUMATIC ACTUATOR) 2 X 660 MW ENNORE STPP	SPECIFICATION NO.: PE-TS-412-145-1104	
		VOLUME	IIB
		SECTION	D
		REV. NO.	01
		SHEET	83 OF 135

Tag No. :...DRV-18... Qty.: ...1 per Unit ...
KKS No. LCH15AA101

Date Sheet No. PES-145-06-DS1-0

DATA SHEET – A & B

DATA SHEET – A FOR CONTROL VALVE (WITH PNEUMATIC ACTUATOR) (TO BE FILLED BY PURCHASER)	DATA SHEET – B (TO BE FILLED UP BY BIDDER)
---	---

PERFORMANCE OF VALVE	LINEARITY ± 1% HYSTERISIS ± 1% SENSITIVITY ± 0.5% ACCURACY (OVERALL) ± 1%
----------------------	--	----------------------------------

SERVICE CONDITION	SL. No. +	LOAD	FLOW (T/HR)	INLET PR. KG/CM2(A)	OUTLET PR. KG/CM2(A)	TEMP DEG (C)	CALC ULATED CV	% VLV LIFT	VLV O/L VELOCITY
	1.	40% MCR	98.8	10.3	0.3	179.5			
	2.	60% MCR	173.2	14.9	0.3	196.8			
	3.	100% MCR	377.5	23.9	0.3	221.3			
	4.	VWO	417.0	25.5	0.3	224.7			
VALVE TYPE							<input type="checkbox"/> CAVITATION <input checked="" type="checkbox"/> FLASHING <input type="checkbox"/> HIGH DP		
MAX SHUT OFF PRESS (KG/CM2g) 30 BODY DESIGN : PRESS (KG/CM2g) TEMP (DEG C) 30/VACUUM 230 IBR FORM III-C <input type="checkbox"/> REQUIRED <input checked="" type="checkbox"/> NOT REQUIRED								
TOTAL WEIGHT (VALVE + ACTUATOR + ACCESSORIES) Kg								

--	--

BHEL PEM	DATA SHEET FOR CONTROL VALVES (WITH PNEUMATIC ACTUATOR) 2 X 660 MW ENNORE STPP		SPECIFICATION NO.: PE-TS-412-145-1104			
			VOLUME	IIB		
			SECTION	D		
			REV. NO.	01	DATE :	03.09.15
			SHEET	84	OF	135
Tag No. :...DRV-28... Qty.: ...1 per Unit ...		Date Sheet No. PES-145-06-DS1-0				
KKS No. LCJ30AA101		DATA SHEET – A & B				
DATA SHEET – A FOR CONTROL VALVE (WITH PNEUMATIC ACTUATOR) (TO BE FILLED BY PURCHASER)			DATA SHEET – B (TO BE FILLED UP BY BIDDER)			
GENERAL	PROJECT	TANGEDCO - 2x660 MW ENNORE STPP				
	SERVICE	LPH-3 NORMAL DRAIN TO LPH-2				
LOCATION	DUTY	<input checked="" type="checkbox"/> INDOOR <input type="checkbox"/> OUTDOOR				
	PIPE SIZE (inlet / outlet)	<input type="checkbox"/> ON/OFF <input checked="" type="checkbox"/> MODULATING				
PIPE MATERIAL (inlet / outlet)	PIPE SIZE (inlet / outlet)	273 x 6.35 323.9 x 9.53				
	PIPE MATERIAL (inlet / outlet)	SA 106 GR B SA 106 GR B				
BODY	MODEL NO.	BIDDER TO INDICATE				
	TYPE OF BODY: GUIDING : NO. OF PORTS	<input checked="" type="checkbox"/> GLOBE <input type="checkbox"/> ANGLE <input type="checkbox"/> TOP <input checked="" type="checkbox"/> CAGE ONE				
BODY MATERIAL	BODY SIZE: PORT SIZE: DESIGN CV	BIDDER TO INDICATE				
	END CONNECTION & RATING (ANSI)	<input checked="" type="checkbox"/> BWE <input type="checkbox"/> SWE <input type="checkbox"/> FLANGED				
PACKING: MATERIAL SINGLE / DOUBLE	BODY MATERIAL	<input type="checkbox"/> A216 WCB <input checked="" type="checkbox"/> A217 WC6 <input type="checkbox"/> SS <input type="checkbox"/> A217 CS				
	BONNET TYPE	<input type="checkbox"/> A351 CF8M				
TRIM FORM	TRIM MATERIAL: SEAT PLUG	<input type="checkbox"/> PTFE <input checked="" type="checkbox"/> GRAFOIL <input checked="" type="checkbox"/> DOUBLE <input type="checkbox"/> SINGLE				
	: CAGE GUIDE BUSH	BIDDER TO INDICATE				
FLOW	OUTLET VELOCITY	<input checked="" type="checkbox"/> LINEAR <input type="checkbox"/> EQ. PERCENTAGE				
	REQUIRED LEAKAGE CLASS	<input type="checkbox"/> QUICK OPEN (ON/OFF)				
NOISE LEVEL (dBA) (at 1 meter)	VACUUM SERVICE	17-4 PH SS 17-4 PH SS				
	ANTI CAVITATION TRIM	17-4 PH SS 17-4 PH SS				
PNEUMATIC ACTUATOR	MODEL NO. & SIZE	BIDDER TO INDICATE				
	CLOSE AT : OPEN AT (KG/CM2g)	TO SUIT ACTUATOR				
VALVE POSN. ON SIGNAL AIR FAILURE	TRAVEL TIME FOR	<10 SEC				
	OPEN TO CLOSE, CLOSE TO OPEN	<input type="checkbox"/> TO OPEN <input type="checkbox"/> STAYPUT <input checked="" type="checkbox"/> TO CLOSE				
ACCESSORIES	VALVE POSN. ON SUPPLY AIR FAILURE	<input checked="" type="checkbox"/> TO CLOSE				
	POSITIONER (SMART)	<input checked="" type="checkbox"/> REQUIRED <input type="checkbox"/> NOT REQUIRED				
AIR FILTER REGULATOR	AIR FILTER REGULATOR	<input checked="" type="checkbox"/> REQUIRED <input type="checkbox"/> NOT REQUIRED				
	AIR LOCK RELAY	<input checked="" type="checkbox"/> REQUIRED <input type="checkbox"/> NOT REQUIRED				
POSITION LIMIT SWITCH	POSITION LIMIT SWITCH	<input checked="" type="checkbox"/> REQUIRED <input type="checkbox"/> NOT REQUIRED				
	POSITION TRANSMITTER	PART OF POSITIONER				
SOLENOID VALVE	SOLENOID VALVE	<input checked="" type="checkbox"/> REQUIRED <input type="checkbox"/> NOT REQUIRED				
	E/P CONVERTER	PART OF POSITIONER				
JUNCTION BOX	JUNCTION BOX	<input checked="" type="checkbox"/> REQUIRED <input type="checkbox"/> NOT REQUIRED				
	HAND WHEEL (SIDE MOUNTED)	<input checked="" type="checkbox"/> REQUIRED				
LOCAL POSITION INDICATOR	LOCAL POSITION INDICATOR	<input checked="" type="checkbox"/> REQUIRED				
	ELECTRO PNEUMATIC POSITIONER	<input type="checkbox"/> REQUIRED <input checked="" type="checkbox"/> NOT REQUIRED				
MOISTURE SEPARATOR	MOISTURE SEPARATOR	<input checked="" type="checkbox"/> REQUIRED				

BHEL PEM	DATA SHEET FOR CONTROL VALVES (WITH PNEUMATIC ACTUATOR) 2 X 660 MW ENNORE STPP			SPECIFICATION NO.: PE-TS-412-145-1104		
				VOLUME IIB		
				SECTION D		
				REV. NO.	01	DATE : 03.09.15
				SHEET	91	OF 135

Tag No. :...DRV-37... Qty.: ...1 per Unit ...
KKS No. LCJ21AA101

Date Sheet No. PES-145-06-DS1-0

DATA SHEET – A & B

DATA SHEET – A FOR CONTROL VALVE (WITH PNEUMATIC ACTUATOR) (TO BE FILLED BY PURCHASER)				DATA SHEET – B (TO BE FILLED UP BY BIDDER)	
PERFORMANCE OF VALVE	LINEARITY	$\pm 1\%$
	HYSTERESIS	$\pm 1\%$
	SENSITIVITY	$\pm 0.5\%$
	ACCURACY (OVERALL)	$\pm 1\%$

SERVICE CONDITION	SL. No. +	LOAD	FLOW (T/HR)	INLET PR. KG/CM2(A)	OUTLET PR. KG/CM2(A)	TEMP DEG (C)	CALC ULATED CV	% VLV LIFT	VLV O/L VELOCITY
	1.	40% MCR	65.6	0.9	0.3	76.0			
	2.	60% MCR	106.1	1.0	0.3	84.9			
	3.	100% MCR	200.5	1.2	0.3	96.5			
	4.	VWO	218.2	1.3	0.3	98.1			
VALVE TYPE							<input checked="" type="checkbox"/> CAVITATION <input checked="" type="checkbox"/> FLASHING <input type="checkbox"/> HIGH DP		
MAX SHUT OFF PRESS (KG/CM2g) 3.5 BODY DESIGN : PRESS (KG/CM2g) TEMP (DEG C) 3.5/VACUUM 105 IBR FORM III-C <input type="checkbox"/> REQUIRED <input checked="" type="checkbox"/> NOT REQUIRED								
TOTAL WEIGHT (VALVE + ACTUATOR + ACCESSORIES) Kg								

BHEL PEM	DATA SHEET FOR CONTROL VALVES (WITH PNEUMATIC ACTUATOR) 2 X 660 MW ENNORE STPP		SPECIFICATION NO.: PE-TS-412-145-I104			
			VOLUME	IIB		
			SECTION	D		
			REV. NO.	01	DATE :	03.09.15
			SHEET	92	OF	135
Tag No. :...DRV-48... Qty.: ...1 per Unit ... KKS No. LAA01AA201		Date Sheet No. PES-145-06-DS1-0				
DATA SHEET – A & B						
DATA SHEET – A FOR CONTROL VALVE (WITH PNEUMATIC ACTUATOR) (TO BE FILLED BY PURCHASER)			DATA SHEET – B (TO BE FILLED UP BY BIDDER)			
GENERAL	PROJECT	TANGEDCO - 2x660 MW ENNORE STPP			
	SERVICE	DEAERATOR OVERFLOW TO F/T			
GENERAL	LOCATION	<input checked="" type="checkbox"/> INDOOR <input type="checkbox"/> OUTDOOR			
	DUTY	<input checked="" type="checkbox"/> ON/OFF <input type="checkbox"/> MODULATING			
GENERAL	PIPE SIZE (inlet / outlet)	219.1 x 6.35	323.9 x 9.53		
	PIPE MATERIAL (inlet / outlet)	SA 106 GR B	SA 106 GR B		
BODY	MODEL NO.	BIDDER TO INDICATE			
	TYPE OF BODY: GUIDING : NO. OF PORTS	<input checked="" type="checkbox"/> GLOBE <input type="checkbox"/> ANGLE <input type="checkbox"/> TOP <input checked="" type="checkbox"/> CAGE ONE			
	BODY SIZE: PORT SIZE: DESIGN CV	BIDDER TO INDICATE			
	END CONNECTION & RATING (ANSI)	<input checked="" type="checkbox"/> BWE <input type="checkbox"/> SWE <input type="checkbox"/> FLANGED			
	BODY MATERIAL	<input type="checkbox"/> A216 WCB <input checked="" type="checkbox"/> A217 WC9 <input type="checkbox"/> SS <input type="checkbox"/> A217 CS <input type="checkbox"/> A351 CF8M			
	PACKING: MATERIAL SINGLE / DOUBLE	<input type="checkbox"/> PTFE <input checked="" type="checkbox"/> GRAFOIL <input checked="" type="checkbox"/> DOUBLE <input type="checkbox"/> SINGLE			
	BONNET TYPE	BIDDER TO INDICATE			
	TRIM FORM	<input type="checkbox"/> LINEAR <input type="checkbox"/> EQ. PERCENTAGE <input checked="" type="checkbox"/> QUICK OPEN (ON/OFF)			
	TRIM MATERIAL: SEAT PLUG	440 C	440 C		
	: CAGE GUIDE BUSH	440 C	440 C		
FLOW	BIDDER TO INDICATE				
OUTLET VELOCITY	<input checked="" type="checkbox"/> < 7 M/SEC (WATER) <input type="checkbox"/> MAC NO. < 1/3(STM)				
REQUIRED LEAKAGE CLASS	<input type="checkbox"/> II <input type="checkbox"/> III <input type="checkbox"/> IV <input checked="" type="checkbox"/> V <input type="checkbox"/> VI				
NOISE LEVEL (dBA) (at 1 meter)	LESS THAN 85 dBA				
VACUUM SERVICE	<input checked="" type="checkbox"/> YES <input type="checkbox"/> NO				
ANTI CAVITATION TRIM	<input type="checkbox"/> YES <input checked="" type="checkbox"/> NO				
PNEUMATIC ACTUATOR	MODEL NO. & SIZE	BIDDER TO INDICATE			
	CLOSE AT : OPEN AT (KG/CM2g)	TO SUIT ACTUATOR			
	TRAVEL TIME FOR OPEN TO CLOSE, CLOSE TO OPEN	<10 SEC			
	VALVE POSN. ON SIGNAL AIR FAILURE	<input checked="" type="checkbox"/> TO OPEN <input type="checkbox"/> STAYPUT <input type="checkbox"/> TO CLOSE			
VALVE POSN. ON SUPPLY AIR FAILURE	<input checked="" type="checkbox"/> STAYPUT				
ACCESSORIES	POSITIONER (SMART)	<input type="checkbox"/> REQUIRED <input checked="" type="checkbox"/> NOT REQUIRED			
	AIR FILTER REGULATOR	<input checked="" type="checkbox"/> REQUIRED <input type="checkbox"/> NOT REQUIRED			
	AIR LOCK RELAY	<input checked="" type="checkbox"/> REQUIRED <input type="checkbox"/> NOT REQUIRED			
	POSITION LIMIT SWITCH	<input checked="" type="checkbox"/> REQUIRED <input type="checkbox"/> NOT REQUIRED			
	POSITION TRANSMITTER	<input type="checkbox"/> REQUIRED <input checked="" type="checkbox"/> NOT REQUIRED			
	SOLENOID VALVE	<input checked="" type="checkbox"/> REQUIRED <input type="checkbox"/> NOT REQUIRED			
	E/P CONVERTER	<input type="checkbox"/> REQUIRED <input checked="" type="checkbox"/> NOT REQUIRED			
	JUNCTION BOX	<input checked="" type="checkbox"/> REQUIRED <input type="checkbox"/> NOT REQUIRED			
	HAND WHEEL (SIDE MOUNTED)	<input checked="" type="checkbox"/> REQUIRED			
	LOCAL POSITION INDICATOR	<input checked="" type="checkbox"/> REQUIRED			
	ELECTRO PNEUMATIC POSITIONER	<input type="checkbox"/> REQUIRED <input checked="" type="checkbox"/> NOT REQUIRED			
	MOISTURE SEPARATOR	<input checked="" type="checkbox"/> REQUIRED			

BHEL PEM	DATA SHEET FOR CONTROL VALVES (WITH PNEUMATIC ACTUATOR) 2 X 660 MW ENNORE STPP	SPECIFICATION NO.: PE-TS-412-145-1104		
		VOLUME	IIB	
		SECTION	D	
		REV. NO.	01	DATE : 03.09.15
		SHEET	94	OF 135

Tag No. :...DRV-53... Qty.: ...1 per Unit ...
KKS No. LCH50AA101

Date Sheet No. PES-145-06-DS1-0

DATA SHEET – A & B

DATA SHEET – A FOR CONTROL VALVE (WITH PNEUMATIC ACTUATOR) (TO BE FILLED BY PURCHASER)		DATA SHEET – B (TO BE FILLED UP BY BIDDER)
GENERAL	PROJECT SERVICE LOCATION DUTY PIPE SIZE (inlet / outlet) PIPE MATERIAL (inlet / outlet)	TANGEDCO - 2x660 MW ENNORE STPP HPH-8 NORMAL DRAIN TO HPH-7 <input checked="" type="checkbox"/> INDOOR <input type="checkbox"/> OUTDOOR <input type="checkbox"/> ON/OFF <input checked="" type="checkbox"/> MODULATING 219.1 x 10.31 219.1 x 10.31 SA 106 GR C SA 106 GR C
BODY	MODEL NO. TYPE OF BODY: GUIDING : NO. OF PORTS BODY SIZE: PORT SIZE: DESIGN CV END CONNECTION & RATING (ANSI) BODY MATERIAL PACKING: MATERIAL SINGLE / DOUBLE BONNET TYPE TRIM FORM TRIM MATERIAL: SEAT PLUG : CAGE GUIDE BUSH FLOW OUTLET VELOCITY REQUIRED LEAKAGE CLASS NOISE LEVEL (dBA) (at 1 meter) VACUUM SERVICE ANTI CAVITATION TRIM	BIDDER TO INDICATE <input checked="" type="checkbox"/> GLOBE <input type="checkbox"/> ANGLE <input type="checkbox"/> TOP <input checked="" type="checkbox"/> CAGE ONE BIDDER TO INDICATE <input checked="" type="checkbox"/> BWE <input type="checkbox"/> SWE <input type="checkbox"/> FLANGED <input type="checkbox"/> A216 WCB <input checked="" type="checkbox"/> A217 WC9 <input type="checkbox"/> SS <input type="checkbox"/> A217 CS <input type="checkbox"/> A351 CF8M <input type="checkbox"/> PTFE <input checked="" type="checkbox"/> GRAFOIL <input type="checkbox"/> DOUBLE <input checked="" type="checkbox"/> SINGLE BIDDER TO INDICATE <input checked="" type="checkbox"/> LINEAR <input type="checkbox"/> EQ. PERCENTAGE <input type="checkbox"/> QUICK OPEN (ON/OFF) 17-4 PH SS 17-4 PH SS 17-4 PH SS 17-4 PH SS BIDDER TO INDICATE <input checked="" type="checkbox"/> < 7 M/SEC (WATER) <input type="checkbox"/> MAC NO. < 1/3(STM) <input type="checkbox"/> II <input type="checkbox"/> III <input checked="" type="checkbox"/> IV <input type="checkbox"/> V <input type="checkbox"/> VI LESS THAN 85 dBA <input type="checkbox"/> YES <input checked="" type="checkbox"/> NO <input type="checkbox"/> YES <input checked="" type="checkbox"/> NO
PNEUMATIC ACTUATOR	MODEL NO. & SIZE CLOSE AT : OPEN AT (KG/CM2g) TRAVEL TIME FOR OPEN TO CLOSE, CLOSE TO OPEN VALVE POSN. ON SIGNAL AIR FAILURE VALVE POSN. ON SUPPLY AIR FAILURE	BIDDER TO INDICATE TO SUIT ACTUATOR <10 SEC <input type="checkbox"/> TO OPEN <input type="checkbox"/> STAYPUT <input checked="" type="checkbox"/> TO CLOSE <input checked="" type="checkbox"/> TO CLOSE
ACCESSORIES	POSITIONER (SMART) AIR FILTER REGULATOR AIR LOCK RELAY POSITION LIMIT SWITCH POSITION TRANSMITTER SOLENOID VALVE E/P CONVERTER JUNCTION BOX HAND WHEEL (SIDE MOUNTED) LOCAL POSITION INDICATOR ELECTRO PNEUMATIC POSITIONER MOISTURE SEPARATOR	<input checked="" type="checkbox"/> REQUIRED <input type="checkbox"/> NOT REQUIRED <input checked="" type="checkbox"/> REQUIRED <input type="checkbox"/> NOT REQUIRED <input checked="" type="checkbox"/> REQUIRED <input type="checkbox"/> NOT REQUIRED <input checked="" type="checkbox"/> REQUIRED <input type="checkbox"/> NOT REQUIRED PART OF POSITIONER <input checked="" type="checkbox"/> REQUIRED <input type="checkbox"/> NOT REQUIRED PART OF POSITIONER <input checked="" type="checkbox"/> REQUIRED <input type="checkbox"/> NOT REQUIRED <input checked="" type="checkbox"/> REQUIRED <input checked="" type="checkbox"/> REQUIRED <input type="checkbox"/> REQUIRED <input checked="" type="checkbox"/> NOT REQUIRED <input checked="" type="checkbox"/> REQUIRED

BHEL PEM	DATA SHEET FOR CONTROL VALVES (WITH PNEUMATIC ACTUATOR) 2 X 660 MW ENNORE STPP		SPECIFICATION NO.: PE-TS-412-145-1104			
			VOLUME	IIB		
			SECTION	D		
			REV. NO.	01	DATE :	03.09.15
			SHEET	96	OF	135
Tag No. :...DRV-59... Qty.: ...1 per Unit ... KKS No. LCH55AA101		Date Sheet No. PES-145-06-DS1-0				
DATA SHEET – A & B						
DATA SHEET – A FOR CONTROL VALVE (WITH PNEUMATIC ACTUATOR) (TO BE FILLED BY PURCHASER)			DATA SHEET – B (TO BE FILLED UP BY BIDDER)			
GENERAL	PROJECT SERVICE	TANGEDCO - 2x660 MW ENNORE STPP			
	LOCATION	HPH-8 ALT. DRAIN TO F/T			
GENERAL	DUTY	<input checked="" type="checkbox"/> INDOOR <input type="checkbox"/> OUTDOOR			
	PIPE SIZE (inlet / outlet)	<input type="checkbox"/> ON/OFF <input checked="" type="checkbox"/> MODULATING			
GENERAL	PIPE MATERIAL (inlet / outlet)	219.1 x 10.31 273 x 12.7			
		SA 106 GR C SA 106 GR C			
BODY	MODEL NO.	BIDDER TO INDICATE			
	TYPE OF BODY: GUIDING : NO. OF PORTS	<input checked="" type="checkbox"/> GLOBE <input type="checkbox"/> ANGLE <input type="checkbox"/> TOP <input checked="" type="checkbox"/> CAGE ONE			
BODY	BODY SIZE: PORT SIZE: DESIGN CV	BIDDER TO INDICATE			
	END CONNECTION & RATING (ANSI)	<input checked="" type="checkbox"/> BWE <input type="checkbox"/> SWE <input type="checkbox"/> FLANGED			
BODY	BODY MATERIAL	<input type="checkbox"/> A216 WCB <input checked="" type="checkbox"/> A217 WC9 <input type="checkbox"/> SS <input type="checkbox"/> A217 CS			
		<input type="checkbox"/> A351 CF8M			
BODY	PACKING: MATERIAL SINGLE / DOUBLE	<input type="checkbox"/> PTFE <input checked="" type="checkbox"/> GRAFOIL <input checked="" type="checkbox"/> DOUBLE <input type="checkbox"/> SINGLE			
	BONNET TYPE	BIDDER TO INDICATE			
BODY	TRIM FORM	<input checked="" type="checkbox"/> LINEAR <input type="checkbox"/> EQ. PERCENTAGE			
		<input type="checkbox"/> QUICK OPEN (ON/OFF)			
BODY	TRIM MATERIAL: SEAT PLUG	440 C 440 C			
	: CAGE GUIDE BUSH	440 C 440 C			
BODY	FLOW	BIDDER TO INDICATE			
	OUTLET VELOCITY	<input checked="" type="checkbox"/> < 7 M/SEC (WATER) <input type="checkbox"/> MAC NO. < 1/3(STM)			
BODY	REQUIRED LEAKAGE CLASS	<input type="checkbox"/> II <input type="checkbox"/> III <input type="checkbox"/> IV <input checked="" type="checkbox"/> V <input type="checkbox"/> VI			
	NOISE LEVEL (dBA) (at 1 meter)	LESS THAN 85 dBA			
BODY	VACUUM SERVICE	<input checked="" type="checkbox"/> YES <input type="checkbox"/> NO			
	ANTI CAVITATION TRIM	<input checked="" type="checkbox"/> YES <input type="checkbox"/> NO			
PNEUMATIC ACTUATOR	MODEL NO. & SIZE	BIDDER TO INDICATE			
	CLOSE AT : OPEN AT (KG/CM2g)	TO SUIT ACTUATOR			
PNEUMATIC ACTUATOR	TRAVEL TIME FOR	<10 SEC			
	OPEN TO CLOSE, CLOSE TO OPEN				
PNEUMATIC ACTUATOR	VALVE POSN. ON SIGNAL AIR FAILURE	<input checked="" type="checkbox"/> TO OPEN <input type="checkbox"/> STAYPUT <input type="checkbox"/> TO CLOSE			
	VALVE POSN. ON SUPPLY AIR FAILURE	<input checked="" type="checkbox"/> TO OPEN			
ACCESSORIES	POSITIONER (SMART)	<input checked="" type="checkbox"/> REQUIRED <input type="checkbox"/> NOT REQUIRED			
	AIR FILTER REGULATOR	<input checked="" type="checkbox"/> REQUIRED <input type="checkbox"/> NOT REQUIRED			
ACCESSORIES	AIR LOCK RELAY	<input checked="" type="checkbox"/> REQUIRED <input type="checkbox"/> NOT REQUIRED			
	POSITION LIMIT SWITCH	<input checked="" type="checkbox"/> REQUIRED <input type="checkbox"/> NOT REQUIRED			
ACCESSORIES	POSITION TRANSMITTER	PART OF POSITIONER			
	SOLENOID VALVE	<input checked="" type="checkbox"/> REQUIRED <input type="checkbox"/> NOT REQUIRED			
ACCESSORIES	E/P CONVERTER	PART OF POSITIONER			
	JUNCTION BOX	<input checked="" type="checkbox"/> REQUIRED <input type="checkbox"/> NOT REQUIRED			
ACCESSORIES	HAND WHEEL (SIDE MOUNTED)	<input checked="" type="checkbox"/> REQUIRED			
	LOCAL POSITION INDICATOR	<input checked="" type="checkbox"/> REQUIRED			
ACCESSORIES	ELECTRO PNEUMATIC POSITIONER	<input type="checkbox"/> REQUIRED <input checked="" type="checkbox"/> NOT REQUIRED			
	MOISTURE SEPARATOR	<input checked="" type="checkbox"/> REQUIRED			

BHEL PEM	DATA SHEET FOR CONTROL VALVES (WITH PNEUMATIC ACTUATOR) 2 X 660 MW ENNORE STPP	SPECIFICATION NO.: PE-TS-412-145-1104		
		VOLUME	IIB	
		SECTION	D	
		REV. NO.	01	DATE : 03.09.15
		SHEET	98	OF 135

Tag No. :...DRV-65... Qty.: ...1 per Unit ...
KKS No. LCC40AA101

Date Sheet No. PES-145-06-DS1-0

DATA SHEET – A & B

DATA SHEET – A FOR CONTROL VALVE (WITH PNEUMATIC ACTUATOR) (TO BE FILLED BY PURCHASER)		DATA SHEET – B (TO BE FILLED UP BY BIDDER)	
GENERAL	PROJECT SERVICE LOCATION DUTY PIPE SIZE (inlet / outlet) PIPE MATERIAL (inlet / outlet)	TANGEDCO - 2x660 MW ENNORE STPP LPH-4 NORMAL DRAIN TO LPH-3 <input checked="" type="checkbox"/> INDOOR <input type="checkbox"/> OUTDOOR <input type="checkbox"/> ON/OFF <input checked="" type="checkbox"/> MODULATING 168.3 x 7.11 219.1 x 8.18 SA 106 GR B SA 106 GR C
BODY	MODEL NO. TYPE OF BODY: GUIDING : NO. OF PORTS BODY SIZE: PORT SIZE: DESIGN CV END CONNECTION & RATING (ANSI) BODY MATERIAL PACKING: MATERIAL SINGLE / DOUBLE BONNET TYPE TRIM FORM TRIM MATERIAL: SEAT PLUG : CAGE GUIDE BUSH FLOW OUTLET VELOCITY REQUIRED LEAKAGE CLASS NOISE LEVEL (dBA) (at 1 meter) VACUUM SERVICE ANTI CAVITATION TRIM	BIDDER TO INDICATE <input checked="" type="checkbox"/> GLOBE <input type="checkbox"/> ANGLE <input type="checkbox"/> TOP <input checked="" type="checkbox"/> CAGE ONE BIDDER TO INDICATE <input checked="" type="checkbox"/> BWE <input type="checkbox"/> SWE <input type="checkbox"/> FLANGED <input type="checkbox"/> A216 WCB <input checked="" type="checkbox"/> A217 WC6 <input type="checkbox"/> SS <input type="checkbox"/> A217 CS <input type="checkbox"/> A351 CF8M <input type="checkbox"/> PTFE <input checked="" type="checkbox"/> GRAFOIL <input checked="" type="checkbox"/> DOUBLE <input type="checkbox"/> SINGLE BIDDER TO INDICATE <input checked="" type="checkbox"/> LINEAR <input type="checkbox"/> EQ. PERCENTAGE <input type="checkbox"/> QUICK OPEN (ON/OFF) 17-4 PH SS 17-4 PH SS 17-4 PH SS 17-4 PH SS BIDDER TO INDICATE <input checked="" type="checkbox"/> < 7 M/SEC (WATER) <input type="checkbox"/> MAC NO. < 1/3(STM) <input type="checkbox"/> II <input type="checkbox"/> III <input checked="" type="checkbox"/> IV <input type="checkbox"/> V <input type="checkbox"/> VI LESS THAN 85 dBA <input checked="" type="checkbox"/> YES <input type="checkbox"/> NO <input type="checkbox"/> YES <input checked="" type="checkbox"/> NO
PNEUMATIC ACTUATOR	MODEL NO. & SIZE CLOSE AT : OPEN AT (KG/CM2g) TRAVEL TIME FOR OPEN TO CLOSE, CLOSE TO OPEN VALVE POSN. ON SIGNAL AIR FAILURE VALVE POSN. ON SUPPLY AIR FAILURE	BIDDER TO INDICATE TO SUIT ACTUATOR <10 SEC <input type="checkbox"/> TO OPEN <input type="checkbox"/> STAYPUT <input checked="" type="checkbox"/> TO CLOSE <input checked="" type="checkbox"/> TO CLOSE
ACCESSORIES	POSITIONER (SMART) AIR FILTER REGULATOR AIR LOCK RELAY POSITION LIMIT SWITCH POSITION TRANSMITTER SOLENOID VALVE E/P CONVERTER JUNCTION BOX HAND WHEEL (SIDE MOUNTED) LOCAL POSITION INDICATOR ELECTRO PNEUMATIC POSITIONER MOISTURE SEPARATOR	<input checked="" type="checkbox"/> REQUIRED <input type="checkbox"/> NOT REQUIRED <input checked="" type="checkbox"/> REQUIRED <input type="checkbox"/> NOT REQUIRED <input checked="" type="checkbox"/> REQUIRED <input type="checkbox"/> NOT REQUIRED <input checked="" type="checkbox"/> REQUIRED <input type="checkbox"/> NOT REQUIRED PART OF POSITIONER <input checked="" type="checkbox"/> REQUIRED <input type="checkbox"/> NOT REQUIRED PART OF POSITIONER <input checked="" type="checkbox"/> REQUIRED <input type="checkbox"/> NOT REQUIRED <input checked="" type="checkbox"/> REQUIRED <input checked="" type="checkbox"/> REQUIRED <input type="checkbox"/> REQUIRED <input checked="" type="checkbox"/> NOT REQUIRED <input checked="" type="checkbox"/> REQUIRED

BHEL PEM	DATA SHEET FOR CONTROL VALVES (WITH PNEUMATIC ACTUATOR) 2 X 660 MW ENNORE STPP		SPECIFICATION NO.: PE-TS-412-145-1104		
			VOLUME IIB		
			SECTION D		
			REV. NO.	01	DATE : 03.09.15
			SHEET	99	OF 135

Tag No. :...DRV-65... Qty.: ...1 per Unit ...
KKS No. LCC40AA101

Date Sheet No. PES-145-06-DS1-0

DATA SHEET – A & B

DATA SHEET – A FOR CONTROL VALVE (WITH PNEUMATIC ACTUATOR) (TO BE FILLED BY PURCHASER)	DATA SHEET – B (TO BE FILLED UP BY BIDDER)
---	---

PERFORMANCE OF VALVE	LINEARITY HYSTERISIS SENSITIVITY ACCURACY (OVERALL)	± 1% ± 1% ± 0.5% ± 1%
----------------------	--	--------------------------------	----------------------------------

SERVICE CONDITION	SL. No. +	LOAD	FLOW (T/HR)	INLET PR. KG/CM2(A)	OUTLET PR. KG/CM2(A)	TEMP DEG (C)	CALC ULATED CV	% VLV LIFT	VLV O/L VELOCITY
	1.	40% MCR	28.9	2.1	0.6	96.8			
	2.	60% MCR	46.8	3.1	1.1	107.2			
	3.	100% MCR	89.0	4.9	1.8	121.1			
	4.	VWO	96.7	5.1	2.0	123.0			
VALVE TYPE							<input type="checkbox"/> CAVITATION <input checked="" type="checkbox"/> FLASHING <input type="checkbox"/> HIGH DP		
MAX SHUT OFF PRESS (KG/CM2g) 7 BODY DESIGN : PRESS (KG/CM2g) TEMP (DEG C) 7/VACUUM 135 IBR FORM III-C <input type="checkbox"/> REQUIRED <input checked="" type="checkbox"/> NOT REQUIRED								
TOTAL WEIGHT (VALVE + ACTUATOR + ACCESSORIES) Kg								

--

BHEL PEM	DATA SHEET FOR CONTROL VALVES (WITH PNEUMATIC ACTUATOR) 2 X 660 MW ENNORE STPP	SPECIFICATION NO.: PE-TS-412-145-1104	
		VOLUME	IIB
		SECTION	D
		REV. NO.	01 DATE : 03.09.15
		SHEET	103 OF 135

Tag No. :...DMV-40... Qty.: ...1 per Unit ...
KKS No. LCR42AA101

Date Sheet No. PES-145-06-DS1-0

DATA SHEET – A & B

DATA SHEET – A FOR CONTROL VALVE (WITH PNEUMATIC ACTUATOR) (TO BE FILLED BY PURCHASER)	DATA SHEET – B (TO BE FILLED UP BY BIDDER)
---	---

PERFORMANCE OF VALVE	LINEARITY HYSTERISIS SENSITIVITY ACCURACY (OVERALL)	$\pm 1\%$ $\pm 1\%$ $\pm 0.5\%$ $\pm 1\%$
----------------------	--	--	----------------------------------

	SL. No. +	LOAD	FLOW (T/HR)	INLET PR. KG/CM2(A)	OUTLET PR. KG/CM2(A)	TEMP DEG (C)	CALC ULATED CV	% VLV LIFT	VLV O/L VELOCITY	
SERVICE CONDITION	1.	MIN. (0.5% MU)	10.5	7.1	0.5	33				
	2.	NORMAL (1% MU)	21	6.6	0.55	33				
	3.	MAX. (1.5% MU)	31.5	4.1	0.6	33				
	VALVE TYPE							<input checked="" type="checkbox"/> CAVITATION <input type="checkbox"/> FLASHING <input type="checkbox"/> HIGH DP		
	MAX SHUT OFF PRESS (KG/CM2g) 10 BODY DESIGN : PRESS (KG/CM2g) TEMP (DEG C) 10/VACUUM 50 IBR FORM III-C <input type="checkbox"/> REQUIRED <input checked="" type="checkbox"/> NOT REQUIRED								
TOTAL WEIGHT (VALVE + ACTUATOR + ACCESSORIES) Kg									

	<p>Technical specification for Control Valves with Accessories (Pneumatically Operated) 2 X 660 MW ENNORE SEZ STPP</p>	SPECIFICATION NO. PE-TS-412-145-1104	
		VOLUME II-B	
		SECTION D	
		REV. NO. 01	DATE: 03.09.15
		SHEET 108	OF 135

SECTION – D

DATA SHEETS – ACCESSORIES FOR CONTROL VALVES



**DATA SHEET FOR CONTROL VALVES
(WITH PNEUMATIC ACTUATOR)**

2 X 660 MW ENNORE STPP

SPECIFICATION NO. PE-TS-412-145-1104

VOLUME IIB

SECTION D

REV. NO. 01

DATE: 03.09.15

SHEET 109

OF 135

Tag No..... Quantity..... Data Sheet No. PES-145-06-DS1-0

ITEMS SHALL BE APPLICABLE FOR TAG Nos. WHEREVER STATEMENT "REQUIRED" INDICATED IN THE INDIVIDUAL
CV DATA SHEETS

DATA SHEET – A & B for ACCESSORIES

**DATA SHEET – A FOR CONTROL VALVE (WITH PNEUMATIC ACTUATOR)
(TO BE FILLED BY PURCHASER)**

**DATA SHEET – B
(TO BE FILLED-UP BY BIDDER)**

POSITIONER (SMART) ##	MFR. & MODEL NUMBER		BIIDDER TO INDICATE		
	BYPASS	GAUGES	ENCL. CLASS	<input type="checkbox"/> YES <input checked="" type="checkbox"/> NO	<input type="checkbox"/> THREE <input checked="" type="checkbox"/> TWO <input checked="" type="checkbox"/> IP-65
	INPUT SIGNAL (ELECTRICAL)		4-20 mA DC, HART COMPATIBLE		
	OUTPUT SIGNAL (PNEUMATIC)(Kg / Cm ²)		UPTO 10 OR		
	DI FOR FAULT SIGNAL		<input checked="" type="checkbox"/> YES <input type="checkbox"/> NO		
AIR FILTER REGULATOR ##	MFR. & MODEL NUMBER		BIIDDER TO INDICATE		
	AIR SUPPLY PRESS (Kg / Cm ² g)		<input checked="" type="checkbox"/> UPTO 10		
	FILTER SIZE		5 MICRONS		
	OUTPUT PRESS (Kg / Cm ² g)		TO SUIT SMART POSITIONER		
	OUTPUT GAUGE		<input checked="" type="checkbox"/> REQUIRED <input type="checkbox"/> NOT REQUIRED		
AIR LOCK ##	MFR. & MODEL NUMBER		BIIDDER TO INDICATE		
	SET PRESS (Kg / Cm ²)		BIIDDER TO INDICATE		
	SUPPLY PRESS (Kg / Cm ²)		<input checked="" type="checkbox"/> 5.0 - 8.0		
	RESET TYPE		AUTO		
	VENT PLUG		REQUIRED		
LIMIT SWITCH ##	MFR. & MODEL NUMBER		BIIDDER TO INDICATE		
	OPEN posn	INT posn	CLOSE posn	<input checked="" type="checkbox"/> 1 NO.	<input type="checkbox"/> --- <input checked="" type="checkbox"/> 1 NO.
	CONTACT TYPE		SPDT 2 NO + 2 NC		
	RATING (AC / DC)		5A 240V AC AND 0.2A 220V DC		
	ENCLOSURE CLASS		<input checked="" type="checkbox"/> IP 65		
POSITION TRANSMITTER ## (IN BUILT IN SMART POSITIONER)	MFR. & MODEL NUMBER		NOT APPLICABLE		
	TYPE		<input checked="" type="checkbox"/> Electronic (2-Wire Type), Non-Contact Type <input type="checkbox"/> OTHER		
	SUPPLY		<input checked="" type="checkbox"/> 24V DC <input type="checkbox"/> 220V DC <input type="checkbox"/> 110V AC <input type="checkbox"/> 240V AC		
	OUTPUT RATING		<input checked="" type="checkbox"/> 4-20mA <input type="checkbox"/> 0-100 ohms		
	ACCURACY		± 1% FS		
ENCLOSURE CLASS		<input checked="" type="checkbox"/> IP 65			
SOLENOID VALVE ##	MFR. & MODEL NUMBER		BIIDDER TO INDICATE		
	RATING		<input checked="" type="checkbox"/> 24V DC <input type="checkbox"/> 220V DC <input type="checkbox"/> 240V AC <input type="checkbox"/>		
	OPERATION	QUANTITY		<input type="checkbox"/> Stayput <input checked="" type="checkbox"/> Interlock	AS PER DATASHEET & HOOK UP
	COIL INSULATION CLASS		CLASS - H		
	ENCLOSURE CLASS		<input checked="" type="checkbox"/> IP 65		
HANDWHEEL ##	ORIENTATION		<input type="checkbox"/> TOP MOUNTED <input checked="" type="checkbox"/> SIDE MOUNTED		
JUNCTION BOX ##	NO. OF WAYS		<input type="checkbox"/> 24-WAYS <input checked="" type="checkbox"/> 36-Ways <input type="checkbox"/> AS REQUIRED		
	SIZE		AS REQUIRED		
	CABLE GLANDS (Size / Quantity)		AS REQUIRED (Double Compression Type).		
	ENCLOSURE CLASS		<input checked="" type="checkbox"/> IP 65		
I/P CONVERTER ##	MFR. & MODEL NUMBER		IN BUILT IN SMART POSITIONER		
	INPUT SIGNAL	POWER SUPPLY			
	SPLIT RANGE				
	ENCLOSURE CLASS				
SS 316 Tubing & Fittings / per CV ##	This is in addition to SS316 Tubing and fittings which are integral part of CV		12 Meters of ¼ " SS316 Tubing, with 1 set of SS316 Fittings for each CV for connection to IA Header on one end and accessories on another end of CV and same shall be as per hook-up.		
## For further details refer " Annexure- 1".					COMPANY SEAL
					NAME
					SIGNATURE
					DATE

ANNEXURE-1

Air Filter Regulator (AFR)

Constant bleed type AFR with an accuracy of + 1.0 % inlet pressure range of 5-8 kg/ cm² and suitable spring ranges (AFR) for use with positioners in control valves, control damper, E/P convertors and shut off valves for phosphor bronze filter element; Filtering particles above five microns. Weather and water proof enclosure. Material of accessories will be SS316. Filter- regulators shall be suitable for a 10 kg/sq. cm maximum inlet pressure. Filter- regulators shall have built-in housing blow down valves and a 2 inch pressure gauge.

Solenoid Valves

Solenoid Valve coils shall be Class-H high-temperature or Class-F construction as applicable and shall be designed for continuous duty. Three-way solenoid valves shall be designed for universal operation so that the supply air may be connected to any port. Solenoid enclosures shall be NEMA-4)/ (Explosion proof for NEC Class-1, Division 1 area)/ flame proof (IEC-79.1, Part I) as applicable). Body material of solenoid valve shall be Die Cast Aluminium or SS316. All solenoid shall be with varister, LED indication, surge suppress diode and circuits.

Air Locks

Air locks shall be designed to shut off the diaphragm loading air line if the supply air pressure to the associated pilot or Positioner fails. Air locks shall be of the automatic reset type and shall be furnished with alarms.

Hand Wheels

Hand Wheels shall be provided. Hand wheels shall be side mounted unless specified to be top mounted. However the mounting shall be as decided during engineering to offer maximum accessibility.

Limit Switches

Each control Valves shall be provided with limit switches for monitoring of end position in DDCMIS/DCS/PLC. Switches shall have not less than two normally open and two normally closed contacts in both open and close directions. Electrical rating of the limit switch contacts shall be 240V AC, 5 amp or 220V DC, 0.5 amp. The enclosures of the limit switches shall be as per NEMA-4 Standard. Limit switches shall be constructed to withstand the temperatures encountered in the actual service. Explosion proof construction shall be furnished where required by applicable code or these specifications. Limit switches shall be factory mounted on the valves with provisions for adjusting the mounting.

Limit/micro switches can be offered as an integral part of Smart valve positioner.

Tubing and Air Sets

All pneumatic tubing required to interconnect devices assembled together shall be furnished complete with each control valve. The tubing shall be SS316 tubing conforming to ASTM B68 to B75 (USA). Swage lock flare less tubing fittings shall be used for tubing connections (Swage lock or approved equal).

ANNEXURE-1

Smart Valve Positioner

Control valve actuators for modulating and throttling services shall be provided with HART protocol based smart electro pneumatic valve Positioner to ensure accuracy & repeatability of response. The valve Positioner shall be designed suitable for vibration and service conditions of a steam electric power station.

The Positioner shall have the following features:

- a) Shall provide a pneumatic output signal of range 0.2 to 1.0 kg/cm² or as desired for the actuator.
- b) Shall have integral type position transmitter, input & output gauges, local keypad, display, 4-20 mA input and 4-20 mA output for position indication in DDCMIS/CCR/PLC.
- c) Shall be suitable for direct mounting on control valve assembly both for rotary & linear valves.
- d) Shall be capable of functioning under hot, humid & vibrating conditions.
- e) Shall have dust tight, corrosion resistant & weather proof IP 65 metal casing.
- f) Shall be operated at signal range of 4-20 mA for full travel of the valve. Split range operation in few case may be required. This facility shall also be available in positioner.
- g) Shall have in built mechanical position indicator.
- h) Shall have fail safe & fail freeze function as per loop process requirement.
- i) Shall have in built auto tune facility.

Junction Boxes

- i. Type : Flame proof/weather proof
- ii. Enclosure: IP-65/Explosion/Flame Proof as per area classification.
- iii. Material : FRP with protective Coating
- iv. Cable entry : Bottom or Side
- v. Cable glands: Double compression type – Nickel plated brass with PVC hoods.
- vi. Mounting : Indoor/Outdoor
- vii. No. of terminals: As required with standardization with 20% spare of each size & type.
- viii. Terminals: Screw less cage clamp type spring loaded
- ix. Grounding : Two terminals for body and shield ground
- x. Door: Hinged, lockable type.
- xi. Suitable mounting clamps and other accessories shall be in scope of bidder.
The brackets, bolts, nuts, screws, glands, lugs required for erection shall be of brass, included in bidder scope of supply. High voltage & insulation resistance test shall also be conducted. M6 Ni plated Brass earthing stud shall be provided (external 2 nos. internal 1 no.)
- xii. Gasket (Normal)- Neoprene thickness 6.0 mm



Technical specification for
Control Valves with Accessories
(Pneumatically Operated)
2 X 660 MW ENNORE SEZ STPP

SPEC NO.: PE-TS-412-145-I 104

VOLUME II B

SECTION D

REV. NO. 01

DATE 03.09.15

SHEET 110 OF 135

SECTION-D

DATA SHEETS -C



Technical specification for
Control Valves with Accessories
(Pneumatically Operated)
2 X 660 MW ENNORE SEZ STPP

SPECIFICATION NO **PE-TS-412-145-I104**VOLUME **II-B**SECTION **D**

REV. NO. 01

DATE: 03.09.15

SHEET 111

OF 135

NAME

SIGNATURE

DATE

Tag No..... Quantity.....

Data Sheet No. PES-145-06-DS2-0

DATA SHEET C

DATA SHEET – C FOR CONTROL VALVE (WITH PNEUMATIC ACTUATOR)
(TO BE FILLED BY THE BIDDER AFTER THE AWARD OF CONTRACT)

GENERAL	PROJECT	
	SERVICE	
	LOCATION	
	DUTY	
	PIPE SIZE (inlet / outlet)	
	PIPE MATERIAL (inlet / outlet)	
BODY	MODEL NUMBER	
	TYPE OF BODY : GUIDING : NO. OF PORTS	
	BODY SIZE : PORT SIZE : DESIGN CV	
	END CONNECTION & RATING (ANSI)	
	BODY MATERIAL	
	PACKING MATERIAL SINGLE / DOUBLE	
	BONNET TYPE / MATERIAL	
	TRIM FORM	
	TRIM MATERIAL : SEAT PLUG	
	TRIM MATERIAL : CAGE GUIDE	
	FLOW	
	OUTLET VELOCITY	
	REQUIRED LEAKAGE CLASS	
	NOISE LEVEL (dBA) (Spec. 3.1.14)	
VACUUM SERVICE		
ANTI CAVITATION TRIM		
PNEUMATIC ACTUATOR	MODEL NO. & SIZE	
	CLOSE AT : OPEN AT (Kg / Cm ² g)	
	TRAVEL TIME FOR OPEN TO CLOSE, CLOSE TO OPEN	
	VLV POSN. ON SIGNAL ELEC FAILURE	
	VALVE POSN. ON SUPPLY AIR FAILURE	
ACCESSORIES	POSITIONER	
	AIR FILTER REGULATOR	
	AIR LOCK RELAY	
	POSITION LIMIT SWITCH	
	POSITION TRANSMITTER	
	SOLENOID VALVE	
	E / P CONVERTER	
	JUNCTION BOX	
	HAND WHEEL (SIDE MOUNTED)	
	LOCAL POSITION INDICATOR	
ELECTRO PNEUMATIC POSITIONER		
PRESSURE GAUGES		

	Technical specification for Control Valves with Accessories (Pneumatically Operated) 2 X 660 MW ENNORE SEZ STPP	SPECIFICATION NO PE-TS-412-145-I104	
		VOLUME II-B	
		SECTION D	
		REV. NO. 01	DATE: 03.09.15
		SHEET 112	OF 135

Tag No.....		Quantity.....		Data Sheet No. PES-145-06-DS2-0					
DATA SHEET C									
DATA SHEET – C FOR CONTROL VALVE (WITH PNEUMATIC ACTUATOR) (TO BE FILLED BY THE BIDDER AFTER THE AWARD OF CONTRACT)									
PERFORMANCE OF VALVE	LINEARITY								
	HYSTERSIS								
	SENSITIVITY								
	ACCURACY								
SERVICE CONDITION*	SL.+ NO.	LOAD	FLOW (T/HR)	INLET PR. (KG/CM² (A))	OUTLET PR. (KG/CM² (A))	TEMP DEG. C	CALCULATED CV	% VALVE LIFT	VALVE O/L VELOCITY
VALVE TYPE									
* MAX SHUT OFF PRESS ((KG/CM ² g)									
* BODY DESIGN : PRESS ((KG/CM ² g) TEMP (DEG. C)									
* IBR FORM III-C									
TOTAL WEIGHT (VALVE + ACTUATOR + ACCESSORIES) KG.									



Technical specification for
Control Valves with Accessories
(Pneumatically Operated)

2 X 660 MW ENNORE SEZ STPP

SPEC NO.: PE-TS-412-145-I 104

VOLUME II B

SECTION D

REV. NO. 01 DATE : 03.09.15

SHEET 113 OF 135

SECTION-D

QUALITY PLAN

		QUALITY PLAN FOR CONTROL VALVE (PNEUMATIC)										QUALITY PLAN NO.: PE-QP-412-145-I 006			
												VOLUME			
												SECTION			
												REV. NO. 01		DATE: 03.09.15	
										SHEET 114 OF 135					

Sl. No.	Component / operation	Characteristics Checked	* Category	Type/Method of Check	Extent of Check	Reference documents	Acceptance Norms	Format of Records	Agency \$			Remarks
									P	W	V	
1.0	MATERIAL											
1.1	Body & Bonnet casting / forgings, plug, valve stem, seat ring/cage.	1. Physical, Chemical properties 2. Heat Treatment 3. Internal quality of castings 4. Surface Quality	MA	Physical, Chemical tests Review of H.T. Chart RT for Body & UT for Bonnet(NDT)	One/ Heat (HT Batch) Each H.T. 100%	Approved drg. / data sheet / BHEL specn. Approved drg. / data sheet / BHEL specn. ASME B 16.34	Approved drg. / data sheet / BHEL specn. Approved drg. / data sheet / BHEL specn. ASME B 16.34	Test Certificate Test Certificate Test Report / FILM	3	---	2,1,4	IBR Certification (if applicable) to be verified by BHEL Only for rating ANSI 900 and above. Applicable for Body and Bonnet only. For Lower rating only if called for in specification.
			MA	1. Visual 2. MT/PT	100% 100%	MSS-SP-55 ASME B 16.34	MSS-SP-55 ASME B 16.34	Test Certificate Test Certificate	3/2	---	2,1,4	After Machining on machined surface only

LEGEND: * CR - Critical characteristics MA - Major characteristics MI - Minor characteristics	RT- Radiographic Test UT - Ultrasonic Test NDT- Non Destructive Test	PT - Dye penetrant Test MT- Magnetic Test	\$ P - Agency Performing the Test. W - Agency Witnessing the Test. V - Agency Verifying the Test.	1 - BHEL 2 - Vendor 3 - Sub-vendor	4 - TANGEDCO
--	--	--	---	--	--------------



PEM :: C&I

QUALITY PLAN FOR CONTROL VALVE (PNEUMATIC)

QUALITY PLAN NO.: PE-QP-412-145-I 006

VOLUME

SECTION

REV. NO. 01 DATE: 03.09.15

SHEET 115 OF 135

Sl. No.	Component / operation	Characteristics Checked	* Category	Type/Method of Check	Extent of Check	Reference documents	Acceptance Norms	Format of Records	Agency \$			Remarks
									P	W	V	
1.2	Diaphragm	5. Pressure test for shell 1. Surface Quality 2. Hardness 3. Endurance / Life cycle	MA	Hyd. Test Visual Measurement Cyclic test 10,000 cycles	100% 100% 100% One / Type	ISA-S-75.19/ ASME B 16.34 Mfr. standard Mfr. standard 10,000 cycles/ Mfr. standard.	ISA-S-75.19/ ASME B 16.34 Mfr. standard Mfr. standard No damage	Test Certificate Test Certificate Test Certificate Test Certificate	2 3/2 3/2 3/2	2 --- --- ---	1,4 2,1,4 2,1,4 2,1,4	For Body & Bonnet after machining
1.3	Spring	1. Composition 2. Mech. Properties 3. Performance	MA	Chemical-Analysis Mech. Test 1. Stiffness ratio 2. Scragging 3. Cyclic test (Endurance) 4. Dimension (Measurement)	One sample/Heat One sample/Heat 100% 100% One / type	Material spec. / Mfr. standard Material spec. / Mfr. standard Material spec. / Mfr. standard Material spec. / Mfr. standard 10,000 cycles	Material spec. / Mfr. standard Material spec. / Mfr. standard Material spec. / Mfr. standard Material spec. / Mfr. standard	Test Certificate Test Certificate Test Certificate Test Certificate Record	3 3 3 3 3	--- --- --- --- ---	2,1,4 2,1,4 2,1,4 2,1,4 2,1,4	
1.4	Electrical items [Limit switches, Solenoids, Position Transmitter(if provided externally)]	1. Routine Test	MA	HV, IR, Continuity function	100% One sample/Lot	Rele. Standards Rele. Standards	Rele. Standards Appd Drg	Test Certificate Test Certificate	3 3	--- ---	2,1,4 2,1,4	In case TC is not available, Actual test shall be conducted

LEGEND:

* CR - Critical characteristics
MA - Major characteristics
MI - Minor characteristics

RT - Radiographic Test
UT - Ultrasonic Test
NDT - Non Destructive Test

PT - Dye penetrant Test
MT- Magnetic Test

\$ P - Agency Performing the Test.
W - Agency Witnessing the Test.
V - Agency Verifying the Test.

4 - TANGEDCO



PEM :: C&I

QUALITY PLAN FOR CONTROL VALVE (PNEUMATIC)

QUALITY PLAN NO.: **PE-QP-412-145-I 006**

VOLUME

SECTION

REV. NO. 01 DATE: 03.09.15

SHEET 116 OF 135

Sl. No.	Component / operation	Characteristics Checked	* Category	Type/Method of Check	Extent of Check	Reference documents	Acceptance Norms	Format of Records	Agency \$			Remarks
									P	W	V	
1.5	Pressure Gauges	2. Degree of protection 1. Performance 2. Marking	MA	IP/NEMA Tests Review of calibration certificates Visual	One sample / type 100% 100%	Approved Data sheet Mfr. Standard/ Approved drg. / data sheet Mfr. Standard/ Approved drg. / data sheet	Approved Data sheet	Test Certificate Test Certificate Records	3 3 3	---	2,1,4 2,1,4 2,1,4	
2.0	IN PROCESS INSPECTION											
2.1	After machining, i, Body ii Bonnet iii Plug iv Valve Stem v seat ring/cage	1. Surface flaws	MA	Visual & MT/PT	100% (on accessible surfaces)	ASME B 16.34	ASME B 16.34	Test Records	2	---	1,4	Butt weld ends shall be included.
2.2	Lapping	2. Dimensional checks 3. Hard facing (wherever applicable) Machining surface contact	MA	Measurement Hardness Measurement Blue Matching	100% One sample/Lot One sample/lot	Mfr. Standard/ Approved drg. / data sheet Mfr. Standard/ Approved drg. / data sheet ----- Mfr. Standard/ Approved drg. / data sheet	Mfr. Standard/ Approved drg. / data sheet Mfr. Standard/ Approved drg. / data sheet Proper Physical Contact	Records Records ---	2 2 2	---	1,4 1,4 ---	
3.0	TESTS ON COMPLETED VALVE											
3.1	Actuator Chamber	Leakage & Strength	MA	Pneumatic test	100%	Mfr. Standard/ Approved drg. / data sheet	No Leakage	Test Certificate	2	1,4	1,4	Refer Note-4

LEGEND: * CR - Critical characteristics RT- Radiographic Test PT - Dye penetrant Test \$ P - Agency Performing the Test. 1 - BHEL 4 - TANGEDCO
 MA - Major characteristics UT - Ultrasonic Test MT- Magnetic Test W - Agency Witnessing the Test. 2 - Vendor
 MI - Minor characteristics NDT- Non Destructive Test V - Agency Verifying the Test. 3 - Sub-vendor



PEM :: C&I

QUALITY PLAN FOR CONTROL VALVE (PNEUMATIC)

QUALITY PLAN NO.: **PE-QP-412-145-I 006**
 VOLUME
 SECTION
 REV. NO. 01 DATE: 03.09.15
 SHEET 117 OF 135

Sl. No.	Component / operation	Characteristics Checked	* Category	Type/Method of Check	Extent of Check	Reference documents	Acceptance Norms	Format of Records	Agency \$			Remarks		
									P	W	V			
3.2	Body	Leakage and Pressure test (Body Mount Leakage)	MA	Hydro test	100%	ISA - S-75.19	No Leakage	Test Certificate	2	1,4	1,4	1,4	Refer Note-4	
3.3	Seat leakage test for completed valve	Seat Leakage	MA	Pneumatic Test	100%	FCI-70.2	FCI-70.2	Test Certificate	2	1,4	1,4	1,4	Refer Note-4	
4.0	OPERATION TEST ON COMPLETED VALVE (Final inspection)	1. Valve Travel	MA	Measurement	100%	Approved drg. / data sheet	Approved drg. / data sheet	Test Report	2	1,4	1,4	1,4	Refer Note-4	
		2. Opening/Closing time	MA	Measurement	100%	Approved drg. / data sheet	Approved drg. / data sheet	Test Report	2	1,4	1,4	1,4	Refer Note-4	
		3. Linearity/cam characteristic	MA	Measurement	100%	Approved drg. / data sheet	Approved drg. / data sheet	Test Report	2	1,4	1,4	1,4	Refer Note-4	
		4. Repeatability	MA	Measurement	100%	Approved drg. / data sheet	Approved drg. / data sheet	Test Report	2	1,4	1,4	1,4	Refer Note-4	
		5. Hysteresis	MA	Measurement	100%	Approved drg. / data sheet	Approved drg. / data sheet	Test Report	2	1,4	1,4	1,4	Refer Note-4	
		6. Sensitivity	MA	Measurement	100%	Approved drg. / data sheet	Approved drg. / data sheet	Test Report	2	1,4	1,4	1,4	Refer Note-4	
		7. Accuracy (Overall)	MA	Measurement	100%	Approved drg. / data sheet	Approved drg. / data sheet	Test Report	2	1,4	1,4	1,4	Refer Note-4	
		8. Control Valve characteristics / CV Test	MA	Measurement (Press. vs. discharge and discharge vs. opening 0-100% in steps of 10%)	One per type	As per specs/ Approved drg. / data sheet	As per specs/ Approved drg. / data sheet	Test Certificate	2	4	1,4	1,4	1,4	Size = Body & port size Or Body size & CV for non std port. Refer Note 1.
		9. FL factor	MA	Measurement	One per type	As per specs/ Approved drg. / data sheet	As per specs/ Approved drg. / data sheet	Test Certificate	2	4	1,4	1,4	1,4	

LEGEND: * CR - Critical characteristics RT - Radiographic Test PT - Dye penetrant Test
 MA - Major characteristics UT - Ultrasonic Test MT - Magnetic Test
 MI - Minor characteristics NDT - Non Destructive Test
 \$ P - Agency Performing the Test. 1 - BHEL
 W - Agency Witnessing the Test. 2 - Vendor
 V - Agency Verifying the Test. 3 - Sub-vendor
 4 - TANGEDCO



PEM :: C&I

QUALITY PLAN FOR CONTROL VALVE (PNEUMATIC)

QUALITY PLAN NO.: **PE-QP-412-145-I 006**
 VOLUME
 SECTION
 REV. NO. 01 DATE: 03.09.15
 SHEET 118 OF 135

Sl. No.	Component / operation	Characteristics Checked	* Category	Type/Method of Check	Extent of Check	Reference documents	Acceptance Norms	Format of Records	Agency \$			Remarks
									P	W	V	
		10. Operation of limit switch & solenoids and other accessories	MA	Function	100%	Approved drg. / data sheet	As per specs/ Approved drg. / data sheet	Test Report	2	1,4	1,4	On assembled valve Refer Note-4
		11. Overall dimensions	MI	Visual and dimensional	100%	Approved drg. / data sheet	As per specs/ Approved drg. / data sheet	Records	2	1,4	1,4	Refer Note-4
		12. Pre defined valve position in case of air failure	MA	Visual	100%	As per spec & Appd drg	As per spec & Appd drg	Test Certificate	2	1,4	1,4	
		13. Cleanliness, painting, stamping (for direction of flow), Tag No.	MA	Visual and dimensional	100%	Approved drg. / data sheet	As per specs/ Approved drg. / data sheet	Test Certificate	2	1,4	1,4	
5.0	AUXILIARY ITEMS (Performance test of auxiliary items shall be performed on the completely assembled valve)											
5.1	Positioner	Overall leakage after assembly including Nozzles leakage	MA	Leak Test (in the steady state input signal)	100 %	Mfr. Standard/ Approved drg. / data sheet	No leakage	Test Certificate	3/2	---	1,4	Overall leakage including tubing
5.2	Air filter regulator	1. Normal air consumption	MA	Measurement	Each type	Mfr. Standard/ Approved drg. / data sheet	No leakage	Test Certificate	3/2	---	1,4	
		2. Overall leakage	MA	Visual (soap solution)	100 %	Mfr. Standard/ Approved drg. / data sheet	No leakage	Test Certificate	3/2	---	1,4	
5.3	Air lock relay	Performance Test	MA	Leakage test	100%	Mfr. Standard/ Approved drg. / data sheet	No leakage	Test Certificate	3/2	---	1,4	

LEGEND: * CR - Critical characteristics RT - Radiographic Test PT - Dye penetrant Test \$ P - Agency Performing the Test. 1 - BHEL
 MA - Major characteristics UT - Ultrasonic Test MT - Magnetic Test W - Agency Witnessing the Test. 2 - Vendor
 MI - Minor characteristics NDT- Non Destructive Test V - Agency Verifying the Test. 3 - Sub-vendor

4 - TANGEDCO



PEM :: C&I

QUALITY PLAN FOR CONTROL VALVE (PNEUMATIC)

QUALITY PLAN NO.: PE-QP-412-145-I 006

VOLUME

SECTION

REV. NO. 01 DATE: 03.09.15

SHEET 119 OF 135

Sl. No.	Component / operation	Characteristics Checked	* Category	Type/Method of Check	Extent of Check	Reference documents	Acceptance Norms	Format of Records	Agency \$			Remarks
									P	W	V	
5.4	Electronic position transmitter(not applicable if provided integral to smart positioner)	1. Accuracy	MA	Operation	100%	Approved data sheet	Approved data sheet	Test Certificate	2	1,4	1,4	
5.5	Current to Pneumatic converter(not applicable for smart positioner)	1. Physical Verification Make/Model 2. Degree of Protection 3. Linearity 4. Hysteresis	MA CR CR	Visual Measurement Measurement	100% Each type 100% 100%	Approved drg. / data sheet Relevant Standard Approved drg. / data sheet / BHEL specn. Approved drg. / data sheet / BHEL specn.	Approved drg. / data sheet Relevant Standard Approved drg. / data sheet / BHEL specn.	Test Certificate Test Certificate Inspection Report Inspection Report	2 3 2 2	---	2,1,4 2,1,4 1,4 1,4	
5.6	Smart Positioner (As Applicable)	1. Physical Verification Make/Model 2. Degree of Protection 3. Linearity 4. Hysteresis 5. Calibration with Hand Held Communicator	MA MA CR CR MA	Visual IP/NEMA test Measurement Measurement Measurement	100% Each type 100% 100% Each type	Approved drg. / data sheet Relevant Standard Approved drg. / data sheet / BHEL specn. Approved drg. / data sheet / BHEL specn. Approved data sheet / Mfr. Standard	Approved drg. / data sheet Relevant Standard Approved drg. / data sheet / BHEL specn. Approved drg. / data sheet / BHEL specn. Approved data sheet / Mfr. Standard	Test Certificate Test Certificate Inspection Report Inspection Report Test Certificate	2 3 2 2 2	---	2,1,4 2,1,4 1,4 1,4 1,4	

LEGEND:

* CR - Critical characteristics
MA - Major characteristics
MI - Minor characteristics

RT- Radiographic Test
UT - Ultrasonic Test
NDT- Non Destructive Test

PT - Dye penetrant Test
MT- Magnetic Test

\$ P - Agency Performing the Test.
W - Agency Witnessing the Test.
V - Agency Verifying the Test.

1 - BHEL
2 - Vendor
3 - Sub-vendor

4 - TANGEDCO

 QUALITY PLAN FOR CONTROL VALVE (PNEUMATIC)		QUALITY PLAN NO.: PE-QP-412-145-I 006					
		VOLUME					
		SECTION					
		REV. NO. 01		DATE: 03.09.15		SHEET 120 OF 135	

Sl. No.	Component / operation	Characteristics Checked	* Category	Type/Method of Check	Extent of Check	Reference documents	Acceptance Norms	Format of Records	Agency \$			Remarks
									P	W	V	
6.0	PAINTING	Soundness of Painting	MA	Visual and Measurement	100%	BHEL specn. / Mfr. Standard	BHEL specn. / Mfr. Standard	Inspection Report	2	---	---	Refer Note-2
7.0	PACKING	Soundness of Packing against transit damage	MA	Visual	100%	Mfr. Standard/ Approved drg. / data sheet	Mfr. Standard/ Approved drg. / data sheet	Inspection Report	2	---	---	Refer Note-3

NOTES:

1. CV test shall be conducted at FCRI/Any govt. approved laboratory/ BHEL approved Laboratory for each type & size of control valve.
2. In the absence of BHEL spec. for painting, vendor to obtain BHEL's approval on their painting specification / procedure.
3. Sea worthy packing shall be provided, if applicable.
4. The quantum of check shall be 100% for manufacturer and 10% for BHEL/BHEL nominated inspection agency.
5. IBR certificates in Form III-C shall be submitted if called for in the specification/datasheet.
6. Copies of all TC's (Test Certificates) for materials duly correlated with Heat Nos., TC's for electrical items and mechanical tests(Leak/Operation) shall be submitted to BHEL & TANGEDCO for verification and acceptance.
7. Test certificates for following accessories to be provided to BHEL & TANGEDCO for verification:

S.No.	Accessories	Type of test
1	Air Filter Regulator	Calibration Test Accuracy Test
2.	Solenoid Valves	Hydro Test Seat Leakage Test Coil Insulation Test
3.	Junction Box	IP Class

<p>LEGEND:</p> <ul style="list-style-type: none"> * CR - Critical characteristics MA - Major characteristics MI - Minor characteristics 	<ul style="list-style-type: none"> RT- Radiographic Test UT - Ultrasonic Test NDT- Non Destructive Test 	<ul style="list-style-type: none"> PT - Dye penetrant Test MT- Magnetic Test 	<ul style="list-style-type: none"> \$ P - Agency Performing the Test. W - Agency Witnessing the Test. V - Agency Verifying the Test. 	<ul style="list-style-type: none"> 1 - BHEL 2 - Vendor 3 - Sub-vendor 	<p>4 - TANGEDCO</p>
---	--	--	---	--	---------------------



Technical specification for
Control Valves with Accessories
(Pneumatically Operated)

2 X 660 MW ENNORE SEZ STPP

SPEC NO.: **PE-TS-412-145-I 104**

VOLUME II B

SECTION D

REV. NO. 01

DATE 03.09.15

SHEET 121

OF 135

SECTION-D

BILL OF QUANTITY



Technical specification for
Control Valves with Accessories
(Pneumatically Operated)

2 X 660 MW ENNORE SEZ STPP

SPECIFICATION NO. PE-TS-412-145-I104

VOLUME **II-B**

SECTION **D**

REV. NO. 01

DATE: 03.09.15

SHEET 122

OF 135

BILL OF QUANTITY

**[A] CONTROL VALVES COMPLETE WITH SMART POSITIONER
AND ALL ACCESSORIES MOUNTED, TUBED AND TERMINATED ON JB**

Sl. No.	TAG NO.	SERVICE/ ITEM DESCRIPTION	QTY/UNIT	QTY FOR 2 UNITS
1	ASV-8	D/A PEGGING FROM AUX. STEAM HEADER	1	2
2	CRHV-6	D/A PEGGING FROM AUX. CRH LINE	1	2
3	CDV-22/25	MAIN CONDENSATE CONTROL	2	4
4	CDV-39	CEP & GSC MIN. FLOW RECIRCULATION	1	2
5	CDV-43	EXCESS RETURN TO CST	1	2
6	CDV-67	CONDENSATE SPRAY TO SD FLASH TANK	1	2
7	CDV-72	CONDENSATE FOR VALVE GLAND SEALING	1	2
8	DRV-2	HPH-7 NORMAL DRAIN TO HPH-6	1	2
9	DRV-5	HPH-7 ALT. DRAIN TO F/T	1	2
10	DRV-15	HPH-6 NORMAL DRAIN TO DEAERATOR	1	2
11	DRV-18	HPH-6 ALT. DRAIN TO F/T	1	2
12	DRV-28	LPH-3 NORMAL DRAIN TO LPH-2	1	2
13	DRV-31	LPH-3 ALT. DRAIN TO F/T	1	2
14	DRV-34	LPH-2 NORMAL DRAIN TO LPH-1	1	2
15	DRV-37	LPH-2 ALT. DRAIN TO F/T	1	2
16	DRV-48	DEAERATOR OVERFLOW TO F/T	1	2
17	DRV-53	HPH-8 NORMAL DRAIN TO HPH-7	1	2
18	DRV-59	HPH-8 ALT. DRAIN TO F/T	1	2
19	DRV-65	LPH-4 NORMAL DRAIN TO LPH-3	1	2
20	DRV-68	LPH-4 ALT. DRAIN TO F/T	1	2
21	DMV-40	LOW CAPACITY DM MU TO HOTWELL	1	2
22	DMV-63	HIGH CAPACITY DM MU TO HOTWELL	1	2
23	FDV-14	LOW LOAD FEED CONTROL	1	2
[B]	¼" SS TUBING (To be supplied Loose)		300 metres	600 metres
[C]	FITTINGS: (To be supplied Loose)	(i) SS FITTINGS for Connection to Air Filter Regulator, Air Lock Relay, IA Header isolation valve and SS EQUAL TEES	1 Lot	2 Lots
[D]	Valve Diagnostic Software		1 No.	2 Nos.



Technical specification for
Control Valves with Accessories
(Pneumatically Operated)
2 X 660 MW ENNORE SEZ STPP

SPEC NO.: PE-TS-412-145-I104

VOLUME II B

SECTION D

REV. NO. 01 DATE 03.09.15

SHEET 122A OF 135

SECTION-D

SPARES

	DATA SHEET FOR CONTROL VALVES (WITH PNEUMATIC ACTUATOR) 2 X 660 MW ENNORE STPP	SPECIFICATION NO. PE-TS-412-145-1104	
		VOLUME	IIB
		SECTION	D
		REV. NO. 01	DATE: 03.09.2015
		SHEET 123	OF 135

LIST OF COMMISSIONING SPARES

SI. No.	ITEM DESCRIPTION	QUANTITY
1.	Gaskets	One (1) set with each control valve Tag
2.	Gland Packings	One (1) set with each control valve Tag

LIST OF MANDATORY SPARES (except Feed Control Valve)

	ITEM DESCRIPTION	QUANTITIES/PER UNIT
1.	Control Valve Stem Packing	1 Set for each control valve
2.	Actuator Soft Goods kit	
a.	Rubber Diaphragms	2 Nos. for each control valve
b.	O-rings and Rubber Gaskets	1 Set for each control valve
3.	Lubricants for gaskets on one year consumption basis.	100 % quantity of lubricants for gaskets for each control valve on one year consumption basis
4.	Limit Switches	2 Sets for each control valve
5.	Smart Positioner	1 Set for each control valve
6.	Valve Trims(such as plug, stem, seat ring cage, guide bushing, stem lock pin, packing, retaining ring, etc.)	1 Set for each control valve
7.	Complete Actuator	1 complete actuator of each type or min. 10% of each type and size whichever is more.
8.	Solenoid Valves	20% of solenoid valves or min. 2 nos. of each type for total quantity of control valves
9.	Pressure regulators(Air filter Regulators)	20% of each type
10.	Air Lock Relay	20% or min. 2 nos. of each type, whichever is more

LIST OF MANDATORY SPARES (for Feed Control Valve)

	ITEM DESCRIPTION	QUANTITIES/PER UNIT
1.	Metal seat	1 Set
2.	Seat ring	1 Set
3.	Spindle	1 Set
4.	Actuator Soft Goods kit	1 Set
5.	Solenoid valves	2 Nos.
6.	Air filter regulators	2 Nos.
7.	Air Lock Relay	2 Nos.
8.	Complete Actuator for each type & model	1 Set
9.	Smart Positioner	1 Set for each control valve

NOTE- The quantity mentioned above for mandatory spares is for 1 unit. For 2 units, the quantity shall be multiplied by 2.

	<p>Technical specification for Control Valves with Accessories (Pneumatically Operated) 2 X 660 MW ENNORE SEZ STPP</p>	SPECIFICATION NO. PE-TS-412-145-1104	
		VOLUME II-B	
		SECTION D	
		REV. NO. 01	DATE: 03.09.15
		SHEET 124	OF 135

SECTION – D

SUB VENDORS LIST

	Technical specification for Control Valves with Accessories (Pneumatically Operated) 2 X 660 MW ENNORE SEZ STPP	SPECIFICATION NO. PE-TS-412-145-I104	
		VOLUME II-B	
		SECTION D	
		REV. NO. 01	DATE: 03.09.15
		SHEET 125	OF 135

SUB VENDOR LIST

- | | |
|-------------------------|--|
| 1. Air Filter regulator | Placka/ Shavo Norgan/ ABB/Bells Control/Schrader/Veljan |
| 2. Solenoid | ASCO/Avcon/ Rotex/ Schrader/ Herion Norgren/ Schovill
Duncan Ltd. |
| 3. Smart Positioner | Metso/ Emerson/ Seimens/ ABB/ Flow Serve/ Foxboro/ Yamatake |

	Technical specification for Control Valves with Accessories (Pneumatically Operated) 2 X 660 MW ENNORE SEZ STPP	SPECIFICATION NO. PE-TS-412-145-1104	
		VOLUME II-B	
		SECTION D	
		REV. NO. 01	DATE: 03.09.15
		SHEET 126	OF 135

SCHEDULE OF SUBMISSION OF DRAWINGS / DOCUMENTS, EQUIPMENT MANUFACTURE INSPECTION AND DESPATCH

1.	<u>ZERO DATE</u>	<u>DATE of LOI / FOI / TOI</u>
2.	Submission of Data Sheets / documents / catalogues / Valve sizing calculations / Noise calculations for approval.	2 Weeks from the Zero date.
3.	Technical finalisation, freezing of inputs of manufacture by way of vetting of documents and technical discussions and resubmissions of documents (if required)	6 Weeks from the Zero date.
4.	Inspection of Equipment as per Approved (Category-I) drawings / documents.	24 Weeks from the Zero date.
5.	Release of MDCC by BHEL	26 Weeks from the Zero date.
6.	Dispatch (Packaging & Dispatch)	26 Weeks from the Zero date.
7.	Final documents submission as per Contract	28 Weeks from the Zero date.

NOTE: Delays due to non-fulfillment of the requirements of approved Quality Plan and approved Data sheets, Drawings, Catalogues and Sizing Calculations observed during inspection shall be to the Vendor's account.

Delays due to INCOMPLETE (Partly) submission of Data sheets, Drawings, Catalogues and Sizing Calculations also be considered as **"DOCUMENTS NOT SUBMITTED"**

(Signature and Stamp of the Bidder)

TAMIL NADU GENERATION AND DISTRIBUTION COMPANY

2 X 660 MW ENNORE SEZ STPP

TECHNICAL SPECIFICATION
FOR
CONTROL VALVES WITH ACCESSORIES
(Pneumatically Operated)

VOLUME III

SPECIFICATION No: PE-TS-412-145-I 104



BHARAT HEAVY ELECTRICALS LIMITED
POWER SECTOR
PROJECT ENGINEERING MANAGEMENT DIVISION
NOIDA, INDIA

	Technical specification for Control Valves with Accessories (Pneumatically Operated) 2 X 660 MW ENNORE SEZ STPP	SPEC NO.: PE-TS-412-145-I104	
		VOLUME III	
		SECTION	
		REV. NO. 01	DATE: 03.09.15
		SHEET 128 OF	135

CONTENTS

VOL-III

Sl. No.	DESCRIPTION	No. of sheets
1.	SCHEDULE OF DRAWINGS, DATA SHEETS, DOCUMENTS, AND CATALOGUES SUBMITTED WITH THE BID	1
2.	SCHEDULE OF PRICES	2
3.	SCHEDULE OF UNIT PRICES	1
4.	Cv TEST CHARGES	1
5.	FL TEST CHARGES	1
6.	INSPECTION SCHEDULE	1
7.	DEVIATION SCHEDULE	1



Technical specification for
Control Valves with Accessories
(Pneumatically Operated)
2 X 660 MW ENNORE SEZ STPP

SPECIFICATION NO. : PE-TS-412-145-II04

VOLUME III

SECTION

REV. NO. 01

DATE: 03.09.15

SHEET 129

OF

135

**SCHEDULE OF DRAWINGS, DATASHEETS, DOCUMENTS, CATALOGUES
SUBMITTED WITH THE BID**

PARTICULARS OF THE BIDDER / AUTHORISED REPRESENTATIVE

PARTICULARS OF THE BIDDER / AUTHORISED REPRESENTATIVE				
NAME	DESIGNATION	SIGNATURE	DATE	COMPANY SEAL



**Technical specification for
Control Valves with Accessories
(Pneumatically Operated)**

2 X 660 MW ENNORE SEZ STPP

SPECIFICATION NO. : PE-TS-412-145-II04

VOLUME III

SECTION

REV. NO. 01

DATE: 03.09.15

SHEET 130 OF 135

SCHEDULE OF PRICES

**[A] CONTROL VALVES COMPLETE WITH SMART POSITIONER
AND ALL ACCESSORIES MOUNTED, TUBED AND TERMINATED ON JB**

Sl. No.	TAG NO.	SERVICE/ ITEM DESCRIPTION	PRICE PER UNIT	TOTAL PRICE FOR 2 UNITS
1	ASV-8	D/A PEGGING FROM AUX. STEAM HEADER		
2	CRHV-6	D/A PEGGING FROM AUX. CRH LINE		
3	CDV-22	MAIN CONDENSATE CONTROL		
4	CDV-25	MAIN CONDENSATE CONTROL		
5	CDV-39	CEP & GSC MIN. FLOW RECIRCULATION		
6	CDV-43	EXCESS RETURN TO CST		
7	CDV-67	CONDENSATE SPRAY TO SD FLASH TANK		
8	CDV-72	CONDENSATE FOR VALVE GLAND SEALING		
9	DRV-2	HPH-7 NORMAL DRAIN TO HPH-6		
10	DRV-5	HPH-7 ALT. DRAIN TO F/T		
11	DRV-15	HPH-6 NORMAL DRAIN TO DEAERATOR		
12	DRV-18	HPH-6 ALT. DRAIN TO F/T		
13	DRV-28	LPH-3 NORMAL DRAIN TO LPH-2		
14	DRV-31	LPH-3 ALT. DRAIN TO F/T		
15	DRV-34	LPH-2 NORMAL DRAIN TO LPH-1		
16	DRV-37	LPH-2 ALT. DRAIN TO F/T		
17	DRV-48	DEAERATOR OVERFLOW TO F/T		
18	DRV-53	HPH-8 NORMAL DRAIN TO HPH-7		
19	DRV-59	HPH-8 ALT. DRAIN TO F/T		
20	DRV-65	LPH-4 NORMAL DRAIN TO LPH-3		
21	DRV-68	LPH-4 ALT. DRAIN TO F/T		
22	DMV-40	LOW CAPACITY DM MU TO HOTWELL		
23	DMV-63	HIGH CAPACITY DM MU TO HOTWELL		
24	FDV-14	LOW LOAD CONTROL VALVE		
[B]	300 meters OF SS TUBING (Per Unit) FOR CONNECTION BETWEEN IA HEADER ON ONE END AND ACCESSORIES ON THE OTHER END OF CV			
[C]	1 LOT OF SS FITTINGS for Connection to Air Filter Regulator, Air Lock Relay, IA Header isolation valve and SS EQUAL TEES (AS PER HOOK-UP DIAGRAM)			
[D]	START-UP/COMMISSIONING SPARES(SEPARATE SHEET WITH BREAK UP TO BE ATTACHED)			
	(i) 1 SET OF BODY AND BONNET GASKETS FOR EACH CV			
	(ii) 1 SET OF GLAND PACKINGS FOR EACH CV			
[E]	MANDATORY SPARES AS PER LIST ENCLOSED IN SECTION D (SEPARATE SHEET WITH BREAK UP TO BE ATTACHED)			
[F]	VALVE DIAGNOSTIC SOFTWARE			
[G]	Cv TEST CHARGES FOR EACH TYPE OF CONTROL VALVE			
[H]	FL TEST CHARGES FOR EACH TYPE OF CONTROL VALVE			

	Technical specification for Control Valves with Accessories (Pneumatically Operated) 2 X 660 MW ENNORE SEZ STPP	SPECIFICATION NO. : PE-TS-412-145-II04	
		VOLUME III	
		SECTION	
		REV. NO. 01	DATE: 03.09.15
		SHEET 131 OF 135	

SCHEDULE OF UNIT PRICES

CONTROL VALVE ACCESSORIES

S. No.	ITEMS	UNIT PRICE
1. \$	POSITIONER EACH MODEL AND TYPE	
2.	AIR FILTER REGULATOR	
3.	AIR LOCK RELAY	
4. \$	POSITION LIMIT SWITCH OF EACH MODEL AND TYPE	
5.	ELECTRONIC POSITION TRANSMITTER OF EACH MODEL AND TYPE	
6.	SOLENOID VALVE	
7.	VOLUME BOOSTER (PNEUMATIC RELAY)	
8. \$	PRESSURE GAUGES OF EACH TYPE	
9.	JUNCTION BOX (36 WAYS)	
10.	HANDWHEEL	
11. \$	ACTUATOR OF EACH TYPE	
12.	SS FITTING FOR CONNECTION TO AIR FILTER REGULATOR	
13.	SS FITTING FOR CONNECTION TO AIR LOCK RELAY	
14.	SS FITTINGS FOR CONNECTING TO AIR HEADER	
15.	SS EQUAL TEE	
16.	SS TUBING PER METRE	
17. \$	VALVE STEM WITH PLUG & SEAT RING EACH SIZE & TYPE	
18. \$	GASKET OF EACH SIZE AND TYPE	
19. \$	BODY SEAL GASKETS OF EACH SIZE AND TYPE	
20. \$	CAGE OF EACH SIZE AND TYPE	
21. \$	GLAND PACKING EACH SIZE AND TYPE	
22. \$	VALVE TRIM OF EACH SIZE AND TYPE	
23. \$	DIAPHRAM OF EACH SIZE AND TYPE	
24. \$	SEAL BOX "O" RING OF EACH TYPE AND SIZE	
25. \$	COLOR "O" RING OF EACH TYPE AND SIZE	
26.	POSITION TRANSMITTER	
27.	MOISTURE SEPARATOR	

NOTE

\$: Separate list to be attached for each size and type of these control valve accessories.

PARTICULARS OF THE BIDDER / AUTHORISED REPRESENTATIVE				
NAME	DESIGNATION	SIGNATURE	DATE	COMPANY SEAL



Technical specification for
Control Valves with Accessories
(Pneumatically Operated)

2 X 660 MW ENNORE SEZ STPP

SPECIFICATION NO. : PE-TS-412-145-II04

VOLUME III

SECTION

REV. NO. 01

DATE: 03.09.15

SHEET 132 OF 135

CV TEST CHARGES

S.NO.	ITEM DESCRIPTION		CV TEST CHARGES
S. No.	TAG NO.	SERVICE	
1	ASV-8	D/A PEGGING FROM AUX. STEAM HEADER	
2	CRHV-6	D/A PEGGING FROM AUX. CRH LINE	
3	CDV-22	MAIN CONDENSATE CONTROL	
4	CDV-25	MAIN CONDENSATE CONTROL	
5	CDV-39	CEP & GSC MIN. FLOW RECIRCULATION	
6	CDV-43	EXCESS RETURN TO CST	
7	CDV-67	CONDENSATE SPRAY TO SD FLASH TANK	
8	CDV-72	CONDENSATE FOR VALVE GLAND SEALING	
9	DRV-2	HPH-7 NORMAL DRAIN TO HPH-6	
10	DRV-5	HPH-7 ALT. DRAIN TO F/T	
11	DRV-15	HPH-6 NORMAL DRAIN TO DEAERATOR	
12	DRV-18	HPH-6 ALT. DRAIN TO F/T	
13	DRV-28	LPH-3 NORMAL DRAIN TO LPH-2	
14	DRV-31	LPH-3 ALT. DRAIN TO F/T	
15	DRV-34	LPH-2 NORMAL DRAIN TO LPH-1	
16	DRV-37	LPH-2 ALT. DRAIN TO F/T	
17	DRV-48	DEAERATOR OVERFLOW TO F/T	
18	DRV-53	HPH-8 NORMAL DRAIN TO HPH-7	
19	DRV-59	HPH-8 ALT. DRAIN TO F/T	
20	DRV-65	LPH-4 NORMAL DRAIN TO LPH-3	
21	DRV-68	LPH-4 ALT. DRAIN TO F/T	
22	DMV-40	LOW CAPACITY DM MU TO HOTWELL	
23	DMV-63	HIGH CAPACITY DM MU TO HOTWELL	
24	FDV-14	LOW LOAD FEED CONTROL VALVE	

NOTE: a) CHARGES TO BE INDICATED AGAINST EACH TAG NO.

b) CV TEST TO BE CONDUCTED FOR ONE PER TYPE PER SIZE, CV VALUE, TAG NOS. TO BE GROUPED ACCORDINGLY AND INDICATED

PARTICULARS OF THE BIDDER / AUTHORISED REPRESENTATIVE				
NAME	DESIGNATION	SIGNATURE	DATE	COMPANY SEAL



Technical specification for
Control Valves with Accessories
(Pneumatically Operated)

2 X 660 MW ENNORE SEZ STPP

SPECIFICATION NO. : PE-TS-412-145-II04

VOLUME III

SECTION

REV. NO. 01

DATE: 03.09.15

SHEET 133 OF 135

FL TEST CHARGES

S.NO.	ITEM DESCRIPTION		FL TEST CHARGES
S. No.	TAG NO.	SERVICE	
1	ASV-8	D/A PEGGING FROM AUX. STEAM HEADER	
2	CRHV-6	D/A PEGGING FROM AUX. CRH LINE	
3	CDV-22	MAIN CONDENSATE CONTROL	
4	CDV-25	MAIN CONDENSATE CONTROL	
5	CDV-39	CEP & GSC MIN. FLOW RECIRCULATION	
6	CDV-43	EXCESS RETURN TO CST	
7	CDV-67	CONDENSATE SPRAY TO SD FLASH TANK	
8	CDV-72	CONDENSATE FOR VALVE GLAND SEALING	
9	DRV-2	HPH-7 NORMAL DRAIN TO HPH-6	
10	DRV-5	HPH-7 ALT. DRAIN TO F/T	
11	DRV-15	HPH-6 NORMAL DRAIN TO DEAERATOR	
12	DRV-18	HPH-6 ALT. DRAIN TO F/T	
13	DRV-28	LPH-3 NORMAL DRAIN TO LPH-2	
14	DRV-31	LPH-3 ALT. DRAIN TO F/T	
15	DRV-34	LPH-2 NORMAL DRAIN TO LPH-1	
16	DRV-37	LPH-2 ALT. DRAIN TO F/T	
17	DRV-48	DEAERATOR OVERFLOW TO F/T	
18	DRV-53	HPH-8 NORMAL DRAIN TO HPH-7	
19	DRV-59	HPH-8 ALT. DRAIN TO F/T	
20	DRV-65	LPH-4 NORMAL DRAIN TO LPH-3	
21	DRV-68	LPH-4 ALT. DRAIN TO F/T	
22	DMV-40	LOW CAPACITY DM MU TO HOTWELL	
23	DMV-63	HIGH CAPACITY DM MU TO HOTWELL	
24	FDV-14	LOW LOAD FEED CONTROL VALVE	

NOTE: a) CHARGES TO BE INDICATED AGAINST EACH TAG NO.

b) FL TEST TO BE CONDUCTED FOR ONE PER TYPE PER SIZE. TAG NOS. TO BE GROUPED ACCORDINGLY AND INDICATED

PARTICULARS OF THE BIDDER / AUTHORISED REPRESENTATIVE

NAME	DESIGNATION	SIGNATURE	DATE	COMPANY SEAL



Technical specification for
Control Valves with Accessories
(Pneumatically Operated)
2 X 660 MW ENNORE SEZ STPP

SPECIFICATION NO. : PE-TS-412-145-II04

VOLUME III

SECTION

REV. NO. 01

DATE: 03.09.15

SHEET 134 OF 135

INSPECTION SCHEDULE

(PLACE & ADDRESS OF TESTING/ INSPECTION AND ITS SCHEDULE DATE & DURATION IN NUMBER OF DAYS ITEM/COMPONENTWISE TO BE LISTED)

PARTICULARS OF THE BIDDER / AUTHORISED REPRESENTATIVE				
NAME	DESIGNATION	SIGNATURE	DATE	COMPANY SEAL



Technical specification for
Control Valves with Accessories
(Pneumatically Operated)

2 X 660 MW ENNORE SEZ STPP

SPECIFICATION NO. : PE-TS-412-145-II04

VOLUME III

SECTION

REV. NO. 01

DATE: 03.09.15

SHEET 135 OF 135

DEVIATION SCHEDULE

PARTICULARS OF THE BIDDER / AUTHORISED REPRESENTATIVE

PARTICULARS OF THE BIDDER / AUTHORISED REPRESENTATIVE				
NAME	DESIGNATION	SIGNATURE	DATE	COMPANY SEAL