



ISO  
9001:2000  
&14001:2004  
NAVARATNA  
COMPANY

**MATERIAL MANAGEMENT (PURCHASE)**  
**CENTRAL FOUNDRY FORGE PLANT, BHEL HARDWAR**  
**RANIPUR, HARIDWAR (INDIA) – 249403**  
Phone No.01334-281277/285635, FAX No. 01334-225892  
**e-mail :ranjank@bhelhwr.co.in, svn@bhelhwr.co.in**

**Sub: Tender Enquiry No: 3311P/940/2/0751H1**

Dear Sir,

We are pleased to invite offer as per enclosed specification with terms and conditions in sealed envelop for the under mentioned material.

Sl No	Tender No	Description of Material	Qty	Date & Time of Tender Opening
01	3311P/940/2/0751H1	Pneumatic Tools	810 NO's	04-02-2013 at 2.00 PM (IST)

Kindly read terms and conditions carefully. Offer not submitted in accordance with the instructions is liable to be disqualified or ignored.

Please visit [www.bhel.com](http://www.bhel.com) or [www.bhelhwr.co.in](http://www.bhelhwr.co.in) for more details and tender documents.

Please also download Supplier Registration Form and submit same dully filled.

Thanking You,

Yours Faithfully,  
For & On behalf of CFFP BHEL Hardwar

(Ranjan Kumar)  
Sr.DGM (Purchase)

**Note: Corrigendum if any shall not be published, kindly visit web-site for any changes.**

Documents attached:

1. Enquiry.
2. Annexure - I of commercial terms.
3. Annexure B of General Terms and conditions of tender enquiry.
4. Annexure IV T&C regarding Indian agent of foreign suppliers.
5. Annexure V T & C of reverse auction.
6. Annexure D for e payment format.
7. Specifications.



निविदा सूचना  
**TENDER ENQUIRY**

AA-17001

भारत हैवी इलैक्ट्रिकल्स लिमिटेड

**Bharat Heavy Electricals Ltd**

सेन्ट्रल फाउन्ड्री फॉर्ज प्लांट- हरिद्वार - २४६४०३ (भारत)

**Central Foundry Forge Plant, Haridwar-249403 (INDIA)**

Phone : (0091) 01334- 281639,281385,285336

Fax : 01334 225892 / 226458

TIN NO. 05001763485

C S T NO. HR-5018287 Dt. 16-03-1995

निविदा सूचना सं. ENQUIRY NO.*	3311.P/ 940/2/0751H1	दिनांक Date	29-12-2012
-------------------------------	----------------------	-------------	------------

कृपया निम्नलिखित के लिए निविदा दें। PLEASE QUOTE FOR THE FOLLOWING :

Office Copy

DUEDATE

04-02-2013

09285 M/s : : :

INDIA

Item Description	Quantity	Unit	Lot	Quantity	Lot Date
------------------	----------	------	-----	----------	----------

1 FF6814088029	250		NO		
----------------	-----	--	----	--	--

PORTABLE PNEUMATIC GRINDER  
SUITABLE FOR DIA 150MM WHEEL A  
S PER CLAUSE 4.1 OF SPECIFICAT  
ION.

SPEC: FF06043,REV.03 REV: ??

SIZE: -

DIM.: S

2 FF6415212907	275		NO		
----------------	-----	--	----	--	--

PNEUMATIC DIE GRINDER SUITABLE  
FOR DIA 40 WHEEL AS PER CLAUSE  
4.2 OF SPECIFICATION.

SPEC: FF06043;REV:03 REV: ??

SIZE: -

DIM.: S

3 FF6415212915	115		NO		
----------------	-----	--	----	--	--

PNEUMATIC DIE GRINDER FOR  
MOUNTED POINT, A11 SHAPE WHEEL  
SPINDLE DIA: 6 MM AS PER CLAUS  
E 4.3 OF SPECIFICATION.

SPEC: FF06043;REV:03 REV: ??

SIZE: -

DIM.: S

4 FF6415266012	20		NO		
----------------	----	--	----	--	--

PNEUMATIC ANGLE GRINDER FOR  
DCD WHEEL OD:125 X 63 THICK  
BORE DIA=16MM AS PER CLAUSE



निविदा सूचना  
**TENDER ENQUIRY**

भारत हेवी इलैक्ट्रिकल्स लिमिटेड  
**Bharat Heavy Electricals Ltd**  
सेन्ट्रल फाउन्ड्री फॉर्ज प्लांट- हरिद्वार - २४६४०३ (भारत)  
**Central Foundry Forge Plant, Haridwar-249403 (INDIA)**

AA-17001

Phone : (0091) 01334- 281639,281385,285336 Fax : 01334 225892 / 226458

TIN NO. 05001763485  
C S T NO. HR-5018287 Dt. 16-03-1995

निविदा सूचना सं. ENQUIRY NO.*	3311 P/ 940/2/0751H1	दिनांक Date	29-12-2012
-------------------------------	----------------------	-------------	------------

कृपया निम्नलिखित के लिए निविदा दें। PLEASE QUOTE FOR THE FOLLOWING :

Office Cop

SL	MATERIAL CODE	QUANTITY	UNIT	LOTNO	LOT DELIVERY QTY SCHEDULE
4	.4 OF SPECIFICATION. SPEC: FF06043;REV:03 REV: ??				
5	FF6814092018 PNEUMATIC CHIPPER FOR FLAT CHISEL AS PER CLAUSE 4.1 OF SP ECIFICATION.. SPEC: FF06044;REV:02 REV: ?? SIZE: - DIM.: S	60	NO		
6	FF6814094029 WELD FLUX CHIPPER FOR ANGLE SCALING CHISEL AS PER CL AUSE 4.2 OF SPECIFICATION. SPEC: FF06044,REV.02 REV: ?? SIZE: - DIM.: S	90	NO		

\*\* IMPORTANT: This enquiry is 2 part tender. Techno-Commercial bid (Part-1) & Price Bids (Part-2) should be submitted in separate envelopes. These two envelopes should be submitted in a common sealed envelope. Techno-Commercial Bid shall contain detailed Technical Specification, Drawings Technical documents, Catalogues, taxes & duties, payment terms, delivery period, Validity of offer, Replica of Price Bid (Copy of price bid without price part) etc. The confirmation to the special terms & conditions must be submitted alongwith Techno-Commercial bid.

Standard Instructions:  
TEST CERTIFICATE REQUIRED.  
GUARANTEE CERTIFICATE REQUIRED.  
BASIC RATES, TAXES DUTIES SEPERATELY  
CENVATABL DUPLICATE COPY OF INVOICE.

Special Instructions:  
NEW SPECIFICATION NO. FF06050 REV 00 & FF06051 REV 00 (DRAWING) ARE ENCLOSED.

- (A) VALIDITY OF OFFER SHOULD BE MIN90 DAYS FROM DATE OF OPENING.
- (B) OFFER MUST BE SUBMITTED STRICTELY IN LINE WITH SPECIFICATION, TERMS & CONDITIONS OF ENQUIRY ELSE OFFER MAY LIKELY BE IGNORED.
- (C) ALL TAXES/DUTIES/LEVIES ETC. MUST BE SPECIFIED SEPERATELY IN AMOUNT OR IN PERCENTAGE. INCOMPLETE OFFER SHALL NOT BE ACCEPTABLE.
- (D) PLEASE QUOTE ON F.O.R. DESTINATION (CFFP/BHEL), FREIGHT PRE PAID BASIS ONLY.



निविदा सूचना  
**TENDER ENQUIRY**

AA-17001

भारत हैवी इलैक्ट्रिकल्स लिमिटेड

**Bharat Heavy Electricals Ltd**

सेन्ट्रल फाउन्ड्री फॉर्ज प्लांट- हरिद्वार - २४६४०३ (भारत)

**Central Foundry Forge Plant, Haridwar-249403 (INDIA)**

Phone : (0091) 01334- 281639,281385,285336

Fax : 01334 225892 / 226458

TIN NO. 05001763485

C S T NO. HR-5018287 Dt. 16-03-1995

निविदा सूचना सं. ENQUIRY NO.*	3311 P/ 940/2/0751H1	दिनांक Date	29-12-2012
-------------------------------	----------------------	-------------	------------

कृपया निम्नलिखित के लिए निविदा दें। PLEASE QUOTE FOR THE FOLLOWING :

Office Copy

SL	MATERIAL CODE	QUANTITY	UNIT	LOTNO	LOT DELIVERY QTY SCHEDULE
----	---------------	----------	------	-------	---------------------------

- (E) IN CASE VENDOR DO NOT ACCEPT CFFP,S PAYMENT TERMS AS PER ENQUIRY PROPER LOADING SHALL BE DONE.
- (F) INSPECTION AT CFFP AS PER BASED ON TC/GC OF THE PARTY.
- (G) DULY FILLED & SIGNED WITH COMPANY SEAL"ANNEXURE-1 TO BE SUBMITTED ALONGWITH OFFER.
- (H) DELIVERY SCHEDULE (FOR DESTINATIONS - CFFP BHEL HARIDWAR)
- ITEM NO 1:- 1ST LOT 50 NOS WITHIN 60 DAYS FROM PO DATE.  
2ND LOT 200 NOS WITHIN 120 DAYS FROM PO DATE.
- ITEM NO 2:- 1ST LOT 55 NOS WITHIN 60 DAYS FROM PO DATE.  
2ND LOT 220 NOS WITHIN 120 DAYS FROM PO DATE.
- ITEM NO 3:- 1ST LOT 23 NOS WITHIN 60 DAYS FROM PO DATE.  
2ND LOT 92 NOS WITHIN 120 DAYS FROM PO DATE
- ITEM NO 4: 1ST LOT 04 NOS WITHIN 60 DAYS FROM PO DATE.  
2ND LOT 16 NOS WITHIN 120 DYAS FROM PO DATE.
- ITEM NO 5: 1ST LOT 12 NOS WITHIN 60 DAYS FROM PO DATE.  
2ND LOT 48 NOS WITHIN 120 DAYS FROM PO DATE.
- ITEM NO 6: 1ST LOT 18 NOS WITHIN 60 DAYS FROM PO DATE  
2ND LOT 72 NOS WITHIN 120 DAYS FORM PO DATE.

## General Instructions:

- Please submit authorization letter (format enclosed) for facilitating e-payment/electronic transfer of funds
  - 100% payment within 30 days after receipt & acceptance of material at CFFP BHEL, Hardwar through e-payment.
  - CFFP/BHEL RESERVES THE RIGHT TO PRE-INSPECT THE MATERIAL AT VENDOR'S WORKS / GODOWN/ PREMISES BEFORE DESPATCH.
  - ORIGINAL MANUFACTURER'S TEST CERTIFICATE IS REQUIRED ALONG WITH DESPATCH DOCUMENTS. IN CASE SUPPLIES ARE FROM TRADERS, IT SHALL BE THE RESPONSIBILITY OF THE TRADER TO PROVIDE ORIGINAL MANUFACTURER'S TEST CERTIFICATE WITH LINKAGE TO TRADER'S INVOICE STATING BATCH NO.
  - CFFP/BHEL Reserves the right to procure from more than one vendor.
  - Please quote prices in figures & words both. In case the prices quoted in words and figures are different, the values indicated in words will be considered for evaluation & establishing L1 status.
- \* The offers of the bidders who are on the banned list as also the offers of the bidders, who engage the services of the banned firms, shall be rejected. The list of banned firms is available on web site [www.bhel.com](http://www.bhel.com)

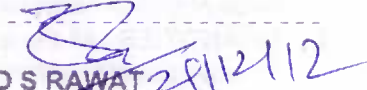
  
D S RAWAT  
ENGINEER ( PUR.)

**Commercial Terms**

Item - Pneumatic Tools

Qty - 810 Nos

Confirmation/comments on the conditions given below are mandatory. Please confirm the following or else your offer is liable to be rejected.

	<b>Description</b>	<b>Vendor Confirmation /Comment.</b>
01	Material shall be supplied as per enquiry no 3311P/940/2/0751H1 in all respects without deviation.	
02	Guarantee / Test certificate required.	
03	Delivery shall be made on FOR Destination basis, destination being Stores/CFFP/BHEL Haridwar, Freight & Insurance charges to vendor's account.	
04	Payment Term: 100% within 30 days after receipt & acceptance (commissioning) of material at CFFP / BHEL, Haridwar through e-payment. Foreign Suppliers – Payment through USANCE L/C on 70 day from B/L date.	
05	Validity of offer: Minimum 90 days from tender opening date.	
06	Prices shall be firm till execution of Order.	
07	Provide name of contact person, mobile no. & email address.	
08	LATE DELIVERY PENALTY CLAUSE (LD) : Penalty for late delivery shall be applicable @ 0.5% per week and part thereof subject to a maximum of 10% for total P.O. value (Total material cost + packing and forwarding + freight) from the date of scheduled delivery of Purchase Order.	
09	Replica of price bid (without price part) required along with offer.	
10	For new vendors who are not registered with CFFP BHEL Haridwar, duly filled up "Supplier Registration Form" (available at www.bhel.com) along-with all the supporting documents has to be submitted along-with techno-commercial bid of offer. Please confirm that SRF is being submitted with your offer if applicable. However please note that if in any case duly filled up SRF along-with all the supporting documents is not received within 15 days of tender opening, your offer will liable to be ignored.	
11	Disputes: In event of any dispute arising out of contractual obligation, the order being finalized at Haridwar, India will be subject to Indian laws and falls under jurisdiction of the court of Law at Haridwar, India. The overseas supplier hereafter referred to as "Vendor" shall therefore abide by the verdict of court of Law at Haridwar, India.	
12	BHEL will prefer to deal directly with foreign vendor/ original manufacturer. In case, vendor engages any Indian agent or take service of any Indian agent, copy of agent agreement required along with offer in line with Annexure-IV attached.	
13	a) Vendor should be manufactures or authorized dealer of equipment manufactures. Stockiest & Traders will not be considered.	
	b) Vendor must have supplied equipment (pneumatic tools) to large steel foundries during last 3 years. Order copy of foundry will be required along with the offer.	
	c) Blow up drawings of tools along with detailed parts will be required with the offer.	

	d) Detailed part list of the tools will be required along with offer.	
	e) Vendor will need to provide samples of its offered tool for trial at CFFP along with offer. The tool shall be tried for a period of 15 days in the foundry shop floor of new vendor/ new model. Based on suitability of the tool in CFFP working conditions, technical suitability of offers shall be provided.	
	f) The sample tool may be dismantled by foundry maintenance for looking into the assembly details and its maintainability.	
14	<ul style="list-style-type: none"> <li>- In case any column is left blank, it shall be deemed to be accepted by vendor.</li> <li>- If any difference is found for any term and condition in the offer and this annexure "I", the terms quoted in this annexure 'I' shall be deemed as final and binding on vendor.</li> <li>- Evaluation shall be on the basis of delivered cost (i.e.) "total cost to BHEL".</li> </ul>	

Date:

Signature with Seal of the Company.

GENERAL TERMS AND CONDITIONS OF TENDER ENQUIRY  
ANNEXURE-B

01 Submit the tender in two parts i.e.

**Part-I Techno-Commercial Bid**

**Part-II Price Bid**

Techo - Commercial (part one) Price Bid (part two) should be put in separate sealed envelopes. Both envelopes should be super scribed with **Tender Number, Date of opening & Technical / Commercial Bid and Price Bid** respectively along with name of firm.

Both the envelopes i.e. containing Techno-Commercial Bid and Price Bid should again be kept in one envelope super scribed again with Tender No. and Date of opening and the name of firm submitting the tender and send it to **AGM (MM), Purchase Department, CFFP/BHEL, Hardwar, Ranipur, Hardwar 249403, Uttarakhand, India before due date / tender opening date & time**. Normally tender opening time is 2.00 PM on due date or as mentioned in enquiry.

**Responsibility for submission of tender in time solely lies with vendor. Late offers received after specified time / Date shall not be considered.**

1. Part-I Envelopes super scribed with **Techno-Commercial Bid** must contain all information especially-
  - (a) Specification of the material offered should be strictly as per CFFP/BHEL specifications of enquired material in tender documents **Deviations if any must be indicated clearly in the offer. Rates to be quoted on For Destination Basis.**
  - (b) All commercial terms i.e. packing, forwarding Custom duty, Additional Duty, ST/STT/VAT/CST, Excise Duty/CVD. Bank charges, payment terms & insurance etc as applicable (**except price**) should be clearly mentioned in Techno-Commercial bid. Also mention present rate of applicable taxes & duties even if inclusive in rates along with the concessional forms required if any.
  - (c) Confirm to submit all required commercial documents (tax invoice centvatable duplicate copy of invoice, packing list, transit sale agreement etc.) & technical documents (TC/GC/QP etc).
  - (d) Registration Numbers of SSI, Central Excise, Sales tax, Income Tax, DGS & D.ECC etc.
  - (e) **Un-priced copy of Price Bid.**

Part-II Envelopes super scribed with Price Bid should contain priced copy of Price Bid. The price should be mentioned both in figures and words.

2. Authorized Signatory should authenticate all tender documents.
3. **Techno-commercial bid (Part-I)** will be opened on the due date at 2.00 PM in the presence of participating vendors or authorized representatives, who may wish to be present. Representative deputed to witness tender opening must produce an authority letter from the signatory of offer. After evaluation of technical bids & finalization of technical, commercial terms & conditions, price bid of only successful vendors will be opened. Priced bid opening date shall be intimated separately.
4. The material offered must conform to the required BHEL specifications and drawings as well as instructions and details made available.
5. For new vendors, Vendor Registration from duly filled must be submitted along with the offer which can be downloaded from our web site [www.bhel.com](http://www.bhel.com) or [www.bhelhwr.co.in](http://www.bhelhwr.co.in).
6. Original manufacturer's Test Certificate is required along with dispatch documents. In case supplies are from traders, it shall be the responsibility of the trader to provide original manufacture's test certificate with linkage to traders invoice stating batch no.
7. **Validity** of offers should be minimum 90 working days from the date of tender (Techno-Commercial Bid) opening.

8. **Delivery** in the promised period is the essence of contract. Confirm to supply according to delivery schedule mentioned.
9. **Payment terms:**  
For indigenous suppliers: 100% within 30 days after receipt & acceptance of material at CFFP / BHEL, Haridwar through e-payment.  
For foreign suppliers: Payment through USANCE LC on 70<sup>th</sup> day of bill of lading date. All bank charges shall be to vendor's account.  
  
\* In case vendor does not agree, proper loading shall be done. Also in that case, third party inspection shall have to be arranged by supplier from any of the five inspection agencies namely: LRS/ BVQI/ DNV/ TUV/ Alfred H Knight at their cost.
10. CFFP/BHEL, Hardwar reserves the right to accept or reject any or all tenders without assigning any reason thereof.
11. Tenders not submitted in the prescribed manner are likely to be ignored / rejected.
12. Agent/Agency Commissioning: Payment of any kind at any stage will not be made to agent on account of agent commission or otherwise by CFFP/BHEL, Hardwar.
13. CFFP/BHEL, Hardwar may opt for E-auction/Reverse auction for obtaining best prices for part or full tendered quantity. BHEL also reserve the right to negotiate price with L1 vendor after reverse auction.
14. Please do intimate the personal contact details like Name, Mobile Number, Email-id etc of authorized executive for correspondence.
15. **Penalty:** Orders placed against this enquiry will be subject to normal clauses for imposing penalty. Liquidated Damages, Risk purchases, cancellation, arbitration as per terms and conditions of Tender Enquiry and Purchase orders in case of delay in effecting supply and/ or other defaults.  
**Liquidated damage:** The delivery of the goods shall be made strictly as per time limit specified in delivery schedule, failure to supply within this period will make the supplier liable to an conditional penalty of 1/2 (half) percent of the price of the goods in arrears per week subject to a maximum of 10%.
16. **Inspection:** Final inspection of material shall be done after receipt of material at CFFP/BHEL, Hardwar. Acceptance of material shall be after final inspection and shall be binding. However, CFFP reserves the right to pre Inspect the material at supplier works. In case material is found defective during warranty period, the same will be returned for repair and/ or replacement. For this vendor has to bear all the charges such as Freight, to and fro insurance etc. Bank Guarantee for the equal amount to the cost of the item is to be furnished by vendor. In case the repair is done at CFFP/BHEL the amount on actual shall have to be reimbursed by the Vendor and or adjusted on actual from their bill.
17. **Currency of Payment:** Mention the currency in which payment has to be made. For evaluation of price bids, exchange rate (TT selling rate of SBI) as on scheduled date of tender opening (Part-1 bid in case of two part bid) shall be considered.
18. Traders should submit authorization letter from their principal alongwith offer.
19. Disputes: In event of any dispute arising out of contractual obligation, the order being finalized at Hardwar, India will be subject to Indian Laws and falls under jurisdiction of the court of Law at Haridwar, India. The overseas supplier hereafter referred to as "Vendor" shall therefore abide by the verdict of Court of Law at Hardwar, India.  
OR  
All disputes arising out of or in connection with the present contract, if any shall be finally settled under the rules of arbitration of International chamber of commerce by one or more arbitrator appointed in accordance with the said Rules in India.
20. BHEL reserves the right to place P.O. for part / full qty and on one or more than one sources.
21. Any Term & condition of the specific tender (if specified in tender & contradicts with above term) will supersede the above general terms & conditions.

**Terms and conditions regarding Indian agent of foreign suppliers:**

01. BHEL shall deal directly with foreign vendors, wherever required, for procurement of goods. However, if the foreign principal desires to avail of the services of an Indian agent, then the foreign principal should ensure compliance to regulatory guidelines- which require mandatory submission of an Agency agreement.
02. It shall be incumbent on the Indian agent and the foreign principal to adhere to the relevant guidelines of Government of India, issued from time to time.
03. The agency agreement should specify the precise relationship between the foreign OEM/Foreign principal and their Indian agent and their mutual interest in the business. All services to be rendered by agent/associate, whether of general nature or in relation to the particular contract, must be clearly stated by the foreign supplier / Indian agent. Any payment, which the agent or associate receives in India or aboard from the OEM, whether as commission or as a general retainer fee should be brought on record in the agreement and be made explicit in order to ensure compliance to laws of the country.
04. Any agency commission to be paid by BHEL to the Indian agent shall be in Indian currency only.
05. Tax deduction at source is applicable to the agency commission paid to the Indian agent as per the prevailing rules.
06. In the absence of any agency agreement, BHEL shall not deal with any Indian agent (authorized representatives/ associate/consultant, or by whatever name called) and shall deal directly with the foreign principal only for all correspondence and business purposes.
07. The "Guidelines for Indian Agents of Foreign Suppliers" enclosed at annexure- 'A' shall apply in all such cases.
08. The supply and execution of the Purchase Order (including indigenous suppliers/service) shall be in the scope of the OEM/ Foreign principal. The OEM/ Foreign principal should submit their offer inclusive of all indigenous suppliers/services and evaluation will be based on 'total cost to BHEL'. In case OEM/ foreign principal recommends placement of order(s) towards indigenous portion of supplies/services on Indian Supplier (s)/ agent on their behalf, the credentials/capacity/capability of the Indian Supplier (s)/ agent to make the supplies/Services shall be checked by BHEL as per the extant guidelines of Supplier Evaluation, Approval and Review Procedure (SEARP), before opening of price bids. In this regards, details may be checked as per Annexure- 'B' (copy enclosed). It will be the responsibility of the OEM/ Foreign Principal to get acquainted with the evaluation requirements of Indian supplier/agent as per SEARP available on [www.bhel.com](http://www.bhel.com).

The responsibility for successful execution of the contract (including indigenous supplies/services) lies with the OEM/ foreign principal. All bank guarantees to this effect shall be in the scope of the OEM/Foreign principal.

**Guidelines for Indian Agents of Foreign Suppliers**

- 1.0 There shall be compulsory registration of agents for all Global (Open) Tender and Limited Tender. An agent who is not registered with BHEL shall apply for registration in the registration form in line with SEARP.
  - 1.1 Registered agents will file an authenticated Photostat copy duly attested by a Notary Public/Original certificate of the Principal confirming the agency agreement and giving the status being enjoyed by the agent and the commission/ remuneration/ salary/ retainership being paid by the principal to the agent before the placement of order by BHEL.
  - 1.2 Wherever the Indian representatives have communicated on behalf of their principals and the foreign parties have stated that they are not paying any commission to the Indian agents, and the Indian representative is working on the basis of salary or as retainer, a written declaration to this effect should be submitted by the party (i.e. Principal) before finalizing the order.
- 2.0 Disclosure of particulars of agents/ representatives in India, if any.**
- 2.1 Tenderers of Foreign nationality shall furnish the following details in their offers:
    - 2.1.1 The Bidder(s)/ Contractor(s) of foreign origin shall disclose the name and address of the agents/ representatives in India if any and the extent of authorization and authority given to commit the Principals. In case the agent/ representative be a foreign Company, it shall be confirmed whether it is existing Company and details of the same shall be furnished.
    - 2.1.2 The amount of commission/ remuneration included in the quoted price(s) for such agents/ representatives in India.
    - 2.1.3 Confirmation of the Tenderer that the commission/ remuneration, if any, payable to his agents/ representatives in India, may be paid by BHEL in Indian Rupees only.
  - 2.2 Tenderers of Indian Nationality shall furnish the following details in their offers:
    - 2.2.1 The Bidder(s)/ Contractor(s) of Indian Nationality shall furnish the name and address of the foreign principals, if any, indicating their nationality as well as their status, i.e. whether manufacturer or agents of manufacturer holding the Letter of Authority of the Principal specifically authorizing the agent to make an offer in India in response to tender either directly or through the agents/ representatives.
    - 2.2.2 The amount of commission/ remuneration included in the price (s) quoted by the Tenderer for himself.
    - 2.2.3 Confirmation of the foreign principals of the Tenderer that the commission/ remuneration, if any, reserved for the Tenderer in the quoted price(s), may be paid by BHEL in India in equivalent Indian Rupees on satisfactory completion of the Project or supplies of Stores and Spares in case of operation items.
  - 2.3 In either case, in the event of contract materializing, the terms of payment will provide for payment of the commission/ remuneration, if any payable to the agents/ representatives in India in Indian Rupees on expiry of 90 days after the discharge of the obligations under the contract.
  - 2.4 Failure to furnish correct and detailed information as called for in paragraph 2.0 above will render the concerned tender liable to rejection or in the event of a contract materializing, the same liable to termination by BHEL. Besides this there would be a penalty of banning business dealings with BHEL or damage or payment of a named sum.

---X---

This format is applicable only to Indian Suppliers/ Agents supplying indigenous portion of Foreign Purchases.

\* In all other cases, extant guidelines of SEARP, 2010 are to be followed.

SEARP (SRF) Clause No	Detail
	<b>Name &amp; address of the firm</b>
<b>1.0</b>	<b>Products/ Systems / Services being considered for</b>
<b>2.0</b>	<b>General Information</b>
2.2	Name of Chief Executive
2.3	Details of authorized signatory
<b>3.0</b>	<b>Ownership Information</b>
3.1	Type of firm
3.2	Nature of Business <ul style="list-style-type: none"> <li>• <i>Attach <b>authorization letter</b> and <b>agency agreement</b> from Principal ( from whom capital equipment is procured)</i></li> <li>• <i>Attach copy of declaration from Foreign Principal for <b>total guarantee/ warranty of indigenous supplies</b></i></li> </ul>
3.3	Year of establishment
3.4	Year of commencement of business
<b>4.0</b>	<b>Registration particulars</b>
4.1	Permanent Account No.
4.2 / 4.3	Sales Tax / TIN no
4.6	Service tax no. (in case of E&C)
<b>5.0</b>	<b>Organisational strength</b>
<b>6.0</b>	<b>Other particulars</b>
6.1	If the company is already registered with other units
6.2	Directors/ Partners, if related to any BHEL Employee
6.9	If any Ex BHEL Personnel employed by the Company
6.12	Details of pending legal issues with BHEL
6.13	Bank Account information
<b>9.0</b>	<b>Financial information</b>
9.6	Sales/ Turnover details of last 3 years (or from the date of incorporation whichever is less )

---X---

**GENERAL TERMS AND CONDITIONS OF REVERSE AUCTIONING**

Against this enquiry for the subject item /system with detailed scope of supply as per enquiry specifications, BHEL may resort to “REVERSE AUCTION PROCEDURE” i.e., ON LINE BIDDING ON INTERNET.

1. For the proposed reverse auction, technically and commercially acceptable bidders only shall be eligible to participate.
2. BHEL will engage the services of a service provider who will provide all necessary training and assistance before commencement of on line bidding on internet.
3. BHEL will inform the vendor in writing in case of reverse auction, the details of Service Provider to enable them to contact & get trained.
4. Business rules like event date, time, start price, bid decrement, extensions etc. also will be communicated through service provider for compliance.
5. Vendors have to fax the Compliance form in the prescribed format (provided by Service provider) before start of Reverse auction. Without this, the vendor will not be eligible to participate in the event.
6. BHEL will provide the calculation sheet (e.g., EXCEL sheet) which will help to arrive at “Total Cost to CFFP/BHEL” basis which covers all parameters of specification and commercial terms for each of the vendor to enable them to fill-in the price and keep it ready for keying in during the Auction.
7. Reverse auction will be conducted on scheduled date & time.
8. At the end of Reverse Auction event, the lowest bidder value will be known on the network.
9. The lowest bidder has to Fax the duly signed Filled-in prescribed format as provided on case-to-case basis to BHEL through Service provider within 24 hours of Auction without fail.
10. Any variation between the on-line bid value and the signed document will be considered as sabotaging the tender process and will invite disqualification of vendor to conduct business with BHEL as per prevailing procedure.
11. In case BHEL decides not to go for Reverse Auction procedure for this tender enquiry, the Price bids and price impacts, if any, already submitted and available with BHEL shall be opened as per BHEL’s standard practice.

AUTHORISATION LETTER  
FOR E-PAYMENT/ELECTRONIC FUNDS TRANSFER (EFT/RTGS)  
PLEASE FILL UP THE FORM IN CAPITAL LETTERS ONLY

ANNEXURE-D  
Page 1 of 1

TYPE OF REQUEST (Tick One)	<input type="checkbox"/>	CREATE	<input type="checkbox"/>	CHANGE
<hr/>				
BHEL Vendor/ Supplier Code	<input type="text"/>			
Company's Name	<input type="text"/>			
Address	<input type="text"/>			
	<input type="text"/>			
City	<input type="text"/>			
Pincode	<input type="text"/>			
State	<input type="text"/>			
<hr/>				
Contact Person(S)	<input type="text"/>			
Telephone NO.	<input type="text"/>			
FAX. No.	<input type="text"/>			
e-mail id	<input type="text"/>			
<hr/>				
1. Bank Name	<input type="text"/>			
2. Bank Address	<input type="text"/>			
	<input type="text"/>			
3. Bank Telephone No.	<input type="text"/>			
4. Bank Account No.	<input type="text"/>			
5. Account Type.	<input type="text"/>			
6. Bank's Branch Code	<input type="text"/>			
7. Bank Swift Code	<input type="text"/>			
(aplicable to EFT only)				
8. Enclose blank cancelled cheque	<input type="checkbox"/>	<input type="checkbox"/>		

DECLARATION

1. I as representative/Owner of the above named company, hereby authorize BHEL CFFP, Ranipur, Haridwar to electronically make payments to the designated bank account. I hereby certify that the particulars given above are true, complete and correct.  
(2) If the transsation is delayed or not effected at all for reasons of incomplete or incorrect information, I would not hold BHEL/transfereing Bank responsible.
3. This authority remains in full force untill BHEL, CFFP, Ranipur, Haridwar receives & acknowledge written notification requesting a change or cancellation.
4. I have read the contents of the covering letter and agree to discharge the responsibilty expected of me as a participant under E-payment/EFT/RTGS.

Date:

Authorized Signatory  
Designation

Company Seal

Verification By Bank





संस्थान क्रय विनिर्देश (सी.एफ.एफ.पी. - हरिद्वार)

FF 06043 Rev 03

PLANT PURCHASE SPECIFICATION  
(CFFP - HARDWAR)

पृष्ठ का  
Page 2 of 3

आमंत्रण पत्र पर  
SIGN & DATE

आवृत्ति एवं शर्तों  
INSTRUCTIONS - NO.  
के अधीन कार्य करें

CONFIDENTIAL AND CONFIDENTIAL  
The information on this document is the property of Bharat Heavy Electrical Limited. It must not be used directly or indirectly in any way detrimental to the interest of the Company.

संस्थाधिकार एवं गोपनीयता का अर्थ है कि यह दस्तावेज केवल  
आवृत्ति एवं शर्तों के अधीन कार्य करने के लिए ही प्रयोग किया जा सकता है।  
इस दस्तावेज को प्रकटित करने से बचना चाहिए।

आमंत्रण पत्र पर  
SIGN & DATE

आवृत्ति एवं शर्तों  
INSTRUCTIONS - NO.  
के अधीन कार्य करें

5. MISCELLANEOUS

- 5.1 The grinder shall work efficiently in the air pressure range of 4 Kg/cm<sup>2</sup> to 7 Kg/cm<sup>2</sup>. All the grinders should have metallic body and suitable for manual working.
- 5.2 Demonstration of pneumatic grinder and shop trial at CFFP works are required for consideration of new vendors/models.
- 5.3 The supply shall include the following:
  - a) Spares for 2 years trouble-free service.
  - b) Detailed information about spares.
  - c) Safety and maintenance manual.
  - d) Suppliers address for procurement of spares.
  - e) Test and guarantee certificates.

6. INSPECTION AND REPLACEMENT

- 6.1 BHEL reserves the right to inspect material at site before despatch. The supplier shall intimate in advance about readiness of material enclosing a copy of test certificate of the material offered for inspection. However inspection at BHEL shall be final. The supplier shall offer BHEL representative all reasonable test facilities without charge to satisfy the latter that the material being furnished is in accordance with this specification. The supplier shall prepare and provide necessary test specimens for testing to be carried out at his premises. If facilities are not available at his works, the supplier shall make necessary arrangements for carrying out the prescribed tests elsewhere.
- 6.2 If the tools received at CFFP is not found in accordance with the requirements or it falls during guarantee period, it shall be rejected and the supplier will have to replace it free of cost at the earliest.

7. TEST CERTIFICATES

- 7.1 Unless otherwise specified, one original and three copies of test certificate from the original manufacturer shall be supplied with each consignment bearing the following information. In order to facilitate quick clearance of material, the supplier shall ensure to send a copy of test certificate along with despatch document.
  - a. BHEL PO No. with Date
  - b. Specification No.
  - c. Supplier reference / trade mark
  - d. Identification No. / Batch No.
  - e. Characteristics as per Clause 4
  - f. Any other specific information which the supplier would like to convey.
- 7.2 Suppliers other than the original manufacturer shall ensure providing original manufacturer's test certificates with linkage to supplier's invoice stating the batch No., lot No., etc of the supply.

7. MARKING & PACKING

The pneumatic tools should be suitably packed to avoid damage during transit and storage. The packing should be that of the original manufacturer. Each tool should have model No, Identification No. (if any) marked on the tool.

निष्पन्नकर्ता WORKED BY	T DAVE		
जांचकर्ता CHECKED BY	AKC		

निर्देशक एवं हस्ताक्षर SIGN & DATE:		<b>क्रय विनिर्देश (सी.एफ.एफ.पी. - हरिद्वार)</b> <b>PURCHASE SPECIFICATION</b> <b>(CFPP - HARDWAR)</b>		<b>FF06050 Rev 00</b> पृष्ठ का Page 1 of 3											
		SUPERSEDES INVENTORY NO सामग्री सूची संख्या को अधिष्ठाता द्वारा	<b>PORTABLE PNEUMATIC GRINDERS</b>												
<b>1. GENERAL</b>															
This specification governs the requirements of <b>Portable Pneumatic Hand Grinders</b> for use in foundries.															
<b>2. APPLICATION</b>															
Resinoid Grinding wheels of different sizes shall be mounted on these grinders for heavy duty grinding work on steel castings and smoothing of weldments.															
<b>3. COMPLIANCE WITH NATIONAL STANDARD</b>															
There is no national standard available.															
<b>4. CHARACTERISTICS</b>															
The different types of grinders alongwith their suitability is described below:															
<table border="1" style="width: 100%; border-collapse: collapse;"> <thead> <tr> <th style="width: 10%;">Sl. No.</th> <th style="width: 90%;">Description</th> </tr> </thead> <tbody> <tr> <td>4.1</td> <td>Pneumatic steel clad grinders, alongwith suitable attachments for mounting of grinding wheels of <math>\phi 150\text{mm} \times 25\text{mm} \times \phi 16\text{mm}</math> bore, and DCD wheels <math>\phi 180\text{mm} \times 7\text{mm} \times \phi 22.23\text{mm}</math> bore</td> </tr> <tr> <td>4.2</td> <td>Pneumatic Die grinder suitable for mounting grinding wheel of <math>\phi 40\text{mm} \times 20\text{mm} \times 10</math> Bore and Nut inserted wheel of <math>\phi 45\text{mm} \times \text{HT } 60\text{mm} \times \text{M10}</math> nut. Collet attachment for this is to be supplied.</td> </tr> <tr> <td>4.3</td> <td>Pneumatic Die grinder alongwith suitable collet attachments for mounted point A11 shape wheel</td> </tr> <tr> <td>4.4</td> <td>Pneumatic angle grinder alongwith necessary attachments, suitable for wheels of size: DCD wheel – OD 230mm x Thickness 3mm x Bore 22.23mm, Straight cup grinding wheel OD125mm x Thickness 63mm x Bore 16mm</td> </tr> </tbody> </table>						Sl. No.	Description	4.1	Pneumatic steel clad grinders, alongwith suitable attachments for mounting of grinding wheels of $\phi 150\text{mm} \times 25\text{mm} \times \phi 16\text{mm}$ bore, and DCD wheels $\phi 180\text{mm} \times 7\text{mm} \times \phi 22.23\text{mm}$ bore	4.2	Pneumatic Die grinder suitable for mounting grinding wheel of $\phi 40\text{mm} \times 20\text{mm} \times 10$ Bore and Nut inserted wheel of $\phi 45\text{mm} \times \text{HT } 60\text{mm} \times \text{M10}$ nut. Collet attachment for this is to be supplied.	4.3	Pneumatic Die grinder alongwith suitable collet attachments for mounted point A11 shape wheel	4.4	Pneumatic angle grinder alongwith necessary attachments, suitable for wheels of size: DCD wheel – OD 230mm x Thickness 3mm x Bore 22.23mm, Straight cup grinding wheel OD125mm x Thickness 63mm x Bore 16mm
Sl. No.	Description														
4.1	Pneumatic steel clad grinders, alongwith suitable attachments for mounting of grinding wheels of $\phi 150\text{mm} \times 25\text{mm} \times \phi 16\text{mm}$ bore, and DCD wheels $\phi 180\text{mm} \times 7\text{mm} \times \phi 22.23\text{mm}$ bore														
4.2	Pneumatic Die grinder suitable for mounting grinding wheel of $\phi 40\text{mm} \times 20\text{mm} \times 10$ Bore and Nut inserted wheel of $\phi 45\text{mm} \times \text{HT } 60\text{mm} \times \text{M10}$ nut. Collet attachment for this is to be supplied.														
4.3	Pneumatic Die grinder alongwith suitable collet attachments for mounted point A11 shape wheel														
4.4	Pneumatic angle grinder alongwith necessary attachments, suitable for wheels of size: DCD wheel – OD 230mm x Thickness 3mm x Bore 22.23mm, Straight cup grinding wheel OD125mm x Thickness 63mm x Bore 16mm														
<b>5. MISCELLANEOUS</b>															
<b>5.1</b> The grinders should be able to work efficiently in the air pressure range of $4\text{ Kg/cm}^2$ to $7\text{ Kg/cm}^2$ . All the grinders should have metallic body and suitable for manual working under conditions of high dust and fumes associated with steel foundries.															
हस्ताक्षर एवं दिनांक	अनुवादक		TRANSLATED BY												
	निर्माणकर्ता		WORKED BY		L Agrawal										
सामग्री सूची संख्या INVENTORY	जांचकर्ता		CHECKED BY		Tushar Dave										
	अनुमोदित		APPROVED BY		Tushar Dave										
स्वत्वधिकार एवं गोपनीयता इस प्रलेख में दी गई सूचना भारत रेली इंजीनियरिंग कॉर्पोरेशन की सम्पत्ति है। इसका प्रत्यक्ष एवं अप्रत्यक्ष रूप से किसी भी तरह प्रयोग, जो कि कंपनी के हित में हानिकारक हो सके बिना जाए।		स्वीकृति : APPROVED :		तैयार : फाउण्ड्री तकनीकी PREPARED : FOUNDRY TECH											
		जारी : फाउण्ड्री तकनीकी ISSUED : FOUNDRY TECHNOLOGY		दिनांक : DATE : 24.07.12											

2



क्रय विनिर्देश (सी.एफ.एफ.पी. - हरिद्वार)  
**PURCHASE SPECIFICATION**  
 (CFFP - HARDWAR)

FF 06050 Rev 00

पृष्ठ का  
 Page 2 of 3

हस्ताक्षर एवं दिनांक  
SIGN & DATE

SUPERSEDES  
INVENTORY NO

सामग्री सूची  
को संश्लेषित करना

COPYRIGHT AND CONFIDENT

The information on this documents is the property of Bharat Heavy Electricals Limited. It must not be used directly or indirectly in any way detrimental to the interest of the company.

स्वतंत्राधिकार एवं गोपनीयता  
हस्ताक्षर एवं दिनांक  
SIGN & DATE

हस्ताक्षर एवं दिनांक  
SIGN & DATE

सामग्री सूची  
संख्या

5.2 Demonstration of pneumatic grinder and shop trial at CFFP works are required for consideration of new vendors/models. Alongwith the offer, the vendor shall submit his tools on returnable basis, which shall be tried at shopfloor for a period of 15 days. No extra charges shall be paid for the trial period. The tool may also be dismantled for study of the internal components from maintenance point of view. Blow-up drawings of tools alongwith detailed parts will be required with the offer. Technical acceptance of the offer shall be given based on the trials conducted at CFFP.

5.3 The offer should include list of spares required for 2 year trouble-free operation. Cost of spares should be mentioned separately. Cost of spares shall not be considered in evaluation of tool price.

5.4 The supply shall include the following:  
 a) Safety and maintenance manual.  
 b) Test and guarantee certificates.

6. INSPECTION AND REPLACEMENT

6.1 BHEL reserves the right to inspect material at site before despatch. The supplier shall intimate in advance about readiness of material enclosing a copy of test certificate of the material offered for inspection. However inspection at BHEL shall be final. The supplier shall offer BHEL representative all reasonable test facilities without charge to satisfy the latter that the material being furnished is in accordance with this specification. The supplier shall prepare and provide necessary test specimens for testing to be carried out at his premises. If facilities are not available at his works, the supplier shall make necessary arrangements for carrying out the prescribed tests elsewhere.

6.2 If the tools received at CFFP is not found in accordance with the requirements or it fails during guarantee period, it shall be rejected and the supplier will have to replace it free of cost at the earliest.

7. TEST CERTIFICATES

7.1 Unless otherwise specified, one original and three copies of test certificate from the original manufacturer shall be supplied with each consignment bearing the following information. In order to facilitate quick clearance of material, the supplier shall ensure to send a copy of test certificate along with despatch document.

- a. BHEL PO No. with Date
- b. Specification No.
- c. Supplier reference / trade mark
- d. Identification No. / Batch No.
- e. Characteristics as per Clause 4
- f. Any other specific information which the supplier would like to convey.

7.2 Suppliers other than the original manufacturer shall ensure providing original manufacturer's test certificates with linkage to supplier's invoice stating the batch No., lot No., etc of the supply.

8. MARKING & PACKING

The pneumatic tools should be suitably packed to avoid damage during transit and storage. The packing should be that of the original manufacturer. Each tool should have model No, Identification No. (if any) marked on the tool.

निर्माणकर्ता WORKED BY	L Agrawal		25/07/12
जांचकर्ता CHECKED BY	T Dave		25/07/12

दिनांक एवं पंजीकरण SIGN & DATE		<b>क्रय विनिर्देश (सी.एफ.एफ.पी. - हरिद्वार)</b>  <b>PURCHASE SPECIFICATION</b> (CFFP - HARDWAR)	<b>FF06051 Rev 00</b>  पृष्ठ का Page 1 of 5						
शीर्षक संख्या (अ) अधिकृतता कक्षा  SUPERSEDES INVENTORY NO.	<b><u>PORTABLE PNEUMATIC CHIPPERS</u></b>								
शीर्षक संख्या (अ) अधिकृतता कक्षा  COPYRIGHT AND CONFIDENTIAL The information on this document is the property of Bharat Heavy Electricals Limited. It must not be used directly or indirectly in any way detrimental to the interest of this company.	<b>1. GENERAL</b>  This specification governs the requirements of <b>Portable Pneumatic Chippers</b> for use in foundries.								
शीर्षक संख्या (अ) अधिकृतता कक्षा	<b>2. APPLICATION</b>  Pneumatic chippers shall be fitted with forged chisels for cleaning sand from steel castings and cleaning slag from weld deposits.								
शीर्षक संख्या (अ) अधिकृतता कक्षा	<b>3. COMPLIANCE WITH NATIONAL STANDARD</b>  There is no national standard available.								
शीर्षक संख्या (अ) अधिकृतता कक्षा	<b>4. CHARACTERISTICS</b>  The different types of chippers alongwith their suitability is described below:								
<table border="1" style="width:100%; border-collapse: collapse;"> <thead> <tr> <th style="width:10%;">Sl. No.</th> <th>Description</th> </tr> </thead> <tbody> <tr> <td>4.5</td> <td>Heavy duty pneumatic chippers [to be fitted with forged chisels with hexagonal shank as per Drg No. FT-11-93]</td> </tr> <tr> <td>4.6</td> <td>Pneumatic weld flux chipper [to be fitted with forged angle scaling chisel as shown in Drg No. FT-11-90]</td> </tr> </tbody> </table>				Sl. No.	Description	4.5	Heavy duty pneumatic chippers [to be fitted with forged chisels with hexagonal shank as per Drg No. FT-11-93]	4.6	Pneumatic weld flux chipper [to be fitted with forged angle scaling chisel as shown in Drg No. FT-11-90]
Sl. No.	Description								
4.5	Heavy duty pneumatic chippers [to be fitted with forged chisels with hexagonal shank as per Drg No. FT-11-93]								
4.6	Pneumatic weld flux chipper [to be fitted with forged angle scaling chisel as shown in Drg No. FT-11-90]								
शीर्षक संख्या (अ) अधिकृतता कक्षा	<b>5. MISCELLANEOUS</b>								
शीर्षक संख्या (अ) अधिकृतता कक्षा	<b>5.1</b> The chippers should be able to work efficiently in the air pressure range of 4 Kg/cm <sup>2</sup> to 7 Kg/cm <sup>2</sup> . All the chippers should have metallic body and suitable for manual working under conditions of high dust and fumes usually associated with steel foundries.								
शीर्षक संख्या (अ) अधिकृतता कक्षा	<b>5.2</b> Demonstration of pneumatic chipper and shop trial at CFFP works are required for consideration of new vendors/models. Alongwith the offer, the vendor shall submit his tools on returnable basis, which shall be tried at shopfloor for a period of 15 days. No extra charges shall be paid for the trial period. The tool may also be dismantled for study of the internal components from maintenance point of view.								
शीर्षक संख्या (अ) अधिकृतता कक्षा	<b>5.3</b> The offer should include list of spares required for 2 year trouble-free operation and its cost to be provided separately. The cost of spares shall not be considered in evaluation of tool price.								
शीर्षक संख्या (अ) अधिकृतता कक्षा	<b>5.4</b> The supply shall include the following: a) Safety and maintenance manual. b) Test and guarantee certificates.								
शीर्षक संख्या (अ) अधिकृतता कक्षा	अनुवादक TRANSLATED BY	निर्माणकर्ता WORKED BY	जासे : फाउण्ड्री टेक्नालॉजी ISSUED : FOUNDRY TECHNOLOGY						
शीर्षक संख्या (अ) अधिकृतता कक्षा	जांचकर्ता CHECKED BY	Tushar Dave	दिनांक DATE: 24.7.12						
शीर्षक संख्या (अ) अधिकृतता कक्षा	Approved By	Tushar Dave							
शीर्षक संख्या (अ) अधिकृतता कक्षा	निर्माण : PREPARED : FOUNDRY TECH	जारी : फाउण्ड्री टेक्नालॉजी ISSUED : FOUNDRY TECHNOLOGY	दिनांक DATE: 24.7.12						

स्वतंत्रता और गोपनीयता इस प्रलेख में दी गई सूचना भारत  
 की सुरक्षा के लिए है। इसका प्रयोग एवं प्रसारण के बिना  
 की अनुमति के बिना कहीं भी किया जाये।



**क्रय विनिर्देश (सी.एफ.एफ.पी. - हरिद्वार)**  
**PURCHASE SPECIFICATION**  
**(CFFP - HARDWAR)**

FF 06051 Rev 00

पृष्ठ का  
 Page 2 of 5

**6. INSPECTION AND REPLACEMENT**

6.1 BHEL reserves the right to inspect material at site before despatch. The supplier shall intimate in advance about readiness of material enclosing a copy of test certificate of the material offered for inspection. However inspection at BHEL shall be final. The supplier shall offer BHEL representative all reasonable test facilities without charge to satisfy the latter that the material being furnished is in accordance with this specification. The supplier shall prepare and provide necessary test specimens for testing to be carried out at his premises. If facilities are not available at his works, the supplier shall make necessary arrangements for carrying out the prescribed tests elsewhere.

6.2 If the tools received at CFFP is not found in accordance with the requirements or it fails during guarantee period, it shall be rejected and the supplier will have to replace it free of cost at the earliest.

**7. TEST CERTIFICATES**

7.1 Unless otherwise specified, one original and three copies of test certificate from the original manufacturer shall be supplied with each consignment bearing the following information. In order to facilitate quick clearance of material, the supplier shall ensure to send a copy of test certificate along with despatch document.

- a. BHEL PO No. with Date
- b. Specification No.
- c. Supplier reference / trade mark
- d. Identification No. / Batch No.
- e. Characteristics as per Clause 4
- f. Any other specific information which the supplier would like to convey.

7.2 Suppliers other than the original manufacturer shall ensure providing original manufacturer's test certificates with linkage to supplier's invoice stating the batch No., lot No., etc of the supply.

**7. MARKING & PACKING**

The pneumatic tools should be suitably packed to avoid damage during transit and storage. The packing should be that of the original manufacturer. Each tool should have model No, Identification No. (if any) marked on the tool.

हस्ताक्षर एवं तिनांक  
 SIGN & DATE

सुपर्सिडस  
 INVENTORY NO.

सामग्री सूची संख्या  
 आ क्रिकमिड संख्या

**COPYRIGHT AND CONFIDENTIAL**  
 The information on this document is the property of Bharat Heavy Electricals Limited. It must not be used directly or indirectly in any way detrimental to the interest of the company.

**स्वत्वाधिकार एवं गोपनीयता**  
 इस दस्तावेज की सम्पत्ति है। इसका प्रयोग एवं आरक्षण केवल सी.एफ.एफ.पी. ही करे प्रयोग, जो कि कंपनी के हित में अधिकारक ही न किया जाए।

हस्ताक्षर एवं तिनांक  
 SIGN & DATE

सामग्री सूची संख्या

निर्मणकर्ता WORKED BY	L Agrawal	<i>Pant</i>	<i>22/07/12</i>
जांचकर्ता CHECKED BY	T Dave	<i>T Dave</i>	<i>22/07/12</i>

रिमांक एवं हार्डवार नंबर  
- ४-१०२



क्रय विनिर्देश (सी.एफ.एफ.पी.-हरिद्वार)

FF 06051 Rev 00

**PURCHASE SPECIFICATION**  
(CFFP - HARDWAR)

पृष्ठ का  
Page 3 of 5

सुपरसेडि इन्वेंट्री नंबर

सामग्री की संख्या  
की ओर इशारा करना

**COPYRIGHT AND CONFIDENTIAL**

The information on this document is the property of Bharat Heavy Electricals Limited. It must not be used directly or indirectly in any way detrimental to the interest of the company.

स्वत्वाधिकार एवं गोपनीयता  
हम प्रत्येक में दी गई सूचना मानते हैं।  
किसी भी प्रकार पर अनाधिकार रूप से किसी भी तरह प्रयोग, जो कि  
कंपनी के हित में हानिकारक हो न किया जाए।

हस्ताक्षर एवं रिमांक  
SIGN & DATE

सामग्री की  
संख्या

ALL DIMENSIONS ARE IN INCHES

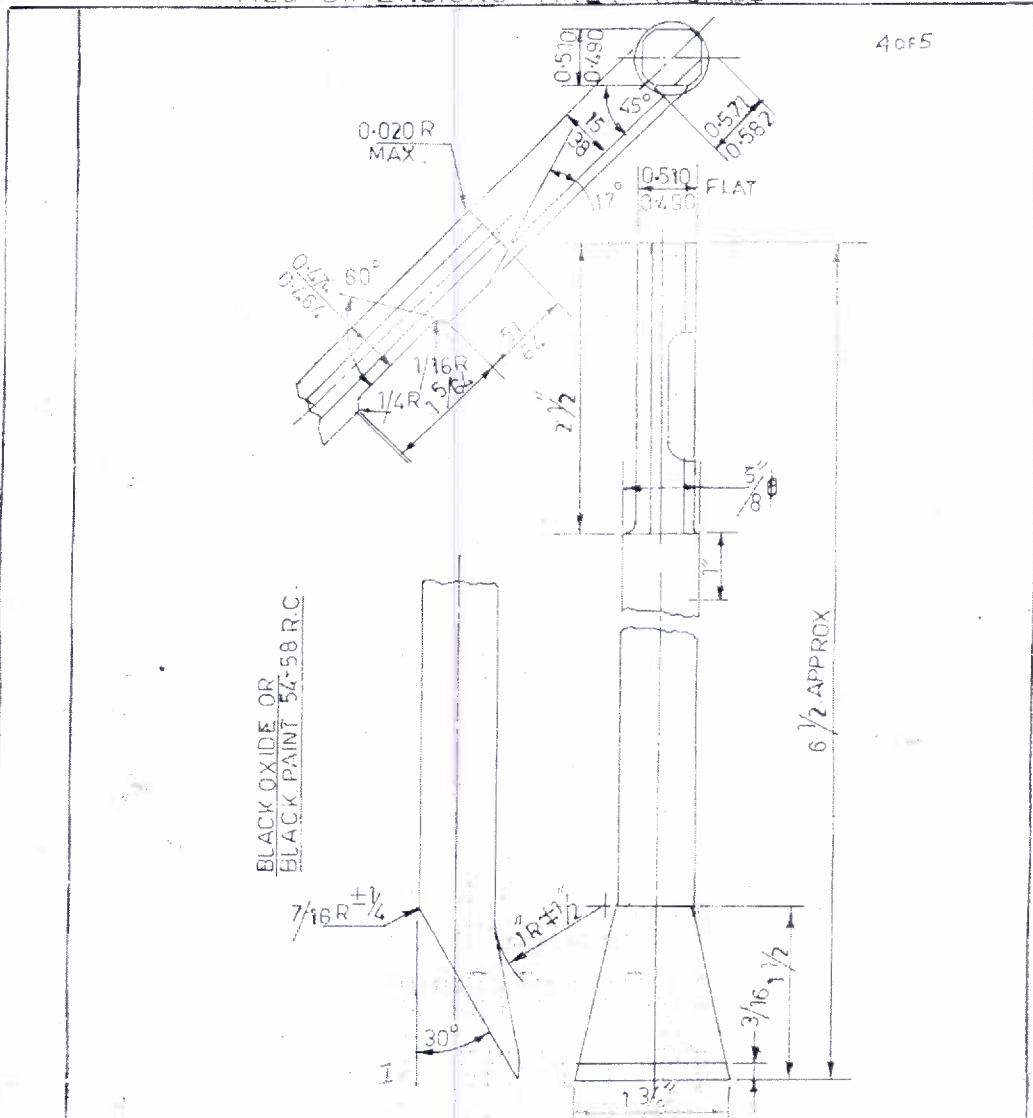

4 of 5



**BHARAT HEAVY ELECTRICALS LTD.**  
UNIT: CENTRAL FOUNDRY FORGE PLANT.  
HARDWAR.

DEPTT. EDY/TECH	SCALE N.T.S.	WEIGHT (KGS)	
TITLE	DRAWN NAME V.K.SHARMA (SIGN) DATE 4.9.09		
CHISEL ANGLE SCALING CHISEL FOR PNEUMATIC CHIPPER TOOL STEEL - HARDENED TEMPERED	WORKED	A.K.C.	
	CHECKED	-D.C.	23.9.09
	APPROVED	N.KHAN	
	DRAWING NO.	FT-11-90	
	SHEET NO. - 1	NO. OF SHEETS 1	

SIZE-A4

निर्माणाकर्ता WORKED BY	L Agrawal	27/09/12
जांचकर्ता CHECKED BY	T Dave	28/09/12

8

दिनांक एवं हस्ताक्षर (सं.)  
- के लिए



क्रय विनिर्देश (सी.एफ.एफ.पी.-हरिद्वार)

FF 06051 Rev 00

**PURCHASE SPECIFICATION**  
(CFPP - HARDWAR)

पृष्ठ का  
Page 4 of 5

सुपरसेड्स  
INVENTORY NO.

**COPYRIGHT AND CONFIDENTIAL**  
The information on this document is the property of Bharat Heavy Electrical Limited. It must not be used directly or indirectly in any way detrimental to the interest of the company.

स्वत्वाधिकार एवं गोपनीयता  
हस्तक्षेप में दी गई सूचना भारत हेवी इलेक्ट्रिकल्स की सम्पत्ति है। इसका प्रयोग केवल के लिए ही नहीं किया जा सकता, जो कि कंपनी के हित में हानिकारक हो न किता जाए।

हस्ताक्षर एवं दिनांक  
SIGN & DATE

सामग्री चुनी संख्या

ALL DIMENSIONS ARE IN INCHES

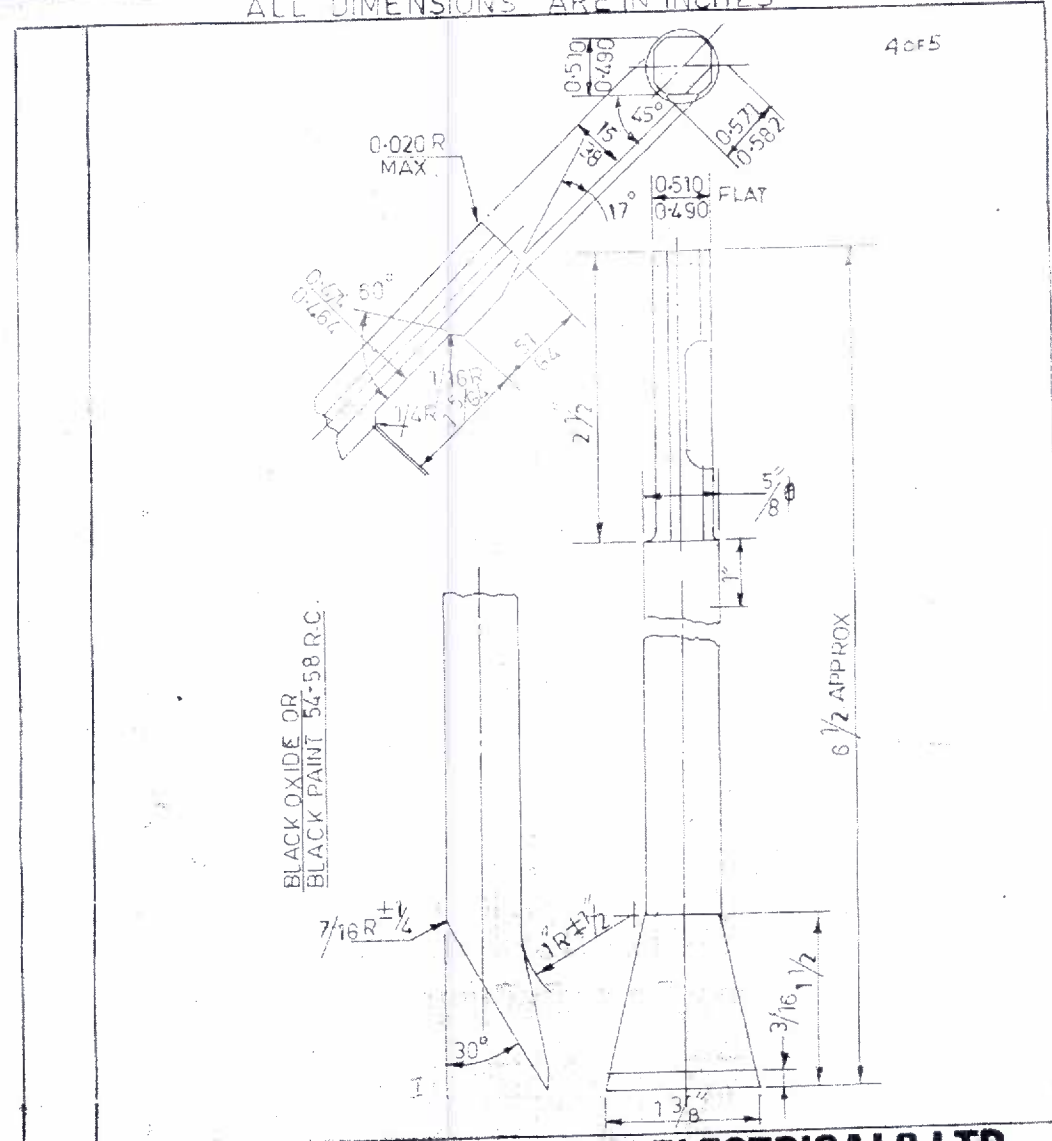

BLACK OXIDE OR  
BLACK PAINT 54-58 R.C.

**BHARAT HEAVY ELECTRICALS LTD.**  
UNIT: CENTRAL FOUNDRY FORGE PLANT.  
HARDWAR.

DEPTT	FDY/TECH	SCALE	N.T.S.	WEIGHT (KGS.)	
TITLE	CHISEL ANGLE SCALING CHISEL FOR PNEUMATIC CHIPPER TOOL STEEL - HARDENED TEMPERED				
DRAWN	V.K. SHARMA	SIGN		DATE	4-9-90
WORKED	A.K.C.				
CHECKED	-D.C.-				
APPROVED	N.KHAN				
DRAWING NO.	FT-11-90				
SHEET NO.	1	NO. OF SHEETS	1		

SIZE-A4

निर्माणकर्ता WORKED BY	L Agrawal	जांचकर्ता CHECKED BY	T Dave
	<i>(Signature)</i>		<i>(Signature)</i>
			27/07/12
			27/07/12