



MAHARATNA
COMPANY

MATERIAL MANAGEMENT (PURCHASE)
CENTRAL FOUNDRY FORGE PLANT, BHEL HARDWAR
RANIPUR, HARIDWAR (INDIA) – 249403

Phone No. 01334-281277/284684, FAX No. 01334-225892

e-mail : ranjank@bhelhwr.co.in, kraj@bhelhwr.co.in, rranjeet@bhelhwr.co.in

Sub: Open Tender Enquiry No: 4412P/360/3/0581F1

Dear Sir,

We are pleased to invite offer as per enclosed specification with terms and conditions in sealed envelop for the under mentioned material.

SI No	Tender No	Description of Material	Quantity	Date & Time of Tender Opening
01	4412P/360/3/0581F1	Different Types of Castings.	1001 Nos	23.04.14 at 2.00 PM (IST)

Kindly read terms and conditions carefully. Offer not submitted in accordance with the instructions is liable to be disqualified or ignored.

Please visit www.bhel.com or www.bhelhwr.co.in for more details and tender documents.

Please also download Supplier Registration Form and submit same dully filled.

Thanking You,

Yours Faithfully,
For & On behalf of CFFP BHEL Hardwar

(Raj Kishore)
Manager (Purchase)

Note: All corrigenda, addenda, amendments, time extensions, clarifications, etc. to the tender if any shall not be published, kindly visit web-site for any changes.



निविदा सूचना
TENDER ENQUIRY

भारत हैवी इलैक्ट्रिकल्स लिमिटेड
Bharat Heavy Electricals Ltd
सेन्ट्रल फाउन्ड्री फॉर्ज प्लांट- हरिद्वार - २४६४०३ (भारत)
Central Foundry Forge Plant, Haridwar-249403 (INDIA)

Phone : (0091) 01334- 281639,281385,285336 Fax : 01334 225892 / 226458

TIN NO. 05001763485
C S T NO. HR-5018287 Dt. 16-03-1995

निविदा सूचना सं. ENQUIRY NO.*	4412 P/ 360/3/0581F1	दिनांक Date	19-03-2014
-------------------------------	-----------------------------	-------------	-------------------

कृपया निम्नलिखित के लिए निविदा दें। PLEASE QUOTE FOR THE FOLLOWING :

M/S. :: **DUEDATE 23-04-2014**
 ::
 :
Vendor Code 09285
INDIA

SL	MATERIAL CODE ITEM DESCRIPTION	QUANTITY	UNIT	LOTNO	LOT DELIVERY QTY SCHEDULE
1	FF8121060168 DRG: 03-07-006 (LARGE) REV: DOOR BOTTOM LIP CASTING LARGE MATL-HRCI AS PER DRAWING.	20	NO	1	20 30/07/14
2	FF8121060176 DRG: 03-07-006 (SMALL) REV: DOOR BOTTOM LIP CASTING SMALL MATL-HRCI AS PER DRG.	6	NO	1	6 30/07/14
3	FF8121060125 DRG: 03-07-004 (LARGE) REV: DOOR SIDE CASTING LARGE MATL-HRCI AS PER DRG.NO	30	NO	1	30 30/07/14
4	FF8121060133 DRG: 03-07-004 (SMALL) REV: DOOR SIDE CASTING SMALL MATL-HRCI AS PER DRG	6	NO	1	6 30/07/14
5	FF8121060311 DRG: 01-08-027, ITEM NO-2 REV: SIDE FIXED HEARTH CASTING	52	NO	1	52 30/07/14
6	FF8121060494 DRG: D01.08.028 SHEET-2, ITEM NO-3C REV: BOGIE CASTING FOR VULCAN FURNA CE AS PER GRAWING	40	NO	1	40 30/07/14
7	FF8121060508 DRG: 05.00.032SH-1, ITEM NO-3 REV: BOGIE CASTING FOR VULCAN FURNA CE AS PER DRAWING.	5	NO	1	5 30/07/14
8	FF8121060516 DRG: 05.00.032SH-1, ITEM NO-7 REV: BOGIE CASTING FOR VULCAN FURNA	5	NO	1	5 30/07/14

* महत्वपूर्ण : कृपया कोटेशन देने से पूर्व पीछे दिए गये अनुदेशों को ध्यानपूर्वक पढ़िये।
IMPORTANT : PLEASE READ CAREFULLY THE INSTRUCTIONS GIVEN ON REVERSE BEFORE QUOTING



निविदा सूचना
TENDER ENQUIRY

भारत हैवी इलैक्ट्रिकल्स लिमिटेड
Bharat Heavy Electricals Ltd
सेन्ट्रल फाउन्ड्री फोर्ज प्लांट- हरिद्वार - २४६४०३ (भारत)
Central Foundry Forge Plant, Haridwar-249403 (INDIA)

AA-17001

Phone : (0091) 01334- 281639,281385,285336 Fax : 01334 225892 / 226458

TIN NO. 05001763485
C S T NO. HR-5018287 Dt. 16-03-1995

निविदा सूचना सं. ENQUIRY NO.*	4412 P/ 360/3/0581F1	दिनांक Date	19-03-2014
-------------------------------	----------------------	-------------	------------

कृपया निम्नलिखित के लिए निविदा दें। PLEASE QUOTE FOR THE FOLLOWING :

MATERIAL CODE	QUANTITY	UNIT	LOTNO	ITEM DESCRIPTION
CE AS PER DRAWING				
9 FF8121060397	95	NO	1	95 30/07/14
DRG: 01-08-028SHEET-2, ITEM NO-2C REV: BOGIE CASTING				
10 FF8121060524	5	NO	1	5 30/07/14
DRG: 05.00.032, SH-2, ITEM NO-4 REV: BOGIE CASTING FOR VULCAN FURNA CE AS PER DRAWING				
11 FF8121060532	5	NO	1	5 30/07/14
DRG: 05.00.032, SH-2, ITEM NO-8 REV: BOGIE CASTING FOR VULCAN FURNA CE AS PER DRAWING				
12 FF8121060370	5	NO	1	5 30/07/14
DRG: 01-08-027, ITEM NO-8 REV: END CORNER FIXED HEARTH CASTING AS PER DRAWING.				
13 FF8121060346	5	NO	1	5 30/07/14
DRG: 01-08-027, ITEM NO-5 REV: END SIDE FIXED HEARTH CASTING AS PER DRAWING				
14 FF8121060354	8	NO	1	8 30/07/14
DRG: 01-08-027, ITEM NO-6 REV: END CORNER FIXED HEARTH CASTING AS PER DRAWING				
15 FF8121060320	5	NO	1	5 30/07/14
DRG: 01-08-027, ITEM NO-3 REV: SIDE CORNER FIXED HEARTH CASTING AS PER DRAWING.				
16 FF8121060338	5	NO	1	5 30/07/14
DRG: 01-08-027, ITEM NO-4 REV: SIDE CORNER FIXED HEARTH CASTING AS PER DRAWING				
17 FF8121060303	5	NO	1	5 30/07/14
DRG: 01-08-027, ITEM NO-1 REV: SIDE FIXED HEARTH CASTING				

Page No 2

★ महत्वपूर्ण : कृपया कोटेशन देने से पूर्व पीछे दिए गये अनुदेशों को ध्यानपूर्वक पढ़िये।

IMPORTANT : PLEASE READ CAREFULLY THE INSTRUCTIONS GIVEN ON REVERSE BEFORE QUOTING



निविदा सूचना
TENDER ENQUIRY

भारत हेवी इलेक्ट्रिकल्स लिमिटेड
Bharat Heavy Electricals Ltd
सेन्ट्रल फाउन्ड्री फॉर्ज प्लांट- हरिद्वार - २४६४०३ (भारत)
Central Foundry Forge Plant, Haridwar-249403 (INDIA)

Phone : (0091) 01334- 281639,281385,285336 Fax : 01334 225892 / 226458

TIN NO. 05001763485
C S T NO. HR-5018287 Dt. 16-03-1995

निविदा सूचना सं. ENQUIRY NO.*	4412 P/ 360/3/0581F1	दिनांक Date	19-03-2014
-------------------------------	----------------------	-------------	------------

कृपया निम्नलिखित के लिए निविदा दें। PLEASE QUOTE FOR THE FOLLOWING :

MATERIAL CODE	QUANTITY	UNIT	LOTNO	ITEM DESCRIPTION
18 FF8121060427	35	NO	1	35 30/07/14 DRG: 01-08-028SHEET-3, ITEM NO-5 REV: BOGIE CASTING AS PER DRAWING
19 FF8121060540	12	NO	1	12 30/07/14 DRG: 01.08.028SHEET-3, ITEM NO-1 REV: BOGIE CASTING FOR VULCAN FURNA CE AS PER DRAWING
20 FF8121060559	35	NO	1	35 30/07/14 DRG: 01.08.028SHEET-3, ITEM NO-2 REV: BOGIE CASTING FOR VULCAN FURNA CE AS PER DRG.
21 FF8121060362	5	NO	1	5 30/07/14 DRG: 01-08-027, ITEM NO-7 REV: END CORNER FIXED HEARTH CASTING G AS PER DRAWING
22 FF8121011515	15	NO	1	15 30/07/14 DRG: DRG.NO-01.01.005R2 REV: SIDE TOP & BOTTOM CASTING DRG.NO.01-01-005 R2 MATERIAL-H.R.STEEL
23 FF8121060141	25	NO	1	25 30/07/14 DRG: 03-07-005 (LARGE) REV: FRONT WALL CASTING LARGE AS PER DRAWING
24 FF8121011370	8	NO	1	8 30/07/14 DRG: DRG.NO.01,01,156 R3. REV: FRONT DOOR SEAL CASTING DRG.NO.01 01 156 R3 ITEM -1 MATL.HEAT RESISTANT STEEL
25 FF8121060206	4	NO	1	4 30/07/14 DRG: 03-07-008 ITEM NO-1 REV: DOOR LIP CORNER CASTING MATL-HRCI AS PER DRG,
26 FF8121060214	4	NO	1	4 30/07/14 DRG: 03-07-008 ITEM NO-2 REV:

Page No 3

★ महत्वपूर्ण : कृपया कोटेशन देने से पूर्व पीछे दिए गये अनुदेशों को ध्यानपूर्वक पढ़िये।

IMPORTANT : PLEASE READ CAREFULLY THE INSTRUCTIONS GIVEN ON REVERSE BEFORE QUOTING



AA-17001

निविदा सूचना
TENDER ENQUIRY

भारत हेवी इलैक्ट्रिकल्स लिमिटेड
Bharat Heavy Electricals Ltd
सेन्ट्रल फाउन्ड्री फोर्ज प्लांट- हरिद्वार - २४६४०३ (भारत)
Central Foundry Forge Plant, Haridwar-249403 (INDIA)

Phone : (0091) 01334- 281639,281385,285336 Fax : 01334 225892 / 226458

TIN NO. 05001763485
C S T NO. HR-5018287 Dt. 16-03-1995

निविदा सूचना सं. ENQUIRY NO.*	4412 P/ 360/3/0581F1	दिनांक Date	19-03-2014
-------------------------------	----------------------	-------------	------------

कृपया निम्नलिखित के लिए निविदा दें। PLEASE QUOTE FOR THE FOLLOWING :

MATERIAL CODE QUANTITY UNIT LOTNO
ITEM DESCRIPTION

DOOR LIP CORNER CASTING
MATL-HRCI AS PER DRG

27 FF8121060184 8 NO 1 8 30/07/14
DRG: 03-07-007 ITEM-1 REV:
DOOR CORNER (TOP) CASTING
MAYTL-HRCI AS PER DRAWING

28 FF8121060192 8 NO 1 8 30/07/14
DRG: 03-07-007 ITEM-2 REV:
DOOR CORNER (TOP) CASTING
MATL-HRCI AS PER DRG

29 FF8151930020 6 NO 1 6 30/07/14
DRG: 05-111-002,R0 REV:
BOGIE CASTINGS
AS PER DRAWING

30 FF8151920173 12 NO 1 12 30/07/14
DRG: 05-13-002 R0. REV:
CORNER CASTING AS PER DRG.

31 FF8151920181 30 NO 1 30 30/07/14
DRG: 05-13-001 R0. REV:
T CASTING AS PER DRG.

32 FF8151920165 40 NO 1 40 30/07/14
DRG: 05-13-004 R0. REV:
SQUARE CASTING AS PER DRG.

33 FF8151920157 30 NO 1 30 30/07/14
DRG: 05-13-003 R0 REV:
DOOR L CASTING AS PER DRG.

34 FF8121011094 10 NO 1 10 30/07/14
DRG: DRG.NO-01.01.017R2,TYPE-1 REV:
SIDE SEAL CASTING FOR FIXED HE
ARTH,MATL.-H.R.STEEL

35 FF8121020212 2 NO 1 2 30/07/14
DRG: 01-08-005 R1 REV:
BOGIE HOLDING CORNER CASTING
FOR VULCAN FURNACE.

Page No 4

★ महत्वपूर्ण : कृपया कोटेशन देने से पूर्व पीछे दिए गये अनुदेशों को ध्यानपूर्वक पढ़िये।

IMPORTANT : PLEASE READ CAREFULLY THE INSTRUCTIONS GIVEN ON REVERSE BEFORE QUOTING



निविदा सूचना
TENDER ENQUIRY

भारत हैवी इलैक्ट्रिकल्स लिमिटेड
Bharat Heavy Electricals Ltd
सेन्ट्रल फाउन्ड्री फोर्ज प्लांट- हरिद्वार - २४६४०३ (भारत)
Central Foundry Forge Plant, Haridwar-249403 (INDIA)

AA-17001

Phone : (0091) 01334- 281639,281385,285336 Fax : 01334 225892 / 226458

TIN NO. 05001763485
C S T NO. HR-5018287 Dt. 16-03-1995

निविदा सूचना सं. ENQUIRY NO.*	4412 P/ 360/3/0581F1	दिनांक Date	19-03-2014
-------------------------------	----------------------	-------------	------------

कृपया निम्नलिखित के लिए निविदा दें। PLEASE QUOTE FOR THE FOLLOWING :

MATERIAL CODE ITEM DESCRIPTION	QUANTITY	UNIT	LOTNO	
36 FF8121020220 DRG: 01-08-023 R1 REV: DOOR CASTING TOP BD-7 FOR VULCAN FURNACE.	10	NO	1	10 30/07/14
37 FF8121020239 DRG: -01-08-024 R1 REV: DOOR CASTING BOTTOM BD-8 FOR VULCAN FURNACE	10	NO	1	10 30/07/14
38 FF8121020247 DRG: 01-08-008 R1 REV: DOOR SIDE CASTING FOR VULCAN FURNACE.	30	NO	1	30 30/07/14
39 FF8121020255 DRG: 03-30-002 REV: BOGIE CASTING.	50	NO	1	50 30/07/14
40 FF8121020263 DRG: 03-30-009 REV: SIDE COLUMN CASTING	50	NO	1	50 30/07/14
41 FF8121020271 DRG: 03-30-010 REV: SIDE COLUMN CASTING.	50	NO	1	50 30/07/14
42 FF8121020280 DRG: 03-30-011 REV: TOP COLUMN CASTING.	30	NO	1	30 30/07/14
43 FF8121020000 DRG: 03-27-001 REV: BOGIE CORNER CURB CASTING	4	NO	1	4 30/07/14
44 FF8121020123 BOGIE SIDE CURB CASTING SIZE: 03-27-002 DIM.: D	30	NO	1	30 30/07/14
45 FF8121020131 BOGIE SIDE SAND TROUGH CASTING (380). SIZE: 03-27-003	30	NO	1	30 30/07/14

Page No 5

* महत्वपूर्ण : कृपया कोटेशन देने से पूर्व पीछे दिए गये अनुदेशों को ध्यानपूर्वक पढ़िये।

IMPORTANT : PLEASE READ CAREFULLY THE INSTRUCTIONS GIVEN ON REVERSE BEFORE QUOTING



निविदा सूचना
TENDER ENQUIRY

AA-17001

भारत हैवी इलैक्ट्रिकल्स लिमिटेड
Bharat Heavy Electricals Ltd
सेन्ट्रल फाउन्ड्री फोर्ज प्लांट- हरिद्वार - २४६४०३ (भारत)
Central Foundry Forge Plant, Haridwar-249403 (INDIA)

Phone : (0091) 01334- 281639,281385,285336

Fax : 01334 225892 / 226458

TIN NO. 05001763485
C S T NO. HR-5018287 Dt. 16-03-1995

निविदा सूचना सं. ENQUIRY NO.*

4412 P/ 360/3/0581F1

दिनांक Date

19-03-2014

कृपया निम्नलिखित के लिए निविदा दें। PLEASE QUOTE FOR THE FOLLOWING :

MATERIAL CODE QUANTITY UNIT LOTNO
ITEM DESCRIPTION

DIM.: D

46 FF8121020034 2 NO 1 2 30/07/14
DRG: 03-27-004 REV:
BOGIE SIDE SAND TROUGH CASTING

47 FF8121020042 2 NO 1 2 30/07/14
DRG: 03-27-005 REV:
BOGIE SIDE SAND TROUGH CASTING
(MIRROR IMAGE)

48 FF8121020050 10 NO 1 10 30/07/14
DRG: 03-27-006 REV:
BOGIE BACK SAND TROUGH CASTING
392

49 FF8121020069 30 NO 1 30 30/07/14
DRG: 03-27-007 REV:
FIXED HEARTH UPPER SAND SEAL
CASTING

50 FF8121020077 30 NO 1 30 30/07/14
DRG: 03-27-008 REV:
FIXED HEARTH LOWER SAND SEAL
CASTING

51 FF8121020085 10 NO 1 10 30/07/14
DRG: 03-27-009 REV:
FDOOR BOTTOM SAND SEAL CASTING

52 FF8121020093 11 NO 1 11 30/07/14
DRG: 03-27-010 REV:
DOOR TOP SAND SEAL CASTING

53 FF8121020107 11 NO 1 11 30/07/14
DRG: 03-27-011 REV:
DOOR TOP SAND TROUGH CASTING

54 FF8121020115 10 NO 1 10 30/07/14
DRG: 03-27-012 REV:
DOOR FRONT ANGLE CASTING

** IMPORTANT: This enquiry is 2 part tender. Techno-Commercial bid (Part-1) & Price Bids (Part-2) should be submitted in separate envelopes. These two envelopes should

Page No 6

★ महत्वपूर्ण : कृपया कोटेशन देने से पूर्व पीछे दिए गये अनुदेशों को ध्यानपूर्वक पढ़िये।

IMPORTANT : PLEASE READ CAREFULLY THE INSTRUCTIONS GIVEN ON REVERSE BEFORE QUOTING

निविदा सूचना सं. ENQUIRY NO.*	4412 P/ 360/3/0581F1	दिनांक Date	19-03-2014
-------------------------------	----------------------	-------------	------------

कृपया निम्नलिखित के लिए निविदा दें। PLEASE QUOTE FOR THE FOLLOWING :

MATERIAL CODE	QUANTITY	UNIT	LOTNO
ITEM DESCRIPTION			

be submitted in a common sealed envelope. Techno-Commercial Bid shall contain detailed Technical Specification, Drawings Technical documents, Catalogues, taxes & duties, payment terms, delivery period, Validity of offer, Replica of Price Bid (Copy of price bid without price part) etc. The confirmation to the special terms & conditions must be submitted alongwith Techno-Commercial bid.

Standard Instructions:

GUARANTEE CERTIFICATE REQUIRED.
BASIC RATES, TAXES DUTIES SEPERATELY
CENVATABL DUPLICATE COPY OF INVOICE.
INSP AFTER RECPT AT CFFP.

* Delivery schedule mentioned in T.E is tentative, actual delivery schedule will be as per point no 5 of annexure-1 of Commercial terms.

Special Instructions:

GUARANTEE CERTIFICATE IS REQUIRED FOR THE PERIOD OF ONE YEAR.
EARLY DELIVERY IS ALSO ACCEPTABLE.
PLEASE PROVIDE ONE INTEGRAL TEST PIECE/SAMPLE FOR EACH HEAT AT THE TIME OF DELIVERY.

General Instructions:

1. Please submit authorization letter (format enclosed) for facilitating e-payment/electronic transfer of funds
 2. 100% payment within 30 days after receipt & acceptance of material at CFFP BHEL, Hardwar through e-payment.
 3. CFFP/BHEL RESERVES THE RIGHT TO PRE-INSPECT THE MATERIAL AT VENDOR'S WORKS / GODOWN/ PREMISES BEFORE DESPATCH.
 4. ORIGINAL MANUFACTURER'S TEST CERTIFICATE IS REQUIRED ALONG WITH DESPATCH DOCUMENTS. IN CASE SUPPLIES ARE FROM TRADERS, IT SHALL BE THE RESPONSIBILITY OF THE TRADER TO PROVIDE ORIGINAL MANUFACTURER'S TEST CERTIFICATE WITH LINKAGE TO TRADER'S INVOICE STATING BATCH NO.
 5. CFFP/BHEL Reserves the right to procure from more than one vendor.
 6. Please quote prices in figures & words both. In case the prices quoted in words and figures are different, the values indicated in words will be considered for evaluation & establishing L1 status.
- * The offers of the bidders who are on the banned list as also the offers of the bidders, who engage the services of the banned firms, shall be rejected. The list of banned firms is available on web site www.bhel.com

MANOJ KUMAR YADAVA
SR. ENGINEER (PUR.)

GENERAL TERMS AND CONDITIONS OF TENDER ENQUIRY
ANNEXURE-B

01 Submit the tender in two parts i.e.

Part-I Techno-Commercial Bid

Part-II Price Bid

Techo - Commercial (part one) Price Bid (part two) should be put in separate sealed envelopes. Both envelopes should be super scribed with **Tender Number, Date of opening & Technical / Commercial Bid and Price Bid** respectively along with name of firm.

Both the envelopes i.e. containing Techno-Commercial Bid and Price Bid should again be kept in one envelope super scribed again with Tender No. and Date of opening and the name of firm submitting the tender and send it to **AGM (MM), Purchase Department, CFFP/BHEL, Hardwar, Ranipur, Hardwar 249403, Uttarakhand, India before due date / tender opening date & time**. Normally tender opening time is 2.00 PM on due date or as mentioned in enquiry.

Responsibility for submission of tender in time solely lies with vendor. Late offers received after specified time / Date shall not be considered.

1. Part-I Envelopes super scribed with **Techno-Commercial Bid** must contain all information especially-
 - (a) Specification of the material offered should be strictly as per CFFP/BHEL specifications of enquired material in tender documents **Deviations if any must be indicated clearly in the offer. Rates to be quoted on For Destination Basis.**
 - (b) All commercial terms i.e. packing, forwarding Custom duty, Additional Duty, ST/STT/VAT/CST, Excise Duty/CVD. Bank charges, payment terms & insurance etc as applicable (**except price**) should be clearly mentioned in Techno-Commercial bid. Also mention present rate of applicable taxes & duties even if inclusive in rates along with the concessional forms required if any.
 - (c) Confirm to submit all required commercial documents (tax invoice centvatable duplicate copy of invoice, packing list, transit sale agreement etc.) & technical documents (TC/GC/QP etc).
 - (d) Registration Numbers of SSI, Central Excise, Sales tax, Income Tax, DGS & D.ECC etc.
 - (e) **Un-priced copy of Price Bid.**

Part-II Envelopes super scribed with Price Bid should contain priced copy of Price Bid. The price should be mentioned both in figures and words.

2. Authorized Signatory should authenticate all tender documents.
3. **Techno-commercial bid (Part-I)** will be opened on the due date at 2.00 PM in the presence of participating vendors or authorized representatives, who may wish to be present. Representative deputed to witness tender opening must produce an authority letter from the signatory of offer. After evaluation of technical bids & finalization of technical, commercial terms & conditions, price bid of only successful vendors will be opened. Priced bid opening date shall be intimated separately.
4. The material offered must conform to the required BHEL specifications and drawings as well as instructions and details made available.
5. For new vendors, Vendor Registration from duly filled must be submitted along with the offer which can be downloaded from our web site www.bhel.com or www.bhelhwr.co.in.
6. Original manufacturer's Test Certificate is required along with dispatch documents. In case supplies are from traders, it shall be the responsibility of the trader to provide original manufacture's test certificate with linkage to traders invoice stating batch no.
7. **Validity** of offers should be minimum 90 working days from the date of tender (Techno-Commercial Bid) opening.

8. **Delivery** in the promised period is the essence of contract. Confirm to supply according to delivery schedule mentioned.
9. **Payment terms:**
For indigenous suppliers: 100% within 30 days after receipt & acceptance of material at CFFP / BHEL, Haridwar through e-payment.
For foreign suppliers: Payment through USANCE LC on 70th day of bill of lading date. All bank charges shall be to vendor's account.

* In case vendor does not agree, proper loading shall be done. Also in that case, third party inspection shall have to be arranged by supplier from any of the five inspection agencies namely: LRS/ BVQI/ DNV/ TUV/ Alfred H Knight at their cost.
10. CFFP/BHEL, Hardwar reserves the right to accept or reject any or all tenders without assigning any reason thereof.
11. Tenders not submitted in the prescribed manner are likely to be ignored / rejected.
12. Agent/Agency Commissioning: Payment of any kind at any stage will not be made to agent on account of agent commission or otherwise by CFFP/BHEL, Hardwar.
13. CFFP/BHEL, Hardwar may opt for E-auction/Reverse auction for obtaining best prices for part or full tendered quantity. BHEL also reserve the right to negotiate price with L1 vendor after reverse auction.
14. Please do intimate the personal contact details like Name, Mobile Number, Email-id etc of authorized executive for correspondence.
15. **Penalty:** Orders placed against this enquiry will be subject to normal clauses for imposing penalty. Liquidated Damages, Risk purchases, cancellation, arbitration as per terms and conditions of Tender Enquiry and Purchase orders in case of delay in effecting supply and/ or other defaults.
Liquidated damage: The delivery of the goods shall be made strictly as per time limit specified in delivery schedule, failure to supply within this period will make the supplier liable to an conditional penalty of 1/2 (half) percent of the price of the goods in arrears per week subject to a maximum of 10%.
16. **Inspection:** Final inspection of material shall be done after receipt of material at CFFP/BHEL, Hardwar. Acceptance of material shall be after final inspection and shall be binding. However, CFFP reserves the right to pre Inspect the material at supplier works. In case material is found defective during warranty period, the same will be returned for repair and/ or replacement. For this vendor has to bear all the charges such as Freight, to and fro insurance etc. Bank Guarantee for the equal amount to the cost of the item is to be furnished by vendor. In case the repair is done at CFFP/BHEL the amount on actual shall have to be reimbursed by the Vendor and or adjusted on actual from their bill.
17. **Currency of Payment:** Mention the currency in which payment has to be made. For evaluation of price bids, exchange rate (TT selling rate of SBI) as on scheduled date of tender opening (Part-1 bid in case of two part bid) shall be considered.
18. Traders should submit authorization letter from their principal alongwith offer.
19. Disputes: In event of any dispute arising out of contractual obligation, the order being finalized at Hardwar, India will be subject to Indian Laws and falls under jurisdiction of the court of Law at Haridwar, India. The overseas supplier hereafter referred to as "Vendor" shall therefore abide by the verdict of Court of Law at Hardwar, India.
OR
All disputes arising out of or in connection with the present contract, if any shall be finally settled under the rules of arbitration of International chamber of commerce by one or more arbitrator appointed in accordance with the said Rules in India.
20. BHEL reserves the right to place P.O. for part / full qty and on one or more than one sources.
21. Any Term & condition of the specific tender (if specified in tender & contradicts with above term) will supersede the above general terms & conditions.

PRE QUALIFICATION CRITERIA

Ref: Open tender enquiry no. 4412P/360/3/0581F1 for different types of castings

This criteria governs the techno-commercial requirement for supply of all type of castings mentioned in the requirement. Offer of only those bidders will be considered who shall qualify following criteria (clause 1 to 5) and submit the documentary proof against each criterion wherever required.

S.No.	Requirements	Vendor's Response
1.	The annual sales of the vendor should be Rs. 1.0 Crore or above for twice in last five years. Party must submit copy of PAN card, Income Tax Return for last five years & Audited balance sheet of last five years. In case vendor is found solvent, BHEL may cancel the offer/PO at any stage without any binding on BHEL.	
2.	Vendor is required to provide the documentary evidence of successfully executed orders of castings in last five years.	
3.	The integral test piece / sample of each heat pertaining to our material may be required to provide with its laboratory test report at the time of delivery.	
4.	The vendors who are new to CFFP BHEL Haridwar (i.e.,not having vendor code in CFFP vendor list) are required to submit the filled SRF (Supplier Registration Form) along with all the documents required. The form can be downloaded through below link. http://www.bhel.com/vender_registration/pdf/Guidelines_to_Indian_Suppliers_SEARP2010Amdt_04for_web.pdf The offer is liable to be ignored/ rejected if "new" vendor fails to submit the SRF with the offer.	
5.	BHEL reserves the right to verify the information provided by the vendor. In case the information provided by the vendor is found to be false/ incorrect, the offer will be rejected.	

COMMERCIAL TERMS & CONDITIONS**Tender Enquiry No.: 4412/P/360/20130581F1**

Name of Vendor:.....

	Conditions	Vendor's Confirmation / Comments.
1	Guarantee Certificate shall be provided for the period of one year by the vendor.	
2	Test Certificate (with linkage to supplied material) shall be provided along with dispatch documents.	
3	Final inspection of material will be done after receipt of material at CFFP. All the charges (like To & Fro freight, insurance etc.) for replacement shall be borne by supplier. Date of receipt of replacement material if accepted shall be considered as actual delivery date with respect to the PO delivery date for calculating penalty for Late Delivery.	
4	<p>Delivery Term :-</p> <p>A. <u>For Indian Suppliers:</u> FOR, Destination (Door delivery basis). Destination will be CFFP, BHEL, Haridwar.</p> <p>B. <u>For Foreign suppliers:</u> On CIF, Nhava Sheva , Mumbai</p> <p>Quoted rate should be inclusive of the charges like freight, service tax on freight, insurance, packing & forwarding etc. for the delivery term given above or else proper loading shall be done.</p>	
5	<p>Delivery Schedule :-</p> <p>Vendor is requested to quote earliest possible delivery schedule.</p>	
6	<p><u>Conditions for opening of Price :-</u></p> <ol style="list-style-type: none"> BHEL reserves the right to go for Reverse Auction (RA) instead of opening the sealed envelope price bid, submitted by the bidder. This will be decided after techno-commercial evaluation. All bidders to give their acceptance for participation in RA. Non-acceptance to participate in RA may result in non-consideration of their bids, in case BHEL decides to go for RA. In case BHEL decides to go for Reverse Auction, Only those bidders who have given their acceptance to participate in RA will be allowed to participate in the Reverse Auction. Those bidders who have given their acceptance to participate in Reverse Auction will have to necessarily submit „online sealed bid“ in the Reverse Auction. Non-submission of „online sealed bid“ by the bidder will be considered as tampering of the tender process and will invite action by BHEL as per extant guidelines in vogue. In case BHEL decides to go for Reverse Auction, the H1 bidder (whose quote is highest in online sealed bid) may not be allowed to participate in further RA process. 	

7	<p>Payment Terms: For Indian suppliers - 100% within 30 days after receipt & acceptance of material at CFFP / BHEL, Haridwar through e-payment. In case vendor does not agree, proper loading shall be done</p> <p>Loading will be @ Base rate of SBI (as applicable on the dated of bid opening, Techno-commercial bid opening in case of two part bids) + 6%, shall be considered for loading for the period of relaxation sought by bidders.</p> <p>For foreign suppliers: Payment through USANCE LC on 70th day of bill of lading date. All bank charges shall be to vendor's account. In case vendor does not agree, proper loading shall be done. Loading will be @ Base rate of SBI (as applicable on the dated of bid opening, Techno-commercial bid opening in case of two part bids) + 6%, shall be considered for loading for the period of relaxation sought by bidders.</p>	
8	Validity of offers : minimum 90 days from tender opening date	
9	Evaluation of price bids will be done on the basis of total delivered cost at CFFP i.e. Landed cost net of Cenvat at CFFP.	
10	BHEL may place order for part quantity. Quoted rate not to be linked with order quantity.	
11	Rates shall be Firm till execution of purchase order.	
12	Material will be supplied as per delivery schedule required in tender enquiry / PO (FOR destination basis). Any request for extension in delivery schedule of Purchase Order / waiver of LD is liable to be ignored.	
13	<p>Normal clauses for imposing Penalty, Liquidated Damages for Late Delivery, Risk purchases, Cancellation, Arbitration in case of delay in effecting supply and or other defaults as per following conditions will be applicable:</p> <p>a. Penalty for Late Delivery: The delivery of the goods shall be made strictly as per time limit specified in delivery schedule, failure to supply within this period will make the seller liable to a penalty of 1/2 (half) percent of the price of the goods in arrears per week subject to a maximum of 10% on the basic rate (total PO value). Any correspondence regarding waiver of LD shall not be entertained. In case supplier does not agree for LD clause, BHEL will load maximum penalty under LD clause, to the extent the same is not agreed by the vendor, for the purpose of comparative statement. Where deliveries quoted are not suiting, BHEL may ignore the offer.</p> <p>b. Risk Purchase: In case of delays in supplies / defective supplies or non-fulfillment of any other terms and conditions given in the Purchase Order by the seller, the Buyer reserves the right to cancel the purchase order in full or part thereof, and may also make the purchase of such material from alternative source <u>at the risk and cost of the seller.</u></p>	

14	For new vendors who are not registered with CFFP BHEL Haridwar, duly filled up "Supplier Registration Form" (available at www.bhel.com) along-with all the supporting documents has to be submitted along-with techno-commercial bid of offer. Please confirm that SRF is being submitted with your offer if applicable. However please note that if in any case duly filled up SRF along-with all the supporting documents is not received within 15 days of tender opening, your offer may liable to be ignored.	
15	BHEL will prefer to deal directly with foreign vendor/ original manufacturer. In case, vendor engages any Indian agent or take service of any Indian agent, copy of agent agreement required along with offer in line with Annexure-IV attached.	
16	In the event of any dispute arising out of contractual obligation, the order being finalized at Haridwar, India will be subject to Indian Laws and falls under jurisdiction of the court of Law at Haridwar, India.	
17	Indian Vendors shall quote their price only in INR. Foreign vendors shall quote their price only in USD, EURO, UK POUND STERLING and JAPANESE YEN. For evaluation of price bids, exchange rate (TT selling rate of SBI) as on scheduled date of tender opening (Part-1 bid in case of two part bid) shall be considered.	
18	Vendor shall quote price both in words & figures. If there is any difference between price quoted in words & figures, price quoted in words shall prevail and binding.	
19	Please confirm to provide one integral test piece/sample for each heat at the time of delivery.	
20	Please provide contact person name, telephone nos. , fax no. & email id.	
21	A. In case of any difference in conditions quoted above & elsewhere in the offer, terms quoted above shall be treated as final and binding on vendor. B. Evaluation shall be on the basis of delivered cost (i.e.) "total cost to BHEL". C. Non acceptance of any of the above conditions may result in rejection of your offer. D. Terms & Conditions not specified above will be as per Annexure-B No GTCRM NO. 01 Rev.05 Date: 25.10.12 enclosed. E. In case of blank / no comments in provided remark column, it shall be deemed to have been accepted by vendor.	

Date:

Signature with Name of authorized signatory)

Seal of the Company

Terms and conditions regarding Indian agent of foreign suppliers:

01. BHEL shall deal directly with foreign vendors, wherever required, for procurement of goods. However, if the foreign principal desires to avail of the services of an Indian agent, then the foreign principal should ensure compliance to regulatory guidelines- which require mandatory submission of an Agency agreement.
02. It shall be incumbent on the Indian agent and the foreign principal to adhere to the relevant guidelines of Government of India, issued from time to time.
03. The agency agreement should specify the precise relationship between the foreign OEM/Foreign principal and their Indian agent and their mutual interest in the business. All services to be rendered by agent/associate, whether of general nature or in relation to the particular contract, must be clearly stated by the foreign supplier / Indian agent. Any payment, which the agent or associate receives in India or aboard from the OEM, whether as commission or as a general retainer fee should be brought on record in the agreement and be made explicit in order to ensure compliance to laws of the country.
04. Any agency commission to be paid by BHEL to the Indian agent shall be in Indian currency only.
05. Tax deduction at source is applicable to the agency commission paid to the Indian agent as per the prevailing rules.
06. In the absence of any agency agreement, BHEL shall not deal with any Indian agent (authorized representatives/ associate/consultant, or by whatever name called) and shall deal directly with the foreign principal only for all correspondence and business purposes.
07. The "Guidelines for Indian Agents of Foreign Suppliers" enclosed at annexure- 'A' shall apply in all such cases.
08. The supply and execution of the Purchase Order (including indigenous suppliers/service) shall be in the scope of the OEM/ Foreign principal. The OEM/ Foreign principal should submit their offer inclusive of all indigenous suppliers/services and evaluation will be based on 'total cost to BHEL'. In case OEM/ foreign principal recommends placement of order(s) towards indigenous portion of supplies/services on Indian Supplier (s)/ agent on their behalf, the credentials/capacity/capability of the Indian Supplier (s)/ agent to make the supplies/Services shall be checked by BHEL as per the extant guidelines of Supplier Evaluation, Approval and Review Procedure (SEARP), before opening of price bids. In this regards, details may be checked as per Annexure- 'B' (copy enclosed). It will be the responsibility of the OEM/ Foreign Principal to get acquainted with the evaluation requirements of Indian supplier/agent as per SEARP available on www.bhel.com.

The responsibility for successful execution of the contract (including indigenous supplies/services) lies with the OEM/ foreign principal. All bank guarantees to this effect shall be in the scope of the OEM/Foreign principal.

Guidelines for Indian Agents of Foreign Suppliers

- 1.0 There shall be compulsory registration of agents for all Global (Open) Tender and Limited Tender. An agent who is not registered with BHEL shall apply for registration in the registration form in line with SEARP.
 - 1.1 Registered agents will file an authenticated Photostat copy duly attested by a Notary Public/Original certificate of the Principal confirming the agency agreement and giving the status being enjoyed by the agent and the commission/ remuneration/ salary/ retainership being paid by the principal to the agent before the placement of order by BHEL.
 - 1.2 Wherever the Indian representatives have communicated on behalf of their principals and the foreign parties have stated that they are not paying any commission to the Indian agents, and the Indian representative is working on the basis of salary or as retainer, a written declaration to this effect should be submitted by the party (i.e. Principal) before finalizing the order.
- 2.0 Disclosure of particulars of agents/ representatives in India, if any.**
- 2.1 Tenderers of Foreign nationality shall furnish the following details in their offers:
 - 2.1.1 The Bidder(s)/ Contractor(s) of foreign origin shall disclose the name and address of the agents/ representatives in India if any and the extent of authorization and authority given to commit the Principals. In case the agent/ representative be a foreign Company, it shall be confirmed whether it is existing Company and details of the same shall be furnished.
 - 2.1.2 The amount of commission/ remuneration included in the quoted price(s) for such agents/ representatives in India.
 - 2.1.3 Confirmation of the Tenderer that the commission/ remuneration, if any, payable to his agents/ representatives in India, may be paid by BHEL in Indian Rupees only.
 - 2.2 Tenderers of Indian Nationality shall furnish the following details in their offers:
 - 2.2.1 The Bidder(s)/ Contractor(s) of Indian Nationality shall furnish the name and address of the foreign principals, if any, indicating their nationality as well as their status, i.e. whether manufacturer or agents of manufacturer holding the Letter of Authority of the Principal specifically authorizing the agent to make an offer in India in response to tender either directly or through the agents/ representatives.
 - 2.2.2 The amount of commission/ remuneration included in the price (s) quoted by the Tenderer for himself.
 - 2.2.3 Confirmation of the foreign principals of the Tenderer that the commission/ remuneration, if any, reserved for the Tenderer in the quoted price(s), may be paid by BHEL in India in equivalent Indian Rupees on satisfactory completion of the Project or supplies of Stores and Spares in case of operation items.
 - 2.3 In either case, in the event of contract materializing, the terms of payment will provide for payment of the commission/ remuneration, if any payable to the agents/ representatives in India in Indian Rupees on expiry of 90 days after the discharge of the obligations under the contract.
 - 2.4 Failure to furnish correct and detailed information as called for in paragraph 2.0 above will render the concerned tender liable to rejection or in the event of a contract materializing, the same liable to termination by BHEL. Besides this there would be a penalty of banning business dealings with BHEL or damage or payment of a named sum.

---X---

This format is applicable only to Indian Suppliers/ Agents supplying indigenous portion of Foreign Purchases.

* In all other cases, extant guidelines of SEARP, 2010 are to be followed.

SEARP (SRF) Clause No	Detail
	Name & address of the firm
1.0	Products/ Systems / Services being considered for
2.0	General Information
2.2	Name of Chief Executive
2.3	Details of authorized signatory
3.0	Ownership Information
3.1	Type of firm
3.2	Nature of Business <ul style="list-style-type: none"> • <i>Attach authorization letter and agency agreement from Principal (from whom capital equipment is procured)</i> • <i>Attach copy of declaration from Foreign Principal for total guarantee/ warranty of indigenous supplies</i>
3.3	Year of establishment
3.4	Year of commencement of business
4.0	Registration particulars
4.1	Permanent Account No.
4.2 / 4.3	Sales Tax / TIN no
4.6	Service tax no. (in case of E&C)
5.0	Organisational strength
6.0	Other particulars
6.1	If the company is already registered with other units
6.2	Directors/ Partners, if related to any BHEL Employee
6.9	If any Ex BHEL Personnel employed by the Company
6.12	Details of pending legal issues with BHEL
6.13	Bank Account information
9.0	Financial information
9.6	Sales/ Turnover details of last 3 years (or from the date of incorporation whichever is less)

---X---

AUTHORISATION LETTER
FOR E-PAYMENT/ELECTRONIC FUNDS TRANSFER (EFT/RTGS)
PLEASE FILL UP THE FORM IN CAPITAL LETTERS ONLY

ANNEXURE-D
Page 1 of 1

TYPE OF REQUEST (Tick One)	<input type="checkbox"/>	CREATE	<input type="checkbox"/>	CHANGE
<u>BHEL Vendor/ Supplier Code</u>	<input type="text"/>			
Company's Name	<input type="text"/>			
Address	<input type="text"/>			
City	<input type="text"/>			
Pincode	<input type="text"/>			
State	<input type="text"/>			
Contact Person(S)	<input type="text"/>			
Telephone NO.	<input type="text"/>			
FAX. No.	<input type="text"/>			
e-mail id	<input type="text"/>			
1. Bank Name	<input type="text"/>			
2. Bank Address	<input type="text"/>			
3. Bank Telephone No.	<input type="text"/>			
4. Bank Account No.	<input type="text"/>			
5. Account Type.	<input type="text"/>			
6. Bank's Branch Code	<input type="text"/>			
7. Bank Swift Code	<input type="text"/>			
(aplicable to EFT only)				
8. Enclose blank cancelled cheque	<input type="checkbox"/>	<input type="checkbox"/>		

DECLARATION

1. I as representative/Owner of the above named company, hereby authorize BHEL CFFP, Ranipur, Haridwar to electronically make payments to the designated bank account. I hereby certify that the particulars given above are true, complete and correct.
(2) If the transsation is delayed or not effected at all for reasons of incomplete or incorrect information, I would not hold BHEL/transfereing Bank responsible.
3. This authority remains in full force untill BHEL, CFFP, Ranipur, Haridwar receives & acknowledge written notification requesting a change or cancellation.
4. I have read the contents of the covering letter and agree to discharge the responsibilty expected of me as a participant under E-payment/EFT/RTGS.

Date:

Authorized Signatory
Designation

Company Seal

Verification By Bank

REV. DRAWING NUMBER

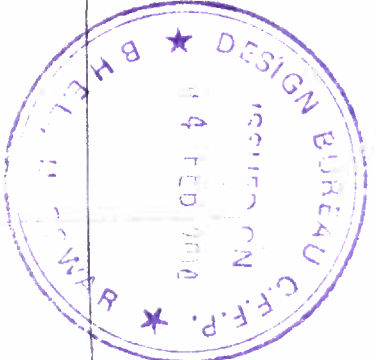
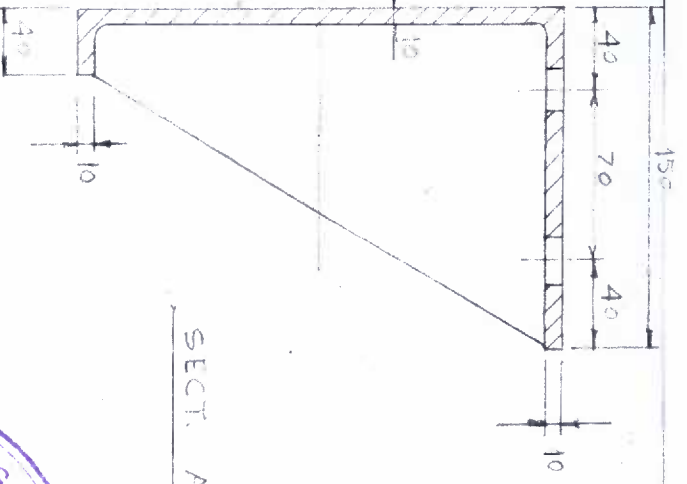
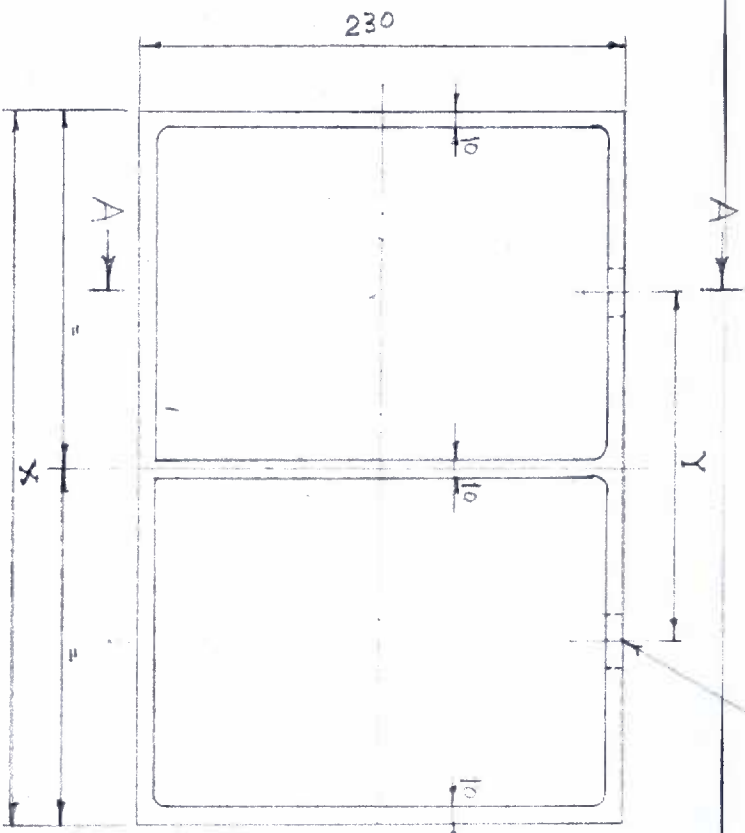

DESCRIPTION	X	Y	WT	INVENTORY NO.
LARGER CASTINGS	390	200	17 KGS	FF8121060125
SMALLER CAST.	290	100	14 KGS	FF8121060133
MIDDLE CASTINGS	330	200		

Inventory No. Sign. & Date Ref. Drg. No. 03/074/0730P1

The information on this document is the property of BHARAT HEAVY ELECTRICALS LIMITED. It must not be used directly or indirectly in anyway detrimental to the interest of the company.

MTL. HR. C.I. C 3.10% to 3.50%
 Si 2% to 2.8%
 Ni 0.8% to 1.2%
 Cu - 1.5% to 2%

REV	DATE	ALTERED	CHECKED

TYPE OF PRODUCT OR NAME OF CUSTOMER / PROJECT
BHARAT HEAVY ELECTRICALS LTD.
 UNIT: C.F.F.P., HARDWAR.

DEPT. CODE SCALE WEIGHT (KG) REF. TO ASSY. DRG. ITEM NO.

FOR VULCAN HEAT TREATMENT FURACE

Dimensions to be Controlled Within Limits as Shown
 Machining Tolerance + .25 mm Unless Otherwise Shown, Non Machining Tolerance ±

CARD CODE	DRAWING NO.	DATE	NO. OF SHEETS
03,07,004	1518 REV. 1		01

FE 8121060141 LARGER
 FE 8121060150 SMALLER
 Inventory No.

Ref. Drg. No.

The information on this document is the property of BHARAT HEAVY ELECTRICALS LIMITED.
 It must not be used directly or indirectly in anyway detrimental to the interest of the company.

Dimensions to be Controlled Within Limits as Shown
 Machining Tolerance ± 0.25 mm Unless Otherwise Shown. Non Machining Tolerance \pm

DEPT. CODE REF. TO ASSY. DRG. WEIGHT (KG) SCALE 1:5

DRAWING NO. 03,07,005 REV. 0

SHEET NO. 01 NO. OF SHEETS. 01

BHARAT HEAVY ELECTRICALS LTD.
 C.F.F.P., RANIPUR - HARDWAR.

DG-39

FRONT WALL CASTING
 VULCAN FURNACE
 STEEL FOUNDRY

DRAWN M.K.G. DATE 24.8.14
 CHECKED K.K.K. DATE 27.8.14
 APPROVED

MTL: HR. C.I. C-3.1% & 3.5%
 SL-2% & 2.8%
 NI-0.8% & 1.2%
 CR-1.5% & 2%

DESCRIPTION	X	23 Kgs	LARGER	390
DESCRIPTION	X	18 Kgs	SMALLER	320

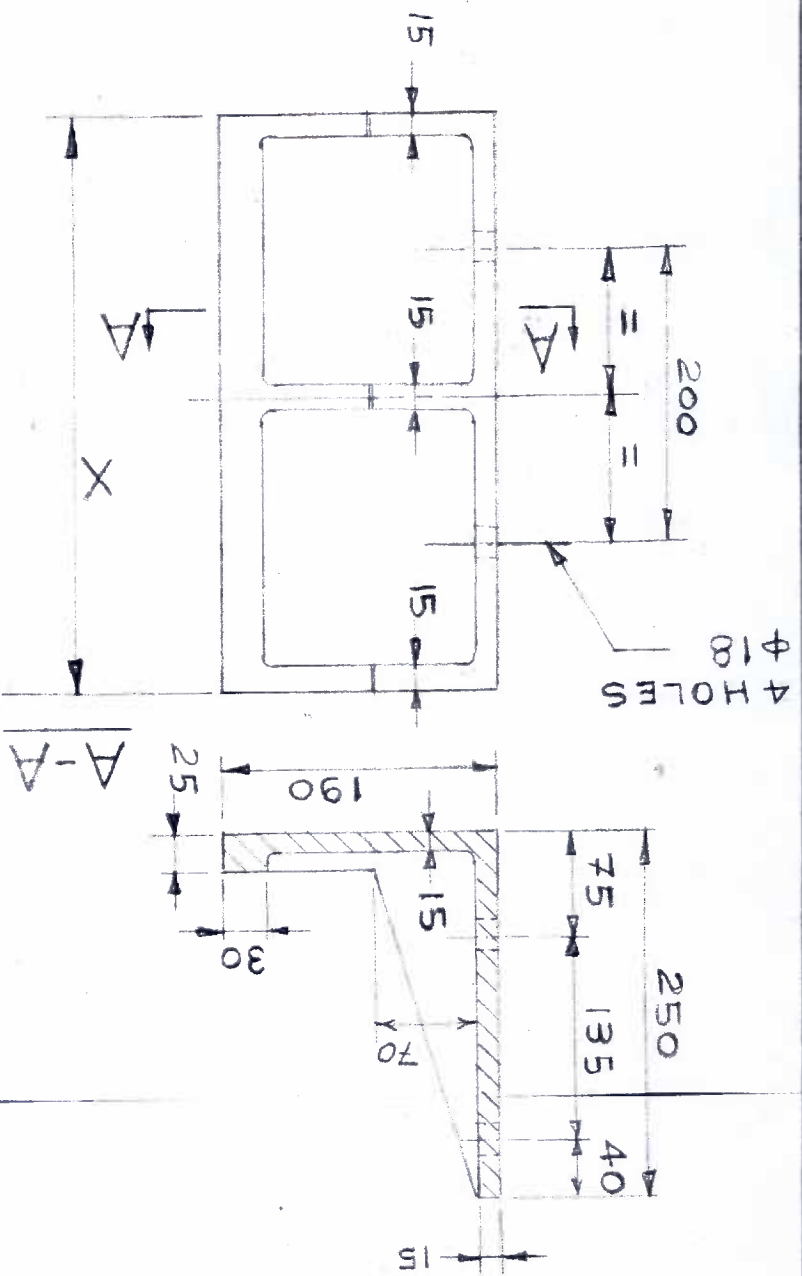

REV DATE ALTERED
 REV DATE ALTERED
 CHECKED
 CHECKED

FIRST ANGLE PROJECTION (ALL DIMENSIONS ARE IN MM)

FIRST ANGLE PROJECTION (ALL DIMENSIONS ARE IN MM)

DRAWING NUMBER

REV.

4 HOLES ϕ 18

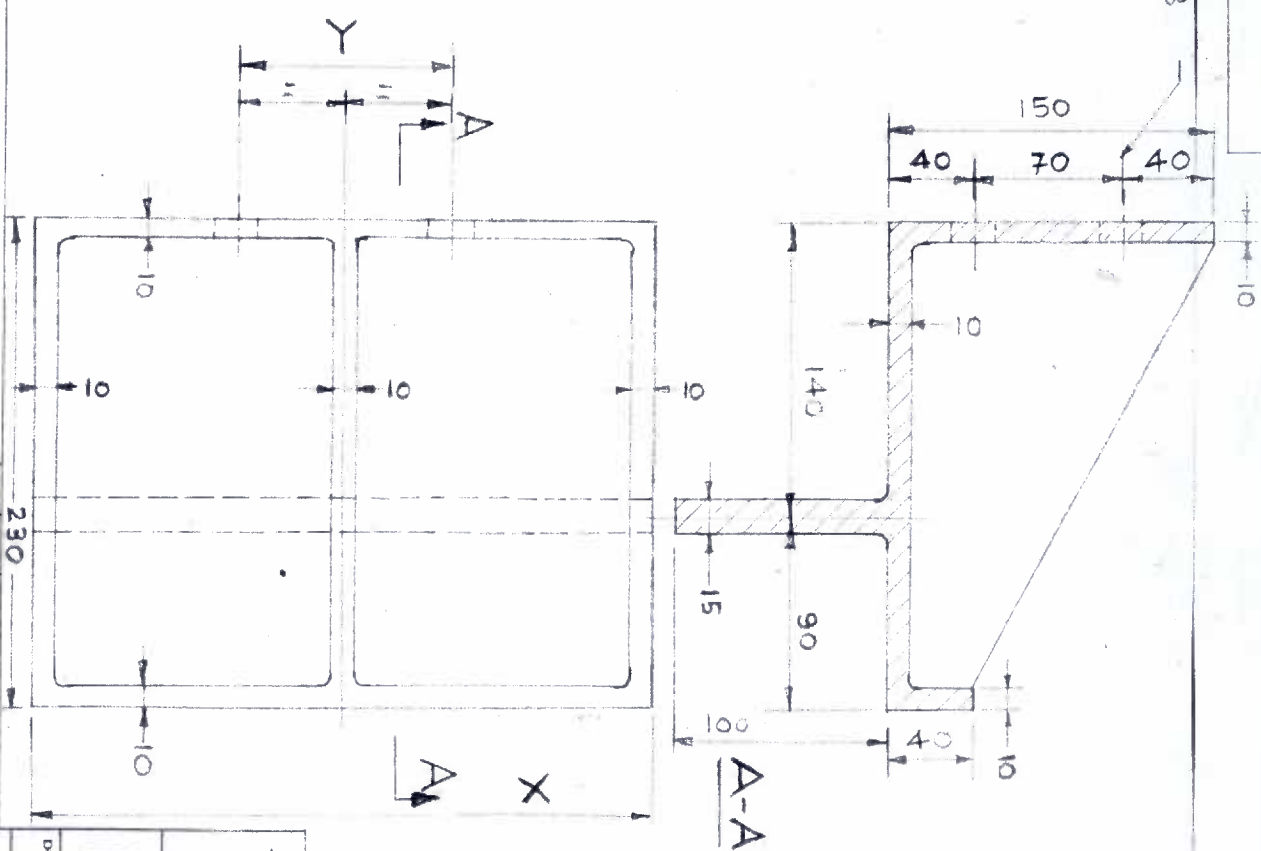

TABLE

DESCRIPTION	X	Y	W.T. IN KGS
LARGER CASTING	390	200	21.25
SMALLER CASTING	290	100	17.15

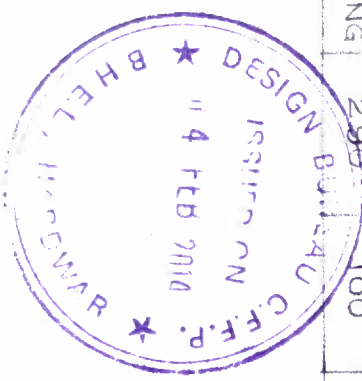

MATERIAL: H.R. C.I. C-3.1% S 3.8%
 Si-2% Mn 2.1% P
 N-0.08% S 1.2%
 CY-1.5% Cu 2.2%

The information on this document is the property of BHARAT HEAVY ELECTRICALS LIMITED. It must not be used directly or indirectly in anyway detrimental to the interest of the company.

Ref. Org. No.

LARGER
SMALLER
Sign. & Date

FF8121060168
FF8121060176
Inventory No.

TYPE OF PRODUCT
OR
NAME OF CUSTOMER / PROJECT

BHARAT HEAVY ELECTRICALS LTD.
UNIT: C.F.F.P., HARDWAR.

DEPT.	CODE	SCALE	WEIGHT (KG)	REF. TO ASSY. DRG.	ITEM NO.
		N.T.S.	17.15		

DOOR BOTTOM LIP CASTING
VULCAN HEAT TREATMENT
FURNACES

Dimensions to be Controlled Within Limits as Shown
Machining Tolerance + .25 mm Unless Otherwise Shown, Non Machining Tolerance ±

CARD CODE	DRAWING NO.	1.5/16 REV. IT
03,07,006	03,07,006	0

SHEET NO. 01 NO. OF SHEETS. 01

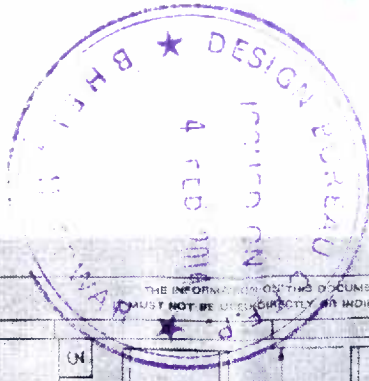

MASTER COPY

THE INFORMATION ON THIS DOCUMENT IS THE PROPERTY OF BHARAT HEAVY ELECTRICALS LIMITED
MUST NOT BE USED DIRECTLY OR INDIRECTLY IN ANY WAY DETRIMENTAL TO THE INTEREST OF THE COMPANY

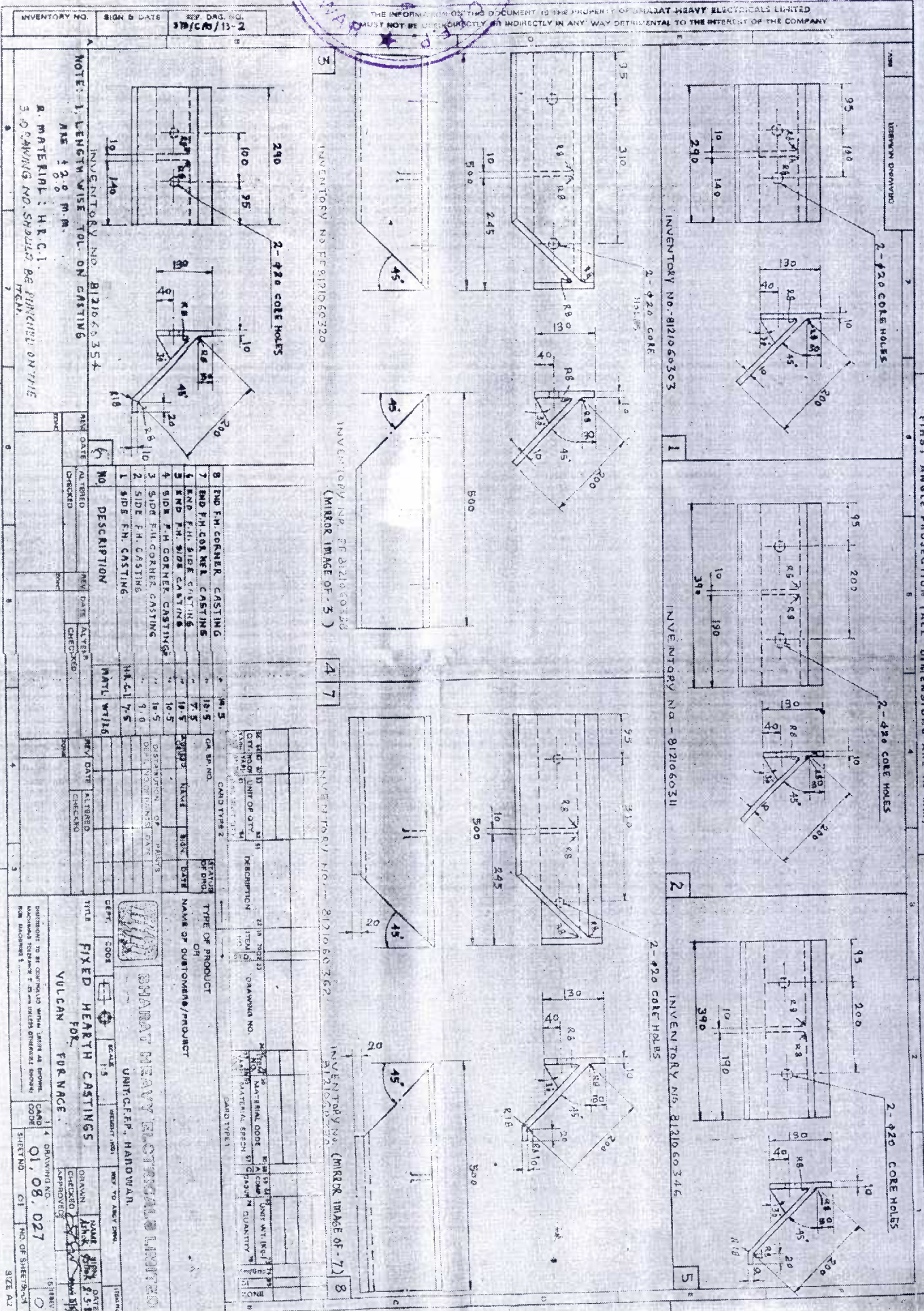

FIRST ANGLE PROJECTION (ALL DIMENSIONS ARE IN MM)

REV. DRAWING NUMBER

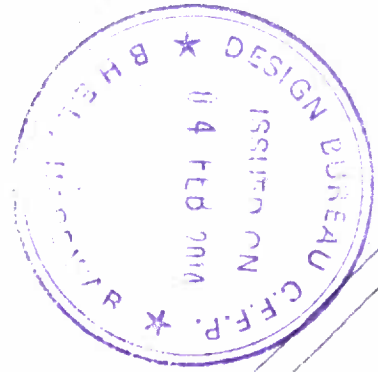
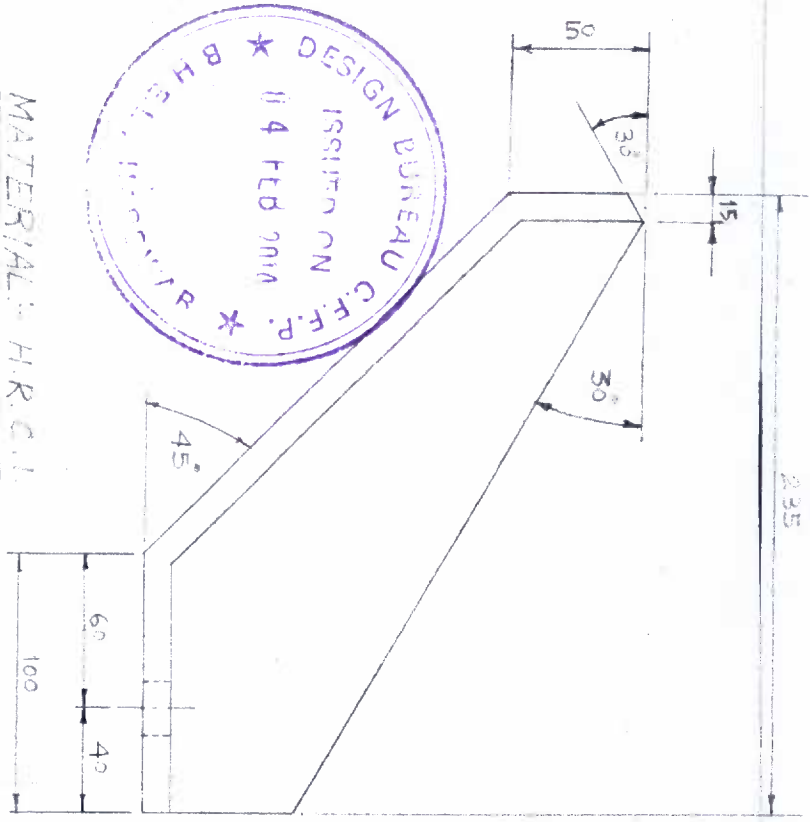
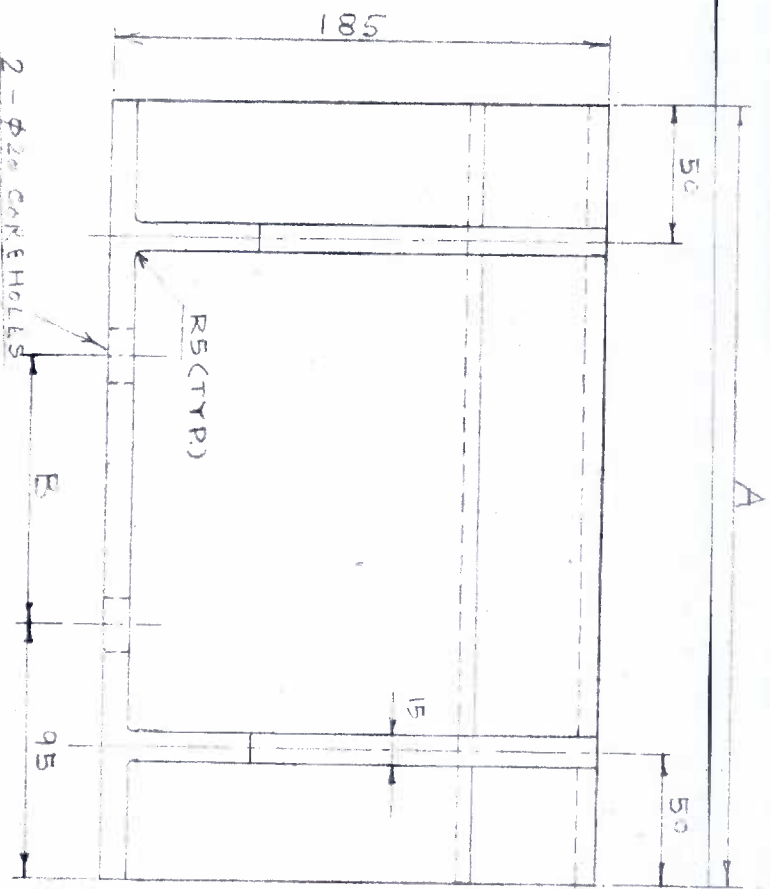

MATERIAL: H.R.C.I.
 C - 3.1% TO 3.5%
 S - 2.0% TO 2.8%
 Mn - 0.8% TO 1.2%
 Cr - 1.5% TO 2.0%

NO	INVENTORY NO.	A	B	QTY	WGT./KG.
2C	CASTING FF8121060397	340	200		16.80
2C	CASTING FF8121060494	290	100		13.30

Q. 05-046 - Pt 1A2
 (20/30)

The information on this document is the property of BHARAT HEAVY ELECTRICALS LIMITED. It must not be used directly or indirectly in anyway detrimental to the interest of the company.

Inventory No. Sign. & Date Ref. Drg. No.

STD/CRS/12-2

REV	DATE	ALTERED	REV	DATE	ALTERED
R1	10/11/81	THICKNESS CHANGED TO 10 MM TO 15 MM	R1	10/11/81	MTL CHANGED

TYPE OF PRODUCT OR NAME OF CUSTOMER / PROJECT
BHARAT HEAVY ELECTRICALS LTD.
 UNIT: C.F.F.P., HARDWAR.

DEPT. F.E. CODE SCALE WEIGHT (KG) REF TO ASSY. DRG. 77/3/11082/402-2

Bogie Casting (2C & 3C) FOR VULCAN FURNACE.

Dimensions to be Controlled Within Limits as Shown
 Machining Tolerance + 25 mm Unless Otherwise Shown, Non Machining Tolerance ±

CARD CODE SHEET NO. 01-08-028 NO. OF SHEETS 03

FIRST ANGLE PROJECTION (ALL DIMENSIONS ARE IN mm)

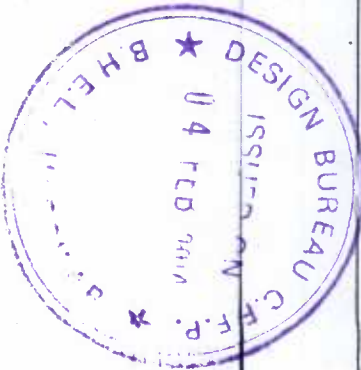
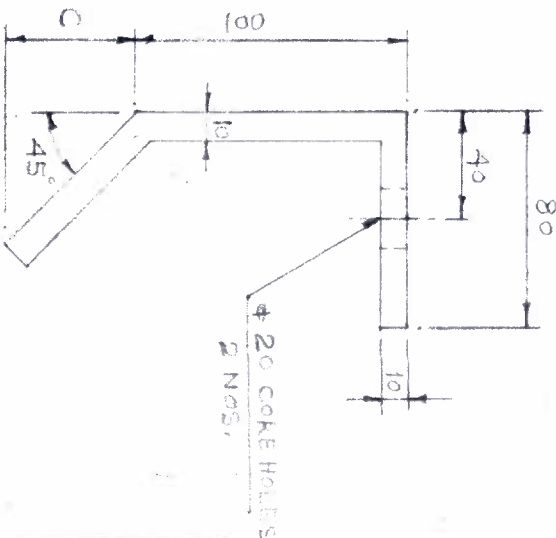
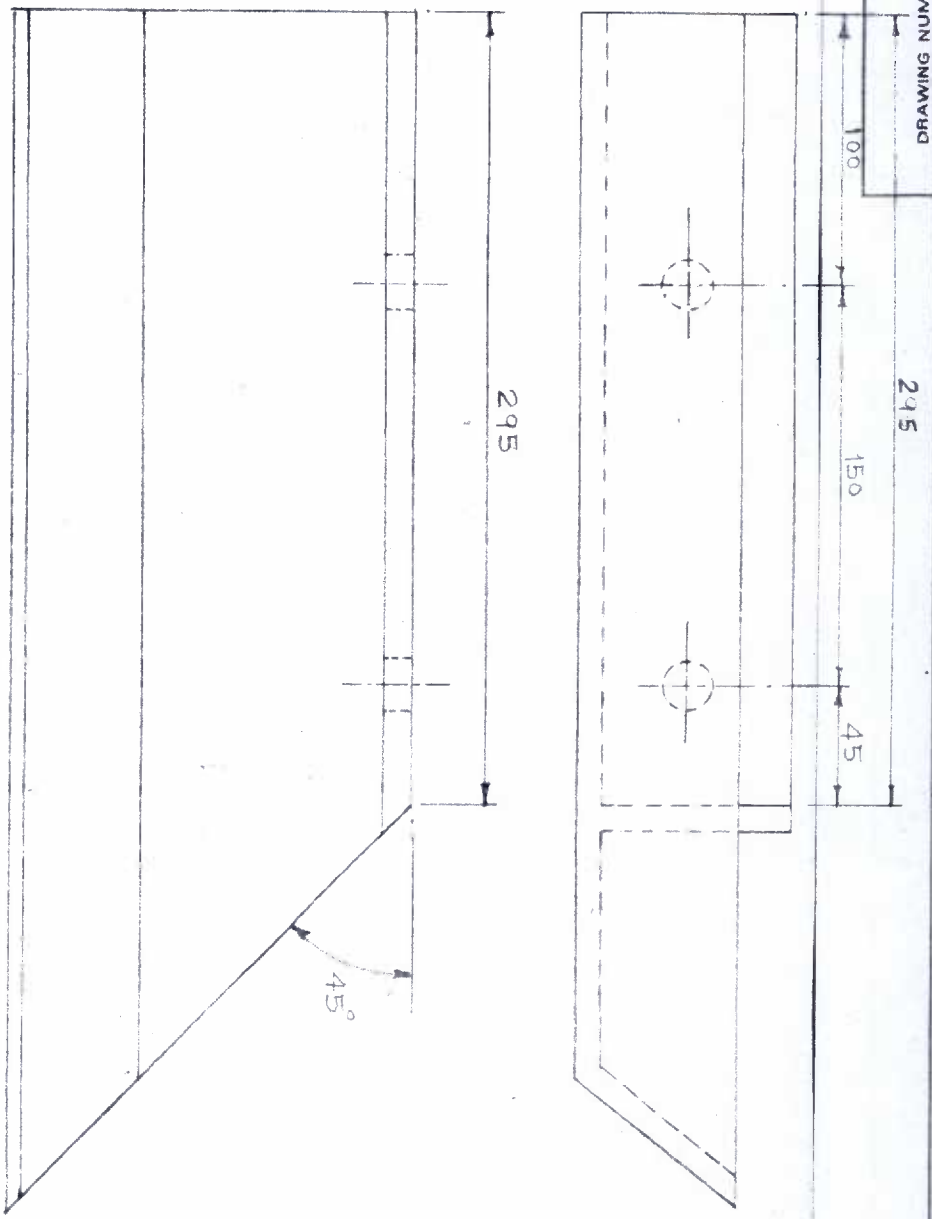

The information on this document is the property of BHARAT HEAVY ELECTRICALS LIMITED. It must not be used directly or indirectly in anyway detrimental to the interest of the company.

Ref. Drg. No. 3, 2

Sign. & Date

Inventory No.

NO.	DESCRIPTION	INVENTORY NO.	C	QTY.	WT./KG.
3	CASTING	FF8121060508	49.50		5.83
7	CASTING	FF8121060516	28.25		4.95

MATERIAL: H.F.C.I.

C - 3.1% to 3.5%
Si - 0.15% to 0.2%
Mn - 0.15% to 0.2%
P - 0.015% to 0.02%

REV	DATE	ALTERED
R1	4/8/81	CHECKED

MTL. CHANGID,

TYPE OF PRODUCT
OR
NAME OF CUSTOMER / PROJECT

BHARAT HEAVY ELECTRICALS LTD.
UNIT: C.F.P., HARDWAR.

DEPT.	CODE	SCALE	WEIGHT (KG)	REF. TO ASSY. DNG.	ITEM NO.
		1:2			

BOSIE CASTING (3&7)
FOR LFDY FURNACE

Dimensions to be Controlled Within Limits as Shown
Machining Tolerance + .25 mm Unless Otherwise
Shown, Non Machining Tolerance ±

CARD CODE	DRAWING NO.	NO. OF SHEETS
	05/00/032	1

FIRST ANGLE PROJECTION (ALL DIMENSIONS ARE IN mm)

DRAWING NUMBER

REV.

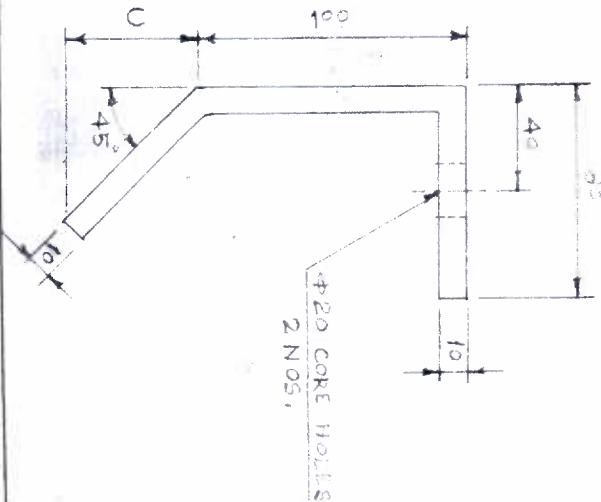
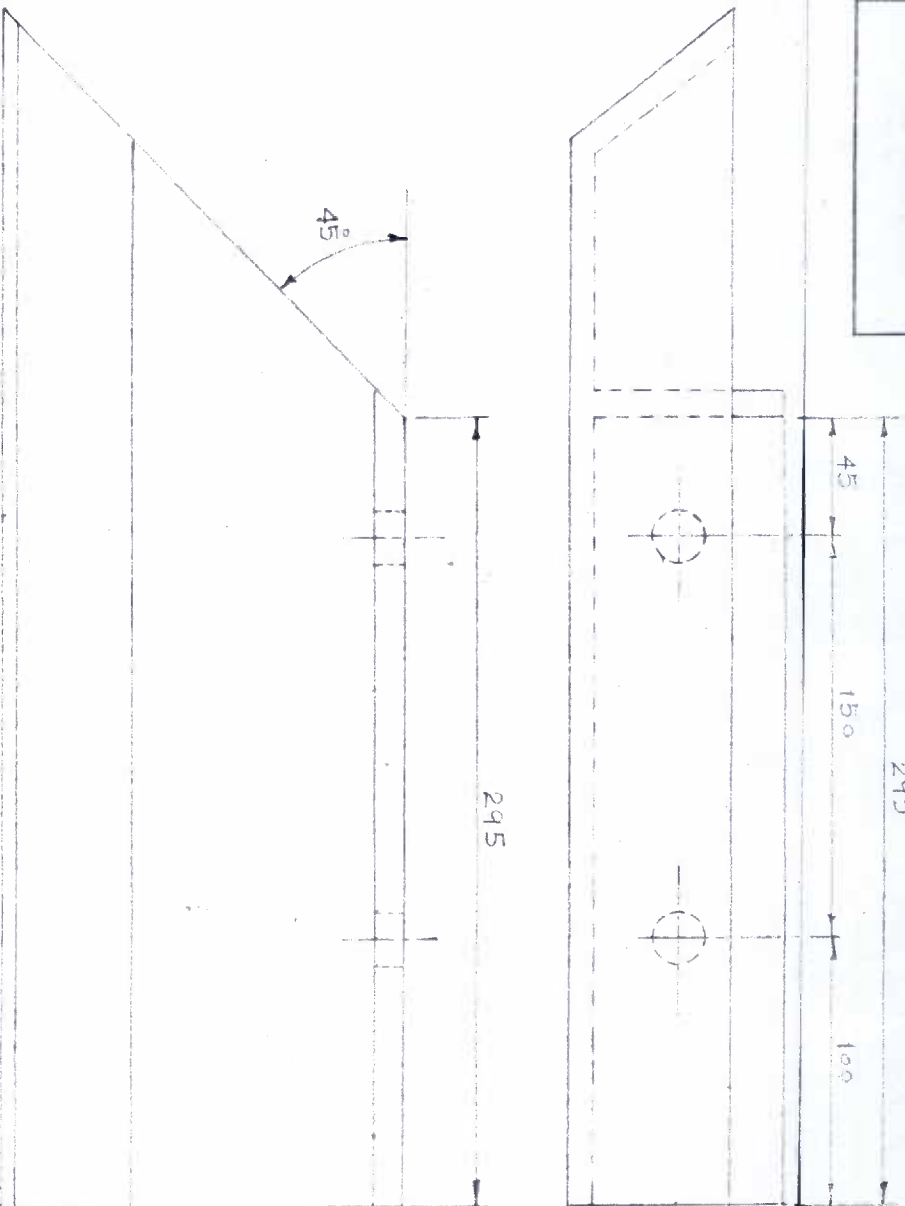

STD/GRS/12-2

The information on this document is the property of BHARAT HEAVY ELECTRICALS LIMITED. It must not be used directly or indirectly in anyway detrimental to the interest of the company.

NO	DESCRIPTION	INVENTORY NO.	C	QTY.	WT / KG.
4	CASTING	FF8121060514	49.50		5.83
8	CASTING	FF8121060532	28.25		4.95

Inventory No.	Sign. & Date	Ref. Org. No.
		4, 8

MATERIAL : H.R. C.I

C-317 To 315 /

15/2/2010

15/2/2010

15/2/2010

15/2/2010

TYPE OF PRODUCT
OR
NAME OF CUSTOMER / PROJECT

BHARAT HEAVY ELECTRICALS LTD.
UNIT: C.F.F.P., HARDWAR.

DEPT. F.E.	CODE	SCALE 1:2	WEIGHT (KG)	REF. TO ASSY. DRG.	ITEM NO.

ROGIE CASTING(4&8)
FOR LFYD FURNACE

Dimensions to be Controlled Within Limits as Shown
Machining Tolerance + .25 mm Unless Otherwise
Shown, Non Machining Tolerance ±

CARD CODE

DRAWING NO. 05,00,032

CHECKED

DRAWN

SHEET NO. 02

NO. OF SHEETS 02

15/8/10

0

CFR 8121011140
 Inventory No. 6692101115
 Sign. & Date

312077 WESMAN
 Ref. Drg. No.

The information on this document is the property of BHARAT HEAVY ELECTRICALS LIMITED.
 It must not be used directly or indirectly in anyway detrimental to the interest of the company.

Dimensions to be Controlled Within Limits as Shown
 Machining Tolerance + .25 mm Unless Otherwise
 Shown. Non Machining Tolerance ±

DEPT. CODE: 31.00
 SCALE: N.T.S.
 WEIGHT (KG): 31.00
 REF. TO ASSY. DRG.

BHARAT HEAVY ELECTRICALS LTD.
 UNIT: C.F.F.P., HARDWAR.

SIDE, TOP & BOTTOM CASTING
 P.N.O. 2.4.7
 10M FURNACE

DRAWING NO. 01.01.005
 SHEET NO. 1
 NO. OF SHEETS. 2

DATE: 3-3-81
 NAME: Ashok
 SIGN: Ashok
 CHECKED: Ashok
 APPROVED: Ashok

ACI	GRADE	DESIGN UNS. NO. ASTM SPEC.	HC	HEAT RESISTANT C.I.
R2	C	0.18	0.18	3.1
	S	0.104	0.104	2.0
	P	0.04	0.04	2.8
	S	2.0	2.0	-
	Mn	1.0	1.0	-
	Ni	0.10	0.10	0.8
	Cy	0.5	0.5	1.5
	Mo	0.5	0.5	2.0
	N	2	2	-
	M	2	2	-
	REMI	0.15	0.15	-

HEAT RESISTANT STEEL :-

SURFACED TO BE SMOOTH FINISHED BY SHOT BLASTING OR GRINDING.
 6 NOS. φ18 DRILLED HOLES FOR M16 BOLTS

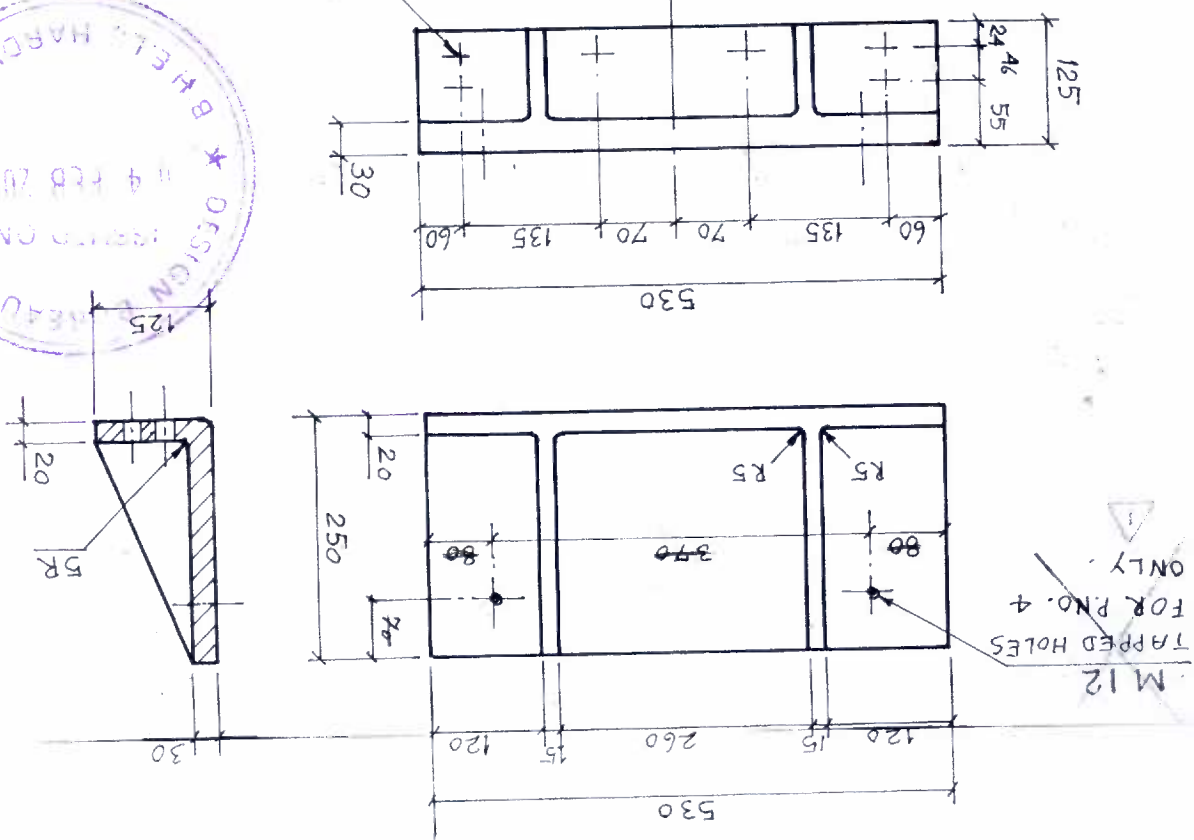

~~M12 TAPPED HOLES FOR P.N.O. 4 ONLY.~~

REV	DATE	ALTERED	REQUIRE
928	CHECKED	REQUIRE	TAP HOLES NOT
R2	5-8-81	CHECKED	change of the wall.

DOOR CASTING

FIRST ANGLE PROJECTION (ALL DIMENSIONS ARE IN mm)

FF B121020115

Inventory No.

Sign. & Date

Ref. Drg. No.



The information on this document is the property of BHARAT HEAVY ELECTRICALS LIMITED. It must not be used directly or indirectly in anyway detrimental to the interest of the company.

BHARAT HEAVY ELECTRICALS LTD. 

UNIT: C.F.F.P., HARDWAR.

DEPT. CODE:  SCALE: 1:5 WEIGHT (KG): 7.0 REF. TO ASSY. DRG. WESMAN FA-8856-1

DRAWN: Ashok Kumar SIGN: DATE: 16

CHECKED:  APPROVED: 

DRAWING NO: 03,27,012

SHEET NO. 04 NO. OF SHEETS, 01

Dimensions to be Controlled Within Limits as Shown
Machining Tolerance + 25 mm Unless Otherwise Shown. Non Machining Tolerance ±

S No.	QTY	USED IN	MT. FURNACE (S.FDY.)	WEIGHT (KG)	SCALE	DEPT. CODE
1.	16	USED IN	(8X4X2.85) M WESMAN	7.0	1:5	
		QTY INSTALLED				
		MATL. C.I. H.R.				
		C	3.1% - 3.5%			
		Sz	2.0 - 2.8			
		Nz	0.8 - 1.2			
		Cr	1.5 - 2.0			

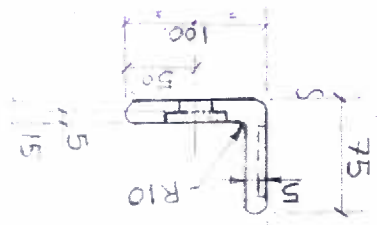
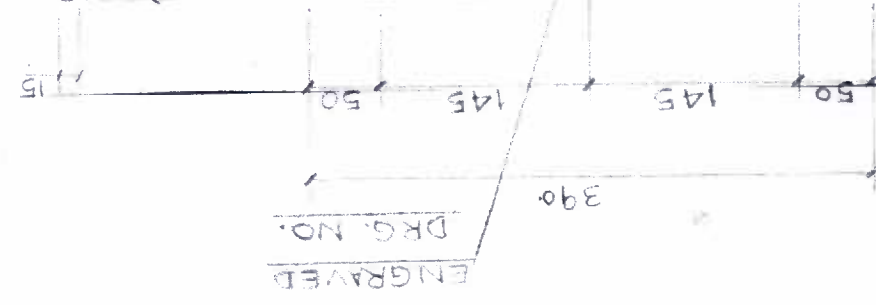
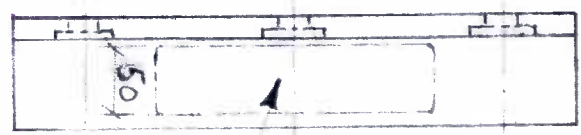
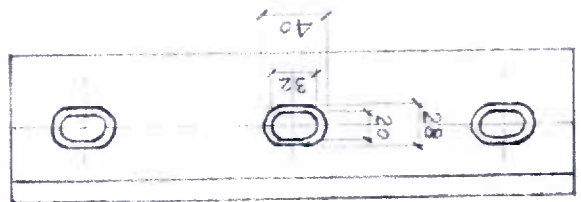

FIRST ANGLE PROJECTION (ALL DIMENSIONS ARE IN MM)

REV	DATE	ALTERED	REVISION

FF8121020107

Inventory No.

Sign. & Date

Ref. Drg. No.

The information on this document is the property of BHARAT HEAVY ELECTRICALS LIMITED. It must not be used directly or indirectly in anyway detrimental to the interest of the company.

DEPT. DESIGN CODE REF. TO ASSY. DRG. WESMAN 15
 SCALE 1:5 WEIGHT (KG) 15.0
 MACHINING TOLERANCE + .25 mm Unless Otherwise Shown. Non Machining Tolerance ±

APPROVED PARAS 18.2.96
 CHECKED
 DRAWN ASHOK KUMAR
 NAME SIGN DATE
 DRAWING NO. 03, 27, 011
 SHEET NO. 01 NO. OF SHEETS, 01

BHARAT HEAVY ELECTRICALS LTD. UNIT: C.F.F.P., HARDWAR.

S. NO.	QTY	USED IN	MATL. - C.I. H.R.
1	11	(8 X 4 X 2.85) M WESMAN (H.T. FURNACE / S.F.DX)	C 3.1% - 3.15%
			S 2.0 - 2.8
			N 0.8 - 1.2
			CR 1.5 - 2.0

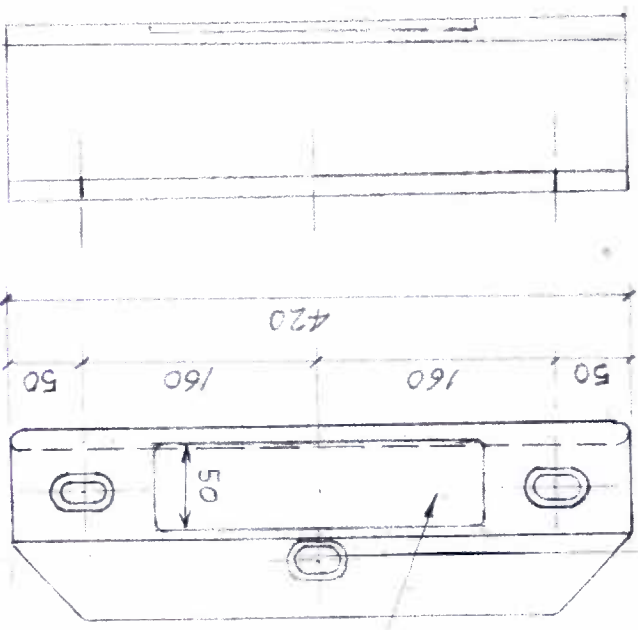

ENGRAVED DRG. NO.

REV	DATE	ALTERED	CHECKED

FF 8121020093
Inventory No.

Sign. & Date

Ref. Drg. No.

The information on this document is the property of BHARAT HEAVY ELECTRICALS LIMITED.
It must not be used directly or indirectly in anyway detrimental to the interest of the company.

Dimensions to be Controlled Within Limits as Shown
Machining Tolerance + .25 mm Unless Otherwise
Shown. Non Machining Tolerance ±

DEPT. DESIGN CODE SCALE WEIGHT (KG) REF. TO ASSY. DRG. WEIGHT ITEM NO.

DOOR TOP SAND SEAL CASTING

DRAWING NO. 03,27,010
SHEET NO. 01
NO. OF SHEETS: 01

APPROVED PARAG
CHECKED KISHORI
DRAWN ASHOK
DATE 12.2.14
SIGN. NAME DATE

BHARAT HEAVY ELECTRICALS LTD.
UNIT: C.F.P., HARDWAR.



S. No.	QTY	USED IN	NO.	DESCRIPTION
1	11	H.T. FURNACE (S.FDY.)		
		(8X 4X 2.85) M WESMAN		
		INSTALLED		

MATL:	C. I. H. R.	PERCENTAGE	QTY
C	3.1%	3.5%	
S	2.0%	2.8%	
N	0.8%	1.2%	
CR	1.5%	2.0%	



CORED HOLES
DETAIL

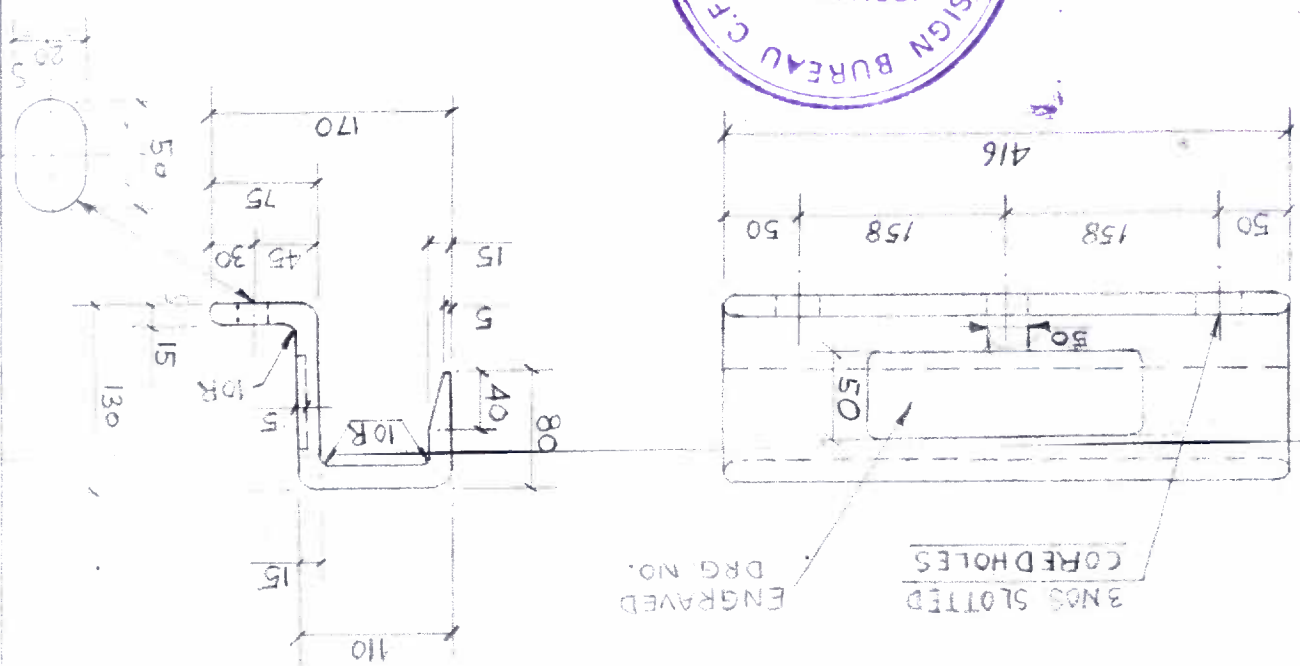

REV	DATE	ALTERED	REV	DATE	ALTERED
		CHECKED			CHECKED
		ALTERED			ALTERED

FIRST ANGLE PROJECTION (ALL DIMENSIONS ARE IN mm)

SIZE: A4

FF8121020085

Inventory No. Sign. & Date

Ref. Drg. No.

The information on this document is the property of BHARAT HEAVY ELECTRICALS LIMITED. It must not be used directly or indirectly in anyway detrimental to the interest of the company.

Dimensions to be Controlled Within Limits as Shown
Machining Tolerance + 25 mm Unless Otherwise
Shown, Non Machining Tolerance ±

CARD CODE
DRAWING NO. 03,27,009
SHEET NO. 01
NO. OF SHEETS. 01

DEPT. DESIGN CODE SCALE WEIGHT (KG) REF. TO ASSY. DRG. WESMAN
FA-8856-1
SIGN. DATE
DRAWN ASHOK KISHOR
CHECKED KISHOR
APPROVED PARAG
ITEM NO. 13

BHARAT HEAVY ELECTRICALS LTD. UNIT: C.F.P., HARDWAR.

S. NO.	QTY	USED IN	INSTALLD
1	10	(8x4x2.85) M WESMAN H.T FURNACE (S.FDY)	

MATL: C.I. H.R.	C	S	N	CR
	3.1% - 3.5%	2.0	0.8	1.5
		-2.8	-1.2	-2.0

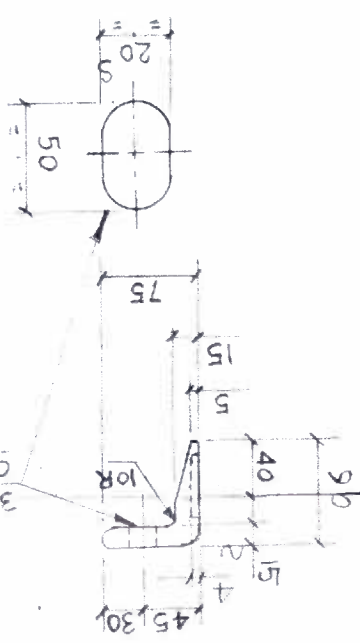
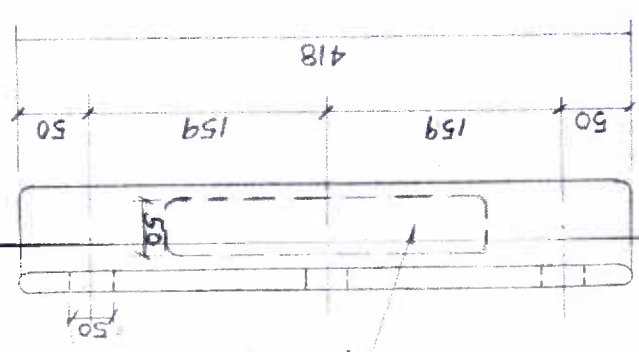

ENGRAVED DRG. NO.

3 NOS. SLOTTED
CORED HOLES.

FIRST ANGLE PROJECTION (ALL DIMENSIONS ARE IN mm)

REV	DATE	ALTERED	REV DATE	ALTERED	CHECKED

SIZE A4

FF 8121020077

Inventory No.

Sign. & Date

Ref. Drg. No.

The information on this document is the property of BHARAT HEAVY ELECTRICALS LIMITED. It must not be used directly or indirectly in anyway detrimental to the interest of the company.

Dimensions to be Controlled Within Limits as Shown
Machining Tolerance + 25 mm Unless Otherwise
Shown. Non Machining Tolerance ±

CARD CODE

DRAWING NO.

CHECKED

DRAWN

NAME

SIGN.

DATE

REF. TO ASSY. DRG. WESMAN

FA-8856-1

WEIGHT (KG)

SCALE

DEPT.

DESIGN H.

CODE

ITEM NO.

12

12.0

1:5

FA-8856-1

WESMAN

12

12.0

1:5

FA-8856-1

WESMAN

12

12.0

1:5

FA-8856-1

WESMAN

12

12.0

1:5

FA-8856-1

WESMAN

12

12.0

1:5

FA-8856-1

WESMAN

12

12.0

1:5

FA-8856-1

WESMAN

12

12.0

1:5

FA-8856-1

WESMAN

12

12.0

1:5

FA-8856-1

WESMAN

12

12.0

1:5

FA-8856-1

WESMAN

SHEET NO. 01

NO. OF SHEETS. 01

03, 27, 008

15 16 REV. 17

APPROVED

CHECKED

DRAWN

NAME

SIGN.

DATE

REF. TO ASSY. DRG. WESMAN

FA-8856-1

WEIGHT (KG)

SCALE

DEPT.

DESIGN H.

CODE

ITEM NO.

12

12.0

1:5

FA-8856-1

WESMAN

12

12.0

1:5

FA-8856-1

WESMAN

12

12.0

1:5

FA-8856-1

WESMAN

12

12.0

1:5

FA-8856-1

WESMAN

12

12.0

1:5

FA-8856-1

WESMAN

12

12.0

1:5

FA-8856-1

WESMAN

12

12.0

1:5

FA-8856-1

WESMAN

12

12.0

1:5

FA-8856-1

WESMAN

12

12.0

1:5

FA-8856-1

WESMAN

12

12.0

1:5

FA-8856-1

WESMAN

12

12.0

1:5

FA-8856-1

WESMAN

12

12.0

1:5

FA-8856-1

WESMAN

12

12.0

1:5

FA-8856-1

WESMAN

12

12.0

1:5

FA-8856-1

WESMAN

12

12.0

1:5

FA-8856-1

WESMAN

12

12.0

1:5

FA-8856-1

WESMAN

12

12.0

1:5

FA-8856-1

WESMAN

12

12.0

1:5

FA-8856-1

WESMAN

12

12.0

1:5

FA-8856-1

WESMAN

12

12.0

1:5

FA-8856-1

WESMAN

12

12.0

1:5

FA-8856-1

WESMAN

12

12.0

1:5

FA-8856-1

WESMAN

12

12.0

1:5

FA-8856-1

WESMAN

12

12.0

1:5

FA-8856-1

WESMAN

12

12.0

1:5

FA-8856-1

WESMAN

12

12.0

1:5

FA-8856-1

WESMAN

12

12.0

1:5

FA-8856-1

WESMAN

12

12.0

1:5

FA-8856-1

WESMAN

12

12.0

1:5

FA-8856-1

WESMAN

12

12.0

1:5

FA-8856-1

WESMAN

12

12.0

1:5

FA-8856-1

WESMAN

12

12.0

1:5

FA-8856-1

WESMAN

12

12.0

1:5

FA-8856-1

WESMAN

12

12.0

1:5

FA-8856-1

WESMAN

12

12.0

1:5

FA-8856-1

WESMAN

12

12.0

1:5

FA-8856-1

WESMAN

12

12.0

1:5

FA-8856-1

WESMAN

12

12.0

1:5

FA-8856-1

WESMAN

12

12.0

1:5

FA-8856-1

WESMAN

12

12.0

1:5

FA-8856-1

WESMAN

12

12.0

1:5

FA-8856-1

WESMAN

12

12.0

1:5

FA-8856-1

WESMAN

12

12.0

1:5

FA-885

FIRST ANGLE PROJECTION (ALL DIMENSIONS ARE IN mm)

REV	DATE	ALTERED	REV	DATE	ALTERED
		CHECKED			CHECKED

The information on this document is the property of BHARAT HEAVY ELECTRICALS LIMITED. It must not be used directly or indirectly in anyway detrimental to the interest of the company.

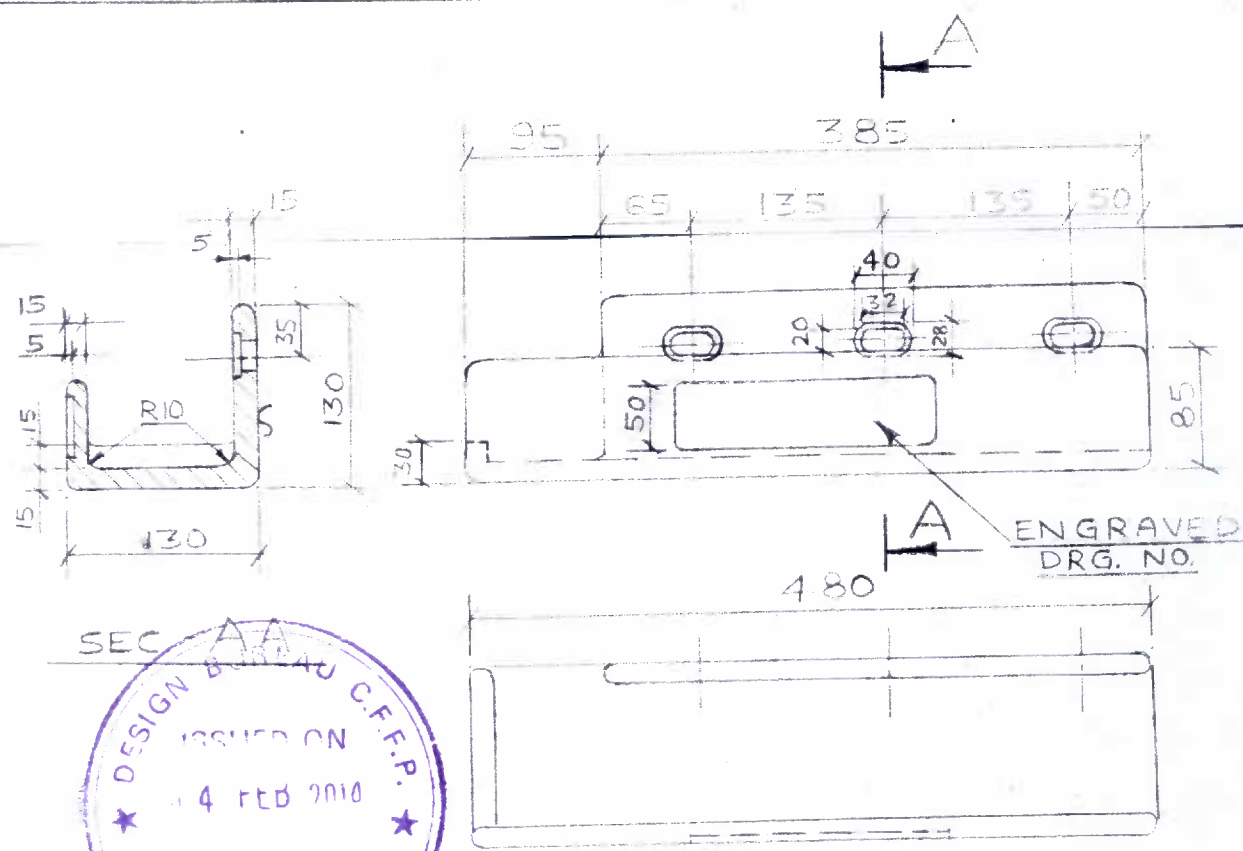

S. No.	USED IN	QTY. INSTALLED
1.	(8x4x2.85)M WESMAN H.T FURNACE (S. FDY.)	2

MATERIAL: CI HR
 C - 3.1% - 3.5%
 Si - 2% - 2.8%
 Ni - 0.8% - 1.2%
 CY - 1.5% - 2%



BHARAT HEAVY ELECTRICALS LTD.

UNIT: C.F.F.P., HARDWAR.

Inventory No. FFB121020034	Sign. & Date	DEPT. DESIGN	CODE	SCALE 1:5	WEIGHT (KG) 15.5	REF. TO ASSY. DRG. WESMAN FA 8856-1	ITEM NO. 449
		BOGIE SIDE SAND TROUGH CASTING				DRAWN KISHORILAL	CHECKED PARAG
Dimensions to be Controlled Within Limits as Shown Machining Tolerance + .25 mm Unless Otherwise Shown. Non Machining Tolerance ±						DRAWING NO. 03,27,004	15 16 REV. 17 0
CARD CODE						SHEET NO. 01	NO. OF SHEETS. 01

ENGRAVED
DRG No

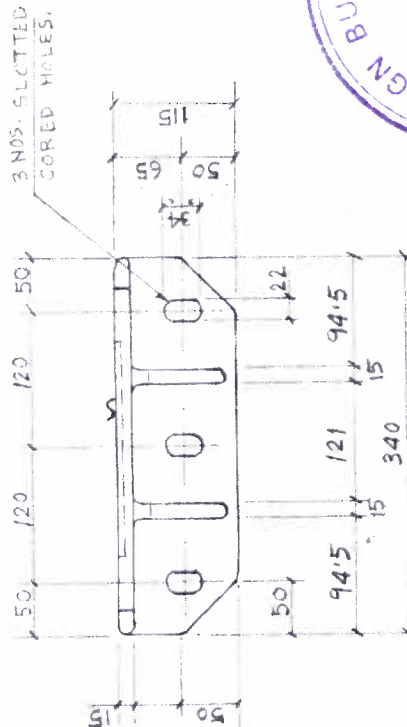
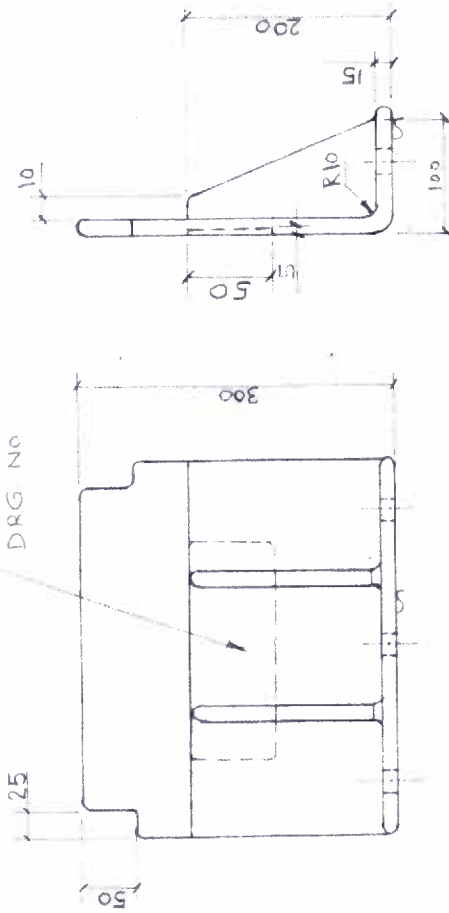

3 NOS. SLOTTED
CORED HOLES.

MATL: C.I., H.R.

C	3.1	7	-	3.5	7.
Si	2.0		-	2.0	
Mn	0.8		-	1.2	
Cr	1.5		-	2.0	

S. No	USED IN	QTY INSTALLED
1	18x4x2.85)M WEEMAN HIT FURNACE (S.FDY)	66

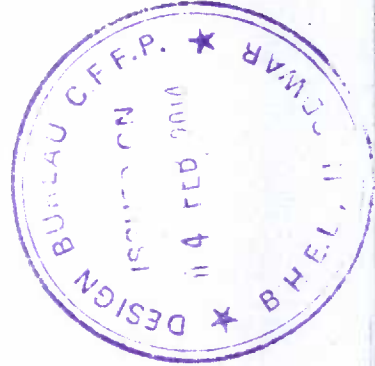

BHARAT HEAVY ELECTRICALS LTD.
UNIT : CENTRAL FOUNDRY FORGE PLANT.
HARDWAR.



DEPTT. DESIGN	SCALE 1:5	WEIGHT KGS 16.0	DESIGNER - FA-8856-1	PART NO. 2
TITLE	BOGIE SIDE CURB CASTING.			
DRAWN	WORKED	CHECKED	APPROVED	DATE
DRAWING NO. 03/27,002 Ro			SHEET NO. 1	
NO. OF SHEETS 1			SIZE A3	

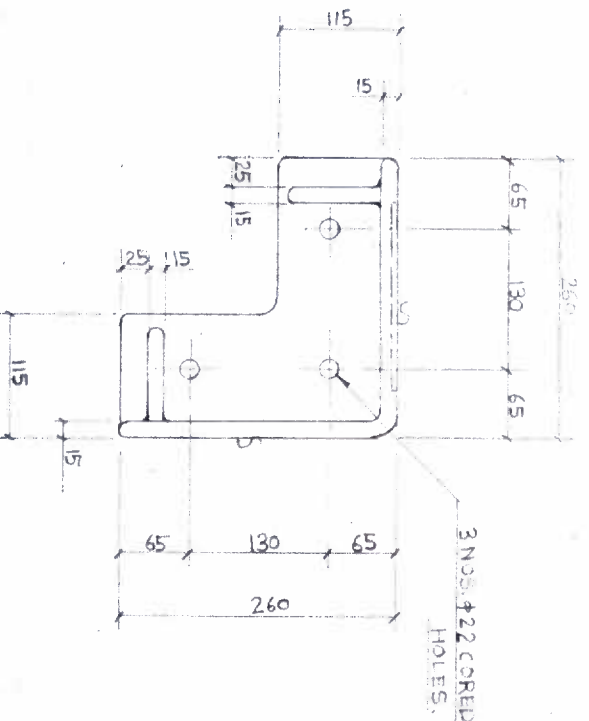
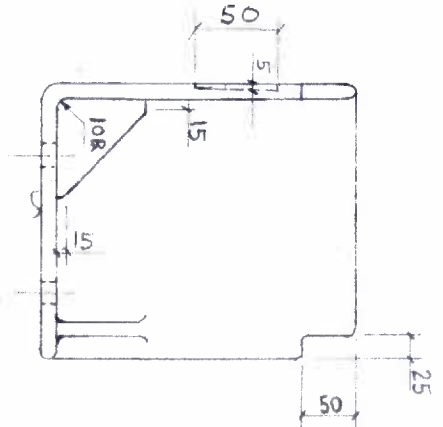
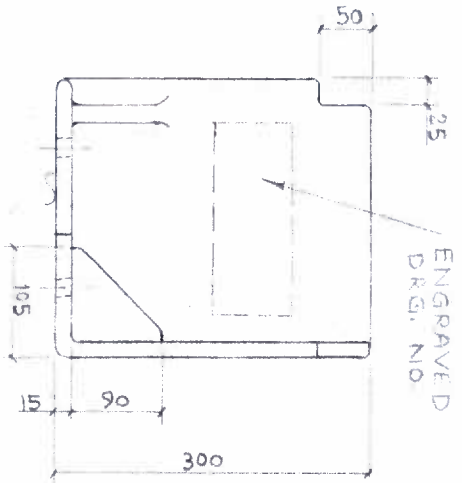

MATERIAL: C.I.H.R.	
C	3.1 % - 3.5 %
Si	2.0 - 2.8
Mn	0.8 - 1.2
Cr	1.5 - 2.0

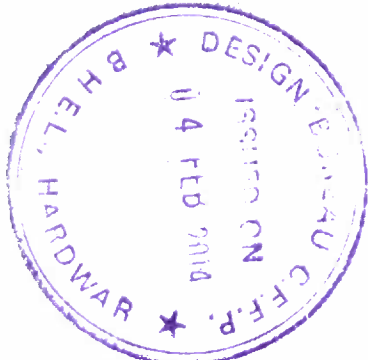

S. NO.	USED IN	QTY INSTALLED
1	(8 X 4 X 2.85) M WELDMAN HT FURNACE	4

BHARAT HEAVY ELECTRICALS LTD.
UNIT : CENTRAL FOUNDRY FORGE PLANT.
HARDWARE.

DEPT	DESIGN	SCALE	1:5	WEIGHT (KGS)	23.0
TITLE	BOGIE CORNER CURB CASTING				
DRW	ASOK KUMAR	CHKD	KISHORILAL	APPROVED	PARAG GUPTA
WORKED		CHECKED		DRAWING NO.	02/27/001
				SHEET NO.	01
				NO OF SHEETS	01

THE INFORMATION ON THIS DOCUMENT IS THE PROPERTY OF BHARAT HEAVY ELECTRICALS LIMITED. IT MUST NOT BE USED DIRECTLY OR INDIRECTLY IN ANY WAY DETERIMENTAL TO THE INTEREST OF THE COMPANY.

110-03-80

DRAWING No.

FIRST ANGLE PROJECTION

(ALL DIMENSIONS ARE IN mm)

FORM 06 3/81

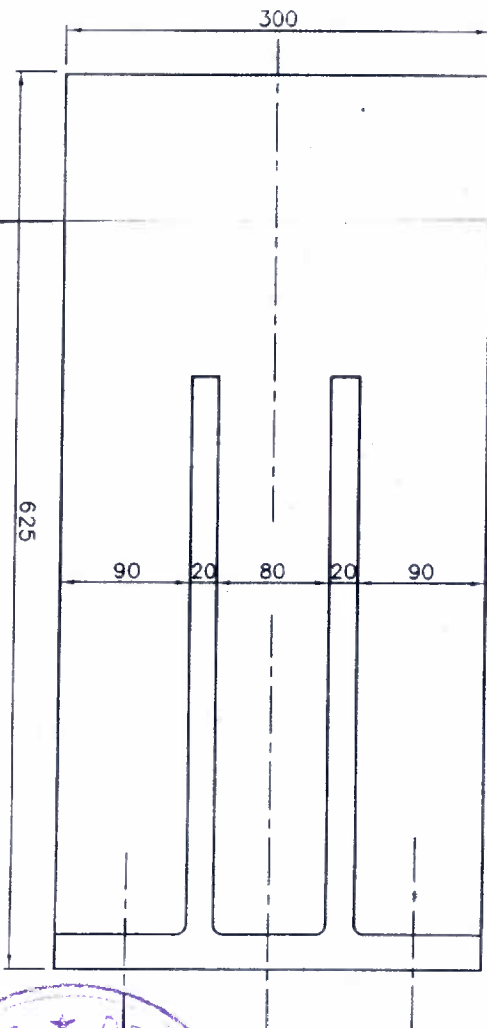
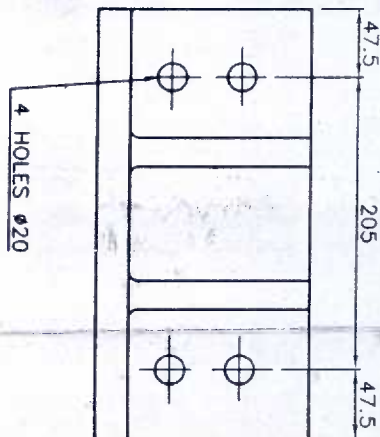
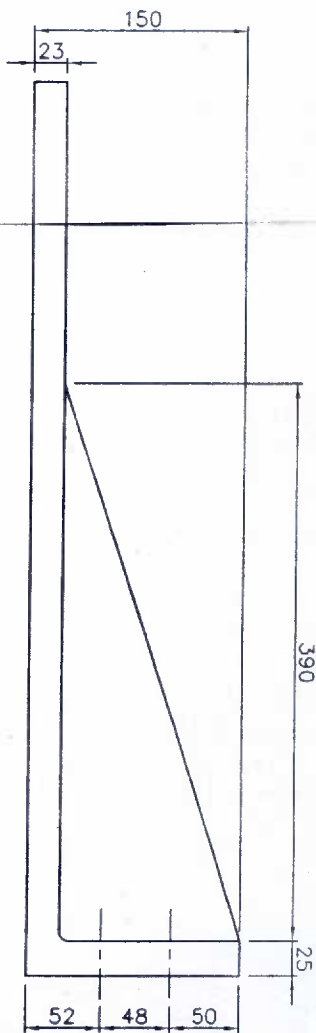

MATERIAL - HEAT RESISTANT
CAST IRON

C - 3.1-3.5
Si - 2.0-2.8
Ni - 0.8-1.2
Cr - 1.5-2.0



Inventory No. FF812020290 Sign & Date Ref. Drawing No.

REV	DATE	ALTERED	CHECKED

REV	DATE	ALTERED	CHECKED

REV	DATE	ALTERED	CHECKED

MATERIAL:

		BHARAT HEAVY ELECTRICALS LTD. UNIT: CENTRAL FOUNDRY FORCE PLANT RANIPUR, HARDWAR	
DEPT CODE	SCALE	WEIGHT (KG)	CARD CODE
	NTS	49 KG	03-30-011
TITLE: TOP COLUMN CASTING FOR 100T FURNACE (S.FDY)		REF. TO ASSY. DRG.	DRAWING NO. 03-30-011 SHEET No. 1 No. OF SHEETS 1
DATE	DATE	DATE	NO. OF VAR
04.01.14	04.01.14	04.01.14	0

DRAWING No. 03-30-010

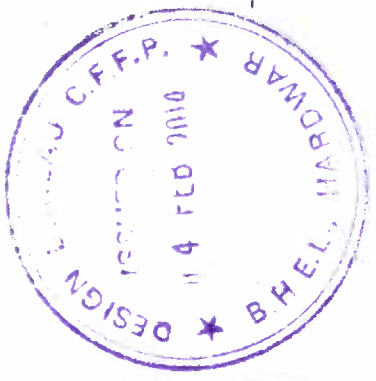
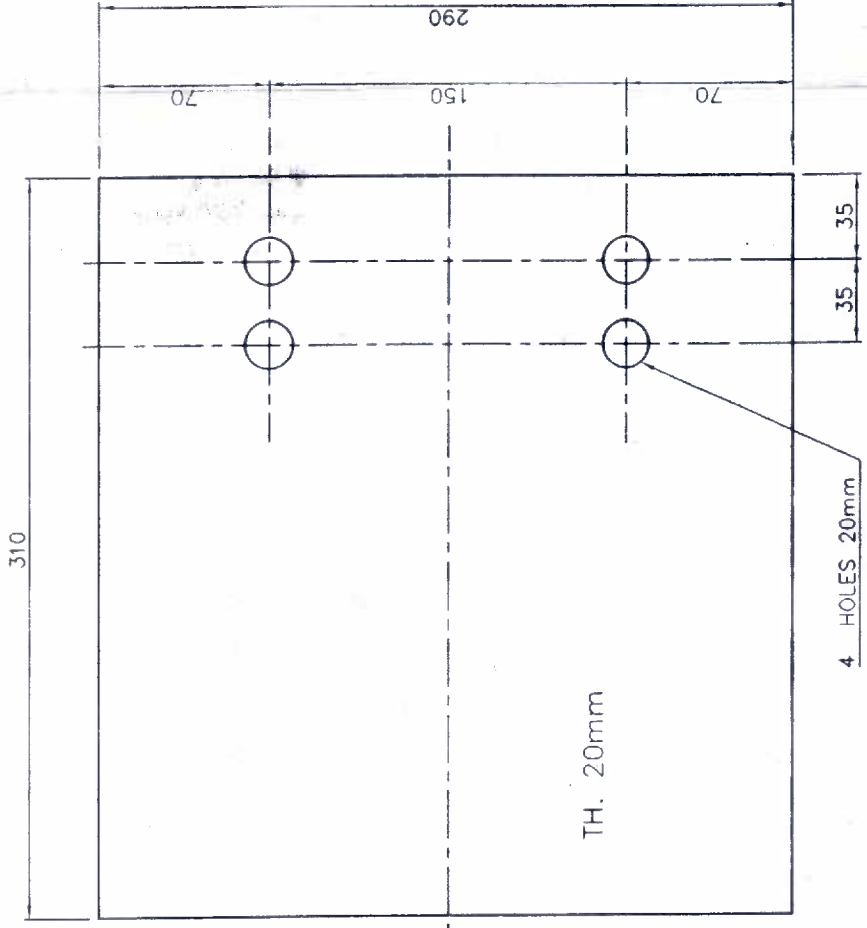

MATERIAL - HEAT RESISTANT
CAST IRON

- C - 3.1-3.5
- Si - 2.0-2.8
- Ni - 0.8-1.2
- Cr - 1.5-2.0

THE INFORMATION ON THIS DOCUMENT IS THE PROPERTY OF BHARAT HEAVY ELECTRICALS LIMITED. IT MUST NOT BE USED DIRECTLY OR INDIRECTLY IN ANY WAY DETERMINAL TO THE INTEREST OF THE COMPANY.

COPYRIGHT AND CONFIDENTIAL

Ref. Drawing No

Sign & Date

Inventory No
FF8121020271

		BHARAT HEAVY ELECTRICALS LTD.		DEPT	SCALE	WEIGHT (KG)	REF. TO ASSY. DRG.	NO. OF ITEMS
UNIT: CENTRAL FOUNDRY FORCE PLANT		RANIPUR, HARDWAR		CODE	NTS	14 KGS		75 77
TITLE : CASTING NO.2		SIDE COLUMN		REV	DATE	ALTERED	NO. OF SHEETS	75 74
FOR 100T FURNACE (S.FDY)				DATE	CHECKED		1	22/23 24
CARD CODE		DRAWING NO.		REV	DATE	ALTERED	1	0
7		03-30-010		DATE	CHECKED		1	0
SHEET No.		SHEET No.		REV	DATE	ALTERED	1	0
1		1		DATE	CHECKED		1	0

600-03-30

ON DIMENSIONS

4 HOLES $\phi 22$

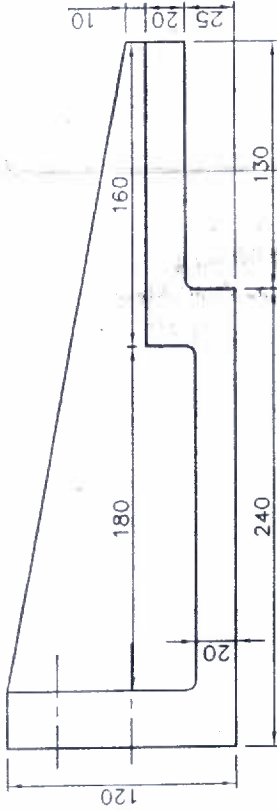
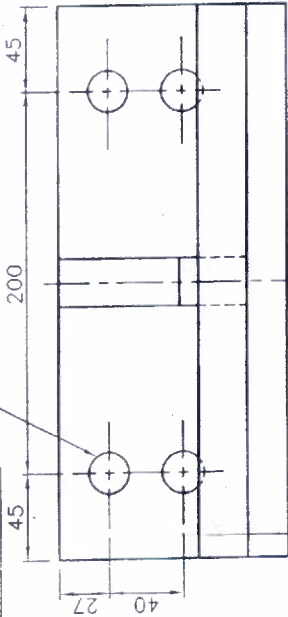

4 HOLES $\phi 20$

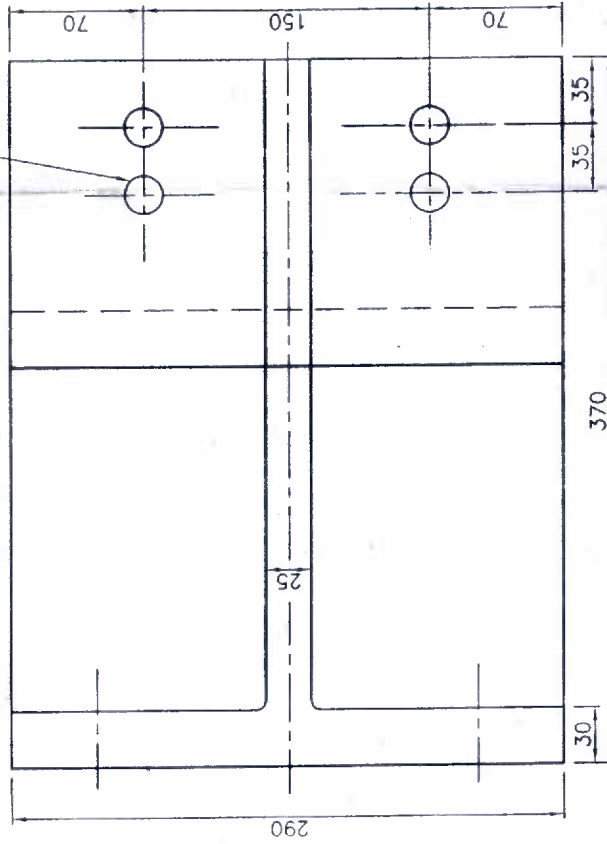

MATERIAL - HEAT RESISTANT
CAST IRON

- C - 3.1-3.5
- Si - 2.0-2.8
- Ni - 0.8-1.2
- Cr - 1.5-2.0

THE INFORMATION ON THIS DOCUMENT IS THE PROPERTY OF BHARAT HEAVY ELECTRICALS LIMITED. IT MUST NOT BE USED DIRECTLY OR INDIRECTLY IN ANY WAY DETERMINENTAL TO THE INTEREST OF THE COMPANY.

COPYRIGHT AND CONFIDENTIAL

Ref. Drawing No

Sign & Date

FF812102268
Inventory No

MATERIAL:

REV	DATE	ALTERED	CHECKED

DEPT
CODE



SCALE
NTS

WEIGHT (KG)
28 KGS

REF. TO ASSY. DRG.
ITEM No.

NO. OF
VAR

DATE
03.01.14

SIGN
K.LAL

NAME
K.LAL

DRN
K.LAL

CHD
PRAVEEN

APPR
ASHOK

DATE
22.01.14

NO. OF
ITEMS

75 77

NO. OF
ITEMS

75 77

TITLE : CASTING NO.1
OF SIDE COLUMN
FOR 100T FURNACE (S.FDY)

CARD
CODE

DRAWING NO.
03-30-009

NO. OF
ITEMS

22 23 24

NO. OF
ITEMS

0

SHEET No.

1

No. OF SHEETS

1

THE INFORMATION ON THIS DOCUMENT IS THE PROPERTY OF BHARAT HEAVY ELECTRICALS LIMITED. IT MUST NOT BE USED DIRECTLY OR INDIRECTLY IN ANY WAY DETERIMENTAL TO THE INTEREST OF THE COMPANY.

FIRST ANGLE PROJECTION

(ALL DIMENSIONS ARE IN mm)

FORM DC 36(B)

200-03-30

DRAWING No.

90

22.5

80

22.5

90

280

305

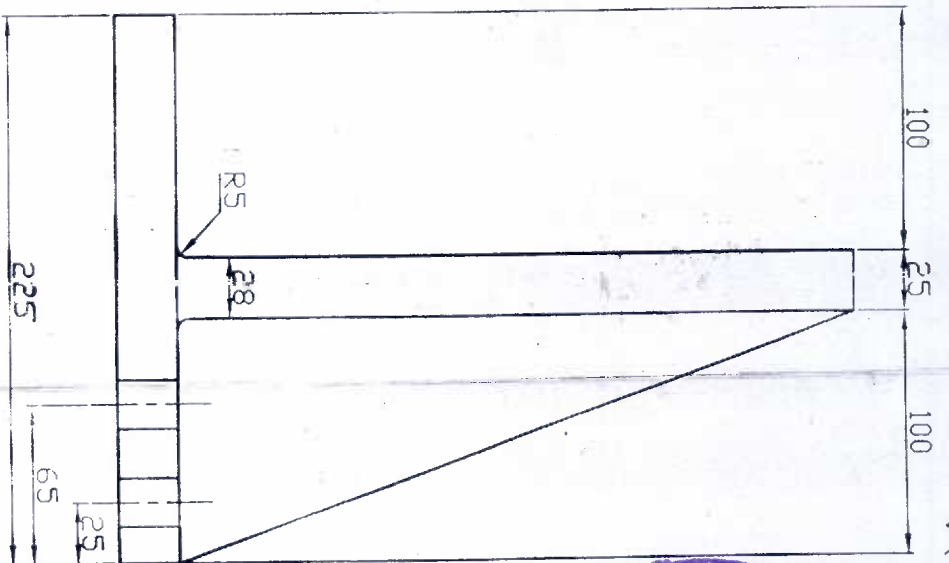
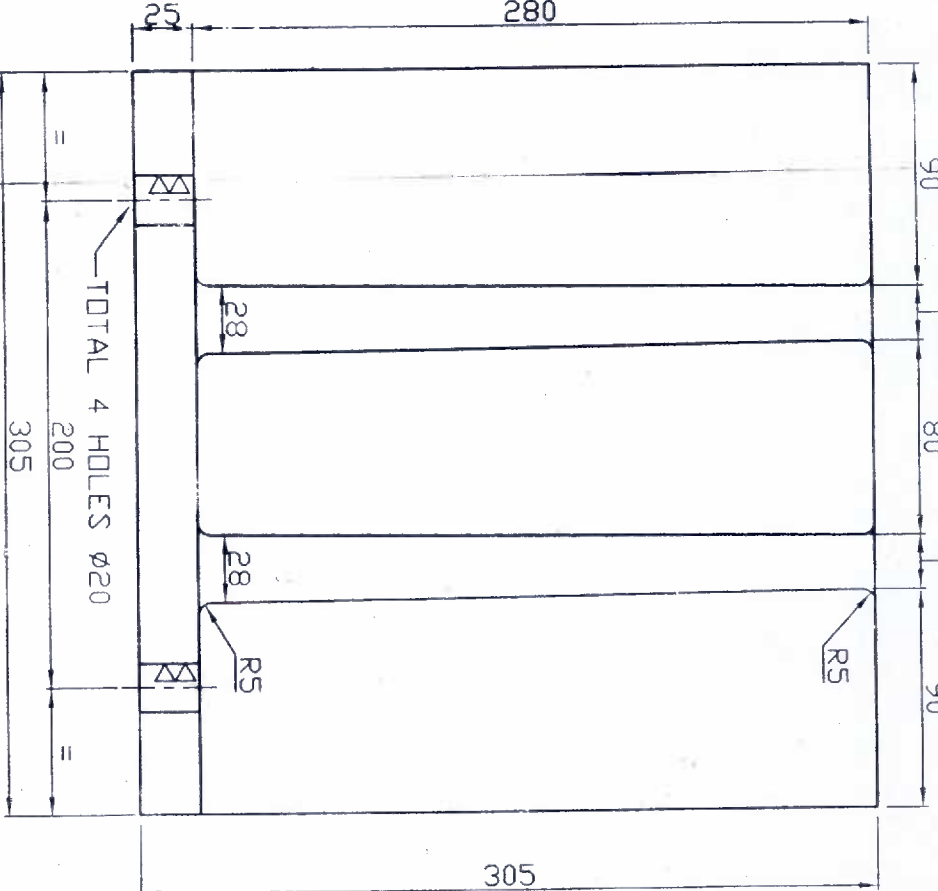

▽ (▽▽)

MATERIAL: HEAT RESISTANT C.I.

C	3.1%	3.5%
SI	2%	2.8%
NI	0.8%	1.2%
CR	1.5%	2%

MATERIAL:

FF8121020255
Inventory No. Sign & Date Ref. Drawing No.

REV	DATE	ALTERED	CHECKED

REV	DATE	ALTERED	CHECKED

REV	DATE	ALTERED	CHECKED

REV	DATE	ALTERED	CHECKED

REV	DATE	ALTERED	CHECKED

REV	DATE	ALTERED	CHECKED

REV	DATE	ALTERED	CHECKED

BHARAT HEAVY ELECTRICALS LTD.
 UNIT: CENTRAL POWDERY FORCE PLANT
 RANIPUR, HARDWAR

DEPT CODE: 1:2
 SCALE: 1:2
 WEIGHT (KG): 35.6

TITLE: **BOGIE CASTING**
 FOR 100T LPG FURNACE
 S.FDY.

CARD CODE: 03-30-002

DRAWING NO. 03-30-002

SHEET No. 1 / No. OF SHEETS 1

NAME	SIGN	DATE	NO. OF VAR
NISHU		16.01.13	
KESHORI LAL		16.01.13	

APPROVED: [Signature]

REF. TO ASSY. DRG. NO. 75 77



FIRST ANGLE PROJECTION (ALL DIMENSIONS ARE IN mm)

DRAWING NUMBER

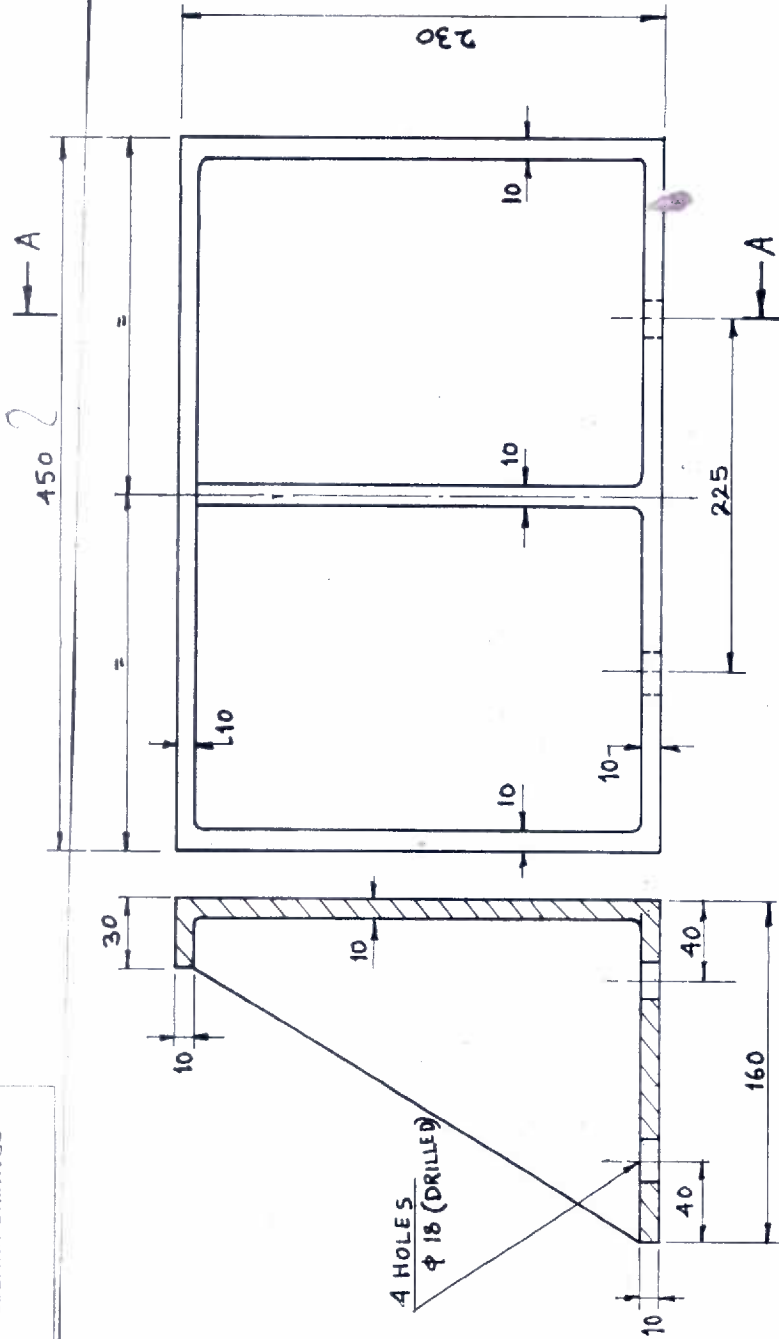

SECT. : A-A

*Pl check before
ordering*



TYPE OF PRODUCT
OR
CUSTOMER'S NAME



BHARAT HEAVY ELECTRICALS LTD.

C. F. F. P., RANIPUR - HARDWAR.

DEPT.	CODE	SCALE	WEIGHT (KG)	REF TO ASSY. DRG	ITEM NO.
		NT-3	16.190		
DOOR SIDE CASTING			DRAWN	NAME	SIGN
FOR VULCAN FURNACE			CHECKED	Ashok	Ashok
			APPROVED		18-12-09
Dimensions to be Controlled Within Limits as Shown			DRAWING NO.	01, 08, 008	R1
Machining Tolerance \pm 0.25 mm Unless Otherwise			SHEET NO.		
Shows. Non Machining Tolerance \pm			NO. OF SHEETS.		

C - 3.1% - 3.5%
Si - 2% - 2.8%
Ni - 0.8% - 1.2%
Cr - 1.5% - 2%

MATERIAL : C.I. (H.R.)

REV 1/12 ALTERED
1/10/09 CHECKED *Chandra*

M.T.L. CHANGED.

The information on this document is the property of BHARAT HEAVY ELECTRICALS LIMITED. It must not be used directly or indirectly in any way detrimental to the interest of the company.

03/F24/073 R1
Ref. Drg. No.

Sign. & Date

Inventory No.
PF8121020247

REV. DRAWING

FIRST ANGLE PROJECTION (ALL DIMENSIONS ARE IN mm.)

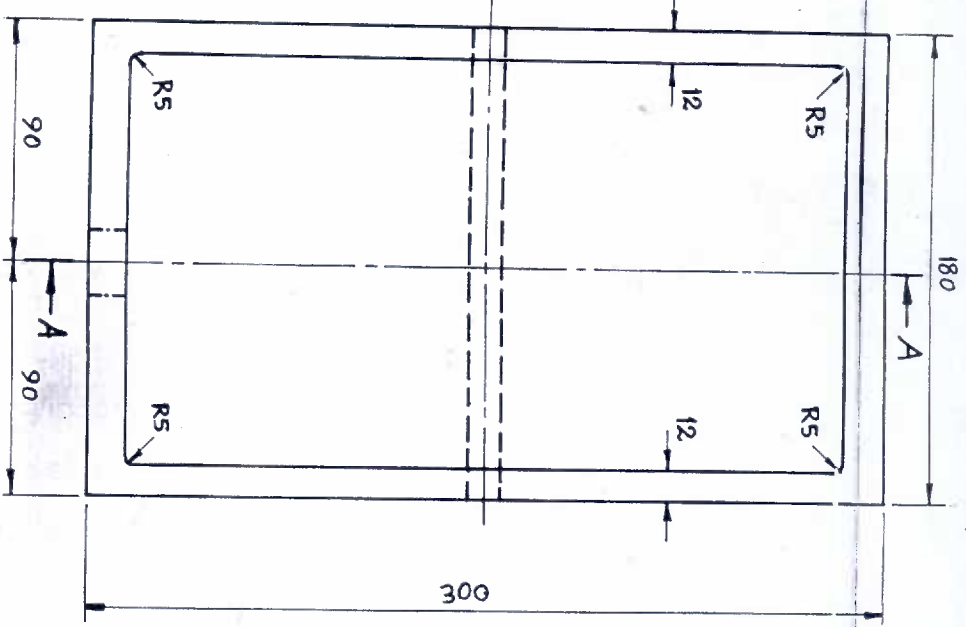
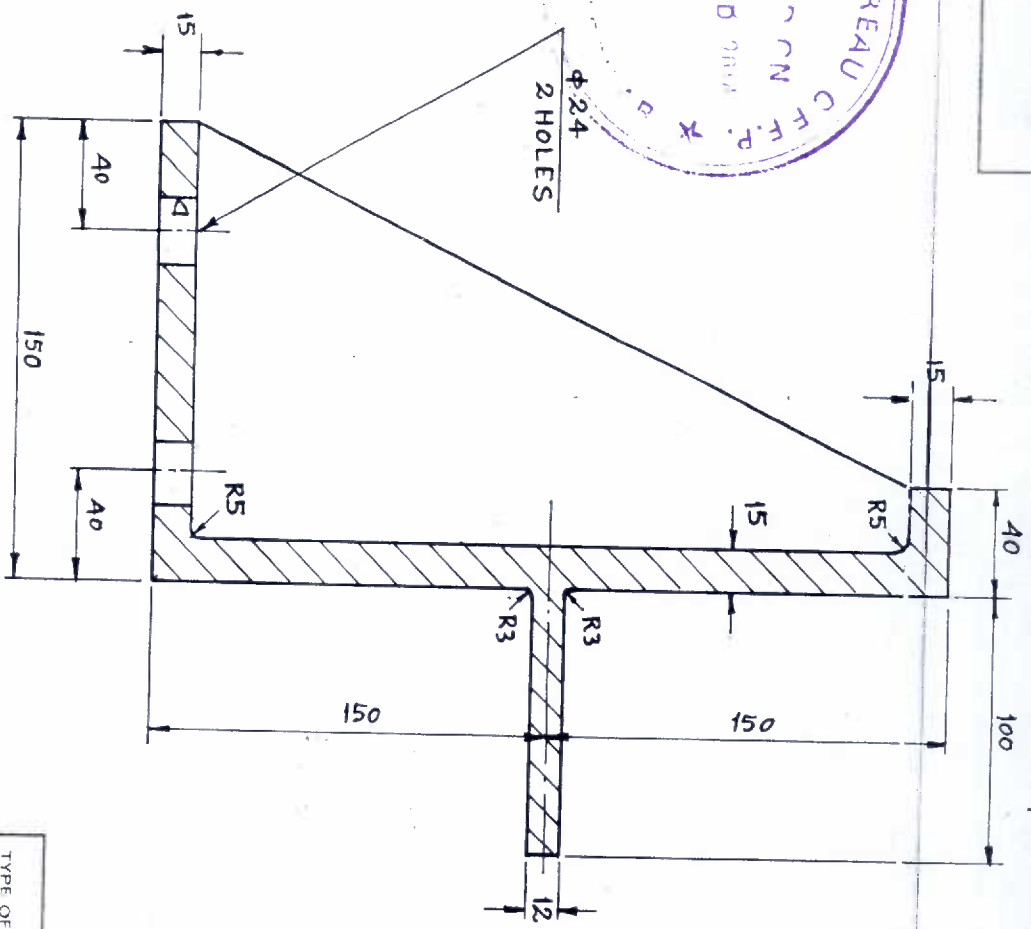
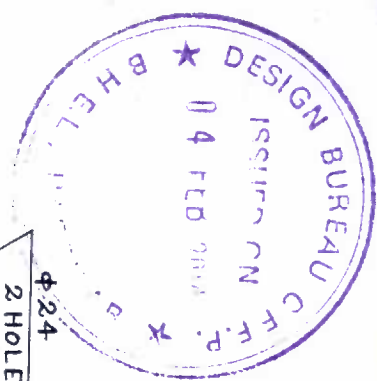

SEC. A-A

MATERIAL : C.I. (H.R.)

C - 3.1% - 3.5%
 Si - 2% - 2.8%
 Mn - 0.8% - 1.2%
 Cr - 1.5% - 2%

REV	DATE	ALTERED
R	5/10	CHECKED

MTL. CHANGED.

TYPE OF PRODUCT
 OR
 NAME OF CUSTOMER / PROJECT



BHARAT HEAVYELECTRICALS LTD.
 UNIT: C.F.F.P., HARDWAR.

DEPT. MAINT.	CODE	SCALE 1:2	WEIGHT (KG)	REF TO ASSY. DRG.	ITEM NO.
--------------	------	-----------	-------------	-------------------	----------

DOOR CASTING BOTTOM
 (VULCAN FURNACE)

Dimensions to be Controlled Within Limits as Shown
 Machining Tolerance + 25 mm Unless Otherwise Shown, Non Machining Tolerance ±

CARD CODE	DRAWING NO. 01,08,024	1516 REV. 1
SHEET NO. 1	NO. OF SHEETS 1	DATE

FF812102023J
 Inventory No.

Sign. & Date

Ref. Drg. No.

The information on this document is the property of BHARAT HEAVY ELECTRICALS LIMITED. It must not be used directly or indirectly in anyway detrimental to the interest of the company.

FIRST ANGLE PROJECTION (ALL DIMENSIONS ARE IN mm)

REV.

REEMUN GUINWARD

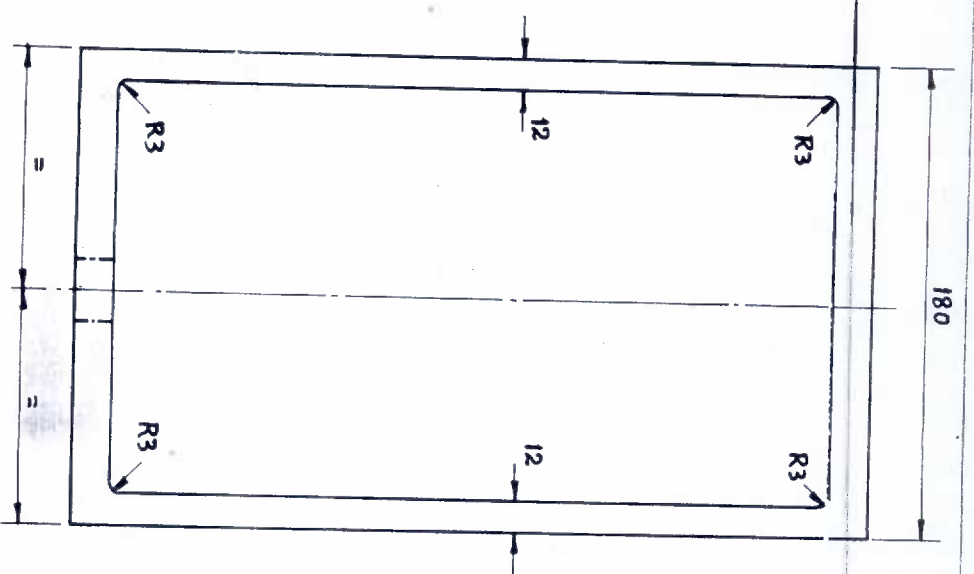
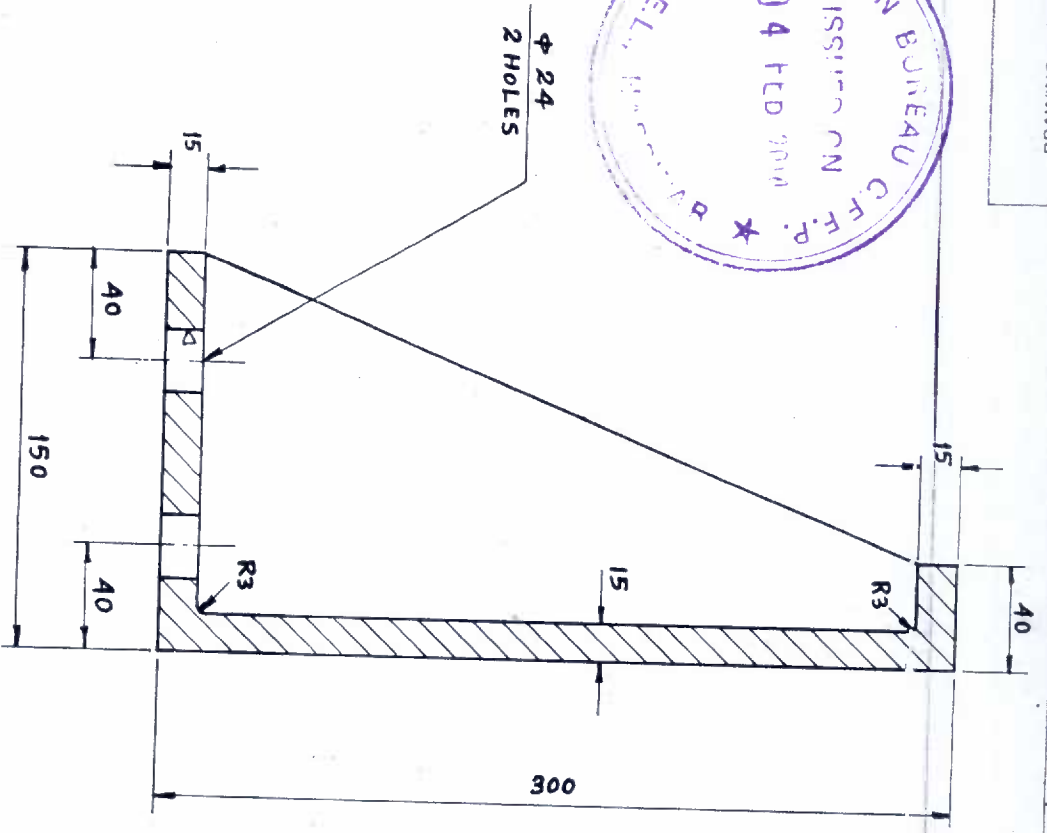
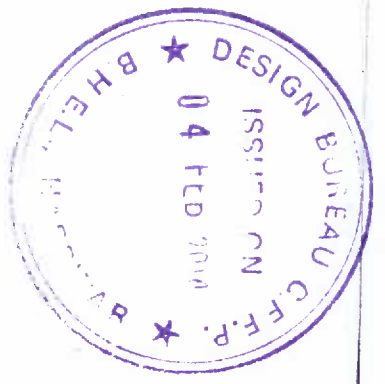

MATERIAL : C.I. H.R. Wt. 0.8% - 1.2%
 C - 3.1% - 3.5%
 S - 2% - 2.8%
 CY - 1.5% - 2%

FF8121020220

Inventory No. Sign. & Date Ref. Drg. No.

The information on this document is the property of BHARAT HEAVY ELECTRICALS LIMITED. It must not be used directly or indirectly in any way detrimental to the interest of the company.

REV	DATE	ALTERED
R1	1/10	CHECKED

MTL. CHANGED.

TYPE OF PRODUCT OR NAME OF CUSTOMER / PROJECT

BHARAT HEAVY ELECTRICALS LTD.

UNIT: C.F.F.P., HARDWAR.

DEPT. MAINT. CODE

SCALE 1:2

WEIGHT (KG)

REF TO ASSY. DRG.

DRAWN NAME

CHECKED NAME

APPROVED NAME

DATE

DOOR CASTING TOP BD-7
 (FOR VULCAN FURNACE)

Dimensions to be Controlled Within Limits as Shown
 Machining Tolerance + .25 mm Unless Otherwise
 Shown, Non Machining Tolerance ±

CARD CODE

DRAWING NO. 01, 08, 023

NO. OF SHEETS 1

REV. 1

FFB121020213

Inventory No.

Sign. & Date

03/F24/068 R₁

Ref. Drg. No.

The information on this document is the property of BHARAT HEAVY ELECTRICALS LIMITED. It must not be used directly or indirectly in anyway detrimental to the interest of the company.

DRAWING MEMBER

FIRST ANGLE PROJECTION (ALL DIMENSIONS ARE IN mm)

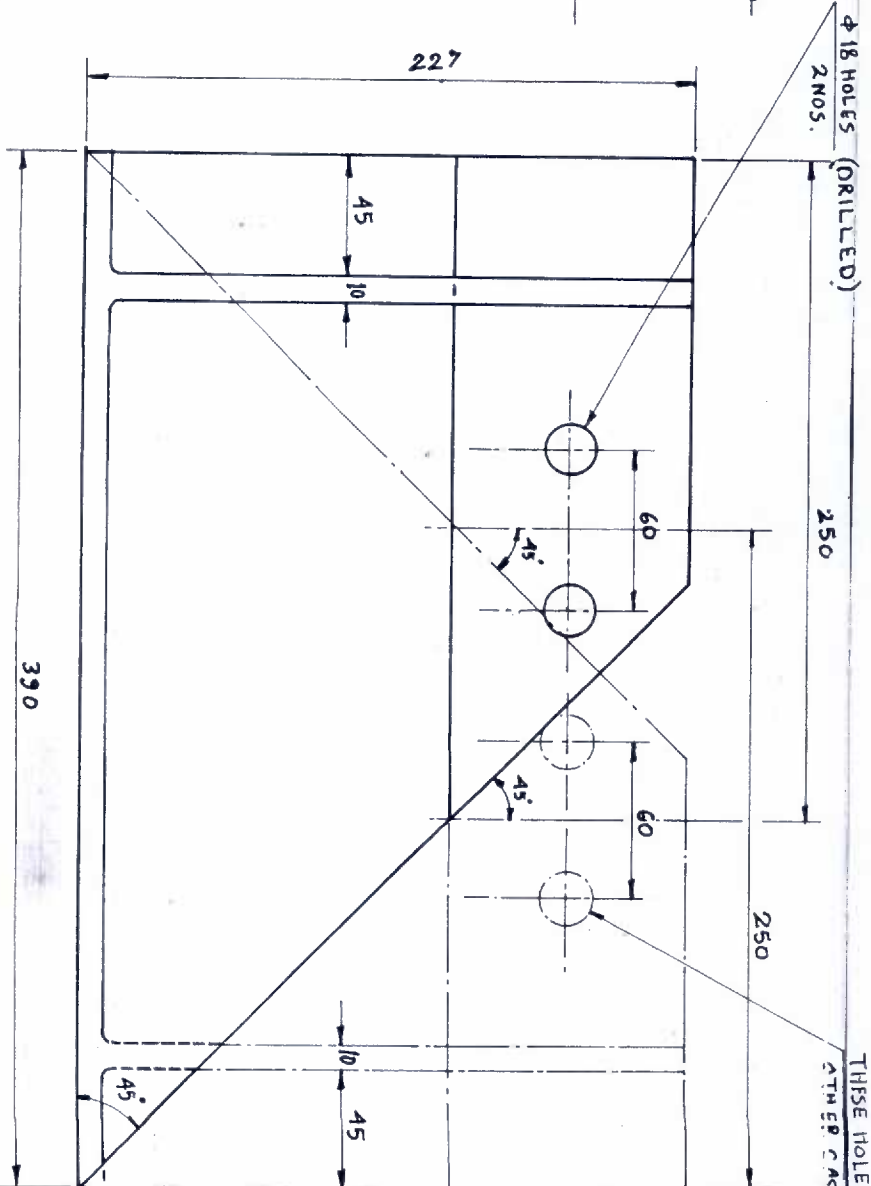
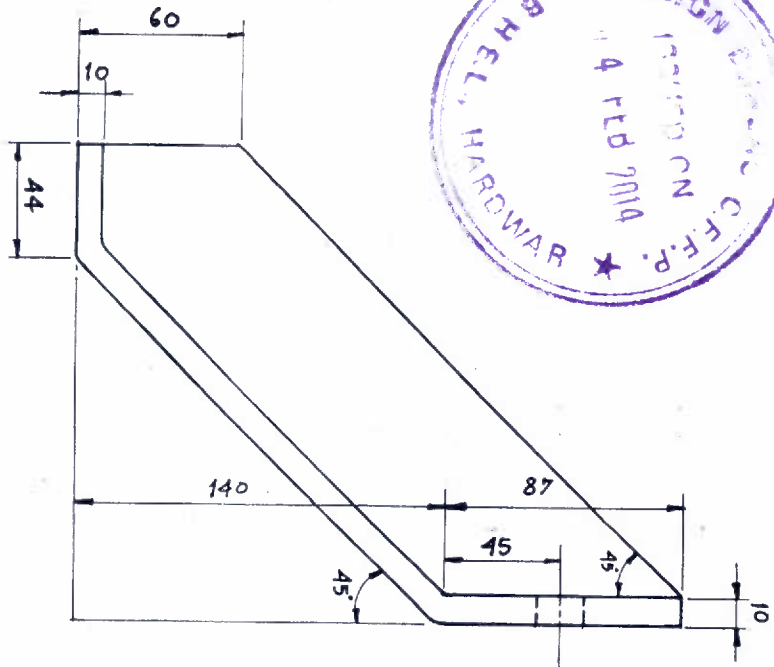
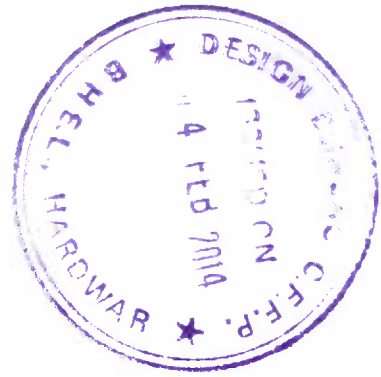

1. MATERIAL : C.I. (HR)
 2. CHAIN DOTTED LINES ARE SHOWN FOR R.H. CASTING.
- C - 3.1% - 3.5%
 Si - 2% - 2.8%
 Ni - 0.8% - 1.2%
 Cr - 1.5% - 2%

REV	DATE	ALTERED
R1	19/10	Checked

MTL. CHANGED.

TYPE OF PRODUCT
OR
CUSTOMER'S NAME

BHARAT HEAVY ELECTRICALS LTD.
C. F. F. P., RANIPUR - HARDWAR.

DEPT.	CODE	SCALE	WEIGHT (KG)	REF. TO ASSY DRG.	ITEM NO.
		1:2	4.724		

BOGIE HOLDING CORNER CASTING FOR VOLCAN FURNACE.

Dimensions to be Controlled Within Limits as Shown
 Machining Tolerance ± 25 mm Unless Otherwise Shown. Non Machining Tolerance ±

CARD CODE	DRAWING NO.	DATE
	01, 08, 005	13-11-75

HEARTH SEAL CASTING

REBUNUN GINWAWD

FIRST ANGLE PROJECTION (ALL DIMENSIONS ARE IN mm)

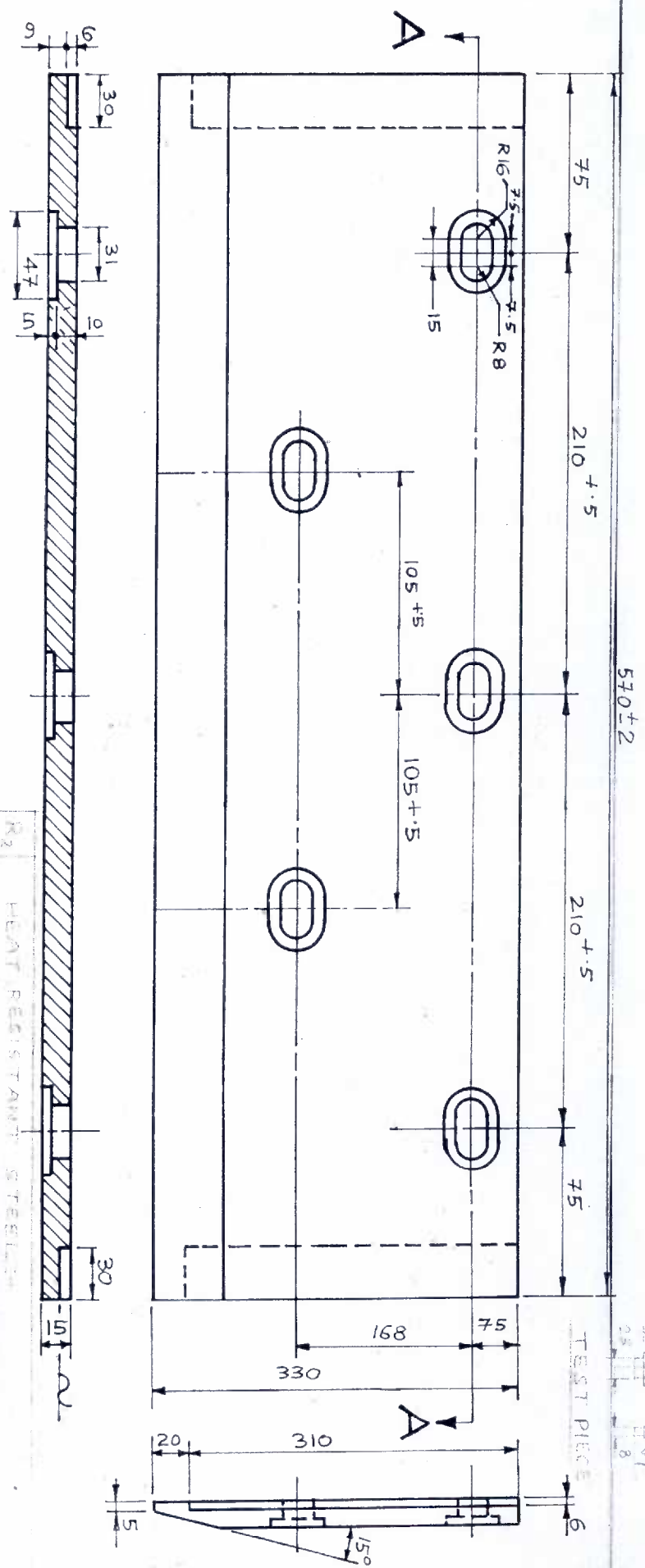

SECTION A-A

MATERIAL: HEAT RESISTANT CI.

C. 3.12-35.1
SI-22-287
NI-067-127
CI-157-27

NOTE: SURFACES MARKED WITH U TO BE SMOOTH FINISHED BY SHOT BLASTING OR GRINDING.
TEST PIECE MAY BE CAST INTEGRALLY AT ANY SUITABLE / CONVENIENT PLACE OF EACH CASTING

FF8121011094 312145 WESMAN FURNACE The information on this document is the property of BHARAT HEAVY ELECTRICALS LIMITED. It must not be used directly or indirectly in anyway detrimental to the interest of the company.

REV	DATE	ALTERED	CHECKED
2	3/3/2017	17.3.81	SWAMINATHAN

DEPT.	CODE	SCALE	N.T.S.	WEIGHT (KG)	22.00
SIDE SEAL CASTING (TYPE-I)					
10M X 7M FURNACE					
DIMENSIONS TO BE CONTROLLED WITHIN LIMITS AS SHOWN					
MACHINING TOLERANCE ± 25 mm UNLESS OTHERWISE SHOWN					
NON MACHINING TOLERANCE ±					
DRAWING NO. 01,01,017					
NO. OF SHEETS / 2					

BHARAT HEAVY ELECTRICALS LTD.
C.F.F.P. RANIPUR - HARDWAR.

DESIGN BUREAU
14 FEB 2014

FF8151920165
Inventory No.

Sign & Date

Ref. Dwg. No.

The information on this document is the property of BHARAT HEAVY ELECTRICALS LIMITED. It must not be used directly or indirectly in anyway detrimental to the interest of the company.

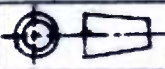
DEPT. DESIGN	SCALE 1:5	WEIGHT (KGS.)	REF. to DRG. DHANRAJ IND. CORP.	NAME SIGN	DATE
					
SQUARE CASTING		LPG 30T HT FURNACE S.C. YARD		DRAWN	
				CHECKED	
				APPROVED	
				S.K. GUPTA	
				K. LAL	
				05.13.004	
				REV. 0	
				SHEET NO. 1	
				NO. OF SHEETS	
				SIZE A4	

BHARAT HEAVY ELECTRICALS LTD.
UNIT: CENTRAL FOUNDRY FORGE PLANT.
HARDWAR.



HEAT RESISTANT C.I.	
C	3.1 - 3.5
S	2.0 - 2.8
N	0.8 - 1.2
Q	1.5 - 2.0

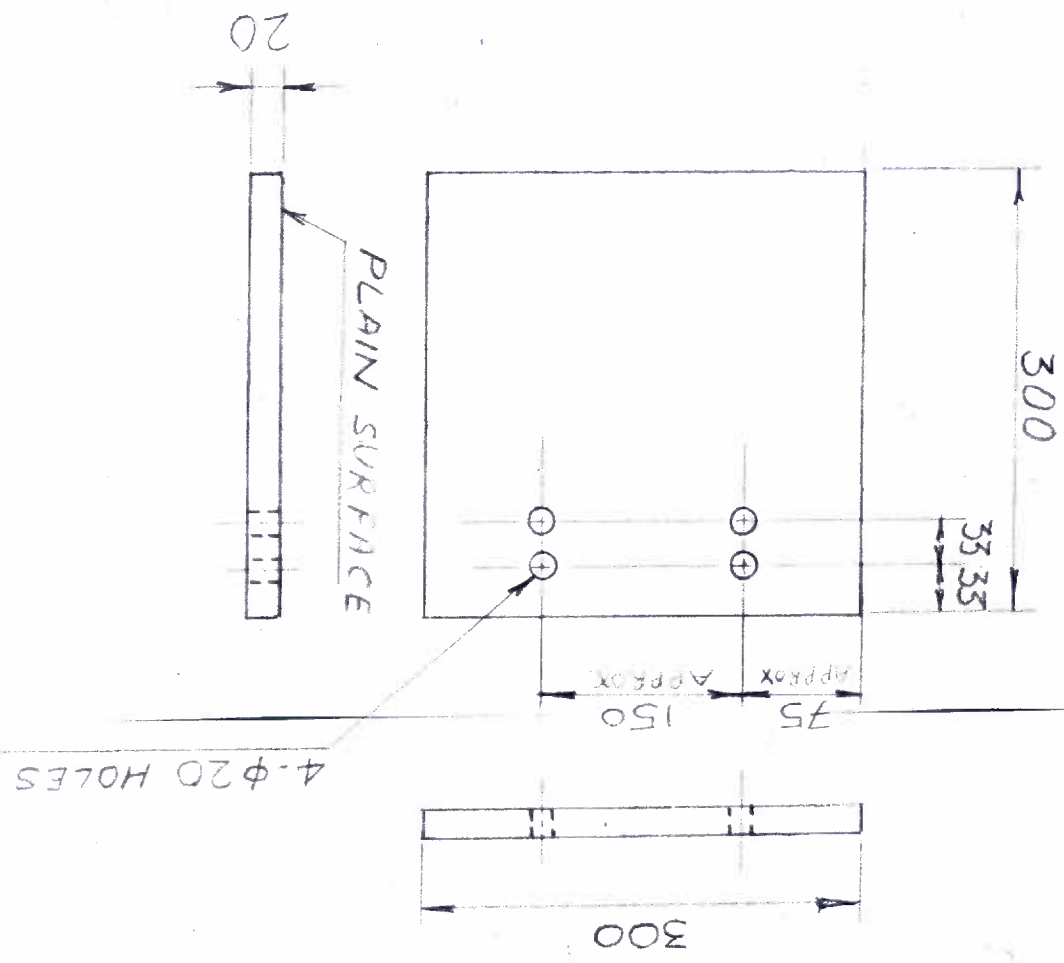

FIRST ANGLE PROJECTION (ALL DIMENSIONS ARE IN MM)

REV.	DATE	ALTERED	CHECKED
REV.	DATE	ALTERED	CHECKED

The information on this document is the property of BHARAT HEAVY ELECTRICALS LIMITED. It must not be used directly or indirectly in any way detrimental to the interest of the company.

Inventory No: FF8151920181
 Sign & Date: _____
 Ref. Drg. No: _____

REV.	DATE	ALTERED	CHECKED

MATERIAL: HEAT RESISTANT C.I.
 C = 3.1 - 3.5, S = 2.0 - 2.8
 M = 0.8 - 1.2, CR = 1.5 - 2.0

REV.	DATE	ALTERED	CHECKED

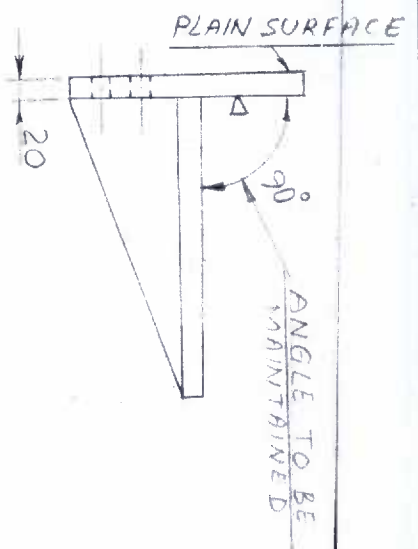
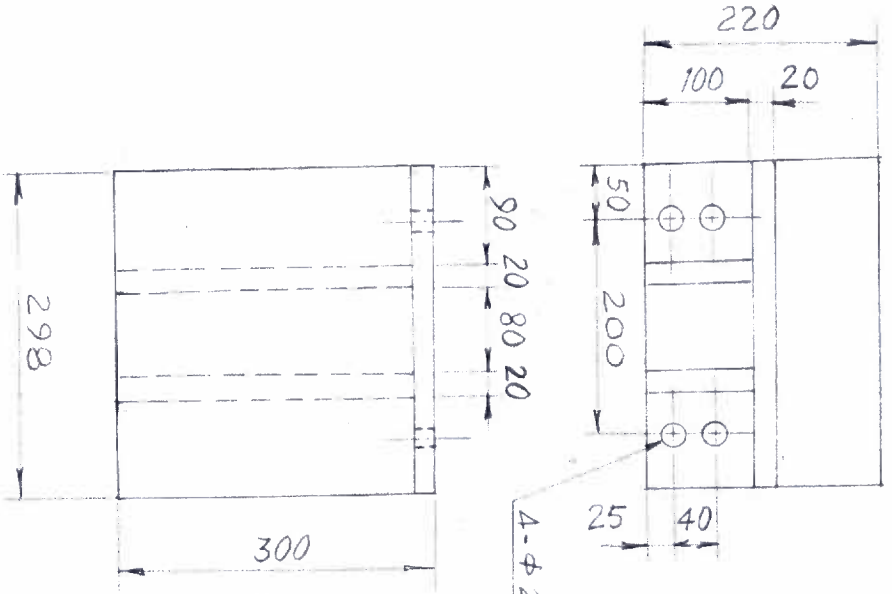

FIRST ANGLE PROJECTION (ALL DIMENSIONS ARE IN MM)

CORE FOR HOLES

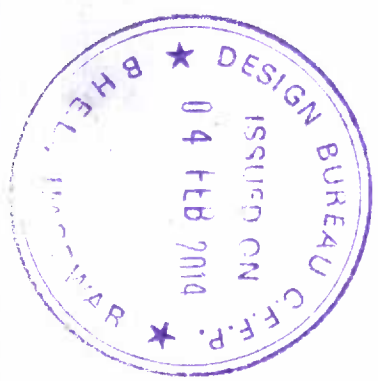

BHARAT HEAVY ELECTRICALS LTD.
 UNIT : CENTRAL FOUNDRY FORGE PLANT
 HARDWAR

DEPTT DESIGN: T-CASTING
 SCALE: 1:5
 TITLE: LPG, 30T HT FURNACE SCYARD

DRW: DHRUPAKASH IND CORP.
 CHK: K.LAL
 APP: SKS

DRAWING NO: 05/13,001
 SHEET NO: 1
 NO. OF SHEETS: 1

The information on this document is the property of BHARAT HEAVY ELECTRICALS LIMITED. It must not be used directly or indirectly in anyway detrimental to the interest of the company.

Inventory No. **FF8151920173** Sign & Date Ref. Drg. No.

REV	DATE	ALTERED	CHECKED

REV	DATE	ALTERED	CHECKED

REV	DATE	ALTERED	CHECKED

CORE FOR HOLES
 MATERIAL HEAT RESISTANT C.J.
 C = 3.1-3.5 ; S₁ = 2.0-2.8
 M₁ = 0.8-1.2 ; C₁ = 1.5-2.0

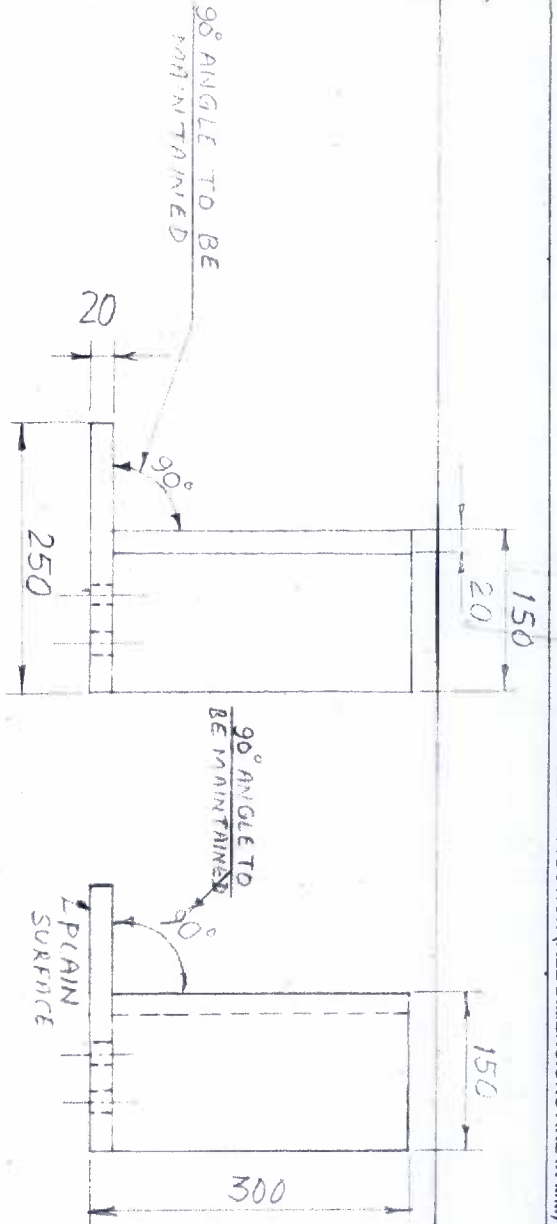
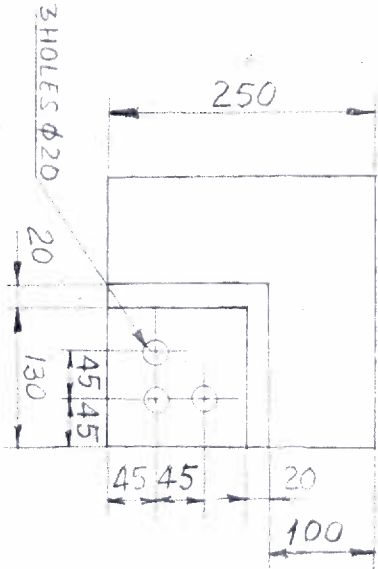

FIRST ANGLE PROJECTION (ALL DIMENSIONS ARE IN MM)



BHARAT HEAVY ELECTRICALS LTD.
 UNIT : CENTRAL FOUNDRY FORGE PLANT
HARDWAR

DEPTT DESIGN	SCALE 1:5	WEIGHT (KGS)	REF TO ASSY DRG	ITEM NO.
TITLE CORNER CASTING			DRAWN BY K.L.AT	DATE 26.05.11
			CHECKED BY S.K.GURU	DATE 23.06.11
			APPROVED BY	DATE

Dimensions to be Controlled Within Limits as Shown
 Machining Tolerance ± 0.25 mm Unless Otherwise Shown. Non Machining Tolerance ±

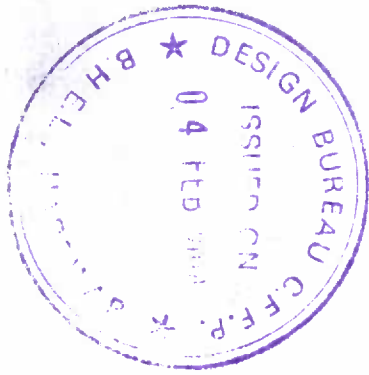

DRAWING NO. 05,13,002	NO. OF SHEETS 1
REV	

FF 8151930020

Inventory No.

Sign. & Date

Ref. Drg. No.

The information on this document is the property of BHARAT HEAVY ELECTRICALS LIMITED. It must not be used directly or indirectly in anyway detrimental to the interest of the company.

DRAWING NUMBER

FIRST ANGLE PROJECTION

(ALL DIMENSIONS ARE IN MM)

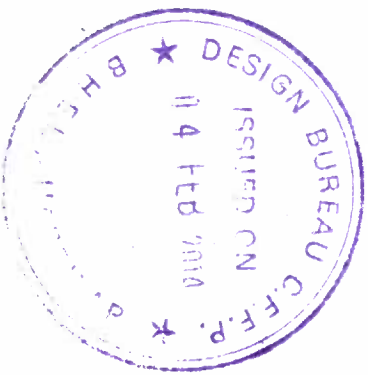
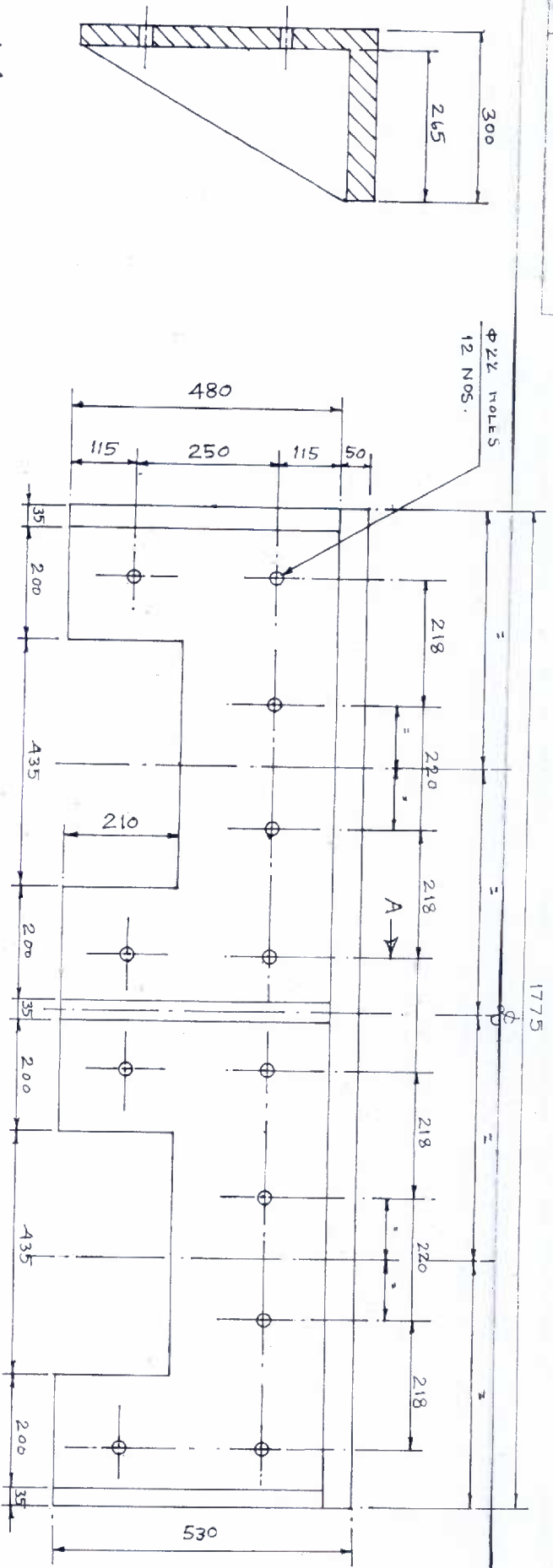

MATERIAL: CAST-IRON - GR-20

TYPE OF PRODUCT OR NAME OF CUSTOMER / PROJECT



BHARAT HEAVY ELECTRICALS LTD.
UNIT: C.F.F.P., HARDWAR.

DEPT. FE. CODE SCALE 1:8 WEIGHT (kg) 4450 kg REF TO ASSY. DRG. ITEM NO.

FOR HEAT TREATMENT FURNACE - CIF.

Dimensions to be Controlled Within Limits as Shown
Machining Tolerance + .25 mm Unless Otherwise Shown, Non Machining Tolerance ±

REV	DATE	ALTERED	CHECKED

CARD CODE	SHEET NO.	NO. OF SHEETS
05 - 111-002		

NAME	SIGN.	DATE

FF8121060184
FF8121060192
Inventory No.

FOR ITEM 1
FOR ITEM 2
Sign. & Date

Ref. Drg. No.

The information on this document is the property of BHARAT HEAVY ELECTRICALS LIMITED.
It must not be used directly or indirectly in anyway detrimental to the interest of the company.

REV.

DRAWING NUMBER

FIRST ANGLE PROJECTION (ALL DIMENSIONS ARE IN mm)

MTL. H.R.C.I. C - 3.1% to 3.5%
Si - 2% to 2.8%
Ni - 0.8% to 1.2%
Cr - 1.5% to 2%

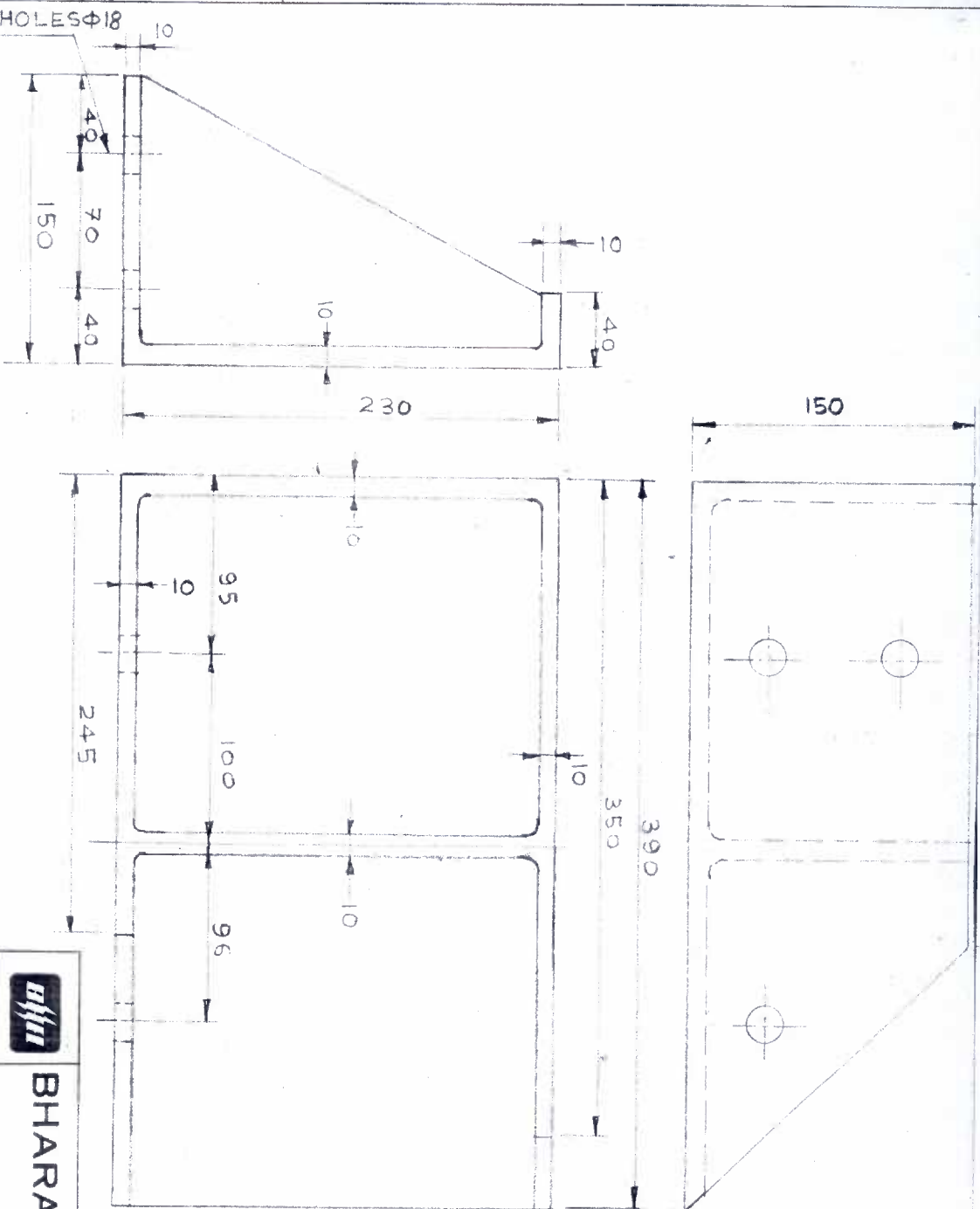

ITEM NO.1

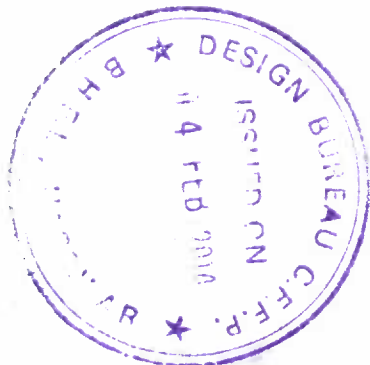

ITEM NO 2 IS MIRROR IMAGE
OF ITEM NO.1

BHARAT HEAVY ELECTRICALS LTD.
UNIT: C.F.F.P., HARDWAR.

DEPT.	CODE	SCALE	WEIGHT (KG)	REF. TO ASSY. DRG.	ITEM NO.
		1:2.5	13 ~		

DOOR CORNER CASTING (TOP)
STEEL FOUNDRY

Dimensions to be Controlled Within Limits as Shown
Machining Tolerance + .25 mm Unless Otherwise
Shown, Non Machining Tolerance ±

CARD CODE	DRAWING NO.	NO. OF SHEETS
03,07,007	1518 REV. 1	01

FIRST ANGLE PROJECTION (ALL DIMENSIONS ARE IN MM)

DRAWING NUMBER

REV.

ITEM NO.1

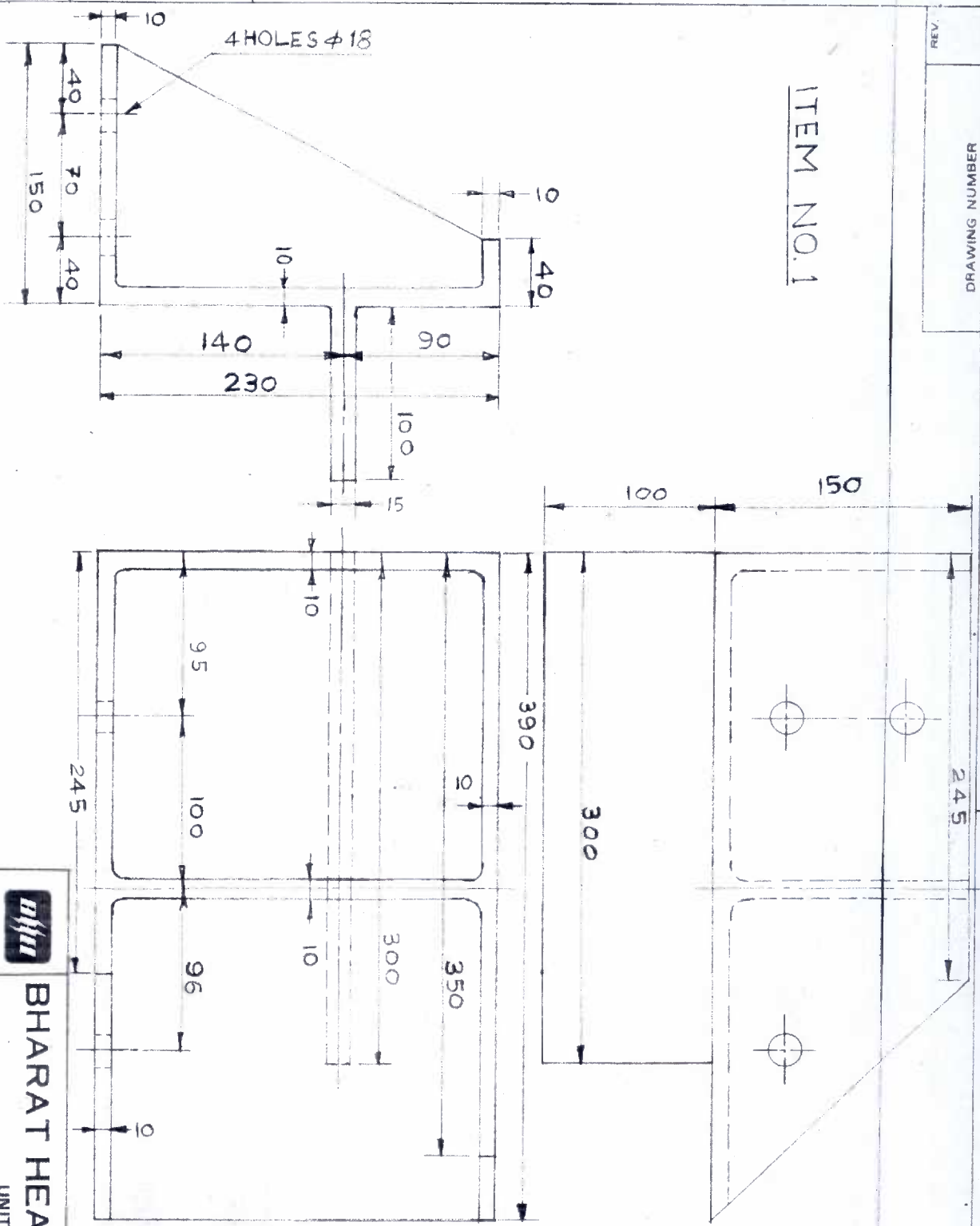

ITEM NO2 IS MIRROR
IMAGE OF ITEM NO.1

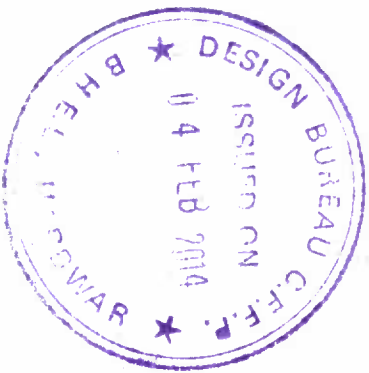

FF8121060206
FF8121060214
Inventory No.

FOR ITEM1
FOR ITEM2
Sign. & Date

Ref. Drg. No.

The information on this document is the property of BHARAT HEAVY ELECTRICALS LIMITED.
It must not be used directly or indirectly in anyway detrimental to the interest of the company.

MTL.H.R.C.I. C - 3.10% to 3.50%

Si - 2.80% to 2.80%
Ni - 0.80% to 1.20%
CY - 1.50% to 2.00%

REV	DATE	ALTERED
		CHECKED

BHARAT HEAVY ELECTRICALS LTD.
UNIT: C.F.F.P., HARDWAR.

DEPT. CODE SCALE WEIGHT (KG) REF. TO ASSY. DRG. ITEM NO.

DOOR LIP CORNER CASTING
STEEL FOUNDRY

Dimensions to be Controlled Within Limits as Shown
Machining Tolerance + 25 mm Unless Otherwise
Shown, Non Machining Tolerance ±

CARD CODE	DRAWING NO.	NO. OF SHEETS
	03,07,008	15
		16 REV. 1

FF8121060168
FF8121060170
Inventory No.

LARGER
SMALLER
Sign. & Date

Ref. Drg. No.

The information on this document is the property of BHARAT HEAVY ELECTRICALS LIMITED. It must not be used directly or indirectly in anyway detrimental to the interest of the company.

REV. _____
DRAWING NUMBER

FIRST ANGLE PROJECTION (ALL DIMENSIONS ARE IN mm.)

4 HOLES ϕ 18

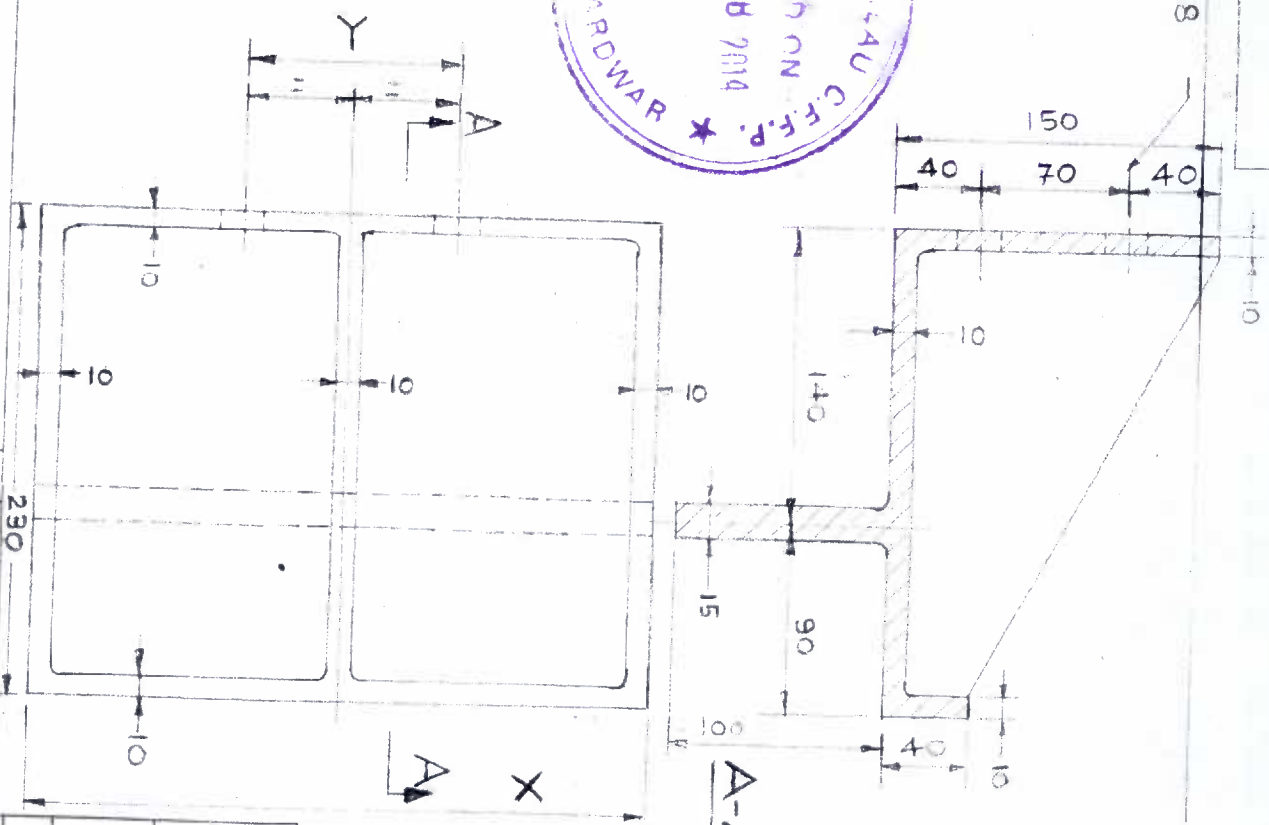

TABLE

DESCRIPTION	X	Y	W/T. IN KG
LARGER CASTING	390	200	21.25
SMALLER CASTING	290	100	17.15

MATERIAL: H.R. C.I. C-3.1% C, 0.3% Mn, 0.02% S, 0.005% P
Si - 2%, 0.6% Mn, 0.02% S, 0.005% P
Ni - 0.08%, 0.02% S, 0.005% P
Cr - 1.5%, 0.6% Mn, 0.02% S, 0.005% P

TYPE OF PRODUCT
OR
NAME OF CUSTOMER / PROJECT
BHARAT HEAVY ELECTRICALS LTD.
UNIT: C.F.F.P. HARDWAR.

DEPT. _____
CODE _____
SCALE N.T.S.
WEIGHT (KG) 21.25
DRAWING NO. 03,07,006
DATE 23/4/14

DOOR BOTTOM LIP CASTING
VULCAN HEAT TREATMENT
FURNACES
Dimensions to be Controlled Within Limits as Shown
Machining Tolerance + 25 mm Unless Otherwise Shown, Non Machining Tolerance +
CARD CODE 03,07,006
DRAWING NO. 03,07,006
SHEET NO. 01
NO. OF SHEETS. 01

FE8121060141 LARGER
 FE8121060150 SMALLER
 Inventory No.

Ref. Drg. No.

The information on this document is the property of BHARAT HEAVY ELECTRICALS LIMITED. It must not be used directly or indirectly in anyway detrimental to the interest of the company.

BHARAT HEAVY ELECTRICALS LTD.
 C.F.F.P., RANIPUR - HARDWAR.

DEPT. CODE SCALE WEIGHT (KG) REF. TO ASSY. DRG. ITEM NO.

FRONT WALL CASTING
 VULCAN FURNACE
 STEEL FOUNDRY

DIMENSIONS TO BE CONTROLLED WITHIN LIMITS AS SHOWN
 Machining Tolerance ± 25 mm Unless Otherwise Shown. Non Machining Tolerance \pm

DRAWING NO. 03,07,005
 REV. 0

SHEET NO. 01 NO. OF SHEETS, 01

APPROVED: K.K.K. (Signature)
 CHECKED: K.K.K. (Signature)
 DRAWN: M.K.G. (Signature)
 DATE: 24.8.77

SIZE A1

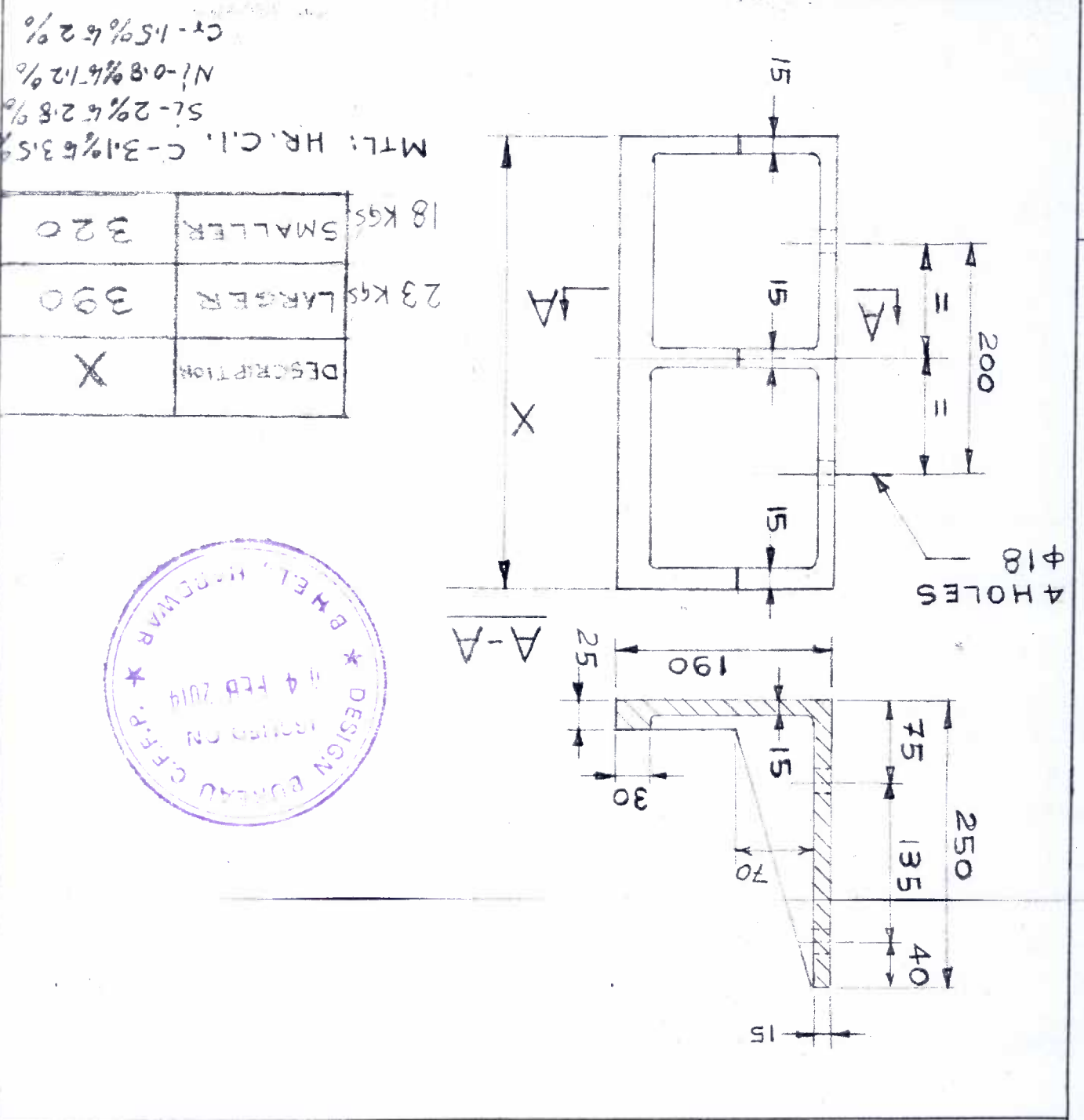

DESCRIPTION	18 Kgs	23 Kgs
SMALLER	320	390
LARGER		
X		



FIRST ANGLE PROJECTION (ALL DIMENSIONS ARE IN mm)

REV DATE	ALTERED	CHECKED
REV DATE	ALTERED	CHECKED

FIRST ANGLE PROJECTION (ALL DIMENSIONS ARE IN mm)

DRAWING NUMBER

REV.

The information on this document is the property of BHARAT HEAVY ELECTRICALS LIMITED. It must not be used directly or indirectly in anyway detrimental to the interest of the company.

03/134/073-F1

Sign. & Date

Inventory No.

418 HOLES - 4 NOS.

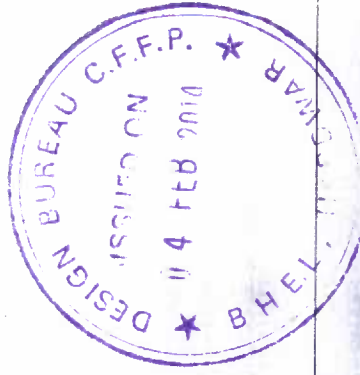
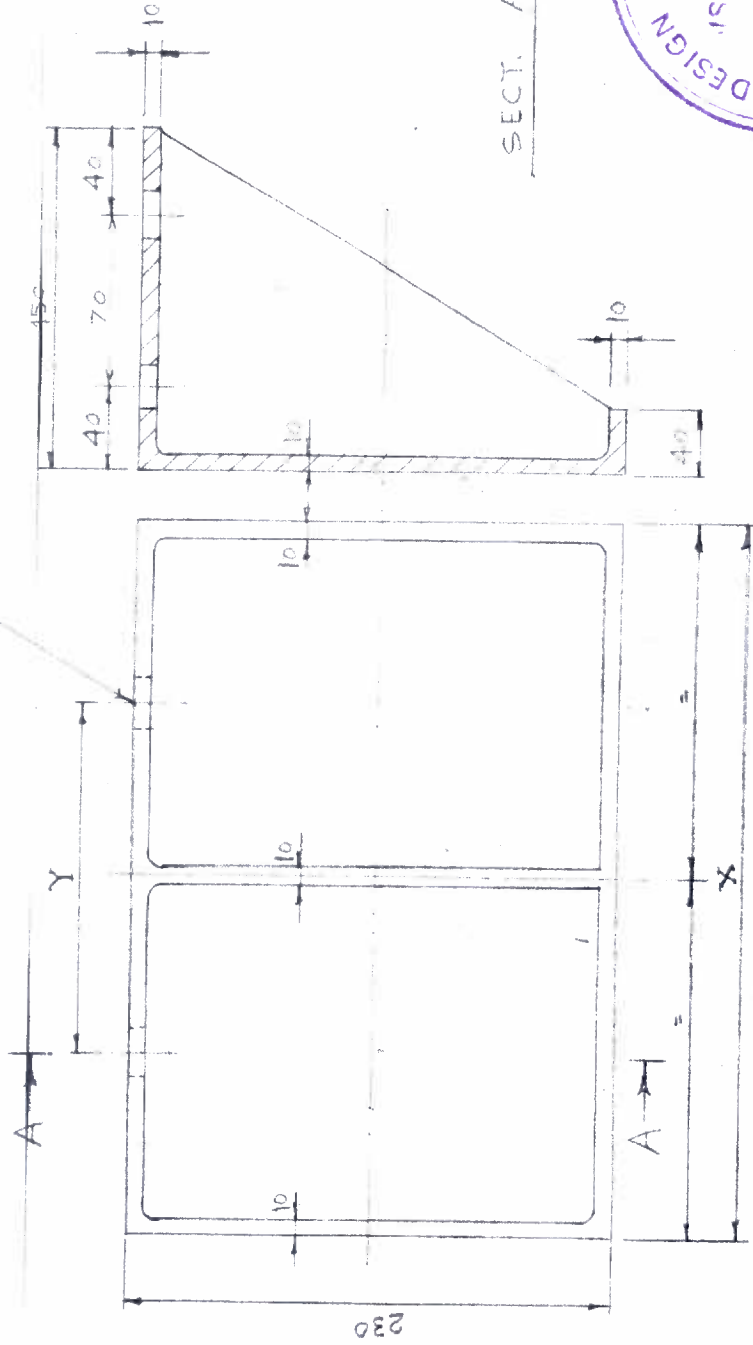

DESCRIPTION	X	Y	WT	INVENTORY NO
LARGER CASTING	390	200	17 KGS	FF8121060125
SMALLER CAST.	290	100	14 KGS	FF8121060133
MIDDLE CASTING	330	200		

MTL. HR. CT. C - 3.1% to 3.5%
 Si - 2% to 2.8%
 Ni - 0.8% to 1.2%
 Cv - 1.5% to 2%

TYPE OF PRODUCT
 OR
 NAME OF CUSTOMER / PROJECT



BHARAT HEAVYELECTRICALS LTD.
 UNIT: C.F.F.P., HARDWAR.

DEPT.	CODE	SCALE	WEIGHT (KG)	REF. TO ASSY. DRG.	ITEM NO.
			17.2		
REV.	DATE	ALTERED	CHECKED	NAME	DATE
				ASHOK	15/02/10
FOR VULCAN HEAT TREATMENT FURACES.			DRAWN	CHECKED	APPROVED
Dimensions to be Controlled Within Limits as Shown			DRAWING NO.	15	REV. 1
Machining Tolerance + .25 mm Unless Otherwise			CARD	03,07,004	0
Shown, Non Machining Tolerance ±			NO. OF SHEETS	01	

SIZE A3

FIRST ANGLE PROJECTION (ALL DIMENSIONS ARE IN mm)

DRAWING NUMBER
REV.

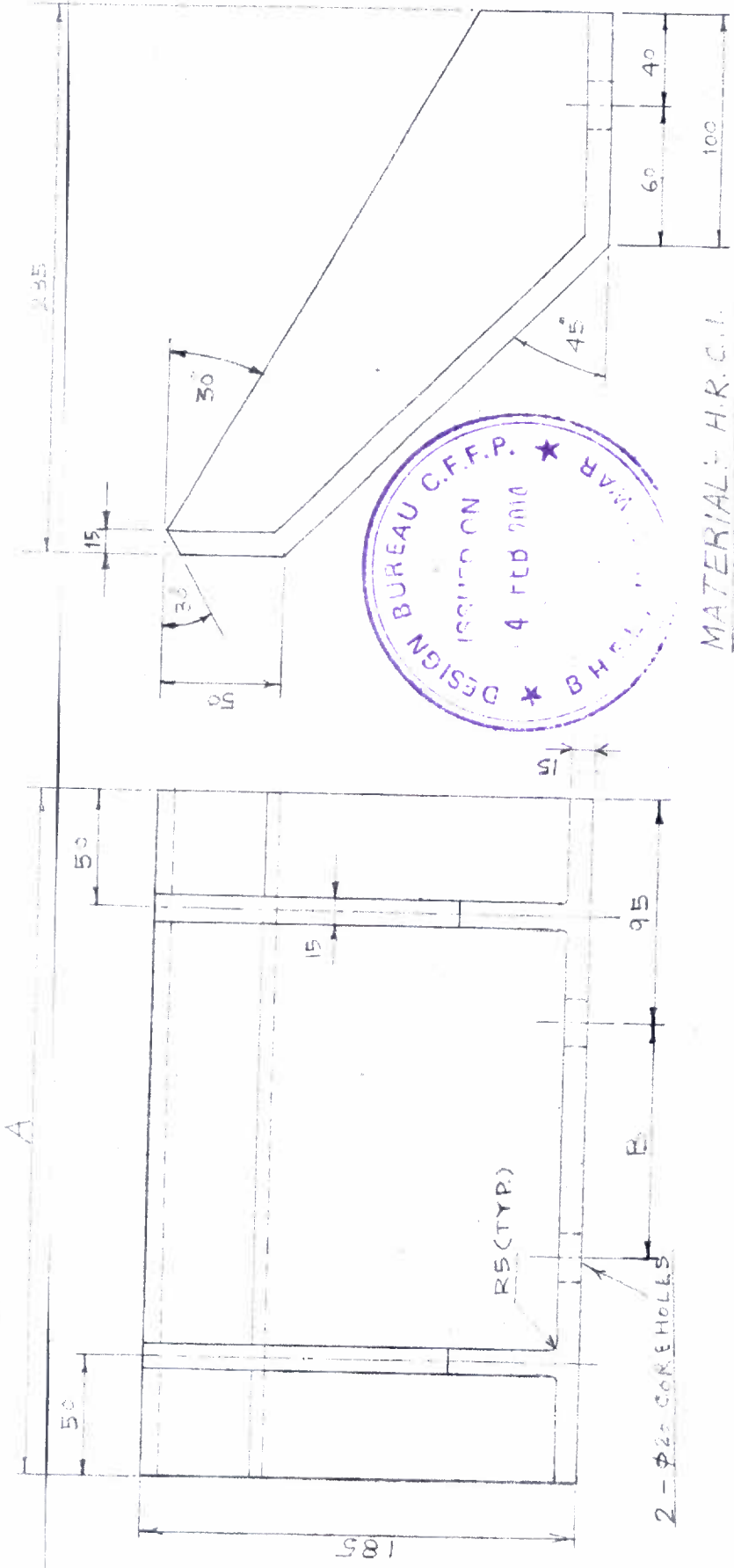

MATERIAL: H.R.C.I.
C - 31% TO 3.5%
Si - 2.0% TO 2.8%
Mn - 0.8% TO 1.2%
CY - 1.5% TO 2.0%

NO	INVENTORY NO.	A	B	QTY.	WT./KG.
2C	CASTING	FF8121060397	390	200	16.80
3C	CASTING	FF8121060494	290	100	13.30

Inventory No.	Sign. & Date	Rev. Date	ALTERED	ALTERED
		R1 19/08	Checked	Checked
THICKNESS CHANGED 10 mm TO 15 mm		MTL CHANGED		

TYPE OF PRODUCT		OR		NAME OF CUSTOMER / PROJECT	
BHARAT HEAVYELECTRICALS LTD.		UNIT: C.F.F.P., HARDWAR.			
DEPT. F.I.E.	CODE	SCALE	WEIGHT (KG)	REF TO ASSY. DRG.	ITEM NO.
		1:2	11.2	77/3	402
DRAWN			NAME		
CHECKED			SIGN.		
DATE			DATE		
25-4-87			25-4-87		
DRAWING NO.				NO. OF SHEETS	
01-08-028				02	
CARD CODE				REV.	
Dimensions to be Controlled Within Limits as Shown				15	
Machining Tolerance + 25 mm Unless Otherwise Shown, Non Machining Tolerance ±					

The information on this document is the property of BHARAT HEAVY ELECTRICALS LIMITED. It must not be used directly or indirectly in any way detrimental to the interest of the company.

510/CRS/12-2
20/30
01-08-028-1212

The information on this document is the property of BHARAT HEAVY ELECTRICALS LIMITED. It must not be used directly or indirectly in anyway detrimental to the interest of the company.

REV.

DRAWING NUMBER

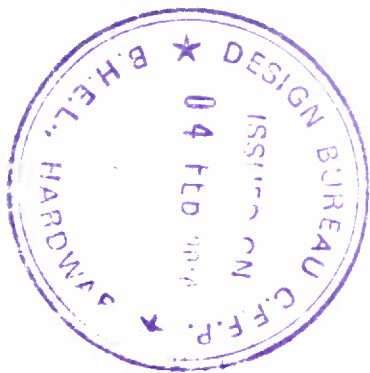
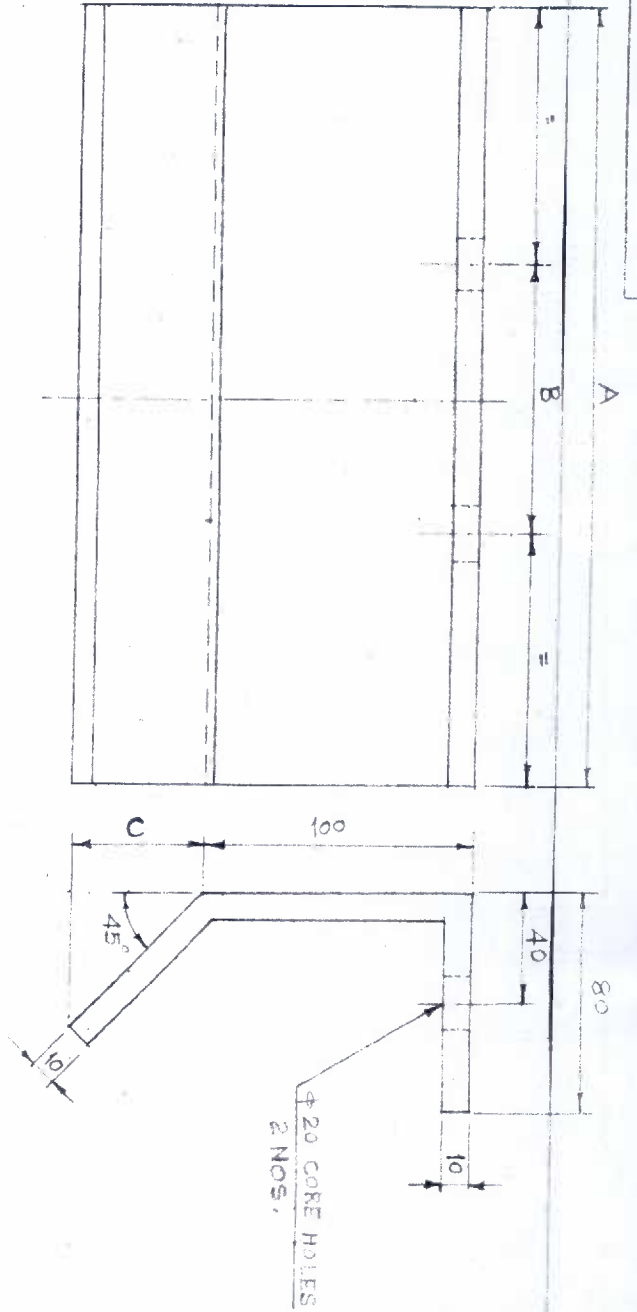

Inventory No. (12,56) Sign. & Date Ref. Drg. No.

NO. DESCRIPTION	INVENTORY NO.	A	B	C	QTY.	WT./KG.
1 CASTING	FF8121060540	390	200	49.50		6.50
2 CASTING	FF8121060559	290	100	49.50		4.84
5 CASTING	FF8121060427	390	200	28.25		5.72
6 CASTING	FF8121060435	290	100	28.25		4.62

MATERIAL : H.R. C.I.

C-3.1% C, 0.35% Si, 2% Mn, 0.8% P, 0.12% S, 0.15% Cu, 0.2% Ni

DATE 15/11/75
 CHECKED
 ALTERED
 MTL. CHANGED

TYPE OF PRODUCT OR NAME OF CUSTOMER / PROJECT



BHARAT HEAVY ELECTRICALS LTD.

UNIT: C.F.F.P., HARDWAR.

DEPT. F.E.	CODE	SCALE 1:2	WEIGHT (KG)	REF. TO ASSY. DRG.	ITEM NO.
------------	------	-----------	-------------	--------------------	----------

BOGIE CASTINGS (1/2 S&G) FOR VULCAN FURNACE.

Dimensions to be Controlled Within Limits as Shown
 Machining Tolerance + .25 mm Unless Otherwise Shown, Non Machining Tolerance ±

CARD CODE	SHEET NO.	NO. OF SHEETS
01-08-028	03	05

APPROVED	DATE
	15/11/75