



ISO  
9001:2000  
&14001:2004  
NAVARATNA  
COMPANY

**MATERIAL MANAGEMENT (PURCHASE)**  
**CENTRAL FOUNDRY FORGE PLANT, BHEL HARDWAR**  
**RANIPUR, HARIDWAR (INDIA) – 249403**  
Phone No.01334-281277/285635, FAX No. 01334-225892  
**e-mail :ranjank@bhelhwr.co.in, svn@bhelhwr.co.in**

**Sub: Tender Enquiry No: 4415P/930/2/0657V1**

Dear Sir,

We are pleased to invite offer as per enclosed specification with terms and conditions in sealed envelop for the under mentioned material.

Sl No	Tender No	Description of Material	Qty	Date & Time of Tender Opening
01	4415P/930/2/0657V1	INGOT MOULD	4 Nos	28-01-2013 at 2.00 PM (IST)

Kindly read terms and conditions carefully. Offer not submitted in accordance with the instructions is liable to be disqualified or ignored.

Please visit [www.bhel.com](http://www.bhel.com) or [www.bhelhwr.co.in](http://www.bhelhwr.co.in) for more details and tender documents.

Please also download Supplier Registration Form and submit same dully filled.

Thanking You,

Yours Faithfully,  
For & On behalf of CFFP BHEL Hardwar

(Ranjan Kumar)  
Sr.DGM (Purchase)

**Note: Corrigendum if any shall not be published, kindly visit web-site for any changes.**

Documents attached:

1. Enquiry.
2. Annexure - I of commercial terms.
3. Annexure B of General Terms and conditions of tender enquiry.
4. Annexure IV T&C regarding Indian agent of foreign suppliers.
5. Annexure V T & C of reverse auction.
6. Annexure D for e payment format.
7. Drawings.



निविदा सूचना  
**TENDER ENQUIRY**

भारत हेवी इलैक्ट्रिकल्स लिमिटेड  
**Bharat Heavy Electricals Ltd**  
सेन्ट्रल फाउन्ड्री फॉर्ज प्लांट- हरिद्वार - २४६४०३ (भारत)  
**Central Foundry Forge Plant, Haridwar-249403 (INDIA)**

AA-17001

Phone : (0091) 01334- 281639,281385,285336

Fax : 01334 225892 / 226458

TIN NO. 05001763485  
C S T NO. HR-5018287 Dt. 16-03-1995

निविदा सूचना सं. ENQUIRY NO.*	4415 P/ 930/2/0657V1	दिनांक Date	28-12-2012
-------------------------------	----------------------	-------------	------------

कृपया निम्नलिखित के लिए निविदा दें। PLEASE QUOTE FOR THE FOLLOWING :

M/S. ::

DUEDATE

28-01-2013

::

Vendor Code

09285

INDIA

SL	MATERIAL CODE ITEM DESCRIPTION	QUANTITY	UNIT	LOTNO	LOT DELIVERY QTY SCHEDULE
----	-----------------------------------	----------	------	-------	------------------------------

1	FF1978099142 DRG: 1700MM (02-206) REV: INGOT MOULD [1700MM(02-206)] .	1	NO	1	1 12/05/13
---	---	---	----	---	------------

2	FF1978099118 DRG: 1400MM(02-149) REV: INGOT MOULD [1400MM(02-149)]	3	NO	1	3 12/05/13
---	--	---	----	---	------------

\*\* IMPORTANT: This enquiry is 2 part tender. Techno-Commercial bid (Part-1) & Price Bids (Part-2) should be submitted in separate envelopes. These two envelopes should be submitted in a common sealed envelope. Techno-Commercial Bid shall contain detailed Technical Specification, Drawings Technical documents, Catalogues, taxes & duties, payment terms, delivery period, Validity of offer, Replica of Price Bid (Copy of price bid without price part) etc. The confirmation to the special terms & conditions must be submitted alongwith Techno-Commercial bid.

## Standard Instructions:

TEST CERTIFICATE REQUIRED.  
GUARANTEE CERTIFICATE REQUIRED.  
BASIC RATES, TAXES DUTIES SEPERATELY  
CENVATABL DUPLICATE COPY OF INVOICE.

## Special Instructions:

CASTING TO BE SUPPLIED IN MACHINED CONDITION DULY STRESS RELIEVED.  
VENDER TO QUOTE PRICES WITH THEIR PATTERNS.  
TIN(SN) SHALL BE 0.005% MAX. IN PLACE OF 0.05% MAX.  
ARSENIC (As) SHALL BE 0.005% MAX.  
LEAD(Pb) SHALL BE 0.0003%MAX.

- =====
- (A) VALIDITY OF OFFER SHOULD BE MIN90 DAYS FROM DATE OF OPENING.  
(B) OFFER MUST BE SUBMITTED STRICTELY IN LINE WITH SPECIFICATION,  
TERMS & CONDITIONS OF ENQUIRY ELSE OFFER MAY LIKELY BE IGNORED.  
(C) ALL TAXES/DUTIES/LEVIES ETC. MUST BE SPECIFIED SEPERATELY IN  
AMOUNT OR IN PERCENTAGE. INCOMPLETE OFFER SHALL NOT BE ACCEPTABLE.  
(D) PLEASE QUOTE ON F.O.R. DESTINATION (CFFP/BHEL), FREIGHT PRE PAID  
BASIS ONLY.  
(E) IN CASE VENDOR DO NOT ACCEPT CFFP,S PAYMENT TERMS AS PER ENQUIRY



निविदा सूचना  
**TENDER ENQUIRY**

भारत हेवी इलेक्ट्रिकल्स लिमिटेड  
**Bharat Heavy Electricals Ltd**  
सेन्ट्रल फाउन्ड्री फॉर्ज प्लांट- हरिद्वार - २४६४०३ (भारत)  
**Central Foundry Forge Plant, Haridwar-249403 (INDIA)**

18

Phone : (0091) 01334- 281639,281385,285336

Fax : 01334 225892 / 226458

TIN NO. 05001763485  
CST NO. HR-5018287 Dt. 16-03-1995

निविदा सूचना सं. ENQUIRY NO.*	4415 P/ 930/2/0657V1	दिनांक Date	28-12-2012
-------------------------------	----------------------	-------------	------------

कृपया निम्नलिखित के लिए निविदा दें। PLEASE QUOTE FOR THE FOLLOWING :

MATERIAL CODE	QUANTITY	UNIT	LOTNO
ITEM DESCRIPTION			

PROPER LOADING SHALL BE DONE.

(F) INSPECTION AT CFFP AS PER BASED ON TC/GC OF THE PARTY.

(G) DULY FILLED & SIGNED WITH COMPANY SEAL "ANNEXURE-1 TO BE SUBMITTED  
ALONGWITH OFFER.

(H) DRAWINGS ARE ENCLOSED.

General Instructions:

1. Please submit authorization letter (format enclosed) for facilitating e-payment/electronic transfer of funds
  2. 100% payment within 30 days after receipt & acceptance of material at CFFP BHEL, Hardwar through e-payment.
  3. CFFP/BHEL RESERVES THE RIGHT TO PRE-INSPECT THE MATERIAL AT VENDOR'S WORKS / GODOWN/ PREMISES BEFORE DESPATCH.
  4. ORIGINAL MANUFACTURER'S TEST CERTIFICATE IS REQUIRED ALONG WITH DESPATCH DOCUMENTS. IN CASE SUPPLIES ARE FROM TRADERS, IT SHALL BE THE RESPONSIBILITY OF THE TRADER TO PROVIDE ORIGINAL MANUFACTURER'S TEST CERTIFICATE WITH LINKAGE TO TRADER'S INVOICE STATING BATCH NO.
  5. CFFP/BHEL Reserves the right to procure from more than one vendor.
  6. Please quote prices in figures & words both. In case the prices quoted in words and figures are different, the values indicated in words will be considered for evaluation & establishing L1 status.
- \* The offers of the bidders who are on the banned list as also the offers of the bidders, who engage the services of the banned firms, shall be rejected. The list of banned firms is available on web site [www.bhel.com](http://www.bhel.com)

D S RAWAT

ENGINEER ( PUR. )

Commercial Terms

Item - Ingot Mould

Qty - 4 Nos

Confirmation/comments on the conditions given below are mandatory. Please confirm the following or else your offer is liable to be rejected.

	Description	Vendor Confirmation /Comment.
01	Material shall be supplied as per enquiry no <b>4415P/930/2/0657V1</b> in all respects without deviation.	
02	Guarantee / Test certificate required.	
03	Delivery shall be made on FOR Destination basis, destination being Stores/CFFP/BHEL Haridwar, Freight & Insurance charges to vendor's account.	
04	Payment Term: 100% within 30 days after receipt & acceptance (commissioning) of material at CFFP / BHEL, Haridwar through e-payment. Foreign Suppliers – Payment through USANCE L/C on 70 day from B/L date.	
05	Validity of offer: Minimum 90 days from tender opening date.	
06	Prices shall be firm till execution of Order.	
07	Provide name of contact person, mobile no. & email address.	
08	LATE DELIVERY PENALTY CLAUSE (LD) : Penalty for late delivery shall be applicable @ 0.5% per week and part thereof subject to a maximum of 10% for total P.O. value (Total material cost + packing and forwarding + freight) from the date of scheduled delivery of Purchase Order.	
09	Replica of price bid (without price part) required along with offer.	
10	For new vendors who are not registered with CFFP BHEL Haridwar, duly filled up "Supplier Registration Form" (available at www.bhel.com) along-with all the supporting documents has to be submitted along-with techno-commercial bid of offer. Please confirm that SRF is being submitted with your offer if applicable. However please note that if in any case duly filled up SRF along-with all the supporting documents is not received within 15 days of tender opening, your offer will liable to be ignored.	
11	Disputes: In event of any dispute arising out of contractual obligation, the order being finalized at Haridwar, India will be subject to Indian laws and falls under jurisdiction of the court of Law at Haridwar, India. The overseas supplier hereafter referred to as "Vendor" shall therefore abide by the verdict of court of Law at Haridwar, India.	
12	BHEL will prefer to deal directly with foreign vendor/ original manufacturer. In case, vendor engages any Indian agent or take service of any Indian agent, copy of agent agreement required along with offer in line with Annexure-IV attached.	
13	<b>Pre Qualification Criteria ( P Q C ):</b> <ul style="list-style-type: none"> <li>- Vendor should have supplied cast Iron Ingot mould in the weight range of 50 tons to 55 tons. (For 1700 MM).</li> <li>- Vendor should have supplied cast iron ingot mould in the weight range of 25 tons to 30 tons (For 1400 MM)</li> </ul>	
14	- In case any column is left blank, it shall be deemed to be accepted by vendor. - If any difference is found for any term and condition in the offer and this annexure "I", the terms quoted in this annexure 'I' shall be deemed as final and binding on vendor. - Evaluation shall be on the basis of delivered cost (i.e.) "total cost to BHEL".	

Date:

Signature with Seal of the Company.

GENERAL TERMS AND CONDITIONS OF TENDER ENQUIRY  
ANNEXURE-B

01 Submit the tender in two parts i.e.

**Part-I Techno-Commercial Bid**

**Part-II Price Bid**

Techo - Commercial (part one) Price Bid (part two) should be put in separate sealed envelopes. Both envelopes should be super scribed with **Tender Number, Date of opening & Technical / Commercial Bid and Price Bid** respectively along with name of firm.

Both the envelopes i.e. containing Techno-Commercial Bid and Price Bid should again be kept in one envelope super scribed again with Tender No. and Date of opening and the name of firm submitting the tender and send it to **AGM (MM), Purchase Department, CFFP/BHEL, Hardwar, Ranipur, Hardwar 249403, Uttarakhand, India before due date / tender opening date & time**. Normally tender opening time is 2.00 PM on due date or as mentioned in enquiry.

**Responsibility for submission of tender in time solely lies with vendor. Late offers received after specified time / Date shall not be considered.**

1. Part-I Envelopes super scribed with **Techno-Commercial Bid** must contain all information especially-
  - (a) Specification of the material offered should be strictly as per CFFP/BHEL specifications of enquired material in tender documents **Deviations if any must be indicated clearly in the offer. Rates to be quoted on For Destination Basis.**
  - (b) All commercial terms i.e. packing, forwarding Custom duty, Additional Duty, ST/STT/VAT/CST, Excise Duty/CVD. Bank charges, payment terms & insurance etc as applicable (**except price**) should be clearly mentioned in Techno-Commercial bid. Also mention present rate of applicable taxes & duties even if inclusive in rates along with the concessional forms required if any.
  - (c) Confirm to submit all required commercial documents (tax invoice centvatable duplicate copy of invoice, packing list, transit sale agreement etc.) & technical documents (TC/GC/QP etc).
  - (d) Registration Numbers of SSI, Central Excise, Sales tax, Income Tax, DGS & D.ECC etc.
  - (e) **Un-priced copy of Price Bid.**

Part-II Envelopes super scribed with Price Bid should contain priced copy of Price Bid. The price should be mentioned both in figures and words.

2. Authorized Signatory should authenticate all tender documents.
3. **Techno-commercial bid (Part-I)** will be opened on the due date at 2.00 PM in the presence of participating vendors or authorized representatives, who may wish to be present. Representative deputed to witness tender opening must produce an authority letter from the signatory of offer. After evaluation of technical bids & finalization of technical, commercial terms & conditions, price bid of only successful vendors will be opened. Priced bid opening date shall be intimated separately.
4. The material offered must conform to the required BHEL specifications and drawings as well as instructions and details made available.
5. For new vendors, Vendor Registration from duly filled must be submitted along with the offer which can be downloaded from our web site [www.bhel.com](http://www.bhel.com) or [www.bhelhwr.co.in](http://www.bhelhwr.co.in).
6. Original manufacturer's Test Certificate is required along with dispatch documents. In case supplies are from traders, it shall be the responsibility of the trader to provide original manufacture's test certificate with linkage to traders invoice stating batch no.
7. **Validity** of offers should be minimum 90 working days from the date of tender (Techno-Commercial Bid) opening.

8. **Delivery** in the promised period is the essence of contract. Confirm to supply according to delivery schedule mentioned.
9. **Payment terms:**  
For indigenous suppliers: 100% within 30 days after receipt & acceptance of material at CFFP / BHEL, Haridwar through e-payment.  
For foreign suppliers: Payment through USANCE LC on 70<sup>th</sup> day of bill of lading date. All bank charges shall be to vendor's account.  
  
\* In case vendor does not agree, proper loading shall be done. Also in that case, third party inspection shall have to be arranged by supplier from any of the five inspection agencies namely: LRS/ BVQI/ DNV/ TUV/ Alfred H Knight at their cost.
10. CFFP/BHEL, Hardwar reserves the right to accept or reject any or all tenders without assigning any reason thereof.
11. Tenders not submitted in the prescribed manner are likely to be ignored / rejected.
12. Agent/Agency Commissioning: Payment of any kind at any stage will not be made to agent on account of agent commission or otherwise by CFFP/BHEL, Hardwar.
13. CFFP/BHEL, Hardwar may opt for E-auction/Reverse auction for obtaining best prices for part or full tendered quantity. BHEL also reserve the right to negotiate price with L1 vendor after reverse auction.
14. Please do intimate the personal contact details like Name, Mobile Number, Email-id etc of authorized executive for correspondence.
15. **Penalty:** Orders placed against this enquiry will be subject to normal clauses for imposing penalty. Liquidated Damages, Risk purchases, cancellation, arbitration as per terms and conditions of Tender Enquiry and Purchase orders in case of delay in effecting supply and/ or other defaults.  
**Liquidated damage:** The delivery of the goods shall be made strictly as per time limit specified in delivery schedule, failure to supply within this period will make the supplier liable to an conditional penalty of 1/2 (half) percent of the price of the goods in arrears per week subject to a maximum of 10%.
16. **Inspection:** Final inspection of material shall be done after receipt of material at CFFP/BHEL, Hardwar. Acceptance of material shall be after final inspection and shall be binding. However, CFFP reserves the right to pre Inspect the material at supplier works. In case material is found defective during warranty period, the same will be returned for repair and/ or replacement. For this vendor has to bear all the charges such as Freight, to and fro insurance etc. Bank Guarantee for the equal amount to the cost of the item is to be furnished by vendor. In case the repair is done at CFFP/BHEL the amount on actual shall have to be reimbursed by the Vendor and or adjusted on actual from their bill.
17. **Currency of Payment:** Mention the currency in which payment has to be made. For evaluation of price bids, exchange rate (TT selling rate of SBI) as on scheduled date of tender opening (Part-1 bid in case of two part bid) shall be considered.
18. Traders should submit authorization letter from their principal alongwith offer.
19. Disputes: In event of any dispute arising out of contractual obligation, the order being finalized at Hardwar, India will be subject to Indian Laws and falls under jurisdiction of the court of Law at Haridwar, India. The overseas supplier hereafter referred to as "Vendor" shall therefore abide by the verdict of Court of Law at Hardwar, India.  
OR  
All disputes arising out of or in connection with the present contract, if any shall be finally settled under the rules of arbitration of International chamber of commerce by one or more arbitrator appointed in accordance with the said Rules in India.
20. BHEL reserves the right to place P.O. for part / full qty and on one or more than one sources.
21. Any Term & condition of the specific tender (if specified in tender & contradicts with above term) will supersede the above general terms & conditions.

### **Terms and conditions regarding Indian agent of foreign suppliers:**

01. BHEL shall deal directly with foreign vendors, wherever required, for procurement of goods. However, if the foreign principal desires to avail of the services of an Indian agent, then the foreign principal should ensure compliance to regulatory guidelines- which require mandatory submission of an Agency agreement.
02. It shall be incumbent on the Indian agent and the foreign principal to adhere to the relevant guidelines of Government of India, issued from time to time.
03. The agency agreement should specify the precise relationship between the foreign OEM/Foreign principal and their Indian agent and their mutual interest in the business. All services to be rendered by agent/associate, whether of general nature or in relation to the particular contract, must be clearly stated by the foreign supplier / Indian agent. Any payment, which the agent or associate receives in India or aboard from the OEM, whether as commission or as a general retainer fee should be brought on record in the agreement and be made explicit in order to ensure compliance to laws of the country.
04. Any agency commission to be paid by BHEL to the Indian agent shall be in Indian currency only.
05. Tax deduction at source is applicable to the agency commission paid to the Indian agent as per the prevailing rules.
06. In the absence of any agency agreement, BHEL shall not deal with any Indian agent (authorized representatives/ associate/consultant, or by whatever name called) and shall deal directly with the foreign principal only for all correspondence and business purposes.
07. The "Guidelines for Indian Agents of Foreign Suppliers" enclosed at annexure- 'A' shall apply in all such cases.
08. The supply and execution of the Purchase Order (including indigenous suppliers/service) shall be in the scope of the OEM/ Foreign principal. The OEM/ Foreign principal should submit their offer inclusive of all indigenous suppliers/services and evaluation will be based on 'total cost to BHEL'. In case OEM/ foreign principal recommends placement of order(s) towards indigenous portion of supplies/services on Indian Supplier (s)/ agent on their behalf, the credentials/capacity/capability of the Indian Supplier (s)/ agent to make the supplies/Services shall be checked by BHEL as per the extant guidelines of Supplier Evaluation, Approval and Review Procedure (SEARP), before opening of price bids. In this regards, details may be checked as per Annexure- 'B' (copy enclosed). It will be the responsibility of the OEM/ Foreign Principal to get acquainted with the evaluation requirements of Indian supplier/agent as per SEARP available on [www.bhel.com](http://www.bhel.com).

The responsibility for successful execution of the contract (including indigenous supplies/services) lies with the OEM/ foreign principal. All bank guarantees to this effect shall be in the scope of the OEM/Foreign principal.

**Guidelines for Indian Agents of Foreign Suppliers**

- 1.0 There shall be compulsory registration of agents for all Global (Open) Tender and Limited Tender. An agent who is not registered with BHEL shall apply for registration in the registration form in line with SEARP.
- 1.1 Registered agents will file an authenticated Photostat copy duly attested by a Notary Public/Original certificate of the Principal confirming the agency agreement and giving the status being enjoyed by the agent and the commission/ remuneration/ salary/ retainership being paid by the principal to the agent before the placement of order by BHEL.
- 1.2 Wherever the Indian representatives have communicated on behalf of their principals and the foreign parties have stated that they are not paying any commission to the Indian agents, and the Indian representative is working on the basis of salary or as retainer, a written declaration to this effect should be submitted by the party (i.e. Principal) before finalizing the order.
- 2.0 Disclosure of particulars of agents/ representatives in India, if any.**
- 2.1 Tenderers of Foreign nationality shall furnish the following details in their offers:
  - 2.1.1 The Bidder(s)/ Contractor(s) of foreign origin shall disclose the name and address of the agents/ representatives in India if any and the extent of authorization and authority given to commit the Principals. In case the agent/ representative be a foreign Company, it shall be confirmed whether it is existing Company and details of the same shall be furnished.
  - 2.1.2 The amount of commission/ remuneration included in the quoted price(s) for such agents/ representatives in India.
  - 2.1.3 Confirmation of the Tenderer that the commission/ remuneration, if any, payable to his agents/ representatives in India, may be paid by BHEL in Indian Rupees only.
- 2.2 Tenderers of Indian Nationality shall furnish the following details in their offers:
  - 2.2.1 The Bidder(s)/ Contractor(s) of Indian Nationality shall furnish the name and address of the foreign principals, if any, indicating their nationality as well as their status, i.e. whether manufacturer or agents of manufacturer holding the Letter of Authority of the Principal specifically authorizing the agent to make an offer in India in response to tender either directly or through the agents/ representatives.
  - 2.2.2 The amount of commission/ remuneration included in the price (s) quoted by the Tenderer for himself.
  - 2.2.3 Confirmation of the foreign principals of the Tenderer that the commission/ remuneration, if any, reserved for the Tenderer in the quoted price(s), may be paid by BHEL in India in equivalent Indian Rupees on satisfactory completion of the Project or supplies of Stores and Spares in case of operation items.
- 2.3 In either case, in the event of contract materializing, the terms of payment will provide for payment of the commission/ remuneration, if any payable to the agents/ representatives in India in Indian Rupees on expiry of 90 days after the discharge of the obligations under the contract.
- 2.4 Failure to furnish correct and detailed information as called for in paragraph 2.0 above will render the concerned tender liable to rejection or in the event of a contract materializing, the same liable to termination by BHEL. Besides this there would be a penalty of banning business dealings with BHEL or damage or payment of a named sum.

---X---

This format is applicable only to Indian Suppliers/ Agents supplying indigenous portion of Foreign Purchases.

\* In all other cases, extant guidelines of SEARP, 2010 are to be followed.

SEARP (SRF) Clause No	Detail
	<b>Name &amp; address of the firm</b>
<b>1.0</b>	<b>Products/ Systems / Services being considered for</b>
<b>2.0</b>	<b>General Information</b>
2.2	Name of Chief Executive
2.3	Details of authorized signatory
<b>3.0</b>	<b>Ownership Information</b>
3.1	Type of firm
3.2	Nature of Business <ul style="list-style-type: none"> <li>• <i>Attach <b>authorization letter</b> and <b>agency agreement</b> from Principal ( from whom capital equipment is procured)</i></li> <li>• <i>Attach copy of declaration from Foreign Principal for <b>total guarantee/ warranty of indigenous supplies</b></i></li> </ul>
3.3	Year of establishment
3.4	Year of commencement of business
<b>4.0</b>	<b>Registration particulars</b>
4.1	Permanent Account No.
4.2 / 4.3	Sales Tax / TIN no
4.6	Service tax no. (in case of E&C)
<b>5.0</b>	<b>Organisational strength</b>
<b>6.0</b>	<b>Other particulars</b>
6.1	If the company is already registered with other units
6.2	Directors/ Partners, if related to any BHEL Employee
6.9	If any Ex BHEL Personnel employed by the Company
6.12	Details of pending legal issues with BHEL
6.13	Bank Account information
<b>9.0</b>	<b>Financial information</b>
9.6	Sales/ Turnover details of last 3 years (or from the date of incorporation whichever is less )

---X---

**GENERAL TERMS AND CONDITIONS OF REVERSE AUCTIONING**

Against this enquiry for the subject item /system with detailed scope of supply as per enquiry specifications, BHEL may resort to “REVERSE AUCTION PROCEDURE” i.e., ON LINE BIDDING ON INTERNET.

1. For the proposed reverse auction, technically and commercially acceptable bidders only shall be eligible to participate.
2. BHEL will engage the services of a service provider who will provide all necessary training and assistance before commencement of on line bidding on internet.
3. BHEL will inform the vendor in writing in case of reverse auction, the details of Service Provider to enable them to contact & get trained.
4. Business rules like event date, time, start price, bid decrement, extensions etc. also will be communicated through service provider for compliance.
5. Vendors have to fax the Compliance form in the prescribed format (provided by Service provider) before start of Reverse auction. Without this, the vendor will not be eligible to participate in the event.
6. BHEL will provide the calculation sheet (e.g., EXCEL sheet) which will help to arrive at “Total Cost to CFFP/BHEL” basis which covers all parameters of specification and commercial terms for each of the vendor to enable them to fill-in the price and keep it ready for keying in during the Auction.
7. Reverse auction will be conducted on scheduled date & time.
8. At the end of Reverse Auction event, the lowest bidder value will be known on the network.
9. The lowest bidder has to Fax the duly signed Filled-in prescribed format as provided on case-to-case basis to BHEL through Service provider within 24 hours of Auction without fail.
10. Any variation between the on-line bid value and the signed document will be considered as sabotaging the tender process and will invite disqualification of vendor to conduct business with BHEL as per prevailing procedure.
11. In case BHEL decides not to go for Reverse Auction procedure for this tender enquiry, the Price bids and price impacts, if any, already submitted and available with BHEL shall be opened as per BHEL’s standard practice.

AUTHORISATION LETTER  
FOR E-PAYMENT/ELECTRONIC FUNDS TRANSFER (EFT/RTGS)  
PLEASE FILL UP THE FORM IN CAPITAL LETTERS ONLY

ANNEXURE-D  
Page 1 of 1

TYPE OF REQUEST (Tick One)	<input type="checkbox"/>	CREATE	<input type="checkbox"/>	CHANGE
<hr/>				
BHEL Vendor/ Supplier Code	<input type="text"/>			
Company's Name	<input type="text"/>			
Address	<input type="text"/>			
	<input type="text"/>			
City	<input type="text"/>			
Pincode	<input type="text"/>			
State	<input type="text"/>			
<hr/>				
Contact Person(S)	<input type="text"/>			
Telephone NO.	<input type="text"/>			
FAX. No.	<input type="text"/>			
e-mail id	<input type="text"/>			
<hr/>				
1. Bank Name	<input type="text"/>			
2. Bank Address	<input type="text"/>			
	<input type="text"/>			
3. Bank Telephone No.	<input type="text"/>			
4. Bank Account No.	<input type="text"/>			
5. Account Type.	<input type="text"/>			
6. Bank's Branch Code	<input type="text"/>			
7. Bank Swift Code	<input type="text"/>			
(aplicable to EFT only)				
8. Enclose blank cancelled cheque	<input type="checkbox"/>	<input type="checkbox"/>		

DECLARATION

1. I as representative/Owner of the above named company, hereby authorize BHEL CFFP, Ranipur, Haridwar to electronically make payments to the designated bank account. I hereby certify that the particulars given above are true, complete and correct.  
(2) If the transsation is delayed or not effected at all for reasons of incomplete or incorrect information, I would not hold BHEL/transfereing Bank responsible.
3. This authority remains in full force untill BHEL, CFFP, Ranipur, Haridwar receives & acknowledge written notification requesting a change or cancellation.
4. I have read the contents of the covering letter and agree to discharge the responsibilty expected of me as a participant under E-payment/EFT/RTGS.

Date:

Authorized Signatory  
Designation

Company Seal

Verification By Bank

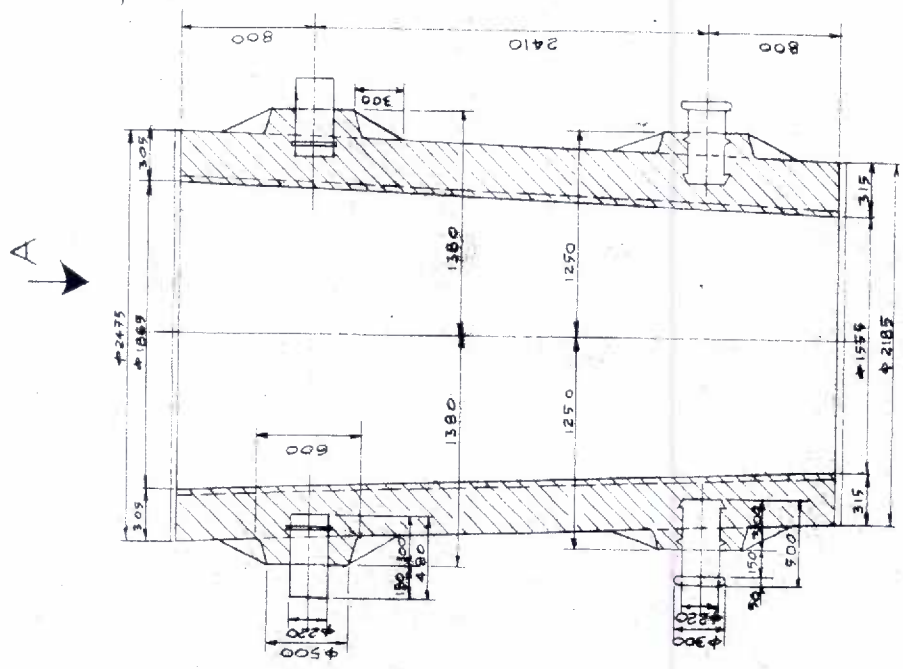

COMPOSITION OF MATERIAL  
SCALE: 1:20

S.No	CAST IRON WITH COMPOSITION	CONDITION OF DELIVERY
8	CHROMIUM	STRESS - RELIEVED
7	NICKLE	
6	TIN	
5	PHOSPHORUS	
4	SULPHUR	
3	MANAGANESE	
2	SILICON	
1	TOTAL CARBON	

Note: Composition requirement  
 AS per SPIL Technology  
 Ti2 = 0.005% Max  
 Arsenic = 0.005% Max  
 Lead = 0.0003% Max

22/03/12

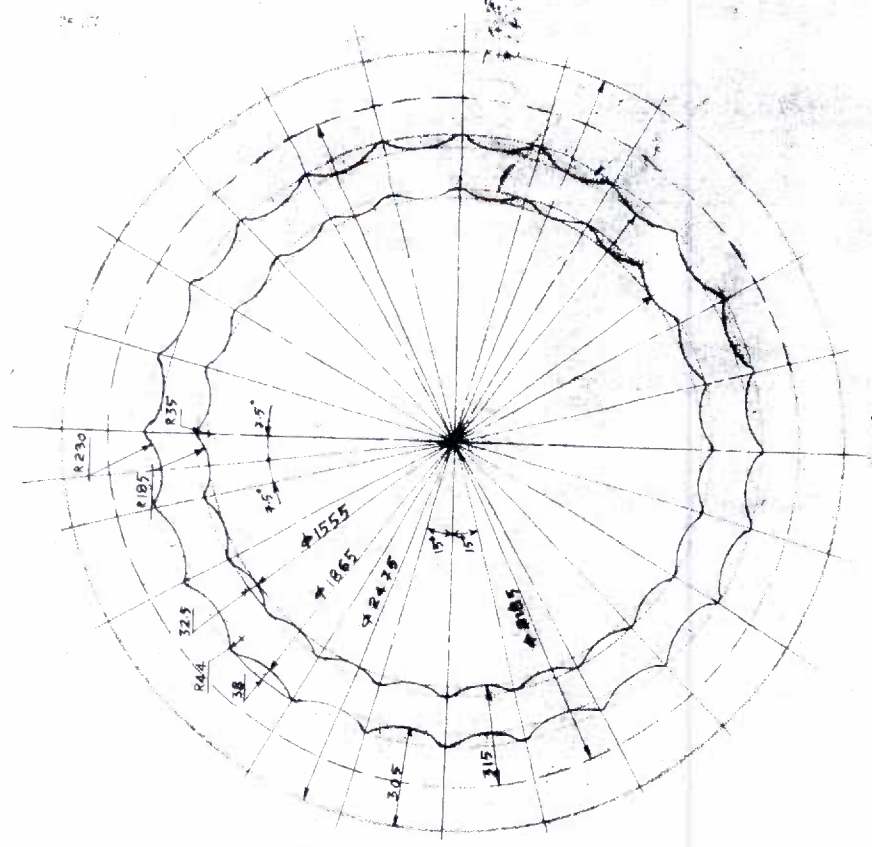

VIEW-A  
SCALE: 1:10

BRADY NEAR OPTICAL UNIT: CENTRAL PHOTOGRAPHY WORKS PVT. LTD.

DATE: 11/03/12

DR: MTK

DR: MTK

NO: 02-208

INGOT MOULD P1700

The information on this document is the property of BHARAT HEAVY ELECTRICALS LIMITED. It must not be used directly or indirectly in anyway detrimental to the interest of the company.

Inventory No. 23231010  
 Date: \_\_\_\_\_ Ref. Drg. No. \_\_\_\_\_

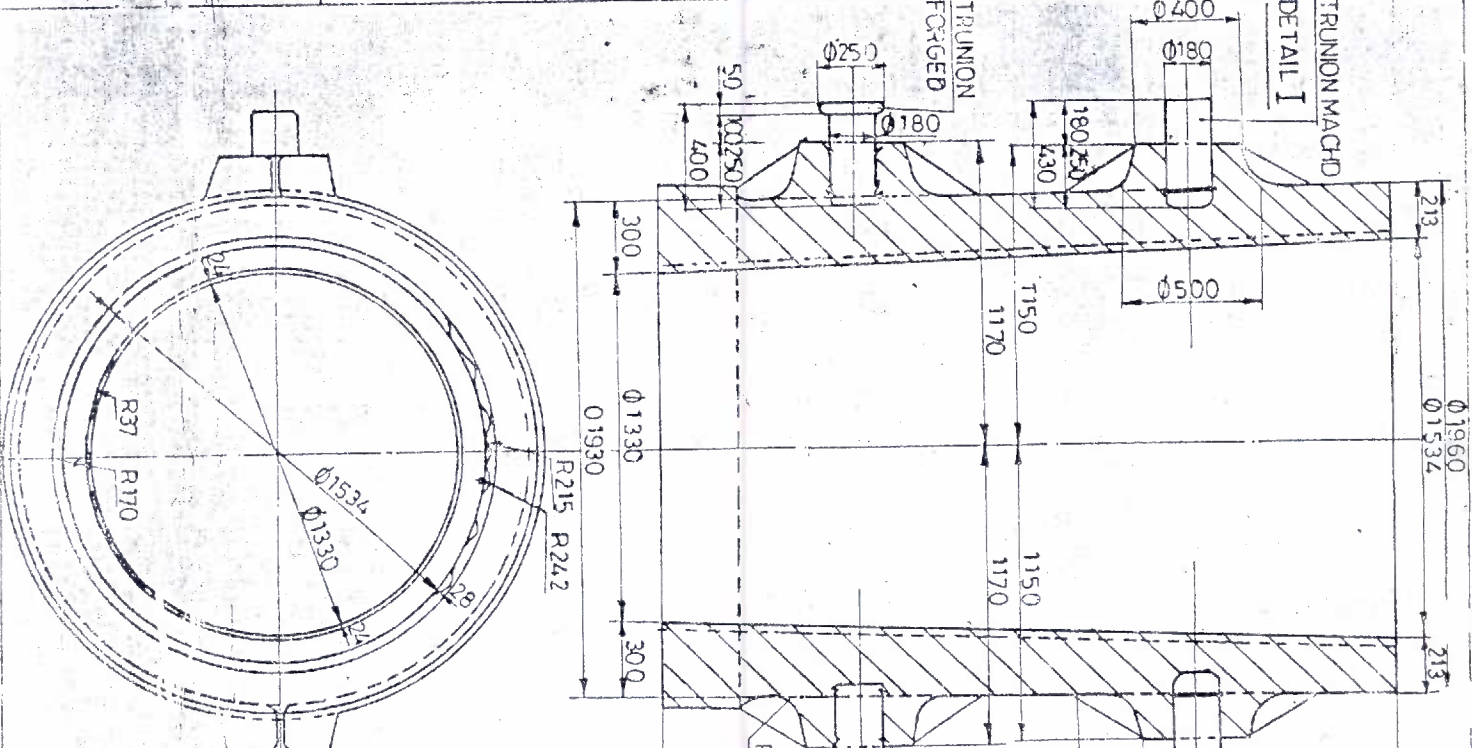

**DATA**

DIMENSIONAL UNIT	M.M.
WEIGHT UNIT	K.G.
DEPT. OF FOUNDRY	130/130
WT. OF BODY MM	1800/2500
WT. OF INGOT TONNE	2350/3100
RATIO H/D	1156/174
WT. OF SOLUTION	1-20
WT. OF HOT TONNE	3390/600
TOTAL WT. TONNE	2870/3870
TOTAL HT. MM	2750

DEPT.	SCALE	WEIGHT (KG)	REF. TO ASST. DRG.	ITEM NO.
1400 <sup>24</sup> R	1:20, 1:10	2700	23231010	
INGOT MOULD				
<b>BHARAT HEAVY ELECTRICALS LTD.</b> UNIT: C.F.F.P. HARDWARE.				
Dimensions to be Constant ± within limits as shown Machining Tolerance + .25 mm Unless Otherwise Shown, Non Machining Tolerance ±				
CARD CODE				
02-149				
SHEET NO.		NO. OF SHEETS		
01		7		

SL.	MATERIAL	COMPOSITION OF MATERIAL	REF/CL/BHEL/53	C.I. WITH COMPOSITIONS.
1.	TOTAL CARBON	3.6 TO 4.0%		
2.	SILICON	1.4 TO 2.0%		
3.	MANGANESE	0.4 TO 0.5%		
4.	SULPHUR	< .050%		
5.	PHOSPHORUS	< .120%		
6.	TIN	< .050%		
7.	NICKLE	< .050%		
8.	CHROMIUM	< .050%		

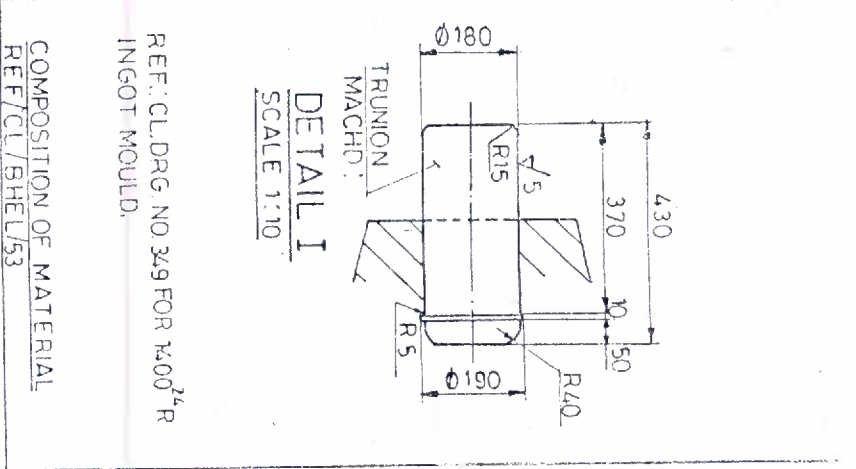
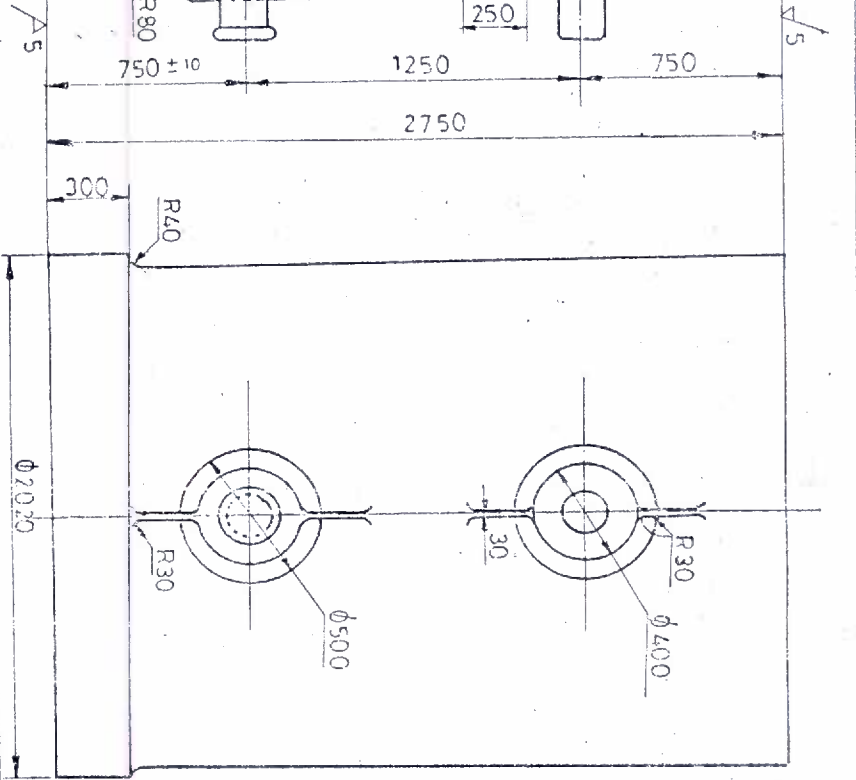

REF: CL DRG. NO 349 FOR 1400<sup>24</sup>R  
 INGOT MOULD.

SCALE 1:10