

Annexure – I

HP Inner Casing

- Weight of R/M HP Inner Casing (half):- 16000kg
- Length: - 3500mm
- Diameter: -1960mm (max.)
- Material grade: - HW19683 (**GX12CRMOVNBN9-1**)

Groove Details-

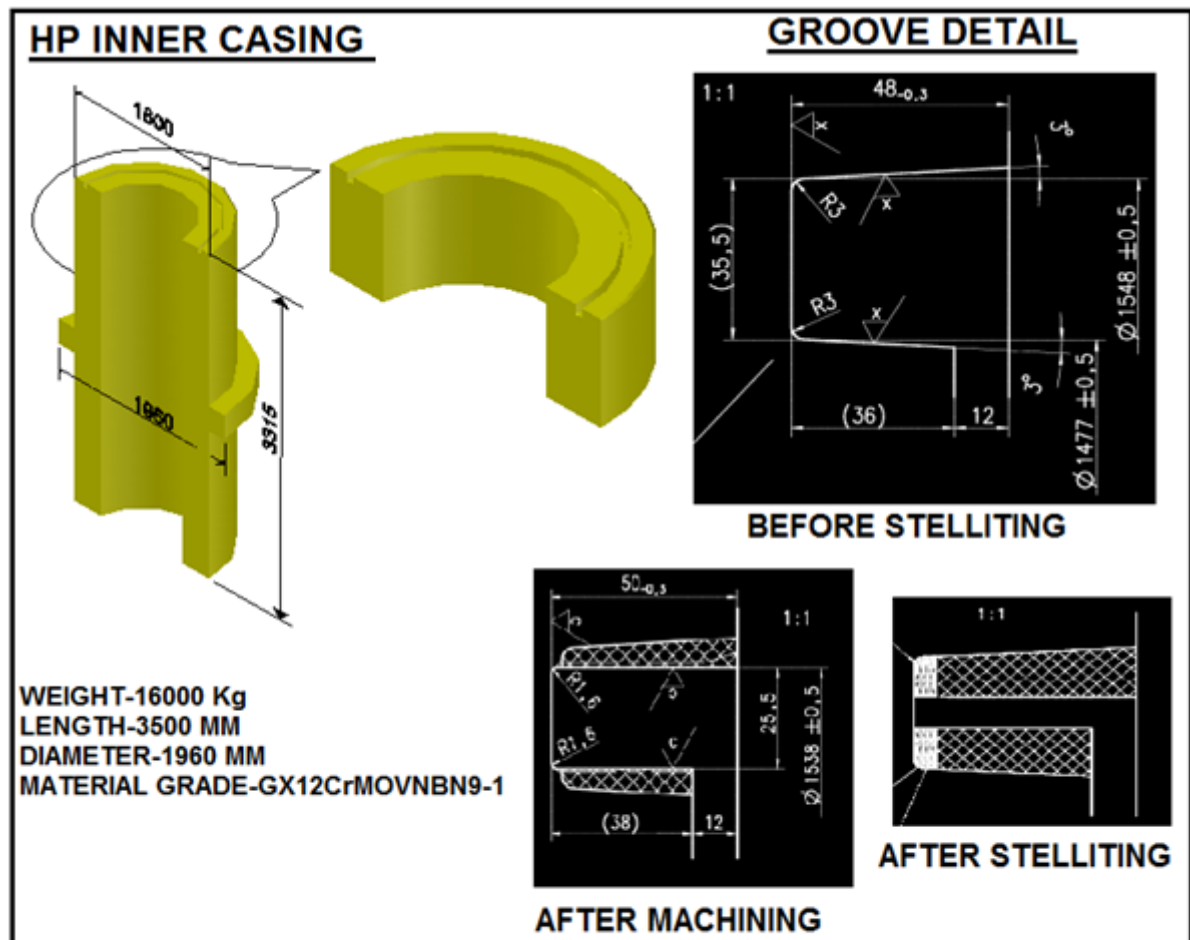

Annexure – II

Threaded Ring

- Weight of R/M Threaded Ring-40kg
- Diameter-480mm
- Height- 70mm
- Material grade- HW18812 (**X10CRMOVNB9-1**)

Groove details-

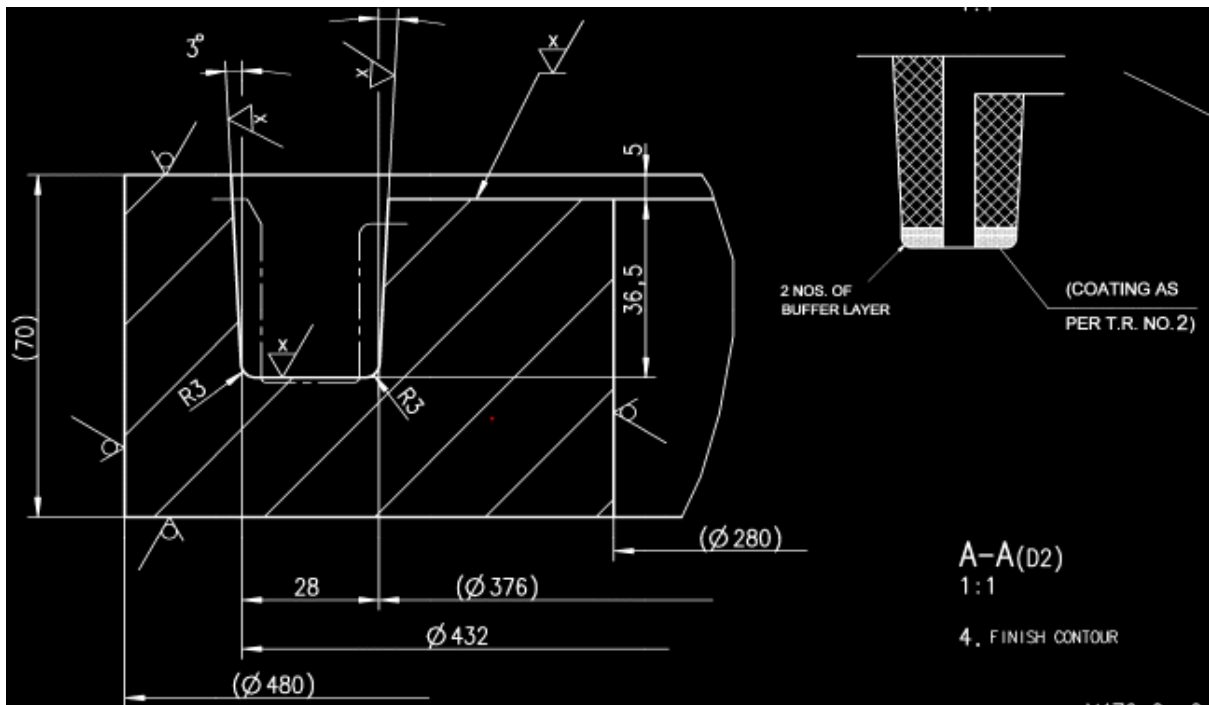
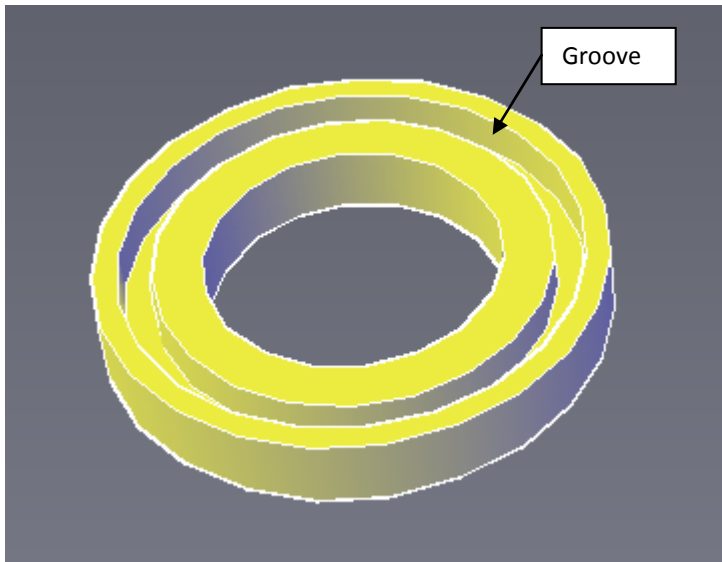

Annexure – III

Conical Half Ring

- Weight of two conical half ring after joining back to back- 1025kg
- Outer diameter-4782mm
- Material grade- AA10119 (IS:2062)

Groove details-

