

RD DG 4 35 0517 2510

FIRST ANGLE PROJECTION

(ALL DIMENSIONS ARE IN mm)

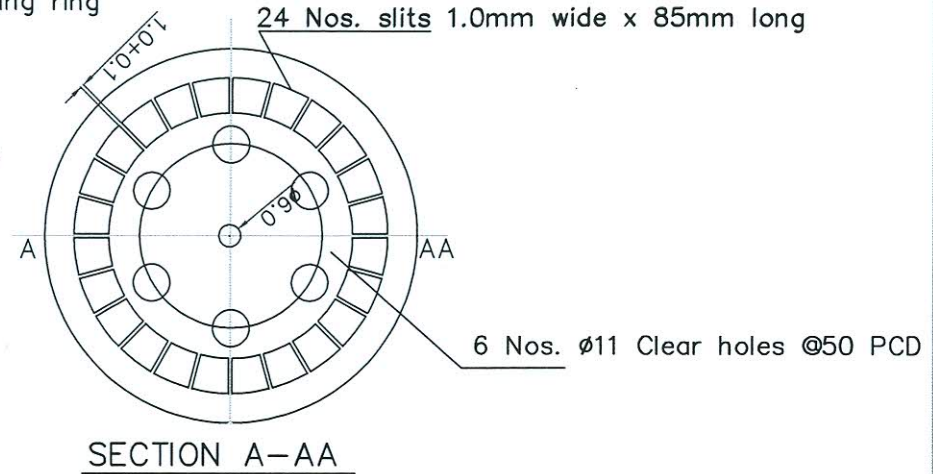
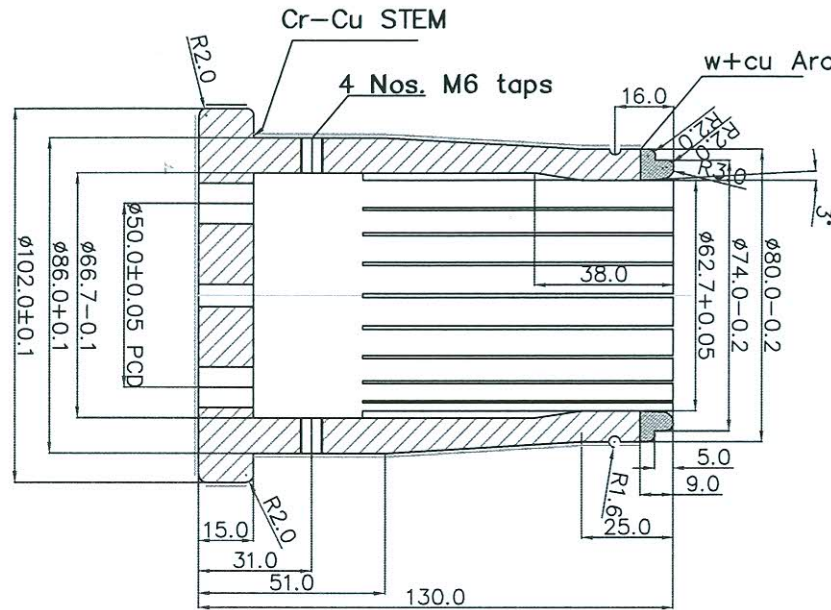

THE INFORMATION ON THIS DOCUMENT IS THE PROPERTY OF BHARAT HEAVY ELECTRICALS LIMITED. IT MUST NOT BE USED DIRECTLY OR INDIRECTLY IN ANY WAY DETRIMENTAL TO THE INTEREST OF THE COMPANY.

INVENTORY NO. SER. AND DATE REF. DRG. NO.

NOTE:

- SURFACE SHALL BE FINISHED TO RA0.8
- ALL SHARP EDGES SHALL BE FINISHED TO 0.4x45°
- COMPONENT SHALL BE SILVER PLATED TO 10-12 MICRON THK.
- COMPONENT SHALL BE SUPPLIED AS PER ENCLOSED SPECIFICATIONS.

| | | | |
|-------------|---------|----------|----------|
| W+Cu, Cu+Cr | | 01 | |
| VAR. NO. | REMARKS | VAR. NO. | ITEM NO. |
| | | | |

| | | | |
|----------------------|--------------------------|----------------------|---------------|
| TYPE OF PRODUCT | | GSM 245 | |
| NAME OF CUSTOMER | | GSM 245 | |
| | DRN | NAME | DATE |
| | CHK | BSM | 08.02.14 |
| | APPD | MMRAO | 08.02.14 |
| DEPT. | GRADE OF TOL. DIM. C/M/F | SCALE | WEIGHT(KG) |
| | | 01 NTS | |
| TITLE | CARD CODE | REF. TO | ITEM NO. |
| DS SWITCHING CONTACT | | RD DG 4 35 0517 2500 | 1 |
| | | DRAWING NO. | REV. |
| | | RD DG 4 35 0517 2510 | |
| | | SHEET NO. | NO. OF SHEETS |
| | | | |

| | | | | | |
|------|------|-----------------|------|------|-----------------|
| REV. | DATE | ALTERED CHECKED | REV. | DATE | ALTERED CHECKED |
| | | | | | |
| ZONE | | 01 | ZONE | | |

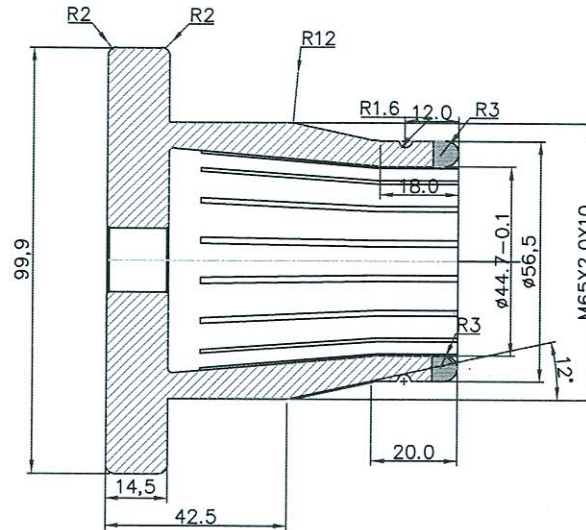
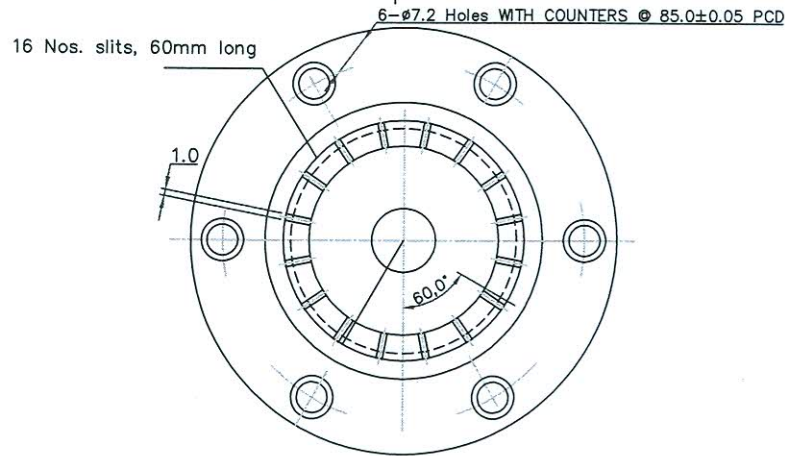
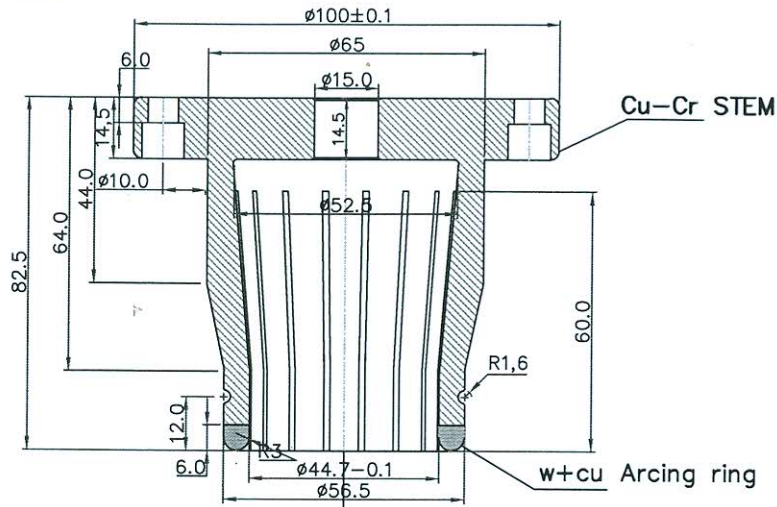

| W+CuCr | | W+CuCr | | W+CuCr | | | | | | | | |
|--------|------------|---------|----------|-------------|------|-------------|--------|-----------|---|------|----------|------|
| VAR.00 | REMARKS | VAR NO. | ITEM NO. | DESCRIPTION | STD. | DRAWING NO. | IT NO. | MATL CODE | A | UNIT | UNIT WT. | ZONE |
| VAR | MATL SPECN | QTY. | GS | ZONE | | | | | | | | |

SURFACE SHALL BE FINISHED TO RA0.8
 ALL SHARP EDGES SHALL BE FINISHED TO 0.4x45°
 COMPONENT SHALL BE SILVER PLATED TO 10-12 MICRON THK.
 COMPONENT SHALL BE SUPPLIED AS PER ENCLOSED SPECIFICATIONS.

FINAL ON 24/04/14

| | | | | | |
|-----------------|----------------------|------------------|------------|----------------------|----------|
| TYPE OF PRODUCT | | NAME OF CUSTOMER | | GSM245 | |
| DRN | NAME | SIGN. | DATE | NO. OF | |
| CKD | NSK | AK | 24/04/14 | VAR. | |
| APPD | MM RAO | MRS | 24/04/14 | | |
| DEPT. | GRADE OF | SCALE | WEIGHT(KG) | REF. TO | ITEM NO. |
| CODE | TOL. DIM. | C/M/F | | RD DG 4 35 0517 2300 | NO. OF |
| TITLE | ES SWITCHING CONTACT | | CARD CODE | DRAWING NO. | REV. |
| | | | | RD DG 4 35 0517 2310 | |
| | SHEET NO. | NO. OF SHEETS | | | |

| REV. | DATE | ALTERED | REV. | DATE | ALTERED |
|------|------|---------|------|------|---------|
| ZONE | | CHECKED | ZONE | | CHECKED |
| | | | | | |

THE INFORMATION ON THIS DOCUMENT IS THE PROPERTY OF BHARAT HEAVY ELECTRICALS LIMITED. IT MUST NOT BE USED DIRECTLY OR INDIRECTLY IN ANY WAY DETRIMENTAL TO THE INTEREST OF THE COMPANY.

REF. DRG. NO.

SIGN. AND DATE

INVENTORY NO.