



ISO 9001-2000, ISO 14001 and
OHSAS 18001 certified company

Sub-Contract and Purchase
Deptt.

Bharat Heavy Electricals Limited

(A Govt. of India Undertaking)

Power Sector – Northern Region,

Plot No. 25, Sector - 16A, Distt. Gautam Budh Nagar

NOIDA – 201301 (INDIA)

Phone: 91-120-2416548/2416262 Fax 91-120-2416528

Email: rahuldeb@bhelsnr.co.in/ susmitabasu@bhelsnr.co.in

TENDER ENQUIRY NO: BHEL/PSNR/SCP/RD/E- 2505

DATE: 27.11.2013

TENDER ENQUIRY

BHEL Power Sector, Northern Region invites sealed quotation from **manufacturers only** in **two part bid system** for the following item required at **BHEL –Lalitpur site** as follow:

Enquiry No.	DESCRIPTION	LAST DATE OF TENDER SUBMISSION & OPENING	DELIVERY SCHEDULE
BHEL/PSNR/SCP/RD/ E-2505	OFFLINE 3 STAGE OIL FILTRATION TROLLEY.	20.12.2013 AT 1530 HRS.	Within 12 WEEKS from the date of PO.

DESTINATION FOR SUPPLY IS AS FOLLOWS:

- (i) BHEL Site Office, Lalitpur Super Thermal Power Project, Village Mirchwara, P.O. Buragaon, Tehsil Mahroni, Distt. Lalitpur (U.P.) (Qty. = 1 Nos.).

QUALIFYING REQUIREMENTS / PAST EXPERIENCE:-

OFFER FROM MANUFACTURERS (OEM) WILL BE CONSIDERED AND OEM SHOULD FURNISH NECESSARY SUPPORTING DOCUMENTS AS UNDER:

1. ATLEAST ONE PO COPY IN LAST 3 YEARS, FOR THE SUPPLY OF OFFLINE 3-STAGE FILTRATION TROLLEY TO PURIFY OIL TO NAS 5 QUALITY, FROM DATE THE OF BID SUBMISSION ALONG WITH SUPPORTING DISPATCH DOCUMENT.
2. COMPANY REGISTRATION CERTIFICATE AS A MANUFACTURER.

NOTES:-

The Tender Document comprise of following:

- a. ANNEXURE- 1 (TECHNICAL SPECIFICATIONS)
- b. ANNEXURE-2 (IMPORTANT NOTES)
- c. ANNEXURE-3 (SPECIAL TERMS & CONDITIONS)
- d. ANNEXURE-4 (GENERAL TERMS & CONDITIONS)
- e. ANNEXURE-5 (UNPRICE FORMAT)
- f. ANNEXURE – 6 (RATE SCHEDULE)
- g. ANNEXURE – 7 (CERTIFICATE FOR NO DEVIATION)
- h. ANNEXURE – 8 (REVERSE AUCTION FORMAT AND TERMS & CONDITIONS)
- i. ANNEXURE – 9 (PBG FORMAT)
- j. ANNEXURE – 10 (FORMAT FOR E-PAYMENT DETAILS)

ANNEXURE-“1”TECHNICAL SPECIFICATIONS OF THREE STAGE FILTRATION TROLLEY

Scope: Design, manufacture, supply, installation & commissioning of “ Off line three stage filtration trolley” (Refer the attached scheme) to purify oil to NAS 5 quality.

Sl. No.	Description
1.	<p><u>APPLICATION OF THREE STAGE FILTRATION TROLLEY :</u></p> <p>Filtration of various fluids used in power plant applications namely:</p> <ul style="list-style-type: none"> • Hydraulic oil (Control Fluid) in control hydraulics tank • Lubrication oil in Turbine MOT, • Hydraulic oil in Boiler Feed Pump Oil Circuit Tank <p><u>Other oils in PA Fan, FD Fan, ID Fan, Fluid Coupling lub. Systems</u></p>
2.	<p><u>FLUID COMPATABILITY:</u> Fire Resistant Fluids – Triaryl phosphate ester marked ISO - L - HFDR (as per ISO 6743 / 4)</p> <p>Mineral Oils VG 32, 46, 68 & others.</p> <p>Lubricating oil VG 46 for turbine bearings.</p>
3.	<p>TROLLEY CONSISTS OF:</p>
3.1	<p><u>PUMPING STATION:</u></p> <p>PARAMETERS - Flow 150 lpm @ rated speed & relief valve pressure of 7 bar.</p> <p>COMPONENTS-</p> <p>a) <u>Pump:</u> Reputed make Gear Pump. Foot mounted type, End connections flange type. External relief valve. Connection with motor with flexible coupling.</p> <p>b) <u>Electric motor:</u> Of rating suitable to Pump above quantity and pressure, Reputed Brand / Make.</p> <p>TEFC Flange mounted, 4 poles, 1440 RPM, 3 phase, 415 Volts, 50 Hz.</p> <p>c) <u>Starter:</u> Direct Online Starter - Reputed Brand / Make.</p> <p>d) <u>MCB & ELCB</u> of Reputed Brand / Make.</p> <p>e) <u>ELECTRIC CABLE 4 core cable of 5 meters length</u> of Reputed Brand / Make.</p>
3.2	<p><u>FILTRATION STATION:</u></p> <p>This consists of Three (3) foot mounted filters mounted in series & interconnected by suitable size piping.</p> <p>a. <u>First Stage filter:</u> Reputed make, with 25 Microns Glass Fibre Element, Simplex type, foot mounted, filter element 01NR.1000.25VG.10.B.P.- Element design star shaped absolute filter media with Beta ratio more than 200, Collapse</p>

	<p>pressure 10 bar, Disposable type.</p> <p>b. Second Stage filter: Reputed make, with 10 Microns glass fibre element, simplex type foot mounted filter, with filter element 01NR.1000.10VG.10.B.P.- Element design star shaped absolute filter media with Beta ratio more than 200, Collapse pressure 10 bar, Disposable type.</p> <p>c. Third Stage filter: Reputed make, with 1 Microns glass fibre element, simplex type foot mounted filter, with filter element 01NR.1000.01VG.10.B.P.- Element design star shaped absolute filter media with Beta ratio more than 200, Collapse pressure 10 bar, Disposable type.</p> <p>d. Interconnected Piping: All are with 2" SAE flange inlet & outlet connections and connected with each other by 2" MS pipes and suitable hardware of reputed brand. ¼" size Minimes connections for oil sampling connected at suitable locations (Before & After Filters).</p> <p>e. Suction & Delivery Hoses: Viton Hose (Suitable for Control Fluid & Turbine Oil) preferably wire braided of 2" dia. size with 10 meters length each for suction & discharge and of reputed brand. It should withstand the temp. <u>up to 60 °C & pressure up 10 Kg / cm².</u></p>
<p>3.3</p>	<p><u>STRAINER:</u> Y- type strainer of size 2", screwed end of reputed brand of 150 Microns incorporated in the suction line of the pump (with one spare element).</p>
<p>3.4</p>	<p><u>ISOLATING VALVES:</u> Ball valves of reputed make, Size 2 "flange end, for suction and delivery of the filtration unit will be installed. These will be needed to isolate the filtration unit for element replacement / any maintenance.</p>
<p>3.5</p>	<p><u>SKID FABRICATION AND ASSEMBLY:</u> To avoid system-generated impurities, the piping will be done from carbon steel employing the TIG welding process. O-rings / Teflon seals will be used to ensure flange-to-flange tightness. The entire filtration system will be assembled on a fabricated SKID with an oil catcher tray. Above is to be mounted on 3 nos. of 6" caster wheels with locking arrangements. Suitable size handle with sturdy shackle will be provided.</p>
<p>3.6</p>	<p><u>SAMPLING BOTTLES:</u> <u>25 Nos. of sterilized plastic bottles of 200 ml capacity will be provided.</u></p>
<p>3.7</p>	<p><u>PRESSURE GAUGE:</u> <u>Glycerin filled pressure gauge with 0 to 10 bar rating along with minimes hose connection will be provided to measure the pressure drop across the filters.</u></p>
<p>3.8</p>	<p><u>OPERATION & MAINTENANCE MANUAL :</u> O & M Manual will be provided along with the filtration trolley.</p>

4	<p><u>SUPPLY, INSTALLATION & COMMISSIONING AT BHEL SITES:</u></p> <p>The offer should be inclusive of supervision for initial installation and commissioning at BHEL sites to the full satisfaction of BHEL Engineer. Demonstration and training will be conducted at BHEL site in presence of BHEL's Engineer and Vendor's representative and inspection will be done at vendor's works. Vendor to prove oil purification level to NAS 5 quality during demonstration.</p>
5	<p><u>RECOMMENDED FILTER ELEMENTS:</u></p> <p>i) Filter element for Filter 1 01.NR 1000.25VG.10.B.P.- (25 micron Glass fiber element)</p> <p>ii) Filter element for Filter 2 01.NR 1000.10VG.10.B.P.- (10 micron Glass fiber element)</p> <p>iii) Filter element for Filter 3 01.NR 1000.1VG.10.B.P.- (1 micron Glass fiber element)</p>
6	<p><u>FOLLOWING FEATURES SHOULD BE INCLUDED:</u></p> <p>6.1 The offer should be inclusive of supervision for initial installation, commissioning and demonstration (Total commissioning will be completed within 6 months of supply of instrument).</p>
	<p>6.2 SPARE REQUIREMENTS:</p> <ol style="list-style-type: none"> 1. The offer should be inclusive of at least <u>two sets of spare filters of each type</u>, as mentioned in SL. NO. 5 above, in addition to the one set of filters which will remain in assembled condition. 2. The offer should be inclusive of Suction and delivery hoses (Viton suitable for use of mineral oil, phosphate ester & lube oil at temperature up to 80 Deg. C) should be at least of 10 meters length each and in addition to this clamps on both sides for both suction and discharge should be supplied as spare quantity for at least 10 sets. Normally these are consumable items.(ONE SET INCLUDES SUCTION HOSE, DELIVERY HOSE AND CLAMPS FOR BOTH HOSES)
7	<p><u>Vendor shall submit their 'Quality Plan' for approval of BHEL with the technical bid.</u></p>

TENTATIVE SCHEMATIC DIAGRAM OF FILTRATION UNIT

3 STAGE FILTRATION

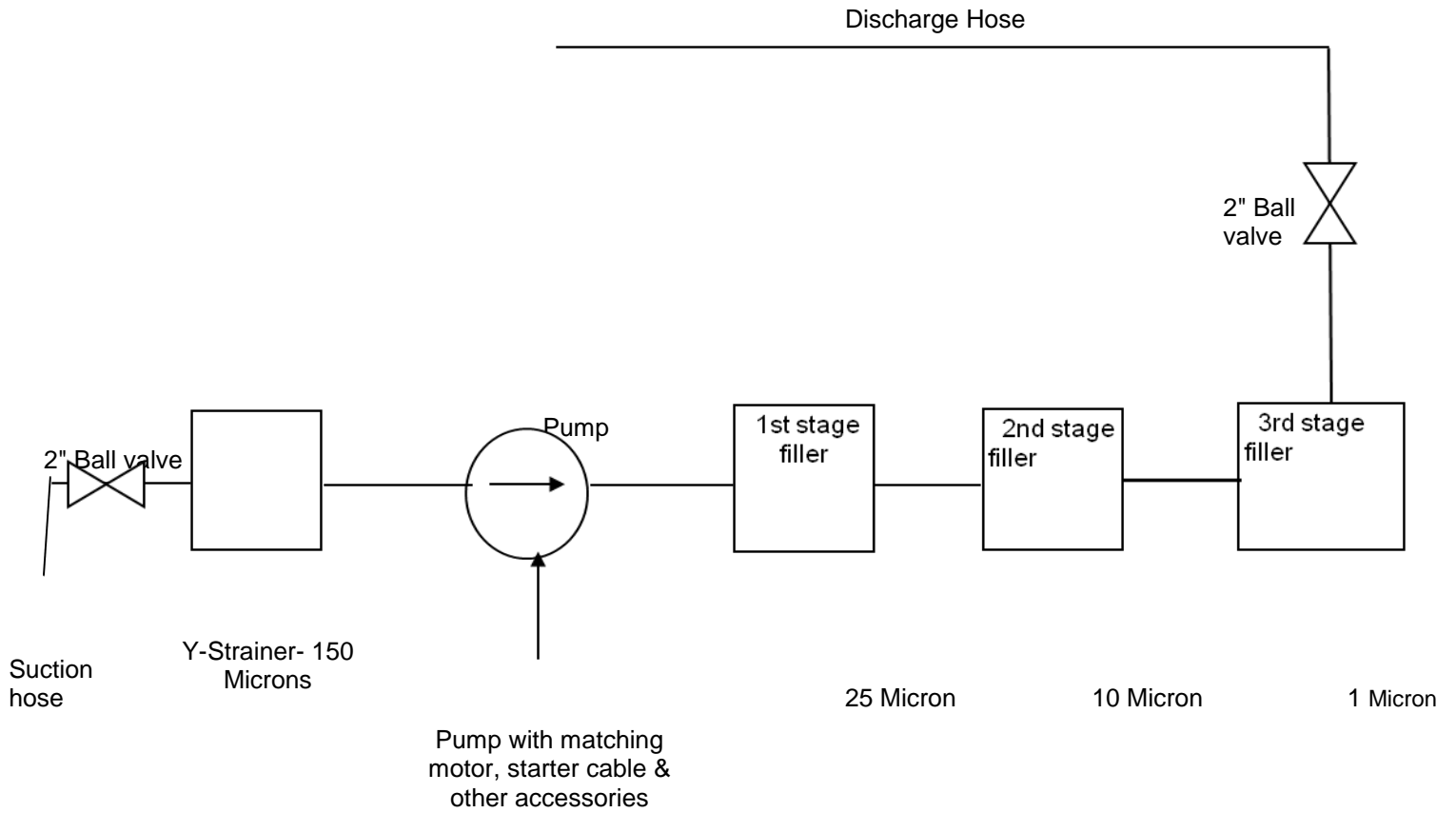

ANNEXURE-"2"

IMPORTANT NOTES

1. Bidders not offering the material as per specification described in Annexure – 1 are liable to be rejected.
2. All corrigenda, addenda, amendments and clarifications to this Tender **will be hosted in the web page and not in the newspaper**. Bidders shall keep themselves updated with all such amendments.
3. BHEL reserves the right to split, accepts or rejects any or all tenders without assigning any reason what so ever.
4. BHEL takes no responsibility for any delay/loss of documents or correspondences sent by courier/post.
5. Sealed tenders in two part bid system i.e. Part-I – Techno-Commercial bid and Part-II - Price bid are invited for supply, of "**OFFLINE 3 STAGE OIL FILTRATION TROLLEY.**" as per detailed specifications in Annexure-1, so as to reach us before the date of opening. The tenders (Part I only) will be opened at **15.30 PM (IST) on 20.12.2013**

6. Tender should not be addressed to any Individual's name but only by designation to:

**ENGINEER/ PURCHASE
BHARAT HEAVY ELECTRICALS LIMITED
Power Sector-Northern Region,
HRDI & ESI Complex, Plot no.25, Sector 16 A,
NOIDA –201301 (INDIA)**

7. TENDERS TO BE SUBMITTED IN TWO PARTS:

Part: I: Techno-commercial bid containing technical details along with commercial offer containing the following;

- (i) Covering letter/Offer forwarding letter of Tenderer.
- (ii) Supporting documents against Qualifying Requirements (QR) and vendor confirmation regarding technical specification.
- (iii) Duly filled-in 'No Deviation Certificate' as per Annexure -7.

Note:

- a. In case of any deviation, the same should be submitted separately for technical & commercial parts, indicating respective clauses of tender against which deviation is taken by bidder. It shall be specifically noted that deviation recorded elsewhere shall not be entertained.
 - b. BHEL reserves the right to accept/reject the deviations without assigning any reasons, and BHEL decision is final and binding. In case of unacceptable deviations, BHEL reserves the right to reject the tender.
- (iv) **Acceptance to commercial terms and conditions by submitting duly signed and stamped all pages of Tender document as a proof of acceptance.**
 - (v) All Amendments/Correspondences/Corrigenda/Clarifications/Changes/ Errata etc. pertinent to this tender.
 - (vi) Bidders shall submit their offer in INR only, the same to be indicated in their offer (Part-I).
 - (vii) Commercial: This part shall include / indicate the following:
 - (a) **Station of dispatch**
 - (b) **Taxes & duties applicable.**
 - (c) **Delivery Schedule**

- (viii) Copy of "Un-Priced Format as per Annexure - 5" i.e., without the price details to be enclosed with clearly mentioning that whether **QUOTED or NOT APPLICABLE**. (No hidden charges shall be accepted).
- (ix) Any other details preferred by bidder with proper indexing.

PART: II: PRICE BID AS PER ANNEXURE – 6, DULY FILLED, SIGNED AND STAMPED. IT SHOULD INCLUDE FOLLOWING:

- (i) Offered price (as per Rate Schedule format enclosed).
- (ii) The bidders should fully understand scope of supply and their responsibilities under the tender specifications before quoting. The bidders are required to quote only in Indian Currency for the rates as per rate schedule, in part-II price bid. Conditional price bid or price bid with any deviation are liable to be rejected. No cutting / erasing /overwriting shall be done in the price bid.

Note: Bidder may ensure to sign each page of the tender document / their offer while submitting techno - commercial offer/ price-bid.

8. Following should be super scribed on the envelopes of the two parts of the Bid.

Part I: Techno-Commercial Bid:-

Tender for: _____
Tender No. _____ Due on: _____

Part II: PRICE BID:

Tender for: _____
Tender No. _____

9. BOTH PART-I & PART-II SHOULD BE INDIVIDUALLY SEALED & SUPERSCRIBED AS INDICATED ABOVE & SHALL BE ENCLOSED IN ONE MAIN ENVELOPE DULY SEALED & SUPERSRIBED AS:

Tender for: _____
Tender No. _____ Due on: _____

Containing Part I and Part II of the offer

The tenders should be sent sufficiently in advance so as to reach before the due date and time. BHEL shall not be responsible in case of delay in receipt of tenders.

10. LANGUAGE & CORRECTIONS

- a) The Tenderer shall quote the rates in Hindi/English language and international numerals only. The rates shall be entered in figures as well as in words. For the purpose of tender, the metric system of units shall be used.
- b) All entries in the tender shall either be typed or written legibly in ink. Erasure and over-writings are not permitted and may render such tenders liable for rejection.
- c) Tenderer's offer, remarks and deviations, shall be with reference to sections and clause numbers given in the tender documents.
- d) All cancellations and insertions shall be duly attested by the tenderer.
- e) All columns for price format shall be filled. If not applicable, please write "NA"

11. TENDER EVALUATION

The Purchaser will examine the bids to determine whether they are complete, whether any computational errors have been made, whether required sureties have been furnished, whether the documents have been properly signed and whether the bids are generally in order.

12. PRICE DISCREPANCY

- a) Totals/Gross Total of Prices should be indicated both in words as well as in figures. If there is a discrepancy between unit prices, total price quoted in words and figures, the Arithmetical errors will be rectified on the following basis.
 - a. If there is a discrepancy between the unit price and the total price, which is obtained by multiplying the unit price and quantity, or between subtotals and the total price, the unit or subtotal price shall prevail, and the total price shall be corrected.
 - b. If there is a discrepancy between words and figures, the amount in words shall prevail.
- b) In case of any other discrepancy, the decision of the purchaser will be final.

ENGINEER/PURCHASE

SPECIAL TERMS AND CONDITION

1. Unloading of material at site shall be in BHEL's scope.
2. Price in INR should be quoted for **F.O.R destination delivery at BHEL site offices Lalitpur.**
3. **EVALUATION CRITERIA:** On total cost to BHEL for whole lot. BHEL reserves the right to conclude the contract either on Ex- works or F.O.R site basis at its sole discretion. However bidder to submit Prices on F.O.R site basis.

4. **TAXES AND DUTIES:**

4A) Price quoted should be inclusive of all the applicable charges, Taxes and Duties. However rates of Sales Tax, Excise Duty & other statutory levies should be indicated separately if applicable. Variation in Excise Duty, Sales Tax/ Vat or any other statutory levies during contractual delivery period shall be to BHEL's account. BHEL shall issue ROAD PERMITS, wherever applicable, to the supplier. Any other govt. levies as per actuals shall be reimbursed by BHEL on submission of relevant documentary proof by supplier.

4B) Excise duty incurred by seller/contractor on items against the dispatch constituting a sale under the order alone shall be reimbursed at actuals against requisite documentary evidence. The invoice cum excise duty gate pass (excise invoice) should contain the name of ultimate consignee as specified in the order. Hence CENVAT benefit during evaluation of price shall be considered in the following cases where

4B1) Invoice issued by Manufacturer / first stage dealer and second stage dealer as per the provision of Rule 11 of Central Excise Rules, is also declared as duty paying document for the purpose of allowing CENVAT credit under rule 9 of CENVAT Credit Rules, 2004. It is noted that Invoice issued by registered dealer shall be prepared in triplicate and indicate at the top of the Invoice in bold capital letters as "First Stage Dealer" or "Second Stage Dealer".

4B2) In case goods are purchased through a dealer but these are dispatched by supplier manufacturer directly to the factory of buyer. In such case, CENVAT is available to buyer if invoice is in name of dealer but name of buyer is shown as consignee. This termed as Transit Invoice where Invoice is in name of dealer with name of buyer-manufacturer as consignee.

4B3) In case goods are dispatched from the godown of First stage dealer or second stage dealer. The credit of duty on inputs or capital goods purchased from first stage dealer or second stage dealer shall be allowed only if the said dealer has maintained records indicating the fact that the inputs or capital goods were supplied from the stock on which duty was paid by manufacturer of such goods and only an amount of such duty has been indicated in the invoice issued by him. (Ref.: Circular No. 689/5/2003-CX dated 14.01.2003).

4B4) In case supplier fails to submit the requisite and appropriate CENVATABLE invoice in favor of BHEL with CENVAT credit equal to the amount offered by them in their quote , the same shall not be payable.

Quoted rates shall remain firm except for variation in Duties / Taxes as mentioned at serial no. 4A) above.

INSPECTION AND TESTING:

5. The supplier shall offer the **OFFLINE 3 STAGE OIL FILTRATION TROLLEY** for inspection demo at works (Pre-dispatch Inspection) as per international norms. Inspection shall be carried out in presence of BHEL engineers or its nominated representative. Expenses towards Travelling / Boarding and Lodging of visiting inspection Engineer shall be to BHEL Account. However all testing arrangements shall be to supplier. Supplier has to intimate (at least 7 days in prior and in writing) for inspection of above material at their works. However if there is any delay in inspection by BHEL, the same will be on BHEL's account. BHEL reserves the right to opt for Inspection on receipt at destination.
6. **Delivery:** The delivery for all above items shall be **within 12 WEEKS** from date of P.O. to the date of dispatch. LR/ GR/ RR date for indigenous supplies shall be treated as the date of dispatch for levying

LD. “However Bidders are requested to quote realistic delivery period. Delivery extension without levy of LD shall only be granted after proper delay analysis, if delay is not attributable to Supplier”. Bidders to note the following:

- (i) Scanned copy of P.O. shall be emailed.
- (ii) General Arrangement (GA) Drawings if required and Quality Plan, to be submitted within one week from the date of P.O. Vendor may e-mail the same to save time.
- (iii) Comments/Approval will be sent through e-mail within 4-5 days from the date of receipt of GA Drawings/Quality Plan.
- (iv) Supplier shall inform the readiness of required items and offer for pre dispatch inspection within 6-8 weeks after acceptance of P.O. or approval of GA DRAWINGS/ Quality Plan.
- (v) Testing & on site Commissioning shall be completed within three weeks from the date of receipt of material at site.
- (vi) Supplier to depute their representative during unloading of material. However BHEL shall provide a suitable place for storage of material and one single electrical point free of cost at site and all other tools and tackles required for testing & on site commissioning which shall be arranged by supplier within the quoted rates.

Note: Bidders are requested to arrange the transporters and dispatch the goods on our behalf on freight (including transit insurance) pre-paid basis. Goods to reach at destination within reasonable time say 2 weeks.

7. VALIDITY OF OFFER: Offers should be valid for a period of 90 days from the date of Techno-Commercial bid (Part-I) opening.

8. The following items are to be furnished/supplied/confirmed by the vendor at the time of delivery of the above instrument :

- a. Calibration Certificate to be provided.
- b. O& M instruction manual to be provided by supplier/OEM in original (OEM COPY).
- c. Warrantee/Guarantee certificates to be provided by the supplier/OEM (12 months from the date of commissioning)
- d. Certificate of NEWNESS to be provided by supplier for the above items along with dispatch of material.

9. ACCESSORIES: All necessary probes, accessories, CD's, RS232 Interface facility (if any) to be supplied with the equipment.

10. INSPECTION, DEMONSTRATION & TRAINING: Inspection will be done at vendor's works (**VENDOR HAS TO MAKE ALL THE NECESSARY ARRANGEMENTS FOR THE SAME**). Demonstration and training will be conducted at BHEL site in presence of BHEL's Engineer and Vendor's representative (**BHEL WILL PROVIDE OIL FOR DEMONSTRATION AT SITE**). **Vendor to prove oil purification level to NAS 5 quality during demonstration at BHEL Site.**

11. SCOPE:

- a) SUPPLY
- b) INSPECTION
- c) DEMONSTRATION
- d) TRAINING

12. Tenderers shall elaborate on the service network and spare parts availability, which are to be ensured to maintain the equipment after initial commissioning and completion of warranty period. In

case service/spare parts facilities are not available in India, tenderers shall indicate the maximum possible time in making such services available from places outside India.

13. The tenderers shall also provide free visits of their service engineer from manufacturer's works / service centers for attending the faults during the warranty period in case of any complaint by the end user.

14. The equipment being offered should be of robust design and suitable for operations in Indian climatic conditions such as saline atmosphere, ambient temperature up to 50 degrees Centigrade. The electrical and controls should be tropicalized to withstand such climatic conditions.

15. Payment Terms: Tenderer shall adhere to the following payment terms:-

- a) 90% of Ex-Works value of 3 STAGE FILTRATION TROLLEY with 100% taxes, duties, freight, packing & forwarding and freight & insurance within 30 days of receipt of the material at destination.
- b) 10% of Ex-Works value shall be released after successful commissioning of above item & submission of all final documents including warranty cards, Test certificates, as applicable, commissioning certificate issued by BHEL and PBG as per clause 17 of STC.

A bank guarantee equal to 10% of the Order value excluding taxes & duties valid up to 12 months from the date of commissioning or 18 months from date of supply, whichever is earlier shall be submitted at the time of claiming 10% final payment as per Sl. no. (b) Above.

NOTE: COMMISSIONING WILL BE COMPLETED WITHIN 6 MONTHS OF SUPPLY OF INSTRUMENTS. HOWEVER IF ANY DELAY IS THERE DUE TO SOME REASONS ATTRIBUTED TO BHEL; THE SAME SHALL BE TREATED AS DEEMED COMPLETED.

The set of dispatch documents for 90% payment shall be as follows:-

- 1) Original tax Invoices
- 2) Original copy of Packing List
- 3) Calibration certificate.
- 4) Warranty Certificate for the goods
- 5) Catalogue of model supplied with O&M Manual (2 sets with OFFLINE 3 STAGE FILTRATION TROLLEY).
- 6) Certificate confirming, "Goods supplied are new".

NOTES:-

- (i) Tenderers are required to specifically confirm acceptance of these payment terms in their techno-commercial offer.
- (ii) No advance shall be paid.

16. PAYING AUTHORITY:

Manager /FINANACE, BHEL - PSNR, NOIDA

17. Warranty:

The **OFFLINE 3 STAGE OIL FILTRATION TROLLEY** offered shall carry a warranty for a period of 12 months from the date of commissioning or 18 months from date of dispatch of material at site whichever is early.

Rectification / replacement required during the warranty period will be arranged by the supplier free of cost including to and fro transport charges and import duty/excise duty/other taxes/insurance etc. payable on replacement items.

TENDER NO: BHEL/PSNR/SCP/RD/ E-2505 Dtd. 27.11.2013

Supplier to submit the Performance Bank Guarantee (PBG) equivalent to **10% of the Order value excluding taxes & duties** which shall be valid up to 12 months from the date of commissioning or 18 months from date of supply whichever is earlier.

18. No enhancement of Price, whatsoever the cause, will be allowed once the offer is accepted and the order is placed. Withdrawal of the offer after it is accepted or failure to make the supply within the schedule period will entail cancellation of purchase order and purchase at the risk and cost of supplier.

19. The quantity of item to be purchased may vary according to actual requirement at the time of placement of order.

20. REVERSE AUCTION: "BHEL reserves the right to go for Reverse Auction (RA) instead of opening the sealed envelope price bid, submitted by the bidder. This will be decided after techno-commercial evaluation. All bidders to give their acceptance for participation in RA. Non-acceptance to participate in RA may result in non-consideration of their bids, in case BHEL decides to go for RA. In case BHEL decides to go for Reverse Auction, only those bidders who have given their acceptance to participate in RA will be allowed to participate in the Reverse Auction. Those bidders who have given their acceptance to participate in Reverse Auction will have to necessarily submit „online sealed bid“ in the Reverse Auction. Non-submission of „online sealed bid“ by the bidder will be considered as tampering of the tender process and will invite action by BHEL as per extant guidelines in vogue." **For details please refer to Annexure – 8.**

21. If any bidder belongs to **MSME** including SC/ST owned industry please clearly mention in your bid and provide supporting documents.

22. In case of any contradiction between General Terms & Conditions (GTC) and Special Terms & Conditions of Contract (STC), the latter shall prevail

ENGINEER/PURCHASE

ANNEXURE-"4"

GENERAL TERMS & CONDITIONS

1. Manufacturer's name, their trade mark and brand, if any should invariably be mentioned in the tender and illustrative leaflets in duplicate giving technical particulars etc. should be attached to the tender, to facilitate consideration of the offer.
2. Materials should be of best quality and correct to specifications, relevant DIN/ISO/ANSI standard or any other equivalent INTERNATIONAL standard specification as per technical specifications of tender.
3. Correct date of affecting supplies in the event of an order from this office should be recorded in the tender.
4. Please note that our terms of payment are as per clause 15 of "SPECIAL TERMS AND CONDITIONS".
All payments shall be done through Electronic Funds Transfer supplier shall submit bank details with bill invoices .In case of payment through, Bank all incidental charges will be to the Beneficiary's account.
5. Bharat Heavy Electricals Limited does not bind itself to accept the lowest tender, but reserves to itself the right to accept or reject all or part of any tender at its discretion.
6. No enhancement of rate, whatsoever the cause, will be allowed once the offer is accepted and the order is placed. Withdrawal of the offer after it is accepted or failure to make the supply within the schedule period will entail cancellation of purchase order and purchase at the risk and cost of supplier.
7. The quantities of each item to be purchased may vary according to actual requirement at the time of placement of order.
8. Where Sales Tax is payable extra, it will only be paid if registration numbers both under local sales tax/VAT and Central Sales Tax are specifically mentioned on the invoice. Tenderers should invariably quote their sales tax Registration No. in the offer.
9. **Liquidated Damages:** The LD shall be 0.5% of the total order value per week of delay or part thereof subject to a maximum of 10% of the total order value.
In case of any amendment/revision, the LD shall be linked to the amended/revised PO value.
10. **Risk Purchase:** - Alternatively, the purchaser at his option, will be entitled to terminate the contract and to purchase elsewhere at the risk and cost of the seller either the whole or any part of the goods which the supplier fails to deliver or dispatch within the time stipulated as aforesaid, or if the same were not available, the best and the nearest available substitute therefore. The seller shall be liable for any loss, which the purchaser may sustain by reason of such risk purchase in addition to L.D. at the rate mentioned in clause 9 above.
11. **Inspection:** All goods and work are subject to our inspection either at manufacture's works or after delivery as may be agreed. The decision of BHEL shall be final. Rejected goods will be returned to the supplier at his cost including freight on original shipment.
12. **Insurance:** - Wherever specifically agreed to, the supplier will insure at his cost the goods for all transit risks. In all other cases, supplier must furnish particulars of dispatch i.e. station of dispatch and destination, name of the goods, number of cases and their weights, value of the goods including all taxes, duties, levies and freight etc. for each consignment immediately after

the dispatch of goods. Failure to do this will make the supplier responsible for making good any loss which might have otherwise been recovered from insurers.

Note: However, the supplier shall still remain responsible for defective parts or short supply and defective packing.

13. **Metric System**: - Suppliers are requested to give metric measurements while quoting.
14. **Arbitration** : All disputes between the parties to the contract arising out of or in relation to the contract, other than those for which the decision of the Engineer or any other person is by the contract expressed to be final and conclusive, shall after written notice by either party to the contract to the other party, be referred to sole arbitration of the General Manager or his nominee. The arbitration shall be conducted in accordance with the provisions of the Arbitration and Reconciliation Act, 1996 the place of Arbitration shall be New Delhi (India).
15. Any suites in respect of this contract shall have the jurisdiction of the courts of New Delhi (India) only.

ENGINEER/PURCHASE

ANNEXURE-“5”**UNPRICE FORMAT (TO BE SUBMITTED WITH TECHNICAL BID)**

Sl.No.	DESCRIPTION	REMARKS
A		
1.	Design, manufacture, supply, installation & commissioning of “Off line three stage filtration trolley” (refer the attached scheme) to purify oil to NAS_5 <u>quality</u> AS PER SPECIFICATION ENCLOSED IN ANNEXURE-1 INCLUDING TWO SETS. OF SPARE FILTERS OF EACH TYPE IN ADDITION TO THE ONE SET OF FILTERS WHICH WILL REMAIN IN ASSEMBLED CONDITION FOR LALITPUR SITE	QUOTED IN THE PRICE BID
2.	PACKING AND FORWARDING CHARGES	QUOTED IN THE PRICE BID
3.	EXCISE DUTY & CESS (IF APPLICABLE AS PER CL 4 OF STC)	QUOTED IN THE PRICE BID RATE OF DUTY.....
4.	ST/VAT WITHOUT “C” FORM	QUOTED IN THE PRICE BID RATE OF DUTY.....
5.	TRANSPORTATION / FREIGHT CHARGES & INSURANCE CHARGES FROM MANUFACTURER WORK PLACE TO BHEL Site Office, Lalitpur Super Thermal Power Project, Village Mirchwara, P.O. Buragaon, Tehsil Mahroni, Distt. Lalitpur (U.P.) (QTY= 1 NOS.)	QUOTED IN THE PRICE BID
6.	OCTROI & OTHER LEVIES, IF ANY	QUOTED IN THE PRICE BID
7.	TOTAL ORDER VALUE ON F.O.R SITE BASIS	QUOTED IN THE PRICE BID
8.	CENVAT CREDIT BENEFIT TO BHEL (AS PER CL 4 OF STC)	QUOTED IN THE PRICE BID
9.	NET COST TO BHEL AFTER CONSIDERING CENVAT CREDIT (SL. NO. 7 – SL. NO. 8)	QUOTED IN THE PRICE BID
10.	WARRANTY/GUARANTEE AS PER NIT	AGREED
11.	PAYMENT TERMS AS PER NIT	AGREED
12.	DELIVERY PERIOD AS PER NIT	AGREED
13.	VALIDITY OF PERIOD AS PER NIT	AGREED
14.	MFG. TEST CERTIFICATE / O&M MANUAL/CALIBRATION CERTIFICATE AS PER NIT	AGREED
15.	ANY OTHER INFORMATION	

NOTES:

- Tenders will be evaluated based on the prices quoted up to F.O.R Site basis.** Bidders are requested to quote for each and every item from 1 to 9 as indicated above. **Please indicate NIL against items not applicable.**
- Please do not quote separate charges for Commissioning of machines at BHEL/Site.**
- Incomplete offer received may not be considered.
- The Rate shall be entered in figures as well as in words. In case of difference in rates between words and figures THE LESSER OF THE TWO will be treated as valid rate.
- In case of omission in quoting any rate, the evaluation will be done considering the highest quoted rate obtained against that item but the order, if placed, will be on the lowest quoted rate obtained against that item.
- Bidders are requested to arrange the transporter and dispatch the goods on our behalf on freight (Including transit insurance) pre-paid basis. Goods to reach at destination within reasonable time say 10 days.
- Any other charges, if not specified above, may also be indicated.
- Any other Central Govt. /State Govt. taxes, Levies applicable, if not specified above, shall be reimbursed as per actual on submission of documentary proof from the concerned Govt. office.

(Signatures of the Bidder with Name, Designation & Company's Seal)

ANNEXURE-“6”**RATE SCHEDULE (TO BE SUBMITTED WITH PRICE BID)**

Sl. No.	DESCRIPTION	Amount (Rs.)
	Design, manufacture, supply, installation & commissioning of “Off line three stage filtration trolley” (refer the attached scheme) to purify oil to NAS <u>5 quality</u> AS PER SPECIFICATION ENCLOSED IN ANNEXURE-1. INCLUDING TWO SETS. OF SPARE FILTERS OF EACH TYPE IN ADDITION TO THE ONE SET OF FILTERS WHICH WILL REMAIN IN ASSEMBLED CONDITION FOR LALITPUR SITE. - (QUANTITY 1 SET)	
1.	BASIC PRICE	
2.	PACKING AND FORWARDING CHARGES	
3.	EXCISE DUTY & CESS (IF APPLICABLE AS PER CL 4 OF STC)	
4.	ST/VAT WITHOUT “C” FORM	
5.	TRANSPORTATION / FREIGHT CHARGES & INSURANCE CHARGES FROM MANUFACTURER WORK PLACE TO BHEL Site Office, Lalitpur Super Thermal Power Project, Village Mirchwara, P.O. Buragaon, Tehsil Mahroni, Distt. Lalitpur (U.P.) (QTY= 1 NOS.)	
6.	OCTROI & OTHER LEVIES, IF ANY	
7.	TOTAL ORDER VALUE ON F.O.R SITE BASIS	
8.	CENVAT CREDIT BENEFIT TO BHEL (AS PER CL 4 OF STC)	
9.	NET COST TO BHEL AFTER CONSIDERING CENVAT CREDIT (SL. NO. 7 – SL. NO. 8)	

NOTES:

1. **Tenders will be evaluated based on the prices quoted up to F.O.R Site basis.** Bidders are requested to quote for each and every item from 1 to 9 as indicated above. Please indicate NIL against items not applicable.
2. **Please do not quote separate charges for Commissioning of machines at BHEL/Site.**
3. Incomplete offer received may not be considered.
4. The Rate shall be entered in figures as well as in words. In case of difference in rates between words and figures THE LESSER OF THE TWO will be treated as valid rate.
5. In case of omission in quoting any rate, the evaluation will be done considering the highest quoted rate obtained against that item but the order, if placed, will be on the lowest quoted rate obtained against that item.
6. Bidders are requested to arrange the transporter and dispatch the goods on our behalf on freight (Including transit insurance) pre-paid basis. Goods to reach at destination within reasonable time say 10 days.
7. Any other charges, if not specified above, may also be indicated.
8. Any other Central Govt. /State Govt. taxes, Levies applicable, if not specified above, shall be reimbursed as per actual on submission of documentary proof from the concerned Govt. office.

(Signatures of the Bidder with Name, Designation & Company's Seal)

ANNEXURE-“7”

CERTIFICATE OF NO DEVIATION

TENDER No. : BHEL/PSNR/SCP/RD/E-2505

I/ WE, M/s _____

HEREBY CERTIFY THAT NOT WITHSTANDING ANY CONTRARY INDICATIONS / CONDITIONS ELSEWHERE IN OUR OFFER DOCUMENTS, I/WE HAVE NEITHER SET ANY TERMS AND CONDITIONS NOR THERE IS ANY DEVIATION TAKEN FROM THE CONDITIONS OF BHEL'S TENDER SPECIFICATIONS, EITHER TECHNICAL OR COMMERCIAL, AND I/WE AGREE TO ALL THE TERMS AND CONDITIONS MENTIONED IN BHEL'S TENDER SPECIFICATION WITH ASSOCIATED AMENDMENTS & CLARIFICATIONS.

(Signatures of the Bidder with Name, Designation & Company's Seal)

ANNEXURE-“8”

REVERSE AUCTION (RA) FORMAT

BHEL reserves the right to go for Reverse Auction (RA) instead of opening the sealed envelope price bid, submitted by the bidder. This will be decided after techno-commercial evaluation. Bidders are also required to furnish following details in their techno-commercial bid, for this purpose.

Information and general terms and conditions governing RA are given below.

In case BHEL decides to process the tender through Reverse Auction Process (RA), following details shall be required from the bidders for their authorized representative who will participate in the on line Reverse Auction Process;

(a) Name of Designation of official:

(b) Postal Address (Complete):

(c) Telephone Nos. (Land line & Mobile both):

(d) FAX No.:

(e) E-mail address:

(f) Name of Place/State/Country, wherefrom he will participate in the RA:

(Signatures of the Bidder with Name, Designation & Company's Seal)

TERMS & CONDITIONS OF REVERSE AUCTION

Against this enquiry for the subject item/ system with detailed scope of supply as per enquiry specifications, BHEL may resort to "REVERSE AUCTION PROCEDURE" i.e., ON LINE BIDDING (THROUGH A SERVICE PROVIDER). The philosophy followed for reverse auction shall be English Reverse (No ties).

1. For the proposed reverse auction, technically and commercially acceptable bidders only shall be eligible to participate.
2. Those bidders who have given their acceptance for Reverse Auction (quoted against this tender enquiry) will have to necessarily submit „online sealed bid“ in the Reverse Auction. Non-submission of „online sealed bid“ by the bidder for any of the eligible items for which techno-commercially qualified, will be considered as tampering of the tender process and will invite action by BHEL as per extant guidelines in vogue.
3. BHEL will engage the services of a service provider who will provide all necessary training and assistance before commencement of on line bidding on internet.
4. In case of reverse auction, BHEL will inform the bidders the details of Service Provider to enable them to contact & get trained.
5. Business rules like event date, time, bid decrement, extension etc. also will be communicated through service provider for compliance.
6. Bidders have to fax the Compliance form before start of Reverse auction. Without this, the bidder will not be eligible to participate in the event.
7. In line with the NIT terms, BHEL will provide the calculation sheet (e.g., EXCEL sheet) which will help to arrive at "Total Cost to BHEL" like Packing & forwarding charges, Taxes and Duties, Freight charges, Insurance, Service Tax for Services and loading factors (for non-compliance to BHEL standard Commercial terms & conditions) for each of the bidder to enable them to fill-in the price and keep it ready for keying in during the Auction.
8. Reverse auction will be conducted on scheduled date & time.
9. At the end of Reverse Auction event, the lowest bidder value will be known on auction portal.
10. The lowest bidder has to fax/e-mail the duly signed and filled-in prescribed format for price breakup including that of line items, if required, as provided on case-to-case basis to Service provider within two working days of Auction without fail.
11. In case BHEL decides not to go for Reverse Auction procedure for this tender enquiry, the Price bids and price impacts, if any, already submitted and available with BHEL shall be opened as per BHEL's standard practice.
12. Bidders shall be required to read the "Terms and Conditions" section of the auctions site of Service provider, using the Login IDs and passwords given to them by the service provider before reverse auction event. Bidders should acquaint themselves of the „Business Rules of Reverse Auction“, which will be communicated before the Reverse Auction.
13. If the Bidder or any of his representatives are found to be involved in Price manipulation/ cartel formation of any kind, directly or indirectly by communicating with other bidders, action *as per extant BHEL guidelines*, shall be initiated by BHEL and the results of the RA scrapped/ aborted.
14. The Bidder shall not divulge either his Bids or any other exclusive details of BHEL to any other party.
15. In case BHEL decides to go for reverse auction, the H1 bidder (whose quote is highest in online sealed bid) may not be allowed to participate in further RA process.

ANNEXURE-“9”**Formats for execution of Performance Bank Guarantees:**

Note:- The Bank Guarantee bonds (BG) are to be submitted on non-judicial stamp paper of Rs. 100/- and should be only from any one of the below mentioned Banks, (1.State Bank of India, 2.State Bank of Hyderabad, 3.State Bank of Travancore, 4.State Bank of Mysore, 5.Canara Bank, 6.Bank of Baroda, 7.Punjab National Bank, 8.Deutsche Bank, 9.HDFC Bank, 10.Standard Chartered Bank, 11.Citi Bank, 12.Standard Chartered Grindlays Bank & 13.Bank of America)OR mutually agreed at the time of establishing the PBG

PERFORMANCE BANK GUARANTEE

1. In consideration of **BHARAT HEAVY ELECTRICALS LIMITED, POWER SECTOR NORTHERN REGION** (hereinafter called the "**Company**" having agreed from M/s _____ (hereinafter called the said **Contractor** which term includes supplier for the purpose of the bond) to accept the demand under the terms and conditions of the Agreement No. _____ dated _____ made between _____ and _____ (hereinafter called the said **agreement**) of Security Deposit for the due fulfillment by the said contractor of the terms and conditions contained in the said Agreement, on production of a Bank Guarantee for Rs. _____ (Rupees _____ only) we, _____ (indicate the name of the **Bank**) _____ (hereinafter referred to as the **Bank**) at the request of _____ [Contractor(s)] do hereby undertake to pay to the Company an amount not exceeding Rs. _____ against any loss or damage caused to or suffered by or would be caused to or suffered by the Company by reasons of any breach by the said Contractor(s) of any of the terms and conditions contained in the said Agreement.
2. We, _____ (indicate the name of the Bank) _____, do hereby undertake to pay the amounts due and payable under this guarantee without any demur, merely on a demand from the Company stating that the amount claimed is due by way of loss or damage caused to or would be caused to or suffered by the company by reasons of breach by the said Contractor(s) of any of the terms or conditions contained in the said Agreement or by reasons of the Contractor(s) failure to perform the said Agreement. Any such demand made on the bank, shall be conclusive as regards the amount due and payable by the Bank under this guarantee. However, our liability under this guarantee shall be restricted to an amount not exceeding Rs. _____.
3. We undertake to pay to the Company any money so demanded notwithstanding any dispute or disputes raised by the Contractor(s) in any suit or proceeding pending before any Court or Tribunal relating thereto our liability under this present being absolute and unequivocal.

The payment to so made by us under this bond shall be a valid discharge of our liability for payment thereunder and the Contractor(s) shall have no claim against us for making such payment.

4. We, _____ (indicate the name of the Bank) _____ further agree that the guarantee herein contained shall remain in full force and effect during the period that would be taken for the performance of the said Agreement and that it shall continue to be enforceable till all the dues of the Company under or by virtue of the said Agreement have been fully paid and its claim satisfied or discharged or till _____ office/ Department/ Division of Bharat Heavy Electricals Limited certifies that the terms and conditions of the said Agreement have been fully and properly carried out by the said contractor(s) and also including the satisfactory performance of the equipment during guarantee period and accordingly discharge this guarantee. Unless a demand or claim under this guarantee is

made on us in writing on or before the _____ * __, we shall be discharged from all the liability under this guarantee thereafter.

5. We, _____ (indicate the name of the Bank) _____ further agree with the Company that the Company shall have the fullest liberty without our consent and without affecting in any manner our obligations hereunder to vary any of the terms and conditions of the said Agreement or to extend time of performance by the said contractor(s) from time to time or to postpone for any time or from time to time any of the powers exercisable by the company against the said contractor(s) and to forbear or enforce any of the terms and conditions relating to the said Agreement and we shall not be relieved from our liability by any reason of any such variation or extension being granted to the said contractor(s) or for any forbearance, act or omission on the part of the company or any indulgence by the company to the said contractor(s) or by any such matter or thing whatsoever which under the law relating to sureties would but for this provision have effect of so relieving us.

6. This guarantee will not be discharged due to the change in the constitution of the Bank or the Contractor(s).

7. We, _____ (indicate the name of the Bank) _____ lastly undertake not to revoke this guarantee during its currency except with the previous consent of the Company in writing.

Date _____ Day of _____
for _____ (indicate the name of the Bank) _____

(Signature of Authorised signatory)

- * This date to be indicated should not be earlier than 60 days after the date contemplated under the contract.

FORMAT FOR E-PAYMENT DETAILS: - BHEL-PSNR-NOIDA

(To be given in letterhead along with a copy of cancelled cheque / certification from bank)

Beneficiary Name :

Bank Name & Branch :

MICR Code (9 Digits) :

IFSC CODE (For NEFT) :

Beneficiary Account No. :

Beneficiary E-mail ID :
(For payment confirmation)

(Signatures of the Bidder with Name, Designation & Company's Seal)