

TENDER DOCUMENT

TENDER SPECIFICATION No : **BAP:CTS:OT:02 / 2012-13 Dt. 05.02.2013**

NAME OF WORK:

ELECTRICAL WORK FOR SEWAGE TREATMENT PLANT (STP) IN BHEL TOWNSHIP,
RANIPET – 6.

PERIOD OF CONTRACT : 3 MONTHS

Issued to M/s. :

PART – I – TECHNICAL BID

(or Qualification Bid)

(Pages 1 – 48)



CIVIL TOWNSHIP DEPARTMENT
BHARAT HEAVY ELECTRICALS LIMITED

(A Government of India Undertaking)

BOILER AUXILIARIES PLANT

INDIRA GANDHI INDUSTRIAL COMPLEX

RANIPET – 632 406

CONTENTS

CHAPTER	DESCRIPTION	PAGE
1	NOTICE INVITING TENDER	3
2	IMPORTANT NOTE TO BIDDERS & SPECIAL TERMS & CONDITIONS TO ENQUIRY	4, 5
3	QUALIFICATION REQUIREMENTS (QR)	6,7
4	DETAILS TO BE FILLED BY CONTRACTOR	8
5	TERMS & CONDITIONS OF REVERSE AUCTION RULES	9-18
6	CERTIFICATE OF NO DEVIATION	19
7	BRIEF SCOPE OF WORK & SPECIAL CONDITIONS	20
8	ACCEPTANCE FOR EFT	21
9	GENERAL CONDITIONS OF CONTRACT	22-42
10	SPECIAL INSTRUCTIONS TO BIDDERS	43-48
11	PART – II – PRICE BID	49- 55
12	SPECIAL INSTRUCTIONS	56- 58



Bharat Heavy Electricals Limited

(A Government of India Undertaking)

BOILER AUXILIARIES PLANT

RANIPET – 632 406, INDIA

Phone No.:04172-284747

FAX No.:04172-242026

E-mail: crsekar@bhelrpt.co.in

**CIVIL TOWNSHIP DEPARTMENT
REGISTERED POST WITH ACK.DUE**

NOTICE INVITING TENDER

Tender Notice No	BAP:CTS:OT:02 / 2012-13 DT.05.02.2013
Name of work	ELECTRICAL WORK FOR SEWAGE TREATMENT PLANT (STP) IN BHEL TOWNSHIP, RANIPET - 6
Type of tender	Open tender
Period of contract	Three Months
Earnest Money Deposit (EMD) Amount	Rs. 20,000/- (Rs. Twenty thousand only)
Last date & Time for Receipt of the Tender	11.03.2013 @ 15.00 Hrs.
Date of Technical bid Opening	11.03.2013 @ 15.00 Hrs.
(Please obtain updated information from the website about the latest applicable dates & other changes if any in the tender contents)	
Date of Price Bid Opening	Bidders whose technical bids are found acceptable will be intimated separately about the status of their offers and the date of opening of Price Bid / Reverse auction.
Place of submission of Tender	Tender Box placed in Manager / Civil Township Office, Near Mukundarayapuram Railway station, BHEL Township, Ranipet – 632 406
Address on the Sealed Tender Cover to be:	MANAGER / ELECTRICAL CIVILTOWNSHIP DEPARTMENT BHARAT HEAVY ELECTRICALS LIMITED BOILER AUXILIARIES PLANT RANIPET – 632 406, VELLORE DISTRICT TAMIL NADU
Venue of the Tender Opening	CIVIL TOWNSHIP OFFICE
<ol style="list-style-type: none">1. The Tender documents can be down loaded from BHEL website (http://www.bhel.com/tender/list_tender.php) and Govt tender web site: http://tenders.gov.in/ and also in Central Public Procurement Portal (CPP) website: http://eprocure.gov.in/epublish/app2. Interested bidders may alternately collect hard copy of tender specification documents at free of cost from Civil Township Dept. / BHEL / Ranipet on all working days (between 10.00 to 15.00 hrs) except Sundays and Holidays.3. BHEL reserves the right to accept or reject any or all tenders without assigning any reasons whatsoever.4. All corrigenda, addenda, amendments, clarifications etc. to tender specification will be hosted in the web page (www.bhel.com > Tender notifications > view corrigendum) only and not in the news papers. Bidders shall keep themselves updated with all the such developments.5. BHEL reserves the right to reject any tender on the basis of unsatisfactory performance of the bidder in any on going job or any similar job in the past.	

IMPORTANT NOTE TO BIDDRES

Bidders are requested to submit their offers 'in a sealed cover' consisting of three inner sealed covers such as (1) EMD cover containing DD, (2) Technical Bid cover &,(3) Price Bid cover, all super scribing the name of the work, Tender Number, Due date etc.

- 1) EMD cover shall contain requisite EMD in the form of cash (as permissible under income tax act), Pay order or Demand Draft (DD). Bidders who have already remitted one time EMD of Rs. 2 Lakh need not submit the DD. However they have to furnish the details of Cash Receipt No. & Date on the top of the EMD cover. Tender without EMD / One time EMD reference will be summarily rejected. EMD in any other form will not be accepted.**
- 2) Technical/Qualification bid cover shall contain duly filled in qualification bid document signed by the bidder in all the pages with documentary evidences for pre-qualification such as Balance sheet, P&L A/c, experience, value of work executed in the similar nature of work etc. Any bid without proper documentary evidence for pre-qualification shall not be considered for further evaluation.**
- 3) The price bid cover shall contain price bid document(BHEL format only) duly filled in and signed by the bidder in all the pages. The bidder has to quote most competitive rates for all the items in the price bid. The completed qualification bid and price bid along with requisite EMD of Rs 20,000 /- for the work in the form of Demand Draft drawn from any Nationalized bank, in favor of 'Manager / Finance, BHEL, Ranipet' payable at SBI, Mukundarayapuram Branch (Code : 7013) shall reach the Office of the undersigned on or before 11.03.2013 at 15.00 Hrs.**

(This earnest money deposit will be refunded to the unsuccessful Bidders after finalization of the award of work. In case of successful bidder, the earnest money will be retained as part of the Security Deposit for satisfactory completion of the work in accordance with BHEL's General Conditions of Contract enclosed. No interest will be paid on the earnest money deposit. EMD by the bidder will be forfeited if i) After opening the tender / price bid/completion of Reverse Auction process the bidder revokes his tender within the validity period or increases his earlier quoted rates ii) The bidder does not commence the work within the period as per LOI / Contract. In case the LOI / Contract is silent in this regard then within 15 days after award of contract).

- 4) The Qualification/ Technical bid will be opened on 11.03.2013 at 15.00 hrs onwards . In case of opening day falls on holiday or happened to be declared as a holiday the receipt and opening of the Tender shall automatically fall at the same timing on the next working day. Date and time of opening of the price bid/ Reverse auction shall be intimated to those bidders who have qualified in the technical bid. The bidders or their authorized agents can participate in the tender opening for which they shall bring authorization letter for attending tender opening.**

5) Bidders are required to submit their price bid in the BHEL format only .

- 6) Seeking clarification on Tender Specification : Clarifications on tender specification if any may be sought by the bidders during the office hours only from the **Manager/Electrical/ Civil Township** phone no -04172-284747, mobile no: 9443625498 .**

[IMPORTANT NOTE:- BIDDERS SHALL SIGN & AFFIX THEIR SEAL IN ALL PAGES OF THIS TENDER DOCUMENT (TECHNICAL BID & PRICE BID) AND SUBMIT ALONG WITH ALL OTHER DOCUMENTS AS CALLED FOR IN THE TENDER]

- 7) All the information as called for in the various clauses and annexure of tender specification should be furnished. Please refer to the check list. The details so furnished should be complete in all respects and as per the formats prescribed in the Tender specification (Statutory requirement of Contract). The bidder may have to produce original documents for verification, if so decided by BHEL.
- 8) Offers received with any deviation or without relevant information are liable to be rejected.
- 9) Price bids received in any form other than prescribed in PRICE BID are liable to be rejected.
- 10) **The bidder has to quote his Rate for all individual items in the Rate Schedule of Price Bid. If the bidder has not quoted the Rate for any item(s), it is considered as incomplete tender and tender can not be accepted.**
- 11) **The tender offer should be kept valid for THREE MONTHS from the date of Price bid opening** for acceptance by BHEL. No unsolicited revision in the tender offer shall be entertained after opening of tenders and till expiry of the validity period.
- 12) **REVERSE AUCTION:** BHEL Reserves the right to adopt the process of **Reverse Auction** (ON LINE BIDDING on INTERNET) among the bidders who are found to be qualified on the basis of technical bid. Refer the **Terms and Conditions of reverse auction** in Pages **09 to 18**. No extension of time on this account will be entertained for bid submission
- 13) Quoted rates shall be firm through out the contract period and extended period also and no cost escalation is allowed on any account.
- 14) **The similar works executed in the own name of the bidder only will be considered for eligibility / qualification criteria.**

SPECIAL TERMS AND CONDITIONS TO ENQUIRY

1. BHEL reserves the right to increase or decrease the tendered quantity.
2. Lowest prices received against BHEL tenders need not be the technically acceptable one, and in that case, BHEL reserves the right not to consider the same.
3. BHEL reserves the right to negotiate or refloat the tender opened, if L1 Price is not lowest acceptable price to them inter-alia other reasons.
4. BHEL reserves the right to negotiate the L1 rate.
5. The contract will be finalized based on the overall LOWEST value and to be awarded to single party only since split in schedules is not possible.

Clarification if any can be obtained from the undersigned before submitting the offer.

Kindly acknowledge the receipt of the entire set of tender document.

QUALIFICATION REQUIREMENTS (QR) :

Name of work: ELECTRICAL WORK FOR SEWAGE TREATMENT PLANT (STP) IN BHEL TOWNSHIP, RANIPET - 6

Tender Notice No: BAP:CTS:OT:02 / 2012-13 DT.05.02.2013

S.No	Description	Details (To be filled by the Contractor)
1	Average annual financial turnover of the Contractor during the last 3 years ending on 31st March 2012, should be at least 1.85 lakhs. and the bidder should submit audited balance sheet and Profit & Loss Account for the last three years (2009 – 10, 2010 – 11 & 2011-12), duly certified by chartered accountant / auditor.	2009 – 10: 2010 – 11: 2011 – 12:
2	Contractors having experience of successfully completed similar works (ref. Note 1 below) during the last 7 years as on 31.01.2013 should be either of the following.	
2. a	Three similar completed works each costing not less than the amount equal to Rs.2.46 Lakhs.	Client : Name of work : Value of Wok : Rs. Completion Certificate issued by : Date of completion of work: <hr/> Client: Name of work: Value of Wok : Rs. Completion Certificate issued by : Date of completion of work: <hr/> Client: Name of work: Value of Wok : Rs. Completion Certificate issued by : Date of completion of work:
OR		

2.b	Two similar completed works each costing not less than the amount equal to Rs.3.08 Lakhs.	Client: Name of work:
		Value of Wok : Rs. Completion Certificate issued by : Date of completion of work:
2.c	One similar completed work costing not less than the amount equal to 4.93 lakhs.	Client: Name of work:
		Value of Wok : Rs. Completion Certificate issued by : Date of completion of work:
OR		
3.	Contractor should have relevant valid Electrical EB / ES A / EA / ES B grade license from State Electrical Licensing Board of Tamilnadu / other states for carrying out this work.	
Note 1 : `Similar Works` mentioned in SI.No-2 above shall mean successfully executed “electrical works such as cable laying, wiring work, erection of electrical panels, distribution boxes, light fittings etc. in manufacturing / process industries / Govt. offices / public buildings / private industries”.		
The work executed in the own name of the bidder only will be considered for similar works executed for meeting the eligibility criteria		
Tender bids not meeting any of the above pre-qualification criteria shall be rejected.		

Documents required for proof of QR:

The bidders should submit documents in support of possessing Qualifying requirements as under, duly certified and stamped by their authorized signatory:

- a. Copy of Balance sheet, Profit & Loss Account duly certified & audited by Chartered Accountant and work orders along with BOQ and completion certificates in support of the qualifying criteria.
- b. Copy of authorization letter / power of attorney of the authorized signatory of the tender document (only in case of owner of the firm is different from authorized signatory).

Details to be filled by the Contractor

1a	Name of applicant	
1b	Full address	
1c	Nationality	
1d	email cell phone fax	
2	Whether the firm is individual firm or Sole proprietorship firm or partner ship firm or Hindu undivided Family or association of persons or Private Limited company or Public Limited company or any other please specify. (Notarized copy has to be enclosed)	
3	Whether the contractor has registered his workmen under employees State Insurance Act. If so, the Registration No./ Enrolment Number may be furnished. (Notarized copy has to be enclosed)	
4	PAN no and documentary proof (Notarized copy has to be enclosed)	
5	Registration under Tamil Nadu VAT ACT, TIN number . (Notarized copy has to be enclosed).	
6	The service tax heads under which the enlisting person registered with Excise Authorities and copy of service tax registration certificate has to be enclosed (Notarized copy)	
7	Whether the contractor has registered his workmen under Employees Provident Fund and Miscellaneous Provisions Act? (Notarized copy has to be enclosed).	

A) GENERAL TERMS AND CONDITIONS OF REVERSE AUCTION

BHEL, Ranipet may resort to “Reverse Auction method for finalizing the L-1 bidder through. **ON LINE BIDDING on INTERNET.**

1. For the proposed reverse auction, technically and commercially qualified bidders only can participate in the online bidding process..
2. BHEL will engage the services of a service provider who will provide all necessary training and assistance to the qualified bidders free of charge before commencement of on line bidding on Internet.
3. BHEL will inform all the technically qualified bidders in writing, the detailed procedure of the reverse auction process and the details of service provider in order to prepare them for participating in reverse auction process.
4. Business rules like event date, time, start price, bid decrement, extensions, etc. also will be communicated through service provider for compliance.
5. Vendors have to fax the compliance form in the prescribed format (provided by service provider) before start of Reverse auction. Without this the vendor will not be eligible to participate in the event.
6. BHEL will provide the calculation sheets e.g. auto formulated EXCEL sheet) for the vendor to enable them to fill-in the price and keep it ready for keying in during the action. In the event of discrepancy in rate and amount against any item of work, the least of the two will be taken for bid price. In case of discrepancy between the total price indicated in price bid and the arithmetic sum arrived based on rate quoted, then also the least of the two will be taken for the bid price. The bids are compared on the total price quoted and NOT on individual ITEM of works.
7. Reverse auction will be conducted on schedule date & time, which will be fixed and informed by the service provider.
8. At the end of reverse auction event, the lowest bidder value will be known on the network.
9. The lowest bidder has to fax the duly signed filled-in prescribed format as provided on case-to-case basis to BHEL through service provider within 24 hours of action without fail.
10. Any variation between the on-line bid value and signed document will be considered as sabotaging the tender process and will invite disqualification of bidder as per prevailing procedure.
11. **Opening bid in reverse Auction:** The ‘Opening bid’ (In the reverse Auction) of the bidder shall be ‘same as that quoted in their final sealed price’ submitted to BHEL (along with technical offer). The bidder shall confirm this in writing to BHEL before start of Reverse Auction

If any bidder offers unsolicited discount or rebate, in separate cover ect., in any place other than the sealed price bid, then the ‘opening price bid’ in reverse action, by such a bidder shall be the price offered in final sealed price bid submitted (against this NIT) minus discount offered in any place other than the sealed price bid.

12. BHEL reserves the right to cancel Reverse Auction (RA) without assigning any reasons and resort to considering the sealed bids submitted by vendor for processing and finalizing the tender.
13. In case the process of reverse auction is found unsuccessful by BHEL, then BHEL at its discretion may decide to call the L1 bidder of reverse auction for further negotiation.
14. In case BHEL decides not to go for Reverse auction procedure for this tender enquiry, the price bids and price impacts, if any already submitted and available with BHEL shall be opened as per BHEL's standard practice. Hence please quote your best lowest price in first instant itself.
15. Only those vendors, who participate in the Online Initial Opening bid, will be eligible to participate in the subsequent Online English Reverse Auction.
16. Price bids offered by the bidders during reverse auction process are considered as an offer to execute the work. Bids once made by a bidder can not be cancelled / withdrawn and bidders shall be bound to execute the work at the final bid price. BHEL shall take appropriate action if the bidder fails to do so.

Authorization of representative who will participate in the on line Reverse Action Process:

1	NAME & DESIGNATION OF OFFICIAL	
2	POSTAL ADDRESS (COMPLETE)	
3	TELEPHONE NOS. (LAND LINE & MOBILE PHONE)	
4	FAX NO	
5	E-MAIL ADDRESS	
6	NAME OF PLACE/ STATE/ COUNTRY, WHERE FROM S/HE WILL PARTICIPATE IN REVERSE AUCTION	

B) BUSINESS RULES FOR FINALIZATION OF THE PROCUREMENT / WORKS

BHEL shall finalize this tender through reverse auction mode. BHEL has made arrangement with M/s service provider who shall be BHEL's authorized service provider for the same. Please go through the guidelines given below and submit your acceptance for the same along with your Commercial Bid.

1. Computerized reverse auction shall be conducted by BHEL, on pre-specified date, while the bidders shall be quoting from their own offices/ place of their choice. Internet connectivity and other requirements shall have to be ensured by vendors themselves.
2. In extreme case of failure of Internet connectivity, (due to any reason whatsoever may be) it is the bidders responsibility / decision to send fax communication immediately to M/s _____. Furnishing the price the bidder wants to bid online with a request to the service provider to upload the faxed price on line so that the service provider will upload that price on line on behalf of the Bidder. It shall be noted clearly that the concerned bidder communicating this price to service provider has to solely ensure that the fax message is received by the service provider in a readable / legible form and also the Bidder should simultaneously check up with service provider about the clear receipt of the price faxed. It shall also be clearly understood that the bidder shall be at liberty to send such fax communications of prices to be uploaded by the service provider only within the closure of Bid time and under no circumstance it shall be allowed beyond the closure of Bid time / reverse auction. It shall also be noted that the service provider should be given a reasonable required time by the bidders, to upload such prices online and if such required time is not available at the disposal of the Service provider at the time of receipt of the fax message from the bidders, the service provider will not be uploading the prices and neither BHEL nor the service provider are responsible for this unforeseen circumstances. In order to ward-off such contingent situation bidders are requested to make all the necessary arrangements/ alternatives whatever required so that they are able to circumvent such situation and still be able to participate in the reverse auction successfully. Failure of power at the premises of vendors during the Reverse Auction cannot be the cause for not participating in the Reverse Auction. On account of this, the time for the auction cannot be extended and neither BHEL nor the service provider M/s _____ is responsible for such eventualities.
3. M/s _____, shall arrange to train your nominated person (s), without any cost to you. They shall also explain you, all the Rules related to the Reverse Auction / Business Rules Document to be adopted along with bid manual. You are required to give your compliance on it before start of bid process.
4. **Starting Bid/Bid Decrement:** The opening price shall be the lowest price of sealed bids (or as decided by BHEL) and the bid decrement shall be available to the bidders before 05 minutes of the start of the auction and the same shall be displayed on the site.
5. **BIDDING CURRENCY AND UNIT OF MEASUREMENT:** Bidding will be conducted in **Indian Rupees (INR)** of the item. The price bid placed during the "Sealed Bid Auction" as well as "Reverse Auction" shall be the total price for "all items in the Rate Schedules" of the tender (1 Lot). **i.e the total amount quoted for all the schedules along with the applicable service tax amount for the same.**
6. **BID PRICE:** The Bidder has to quote the Total cost to BHEL for the items specified. (Total cost = Total sum arrived at by adding the amounts against each item of work in the Rate Schedule plus service tax amount for the sum).

7. The technical & commercial terms are as per BHEL Tender No.: BAP:M&S:TE:EL:12:015:DT:04.10.2012 and Vendor's technical and commercial bid and subsequent correspondences between BHEL and the vendors regarding commercial terms & conditions.

8. **VALIDITY OF BIDS:** The Bid price shall be firm for a period of **Three months** from the date of completion of Reverse Auction (**or as specified in Process compliance form**) and shall not be subjected to any change whatsoever.

However if the final price in reverse auction necessitates further negotiations, BHEL reserves the right to call L-1 bidder in reverse auction for further negotiations as per the regular BHEL standard practice.

9. At the end of the reverse auction, bidder has to provide a detailed break up for his lowest offer. The ratio of **CP (Closing Price)** and originally quoted price in online initial bid shall be applied on all items of the Rate Schedule prices to arrive at the final price break up. Final price break ups have to be submitted in BHEL's excel sheets through service provider.

10. **Procedure of Reverse Auctioning:-**

i. **Sealed bid Reverse Auction:** The opening bid (in the initial auction), bidders have to enter their bid values in the prescribed online formats (provided by the service provider) which should be same as that quoted in their Final Sealed price submitted to BHEL (along with the Technical Bid) or less. The bidders shall confirm in writing to BHEL that their opening bid shall be same as that quoted in their final sealed price bid submitted to BHEL against Tender Notice No. BAP:CTS:OT;02 / 2012-13 DT.05.02.2013. If it is found to be otherwise at a later date, the bidder will be disqualified from the tender.

ii. **English Reverse (no ties) {Reverse Auction}:** BHEL will declare its **Opening Price (OP)**, which shall be visible to the all vendors during the start of the Reverse Auction. You will be required to start bidding after announcement of 'Opening Price' and 'decrement amount'. Also, please note that the start price of an item in the online reverse auction is open to the entire online reverse auction, from the start price itself. If the start price is your own Online Initial Sealed Bid price, you still need to bid in the online reverse auction. Moreover, please note that the first online bid that comes in the system during the online reverse auction can be equal to the auction's start price, or lesser than the auction's start price by one decrement, or lesser than the auction's start price by multiples of decrement .The second online bid and onwards will have to be lesser than the L1 rate by one decrement valve, Or lesser than the L1 rate by multiples of the decrement valve.

iii. Online Initial Sealed Bid auction will be for **30 minutes** and Online English Reverse (no ties) auction shall be for a **period of 60 minutes**. If a bidder places a Bid in the last 10 minutes of Closing of the Reverse Auction and if that bid gets accepted, then the auction's duration shall get extended automatically for another 10 minutes for the entire auction (i.e. for all the **items** in the auction),from the time that bid comes in.

Please note that the auto-extension will take place only if a bid comes in those last 10 minutes and if that bid gets accepted . If the bid does not accepted, the auto-extension will not take place even if that bid might have come in the last 10 minutes. In case, there is no Bid in the last 10 minutes of closing of Reverse Auction, the Auction shall get closed automatically without any extension. However Vendors are advised not to wait till the last minute or last few seconds to enter their bid during the auto-extension period to avoid complications related with internet connectivity, Network problems, system crash down, power failure, etc.

- iv. The 'bid decrement' amount shall be specified by BHEL before start of bidding.
 - v. Any commercial loading shall be intimated to bidders in advance and it shall be added to price during dynamic auction process. For evaluation purpose, commercial loading if any, shall be added to the quoted price of respective bidder. However for ordering only the final bid placed by you shall be considered.
 - vi. After the completion of English Reverse (no ties), the **Closing Price (CP)** shall be available. In case, any commercial loading was made to L1 bidder's price, it shall be de-loaded from the closing price of L1 bidder (**CP**) for further processing.
 - vii. **The ratio of CP and originally quoted price in online sealed bid shall be applied on all schedules /elements of price bid to arrive at the final price break up.**
11. Successful vendor shall be required to submit the final prices, quoted during the English Reverse (no ties) exactly in Excel formats 1 & 2 issued by BHEL / Service provider after the completion of Auction to BHEL, duly signed and stamped as token of acceptance without any new condition other than those already agreed to before start of auction.
 12. During English Reverse (no ties), if no bid is received within the specified time, BHEL, at its discretion, may decide to revise Opening price / scrap the reverse auction process / proceed with conventional mode of tendering.
 13. Your bid will be taken as an offer confirming to execute the subject work as per Tender Specification No.: BAP:CTS:OT;02 / 2012-13 DT.05.02.2013. Bids once made by you, cannot be cancelled / withdrawn and you shall be bound to supply as mentioned above at your final bid price. **Should you back out and not supply as per the rates quoted, BHEL shall take action as appropriate.**
 14. You shall be assigned a **Unique User Name & Password** by M/s _____, You are advised to change the Password and edit the information in the Registration Page after the receipt of initial Password from BHEL / M/s _____, to ensure confidentiality. All bids made from the Login ID given to you will be deemed to have been made by your company.
 15. You will be able to view the following on your screen along with the necessary fields in the English Reverse (no ties) {Reverse Auction}:
 - a. Leading Bid in the Auction (only total price)
 - b. Bid Placed by you
 - c. Opening Price.
 16. At the end of the Reverse Auction, BHEL will decide upon the winner. BHEL's decision on award of Contract shall be final and binding on all the Bidders.
 17. BHEL shall be at liberty to cancel the reverse auction process / tender at any time, before ordering, without assigning any reason.
 18. BHEL shall not have any liability to bidders for any interruption or delay in access to the site irrespective of the cause.
 19. All other terms and conditions shall be as per your techno-commercial offers and other correspondences till date.
 20. You are required to submit your acceptance to the terms / conditions/ modality given above before participating in the reverse auction.

C). TERMS & CONDITIONS OF REVERSE AUCTION:

1. **LOG IN NAME & PASSWORD:** Each Bidder is assigned a Unique User Name & Password by M/s _____, . The Bidders are requested to change the Password and edit the information in the Registration Page after the receipt of initial Password from M/s _____, All bids made from the Login ID given to the bidder will be deemed to have been made by the bidder.
2. **BIDS PLACED BY BIDDER:** The bid of the bidder will be taken to be an offer to execute the work. Bids once made by the bidder cannot be cancelled. The bidder is bound to execute the work as mentioned above at the price that they bid. Should any bidder back out and not make the supplies as per the rates quoted, BHEL and / or M/s _____, shall take action as appropriate.
3. **LOWEST BID OF A BIDDER:** In case the bidder submits more than one bid, the lowest bid will be considered as the bidder's final offer to execute the work
4. **AUCTION TYPE:** 1). Sealed bid Reverse Auction
2). English Reverse (No Ties) Auction (refer Bidder Manual for details)
5. **DURATION OF AUCTION:** The duration of English Reverse (No Ties) Auction will be for **60 minutes**. If a bidder places a bid in the **last 10 minutes** of closing of the Reverse Auction and if that bid gets accepted, then the auction's duration shall get extended automatically for another 10 minutes, for the entire auction (i.e. for all the items in the auction), from the time that bid comes in. Please note that the auto-extension will take place only if a bid comes in those last 10 minutes and if that bid gets accepted. If the bid does not get accepted, the auto-extension will not take place even if that bid might have come in the last 10 minutes. In case, there is no bid in the last 10 minutes of closing of Reverse Auction, the auction shall get closed automatically without any extension. However, vendors are advised not to wait till the last minute or last few seconds to enter their bid during the auto-extension period to avoid complications related with internet connectivity, network problems, system crash down, power failure, etc. (THIS SCHEDULE IS TENTATIVE. IF ANY CHANGE IN SCHEDULE, THE SAME SHALL BE COMMUNICATED TO YOU)
6. **BID DECREMENT:** The minimum Bid decrement shall be available to the Bidders at the start of the auction. The bidder can view the same by clicking on the Item details at the start of the auction. The bidder can bid lower than the Lowest Bid in the auction by a decrement, multiple of the minimum Bid decrement or at least of minimum bid decrement plus multiple of Bid Decrement.

Also, please note that the start price of an item in the online reverse auction is open to all the participating bidders. Any bidder can start bidding, in the online reverse auction, from the start price itself. If the start price is your own Online Initial Sealed Bid price, you still need to bid in the online reverse auction.

Moreover, please note that the first online bid that comes in the system during the online reverse auction can be equal to the auction's start price, or lesser than the auction's start price by one decrement, or lesser than the auction's start price by multiples of decrement. The second online bid and onwards will have to be lesser than the L1 rate by one decrement value, or lesser than the L1 rate by multiples of the decrement value.

7. **VISIBILITY TO BIDDER:** The Bidder shall be able to view the following on his screen along with the necessary fields during English Reverse –(no ties) Auction:
- a. Leading Bid in the Auction (only total price)
 - b. Bid Placed by you
 - c. Your Own Rank
 - d. Opening Price & Bid Decrement value.
8. **AUCTION WINNER:** At the end of the Reverse Auction, BHEL will evaluate all the bids submitted and will decide upon the winner.
9. **PROXY BIDS:** Proxy bidding feature is a pro-bidder feature to safe guard the bidders's interest of any Internet failure or to avoid last minute rush. The Proxy feature allows Bidders to place an automated bid against other Bidders in an auction and bid without having to enter a new amount each time a competing Bidder submits a new offer.

The bid amount that a Bidder enters is the minimum that the Bidder is willing to offer. Here the software bids on behalf of the bidder.

- The proxy amount is the minimum amount that the Bidder is willing to offer. During the course of bidding, the Bidder cannot delete or change the amount of a Proxy Bid.
- Bids are submitted in decrements (decreasing bid amounts). The application automates proxy bidding by processing proxy bids automatically, according to the decrement that is applicable.
- The auction originator, originally established when creating the auction, submitting offers to the next bid decrement each time a competing Bidder bids, regardless if competing bids are submitted as proxy or standard bids.

GENERAL TERMS & CONDITIONS: Bidders are required to read the "Terms and Conditions" section of the auctions site using the Login Ids and passwords given to them.

10. OTHER TERMS & CONDITIONS:

The Bidder shall not involve himself or any of his representatives in Price manipulation of any kind directly or indirectly by communicating with other suppliers / bidders.

The Bidder shall not divulge either his Bids or any other exclusive details of BHEL to any other party.

BHEL's decision on award of Contract shall be final and binding on all the Bidders.

BHEL along with M/s _____, can decide to extend, reschedule or cancel any Auction. Any changes made by BHEL and / or M/s _____, after the first posting will have to be accepted if the Bidder continues to access the site after that time.

M/s _____, shall not have any liability to Bidders for any interruption or delay in access to the site irrespective of the cause.

M/s _____, is not responsible for any damages, including damages that result from, but are not limited to negligence.

M/s _____, will not be held responsible for consequential damages, including but not limited to systems problems, inability to use the system, loss of electronic information etc.

N.B.

- All the Bidders are required to submit the Agreement Form / Process compliance Form **(ANNEXURE II)** duly signed to M/s _____, before due date (xx.xx.2013) After the receipt of the Process compliance Form, Log in ID & Password shall be allotted to the bidders.
- After the completion of the Auction event, all the Bidders have to submit the Price Breakup immediately exactly as per excel working sheet 1 & 2 issued by BHEL/service provider to M/s _____, for further proceedings, within 24 hours of completion of the Reverse Auction.

ANNEXURE- II (sample form)
Process Compliance Form

(The bidders are required to print this on their company's letter head and sign, stamp before faxing)

To

M/s _____,
XXXX , xxxx
xxxx

Auction website: [https// xxxxx.com](https://xxxxx.com)

Sub: Agreement to the Process related Terms and Conditions for the Reverse Auction

Dear Sir,

This has reference to the Terms & Conditions for the Reverse Auction mentioned in the Tender document for **ELECTRICAL WORK FOR SEWAGE TREATMENT PLANT (STP) IN BHEL TOWNSHIP, RANIPET – 6** against BHEL Tender No. BAP:CTS:OT::02 / 2012-13 DT.05.02.2013. This letter is to confirm that:

- 1) The undersigned is authorized representative of the company.
- 2) We have studied the Commercial Terms, Excel working sheets issued by M/s BHEL / M/s _____ and the Business rules governing the Reverse Auction as mentioned in your letter and confirm our agreement to them.
- 3) We also confirm that we have taken the training on the auction tool and have understood the functionality of the same thoroughly.
- 4) We also confirm that we will fax the price confirmation & break up of our quoted price as per template Excel working sheets issued by M/s BHEL / M/s _____.
- 5) We confirm that **rates are valid till three months from the date of completion of Reverse Auction.**

We, hereby confirm that we will honor the Bids placed by us during the auction process.

With regards

Signature with company seal

Name –

Company / Organization –

Designation within Company / Organization –

Address of Company / Organization –

- Sign this document and Fax at +91 xxx xxxxx
- Attach a signed copy of the RFQ document along with the Agreement Form & send to
- _____ . **Com**

Annexure III (sample form)
(Price Confirmation)

(The bidders are required to print this on their company's letter head and sign, stamp before faxing)

To,

M/s _____
XXXXX
XXXXXXXXX
XXXXXX,
XXXXXX.

Sub: Final price quoted during reverse auction and price break up

Ref: 1. BHEL Tender Enq. No. (BAP:CTS:OT;02 / 2012-13 DT.05.02.2013)
2. Reverse Auction dt.
3. Our Offer No. dt.

Dear Sir,

We confirm that we have quoted against the **Tender Enq. No.** BAP:CTS:OT;02 / 2012-13
DT.05.02.2013 as detailed below

As our final prices during the Reverse Auction conducted **on xx.xx.2013.**

Thanking you and looking forward to the valuable order from BHEL.

Yours sincerely,

For _____

Name:
Company:
Date:
Seal:

CERIFICATE OF NO DEVIATION

I / We of M/s

hereby certify that **there is no deviation** from the tender conditions either technical or commercial and I am /We are agreeing to all the terms and conditions mentioned in the Tender Specification BAP:CTS:OY:02 / 2012-13 dt. 05.02.2013..

Date:

Signature of the Bidder

BRIEF SCOPE OF WORK & SPECIAL CONDITIONS

Description of site:

- 1) All the work shall be carried out as per the instructions of BHEL engineer. BHEL engineer's decision regarding the correctness of the work and method of working shall be final and binding on the contractor.
- 2) All under ground cables are to be laid as per detailed specification enclosed which includes supply of required bricks, sand etc and trenching.
- 3) The street light poles shall be fabricated and painted as per the specification only.
- 4) The drawings of street light poles to be approved by BHEL ,Engineer before fabrication.
- 5) The concrete foundation for street light poles shall be done as per standard specification with the approval of BHEL Engineer-in-charge.
- 6) The scope of work includes, testing and commissioning of the entire equipment erected by the contractor.
- 7) The operation of street light timers to be demonstrated by the contractor.
- 8) Cable markings are to be provided by the contractor for all under ground cables laid by the contractor.
- 9) Earthing to be provided for all street light poles from the nearest earth grid.
- 10) Construction power will be provided at one point on free issue basis. Contractor has to bring required extension switch boxes with wire for using the power for drilling cutting etc.
- 11) Cable markings are to be provided as per specification .
- 12) The contractor has to co-ordinate with civil (road) contractor during laying of under ground cables and ensure smooth execution of the both works.
- 13) The contractor has to prepare necessary lay out drawings/ as built cable routing drawings and submit to BHEL for records.
- 14) Tentative time schedule for execution of the work: From March, 2013- May -2013 (3 months).
- 15) The contractor has to mobilize required men and materials to complete the work as per requirement of the BHEL to compress the time period if required..
- 16) BHEL reserves the right for extending the contract period based.
- 17) Contractor shall receive free issue cable (3.5 C x 185 sqmm) from BHEL Civil Township stores and transport it to site of work within the quoted rates. The safety & security of the BHEL's cable as well as all contractor supplied materials is the responsibility of the contractor of this work till completing and handing over to BHEL.

ACCEPTANCE FOR ELECTRONIC FUND TRANSFER / RTGS TRANSFER

01	NAME & ADDRESS OF THE SUPPLIER / VENDOR	
02	VENDOR CODE (as in WORK ORDER)	
03	Details of Bank Account:	
A)	NAME & ADDRESS OF THE BANK (WITH PIN CODE)	
B)	BANK TELEPHONE NUMBER (WITH STD CODE)	
C)	<u>BANK BRANCH CODE</u>	
D)	MICR CODE	
E)	ACCOUNT NUMBER	
F)	TYPE OF ACCOUNT	CURRENT A/C / OD / CASH CREDIT
G)	VENDOR NAME AS PER BANK RECORDS	
H)	BANK BRANCH RTGS IFSC CODE	
I)	BANK BRANCH NEFT IFSC CODE	
J)	YOUR EMAIL ID (give two ids)	
K)	NAME OF AUTHORISED SIGNATORY	

CERTIFICATE

I / We hereby agree to receive the payments due from BHARAT HEAVY ELECTRICALS LIMITED, RANIPET by the National Electronic Funds Transfer and/or RTGS Transfer mode by credit to my / our above mentioned Bank Account. I / We also agree that payments made to the above mentioned Account is a valid discharge of the liability of Bharat Heavy Electricals Limited, Ranipet. I / We also agree to bear the applicable Bank Charges for the above mode of transfer.

AUTHORISED SIGNATORY OF VENDOR WITH SEAL

Banker's Certification

We confirm that we are enabled for receiving RTGS and NEFT credits and we further confirm that the account number of _____ (name of account holder), the signature of the authorized signatory and the MICR and IFSC codes of our Branch mentioned above are correct.

PLACE:

DATE:

(Manager / Officer's
signature Under Bank stamp)

BHARAT HEAVY ELECTRICALS LIMITED
BOILER AUXILIARIES PLANT
RANIPET 632 406
GENERAL CONDITIONS OF CONTRACT FOR WORKS

SECTION -I

1. GENERAL INSTRUCTIONS TO TENDERERS

1.1. DESPATCH INSTRUCTIONS:

- 1.1.1.** This tender specification as a whole, duly furnishing all the details required and other documents as required in the following pages, shall be duly signed and sent in a sealed cover duly super scribing the name of work as given in the tender notice.
- 1.1.2.** The tender shall be addressed to Officer inviting tender as indicated in the tender notice.
- 1.1.3.** Tenders submitted by post shall be sent by “REGISTERED POST WITH ACKNOWLEDGEMENT DUE” and shall be posted with the due allowance for any postal delay. The tenders received after the due date and time of opening are liable to be rejected. Telegraphic offers and offers received by telex may not be considered.
- 1.1.4.** Tenders shall be opened by authorized officer of BHEL at his office at the time and date as specified in the tender notice in the presence of such of those bidders or their authorized representatives who may be present.
- 1.1.5.** The Tenders shall closely pursue all the clauses, specifications and drawings indicated in the tender documents before quoting. Should the bidder have any doubt the meanings of any portion of the tender specification or find discrepancies or omission in the drawings or the tender documents issued are in complete or shall require clarification on any of the technical aspect, scope of work etc., he shall at once contact the authority inviting the tender for clarification before the submission of the tender.
- 1.1.6.** Before tendering, the bidders are advised to inspect the site of work and the environments and be well acquainted with the actual working and other prevalent conditions, facilities available, position of material and labour. No claim will be entertained later, on the ground of lack of knowledge.
- 1.1.7.** Bidder must fill up all the schedules and furnish all the required information as per the instructions given in various sections of the tender specification. Each and every page of the Tender Specification must be signed and submitted along with the offers by the bidder in token of complete acceptance thereof . The information’s furnished shall be completed by itself.
- 1.1.8.** The bidders shall quote the rates in English language and international numerals. These rates shall be entered in figures as well as in words. In case of difference in rates between words and figures, the least of the two will be treated as valid rate. **In case of any discrepancy between the Unit rate quoted and the Total Price due to arithmetical errors, the Unit rate quoted will be considered valid and the Total price will be corrected accordingly.** For the purpose of the tender, the metric system of units shall be used.
- 1.1.9.** All entries in the tender shall either be typed or be written in ink. Erasers and overwriting are not permitted and may render such tenders liable to summary rejection. All cancellations and insertions shall be duly attested by the bidder.

1.2. QUALIFICATION OF BIDDERS:

Only bidders who have previous experience in the work of this nature and description detailed in this tender specification are expected to quote for this work duly submitting details of experience along with the offer. Offers from bidders who do not have proven and established experience in the field are not likely to be considered.

1.3. DATA TO BE ENCLOSED:

Full information shall be given by the bidder in respect of the following. Non-submission of these information may lead to rejection of the offer.

1.3.1. FINANCIAL STATUS:

A certificate from Scheduled Bank to prove his financial capacity to undertake the work duly indicating financial limits the bidder enjoys or solvency certificate from the concerned Government authority.

1.3.2. INCOME TAX CERTIFICATE:

A certificate of Income Tax clearance from the appropriate authority in the forms prescribed there for indicating annual turnover and the Sales Tax clearance certificate from the appropriate authorities as prescribed by the concerned state government, if any. These certificates shall be valid for one year from the date of issue or for the period prescribed therein for all tenders submitted during the period.

1.3.3. PREVIOUS EXPERIENCE:

A statement giving particulars duly supported by documentary evidence of the various services rendered for each similar work by the bidder indicating the particulars, value of each work, the site location, the duration, date of completion, a list of site locations and particulars and value of various services that are under progress. Information required in Annexure –BI & BII shall be furnished by the bidders along with the offer.

1.3.4. ORGANISATION CHART:

The Organization pattern that is presently available with the bidder and that will be employed by the bidder for this work shall be furnished.

1.3.5. An attested copy of the Power of Attorney, in case the tender is signed by an individual other than the sole proprietor, shall also be attached. (If it is a Company or Firm, etc., Director/Managing Partner as the case may be is required to sign)

1.3.6. IN CASE OF AN INDIVIDUAL:

His full name, address and place and nature of business shall be indicated.

1.3.7. IN CASE OF PARTNERSHIP FIRMS:

The names of all the partners and their addresses be furnished along with a copy of the partnership deed/instrument of partnership duly certified by Notary Public shall be enclosed.

1.3.8. IN CASE OF COMPANIES:

Date and place of registration including date of commencement certificate in case of public companies (certified copies of Memorandum and Articles of Association are also to be furnished) are to be furnished.

1.3.9. Nature of business carried on by the Company and the provisions of the Memorandum relating there of shall be furnished.

1.3.10 Names and particulars including addresses of the Directors and their previous experiences shall be furnished.

1.3.11 A list of tools and tackles that the bidder is having and those that will be used on this job shall be furnished.

1.3.12 In addition to the above, the particulars required in various annexure shall also be furnished.

1.4. EARNEST MONEY DEPOSIT:

1.4.1. Every tender must be accompanied by the prescribed amount of Earnest Money Deposit in any one of the following forms.

1.4.1.1. EMD shall be deposited in cash (as permissible under income tax act), Pay order or Demand Draft (payable at Ranipet in favour of "Bharat Heavy Electricals Ltd., ") only. No other form of EMD remittance shall be acceptable to BHEL.

1.4.1.2. In case of payment of EMD in the form of Cash, the amount should be remitted by the bidder to the Cash Office of Bharat Heavy Electricals Limited, BAP,Ranipet-632 406 during its working hours and cash receipt issued shall be enclosed along with the tender.

1.4.2. Tenders received without Earnest Money in full in the manner prescribed above are liable to be rejected.

1.4.3. The Earnest Money Deposit of the successful tenders may be retained towards part of Security Deposit.

1.4.4. In the case of unsuccessful bidders, the Earnest Money will be refunded to them within a reasonable time after finalization of the tender.

1.4.5. Earnest Money Deposit by the bidder will be forfeited as per tender documents if the bidder:

1.4.5.1. Fails to communicate unqualified acceptance of Letter of Intent within 15 days of date of Letter of Intent.

1.4.5.2. Does not commence the work within the period as per LOI/Contract. In case the LOI/Contract is silent in this regard then within fifteen days after award of contract.

1.4.5.3. After opening of Tender, revokes/withdraws his tender within the validity period or revises/alters his earlier quoted rates/conditions.

1.4.5.4. Fails to submit SD as indicated in the Letter of Intent.

1.4.6. Earnest Money deposit shall not carry any interest.

1.5. AUTHORISATION AND ATTESTATION:

1.5.1. Tenders shall be signed by persons duly authorized /empowered to do so. Certified copies of such authority and relevant documents shall be submitted along with the tenders.

1.6. VALIDITY OF OFFER:

The rates in the Tender shall be kept open for acceptance for a minimum period of three months from the date of opening of tenders. In case the Bharat Heavy Electricals Limited calls for negotiations such negotiations shall not amount to cancellation or withdrawal of the original offer, which shall be binding on the bidders.

1.7. EXECUTION OF CONTRACT:

The successful bidders responsibility under this contract commences from the date of issue of the Letter of Intent by Bharat Heavy Electricals Limited. The successful bidder shall be required to execute an agreement in the prescribed form (Annexure-D) with BHEL within a reasonable time after the acceptance of his tender and in any case before submitting the first bill for payment. The expenses for completion, stamping and registration of the agreement with prescribed authority, if necessary, shall be borne by the Contractor.

1.8. SECURITY DEPOSIT:

1.8.1. Upon acceptance of tender, the successful bidder within the time specified in the letter of intent must deposit the required amount of Security Deposit for satisfactory execution of work and shall not commence work under this contract before remitting security deposit except as directed by BHEL.

1.8.2. The total amount of Security Deposit shall be as follows:

1.8.2.1. In the case of work costing up to Rs.10 lakhs – 10% of the quoted value.

1.8.2.2. In the case of work costing Rs.10 lakhs to Rs.50 lakhs – Rs.1 lakh plus 7.5% of the amount exceeding Rs.10 Lakhs.

1.8.2.3. In the case of work costing more than Rs.50 Lakhs – Rs.4 lakhs plus 5% of the amount exceeding Rs.50 Lakhs.

1.8.3. The Security Deposit may be furnished in any one of the following forms:-

1.8.3.1. Cash (as permissible under the income tax act).

1.8.3.2. Pay order , Demand Draft in favour of BHEL.

1.8.3.3. Local cheques of Scheduled Banks, subject to realization.

1.8.3.4. Securities available from Post Offices such as National saving Certificates, Kisan Vikas Patras etc. (Certificates should be held in the name of contractor furnishing the security and duly pledged in favour of BHEL and discharged on the back).

1.8.3.5. Bank Guarantee from Scheduled Banks / Public Financial Institutions as defined in the companies act subject to a maximum of 50% of the total security deposit value. Balance 50% has to be remitted either by cash or in the other form of security. The Bank Guarantee format should have the approval of BHEL (Annexure-E). The Bank Guarantee furnished towards Security Deposit should be kept valid by proper renewal till the expiry of 6 Months after the said work is actually completed.

1.8.3.6. Fixed Deposit Receipt issued by Scheduled Banks / Public Financial Institutions as defined in the companies act. The FDR should be in the name of the contractor, account BHEL, duly discharged on the back.

1.8.3.7. Security deposit can also be recovered at the rate of 10% from the running bills. However in such cases at least 50% of the security deposit (as Bank Guarantee or Demand Draft) should be remitted before start of the work and balance 50% may be recovered from the running bills till the full Security Deposit is made up.

1.8.3.8. EMD of the successful bidder may be converted and adjusted against the security deposit on specific request by the contractor.

1.8.3.9. Acceptance of security deposit as per clause 1.8.3.4 and 1.8.3.6 above will be subject to hypothecation or endorsement on the documents in favour of BHEL. However, BHEL will not be liable or responsible in any manner for the collection of interest or renewal of the documents or in any other matter connected therewith.

1.8.4. If the value of the work done at any time exceeds the accepted agreement value, the security Deposit shall be correspondingly enhanced and the extra Security Deposit shall be immediately deposited by the Contractor or recovered from payments due to him.

1.8.5 Failure to deposit the Security Deposit within the stipulated time, may lead to forfeiture of Earnest Money and cancellation of the award of work.

1.8.6 If any part of Security Deposit of the Contractor is held in the form of approved securities it shall be kept transferred in the name of Bharat Heavy Electricals Limited, Ranipet, in such a manner that the same can be realized fully without referring to the Contractor, BHEL shall not be responsible for any depreciation in the value of the Security while in BHEL's custody or for

any loss of interest thereon.

1.8.7 BHEL reserves the right to forfeiture of Security Deposit in addition to the other claims and penalties in the event of the Contractor's failure to fulfill any of the Contractual obligation including liquidation or bankruptcy of the contractor, non-payment of money payable by means of arbitration award in favour of BHEL or in the event of termination of Contract as per terms and conditions of Contract. BHEL reserves the right to set off the Security Deposit, against any claims of any other contracts with BHEL.

1.8.8 RETURN OF SECURITY DEPOSIT:

If the Contractor performs and completes the work in all respects to the entire satisfaction of BHEL and presents an absolute "No Demand Certificate" in the prescribed form (Annexure-F) and returns properties belonging to BHEL handed over, lent or hired by him for carrying out the said works, Security Deposit will be released to the Contractor after deducting all cost of expenses or other amounts that are to be paid to BHEL under this or other contracts entered into with the Contractor. **It may be noted that in no case the Security Deposit shall be refunded/released prior to passing of final bill.**

1.9. REJECTION OF TENDER AND OTHER CONDITIONS

1.9.1. The acceptance of Tender will rest with BHEL which does not bind itself to accept the lowest tender or any tender and reserves to itself full rights for the following without assigning any reasons whatsoever.

1.9.1.1. To reject any or all of the bidders.

1.9.1.2. To split up the work amongst two or more Bidders.

1.9.1.3. To award the work in part.

1.9.1.4. Either of the contingencies stated in (1.9.1.2) and (1.9.1.3) above to modify the time for completion suitably.

1.9.2. Conditional and Unwitnessed tenders, tenders containing absurd or unworkable rates and amounts and tenders which are incomplete and otherwise considered defective and tenders not in accordance with the tender conditions, specifications, etc., are liable to be rejected.

1.9.3. If a bidder expires after the submission of his/her tender or after the acceptance of his/her tender, BHEL may at their discretion cancel such tender. If a partner of a firm expires the submission of the tender or after the acceptance of the tender, BHEL may cancel such tender at their discretion unless the firm retains its character.

1.9.4. BHEL will not be bound by any power of Attorney granted by the bidder or by changes in the composition of the firm made subsequent to the execution of the Contract. They may, however recognize such power of Attorney and changes after obtaining proper legal advice, the cost of which will be chargeable to the contractor concerned.

1.9.5. If the bidder deliberately gives wrong information in his tender, BHEL reserves the right to reject such tender at any stage or cancel the contract, if awarded. The Earnest Money/Security Deposit /any other money due shall also be forfeited.

1.9.6. Canvassing in any form in connection with the tender is strictly prohibited and the tenders submitted by the contractor's who resort to canvassing in any form are liable to rejection.

1.9.7. Should a bidder or contractor or in the case of a firm or company of contractor's one or more of its partners/share holders/Directors have a relation or relations employed in BHEL, the authority inviting tender shall be informed of the fact along with the offer, failing this BHEL may, at its sole discretion reject the tender or cancel the contract and forfeit the Earnest Money/Security Deposit.

1.9.8. The successful bidder should not sub-contract the part or complete work detailed in the tender specification undertaken by him without written permission of BHEL. The bidder is

solely responsible to BHEL for the work awarded to him.

1.9.9. No deviation from the tender specification shall be acceptable to BHEL. Bidders shall confirm their unqualified acceptance of the terms and conditions by giving an undertaking to this effect in a separate letter as specified by BHEL.

1.10. NO INTEREST shall be payable by BHEL on Earnest Money / Security Deposit / or any money due to the Contractor by BHEL.

1.11. COMPLIANCE TO REGULATIONS AND BY-LAWS

The Contractor shall conform to the provisions of any statute relating to the work and regulations and Byelaws of any local authority. The Contractor shall be bound to give all notices required by statute regulations or By-Laws as aforesaid and to pay all fees and taxes payable to any authority in respect thereof.

a) Minimum Wages for the workers engaged for this work:

The Contractor shall remain liable for the payment of all wages or other moneys to his workmen or employees under the payment of Wages Act 1936, Employees Liability Act. 1938, Workmen's Compensation Act 1923 or any other Act or enactment, relating thereto and rules framed, there under from time to time.

The current minimum wages for skilled worker is Rs 203.00 / day, semi skilled worker is Rs 197.00 / day and for un skilled worker it is Rs. 190.00 / day. The contractor shall ensure to pay wages not less than this minimum wage to the workers deployed by him in this work along with other statutory payments. Any increase in wages during currency of the contract also to be paid by the contractor within the quoted rates.

1.12 PAYMENT TERMS.

- 1) 90 % of the scheduled rates shall be paid after completion of erection/wiring.
- 2) Further 5% for the above schedules will be paid after testing and commissioning of individual schedule items.
- 3) Final 5% for the above schedules shall be paid after the guarantee period of 6 months from the date of commissioning/energizing or against submission of BG valid for 6 months.

All payments to be made to the Contractor, under this contract shall be by " NEFT " (National Electronic Fund Transfer) / " RTGS " (Real Time Gross Settlement) within a reasonable time say one month after the certification of bills by the SM/M&S or any official of M&S department authorized by him for this purpose.

1.13 Guarantee Period

Six months from the date of actual completion of the entire work and handed over to Bharat Heavy Electricals Limited)

SECTION -II

2.1. DEFINITION:

The following terms shall have the meaning hereby assigned to them except where the context otherwise requires.

- 2.1.1. BHEL or (B.H.E.Ltd)** shall mean Bharat Heavy Electricals Limited a Company registered under Indian Companies Act 1956, with its Registered Office at BHEL House, Siri fort, New Delhi 110 049 or its Authorized Officers or its Resident Engineer or other employees authorized to deal with any matters with which these persons are concerned on its behalf.
- 2.1.2. “GENERAL MANAGER”**
Shall mean the Officer in Administrative charges of contracting unit of BHEL.
- 2.1.3. “ENGINEER” or “ENGINEER IN CHARGE”** shall mean Engineer who is in-charge for the works referred.
- 2.1.4. “SITE”** shall mean the place or places at which the plants/equipments are to be erected and services are to be performed as per the specification of this contract.
- 2.1.5. “CONTRACTOR”** shall mean the individual, firm or company who enters in to this contract with BHEL and shall include their executors, administrators, successor and permitted assignees.
- 2.1.6. “CONTRACT” or “CONTRACT DOCUMENT”** shall mean/and include the agreement or work order, the accepted appendices of rates, schedules, quantities, if any and general conditions of contract, the special conditions of contract, instructions to the bidders, the drawings, the technical specifications, the special specifications, if any, the tender documents and the Letter of Intent/Acceptance Letter issued by BHEL. Any conditions or terms stipulated by the contractor in the tender document or subsequent letters shall not form part of the contract unless specially accepted in writing by BHEL, in the Letter of intent and incorporated in the agreement.
- 2.1.7. “GENERAL AND SPECIAL CONDITIONS OF CONTRACT”** shall mean the “Instructions to Bidders and General and Special Conditions of Contract” pertaining to the work for which the bidders are called for.
- 2.1.8. “TENDER SPECIFICATIONS”** shall mean the “SPECIFIC CONDITIONS, Technical specifications, appendices, site information’s and drawings” pertaining to the work in which the bidders are required to submit their offer, Individual specification number will be assigned to each tender specification..
- 2.1.9. “TENDER DOCUMENTS”** shall mean the General and Special Conditions of Contract (2.1.7) and tender specification(2.1.8).
- 2.1.10. “LETTER OF INTENT”** shall mean the intimation by a letter to the bidder that the tender has been accepted in accordance with provisions contained in that letter. The responsibility of the contractor commences from the date of issue of this letter and all the terms and conditions of contract are applicable from this date.
- 2.1.11. “COMPLETION TIME”** Shall mean the period by date specified in the acceptance of tender or date mutually agreed upon for handing over of the erected equipment/plant which are found acceptable by the Engineer being of required standard and conforming to the specifications of the contract.

- 2.1.13. "PLANT"** shall mean and cannot the entire assembly of the plant and equipments covered by the contract.
- 2.1.14. "EQUIPMENT"** shall mean all equipments, machinery, materials, structurals, electricals and other components of the plant covered by the contract.
- 2.1.15. "TESTS"** shall mean and include such test or tests to be carried out on the part of the contractor as are prescribed in the contract or considered necessary by BHEL in order to ascertain the quality, workmanship, performance and efficiency of the contract work or part thereof.
- 2.1.16. "APPROVED" "DIRECTED" or "INSTRUCTED"** shall mean approved, directed or instructed by BHEL.
- 2.1.17. "WORK OR CONTRACT WORK"** shall mean and include supply of all categories of labour specified consumables, tools and tackles required for complete and satisfactory site transportation handling, stocking, storing, erecting, testing, and commissioning of the equipments to the entire satisfaction of BHEL.
- 2.1.18. "SINGULAR AND PLURAL ETC"** works carrying singular number shall also include plural and vice versa, where the context so required. Words importing the masculine gender shall be taken to include the feminine gender and words imparting persons shall include any company or association or body of individuals, whether incorporated or not.
- 2.1.19. "HEADINGS"**
- The headings in these general conditions are solely for the purpose of facilitating reference and shall not be deemed to be part thereof or be taken into consideration in the interpretation or construction thereof or of the contract.
- 2.1.20. "MONTH"** shall mean calendar month, unless specified otherwise in the tender.
- 2.1.21. "WRITING"** shall include any manuscript typewritten or printed statement under the signature of BHEL.

2.2. LAW GOVERNING THE CONTRACT AND COURT JURISDICTION

The contract shall be governed by the Law for the time being in force in the Republic of India, and shall be subject to the Jurisdiction of the courts having Jurisdiction over RANIPET (VELLORE Dist, Tamil Nadu).

2.3. ISSUE OF NOTICE:

The Contractor shall furnish to the BHEL ENGINEER the name, designation and address of his authorized agent and all complaints, notices, communication and reference shall be deemed to have been duly given to the contractor or his authorized agent or left or posted to the address of either the contractor or of his representative and shall be deemed to have been so give in the case of posting on the day on which they would have reached such address in the ordinary course of post or on which they were so delivered of / or left.

2.4. USE OF LAND:

No land belonging to BHEL or their customer under temporary possession of BHEL shall be occupied by the Contractor without the written permission of BHEL.

2.5. COMMENCEMENT OF WORKS:

- 2.5.1.** The Contractor shall commence the works within the time indicated in the Letter of Intent from BHEL and shall proceed with the same with due expedition without delay.

- 2.5.2.** If the successful bidder fails to start the work within the stipulated time, BHEL, at his sole discretion will have the right to cancel the contract. His earnest money and/or Security Deposit with BHEL will stand forfeited without any further reference to him without prejudice to any and all of BHELs other rights and remedies in this regard.
- 2.5.3.** All the works shall be carried out under the direction and to the satisfaction of BHEL.
- 2.5.4.** The erected/constructed plant or work performed under this contract shall be taken over when it has been completed in all respects and/or satisfactorily put in to operation at site.
- 2.6. MODE OF PAYMENT AND MEASUREMENT OF THE WORK COMPLETED:**
- 2.6.1.** All payments due to the contract shall be paid through E-PAYMENT (EFT / RTGS) only. The contractor has to furnish acceptance for e-payment, duly indicating the bank account details in the prescribed format.
- 2.6.2.** For Progress running bill payment:

The contractor shall present detailed measurement working sheets, in quadruplicate, duly indicating all relevant details based on technical documents and connected drawings for work done during the month/period under various categories in line with terms of payment as per letter of intent. The basis of arriving at the quantities/weight shall be the relevant documents and drawings released by BHEL.
- 2.6.3.** These measurement working sheets will be checked and vetted by BHEL Engineers and quantities and percentage eligible for payment under various groups shall be decided by BHEL engineers. The abstract of quantities and percentage so arrived based on the terms of payment shall be entered in Measurement Book and signed by both the parties.
- 2.6.4.** Based on the above quantity, contractor shall prepare the bills in prescribed proforma and work out the financial value. These will be entered in Measurement Book and signed by both the parties and paid duly effecting recoveries due.
- 2.6.5.** All recoveries due from the contractor for the month/period shall be effected in full from the corresponding running bills unless specific approval from the competent authorities is obtained otherwise.
- 2.6.6.** Measurement shall be restricted to that for which it is required to ascertain the financial liability of BHEL under this contract.
- 2.6.7.** The measurement shall be taken jointly by persons duly authorized on the part of BHEL and by the contractor.
- 2.6.8.** The contractor shall bear the expenditure involved, if any, in making the measurement. The contractor shall, without extra charges provide all the assistance with appliances and other things necessary for measurement.
- 2.6.9.** If, at any time due to any reason, whatsoever, it becomes necessary to re-measure the work done in full or in part, the expenses towards such re-measurements shall be borne by the contractor.
- 2.6.10.** Passing of measurement as per bills does not amount to acceptance of the completion of the work mentioned. Any left out work has to be completed if pointed out at a later date by BHEL.
- 2.6.11.** Final measurement bill shall be prepared in the final bill proforma prescribed for the purpose based on the certificate issued by BHEL Engineer that entire work as stipulated in the tender specification has been completed in all respects to the entire satisfaction of BHEL. Contractor's shall give unqualified „No Due“ and „No Demand“ certificate. All the tools and tackles loaned to them should be returned in condition satisfactory to BHEL. Quantities/Weight erected shall be prepared and paid, within a reasonable time after completion of work. After payment of final bill, only guarantee obligation percentage shall remain unpaid which shall be released in accordance with clause 2.13. The final bill quantities and financial value shall also be entered in Measurement Book and signed by both the parties to the contract.

2.7 RIGHTS OF BHEL

BHEL reserves the following rights in respect of this contract without entitling the contractor for any compensation.

- 2.7.1.** To get the work done through other agency at the risk and cost of the Contractor, in the event of Contractor's poor progress, or inability to progress the work, persistent disregard in instruction of BHEL, assignment transfer, subletting of the contract without permission of BHEL, non fulfillment of any contractual obligation etc., and to recover compensation for such losses from the contractor including BHELs supervision charges and overheads from Security Deposit / other dues.
- 2.7.2.** To withdraw any portion of work and/or to restrict/alter quantum of work as indicated and get it done through other agency and/or with departmental labour to suit BHEL's commitment to its customer or in case BHEL decides to advance the date of completion due to other emergency reasons/BHELs obligation to its customer.
- 2.7.3.** To terminate the contract after due notice to cause forfeiting of Security Deposit and recover the loss sustained in getting the balance work done through other agencies in addition to liquidated damages in the event of :
 - 1)** Contractor's continued poor progress.
 - 2)** Withdrawal from or abandonment of the work before completion of the work.
 - 3)** Corrupt act of contractor.
 - 4)** Insolvency of the contractor.
 - 5)** Persistent disregards to the instructions of BHEL.
 - 6)** Assignment transfer, sub-letting of the contract without BHEL's permission.
 - 7)** Non-fulfillment of any contractual obligations.
- 2.7.4.** To recover any money due from the contractor from any money due to the contractor under this contract or any other contract or from the Security Deposit.
- 2.7.5.** To claim compensation for losses sustained including BHEL's supervision charges and overheads for completion on termination of contract and to impose penalty for delay in completion of the work at the rate of ½% of the contract value per week of delay or part thereof subject to a ceiling of 10% of contract value.
- 2.7.6.** To terminate the contract or to restrict the quantum of work and pay for the portion of work executed in case BHEL's contracts with their customers are terminated for any reason.
- 2.7.7.** To effect recovery from any amount due to the contractor under this or any other contractor in any other form the moneys BHEL is forced to pay to anybody, due to contractor's failure to fulfill any of his obligation.
- 2.7.8.** To restrict or increase the quantity and nature of work to suit the site requirements since the tender specification is based on preliminary documents and quantities furnished there in are indicative and approximate and the rates quoted shall not be subject to revision.
- 2.7.9.** To deploy BHEL's fitters, welders, operators and technicians in case of emergency/poor progress/deficiency in skill on the part of employees of contractor and to recover the expenditure on account of the same from contractor's bills.
- 2.7.10.** While every endeavor will be made by BHEL they cannot guarantee un-interrupted work to the contractor due to conditions beyond their control. Contractor will not be entitled for any compensation extra payment on his account.

2.7.11. In the event of any dispute of any nature, the decision of BHEL shall be final and binding on the contractor.

2.8. RESPONSIBILITIES OF THE CONTRACTOR IN RESPECT OF LOCAL LAWS, EMPLOYMENT OF WORKERS Etc.

The following are the responsibilities of the Contractor in respect of observation of local laws, employment of personnel, payment of taxes etc.

2.8.1. As far as possible unskilled workers shall be engaged from the local areas in which the work is being executed.

2.8.2. The contractor at all times during the continuance of this contract shall, in all his dealings with local labour for the time being employed on or in connection with the work, have due regard to all local festivals, religious and other customs.

2.8.3. The contractor shall comply with all state and Central Laws, Statutory Rules, Regulations etc., inclusive of those regarding labour and industrial laws which are applicable from time to time and they shall comply with the provisions of the said labour legislations, rules and regulations framed under the provisions of Employees Provident Fund and Miscellaneous Provisions Act 1952 shall be strictly followed.

2.8.4. The contractor shall pay all taxes, including sales Tax on works contract if any fees, license, charges, deposits duties, tool royalty commissions or other charges which may be leviable on account of any of his operations in execution of the contract in case BHEL is forced to pay any of such taxes. BHEL shall have the right to recover the same from the contractor either from his bills or other wise as deemed fit.

2.8.5. While BHEL would pay the inspection fees, of the Boiler Inspectorate, all other arrangements for the visits periodically by Boiler Inspector to site, Inspection Certificate etc., will have to be made by the contractor. However BHEL will not make any payment to Boiler Inspector in connection with contractor's welder's qualification/requalification tests etc.

2.8.6. The contractor shall be responsible for provision of health and sanitary arrangements (more particularly described in Contract Labour Regulation & Abolition Act) safety precautions etc., as may be required for safe and satisfactory execution of the contract.

2.8.7. The contractor shall be responsible for providing proper accommodation including adequate medical facilities for the personnel employed by him.

2.8.8. The contractor shall be responsible for the proper behavior and observance of all regulations by the staff employed by him.

2.8.9. The contractor shall ensure that no damage is caused to any person/property of other parties working at site. If any such damage is caused it is the responsibility of the contractor to make good the losses or compensate for the same.

2.8.10. All the properties/equipments/components of BHEL their client loaned with or without deposit to the contractor in connection with contract shall remain the properties of BHEL/their client. The contractor shall use such properties for purpose of execution of this contract, all such properties/equipments/components shall be deemed to be in good condition when received by the Contractor's unless he notifies within 48 hours to the contrary. The Contractor shall return them in good condition as and when required by BHEL/their client. In case of non-return, loss, damage, repairs etc, the cost thereof, as may be fixed by the site Engineer, will be recovered from the Contractor.

2.8.11. It is not obligatory on the part of BHEL to supply any tools and tackles or other materials other than those specifically agreed to do so by BHEL. However, depending upon the availability/possibility BHEL's customer's handing equipment and other plants may be made available to the contractor on payment of the hire charges/free of charges, as fixed subject to the conditions laid down by BHEL/Customer from time to time. Unless paid in advance such

hire charges if applicable shall be recovered from contractor's bills/security deposit in one installment.

- 2.8.12.** The Contractor shall fully indemnify BHEL against all claims of whatsoever nature arising during the course of erection/construction/performing work under the contract.
- 2.8.13.** In case the Contractor is required to undertake any work outside the scope of this contract the rate payable shall be those mutually agreed upon.
- 2.8.14.** Any delay in completion of works/non-achievement of periodical targets, due to reasons attributable to the contractor, the same will have to be compensated by the Contractor either by increasing manpower and resources or by working extra hours and/or by working more than one shift. All these are to be carried out by the contractor at no extra cost.
- 2.8.15.** The contractor shall arrange and co-ordinate his work in such a manner as to cause no hindrance to other agencies working in the same premises.
- 2.8.16.** All safety rules and codes applied by the client/BHEL at site shall be observed by the contractor without exception. The contractor shall be responsible for the safety of the equipment/material and works to be performed by him and shall maintain all light, fencing guards signs etc, or other protection necessary for the purpose. Contractor shall also take such additional precautions as may be indicated from time to time by the Engineer with a view prevent pilferage, accidents, fire hazards and due precautions shall be taken against fire hazards and atmospheric conditions. Suitable number of clerical staff, watch and ward, store keepers to take care of equipment, materials and construction tools and tackles shall be posted at site by the contractor till the completion of the work under this contract. The contractor shall arrange for such safety devices as are necessary for such type of work and carry out the requisite site tests of handling equipments, lifting tools, tackles, etc., as per prescribed standards and practices.
- 2.8.17.** The contractor will be directly responsible for payment of wages to his workmen. A pay roll sheet giving all the type payments given to the workers and duly signed by the contractor's representative should be furnished to BHEL Site office on or before 15th of every succeeding month.
- 2.8.18.** In case of any class of work for which there is no such specification as laid down in the contract, such work shall be carried out in accordance with the instructions and requirements of the Engineer.
- 2.8.19.** No levy of payment or charge made or imposed shall be impeached by reason of any clerical error or by reason of any mistake in the amount levied or demanded or charged.
- 2.8.20.** Also no idle labour charges will be admissible in the event of any stoppage caused in the work resulting contractor's labour being rendered idle due to any cause at any time.
- 2.8.21.** The contractor shall take all reasonable care to protect the materials and work till such time the plant/equipment has been taken over by BHEL/their client.
- 2.8.22.** Contractor shall not stop the work or abandon the site for whatsoever reason or dispute, excepting for force major conditions. All such problems/dispute, shall be separately discussed and settled without affecting the progress of work. Such stoppage or abandonment shall be treated as breach of contract and dealt with accordingly.

2.9. CONSEQUENCES OF CANCELLATION:

Whenever BHEL exercises its authority to terminate the contract/withdraw a portion of work under the clause 2.7 they may complete the work by any means. In the event of the cost of completion as certified by the site Engineer which is final and conclusive being less than the contract cost, the advantage shall accrue to BHEL and that if the cost of completion exceeds the moneys due to the contractor under the contract, the contractor shall either pay the excess amount ordered by BHEL or the same shall be recovered from the contractor by any other means. This will be in addition to the forfeiture of Security Deposit and recovery of liquidated damages as per the relevant clauses.

2.9.1. In case BHEL completes the work under the provision of this condition, the cost of such completion to be taken into account in determining the excess cost to be charged to the contract under this condition, shall consist of materials purchased and/or labour provided by BHEL with an addition of such percentage to cover supervision and establishment charges as may be decided by BHEL.

2.10 INSURANCE:

2.10.1. BHEL/their customer shall arrange for insuring the materials/properties of BHEL / customer covering the risks during transit, storage, erection and commissioning.

2.10.2. It is sole responsibility of the contractor to insure his workmen against accidents and injury while at work as required by relevant Rules and to pay compensation, if any, to workmen as per workmens Compensation Act. The work will be carried out in a protected area and all the rules and regulations of the client/BHEL in the area of project which are in force from time to time will have to be followed by contractor.

2.10.3. If due to negligence and/or non-observance of safety and other precautions, any accident/injury occurs to any other persons/public, the contractor shall have to pay necessary compensation and other expenses if so decided by the appropriate authorities.

2.10.4. If due to contractor's carelessness, negligence of non-observance of safety precautions damage to BHELs /customers property and personnel should occur and if BHEL is unable to recover in full cost from the insurance company, the same will be recovered from the contractor.

2.10.5. It shall be the responsibility of the contractor to provide security arrangement for the equipment/ materials belonging to BHEL and handed over to the contractor for erection/transportation till the same are taken over by BHEL after erection/returned to BHEL stores.

2.11. STRIKES & LOCKOUTS:

2.11.1. The contractor will be fully responsible for the entire dispute and other issues connected with his labour. In the event of the contract labour resorting to strike or the contract resorting to lock-out and if the strike or lock-out declared is not settled within a period of one month, BHEL, shall have the right to get the erection work executed employing its won labour or through any agencies or both and the cost so incurred by BHEL be deducted from the contractor's bills.

2.11.2. For any purpose whatsoever the employees of the contractor shall not be deemed to be in the employment of BHEL.

2.12. FORCE MAJEURE:

2.12.1 The following shall amount to FORCE MAJEURE:

Act of God or of any Government, War, Sabotage, Riots, Civil commotion, Police action revolution, Flood, Fire, Cyclones, Earth quake and epidemic and other similar causes over which the contractor has no control.

2.12.2. If the contractor suffers delay in the due execution of the contractual obligation due to delays caused by FORCE MAJEURE as defined above, the agreed time of completion of the job covered by this contract or the obligation of contractor shall be extended by a period of time equal to the period of delay provided that on the occurrence of any such contingency the contractor immediately reports to BHEL in writing the causes of delay and the contractor shall not be eligible for any compensation.

2.13. GUARANTEE:

Even though the work will be carried out under the supervision of BHEL Engineers the contractor will be responsible for the quality of the workmanship and shall guarantee the work done for a period of six months from the date of completion of work as certified by the Engineer for good workmanship and shall rectify free of cost all defects due to faulty erection, detected during the guarantee period starting from the date of the completion of rectification. In the event of the contractor failing to repair the defective works within the time specified by the Engineer, BHEL may proceed to undertake the repairs of such defective works at the contractor's risk and cost, without prejudice to any other rights and recover the same from Security Deposit/other dues or by other legal means

2.14. ARBITRATION:

Except where otherwise provided for in the contract all questions and disputes relating to the meaning of the specifications, designs, drawings and instructions herein before mentioned and as to the quality of workmanship or materials used on the work or as to any other question, claim, right, matter or thing whatsoever in anyway arising out of or relating to the contract, designs, drawings, specifications, estimates, instructions, orders or these conditions or otherwise concerning the work or failure to execute the same whether arising during the progress of the work or after the completion or abandonment thereof shall be referred to the sole arbitration of the General Manager of BHEL and if General Manager is unable or unwilling to act, to the sole arbitration of some other person appointed by the General Manager, willing to act as such arbitrator.

The cases referred to arbitration shall be other than those for which the decision of the Accepting

Officer, or Engineer-in-charge as the case may be is expressed in the contract to be final and conclusive. There will be no objection if the arbitrator so appointed is an employee of BHEL and that he had to deal with the matters to which the contract relates and that in the course of his duties as such he had expressed views on all or any of the matters in dispute or difference.

The arbitrator to whom the matter is originally referred being transferred or vacating his office or being unable to act for any reason, such General Manager as aforesaid at the time of such transfer, vacation of office or inability to act shall appoint another person to act as an arbitrator in accordance with the terms of the contract. Such person shall be entitled to proceed with the reference from the stage at which it was left by his predecessor.

Subject as aforesaid the provision of the Arbitration Act 1940 or any statutory modification or reenactment thereof and the rules made there under and for the time being in force shall apply to the arbitration proceeding under this clause.

It is a term of the contract that the party involving arbitration shall specify the dispute or dispute to be referred to arbitration under this clause together with the amount or amounts claimed in respect of each such dispute.

The arbitrator(s) may from time to time with consent of the parties enlarge the time, for making and publishing the award.

The work under the contractor shall, if reasonably possible, continue, during the arbitration proceedings and no payment due or payable to the contractor shall be withheld on account of such proceedings.

The arbitrator shall be deemed to have entered on the reference on the date he issues notice to both the parties fixing the date of first hearing.

The arbitrator shall give a separate award in respect of each dispute or difference referred to him.

The venue of arbitration shall be such place as may be fixed by the Arbitrator in his sole discretion. The award of the Arbitrator shall be final conclusive and binding on all parties to this contracts.

In the event of disputes or differences arising between one public sector and a Government Department or between two public sector enterprises the above stipulations shall not apply, the provisions of BPE Office memorandum No.BPE/CL/001/76 MAN/2(1.10)76-BPE(GM-1)dated 1st January 1976 or its amendments for arbitration shall be applicable.

ANNEXURE – “D”

**BHARAT HEAVY ELECTRICALS LIMITED (A
GOVERNMENT OF INDIA UNDERTAKING)
BOILER AUXILIARIES PLANT
INDIRA GANDHI INDUSTRIAL COMPLEX
M & S DEPARTMENT
RANIPET – 632 406**

CONTRACT AGREEMENT

AGREEMENT NO: BAP : ERN : BHE :

DATE:

Name of work :

Name of the contractor with full address :

Amount of tender accepted :

Letter of Intent No. :

Time allotted for completing the work
(date of completion) :

CONTRACTOR

(Officer authorized to sign the agreement)

**SIGNATURE OF THE BIDDER
WITH SEAL AND ADDRESS**

CONTRACT AGREEMENT

AGREEMENT No: BAP: ERN : BHE :

DATE:

This agreement made this day, the _____ of _____ between the Bharat Heavy Electricals Limited, Ranipet having its Registered Office at „BHEL House“ , Siri Fort, New Delhi 110 049 (herein after called the FIRST PARTY) of one part and Messrs. _____ (herein after called the (“CONTRACTOR”) of the SECOND PARTY.

2. WHEREAS the first party is desirous of executing the work of more particularly described in the appendices including drawings and specifications attached herewith.

3. WHEREAS IN PURSUANCE of the said Contractor’s Tender having been accepted, the first party has decided to give the above said work to Contractor, and WHEREAS the contract between the parties was concluded by virtue of a letter of intent issued by the First Party under reference. Dt.

4. WHEREAS the said Contractor has agreed to do the aforesaid work of the first party subject to the conditions herein contained in the presents, instructions to bidders general conditions and special conditions, schedules, appendices, letter of intent and specifications (hereinafter referred as the said contract schedule) at the approved rates (herein referred as the said contract rate).

5. AND WHEREAS the said contractor has furnished a Bank Guarantee for a sum of Rs. _____ Valid up to _____ towards initial 50% security Deposit and has further agreed for balance 50% Security Deposit being recovered at 10% of value of each running bill till the full Security Deposit is made up for the satisfactory completion and performance of the work and whereas the validity of the said Bank Guarantee has to be extended by the Contractor, if so required before for the balance period of contract period and in the event of his failure to do so, the contractor shall pay or accept recovery of this amount of Rs. _____ (Rupees _____ only), from the bills forthwith in one installment and it has further been agreed that the failure to extend the validity of Bank Guarantee or failure to pay the aforesaid amount the manner specified above shall constitute the breach of contract, and first party reserved the right to take easy legal action deemed fit for recovering the said sum of Rs. _____ (Rupees _____ only). This amount of Rs. _____ Will be refunded (and Bank Guarantee will be returned) to the Contractor on satisfactory completion of the work as specified in the Contract documents.

6. Now THESE PRESENTS WITNESS that in consideration of the said contract schedule and said contract rate as also of agreement of good and faithful services to be rendered and performed by the contractor in the execution of the said work, subject to the stipulation hereinafter expressed.

7. That the said contractor will perform the aforesaid work subject to the conditions contained in these presents, instructions to bidder, general and special conditions of contract and the contract documents attached herewith including the said schedules, specifications, appendices, letter of intent, drawings attached and also such other drawings and instructions as may from time to time be given by the first party. And that the said contractor shall be deemed to have carefully examined the specifications and conditions of contract, appendices, schedules, letter of intent , drawings etc., as aforesaid and also to have satisfied himself as to the nature and character of work to be executed.

**SIGNATURE OF THE BIDDER
WITH SEAL AND ADDRESS**

8. That the said contractor shall carry out and complete the execution of the said work to the entire satisfaction of the Engineer within the agreed time schedule.

9. That the first party after proper scrutiny of the bills submitted by the said contractor will pay to him during progress of the said work, at said contract rates and agreed terms of payment, a sum as determined by the first party in respect of the work executed by the contractor.

10. That the contract shall come into force with retrospective effect from the date on which the letter accepting the tender (Letter of Intent) has been issued to the said contractor.

11. That whatever under this contract or otherwise, any sum of money shall be recoverable from or payable by the Contractor, the same may be deducted in the manner as set out in the conditions of contract as aforesaid.

12. That all charges on account of Octroi, terminal and sales-tax or other duties on materials obtained for the work shall be borne by the said contractor.

13. That is agreed between the parties that the non-exercise of any of the powers conferred on the authorities of the first party will not in any manner constitute waiver of the conditions thereto contained in these presents and the liability of the said contractor either of past or further compensation shall remain unaffected.

14. That the expression BHEL wherever occurring means THE BHARAT HEAVY ELECTRICALS LIMITED, RANIPET.

15. The contract is subject to RANIPET (TamilNadu) jurisdiction.

16. The document hereto attached viz. shall also form part of this agreement.

17. General Conditions of Contract attached to the Notice inviting tender shall form part of this contract in so far as any thing is not provided specifically in this agreement.

18. In witness hereof the parties have respectively set their signatures in the presence of :

WITNESSES:

(with full address)

1.

2.

**Signature of the Contractor (to be signed by a
Person holding valid power of Attorney of the Company)**

Date:

WITNESSES:

(with full address)

1.

2.

For and on behalf Bharat Heavy Elec.Ltd.

Date:

**SIGNATURE OF THE BIDDER
WITH SEAL AND ADDRESS**

ANNEXURE "E"

PROFORMA FOR SECURITY DEPOSIT

THIS DEED OF GUARANTEE made this day of _____ by Messrs. _____ (hereinafter called the Bank) in favour of Messrs. BHARAT HEAVY ELECTRICALS LIMITED, RANIPET having its Registered Office at New Delhi (hereinafter called the Principal)

WHEREAS Messrs. _____ (hereinafter called the Contractor) has entered in to a Contract with Bharat Heavy Electricals Ltd., Ranipet arising out of Letter of Intent No. _____ Dt. _____ addressed by the Principal to the Contractor (hereinafter called the said agreement) for

AND WHEREAS the said Agreement provides that the contractor shall pay a sum of Rs. _____ (Rupees _____ only) towards 50% of full Security Deposit to be made in the form and manner therein specified.

AND WHEREAS the Contractor have approached the Bank and at their request and in consideration of the agreement arrived at between the said contractor and the Bank, the Bank has agreed to give such guarantee as hereinafter mentioned to the Principal.

NOW, therefore, these present witness those we the Bank by the hand Mr. _____ its lawfully and duly constituted attorney, do hereby undertake to pay to the principal a sum of Rs. _____ (Rupees _____ only) without demur on demand being made by the principal and to keep the principal indemnified to the extent of Rs. _____ by virtue of this guarantee against any loss or damage caused to or suffered by the principal by reason of any breach by the aforesaid contract of any of the terms and or conditions, stipulations or undertakings of any one of them contained in the said Agreement and the tender documents attached thereto and for the payment of any money or moneys payable by the said contractor to the principal under the terms and conditions of the said Agreements (the decisions regarding the breach, loss damage or payment due being solely in the discretion of the Principal).

We further undertake to pay without demur the aforesaid amount in a lump sum on demand or such part thereof as the Principal may demand from time to time irrespective of the fact whether the said contractor admits or denies such claim or questions its correctness in any Court Tribunal or Arbitration Proceedings or before any authority. The aforesaid guarantee will remain in force and we shall be liable under the same irrespective of any concession or time being granted by the principal, to the Contractor in or fulfilling the said agreement between contractor and the principal and the guarantee will remain in full force irrespective of any change of terms, conditions or stipulation or any variation in the terms of the said agreement irrespective of whether notice of such change or/variation is given to us or not and claim to receive such notice of any change/and or variation of the terms and or variation of the terms and or/conditions of the said agreement is hereby specifically waived by us. Further we shall not be release from this guarantee by any forbearance of the exercise or non-exercise of any of the powers or rights under the said agreement by the principal against the contractor irrespective of whether notice of such forbearance enforcement or non-enforcement of any powers or rights, modifications or change made in the said agreement or concessions shown to contractor by the principal is given to us or not.

The guarantee herein contained shall not be determined or affected by the liquidation or winding up or insolvency of or change in the constitution of the contractor but shall in all respects and for all purposes be binding and operative until all payments of all moneys due or that may hereafter become due to the principal in respect of any liability or obligations of the contractor under the said agreement.

**SIGNATURE OF THE BIDDER
WITH SEAL AND ADDRESS**

We, the Bank further agree that the guarantee herein contained shall remain in full force and effect during the period that would be taken for the performance of the said agreement and that it shall continue to be enforceable till all the dues of the principal under or by virtue of the said agreement have been fully paid and its claims satisfied or discharged or till the principal certifies that the terms and conditions of the said Agreement have been fully and properly carried out by the said contractor and accordingly discharges the guarantee subject to however that the principal I shall have no rights under this guarantee after the expiry of six months from the date of completion of the contract (the date of completion shall be as certified by the Principal) unless this guarantee is extended by agreement.

Any claim or dispute arising under the terms of this contract shall only be enforced or settled in the Court having jurisdiction over RANIPET (VELLORE Dist, Tamil Nadu)

And lastly the Bank undertakes not to revoke this guarantee during its currency except with the previous consent of the principal in writing.

The bank hereby declares that it has power to issue this guarantee under that Bank's Memorandum and Articles of Association and the undersigned has power to do so on its behalf under the power of Attorney granted to him by the proper Authorities of the Bank.

Date:

(Name of the Bank & Place)

Seal:

***DESIGNATION OF THE AUTHORISED
PERSON SIGNING THE GUARANTEE***

**SIGNATURE OF THE BIDDER
WITH SEAL AND ADDRESS**

ANNEXURE 'F'

NO DEMAND CERTIFICATE

1) Name of work :

2) Agreement date :

3) I/We certify that

- a) I/We have completed the above work to the entire satisfaction of BHEL
- b) I/We have handed over all the balance materials, components, tools and tackles, machinery and other equipment of BHEL
- c) C) I/We have received the final payment from BHEL for the above work.
- d) I/We have no further demand whatsoever from BHEL

I/We, therefore request you to refund to me / us the security deposit of Rs.

(Rupees..... only) and the bank guarantee No.: dt.for
Rs. After deducting all cost of expenses or other amounts that are to be paid by me/us
to BHEL under this contract or other contract entered in to by me / us with BHEL.

Signature of the Contractor with Seal

Place :

Date :

Witness 1)

2)

3)

**SIGNATURE OF THE BIDDER
WITH SEAL AND ADDRESS**

SPECIAL INSTRUCTIONS TO BIDDRES

1. Sealed Tenders for the work mentioned in the Schedule are invited from Contractors experienced in works of similar kind and magnitude.
2. Tenders must be submitted in **sealed covers** and should be addressed to

**MANAGER / ELECTRICAL
CIVILTOWNSHIP DEPARTMENT
BHARAT HEAVY ELECTRICALS LIMITED
BOILER AUXILIARIES PLANT
RANIPET – 632 406, VELLORE DISTRICT
TAMIL NADU**

The Name, Address of the Bidder and the name of work shall be clearly mentioned on the cover.

3. Tenders will be received up to 15.00 hrs. on 11.03.2013 in the prescribed form and will be opened on 11.03.2013 at 15.00 hrs onwards at Civil Township Office Conference Hall in the presence of such of those Bidders or their agents who may choose to attend.
4. All entries in the tender documents should be in one ink. Over-writing and corrections should be avoided. The Bidders concerned should duly sign for all corrections and over-writings.
5. Bidder should sign and seal each and every page of the tender document including the drawings/annexure attached thereto before submitting the tender.
6. Conditional tenders and un witnessed tenders, tender containing absurd rates and amounts, tenders, which are incomplete or otherwise, considered defective and tenders not in accordance with the tender conditions laid down by the Accepting Officer are liable for rejection.
7. Tenders not submitted in the prescribed forms are liable for rejection.
8. In quoting the rates, the Bidders are advised to take into account all factors including any fluctuations in the market rates etc. No claim will be entertained on this account after acceptance of the tender or during the currency of the contract.
9. Before tendering, the Bidders are advised to inspect the site of work and its environments and be well acquainted with actual working and other prevalent conditions, position of materials and labor. General instructions to Bidders drawings, specifications and other documents also form part of the agreement to be entered into.
10. The rates quoted in the tender shall remain valid for a period of **THREE MONTHS** from the date of opening of the price bid.
11. In the event of tender being submitted by a firm, the tender must be signed separately and legibly by each partner or member of the firm or in their absence, by the person holding the Power of Attorney on behalf of the firm concerned. In the latter case, a copy of the Power of Attorney duly attested by a Gazette Officer must accompany the tender.
12. **Every Tender must be accompanied by 'Earnest Money Deposit' of Rs.20,000/- (Rupees Twenty thousand only) in the form of Demand Draft drawn from any Nationalized bank, in favor of 'Manager / Finance, BHEL, Ranipet' payable at SBI, Mukundarayapuram Branch (Code : 7013). EMD will not carry any Interest.**

13. Unless the Contractor whose tender is accepted, signs the contract and makes necessary Security Deposit specified within fourteen days from the date of the order directing him to do so, the earnest money deposited by him will be forfeited and acceptance of his tender withdrawn.
14. The Bharat Heavy Electricals Limited, reserves the right to reject any or all the tenders received or accept any tender or part thereof without assigning any reason there for. In case of acceptance of a part of tender, time for completion may also be reduced to the extent considered appropriate by the accepting authority.
15. Unit rates should be quoted in figures as well as in words with reference to each item and for all the items shown in the attached schedule. These rates shall be for the finished work at site.
16. Rates for each item of the tender schedules should be quoted in rupees and paise only. In case of any difference in the rates quoted in figures and in words, words will be taken as the tendered rate.
 - (a) If, in the price structure quoted for the required goods / services / works, there is discrepancy between the unit price and the total price (which is obtained by multiplying the unit price by the quantity), the unit price shall prevail and the total price corrected accordingly, unless in the opinion of the purchaser there is an obvious misplacement of the decimal point in the unit price, in which case the total price as quoted shall govern and the unit price corrected accordingly.
 - (b) If there is an error in a total corresponding to the addition or subtraction of subtotals, the subtotals shall prevail and the total shall be corrected; and
 - (c) If there is a discrepancy between words and figures, the amount in words shall prevail, unless the amount expressed in words is related to an arithmetic error, in which case the amount in figures shall prevail subject of (a) and (b) above.
 - (d) If there is such discrepancy in an offer, the same shall be conveyed to the bidder with target date up to which the bidder has to send his acceptance on the above lines and if the bidder does not agree to the decision of the purchaser, the bid is liable to be ignored.
17. Rates quoted SHALL INCLUDE ALL royalties, terminal taxes, octroi, duties, central and provincial excise tax, sales tax / VAT and other taxes levied under the State or Central Government Rules excluding applicable service tax for this work.
19. **Approximate value of Free materials supplied by BHEL is Rs 0.56 lakhs
(the free issue material is 3.5C x 185 sq.mm Al Ar cable – 120 mtrs)**
20. **The Bidder shall not include Service Tax in their quoted rates ; but the bidder has to separately indicate the Service Tax amount and workings thereof in the Price bid format. Service tax amount if not indicated separately in the price bid schedule in the price bid documents, it will be presumed that the quoted rate is inclusive of applicable service tax and bids will be evaluated accordingly.**
21. **Bidders have to quote full Service Tax payable in the Price format included in the Bid document. Out of Full Service Tax amount indicated by the Bidder, 50% of the same shall be considered for evaluation of offers in the case of Bidders being an Individual, Sole Proprietary ship firm, Hindu Undivided Family or Partnership firm whether registered or not, including Association of Persons. For Other Bidders full Service Tax quoted shall be considered for evaluation.**
22. **In such cases of successful Bidder being an Individual, Sole Proprietary ship firm, Hindu Undivided Family or Partnership firm whether registered or not, including Association of Persons, 50% Service Tax amount quoted in the Price Bid format will be considered for reimbursement against valid documentary evidence. For others Service**

Tax quoted in the Price Bid will be considered for reimbursement against valid documentary evidence.

23. **In such cases of Bidders being an Individual, Sole Proprietary ship firm, Hindu Undivided Family or Partnership firm whether registered or not, including Association of Persons, Service Tax payable by BHEL as receiver of Works contract Service i.e. 50% of the Service Tax payable for Works contracts service on composition basis on quoted price and the value of Free issue materials by BHEL @ 3.708% presently, shall be added to arrive at the total cost to BHEL for each bidder for the purpose of evaluation of Bids.**
24. The quoted rates shall also include expenditures towards complying statutory payments like Provident fund, ESI payments, bonus etc for the labourer & staff deployed in the work.
25. The contractor will have to submit the Service Tax Registration certificate to BHEL and claim the Service Tax from BHEL by submitting Tax invoice as per Rules & Regulations of Service Tax and the documentary evidence will have to be submitted along with the next bill. If for any reason, the contractor has to pay penalty, interest on service tax, the contractor has to bear such additional payment. BHEL will pay only the service tax at actual. **The Bharat Heavy Electricals Limited will not entertain any claim in this regard.**
26. If the bidder find discrepancies or omissions in the tender documents or should be in doubt as to their meaning, he should at once address the authority inviting the tender for clarification. Every endeavor is made to avoid any error which can materially affect the basis of the tender but the successful Bidder shall take up on himself to provide for the risk of any error which may be subsequently discovered and shall make no subsequent claim on account thereof.
27. Tenders submitted by post should be sent "REGISTERED POST WITH ACK.DUE". This should be posted with due allowance for any delay in postal delivery. On no account, will tenders received after the due date and time of opening tenders, be considered.
28. Quantities shown in the attached schedules are only approximate and liable to change without entitling the contractor for any compensation
29. Should a Bidder or a contractor has a relative or in the case of a firm or company of contractors any of its shareholders or share holder's relative, employed in Bharat Heavy Electricals Limited, the authority inviting tenders shall be informed of this fact at the time of submission of the tender failing which tender may be disqualified or if such fact subsequently come to light, the contract may be rescinded.
30. If the Bidder expires after submission of his tender, the Bharat Heavy Electricals Limited may be at the discretion of cancel such tender.
31. If a partner of a firm expires after submission of the tender or after the acceptance of the tender, Bharat Heavy Electricals Limited may cancel such tender at the discretion unless the firm retains his character.
32. The Bharat Heavy Electricals Limited will not bound by any Power of Attorney granted by the Bidder or changes in the composition of the firm made subsequent to the execution of the contract. They may, however, recognize such power of attorney and changes after obtaining proper legal advice, the cost of which will be chargeable to the contract concerned.
33. The contractor deliberately, gives wrong information in his tender or creates conditions favorable for the acceptance of his tender, Bharat Heavy Electricals Limited reserves the right to reject the tender at any stage.

34. Words imparting the singular number shall also deem to include the plural number and vice versa where the context so requires.
35. The expenses for completing and stamping the agreement shall be to the contractor's account.
36. The General and Special Conditions of Contract are complimentary to each other and where they are in conflict, the Special Conditions shall prevail. In regard to matters not covered by the General or Special Conditions of Contract, those contained in the specifications approved by Bharat Heavy Electricals Limited shall apply.
37. Bidders shall not increase their quoted rates in case Bharat Heavy Electricals Limited negotiated for reduction of rates, such negotiations shall not amount to cancellation or withdrawal of the original offer and the rates originally quoted shall be binding on the Bidders for a period of Six months from the date of opening of tender.
38. Canvassing in any form in connection with the tender is strictly prohibited and the tenders submitted by the contractors who resort to canvassing will be liable for rejection.
39. All contractors will have to produce Income Tax clearance certificate from the Income Tax authorities concerned along with their tenders. Those contractors whose income is not taxable will be required to give an affidavit of their income on the prescribed form.
40. The " GENERAL CONDITIONS OF CONTRACT and SPECIAL INSTRUCTIONS TO BIDDERS" shall be deemed to form an integral part of contract for the work to be entered into.
- 41. The contractor should possess necessary licenses, Permanent PF A/c No, and should take Insurance for his workers and produce them before commencement of work. The Contractor shall insure all his materials, tools, tackles etc. and also for third party.**
- a. As per employees PF and misc. provisions Act 1952, the employee's contribution payable at present is 12% of wages which shall be recovered by the Contractor from the wages of his workmen and the contractor should pay equal contribution in addition to any administrative charges in this behalf that may be decided from time to time. Remittance shall be made on time (i.e. on or before 15th of the following month).
 - b. All the contract workers shall be enrolled in ESI (Employees' State Insurance). The effective date will be first day of the latest commencement of running contract concerned. The date shall be entered in the 'Date of Appointment' column of the ESI Declaration Form. The workers who are already members of ESI need not be enrolled again.
 - c. The filled ESI declaration forms shall be submitted to the Executive (HR-CLX, REX). In the Declaration Form full address of the contractor shall be mentioned. Whenever a fresh and unregistered worker is engaged during the operation of contract, declaration form in respect of that workman which should be submitted to Human Resources Department within two days of such engagement.
 - d. ESI contributions (1.75% employees contribution + 4.75% employer contribution of the total monthly wages) before 20th day of every following month. Prescribed challans are available at ESI local office, Ranipet (near Sipcot). Contractors who have got their own code number can remit the contributions on that number.
 - e. Along with the challan copy, the details of remittance shall be submitted to the Executive (HR-CLX, REX) in the ESI compliance form.
42. The contractor should deduct Provident Fund and ESI amount as per the provisions and amount so deducted along with the matching contribution of the contractor shall be remitted to the

authorities concerned within the stipulated time. The statement of deduction along with the challans evidencing remittance shall be submitted to Officer-in-charge. If the evidences are not shown, further bills of the contractor will not be paid.

BHEL have the right to withhold the payment of his bills. Submission of statutory returns such as Half Yearly returns of ESI (Form 6), P.F. return (Form 12A), Form 5 and Form 10, Form 3A & Form 6A should be send to the concerned officers in time.

43. In case of any increase in wage rates on account of revision of minimum wages by Government of Tamil Nadu and any revision of rate of contribution in Provident Fund, ESI and Bonus percentages due to statutory amendments, the contractor is bound to pay the revised amount. In case the revision of minimum wages is made by Government of Tamil Nadu with retrospective dates, the contract is bound to pay such arrears arising out of such revision of minimum wages retrospectively, failing which BHEL as the principal employer will retain the amount from the contractor and pay to contract labourers working under him.
44. The workers' particulars such as Name, Age, Father's name, address etc., and their daily attendance have to be maintained by the contractor. The details of Provident Fund and ESI compliance have to be maintained by the contractor in the prescribed format/register.
45. As per the Contract (Regulation & Abolition) Act, 1970 & Allied Rules, the contractor employing 20 or more labourers is required to obtain license from the Inspector of Labour, Vellore. This license shall be amended and/or renewed whenever there is an increase in the workman employed by him or in the event of contract being extended or renewed. The contractor shall inform the License Number so obtained to the Human Resources Department.
46. The contractor shall maintain the following Registers and Records and make them available for inspection at any time. (The list is only for example, but not exhaustive).
 - a) Muster Roll
 - b) Register of Wages
 - c) Register of Deductions
 - d) Register of Overtime
 - e) Register of Fine
 - f) Register of Advance
 - g) Wage slips
 - h) Register of Accidents
 - i) Register of Leave with Wages
 - j) ESI Register in Form-7

All registers are required to be maintained as above and shall be produced as and when Government Officials and Statutory Authorities to make inspection from time to time.

47. In case a contract labourer meets with an accident while on duty, the contractor shall immediately intimate the information to Safety Department, Contracting Agency and Human Resources Department and submit the Accident Report duly filled in all respect and send a copy to ESI local office, ESI Dispensary and Inspector of Factories (for major accidents) within 24 hours of accident through Safety and Human Resources Departments. All assistance for the injured workman such as taking him to ESI Dispensary for treatment must be rendered by the contractor.
48. Compliance of the above provisions does not absolve the obligation of contractor arising out of other statutory obligations.
49. Employment of child labour is strictly prohibited.

50. Contractor should employ only persons having sound health and not above the age of 58 years, and not below the age of 18 years.
51. Payment of Bonus: In respect of work done by the labour, the contractor has to pay to his labourers as laid down by the Payment of Bonus Act – 1965.
52. The Bidder should be present if called for negotiation both technical and commercial. In case, the Bidder's authorized person is attending the negotiation such person should have the authorization letter and he should be capable of taking spot decisions.
53. In case the Bidder is not interested in submitting your quotation, they should return all the tender papers with a covering letter stating that your regrets for not submitting your offer for this tender.
54. If required bidders may visit the site/working area and obtain all clarifications from Tender Issuing Officer regarding the nature of job before offering their quotation.
55. The bidder shall clearly indicate all the applicable Taxes in the Price Bid and also shall state clearly whether these taxes are inclusive or exclusive of the Basic rate quoted. If any tender does not indicate applicable taxes, BHEL will assume, price quoted is inclusive of all Taxes and Tender will be evaluated accordingly.
56. The contractor should submit notarized copy of the following documents.
 - i. Pan card.
 - iii. TN VAT registration certificate.
 - iv. Service tax registration certificate.
57. The contractor shall indicate all the applicable taxes in the offer and any claim after the issue of contract will not be entertained.
58. In case if any Taxes not applicable, like due to threshold limit etc. Same may be clearly indicated in the offer by the Bidder.
59. The L1 bidder will be identified through the process of summing up the unit rates quoted as per the schedule of works available in price bid including service tax.
60. If, in the price structure quoted for the required goods/ services/ works, there is discrepancy between the unit price and the total price (which is obtained by multiplying the unit price by the quantity) the unit price shall prevail and the total price corrected accordingly, unless in the opinion of the purchaser there is an obvious misplacement of the decimal point in the unit price, in which case the total price as quoted shall govern and the unit price corrected accordingly.
61. If there is an error in a total corresponding to the addition or subtraction of subtotals, the subtotals shall prevail and the total shall be corrected; and
62. If there is a discrepancy between words and figures, the amount in words shall prevail, unless the amount expressed in words is related to an arithmetic error, in which case the amount in figures shall prevail subject of (60) and (61) above.
63. If there is such discrepancy in an offer, the same shall be conveyed to the bidder with target date up to which the bidder has to send his acceptance on the above lines and , if the bidder doesn't agree to the decision of the purchaser; the bid is liable to be ignored.

TENDER DOCUMENT

TENDER NOTICE NO: BAP:M&S:TE:EL:12:015:DT:04.10.2012

Name of work	Electrification work for Sewage Treatment Plant (STP) in BHEL Township, Ranipet- 6.
Period of Contract	Three months

Issued to M/s. :

PART – II – PRICE BID
(Pages 49 to 55)



MAINTENANCE & SERVICES DEPARTMENT
BHARAT HEAVY ELECTRICALS LIMITED
(A Government of India Undertaking)
BOILER AUXILIARIES PLANT
INDIRA GANDHI INDUSTRIAL COMPLEX
RANIPET - 632 406

ISSUING OFFICER

BILL OF MATERIAL					
Name of work : Electrical work for sewage Treatment Plant (STP) in BHEL Township, Ranipet - 6					<u>PRICE BID</u>
Period of Contract : Three Months					
Tender notice no.: BAP:CTS:OT:02/2012-13 Dt. 05.02.2013					
Sl.NO	DESCRIPTION OF WORK	QTY	UNIT	RATE IN Rs.	QUOTED VALUE IN Rs.
(a)	(b)	©	(d)	(e)	(f)=(c) x (e)
1	Laying of 3.5C X 185 sq.mm.alu.conductor PVC insulated armoured cable - <u>Double Runs</u> (20m +20m) on wall / trench / racks/concealed with necessary fixtures etc., as per the BHEL Safety Rules and Special Instructions. Supply Point to STP. 3.5 C x 185 sq.mm cable only will be supplied by BHEL on free issue basis.	20.00	MTR		
2	Laying of 3.5C X 185 sq.mm.alu.conductor PVC insulated armoured cable - <u>Double Runs</u> (40m + 40m) under ground as per the BHEL Safety Rules and Special Instructions. Supply Point to STP. 3.5 C x 185 sq.mm cable only will be supplied by BHEL on free issue basis.	40.00	MTR		
For all items below (Sl. No. 3 to 23), all materials shall be supplied by the contractor within the quoted rates.					
3	Supply and Making end termination with supply of suitable size of cable glands, lugs etc., using anti corrosive paste for single run 3.5C X 185 sq.mm alu.conductor PVCA cable.	8.00	NO		
4	Supply and Fixing of MCB distribution board with 01 No of 25A TPN MCB as incomer with 03 Nos of 16A TPN MCB, as outgoing with in suitable MS Box, with necessary bus bar and interconnections arrangements on the wall with necessary fixtures. A. For Fan and Lights -01 No. B. For Road Lights – 01 No. C. For Spare – 01 No	1.00	SET		

Sl.NO	DESCRIPTION OF WORK	QTY	UNIT	RATE IN Rs.	QUOTED VALUE IN Rs.
(a)	(b)	©	(d)	(e)	(f)=(c) x (e)
5	Supply and open wiring / Concealed wiring with 2.5sq.mm flexible Copper conductor PVC insulated wire, double runs for Phase And Neutral on suitable rigid PVC FLAT conduit pipe / pvc pipe with continuous running of 2.5 sq.mm flexible Copper conductor PVC insulated wire, green color for earthing with necessary fixtures etc., color coding of wires shall be maintained.	20.00	MTR		
6	Supply and Open wiring / Concealed wiring with 1.5 sq.mm Flex. Copper Conductor PVC insulated wire on suitable PVC FLAT conduit / Pvc pipe with 01 No of 5 A Flush type switch (Anchor make) on suitable MS box with necessary fixtures for Lamps and Cei. Fans. One run of 1.5 sq.mm Flexible copper Conductor PVC insulated wire should be laid for neutral of each point. color coding of wire shall be maintained. A) TL - 4 Pnts (Control room - 3 + Chemical room - 1). B) Fan -4 Pnts (Control room - 3 + Chemical room - 1). C) 80W - 3 Pnts (Outside Building - 3). D)Exhaust Fan - 03 Nos (Control room - 2 + Chemical room - 1).	14.00	NO		
7	Supply and fixing of 15A, 6 pin flush type switched socket of Anchor make on suitable MS box with necessary fixtures etc on the wall. A) 04 - Nos (Control room - 3 + Chemical room - 1).	4.00	NO		
8	Supply and Fixing of 1 x 250 W, 230 V, AC, metal halide Street light fitting. Make: Philips / Havells / LVD / RAESP /Bajaj /Crompton greaves on the MS pipe bracket.	10.00	NO		

Sl.NO	DESCRIPTION OF WORK	QTY	UNIT	RATE IN Rs.	QUOTED VALUE IN Rs.
(a)	(b)	©	(d)	(e)	(f)=(c) x (e)
9	<p>Supply and Fixing of Timer Box on wall, make BCH – Size 500 X 700 X 300 mm –Single door Box, cat no: BIL – 50220 or equivalent...</p> <p>A) 24 Hrs Digital Timer, INPUT VOLTAGE -230V, AC,1 NO + 1NC, Frontier make or equivalent.</p> <p>B) 40 Amps, 415 V, NHD size-1, Coil V-230 V,4 pole, BCH make contactor.</p> <p>C) 32A, 12way, open type terminal block.</p> <p>D) 20 A KIT CAT FUSE -03 nos.</p> <p>E) 10 A, 250 V, Bypass Toggle switch.</p> <p>F) Locking arrangements with at least 3 nos of keys shall be supplied with the timer box.</p> <p>All the above items should be neatly fixed in the timer box and wired with suitable wires and all the above items shall be supplied by the Contractor.</p>	1.00	SET		
10	<p>Supply and Laying of 4C X 10 sq.mm.alu.conductor PVC insulated armoured cable on wall / trench / racks/concealed with necessary fixtures etc., as per the BHEL Safety Rules and Special Instructions.</p> <p>A) 16A MCB to Timer box – 04 Mtrs.</p> <p>B) Timer box to poles – 40 Mtrs.</p> <p>C) 25A SFU to 25A MCB DB - 17Mtrs.</p>	70.00	MTR		
11	<p>Supply and Laying of 4C X 10 sq.mm.alu.conductor PVC insulated armoured cable under ground as per the BHEL Safety Rules and Special Instructions.</p> <p>A) 16A MCB DB to Timer box – 06 Mtrs .</p> <p>B) Timer box to poles – 350 Mtrs.</p>	356.00	MTR		

Sl.NO	DESCRIPTION OF WORK	QTY	UNIT	RATE IN Rs.	QUOTED VALUE IN Rs.
(a)	(b)	©	(d)	(e)	(f)=(c) x (e)
12	Supply and Making end termination with supply of suitable size of cable glands, lugs etc., using anti corrosive paste for single run 4C X 10 sq.mm alu.conductor PVCA cable. A) Control room-4 nos. B) on poles-14 nos.	18.00	NO		
13	Supply and Laying of 2C x 1.5 sq.mm Copper conductor PVC insulated flexible cable inside the Pole with necessary fixtures etc., as per the BHEL Safety Rules and Special Instructions.	110.00	MTR		
14	Supply and Fixing of Orient -PSPO / Almonard-Popular/Havells-Velocity model, 1200 mm sweep, single phase AC ceiling fan with suitable MS down rod of length 1.1m and Electronic regulator,5 Steps, Rider / Havells make with necessary fixtures etc., A) Control room - 03 Nos. B) Chemical room - 01 No.	4.00	NO		
15	supply and Pasting of 2mm thick PVC Electrical Insulating Mat as per IS 15652 : 2006 on floor in front of all Panels.	9.00	MTR		
16	Supply and fixing of 300mm Dia Exhaust fan 230 V, 50 Hz, single phase, Brown colour on wall. Fan Make: Orient / Kaitan / Almonard.	3.00	NO		
17	Supply and fixing of 250 V, AC 15 A, 6 Pin switch cum socket with suitable MS Box.	3.00	NO		
18	Supply and fixing of 240V, 50HZ, 2 X36W box type tube light fitting with lamp on wall. Make: Philips or equivalent. A) Control room - 03 Nos. B) Chemical room - 01 Nos.	4.00	NO		

Sl.NO	DESCRIPTION OF WORK	QTY	UNIT	RATE IN Rs.	QUOTED VALUE IN Rs.
(a)	(b)	©	(d)	(e)	(f)=(c) x (e)
19	<p>Supply and Erection of Steel Tubular 10 m Height street light pole with MS pipe bracket, with MS base plate of size 6mm x 300mm x 300 mm. Concrete sizes for pole erection - 500mm Width x 500mm Length x 2000mm Depth below ground level. Concrete coping size above the ground level - 400mm Height x 300mm Length X 300mm Width. 1:3:3 concrete shall be used for basement and coping. 25mm blue metals shall be used for the concrete preparation. Two coats of Al. paint shall be painted on the pole after thorough cleaning.</p> <p>The Pole and MS pipe bracket shall be Fabricated as per BHEL drawing no: ES:M&S:1,2 and as per IS 2713(Part-I to Part-III)-1980.</p> <p>A) 8 SWG GI wire shall be used for coil earthing B) Suitable GI pipe shall be embedded on pole for incoming and outgoing cables separately.</p> <p>C) Earthing of terminal box shall be done using 14 SWG copper Tinned wire.</p> <p>D) At least 3 nos of keys for all the terminal boxes (10 nos) shall be supplied to lock the terminal box.</p> <p>E) MS Pole size: 5200mm L X 139.7mm Dia X 4.5mm Thick + 2400mm L X 114.3 Dia X 4.5mm Thick + 2400mm L X 88.9mm Dia X 3.25mm Thick</p> <p>F) MS Pipe bracket Size: 1000mm L X 76.9mm Dia X 3.25mm Thick</p> <p>G) Fitting fixing pipe size: 200mm L X 50mm Dia X 3.25mm Thick.</p> <p>The Thickness of the MS pipe used for the fabrication of the pole will be checked by BHEL <u>by using D meter</u>. Supply and Fixing of Weather proof MS box of size-200mm height x 240mm length x 150mm depth with 32A x 6way open type terminal block on each pole with necessary clamps. Two coats of Al. paint shall be painted on the MS box after thorough cleaning... The MS box shall be provided with locking arrangement. At least 1.5mm thick MS sheet shall be used for making the MS box.</p>	10.00	NO		

Sl.NO	DESCRIPTION OF WORK	QTY	UNIT	RATE IN Rs.	QUOTED VALUE IN Rs.
(a)	(b)	©	(d)	(e)	(f)=(c) x (e)
20	Supply and fixing of 240V, 50HZ, 2 X36W Weather proof type tube light fitting with lamp and suitable GI pipe bracket Make: Philips or equivalent. Location : Outside Building.	3.00	NO		
21	Supply and Making end termination with supply of suitable size of cable glands, lugs etc., using anti corrosive paste for single run 2C X 1.5 sq.mm copper Flex. PVC A) on pole Termination Boxes-10 nos.	10.00	NO		
22	Supply and fixing of LTCT Metering panel,300amp fuse carrier and fixing 3phase energy meter with neutral link suitable for 130KW capacity and incomer 315 amps switch fuse unit make GE/LT/EE any one. Work is also inclusive of co-ordination works with TNEB obtaining EB Service connection.	1.00	NO		
23	Supply and providing earth pit as per the drawing no; BAP: CTS: EL.PLNG- 2010 .All the materials required for providing earth pit.As per the drawing is under contractor scope. including 6SWG bare wire etc.	2.00	NO		
24	Total Quoted value (Sum of Sl. No. 1 to 23).....= Rs.				
25	Service tax amount as per (g) of table given below=Rs.				
26	TOTAL BID AMOUNT FOR THE WORK (Sl. No. 24 + Sl. No. 25).....=Rs.				
	TOTAL BID AMOUNT IN WORDS :- RUPEES				

SERVICE TAX WORKINGS

a)	Total Quoted value (as per Sl. No. 24).....=Rs.	
b)	Value of free issue materials by BHEL.....=Rs.	56,095.00
c)	Total value including Value of free issue materials (a) + (b).....= Rs.	
d)	Valuation percentage for determining assessable value for service Tax (%) =	60%
e)	Assessable value for Service Tax (c)x (d) / 100.....= Rs.	
f)	Service Tax Percentage	12.36%
g)	Service Tax Amount (e) x (f) / 100.....= Rs.	

SPECIAL INSTRUCTIONS

- 1 Fuse switches / switch fuses shall be of any one of the following make only Gec Alstom, L&T, GEC
- 2 The DP switches, SP Switches, plugs and sockets shall be of standard make agreeable to Engineer in charge and should have been certified by ISI.
- 3 All materials supplied by the contractor should conform to the relevant IS / BS specification.
- 4 Single core, Single / Multi strand cables shall be of ISI approved make only, The armored cable shall be of ISI approved make only, Test Certificate of cables are to be submitted.
- 5 The wiring shall conform to IS 732 or any other relevant INDIAN STANDARD SPECIFICATION and INDIAN ELECTRICITY RULES. The installation shall also conform to the regulation for the electrical equipments of building laid down by Insurance Association of India (FIRE SECTION).
- 6 In case of PVC / steel conduit wiring the switches, plug sockets, regulators and other controls should be mounted on metal boxes. These boxes as well as metal boxes used for street light controls should be fabricated as per IS:5133 (part – 1 1969)
- 7 Final lay out, as well as Electrical drawings etc, should be submitted in advance for BHEL's approval.
- 8 Preparation of Electrical drawings, submitting the same to CEA / Local TNEB authorities to obtain EB Service connection etc, are under the contractor's scope.
- 9 The contractor should be present at the time of inspection of the installation by the Electrical Inspector. Any defect pointed out by the Electrical Inspector in the equipments (or) installations supplied by the contractor should be immediately rectified by the contractor free of cost.
- 10 The 'Completion Report' should be submitted as per Appendix-F of IS 732.

11 Recommended makes of different accessories:

	Name of accessory	Recommended make
01	Luminaries	Philips, GEC, Crompton, Bajaj, Havells
02	Ceiling fans	Orient, Crompton, Usha, Khaitan, Havells, Almonard
03	Switches / Sockets	Anchor, Kundan, Record with FAN/LIGHT marking
04	ICDP / ICTPN Switches	Bosma, Standard, GEM, GE, Raj
05	MCBs /	MDS Loadster, legrand, L&T, Hager, Siemens
06	Rotary switches	Salzer, Kaycee, Siemens, L&T,
07	Metal Clad sockets	Sakthi Crown, B&C/Crompton, BCH
08	Single core cable	ISI approved make only
09	Armored cable	ISI approved make only
10	Fuse Distribution Boards	Bosma, Raj, GE, GEM, Standard
11	Exhaust fans	Orient, Crompton, Usha, Khaitan, Havells, Almonard
12	Combination Fuse Switches	GEC Alstom make
13	Metal Clad Sockets	Best & Crompton, Sakthi Crown

12 **IF CABLE / CABLES HAS TO BE LAID IN GROUND THE FOLLOWING SPECIFICATIONS SHOULD BE FOLLOWED.**

A

For LOW TENSION cable SINGLE run

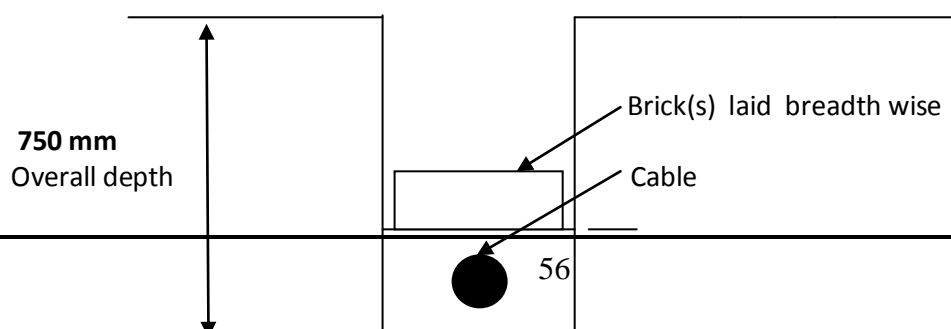

50 mm sand layer

50 mm sand layer

For ONE run of cable : The trench should be excavated to a depth, such that the cable will be laid at a **minimum depth of 750 mm** as shown above. Spread 50 mm deep layer of sand below the cable in trench, after laid the cable, also spread 50 mm deep layer of sand above the cable. Lay good quality bricks **breadth wise** only and cover the sand layer all along the cable / trench. Then complete the earth filling. The bricks shall be of good quality with size 100 mm x 75 mm x 225 mm.

B

For MORE than ONE cable :

For LOW TENSION cables DOUBLE run (or) more the cables shall be laid as shown

below:

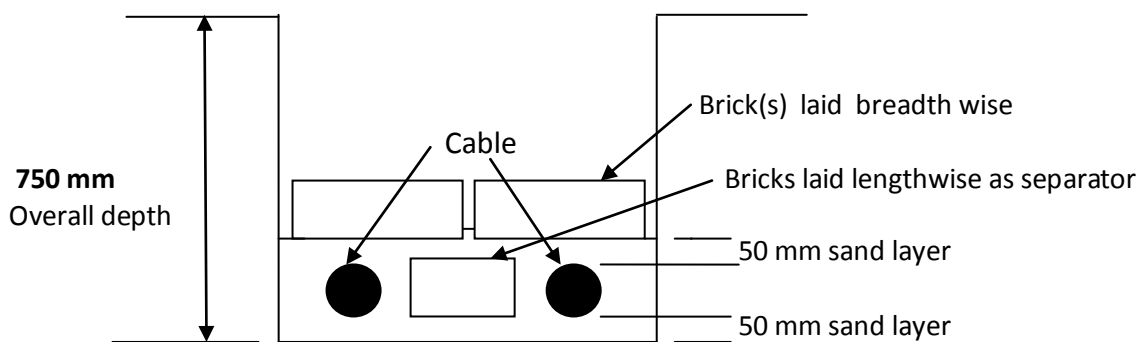

The cables should be laid in horizontal plane. The **trench should be excavated** to a depth and breadth, such that the cables will be laid at a **minimum depth of 750 mm in horizontal plane** as shown above. Spread 50 mm deep layer of sand below the cables. Lay the cables in horizontal plane & place **good quality bricks** in between **them length wise continuously all along the cable / trench**. Further sand filling to be done for 50 mm over the cables.

13

Lay **good quality bricks breadth wise only and cover the sand layer all along the cable / trench**. Then complete the earth filling. The bricks shall be of good quality with size 100 mm x 75 mm x 225 mm.

A

For **HIGH TENSION / 11 KV** cable the **trench should be excavated to a depth**, such that the cable will be laid at **minimum depth of 900 mm**. Spread 50 mm deep layer of sand below the cable in trench. After laid the cable, lay good quality bricks length wise and vertically sideways to make box like arrangement covering both sides of the cable as shown below. Spread 50 mm deep layer of sand above the cable. Lay good quality bricks **breadth wise** only and cover the sand and brick layer all along the cable / trench. Then complete the earth filling. The bricks shall be of good quality with size 100 mm x 75 mm x 225 mm.

For HIGH TENSION cable SINGLE run

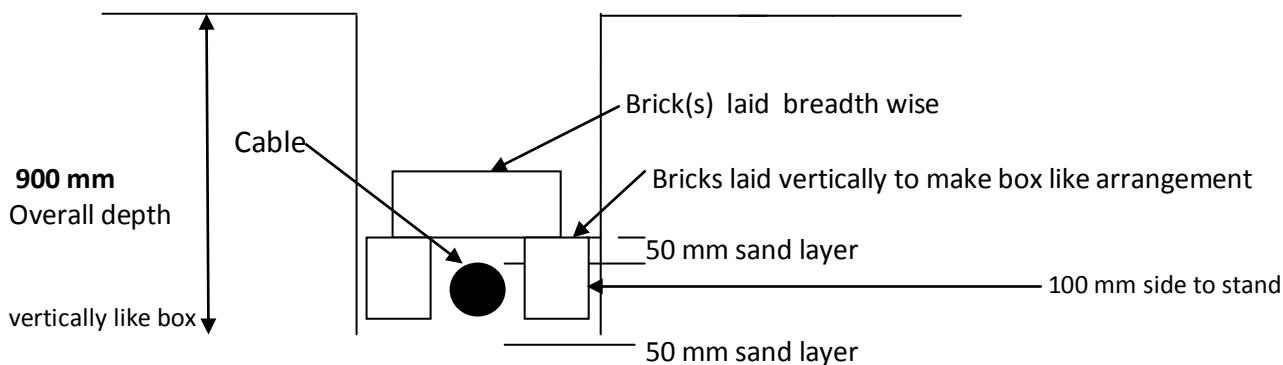

B

For HIGH TENSION cables DOUBLE run (or) more the cables shall be laid as shown below:

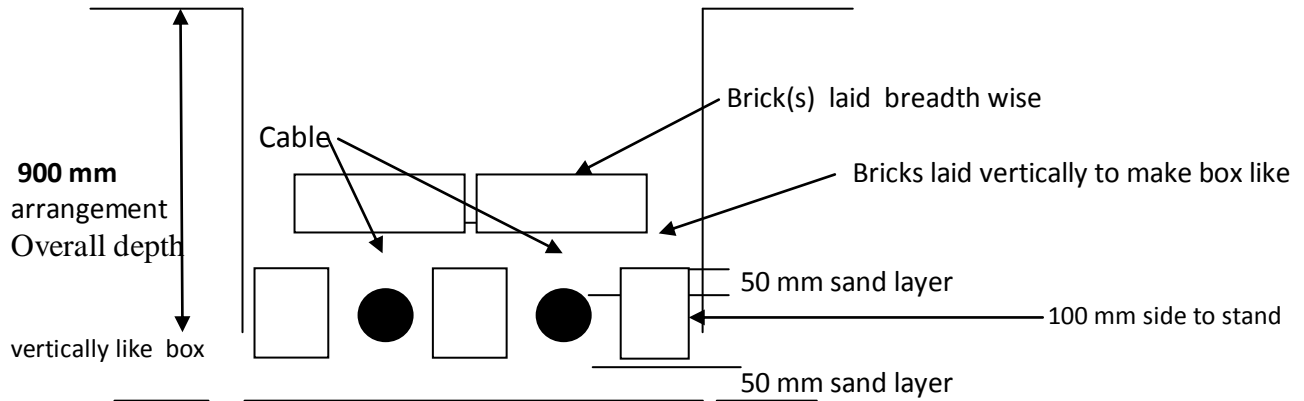

14

In case where cables have to be taken across the road, the pipes have to be laid across the road & the pipes will be supplied by BHEL. However if pipes are already available across the road, the cables have to be taken through that available pipes.

Cable 'Route Indicator' / 'Joint indicator' should be provided once in 20 Metre.

Cable 'Route Indicator' / 'Joint indicator' has to be supplied by the contractor.

15

In case of cable laying in open trench / wall / column, the cable has to be taken with proper clamping in cable trench / wall / column. The clamps are to be supplied by the contractor.

End termination of the cable is inclusive of supply and using of Pin / Eye type, Aluminium / Copper sockets, Glands, MS adopter boxes, Earthing of Glands & adopter boxes with 8 SWG (or) 7/20 GI wire.

PANELS:

16

Cubicle / Industrial type panel boards should be manufactured by any of the reputed manufacturers who have sufficient experience in the manufacturing of Electrical panel boards.

All sheet steel used in the manufacture of Main Panel boards should not be less than 2 mm thick Ms sheet metal. The Main Panel board has to be approved by BHEL before dispatch to the work spot.

For all sheet metal fabrication, pre treatment of all metal with acid and rust preventing chemicals has to be carried. Two coats of red oxide and one coat of recommended color paint has to be applied by spray painting.