

DETAIL	INFORMATION
Contact Person and Address	M.NALLATHAMBI SENIOR MANAGER / CCDP PURCHASE DEPARTMENT/R&D and CR UNIT – HPBP BHEL, TIRUCHY, INDIA PIN : 620 014
Email	mnthambi@bheltry.co.in
Telephone	0091-431-257 7558, 257 7152
Fax	0091-431-2520696, 2520193
Notification (Reference) No.	2821300001 - CR Dt. 02/01/2013
Tender Title	SUPPLY OF OIL FIRED BURNER ASSEMBLY
Tender Type	BUY – Two Part
Brief Description	Oil Fired Burner Assembly of capacity 300 Kg/Hr as per the specification, commercial terms & conditions enclosed
Published in Newspaper	NO
Published On	--
Tender Value in Rs	--
EMD Value - Rs	NIL
Document Cost- Rs	NIL
Date of Issue of Notification -DD/MM/YY	
Date for Closure of Sale of Forms - DD/MM/YY	Not Applicable
Completed Forms to be submitted by - DD/MM/YY	05/02/2013 : 14.00 Hrs IST
Date of Opening for Technical Bids - DD/MM/YY	05/02/2013 : 14.30 Hrs IST

Note:

If the due date of tender opening happens to be a holiday, the tenders will be opened on the next working day.

All clarification may be sought at least seven days prior to tender due date from the undersigned with due written request.

Corrigendum if any, with respect to this tender will be hosted only in the website <http://www.bhel.com> (or) <http://tenders.gov.in>. You are requested to visit the website regularly for updates.

The offer should reach this office on or before the due date & we are not responsible for any postal delay. Late tender will not be considered.



BHARAT HEAVY ELECTRICALS LIMITED

(A Government of India Undertaking)
HIGH PRESSURE BOILER PLANT
PURCHASE DEPARTMENT - FOSSIL BOILERS
THIRUCHIRAPALLI - 620014
TAMILNADU (INDIA)

PHONE :2577383
GRAMS : BHARATELEC
FAX NO: 2520696
E-mail: ssraj@bheltry.co.in
Web:

429-002/A

	Enquiry No	Enquiry Date	Due Date for Quotation
	2821300001 - CR	02.01.2013	05.02.2013
Please quote Enquiry No, Date and due date in all correspondences. This is only a request for quotation and not an order			

Item	Description	Unit	Quantity	Delivery Quantity	Schedule Date
10	OIL BURNER ASSEMBLY	NO	1.000	1.00	14.03.13
	Supply of Oil fired Burner Assembly of Capacity : 300 kg/h., Turn-down Ratio 1:3 and as per the enclosed specification. Oil burner for LDO or HFO to air preheat				

General Note:

- 1) Offer will be invited in TWO PART BID only (i.e. Technical Bid and Price Bid - in two separate envelopes. Make mention on the top of the covers "TECHINCAL BID" cover and "PRICE BID" cover;
- 2) If regretted make mention on the top of the reply cover as "REGRETTED";
- 3) LD Clause for delivery has to be confirmed without fail. Otherwise we would assume that you have accepted our LD Clause;
- 4) Required : a) Test certificate, b) Guarantee certificate and c) Third Party Inspection;
- 5) The preferred Payment Term is "100% PAYMENT AFTER RECEIPT AND ACCEPTANCE OF THE MATERIAL";
- 6) Advance or Proforma Invoice Payment is not accepted;
- 7) Transport and Delivery at BHEL - shall be Vendor's scope;
- 8) Detailed Specification is enclosed;
- 9) Tender details also hosted in BHEL Web : www.bhel.com.

Enclosures:

"LD clause has to be confirmed without fail."
"Payment to vendors will be made only thro E-Payment mode"

The offers should reach us 30 minutes before the time of opening of tenders.
The offers will be opened at 14.30 hrs on the due date of tender in the presence of tenderers who have submitted their offer and who may like to be present for the tender opening. Late and delayed offers are liable to be rejected.

Yours faithfully,
For **BHARAT HEAVY ELECTRICALS LIMITED**

S. SUBBURAJ
Manager
Purchase / R&D and CR
Bharat Heavy Electricals Limited
Tiruchirappalli - 620 014

MANAGER / PURCHASE
(FOSSIL BOILERS)
Yours faithfully,

**Bharat Heavy Electricals Limited – Tiruchirapalli
COAL RESEARCH CENTRE**

Specifications for Oil Fired Burner

Oil Burner Specification

Application :

The oil burner is to be used in a combustor to generate hot flue gas. This hot flue gases are diluted with fresh air from tempering air fan, the resulting flue gas and air mixture is used to preheat fresh air using a rotating heat exchanger. The preheated air then be used pulverized coal combustion experiments. The capacity of the oil burner is 300 kg/h. The oil used is either LDO or Furnace oil.

Item No	BHEL Specifications / Requirements	Vendor's Offer
1	An oil burner Mono Burner block consists of	
a	Combustion head	
b	Nozzle Lance	
c	Pressure regulating valve,	
d	Blower	
e	Oil pump	
g	Filters	
h	Driving motor	
i	Spark igniter	
j	Oil heater	
k	Flame scanner	
l	View port	
m	Retractable arrangement	
n	Oil to be fired - light diesel oil (LDO)/FO	
2	Burner Capabilities	
a	Capacity of the burner - 300 kg/hr	
b	Turndown Ratio - 1:3	
3	C&I Specifications	
a	All field gauges (Pressure, Temperature)	
b	Switches (Manual /Auto, for solenoid, for motor, for ignition)	
c	Spark igniter	
d	Ignition Transformer	
e	Flame sensors	
f	Oil pre-heater and control	

**Bharat Heavy Electricals Limited – Tiruchirapalli
COAL RESEARCH CENTRE**

Specifications for Oil Fired Burner

g	Control panel with necessary safety interlocks,	
h	Indication lamps(power on, Burner ON/OFF, Burner trip)	
i	Push buttons	
j	Indicating instruments	
k	Motor starters and rain hood	
l	IP-40 electric protection level	
4	10 metre interconnecting cables between burner equipment and control panel and cabling accessories like double compression type glands and lugs	
5	Valves and Fittings	
6	Mandatory spares list with unit price	
7	Any additional safety equipment (give it as optional items)	
8	Documents required	
a	Block diagram for the scope, P&ID, BOM (discrete items of burner) Control panel GA with dimensions, BOM for Control panel mounted items	
b	Detailed specification +make+ model for each item covered under vendor scope	
c	Write up on the system offered	
d	Quality Assurance Plan (QAP)	
e	List of consumables	
f	Interconnection diagram for the burner accessories and control panel accessories	
g	Valid test certificate to be furnished (if any)	
h	Product catalogues	

Existing power supply and fuel supply information

Supply oil burner for the following electrical and fuel supply compatibilities

1. Power supply: BHEL provides only 1 No 415 V, 3Ph, 50 Hz feeder. Any other accessories that are specific to burner must be arranged by vendor.
2. Fuel supply: Fuel oil will be supplied from the local storage tank by an oil pump at 2 kg/cm², 35 DegC to the manifold with bypass lines near the burner.

**Bharat Heavy Electricals Limited – Tiruchirapalli
COAL RESEARCH CENTRE**

Specifications for Oil Fired Burner

3. Refractory lined Combustion chamber dimensions 4500mm (L) x3100mm (W) x2200mm (H)
4. Separate ignition fuel is not available
5. Separate compressed air for atomization not available

Commissioning:

Commissioning of the oil burner at BHEL Trichy site should be supported by vendor

Inspection:

BHEL Trichy will inspect the oil burner assembly at vendor's works site.

Guarantee:

18 months from commissioning or 24 months from supply whichever is earlier.

Delivery:

Our preferable delivery time for the oil burner is within 8 weeks of placing the purchase order.

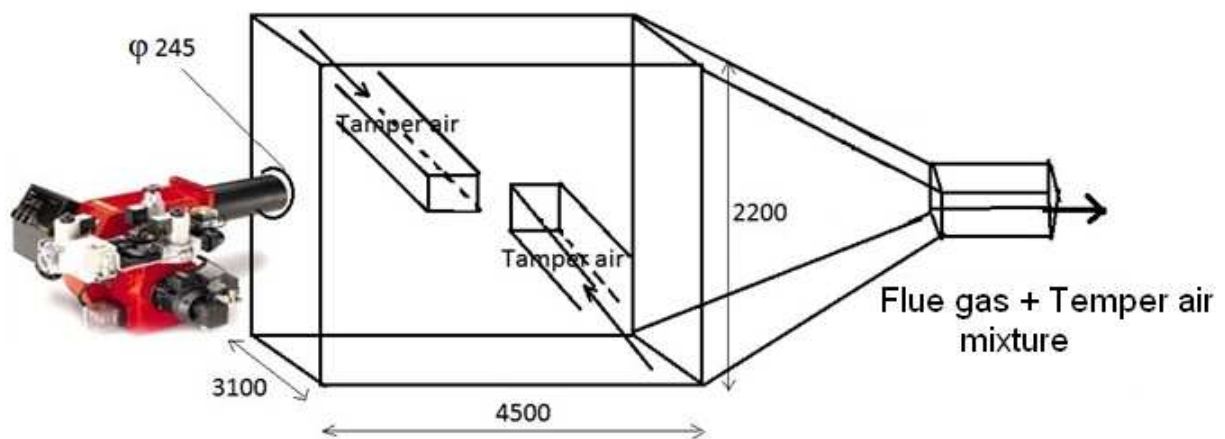

Figure: Schematic diagram combustion chamber with oil burner. All dimensions are given in "mm" and drawn not according to scale.

**Bharat Heavy Electricals Limited – Tiruchirapalli
COAL RESEARCH CENTRE**

Qualifying criteria for supply of Oil Fired Burner

Ref : BHE: CRC:2

Dt : 29-12-2012.

QUALIFYING CRITERIA

The BIDDER / VENDOR have to necessarily provide the following details, for making an assessment of the firm's capability and competency.

The bid consists of 2 parts namely Technical and Price bid. Vendor shall submit Technical and Price bid separately. BHEL will study both the Qualifying Criteria and Response for Technical Specifications. The Price bid can be studied only if both the Qualifying Criteria and Response for Technical Specifications are found acceptable.

[The BIDDER is expected to give complete details against each clause in the table given below and wherever necessary an additional sheet may be attached giving clear reference number to cover the required details]

Name of the product: LDO/FO fired oil burner

Please refer Technical Specification for further details.

S. No.	PARTICULARS	VENDOR's RESPONSE
1.0	The BIDDER/VENDOR or their Principal shall have a minimum of FIVE Years of Continuous Experience in the Design, Manufacture & Supply of Oil burners. Please indicate the actual experience.	
2.0	Number of " Oil Fired Burner " supplied till date in India and abroad. Please furnish contact person name, address, phone number, fax number and mail id.	
3.0	Please enclose Performance Certificate from atleast one Indian or Foreign customer.	
4.0	Details of Technical Back-Up assured from the PRINCIPAL supplier.	
5.0	The BIDDER/VENDOR shall assure a continuous support for SERVICE for Five Years, from the date of installation of the item at BHEL Works.	



Bharat Heavy Electricals Limited
Purchase Department / R&D and CR
Coal Research Centre Building
Tiruchirappalli-620014, Tamil Nadu, India

An ISO 9001 Company

COMMERCIAL TERMS AND CONDITIONS FOR SUBMISSION OF OFFER

1.0 QUOTATIONS

Bidders shall submit the offer in **TWO INNER ENVELOPES** as indicated below which shall be sealed in one outer envelope.

Envelope I This sealed envelope should contain all the copies of technical bid together with un-priced commercial bid. This envelope should be clearly marked **"Part I - Technical and commercial bid"**, indicating Enquiry No., Due Date and Address & Reference of the Bidder.

Envelope II This sealed envelope should contain **price details**. This envelope should be clearly marked **"Part II - Price bid"**, indicating Enquiry No., Due Date and Address & Reference of the Bidder.

Both the envelopes (Part I & II) shall be put in one cover, duly sealed, superscribing as Part I and Part II of Enquiry No., due date of opening and the address and reference of the Bidder.

The above offer should reach this office on or before the due date by 14.00 Hrs (IST). Late offers will not be considered. We suggest you to send the offer by SPEED POST.

Tender should not be addressed to any Individual's name but only by designation to:

AGM / CCDP and BD
Purchase Department / R&D and CR
Coal Research Centre Building
BHARAT HEAVY ELECTRICALS LIMITED
TIRUCHIRAPALLI - 620 014
TAMIL NADU, INDIA

Tenders should be free from **CORRECTION AND ERASURES**, Corrections if any, must be attested. All amounts shall be indicated both in words as well as in figures. Where there is difference between amount quoted in words and figures, amount quoted in words shall prevail.

Offers should be in **ENGLISH** and accompanied by detailed technical literature, catalogue and details of process facility in **ENGLISH**.

2.0 PART I (TECHNICAL & COMMERCIAL BID)

2.1 Technical

This part shall include / indicate the following:

Offer should contain complete scope of supply with all technical details, specifications, delivery and other commercial terms and conditions.

2.2 Commercial

This part shall include / indicate the following:

- 2.2.1. Port of shipment / Station of despatch
- 2.2.2. Terms of payment
- 2.2.3. Taxes & duties applicable.
- 2.2.4. Delivery Schedule
- 2.2.5. Offer validity
- 2.2.6. Country of origin
- 2.2.7. A copy of "Un-Priced Part II" i.e., a copy of the Price Bid **without the price details** to be enclosed.

3.0 PART II (PRICE- BID)

This part should contain the schedule of price particulars and to be co-related to the technical details provided in Part I.

4.0 OPENING OF TENDERS

The Part I - Technical & commercial bid alone would be opened on the Tender opening date.

The Part II - Price bid of Technically suitable Bidders alone would be opened. The Technically suitable Bidders would be informed about the price bid opening date. Clarifications if any required by BHEL for Technical evaluation would be sought from Bidders before opening of Part II - price bid.

5.0 GENERAL

5.1. Incomplete offers will not be considered.

5.2. **Terms of Delivery:** Bidders are required to quote their best delivery period. Foreign Bidders should submit their offer for net **FOB - Nearest Sea Port / Air Port**. Indian Bidders should submit their offer for **Ex-Works basis**. Delivery shall be counted from the date of Letter of Intent.

5.3. **Taxes and Duties :** All Taxes and Duties payable as extra to the quoted price should be specifically stated in offers along with CST & TIN No etc., failing which the purchaser will not be liable for payment of such Taxes and Duties.

5.4. Liquidated damages : It is clearly understood among the parties to the contract the “ **Time is the essence of the contract** ”. Therefore, the delivery of the goods specified in the purchase order should be made within the time prescribed. Failure to dispatch the materials in the time as per the delivery quoted in our Purchase Order would make the supplier liable to an un-conditional penalty at the rate of 1/2% of the value of goods for each week of delay subject to a maximum of 15% of the order value.

5.5. Risk purchase : Alternatively the purchaser at his option will be entitled to terminate the contract and to purchase elsewhere at the risk and cost of the seller either the whole of the goods or any part which the supplier has failed to deliver or despatch within the time stipulated as aforesaid or if the same were not available, the best and the nearest available substitute therefor. The supplier shall be liable for any loss, which the Purchaser may sustain by reason of such risk purchases.

5.6. Test certificates: The Bidders shall clearly mention in their offer that Test Certificates as called for in the Technical Specification, in the required number of copies will be provided at no extra cost.



BHARAT HEAVY ELECTRICALS LIMITED
TIRUCHIRAPALLI – 620014

PURCHASE / R&D and CR

ANNEXURE TO PURCHASE ENQUIRY

1. PRICE : Ex-Works / Ex-Godown (or) F.O.R- DESTINATION
2. DISCOUNT : % (or) Lumpsum amount Rs
3. PACKING & FORWARDING : % (or) Lumpsum amount Rs
4. TAX : VAT.....% / CST %
(CST Without C FORM)
5. SURCHARE :%
6. DUTIES :%
7. FREIGHT & INSURANCE :
8. DELIVERY PLACE :
9. DELIVERY PERIOD :
10. LD / PENALTY FOR DELAY IN DELIVERY : @ 0.5% PER WEEK SUBJECT TO A MAXIMUM OF 15% IS APPLICABLE. ACCEPTED
11. OFFER VALIDTY :
12. PAYMENT TERM : 100% Payment within 45 Days after Receipt and Acceptance of the Material.
13. GUARANTEE / TEST CERTIFICATE :

SIGNATURE OF SUPPLIER WITH SEAL

NOTE : Please do not Quote as EXTRA. Quote the rate in % or the amount as lumpsum. (Rates of applicable Taxes & Duties, whether inclusive or exclusive should also be mentioned).



BHARAT HEAVY ELECTRICALS LIMITED

R&D / PURCHASE

TIRUCHIRAPALLI - 620 014.

PURCHASE ENQUIRY - TERMS & CONDITIONS

1. a) QUOTATIONS : Each tender should be sent in double cover, inner cover should be sealed with tenderer's distinctive seal and super scribed with correct tender No. item of supply and due of opening. The outer should only bear the address of this office and should not have any indication that a tender is within. Two or more quotation should not be sent in one cover but the quotation against each tender should be sent separately to avoid confusion. Tender should not be addressed to any individual's name but only by designation.
b) Tender should be free from CORRECTION AND ERASURES. Correction if any, must be attested. All amounts shall be indicated both in words as well as in figures. Where there is difference between amount quoted in words and figures, amount quoted in words prevail.
c) PRICE should be nett F.O.R. dispatching station inclusive of risk in transit and remain valid for 60 days from the due date.
d) If any Sales Tax is payable as extra to the quoted price it should be specifically stated in quotations alongwith CST & TNGST No. failing which the purchaser will not be liable for payment of Sales Tax. Our T.N.G.ST. No. 356005, Dated 01-04-1995, C.S.T. No. 239383, Dated 11-06-1991.
e) NO REVISION OF PRICES will be entertained after tenders are opened.
f) Manufacturer's Name, Trade Mark or Patent No. if any should be specified. Illustrative leaflets giving technical particulars are required along with quotation wherever necessary.
g) Products with I.S.I. certification marks will be preferred.
h) The purchaser shall be under no obligation to accept the lowest or any other tender and shall be entitled to accept or reject any tender in part or full without assigning any reason whatsoever.
2. SAMPLES : Wherever possible, sample should be submitted separately whether specifically requested or not so as to reach the purchaser on or before the due date of the enquiry. They should be clearly marked with the Enquiry No. and the date on the outside cover to facilitate identification.
3. PACKING AND MARKING : The supplier shall arrange for securely protecting and packing the stores to avoid loss or damages during transit.
4. TERMS OF PAYMENT : Payment will be made within 45 days of satisfactory receipt of materials at site. Wherever required by the purchaser, the successful tenderer must send the operation and maintenance manuals, Test certificates, Drawings, etc., for the materials ordered. These should be sent immediately after dispatch of the materials and a statement to that effect should be made in the Invoice. Failure to comply with this provision will result in delay in payment of the Bills. Goods dispatched either by V.P.P. or by the document presented through bank will be accepted unless agreed to by the Purchaser.

The duplicate copy of the Invoice meant for the transporters should accompany the material as stipulated under C.E. Rules 52-A and 173-C (or) 57GG. A Photostat copy of the above Invoice for each delivery challan should be submitted alongwith the original bills router through Bank or submitted directly to BHEL Finance Department.
5. SECURITY DEPOSIT : For purchase over Rs. 5000/-the successful tenderer/s may be requested to furnish a BANK GUARANTEE / SECURITY DEPOSIT for an appropriate value as may be determined by BHEL.
6. LIQUIDATED DAMAGES / PENALTY AND INTEREST ON ADVANCEES FOR DELAY IN DELIVERY : "If the supplier fails to deliver the raw material / Equipment / Components within the period specified in the contract the purchaser shall deduct LIQUIDATED DAMAGES a sum equivalent to 0.5% of the Price for each week of delay upto a maximum of 15% of the price of the delayed / undelivered goods. In addition to the recovery of interest at normal cash credit rate plus 2% for the unadjusted portion of the advances. If the delay in delivery of a part contributes to delay in execution of total system. LD and interest on advances will be recovered on the total contract price / total advance paid".
7. RISK PURCHASE : Alternatively the purchaser at his option will be entitled to terminate the contract and to purchase elsewhere at the risk and cost of the seller either the whole of the goods or any part which the supplier has failed to deliver or dispatch within the time stipulated as aforesaid or if the same were not available, the best and the nearest available substitute therefore. The supplier shall be liable for any loss which the Purchaser may sustain by reason of such risk purchases in addition to penalty at the rate mentioned in clause 6 above.
8. PREFERENTIAL DELIVERY : It should be noted if a contract is placed on a higher tenderer as results of this invitation to tender in preference to the lowest acceptable offer in consideration of the earlier delivery, the seller will be liable to pay to the purchaser the difference between the contract rate and that of the lowest acceptable tender on the basis of final price F.O.R. DESTINATION, including of all elements of Frights, Sales Tax, Duties and other incidents, incidental in case of failure to complete supplies in terms of such contract within the date of delivery specified in the tender and incorporated in the contract.
9. MODVAT CREDIT : If any Excise Duty is payable, the chapter Head / Sub-Head reference and the rate of the duty should be quoted. If the tender is availing MODVAT credit for his input materials, the effect of Proforma credit should be passed on to the purchaser. Tenderer under "MODVAT" shall be preferred.
10. GENERAL : The purchaser reserves the right to split up the tender and place order for individual terms with different tenderers and also increase or decrease the quantity.

Any other Conditions which might have been quoted by the Seller and are in contravention to the terms prescribed in the order and which have not been specifically accepted in by Purchaser will not be applicable to the Contact.

* * * *