



An ISO 9001  
Company

**Bharat Heavy Electricals Limited**  
(High Pressure Boiler Plant)  
Tiruchirappalli – 620014, TAMILNADU, INDIA  
**OUTSOURCING**

<b>UNIVERSAL BEAMS/PARALLEL FLANGE BEAMS WANTED</b>	Phone: +91 431 2574204/2574203 Fax : +91 431 252 0719 Email : <a href="mailto:sasokkumar@bheltry.co.in">sasokkumar@bheltry.co.in</a>
---	--

	<b>Reference Number:</b> Enquiry <a href="#">1101300022</a>	<b>Enquiry Date:</b> 23.09.13	<b>Due date for submission of quotation: 11.11.13</b>
--	--	----------------------------------	---

You are requested to quote the Enquiry number date and due date in all your correspondences. This is only a request for quotation and not an order

**Sealed Tenders are invited by the MM / Steel for approx. 1775 MT Hot Rolled Universal Beams (UB), Narrow Parallel Flange Beams (NPB) and Wide Parallel Flange Beams (WPB), generally called as H-Beams confirming to International Standard EN-19-57 & EN-53-62 and Indian Standard IS 12778 & IS 12779.**

BHEL commercial terms & conditions with Price Bid formats and all annexure can be downloaded from BHEL web site <http://www.bhel.com> or from the Government tender website <http://tenders.gov.in> (public sector units) Bharat Heavy Electricals Limited) under enquiry reference "1101300022 "

Tenders should reach us before 14:00 hours on the due date Technical bid will be opened at 14:30 hours on the due date Tenders would be opened in presence of the tenderers who have submitted their offers and who may like to be present.	Yours faithfully, <b>For Bharat Heavy Electricals Limited</b>  Manager/ MM / Steel 2 <sup>nd</sup> Floor, Bldg 24, BHEL, Tiruchirappalli-620014 Ph: 0431- 2574203, Fax: 0431- 2520719 Email: <a href="mailto:sasokkumar@bheltry.co.in">sasokkumar@bheltry.co.in</a>
---	---



# BHARAT HEAVY ELECTRICALS LIMITED

( A Government of India Undertaking )  
HIGH PRESSURE BOILER PLANT  
PURCHASE DEPARTMENT - FOSSIL BOILERS  
THIRUCHIRAPALLI - 620014  
TAMILNADU (INDIA)

PHONE :2574204  
GRAMS : BHARATELEC  
FAX NO: 2520719  
E-mail: maruthu@bheltry.co.in  
Web:

429-002/A

	<b>Enquiry No</b>	<b>Enquiry Date</b>	<b>Due Date for Quotation</b>
	1101300022 - 21	23.09.2013	11.11.2013
Please quote Enquiry No, Date and due date in all correspondences. This is only a request for quotation and not an order			

Item	Description	Unit	Quantity	Delivery Quantity	Schedule Date
10	150090420000 BEAM 600 X 220 - IS2062E250B (Fe410W)	MT	400.000	400.00	26.12.13
20	150090430000 H-BEAM 700 X 300 -IS2062 Gr.B. (149.9 kg/m)	MT	75.000	75.00	26.12.13
30	150090440000 H-BEAM 700 X 300 -IS2062 GR.B. (204.5 kg/m)	MT	500.000	500.00	26.12.13
40	150090480000 BEAM 500 X 200 - IS2062E250B (Fe410W)	MT	100.000	100.00	26.12.13
50	150090490000 H BEAM 305X165 -IS2062E250B (Fe410W)	MT	250.000	250.00	26.12.13
60	150090560000 H BEAM 203X133X25 - IS2062E250B (Fe410W)	MT	50.000	50.00	26.12.13
70	150090570000 H BEAM 254X146 - IS2062E250B (Fe410W)	MT	150.000	150.00	26.12.13
80	150090580000 H BEAM 406 X 178 - IS2062E250B (Fe410W)	MT	100.000	100.00	26.12.13
90	150090600000 H BEAM 356 X 171 X 51- IS2062E250B (Fe410W)	MT	150.000	150.00	26.12.13

### General Note:

### General Terms & Conditions

1...Supply of Hot Rolled Parallel Flange Beams to specification ASTM A36/IS2062 Gr A/B (Fe410W). Beams shall be supplied in length 12 m with steel in fully killed or semi killed condition. Welded beams will not be accepted.

The offers should reach us 30 minutes before the time of opening of tenders. The offers will be opened at 14.30 hrs on the due date of tender in the presence of tenderers who have submitted their offer and who may like to be present for the tender opening. Late and delayed offers are liable to be rejected.

Yours faithfully,  
For BHARAT HEAVY ELECTRICALS LIMITED

**S. ASOKKUMAR**  
Manager  
MM / RM / Steel (Purchase)  
BHEL, TRICHY - 620 014  
MANAGER / PURCHASE  
(FOSSIL BOILERS)  
Yours faithfully,

28/09/2013



# BHARAT HEAVY ELECTRICALS LIMITED

( A Government of India Undertaking )  
HIGH PRESSURE BOILER PLANT  
PURCHASE DEPARTMENT - FOSSIL BOILERS  
THIRUCHIRAPALLI - 620014  
TAMILNADU (INDIA)

Page  
2/4  
PHONE :2574204  
GRAMS : BHARATELEC  
FAX NO: 2520719  
E-mail: maruthu@bheltry.co.in  
Web:

1101300022 / 23.09.2013

2.,,For dimensions and sectional properties refer Table 1.1(as enclosed). Your offer shall indicate the specification referred and any deviations against our specification will not be accepted. The section weight for item 20 & 30 is respectively 149.9 Kg/M and 204.5 Kg/M

3.,,Invoicing - Invoicing shall be on actual weight basis. However in case of any discrepancies in weighment, the weight recorded at BHEL will be final.

4.,,Inspection and testing:

- a)Test Certificate shall incorporate following details i.e. The standard to which the material comply e.g. Specification (e.g. ASTM A36), Melt no, BHEL order no, supplier name , logo, identification no ,TC no, size, results obtained in chemical analysis and mechanical testing. The Test Certificates shall bear the signature of the competent personnel.  
b) Marking in material: Manufacturer's name/logo and specification (grade) are to be marked legibly.  
C) For new vendors Pre Despatch Inspection shall be conducted.

5.,,Delivery: Our required delivery if 30-45days from PO. Quantity tolerance is +/- 10% for individual items. BHEL reserves the right to change the tender quantity and supplier shall indicate acceptance of Part Ordering in their offer, otherwise the offer is liable for rejection.

6.,,Confirm your acceptance for Liquidated Damage for delayed supplies. (0.5% per week and 15% maximum on undelivered portion of the materials).

7.,,Confirm acceptance for Risk Purchase clause.

8.,,Offer is to be submitted in TWO PART BID SYSTEM i.e. Techno Commercial Bid + PRICE BID

9.,,Technical Bid: This shall include Ex-works, port of loading, country of origin acceptance of terms and conditions as per the enquiry, payment terms, specification of the material offered, and the mills details. The contract shall be governed by INCO-Terms 2010. In addition to this new suppliers shall provide details such as mill capacity, credentials, previous purchase orders executed for blue chip companies, ISO certification, details of facility installed, Quality manual, D & B reports in case of foreign sources, and mill details.

10.,,Price Bid (Rate):

- a),,For import supplies, submit your competitive offer in FOB and CFR-Chennai rate /MT basis.  
b),,Indigenous suppliers shall submit basic price/MT, freight, and statutory duties like ED, CST/VAT and Service tax on freight

The offers should reach us 30 minutes before the time of opening of tenders. The offers will be opened at 14.30 hrs on the due date of tender in the presence of tenderers who have submitted their offer and who may like to be present for the tender opening.Late and delayed offers are liable to be rejected.

Yours faithfully,  
For BHARAT HEAVY ELECTRICALS LIMITED

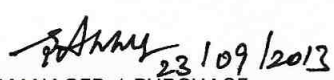
  
**S. ASOKKUMAR** MANAGER / PURCHASE  
Manager (FOSSIL BOILERS)  
MM / RM / Steel (Purchase) Yours faithfully,  
BHEL, TRICHY - 620 014.



# BHARAT HEAVY ELECTRICALS LIMITED

( A Government of India Undertaking )  
HIGH PRESSURE BOILER PLANT  
PURCHASE DEPARTMENT - FOSSIL BOILERS  
THIRUCHIRAPALLI - 620014  
TAMILNADU (INDIA)

Page 3/4  
PHONE :2574204  
GRAMS : BHARATELEC  
FAX NO: 2520719  
E-mail: maruthu@bheltry.co.in  
Web:

1101300022 / 23.09.2013

11.,,Price quoted shall remain firm for a minimum validity of 90 days and shall not be revised at any cost within the validity.

12.,,Only manufacturer (import & indigenou) shall respond to this enquiry. Also exclusive Indian agent can represent ONLY one foreign principal. The offer will be rejected in case of any deviation.

13.,,Furnish your principal's (manufacturer) supply details made to other customers in India for these items.

14.,,In case of Import manufacturer, full details of the Indian Agent/respective Liason office to be provided in the offer.

15.,,Agency agreement in the format attached to be submitted by Indian Agent. Agency commission, if any should be clearly specified in the offer (as % on FOB & % on CFR Chennai inclusive).

16.,,Service charges & incidental charges will not be paid extra.

17.,,Evaluation Criteria:

A) For indigenou supplies, quote your firm rate per MT basis with inclusive of all charges like inspection, UT charges etc. PVC is not acceptable. Freight rate is to be quoted separately without fail. Any other extra charges like ED, CST/VAT etc are to be indicated. The offer will be evaluated on total landed cost to BHEL-Trichy.

a. (i.e.) Total landed cost = Basic + Freight (Within Tamil Nadu)

b. (i.e.) Total landed cost = Basic + Freight + CST (Other than Tamil Nadu)

B) For import supplies:

Submit your competitive offer with best possible delivery on both FOB and CFR Chennai basis only. In case the offer is submitted without FOB or CFR, offer is liable for rejection. The offer will be evaluated on total landed cost to BHEL-Trichy taking into CFR Chennai cost, inland freight (Chennai port to Trichy) and duty if any.

(i.e.) Total landed cost = CFR Chennai + Customs duty as applicable + Inland Freight (as applicable at the evaluation) + LC establishment charges if applicable.

BHEL reserves the right to order on FOB or CFR whichever is found economical considering current BHEL approved Ocean freight rates.

18.,, Payment terms: Our payment term is 60 days after receipt and acceptance of material at our stores only.

For Import: After 60 days from the receipt of materials at our works (CAD). For import supplies, CAD payment is preferred. Otherwise LC will be opened one month prior to material readiness indicated by the mill. LC establishment charges to suppliers account only.

19.,,Submit your competitive offer (Technical & Priced bid) on or before due date (~~XX-09-2013~~) by 14.00hrs. Offers shall be submitted by 11.11.2013

The offers should reach us 30 minutes before the time of opening of tenders. The offers will be opened at 14.30 hrs on the due date of tender in the presence of tenderers who have submitted their offer and who may like to be present for the tender opening. Late and delayed offers are liable to be rejected.

Yours faithfully,  
For BHARAT HEAVY ELECTRICALS LIMITED

  
23/09/2013  
**S. ASOKKUMAR**, MANAGER / PURCHASE  
Manager (FOSSIL BOILERS)  
MM / RM / Steel (Purchase) Yours faithfully,  
BHEL, TRICHY - 620 014



# BHARAT HEAVY ELECTRICALS LIMITED

( A Government of India Undertaking )  
HIGH PRESSURE BOILER PLANT  
PURCHASE DEPARTMENT - FOSSIL BOILERS  
THIRUCHIRAPALLI - 620014  
TAMILNADU (INDIA)

PHONE :2574204  
GRAMS : BHARATELEC  
FAX NO: 2520719  
E-mail: maruthu@bheltry.co.in  
Web:

Page  
4/4

1101300022 / 23.09.2013

hand, by post or by e-mail so as to reach us before 14 hrs. (IST) of the due date mentioned in the enquiry. Late offers will not be considered. Tender will be opened on ~~09.09.2013~~ by 14:30 Hrs.

11.11.2013

20.,, In case if your mill is technically suitable for our requirement, and is supplying for the first time to us, then you have to supply minimum quantity on mutually agreed basis. After acceptance of material at our end after testing by BHEL, clearance for the balance quantity shall be given.

21.,,BHEL reserves the right to negotiate/Re-float the tender if the prices are not found competitive.

**Enclosure:**

- 1.,,Table 1.1 - Dimensional & sectional properties
- 2.,,Terms & Conditions (Import & Indigenous)
- 3.,,Agency agreement format (Import)
- 4.,,Supplier registration form Indigenous.
- 5.,,Supplier registration form Import.

**Enclosures:**

"LD clause has to be confirmed without fail."  
"Payment to vendors will be made only thro E-Payment mode"

The offers should reach us 30 minutes before the time of opening of tenders. The offers will be opened at 14.30 hrs on the due date of tender in the presence of tenderers who have submitted their offer and who may like to be present for the tender opening.Late and delayed offers are liable to be rejected.

Yours faithfully,  
For BHARAT HEAVY ELECTRICALS LIMITED

  
**S. ASOKKUMAR**  
Manager  
MM/ RM/ Steel (Purchase)  
BHEL, TRICHY - 620 014.  
MANAGER / PURCHASE  
(FOSSIL BOILERS)  
Yours faithfully,  
23/09/2013

TABLE 1.1

ENCL: II

Description Beams	Section Weight	Total Depth	Flange Width	Thickness of Web	Thickness of Flange	Root radius	Area of section	Moment of Inertia		Sectional Modulus		Radius of gyration	
								X Axis	Y Axis	X Axis	Y Axis	X Axis	Y Axis
	w Kg/m	H mm	B mm	tw mm	tf mm	r mm	A cm <sup>2</sup>	Ixx cm <sup>4</sup>	Iyy cm <sup>4</sup>	Zxx cm <sup>3</sup>	Zyy cm <sup>3</sup>	rxx cm	ryy cm
UB 203 X 133 X 25	25.1	203.2	133.2	5.7	7.8	7.6	31.97	2340	307.6	230.3	46.2	8.56	3.1
UB 254 X 146 X 37	37	256	146.4	6.3	10.9	7.6	47.17	5537	570.6	432.6	78	10.83	3.48
UB 305 X 165 X 46	46.1	306.6	165.7	6.7	11.8	8.9	58.75	9899	895.7	645.7	108	12.98	3.9
UB 356 X 171 X 51	51	355	171.5	7.4	11.5	10.2	64.91	14140	968.3	796.4	112.9	14.76	3.86
UB 406 X 178 X 60	60.1	406.4	177.9	7.9	12.8	10.2	76.52	21600	1203	1063	135	16.8	3.97
IPE 450/NPB 450 X 190	77.6	450	190	9.4	14.6	21	98.8	33743	1675.9	1499.7	176.4	18.48	4.12
IPE 500/NPB 500 X 200	90.7	500	200	10.2	16	21	115.5	48199	2141.7	1927.9	241.2	20.43	4.31
IPE 600/NPB 600 X 220	122.4	600	220	12	19	24	156	92083	3387.3	3069.4	307.9	24.3	4.66
HEAA 700/WPB 700 X 300	149.9	670	300	13	17	27	190.9	142721	7673.1	4260.3	511.5	27.34	6.34
HEA 700/WPB 700 X 300	204.5	690	300	14.5	27	27	260.5	215301	12178.8	6240.6	811.9	28.75	6.65

Note:

1. UB-British Universal beam
2. NPB-Narrow Parallel Flange Beams (Equivalent to IPE-European Narrow Parallel Flange Beams)
3. WPB-Wide parallel Flange Beams (Equivalent to HE-European Wide Flange Beams)
4. Dimensional norms ref standard BS4-1:1993 for UB .For NPB ref standard EN-19-57 EN-53-63.
5. Indian suppliers may refer IS:12778

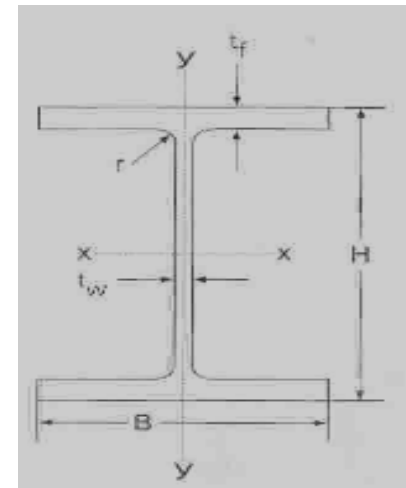

## TERMS AND CONDITIONS (Indigenous )

**1.A) QUOTATIONS:** Each tender should be sent in double cover, inner cover should be sealed with tenderer's distinctive seal and super scribed with correct tender no. Item of supply and due date of opening the outer cover should only bear the address of this office and should not have any indication that a tender is within. Two or more quotations should not be sent in one cover but the quotation against each tender should be sent separately to avoid confusion. Tender should not be addressed to any individual's name but only by designation.

b) Tenders should be free from CORRECTION AND ERASURES. Corrections if any must be attested; all amounts shall be indicated both in words as well as in figures. Where there is difference between amount quoted in words and figures, amount quoted in words shall prevail.

c) Price should be nett F.O.R. dispatching station inclusive of risk in transit and remain valid for 60 days from the due date.

d) If any sales tax is payable as extra to the quoted price it should be specifically stated in quotations along with CST & TNGST no falling which the purchaser will not be liable for payment of sales tax. Our T.N.G.S.T no 3560005 dt. 01.04.1995 CST no 239383 dt, 11.06.1991

e) No revision of prices will be entertained after tenders are opened.

f) Manufacturer's name trademark or patent no if any should be specified. Illustrative leaflets giving technical particulars are required along with quotation wherever necessary.

g) Products with I.S.I certification marks will be preferred.

h) The purchaser shall be under no obligation to accept the lowest or any other tender and shall be entitled to accept or full without assigning any reason whatsoever.

**2. SAMPLES:** Wherever possible sample should be submitted separately whether specifically requested or not so as to reach the purchaser on or before the due date of the enquiry. They should be clearly marked with the enquiry no and the date on the outside cover to facilitate identification.

**3. PACKING AND MARKING:** The supplier shall arrange for securely protecting and packing the stores to avoid loss or damages during transit.

**4. TERMS OF PAYMENT:** Payment will be made after 45 days on acceptance of materials. Wherever required by the purchaser, the successful tenderer must send the Operation and Maintenance manuals, Test Certificates, drawings, etc., for the materials ordered. These should be sent immediately after dispatch of the materials and a statement to that effect should be made in the invoice. Failure to comply with this provision will result in delay in payment of the bills. Goods dispatched either by V.P.P or by the document presented through bank will not be accepted unless agreed to by the purchaser.

The duplicate copy of the invoice meant for the transporters should accompany the material as stipulated under C.E. rules 52a and 173 c (or) 57gg. A Photostat copy of the above invoice for each Delivery Chelan should be submitted along with the original bills routed through bank or submitted directly to BHEL finance department.

**5. SECURITY DEPOSIT:** For purchases over Rs. 5000/- the successful tenderers may be requested to furnish a Bank Guarantee, Security deposit for an appropriate value as may be determined by BHEL

### **6. LIQUIDATED DAMAGES PENALTY AND INTEREST ON ADVANCES FOR DELAY IN DELIVERY:**

If the supplier fails to deliver the raw material equipment components within the period specified in the contract the purchaser shall deduct liquidated damages a sum equivalent to 0.5% of the price for each week of delay up to maximum of 15% of the price of the delayed undelivered goods. In addition to the recovery of interest at normal cash credit rate plus 2% for the unadjusted portion of the advances. If the delay in delivery of a part contributes to delay in execution of total system, LD and interest on advances will be recovered on the total contract price total advance paid.

**7. RISK PURCHASE:** Alternatively the purchaser at his option will be entitled to terminate the contract and to purchase elsewhere at the risk and cost of the seller either the whole of the goods or any part which the supplier has failed to deliver or dispatch within the time stipulated as aforesaid or if the same were not available, the best and the nearest available substitutes therefore. The supplier shall be liable for any loss, which the purchaser may sustain by reason of such risk purchases in addition to penalty at the rate mentioned in clause 6 above.

**8. PREFERENTIAL DELIVERY:** It should be noted if a contract is placed on a higher tenderer as a result of this invitation to tender in preference to the lowest acceptable offer in consideration of the earlier delivery, the seller will be liable to pay to the purchaser the difference between the contract rate and that of the lowest acceptable tender on the basis of final price F.O.R destination, including all eliminates of freights. Sales tax, duties and other incidents, incidental in case of failure to complete suppliers in terms of such contract within the date of delivery specified in the tender and incorporated in the contract.

**9. MODVAT CREDIT:** If any Excise Duty is payable, the chapter head / Sub -head reference and the rate of the duty should be quoted. If the tender is availing MODVAT credit for this input material, the effect of Proforma credit should be passed on to the purchaser. Tenderer under "MODVAT" shall be preferred.

**10. PURCHASE:** Preference will be given to CPSUS as per. Government guidelines.

**11. GENERAL:** The purchaser reserves the right to split up the tender and place order for individual terms with different tenderers and also increase or decrease the quantity.

Any other conditions which might have been quoted by the seller and are in contravention to the terms prescribed in the order and which have not been specifically accepted in by purchaser will not be applicable to the contract.

## **TERMS AND CONDITIONS (IMPORT SUPPLIERS)**

### **1. OFFER:**

Offer in ENGLISH LANGUAGE AND IN TRIPLICATE in a SEALED COVER SUPERSCRIBING the enquiry number and the due date shall be submitted addressed to:

**THE MANAGER / PURCHASE / FB  
BHARAT HEAVY ELECTRICALS LIMITED  
HIGH PRESSURE BOILER PLANT  
THIRUCHIRAPPALLI – 620 014  
TAMIL NADU  
INDIA**

offers should be firm for net FOB Nearest Sea Port price and C&F Chennai port, indicating the shipping specifications and the earliest delivery in respect of offers from overseas suppliers. Offers from indigenous sources shall be firm for FOR TIRUCHIRAPPALLI

### **2. DOCUMENTS:**

(1) offers should be accompanied by detailed technical literature, catalogue and detailed dimensional drawings in ENGLISH and in TRIPLICATE, or otherwise, the offers will not be considered.

(2) in case overseas suppliers route their offer through their accredited selling agents, a letter of authority should be furnished mentioning the name and address of their selling agents, who are authorized to bid, negotiate and conclude a contract on their behalf.

### **3. AGENCY COMMISSION:**

(1) in respect of offers from overseas suppliers, agency commission, if any, payable to their agents in India, shall invariably be shown separately in the Performa invoice and this will be paid by us in India, in Indian rupees, on satisfactory completion of the contract.

(2) if overseas principal has any tie-up with any third party in respect of agency commission it should be declared while submitting offers.

(3) copies of current agency agreement / authorization letter in respect of agency commission shall be furnished along with offer, if not made available earlier.

(4) for calculation of rupee equivalent of agency commission, exchange rate as prevailing on the date of order will be taken.

### **4. SPARES:**

The tenderer should quote separately for spares that are required for two years trouble free operation. The spares offer should accompany the offer of main equipment, otherwise the quotations will be overlooked.

### **5. VALIDITY:**

The offers for main equipment and spares shall be kept open for acceptance for 120 days (one hundred and twenty days) from the date of opening of the tender.

### **6. TEST CERTIFICATES, OPERATING AND MAINTENANCE MANUALS:**

The tenderer shall clearly mention in their offer, that test certificates and operation and maintenance manuals, etc., as called for in the technical specification, in the required number of copies will be provided at no extra cost. If any amount is payable as extra, the same shall be indicated separately in the offer.

### **7. TERMS OF PAYMENT:**

In the event of an order the purchaser will arrange for an irrevocable letter of credit against presentation of documents. Under no circumstances confirmed and irrevocable letter of credit will be established by the purchaser.

### **8. GENERAL:**

(1) preference will be given to suitable indigenous or ex-stock in ported offers, failing which imported offers from incoming consignment against the indigenous supplies "stock and license" will be accepted, if "stock and sale license" is not available with the indigenous suppliers, the same shall be indicated in their offer.

(2) bank guarantee: the supplier in the event of an order, should furnish a bank guarantee from an approved bank at no extra cost in a Performa which will be supplied to the supplier, along with the order, for an amount equivalent to 10% of the value of the contract. The bank guarantee should remain in full force and effect during the period that would be taken for successful completion of the contract and shall continue to be enforceable till 12 months from the date of receipt of consignment at purchaser's site or 18 months from the date of last shipment at the port of delivery whichever is earlier.

### **9. LD/ PENALTY AND INTEREST ON ADVANCES FOR DELAY IN DELIVERY:**

" if the supplier fails to delivery the raw materials / equipment / components within the period specified in the contract the purchaser shall deduct liquidated damages a sum equivalent to 0.5% of the price for each week of delay upto a maximum of 15% of the price of the delayed / undelivered goods, in addition to the recovery of interest at normal cash credit rate plus 2% for the unadjusted portion of the advances. If the delay in delivery of a part contributes to delay in execution of total system, LD and interest on advances will be recovered on the total contract price / total advance paid"

BHEL recently received guidelines from Govt. Of India and Central Vigilance Commission and we have been asked to comply with the guidelines with regard to dealings with Indian Agent/Foreign Agent of Foreign Suppliers.

---

## **1. Mandatory submission of an Agency Agreement**

- 1.1 It shall be incumbent on the Indian agent and the foreign principal to adhere to the relevant guidelines of Government of India, issued from time to time.
- 1.2 The Agency Agreement should specify the precise relationship between the foreign OEM/foreign principal and their Indian agent and their mutual interest in the business. All services to be rendered by agent/associate, whether of general nature or in relation to the particular contract, must be clearly stated by the foreign supplier/Indian agent. Any payment, which the agent or associate receives in India or abroad from the OEM, whether as commission or as a general retainer fee should be brought on record in the Agreement and be made explicit in order to ensure compliance to laws of the country.
- 1.3 In the absence of any agency agreement, BHEL shall not deal with any Indian agent (authorized representatives / associate / consultant, or by whatever name called) and shall deal directly with the foreign principal only for all correspondence and business purposes.
- 1.4 Agents will file an authenticated Photostat copy duly attested by a Notary Public / Original certificate of the Principal confirming the agency agreement and giving the status being enjoyed by the agent and the commission / remuneration / salary / retainer ship being paid by the principal to the agent.
- 1.5 Wherever the Indian representatives have communicated on behalf of their principals and the foreign parties have stated that they are not paying any commission to the Indian agents, and the Indian representative is working on the basis of salary or as retainer, a written declaration to this effect should be submitted by the Foreign Principal.

## **2. Disclosure of particulars of agents / representatives in India**

### ***2.1 Tenderers of Foreign nationality shall furnish the following details:***

2.1.1 The Bidder(s) / Contractor(s) of foreign origin shall disclose the name and address of the agents / representatives in India if any and the extent of authorization and authority given to commit the Principals. In case the agent / representative be a foreign Company, it shall be confirmed whether it is existing Company and details of the same shall be furnished.

2.1.2 The amount of commission / remuneration included in the quoted price(s) for such agents / representatives in India.

2.1.3 Confirmation of the Tenderer that the commission / remuneration, if any, payable to his agents / representatives in India, paid in Indian Rupees only.

**2.2 Tenderers of Indian Nationality shall furnish the following details:**

2.2.1 The Bidder(s) / Contractor(s) of Indian Nationality shall furnish the name and address of the foreign principals, if any, indicating their nationality as well as their status, i.e. whether manufacturer or agents of manufacturer holding the Letter of Authority of the Principal specifically authorizing the agent to make an offer in India in response to tender either directly or through the agents / representatives.

2.2.2 The amount of commission / remuneration included in the price(s) quoted by the Tenderer for himself.

2.2.3 Confirmation of the foreign principals of the Tenderer that the commission / remuneration, if any, reserved for the Tenderer in the quoted price(s), paid in India in equivalent Indian Rupees on satisfactory completion of the Project or supplies of Stores and Spares in case of operation items.

2.3 Failure to furnish correct and detailed information as called for in paragraph 2.1 & 2.2 above will render the concerned tender liable to rejection or in the event of a contract materializing, the same liable to termination by BHEL Besides this there would be a penalty of banning business dealings with BHEL or damage or payment of a named sum.

Please furnish the above information immediately

	<b>Annexure-II</b> <b>GUIDELINES TO INDIAN SUPPLIERS</b> <b>FOR FILLING-UP</b> <b>SUPPLIER REGISTRATION FORM</b>	Document No.	AA:MM:SR:01
		Revision No.	01amdt.01
		Page No.	I of II

- Registration Form may be obtained from BHEL website [www.bhel.com](http://www.bhel.com).
- Any clarification with respect to procedure for registration may be obtained from the Supplier Development Cell of respective BHEL unit.

- The Supplier Registration Form has four parts:

Part A	Organisational Information	Form no. SRF(I)01 – page 1 to 10
Part B	Quality System	Form no. SRF(I)01 - page 11 to 12
Part C	Technical Competence	Form no. SRF(I)01 page 13 (if sent by BHEL)
Part D	Score Sheet (to be filled by BHEL)	Form no. SRF(I)01 page 14 to 17

The set of formats to be filled by different category of suppliers is as follows:

Sl.No	Supplier Category	Formats
1.	Indian Suppliers ( manufacturers )	- Organisational Information - Quality System - Technical Competence
2.	Indian Stockist/ Trader/ Distributor/ Dealer/ Authorised Agent/ Channel partner/ Indian Sales office or Subsidiary of registered foreign principal	- Organisational Information SRF(I)01- Part A (page 1 to 10 except Sl. No. 5.1, 5.2, 6.6, 6.7, 7 & 8)

- All columns are to be filled up properly in the space provided for. Wherever it is not applicable, please mention "Not Applicable". The form is to be signed by the authorised signatory.
- A separate sheet may be attached if the space provided is insufficient or additional information is to be given. Please put proper identification tag on the separately attached sheet.
- Any information / clarification required by BHEL during evaluation must be given expeditiously.
- Please ensure that all required enclosures are attached with the filled up Supplier Registration Form and list of enclosures is given as required.
- Incomplete forms will be rejected.
- Please note that if you are registered and participate in Tender process and qualify to get order from BHEL, your performance based on Quality of your product, delivery performance and service rendered will be evaluated inline with Chapter VI.
- Please fill up the check- list given below and send along with the Supplier Registration Forms to BHEL.

	<b>Annexure-II</b> <b>Check List for Indian Supplier</b> <b>Registration Form</b>	Document No.	AA:MM:SR:01
		Revision No.	01amdt.01
		Page No.	II of II

Sl.No.	Check-Point	Yes/No
1.	Information against all points under “Organizational Information” (Part-A) has been given.	
2.	All enclosures and supporting documents have been enclosed.	
3.	Summary list of enclosures has been furnished as per S.N.10 of Organisational Information form no. SRF (I) 01 & S.N 12 of Quality system form no. SRF (I) 01.	
4.	Are you an ISO 9001 accredited supplier?	
5.	If yes, have you enclosed "Table of Contents" of your Quality Manual and copy of ISO 9001 accreditation certificate?	
6.	Have you filled up Quality System format given in Part B?	
7.	Technical requirements, specifications, drawings, standards have been received from BHEL before filling up Technical Competence, Part C.	
8.	All the parts of the form & enclosures have been signed by Authorised Signatory.	
9.	Have you attached EFT details. (Certified by the bank)	

Date :

Signature & seal

(Authorised Signatory)

Note: This check list is to be attached with the filled up Supplier Registration Form.

**BHARAT HEAVY ELECTRICALS LIMITED  
SUPPLIER REGISTRATION FORM**

FORM NO. SRF(I) 01 (INDIAN SUPPLIER)

**ANNEXURE-II**  
Page 1 of 17 amdt.01

**PART- A : ORGANISATIONAL SOUNDNESS**

ALL COLUMNS SHOULD BE PROPERLY FILLED IN THE SPACE PROVIDED FOR, WHEREVER IT IS NOT APPLICABLE, PLEASE WRITE "NOT APPLICABLE". INCOMPLETE OR INCORRECT FORMS MAY NOT BE CONSIDERED. **PLEASE ATTACH SEPARATE SHEET, IF SPACE AVAILABLE IS INADEQUATE. INFORMATION WITH \* MARKS IS SCOREABLE.**

**ALL THE PAGES OF THE FORM ARE TO BE SIGNED ALONGWITH SEAL BY THE AUTHORISED SIGNATORY**

<b>ORGANISATIONAL INFORMATION</b>			
<b>NAME AND CORRESPONDENCE ADDRESS OF THE SUPPLIER SEEKING REGISTRATION :-</b>			
<b>1.0 PRODUCTS / SYSTEMS / SERVICES FOR WHICH REGISTRATION IS APPLIED FOR :</b>			
SL. NO.	DESCRIPTION	SIZE & RANGE	MFG. STD/ IS / DIN /BS ETC.
<b>SUPPLIER'S AUTHORISED SIGNATORY</b>		<b>BHEL CERTIFIED ASSESSOR</b>	

**BHARAT HEAVY ELECTRICALS LIMITED  
SUPPLIER REGISTRATION FORM**

**FORM NO. SRF(I) 01 (INDIAN SUPPLIER)**

**ANNEXURE-II**

Page 2 of 17

**ORGANISATIONAL INFORMATION**

**2.0 GENERAL INFORMATION :**

2.1 NAME OF THE WORKS/DIVISION :

ADDRESS :

E - Mail :

TELEPHONE : Landline

Mobile

FAX :

2.2 NAME OF CHIEF EXECUTIVE /  
PROPRIETOR / PARTNER & ADDRESS :

2.3 DETAILS OF AUTHORISED SIGNATORY FOR SEEKING CLARIFICATION :

NAME :

DESIGNATION :

E - Mail :

TELEPHONE : Landline

Mobile

FAX :

SUPPLIER'S AUTHORISED SIGNATORY

BHEL CERTIFIED ASSESSOR

**BHARAT HEAVY ELECTRICALS LIMITED  
SUPPLIER REGISTRATION FORM**

**FORM NO. SRF(I) 01 (INDIAN SUPPLIER)**

**ANNEXURE-II**  
Page 3 of 17 amdt.01

**ORGANISATIONAL INFORMATION**

**3.0 OWNERSHIP INFORMATION : DOCUMENTS TO BE FURNISHED**

3.1 GOVT. OF INDIA UNDERTAKING:

OR

STATE GOVT. UNDERTAKING :

OR

LIMITED COMPANY, :

MEMORANDUM AND  
ARTICLES OF ASSOCIATION

OR

PRIVATE COMPANY :

MEMORANDUM AND  
ARTICLES OF ASSOCIATION

OR

CO-OPERATIVE SOCIETY, :

SOCIETY RULES AND  
BYE LAWS

OR

PARTNERSHIP FIRM, :

PARTNERSHIP DEED

OR

PROPRIETORSHIP, :

PROFESSION TAX REGN.  
AND MUNICIPAL REGN.

ANY OTHER (SPECIFY) :

3.2 NATURE OF BUSINESS :

(MANUFACTURING UNIT/  
ENGG CONSULTANT/ EPC CONTRACTOR)

(AGENTS/ DISTRIBUTORS/STOCKISTS/DEALERS/  
TRADERS/ INDIAN SUBSIDIARY/ CHANNEL PARTNER – attach authorization  
certificate of principal)

3.3 YEAR OF ESTABLISHMENT :

\* 3.4 YEAR OF COMMENCEMENT OF BUSINESS :

SUPPLIER'S AUTHORISED SIGNATORY

BHEL CERTIFIED ASSESSOR

**BHARAT HEAVY ELECTRICALS LIMITED  
SUPPLIER REGISTRATION FORM**

FORM NO. SRF(I) 01 (INDIAN SUPPLIER)

ANNEXURE-II

Page 4 of 17

**ORGANISATIONAL INFORMATION**

**4.0 REGISTRATION PARTICULARS**

( FURNISH DETAILS AND ENCLOSE COPY OF CERTIFICATE FOR THE FOLLOWING)

4.1 PERMANENT ACCOUNT NO :  
4.2 CENTRAL SALES TAX REGN NUMBER :  
4.3 STATE SALES TAX / TIN NUMBER :  
4.4 EXCISE DUTY REGN NUMBER :  
4.5 EXCISE CONTROL CODE NUMBER :  
4.6 SERVICE TAX REGN NUMBER :  
4.7 CATEGORY AS PER MSMED ACT : MICRO/ SMALL/ MEDIUM  
REGN NO. :  
VALID UPTO :  
(Attach Certificate)

**5.0 TOTAL ORGANISATIONAL STRENGTH : (ATTACH ORGANISATION CHART)**

	GRADUATE	DIPLOMA	SKILLED	NON-SKILLED
ENGINEERING :				
MANUFACTURING :				
QUALITY :				
COMMERCIAL / SERVICE AFTER SALES :				
OTHERS :				
TOTAL :				
* 5.1 POWER BACKUP : (GIVE DETAILS)	YES/ NO			

\* 5.2 DOES THE COMPANY SELL ITS PRODUCT DIRECTLY : YES/ NO

SUPPLIER'S AUTHORISED SIGNATORY

BHEL CERTIFIED ASSESSOR

**BHARAT HEAVY ELECTRICALS LIMITED  
SUPPLIER REGISTRATION FORM**

**FORM NO. SRF(I) 01 (INDIAN SUPPLIER)**

**ANNEXURE-II**

Page 5 of 17

**ORGANISATIONAL INFORMATION**

**6.0 OTHER PARTICULARS :**

( FURNISH DETAILS AND ENCLOSE DOCUMENTARY EVIDENCE/ COPY OF CERTIFICATE FOR THE FOLLOWING)

\* 6.1 IF THE COMPANY IS ALREADY REGISTERED WITH ANY OF BHEL UNITS, GIVE :

6.1.1. BHEL UNIT'S NAME :

6.1.2. SUPPLIER REGN. CODE NO. :

6.1.3. ITEMS FOR WHICH REGISTERED & THEIR SPECIFICATION  
( ENCLOSE PROOF OF SUCCESSFUL EXECUTION OF  
ONE OR MORE PURCHASE ORDERS ) :

\* 6.2 IS THE COMPANY APPROVED BY  
ASME / NTPC / NPC / EIL / DGS&D / RAILWAYS /  
IBR / LLOYDS ETC FOR INTENDED  
MATERIAL CATEGORY? : YES / NO  
(ENCLOSE DOCUMENTARY EVIDENCE)

\* 6.3 IS THE COMPANY ISO 9001 APPROVED? : YES / NO  
(ENCLOSE CERTIFICATE & TOC OF QUALITY SYSTEM) :

\* 6.4 IS THE COMPANY AN ISO 14000 APPROVED? : YES / NO  
(ENCLOSE CERTIFICATE) :

\* 6.5 IS THE COMPANY OHSAS - 18000 APPROVED?: YES / NO  
(ENCLOSE CERTIFICATE)

\* 6.6 TECHNICAL COLLABORATOR :  
(FOREIGN OR INDIGENOUS)  
(ENCLOSE DOCUMENTARY EVIDENCE)

\* 6.7 R&D SET UP

6.8 DIRECTORS / PARTNERS, IF RELATED TO ANY  
BHEL EMPLOYEE.  
NAME :  
STAFE NO. :  
DESIGNATION :  
Unit & DEPARTMENT :  
RELATIONSHIP :

SUPPLIER'S AUTHORISED SIGNATORY

BHEL CERTIFIED ASSESSOR

**BHARAT HEAVY ELECTRICALS LIMITED  
SUPPLIER REGISTRATION FORM**

**FORM NO. SRF(I) 01 (INDIAN SUPPLIER)**

**ANNEXURE-II**

Page 6 of 17

**ORGANISATIONAL INFORMATION**

6.9 IF ANY EX-BHEL PERSONNEL IS EMPLOYED BY THE COMPANY, MENTION HIS / HER DETAILS OF LAST POSTING.

NAME :  
STAFF NO. :  
DESIGNATION :  
UNIT & DEPARTMENT :  
DATE OF LEAVING SERVICE :

6.10 COMPANY'S WEEKLY HOLIDAYS :

WORKS                      OFFICE

6.11 EXPERIENCE LIST:

(ATTACH LIST OF PRESENT CUSTOMERS WITH NAME & ADDRESS FOR OFFERED / SIMILAR TYPE & SIZE OF ITEM / EQUIPMENT FOR WHICH REGISTRATION HAS BEEN SOUGHT AND WITH WHOM YOU HAVE CONTINUOUS BUSINESS SINCE LAST THREE YEARS . ALSO ATTACH PERFORMANCE CERTIFICATES ISSUED BY ANY TWO CLIENTS FOR SUCCESSFUL EXECUTION OF THE CONTRACTS FOR LAST TWO YEARS- FOR PEM)

\*6.12 DETAILS OF PENDING LEGAL ISSUES ON CONTRACTUAL ASPECTS WITH CUSTOMER , IF ANY

6.13 The following information of Bank Account of the Company, duly endorsed by the Bank (required for Electronic Fund Transfer –EFT/RTGS) is to be submitted

1. Name of the Company
2. Name of Bank
3. Name of Bank Branch
4. City/Place
5. Account Number
6. Account type
7. IFSC code of the Bank Branch
8. MICR Code of the Bank Branch
9. Details of other Bankers (for reference purpose only)

NOTE :

(i) Suppliers who have already submitted the above information are requested to submit a copy of the same.

SUPPLIER'S AUTHORISED SIGNATORY

BHEL CERTIFIED ASSESSOR

**BHARAT HEAVY ELECTRICALS LIMITED  
SUPPLIER REGISTRATION FORM**

FORM NO. SRF(I) 01 (INDIAN SUPPLIER)

ANNEXURE-II

Page 7 of 17

**ORGANISATIONAL INFORMATION**

**7.0 MANUFACTURING FACILITIES:**

**\*7.1 LIST OF MANUFACTURING FACILITIES/EQUIPMENTS (INCLUDING MATERIAL HANDLING FACILITY)**

SL. NO	DESCRIPTION OF MACHINE/EQUIPMENT	QUANTITY	MAKE & YEAR OF INSTALLATION	REMARKS

IN CASE OF SPACE LIMITATION, PLEASE ENCLOSE ANNEXURE / CATALOGUE WITH TAG

**\* 7.2 IF IN-HOUSE MFG FACILITIES NOT AVAILABLE, INFORM SOURCE OF MFG. DETAILS ALONGWITH THEIR FACILITIES & EXPERIENCE**

SL. NO	PROCESS OUTSOURCED	NAME OF THE COMPANY	DESCRIPTION OF MACHINE / EQUIPMENT	REMARKS

IN CASE OF SPACE LIMITATION ENCLOSE ANNEXURE / CATALOGUE WITH TAG

**\* 7.3 RATIO OF OUTSOURCED COST TO TOTAL PRODUCTION VALUE:**

SUPPLIER'S AUTHORISED SIGNATORY

BHEL CERTIFIED ASSESSOR

**BHARAT HEAVY ELECTRICALS LIMITED  
SUPPLIER REGISTRATION FORM**

FORM NO. SRF(I) 01 (INDIAN SUPPLIER)

ANNEXURE-II

Page 8 of 17

**ORGANISATIONAL INFORMATION**

**8.0 INSPECTION & TESTING FACILITIES:**

**\* 8.1 LIST OF INSPECTION & TESTING FACILITIES / EQUIPMENT**

SL. NO	DESCRIPTION OF FACILITY/ EQUIPMENT & CAPACITY	NOS.	MAKE & YEAR OF MANUFACTURING	LAST DATE OF CALIBERATION

IN CASE OF SPACE LIMITATION ENCLOSE ANNEXURE / CATALOGUE WITH TAG

**\* 8.2 IF IN-HOUSE TESTING FACILITIES NOT AVAILABLE, INDICATE SOURCE OF TESTING ALONGWITH THEIR FACILITIES & EXPERIENCE**

SL. NO	TEST	SOURCE OF TESTING	DESCRIPTION OF FACILITY/ EQUIPMENT & CAPACITY	APPROVAL OF EQUIPMENT/ PROCESS/PERSONNEL QUALIFICATION

IN CASE OF SPACE LIMITATION ENCLOSE ANNEXURE / CATALOGUE WITH TAG

**Note:**

**In case of outsourcing of major testing such as NDT, Electrical & Mechanical Testing, no marks will be awarded. However, material composition testing by chemical method from recognized laboratory shall not attract negative marking**

SUPPLIER'S AUTHORISED SIGNATORY

BHEL CERTIFIED ASSESSOR

# BHARAT HEAVY ELECTRICALS LIMITED SUPPLIER REGISTRATION FORM

FORM NO. SRF(I) 01 (INDIAN SUPPLIER)

ANNEXURE-II

Page 9 of 17

ORGANISATIONAL INFORMATION					
FINANCIAL INFORMATION FOR THE PREVIOUS FOUR YEARS					
9.0	Parameter	Year 1	Year 2	Year 3	Year 4
		(Years in ascending order, Money value in Rs. Lakhs )			
* 9.1	NET WORTH (Share Capital +Reserves)				
	Growth over previous year (%)	-----			
9.2	LONG TERM DEBT / LOAN				
* 9.3	DEBT EQUITY RATIO				
	$\frac{\text{Long term Debt (4.2)}}{\text{Net worth (4.1)}}$				
9.4	INVESTMENT IN: Land & Building				
	Plant & Machinery				
	Other Fixed Assets				
9.5*	NET CURRENT ASSETS				
	1 a) Cash on hand				
	b) Account receivable				
	c) Inventories				
	Total				
	CURRENT LIABILITY				
	2 a) Sundry creditors				
	b) Interest accrued but not due				
	c) Other liabilities				
	Total				
3	* QUICK RATIO				
	$\frac{\text{CA - INVENT. } \{9.5(1)-9.5(1)c\}}{\text{Current liability } \{9.5 (2)\}}$				
* 9.6	SALES				
	Growth over previous year (%)	-----			
* 9.7	PROFIT BEFORE TAX				
	Growth over previous year (%)	-----			
* 9.8	Whether the supplier has been referred to BIFR / NCLT / any other Govt agency ( If YES , enclose details)				YES / NO
* 9.9	Whether the supplier is a potential sick company.( If YES , enclose details)				YES / NO
<p>NOTE: 1. Copies of annual accounts (Balance Sheet) for the last four years (or from date of incorporation which ever is less) along with audit report are to be submitted. The above details shall be highlighted in the Balance Sheet.</p> <p>2. Status of Tax assessments done under various laws (Income Tax, VAT/Sales Tax, Excise &amp; Service Tax, Custom) and details of disputes pending, if any, with these authorities to be submitted.</p>					
SUPPLIER'S AUTHORISED SIGNATORY			BHEL CERTIFIED ASSESSOR		

# BHARAT HEAVY ELECTRICALS LIMITED SUPPLIER REGISTRATION FORM

FORM NO. SRF(I) 01 (INDIAN SUPPLIER)

ANNEXURE-II

Page 10 of 17

## ORGANISATIONAL INFORMATION

**10. LIST OF ENCLOSURES** (Tags to be put on enclosures) :

- (i) MEMORANDUM AND ARTICLES OF ASSOCIATION / SOCIETY RULES AND BYE LAWS / PARTNERSHIP DEED/ PROFESSION TAX REGN & MUNICIPAL REGN. : YES / NO
- (ii) Copy of certificate of following:-
- PERMANENT ACCOUNT NO : YES / NO
  - CENTRAL SALES TAX REGN NUMBER : YES / NO
  - STATE SALES TAX / TIN NUMBER : YES / NO
  - EXCISE DUTY REGN NUMBER : YES / NO
  - EXCISE CONTROL CODE NUMBER : YES / NO
  - SERVICE TAX REGN NUMBER : YES / NO
  - REGN NUMBER OF CATEGORY AS PER MSMED ACT : YES / NO
- (iii) ORGANISATION CHART : YES / NO
- (iv) If registered with any other BHEL Unit,
- LETTER OF REGISTRATION WITH BHEL UNIT : YES / NO
  - PROOF OF SUCCESSFUL EXECUTION OF ONE OR MORE PURCHASE ORDERS : YES / NO
- (v) Letter of approval from ASME / NTPC / NPC / EIL / DGS&D / RAILWAYS / IBR / LLOYDS ETC : YES / NO
- (vi) Accreditation certificate for
- ISO: 9001 : YES / NO
  - TOC of Quality System Manual : YES / NO
  - ISO : 14000 : YES / NO
  - OHSAS , ISO 18000 : YES / NO
- (vii) Letter regarding technical collaboration : YES / NO
- (viii) Experience List / Performance certificate : YES / NO
- (ix) Balance Sheet for the last four years along with audit Report : YES / NO
- (x) Principal's authorization in case of dealers/ agents : YES / NO
- (xi) EFT Bank's certificate : YES / NO

I /WE GIVE THE UNDERTAKING THAT BHEL DRAWINGS & SPECIFICATIONs SHALL NOT BE USED IN ANY WAY DETRIMENTAL TO THE INTEREST OF BHEL AND/ OR FOR SUPPLY OF ANY MATERIAL, PRODUCT OR SERVICES DIRECTLY OR INDIRECTLY TO ANY OTHER CUSTOMER.

Maximum Marks = 50

Negative Marks = -13

Minimum Qualifying marks = 30

SUPPLIER'S AUTHORISED SIGNATORY

BHEL CERTIFIED ASSESSOR

**BHARAT HEAVY ELECTRICALS LIMITED  
SUPPLIER REGISTRATION FORM**

**FORM NO. SRF(I) 01 (INDIAN SUPPLIER)**

**ANNEXURE-II**

Page 11 of 17

**FORM NO. SRF(I) 01**

**Part B (QUALITY SYSTEM):**

Sl. No	PARAMETERS	SYSTEM IN EFFECT (Tick if exists & provide evidences if ticked in written procedure)		RECORDS (Tick if available & submit evidences)	REMARKS
		Written Procedure	Practice		
1*	Incoming Material Control System				Furnish a copy of system and organization.
2*	In process control				Furnish at least one work instruction & record of process control parameter
3*	Manufacturing / Testing Procedure Qualification				Procedure Qualification specification may be submitted
4*	Personnel qualification for 3 above.				Record of Personnel qualification (PQR) to be submitted
5*	Calibration system				Submit list of instrument & their calibration status
6*	System of Identification & Traceability of materials, tools, jigs, fixtures & processed components, etc.				Copy of procedure to be submitted
7*	System of Storage, Preservation , Painting & packing				Copy of procedure to be submitted
8*	System of NCR disposition & corrective preventive action				Two copies of NCR & CAPA
9*	Customer complaints handling system				Submit list of customer complaints & status for the last three years
10*	Safety measures				Submit copy of safety system & Record of accidents for last three years
11	Any other quality initiative				

SUPPLIER'S AUTHORISED SIGNATORY

BHEL CERTIFIED ASSESSOR

**BHARAT HEAVY ELECTRICALS LIMITED  
SUPPLIER REGISTRATION FORM**

**FORM NO. SRF(I) 01 (INDIAN SUPPLIER)**

**ANNEXURE-II**

Page 12 of 17

**FORM NO. SRF(I) 01**

**Part B (QUALITY SYSTEM):**

**12. LIST OF ENCLOSURES**

- (i) Copy of system of control incoming materials and organization chart
- (ii) Copy of at least one process control work instruction
- (iii) Record of process control parameter
- (iv) Copy of at least one Procedure Qualification specification
- (v) Record of Personnel qualification (PQR)
- (vi) List of instrument & their calibration status
- (vii) Copy of procedure for Identification & Traceability of materials, tools, jigs, fixtures & processed components, etc.
- (viii) Copy of procedure for Storage/ preservation/ painting & packing
- (ix) Copies of two NCRs and their CAPA.
- (x) List of customer complaints & status for the last three years
- (xi) Copy of safety system
- (xii) Record of accidents for last three years

Maximum Marks = 25

Minimum Qualifying marks = 15

SUPPLIER'S AUTHORISED SIGNATORY

BHEL CERTIFIED ASSESSOR

# BHARAT HEAVY ELECTRICALS LIMITED SUPPLIER REGISTRATION FORM

FORM NO. SRF(I) 01 (INDIAN SUPPLIER)

ANNEXURE-II

Page 13 of 17 amdt.01

## FORM NO. SRF(I)01

### Part C : TECHNICAL COMPETENCE

Technical competence shall be evaluated in two parts viz. common competence and product/material category specific competence.

#### **(i) COMMON TECHNICAL COMPETENCE (Max Marks: 10)**

TECHNICAL COMPETENCE ( where <b>design specification</b> is given by BHEL )	MARKING RANGE	SUPPLIER RESPONSE (ALONG WITH SUPPORTING DOCUMENTS)	MARKS BY BHEL
1. Supplier understands the product specification.	(0-3)		
2. Supplier understands the inspection requirements.	(0-2)		
3. Supplier has process capability to achieve the product specification/dimensional requirement.	(0-3)		
4. Supplier has experienced manpower to carry out the job.	(0-2)		
<b>TOTAL MARKS OUT OF POSSIBLE (10) = ---</b>			

**OR**

TECHNICAL COMPETENCE ( where <b>performance specification</b> is given by BHEL )	MARKING RANGE	PROCEDURE		SYSTEM IN EFFECT		RECORDS	
		SUPPLIER RESPONSE (ALONG WITH SUPPORTING DOCUMENTS)	MARKS BY BHEL	SUPPLIER RESPONSE (ALONG WITH SUPPORTING DOCUMENTS)	MARKS BY BHEL	SUPPLIER RESPONSE (ALONG WITH SUPPORTING DOCUMENTS)	MARKS BY BHEL
1. Design capability	(0-3)						
2. Adequacy of quality assurance plan	(0-2)						
3. Process capability for components	(0-3)						
4. Adequate of testing	(0-2)						
<b>TOTAL MARKS OUT OF POSSIBLE (10)</b>							
<b>Average of Total (Total/3) = -----</b>							

#### **(ii) PRODUCT/ MATERIAL CATEGORY SPECIFIC TECHNICAL COMPETENCE**

**(Max Marks: 15)**

Unit MISCC to structure the parameters to be considered for the technical competence depending on material category. The score of individual parameter selected is to be decided by MISCC. MISCC shall identify the requirement of enclosures to be furnished by supplier  
Product:

Sl. No	Material category	Tech Parameter	Supplier's response	Remarks

To be filled up only on receipt of technical requirements/ specification, drawings, standards from BHEL and to be sent to BHEL for further scrutiny. Enclose documentary evidence where ever required.

#### **LIST OF ENCLOSURES:**

Maximum Marks = 25

Minimum Qualifying marks = 15

SUPPLIER'S AUTHORISED SIGNATORY

BHEL CERTIFIED ASSESSOR

# BHARAT HEAVY ELECTRICALS LIMITED SUPPLIER REGISTRATION FORM

FORM NO. SRF(I) 01 (INDIAN SUPPLIER)

ANNEXURE-II

Page 14 of 17 amdt.01

## Part D : SCORE SHEET

### 1. ORGANISATIONAL SOUNDNESS (for Manufacturers):

S.N.	PARAMETER	CRITERIA	Maxm. Marks	Marks Awarded
1.	Whether all <b>relevant information</b> like ownership, PAN no., sales tax no., excise duty no., etc. submitted	Yes: 2 No: 0	2	
2.	3.4 YEAR OF COMMENCEMENT OF BUSINESS	More than 5 years : 2 1-5 years : 1 Less than 1 year : 0	2	
3.	5.1 POWER BACKUP	Yes : 1 No : 0	1	
4.	5.2 DOES THE COMPANY SELL ITS PRODUCT DIRECTLY	Yes : 1 No : 0	1	
5.	6.1 REGISTERED WITH ANY OF BHEL UNITS	Yes (same item) : 2 Yes (another item) : 1 No : 0	2	
6.	6.2 APPROVAL BY ASME/ NTPC/ NPC/ EIL/ DGS&D/ RAILWAYS/ IBR/ LLOYDS ETC	Yes : 2 No : 0	2	
7.	6.3 ISO 9001 ACCREDITATION	Yes : 3 No : 0	3	
8.	6.4 ISO 14000 ACCREDITATION	Yes : 1 No : 0	1	
9.	6.5 OHSAS - 18000 ACCREDITATION	Yes : 1 No : 0	1	
10.	6.6 TECHNICAL COLLABORATOR : (FOREIGN OR INDIGENOUS)	Yes : 1 No : 0	1	
11.	6.7 R & D SET UP	Yes : 1 No : 0	1	
12.	6.12 PENDING LEGAL ISSUES ON TECHNO – COMMERCIAL ASPECTS WITH CUSTOMER	Yes : -5 No : 0	0	
13.	7.1 & 7.2 MANUFACTURING FACILITIES INCLUDING OUTSOURCING	Adequate : 3 Substantial : 2 Inadequate : 0	3	
14.	7.3 RATIO OF OUTSOURCED COST TO TOTAL PRODUCTION VALUE	Less than 10% : 2 10 to 30 % : 1 More than 30% : 0	2	
15.	8.1 INSPECTION & TESTING FACILITIES	Adequate : 2 Substantial : 1 Inadequate : 0	2	
16.	8.2 OUTSOURCING OF MAJOR TESTING FACILITY (Refer Note)	Yes : 0 No : 1	1	
	<b>TOTAL</b>		<b>25</b>	

### 1. ORGANISATIONAL SOUNDNESS (for Indian Stockist/ Trader/ Distributor/ Dealer/ Authorised Agent/ Channel partner/ Indian Sales office or Subsidiary of registered foreign principal):

S.N.	PARAMETER	CRITERIA	Maxm. Marks	Marks Awarded
1.	Whether all <b>relevant information</b> like ownership, PAN no., sales tax no., etc. submitted ( <b>clause 6.0 of chapter V to be referred in this regard</b> )	Yes: 7 No: 0	7	
2.	3.4 YEAR OF COMMENCEMENT OF BUSINESS	More than 3 years : 2 1-3 years : 1 Less than 1 year : 0	2	
3.	6.1 REGISTERED WITH ANY OF BHEL UNITS	Yes (same item) : 2 Yes (another item) : 1 No : 0	2	
4.	6.2 APPROVAL BY ASME/ NTPC/ NPC/ EIL/ DGS&D/ RAILWAYS/ IBR/ LLOYDS ETC	Yes : 2 No : 0	2	
5.	6.3 ISO 9001 ACCREDITATION	Yes : 2 No : 0	2	
6.	6.12 PENDING LEGAL ISSUES ON TECHNO – COMMERCIAL ASPECTS WITH CUSTOMER	Yes : -5 No : 0	0	

**BHEL CERTIFIED ASSESSOR**

# BHARAT HEAVY ELECTRICALS LIMITED SUPPLIER REGISTRATION FORM

FORM NO. SRF(I) 01 (INDIAN SUPPLIER)

ANNEXURE-II  
Page 15 of 17 amdt.01

## Part D: SCORE SHEET

### 2. FINANCIAL INFORMATION (for Manufacturers):

S.N.	PARAMETER	CRITERIA	Maximum Marks	Marks Awarded
1.	9.1 Growth of Net Worth over previous year (%) Average of three years to be worked out	More than 20 % : 5 10 – 20 % : 4 5 – 10 % : 3 > 0 & < 5 % : 2 0 or below : 0	5	
2.	9.3 DEBT EQUITY RATIO <u>Long term Debt (9.2)</u> Net worth (9.1)	1 : 1 : 5 1.1 upto 1.5 : 1 : 4 1.6 upto 2.0 : 1 : 3 2.0 & above : 1 : 2	5	
3.	9.5 QUICK RATIO <u>CA - INVENTORIES {9.5(1)-9.5(1)c}</u> Current liability {9.5 (2)}	1 : 1 : 5 1 : 1 upto 1.5 : 4 1 : 1.5 upto 1.75 : 3 1 : 1.75 upto 2.5 : 2 1 : > 2.5 : 0	5	
4.	9.6 Growth in Sales over previous year (%) Average of three years to be worked out	More than 35% : 5 20 -35 % : 4 10 – 20 % : 3 5 – 10 % : 2 > 0 & < 5 % : 1 0 or negative : 0	5	
5.	9.7 PROFIT BEFORE TAX  Growth over previous year (%)	More than 20 % : 5 10 – 20 % : 4 5 – 10 % : 3 > 0 & < 5 % : 2 0 or below : 0	5	
6.	9.8 Whether the supplier has been referred to BIFR / NCLT/ any other similar Govt agency	Yes: -5 No : 0	0	
7.	9.9 Whether the supplier is a potentially sick company	Yes: -3 No : 0	0	
<b>TOTAL</b>			<b>25</b>	

Note: If the supplier is new in business and does not have past data, then the evaluation will be done on the basis of information provided by him and will be decided by MISCC.

### 2. FINANCIAL INFORMATION (for Indian Stockist/ Trader/ Distributor/ Dealer/ Authorised Agent/ Channel partner/ Indian Sales office or Subsidiary of registered foreign principal):

S.N.	PARAMETER	CRITERIA	Maximum Marks	Marks Awarded
1.	9.6 Growth in Sales over previous year (%) Average of three years to be worked out	More than 35% : 5 20 -35 % : 4 5 - 20 % : 3 >0 - 5 % : 2 0 or negative : 0	5	
2.	9.7 PROFIT BEFORE TAX  Growth over previous year (%)	More than 20 % : 5 5 – 20 % : 4 >0 – 5 % : 3 0 or below : 0	5	

BHEL CERTIFIED ASSESSOR

# BHARAT HEAVY ELECTRICALS LIMITED SUPPLIER REGISTRATION FORM

FORM NO. SRF(I) 01 (INDIAN SUPPLIER)

ANNEXURE-II

Page 16 of 17

## Part D : SCORE SHEET

### 3. QUALITY SYSTEM :

S.N.	PARAMETER	CRITERIA	Maxm. Marks	Marks Awarded
1.	Incoming Material control System	System availability : Yes: 1 No : 0	1	
		Availability of Organisation chart Yes: 1 No : 0	1	
2.	Process control	Work instruction available: Yes: 1 No : 0	1	
		Record of process Control : Available : 2 Partial record : 1 Not available: 0	2	
3.	Manufacturing / Testing Procedure Qualification	Procedure Qualification Specification : Adequate : 3 In adequate: 1 Not available : 0	3	
4.	Personnel qualification	Record of PQR: Adequate : 3 In adequate: 1 Not available : 0	3	
5.	Calibration system	Adequate : 3 In adequate: 1 Not available : 0	3	
6.	System of Identification & Traceability of materials, tools, jigs, fixtures & processed components, etc.	Procedure available : Adequate : 2 In adequate: 1 Not available : 0	2	
7.	System of Storage/ preservation/ painting & packing	Procedure available : Adequate : 2 In adequate: 1 Not available : 0	2	
8.	System of NCR disposition & corrective preventive action	Two copies of NCR & CAPA Available :2 Not available : 0	2	
9.	Customer complaints handling system	System available : Yes: 1 No : 0	1	
		Complaints registered & resolved : 2 Complaints registered & partially resolved : 1 Complaints not registered or not resolved : 0	2	
10.	Safety measures	System available : Yes: 1 No : 0	1	
		Record available : Yes: 1 No : 0	1	
<b>TOTAL</b>			<b>25</b>	

BHEL CERTIFIED ASSESSOR

# BHARAT HEAVY ELECTRICALS LIMITED SUPPLIER REGISTRATION FORM

FORM NO. SRF(I) 01 (INDIAN SUPPLIER)

ANNEXURE-II  
Page 17 of 17 amdt.01

## **Part D : SCORE SHEET**

### **4. TECHNICAL COMPETENCE**

Column no. 1 to 4 to be filled by MISCC before sending to supplier. Column no. 5 to be filled by BHEL certified Assessor after evaluation of supplier response.

Sl. No (1)	Parameter (2)	Scoring criteria (3)	Maximum Marks (4)	Marks obtained (5)
	<b>TOTAL</b>		<b>25</b>	

#### **SUMMARY:**

Sl. No	Criteria	Maxm Marks	Qualifying marks *	Marks obtained	Recommendation for registration
1.	Organisational Soundness	50	30		<b>Recommended :</b>  Permanent code /Development code/ Trial code  <b>Not recommended</b>
	Financial Information				
2.	Quality System	25	15		
3.	Technical Competence	25	15		
	TOTAL	100	60		

**\*Minimum Qualifying Score in Each category shall be 60%.**

#### **REGISTRATION CRITERIA:**

Sl. No	Score	Recommendation
1.	More than 90	Supplier is to be registered and given Permanent code, Normally no visit is called for.
2.	>75 <=90	Supplier may be visited if recommended by MISCC or to be registered and given permanent code.
3.	>=60 <=75	Supplier may carry out suggested improvements if advised by MISCC Supplier's visit is mandatory. Trial/ Development code may be given.
4.	Less than 60	Not to be registered

Signatures: MISCC and Supplier Evaluation Team (in case of visit)

1)

2)

3)

4)

5)

6)

BHEL CERTIFIED ASSESSOR
-------------------------

	Annexure-III  <b>GUIDELINES TO FOREIGN SUPPLIERS FOR FILLING UP SUPPLIER REGISTRATION FORM</b>	Document No.	AA:MM:SR:01
		Revision No.	01
		Page No.	I of II

1. Prospective Suppliers may also visit our web site [www.bhel.com](http://www.bhel.com) (link Supplier Registration -> New Supplier Required) to know more about the requirement of new suppliers for various items in our units.
2. Registration Form no. SRF(F)01 may be obtained from BHEL website [www.bhel.com](http://www.bhel.com).
3. Application for registration, with a covering letter detailing where your products can find application (if possible) in BHEL unit(s), should be sent to:

Supplier Development Cell  
*Unit Name:*  
Bharat Heavy Electricals Ltd.  
*City:*  
India

4. In case registration is being sought in multiple units of BHEL, please send the separate application to each unit.
5. Any clarification with respect to procedure for registration may be obtained from the Supplier Development Cell of respective BHEL unit.
6. All columns are to be filled up properly in the space provided for. Wherever it is not applicable, mention it as "Not Applicable". The form is to be signed by the authorised signatory and submitted in original.
7. Please attach separate sheet if the space provided is insufficient. For any other information also, separate sheet may be attached.
8. Any information / clarification required by BHEL during processing of registration must be given expeditiously.
9. Please ensure that all required enclosures are attached with the filled up Supplier Registration Form and all enclosures are numbered & list of enclosures is given as required.
10. As multiple copies of the application forms are required for processing at our end, please do not spiral bound the application forms or its enclosures and instead send them in two hole clip flat file.
11. Please fill up the check- list given on next page and send along with the Supplier Registration Forms to BHEL.
12. Please note that if you are registered and participate in Tender process and qualify to get order from BHEL, your performance based on Quality of your product, delivery performance and service rendered will be evaluated inline with Chapter VI.
13. If you are attaching a document in a language other than English, a self attested English translated document may please be also attached.

	Annexure-III <b>CHECK-LIST FOR FOREIGN          SUPPLIERS REGISTRATION FORM</b>	Document No.	AA:MM:SR:01
		Revision No.	01
		Page No.	II of II

S.N.	Check-Point	Yes/No
1.0	Information against all points in the Supplier Registration Form has been given.	
2.0	Authorisation letter has been enclosed (in case of Indian representative)	
3.0	Banker's certificate has been enclosed	
4.0	Are you an ISO: 9001 accredited supplier?	
4.1	If yes, have you enclosed copy of ISO 9001 accreditation certificate & "Table of Contents" of your Quality Manual?	
4.2	If no, have you enclosed written down procedure / manual of Quality Management System?	
5.0	Have you enclosed experience list/ performance certificate ( as per sl. 3.0 of the form SRF(F) 01 )	
6.0	List of enclosures has been furnished ( as per Sl 5.0 of the form SRF(F) 01)	
7.0	All the parts of the form & enclosures have been signed by Authorised Signatory.	
8.0	D&B Report/ Creditreform report etc. has been attached.	

Signature & seal  
(Authorised Signatory)

Date :

Note : This check list is to be attached with the filled up Supplier Registration Form.

**BHARAT HEAVY ELECTRICALS LIMITED , INDIA**

ANNEXURE- III

**FORM NO. SRF(F)01 : (FOREIGN SUPPLIER)**

Page 1 of 2

**ALL THE PAGES OF THE FORM ARE TO BE SIGNED ALONGWITH SEAL BY THE AUTHORISED SIGNATORY**

SUPPLIER REGISTRATION FORM	
<b>1.0 GENERAL INFORMATION :</b>	
1.1 NAME OF SUPPLIER : (TO BE REGISTERED)	
1.2 SUPPLIER ADDRESS : (TO BE REGISTERED)	
E - Mail :	
TELEPHONE : (Landline)-	Mobile
WEB SITE :	
<b>1.3 DETAILS OF FACTORY / WORKS :</b>	
ADDRESS :	
E - Mail :	
TELEPHONE : (Landline)-	Mobile
<b>1.4 DETAILS OF MARKETING REPRESENTATIVE (OUTSIDE INDIA , IF ANY)</b>	
ADDRESS :	
E - Mail :	
TELEPHONE : (Landline)-	Mobile
<b>1.5 DETAILS OF INDIAN REPRESENTATIVE, IF ANY : ( Attach authorisation letter )</b>	
NAME :	
ADDRESS :	
E - Mail :	
TELEPHONE : (Landline)-	Mobile
<b>1.6 CHIEF EXECUTIVE :</b>	
<b>1.7 YEAR OF ESTABLISHMENT :</b>	
<b>SUPPLIER'S AUTHORIZED SIGNATORY</b>	
<b>BHEL CERTIFIED ASSESSOR</b>	

# **BHARAT HEAVY ELECTRICALS LIMITED , INDIA**

ANNEXURE-III

## **FORM NO. SRF(F)01 : (FOREIGN SUPPLIER)**

Page 2 of 2 amdt.-04

- 1.8 YEAR OF COMMENCEMENT OF BUSINESS :
- 1.9 PRODUCTION CAPACITY PER ANNUM (details of major manufacturing/ testing facilities to be given) :
- 1.10 PARTICULARS OF PRODUCTS INCLUDING SPECIFICATION AND RANGE OFFERED FOR REGISTRATION : ( ATTACH BROCHURES AND CATALOGUES )
- 1.11 NAME (S) OF BANKERS :
- 1.12 BANKER'S CERTIFICATE AS TO CREDITWORTHINESS OF THE CLIENT  
(Enclose Certificate) :
- 1.13 PORT OF LOADING :
- 1.14 NEAREST AIRPORT :
- 1.15 Report from D&B/ Creditreform etc. (As per Cl. 7.1 of Chapter V) (**MANDATORY**):

### **2.0 FINANCIAL INFORMATION : (FOR LAST 3 YEARS)**

PARAMETER	YEAR -1	YEAR -2	YEAR -3
ANNUAL TURN OVER			
PROFIT AFTER TAX			

( COPY OF AUDITED ANNUAL ACCOUNTS FOR LAST 3 YEARS TO BE ENCLOSED)

### **3.0 QUALITY MANAGEMENT SYSTEM :**

- 3.1 IS THE COMPANY ISO:9001 CERTIFIED : YES / NO
- 3.1.1 IF YES, ENCLOSE COPY OF CERTIFICATE & TABLE OF CONTENTS OF QUALITY MANUAL.
- 3.1.2 IF NO, ENCLOSE QUALITY MANAGEMENT SYSTEM OR WRITTEN DOWN PROCEDURE

- 4.0 EXPERIENCE LIST/ PERFORMANCE CERTIFICATE FOR OFFERED / SIMILAR ITEMS :**  
(ATTACH LIST OF PRESENT CUSTOMERS WITH NAME & ADDRESS FOR OFFERED / SIMILAR TYPE & SIZE OF ITEM / EQUIPMENT FOR WHICH REGISTRATION HAS BEEN SOUGHT AND WITH WHOM YOU HAVE CONTINUOUS BUSINESS SINCE LAST THREE YEARS )

### **5.0 IF REGISTERED IN ANY OTHER UNIT OF BHEL, PLEASE PROVIDE DETAILS:**

### **6.0 ANY OTHER INFORMATION:**

### **7.0 LIST OF ENCLOSURES :**

(BROCHURES, CATALOGUES, TECHNICAL LITERATURE ETC.)

Signature & Seal

AUTHORISED SIGNATORY

E – Mail

NAME :

TELEPHONE : (Landline):

DESIGNATION :

Mobile :

**DATE :**

**BHEL CERTIFIED ASSESSOR**