	<b>SPECIFICATION FOR CHLORINE-DI-OXIDE (ClO<sub>2</sub>) GENERATOR</b>	<b>SPEC.NO.ROS: 6112</b>
		<b>REV.: 00</b>

**BHARAT HEAVY ELECTRICALS LIMITED,  
RANIPET- 632 406.**

**TECHNICAL SPECIFICATION  
FOR  
CHLORINE-DI-OXIDE (ClO<sub>2</sub>) GENERATOR SYSTEM**

00	08.01.14	SS	MSM/MN	SK	Fresh issue
Rev.No	Date	Prepared	Checked	Approved	Remarks

	<b>SPECIFICATION FOR CHLORINE-DI-OXIDE (ClO<sub>2</sub>) GENERATOR</b>	SPEC.NO.ROS: 6112
		REV.: 00

## INDEX

SECTION	DESCRIPTION	PAGE NO
SECTION - 1	SCOPE OF SUPPLY	3
SECTION - 2	PROJECT INFORMATION	4
SECTION - 3	TECHNICAL REQUIREMENT	4
	<ul style="list-style-type: none"> <li>- SYSTEM CAPACITY</li> <li>- INLET WATER QUALITY FOR DESIGN</li> <li>- PERFORMANCE &amp; GUARANTEE REQUIREMENT</li> </ul>	
SECTION - 4	TECHNICAL SPECIFICATION - MECHANICAL	5
	<ul style="list-style-type: none"> <li>- DESIGN CRITERIA</li> <li>- TERMINAL POINTS</li> <li>- EQUIPMENT SPECIFICATION</li> <li>- GENERAL DESIGN REQUIREMENTS</li> <li>- PIPING</li> <li>- VALVES</li> <li>- PAINTING</li> <li>- VENDOR LIST</li> </ul>	
SECTION - 5	TECHNICAL SPECIFICATION FOR ELECTRICAL, CONTROLS & INSTRUMENTATION (ROS 4079 & 4080)	19
SECTION - 6	TECHNICAL DETAILS FOR CIVIL WORKS	19
SECTION - 7	PERFORMANCE GUARANTEE	20
	- PERFORMANCE GUARANTEE	
SECTION - 8	SPARES	20
	<ul style="list-style-type: none"> <li>- COMMISSIONING SPARES</li> <li>- MANDATORY SPARES</li> <li>- RECOMMENDED SPARES FOR 2 YRS O&amp;M</li> </ul>	
SECTION - 9	ERECTION, COMMISSIONING, TRIAL OPERATION, PG TEST AND HANDING OVER	22
SECTION - 10	DOCUMENTATION	22
SECTION - 11	ATTACHMENTS	25
SECTION - 12	IMPORTANT POINTS TO BIDDERS	25

	<p style="text-align: center;">SPECIFICATION FOR CHLORINE-DI-OXIDE (ClO<sub>2</sub>) GENERATOR</p>	<p>SPEC.NO.ROS: 6112</p>
		<p>REV.: 00</p>

## 1.0 SCOPE OF SUPPLY

The intent of this specification is to cover Design, Engineering, Manufacturing, shop testing, supply, Erection & Commissioning, Performance guarantee test and handing over of **Chlorine-Di-oxide generator system** mentioned below.

The scope shall fully cover the requirement of the Design Criteria and Technical requirement of this specification for treating the raw water to meet the filtered water requirement of Plant. The scope of supply & services shall include but not limited to the following

- a. 2x100% Dilution water transfer pumps with motors & acc.
- b. 1x100% Sodium Chlorite unloading pump (NaClO<sub>2</sub>) with motor & acc.
- c. 1x100% Sodium Chlorite bulk storage tank
- d. 1x100% Sodium Chlorite dosing system consisting of 2x100% dosing pumps & accessories.
- e. 1x100% Hydrochloric acid unloading pump (HCl) with motor & acc.
- f. 1x100% Hydrochloric acid bulk storage tank
- g. 1x100% Hydrochloric acid dosing system consisting of 2x100% dosing pumps & accessories.
- h. 2x100% Chlorine-di-oxide (ClO<sub>2</sub>) generator system
- i. 3 sets of Safety showers, eye wash & accessories
- j. 1 set of interconnecting piping & valves between the systems
- k. 1 set of ClO<sub>2</sub> solution piping, fittings, valves etc. from generator to dosing point (~400m) [supply only, Erection by Customer]
- l. 1 set of ClO<sub>2</sub> injection nozzle at dosing point
- m. Electricals, controls & instrumentation required within the system
- n. Erection & Commissioning, PG test & handing over
- o. 1 set of mandatory spares
- p. Operation chemicals (HCl-40MT & NaClO<sub>2</sub>-40MT)

On site chlorine dioxide generation and dosing system is envisaged for iron removal / oxidation. The chlorine dioxide shall be generated on site and dosed in the incoming raw water pressure line upstream of the fire water branch-off for iron removal / oxidation.

**Items though not mentioned but needed to make the system complete as stipulated under these specifications are also to be furnished unless otherwise specifically excluded.**

- 1.1 It is not the intent to specify all the details of the design & manufacture. However, the equipment shall conform in all respects to high standard of design, engineering and workmanship and shall be capable of performing the required duties in a manner acceptable to Engineer / Customer, who will interpret the meaning of drawing & the specification and shall be entitled to reject any work or material, which is not in full accordance herewith.

	<b>SPECIFICATION FOR CHLORINE-DI-OXIDE (ClO<sub>2</sub>) GENERATOR</b>	<b>SPEC.NO.ROS: 6112</b>
		<b>REV.: 00</b>

- 1.2 In case of any deviation, the Bidder shall indicate the same, clause by clause in the deviation schedule. In the absence of the same it will be construed that the bid confirms strictly to the specification.
- 1.3 General terms & conditions, instructions to the bidder & other attachments referred to elsewhere are part of this specification.
- 1.4 The order of priority of this specification is as follows:
- a. Technical requirement/Equipment Specification,
  - b. Drawings
  - c. General design requirements
- Any contradiction either between various parts or contents of the specification shall be a matter for clarification to be obtained by the bidder. The Customer's decision shall be final. However, as a general guideline the details furnished in the Equipment specification shall prevail.
- 1.5 The material shall be dispatched to site as per the bidder's shipping list approved by customer. The format for the shipping list & quality plan will be given by customer after order for the successful bidder.

## 2.0 PROJECT INFORMATION

- 2.1 Owner : ONGC Petro Additions Ltd.
- 2.2 Project Title : OPaL Raw water treatment plant  
(Membrane filtration based)
- 2.3 Location : Dahej, Gujarat
- 2.4 Nearest Railway Station / Access : Dahej / Bharuch  
Road

## 3.0 TECHNICAL REQUIREMENT

### 3.1 CHLORINE-DI-OXIDE (ClO<sub>2</sub>) SYSTEM CAPACITY

- No. of streams : 2 (1W+1S)
- Capacity of each generator : 10 kg/hr
- Type : **Submerged/ encapsulated**

The ClO<sub>2</sub> generator unit shall be a skid mounted unit and can be

- a. ClO<sub>2</sub> Generator unit mounted on an enclosed Skid in an enclosure
- b. In-line Type ClO<sub>2</sub> Generator unit.

	<b>SPECIFICATION FOR CHLORINE-DI-OXIDE (ClO<sub>2</sub>) GENERATOR</b>	<b>SPEC.NO.ROS: 6112</b>
		<b>REV.: 00</b>

### 3.2 DILUTION WATER QUALITY

- a) TDS : ~500 ppm
- b) TSS : 10 - 50 ppm

### 3.3 PERFORMANCE & GUARANTEE REQUIREMENT OF ClO<sub>2</sub> GENERATOR

The plant design should meet the requirement as indicated below:

S.No	Description	Quantity
01	Dosage requirement	2 mg/ l, to maintain free residual chlorine dioxide of 0.2 – 0.4ppm in raw water for a flow of 4500cu.m/hr
02	Capacity (each generator)	10 kg/ hr of ClO <sub>2</sub>

### 4.0 TECHNICAL SPECIFICATION - MECHANICAL

#### 4.1 DESIGN CRITERIA

Operation of Chlorine Dioxide generator shall be completely automatic through PLC system. PLC system (excluded from bidder's scope) will be provided by Customer. Bidder shall render all technical assistance in implementing the sequential operation of their system with the PLC system.

Bidder to draw Dilution water from Clarified water tank. Clarified water will be made available at Clarified water tank outlet nozzle. Bidder to pump dilution water from Clarified water tank nozzle to Chlorine dioxide generator using Dilution water transfer pumps.

HCl (30%) and NaClO<sub>2</sub> (25%) from tankers shall be unloaded to respective Bulk storage tanks (bulk storage tanks by Bidder) using unloading pumps (Bidder's scope).

Required quantity of HCl and NaClO<sub>2</sub> shall be dosed for usage in chlorine dioxide generator using respective dosing systems.

Chlorine dioxide dosing shall be done as shock/ continuous @ 2ppm to maintain free residual chlorine dioxide of 0.2 – 0.4ppm in raw water & drinking water.

	<p style="text-align: center;">SPECIFICATION FOR CHLORINE-DI-OXIDE (ClO<sub>2</sub>) GENERATOR</p>	<p>SPEC.NO.ROS: 6112</p>
		<p>REV.: 00</p>

Necessary piping, pneumatic and manual operated valves, instruments, controls & interlocks shall be provided in the system for auto operation and also as per the P & ID (Process & Instrumentation Diagram) drawing enclosed with this specification. Instrumentation shown in the P&ID is minimum requirement. List of minimum instrumentation required are specified in a separate clause in this specification. Any additional instrumentation if any shall be included by the bidder in their scope and the same shall be clearly included in bidder's scope and indicated in the offer clearly.

The details of the equipment / system are elaborated in respective section of this specification.

#### 4.2 TERMINAL POINTS:

- a. Dilution water will be made available at Clarified water tank outlet nozzle (DN80/ 3") with flange having drilling standard ANSI B16.5 150lbs by BHEL. Bidder's scope starts from mating flange, suction piping, dilution water transfer pumps, etc.
- b. Acid (30% HCl) required for Chlorine dioxide generator shall be made available in HCl tankers once in 15 days by Customer. Bidder to provide unloading pumps along with suction piping for drawing HCl from Tanker and storing in Bulk HCl storage tank and further use.
- c. Sodium Chlorite (25% NaClO<sub>2</sub>) required for Chlorine dioxide generator shall be made available in NaClO<sub>2</sub> tankers once in 15 days by Customer. Bidder to provide unloading pumps along with suction piping for drawing NaClO<sub>2</sub> from Tanker and storing in Bulk NaClO<sub>2</sub> storage tank and further use.
- d. The entire scope of Chlorine dioxide generator shall be under Bidder's scope up to dosing of ClO<sub>2</sub> in raw water piping near raw water reservoir. Refer attached plant layout for pipe routing considerations. (~400m).
- e. Required instrument air for pneumatic valve operation shall be tapped off from the air line running nearby the plant boundary. Bidder shall provide the instrument air requirement in their offer.
- f. Power cables for all the drives will be provided by customer at the terminal box of respective motors supplied by the bidder. Bidder shall provide the drives list in their offer. Power supply shall be 415 V, 3 phase supply.
- g. Control cables, Instrument cables shall be provided by the bidder up to the junction box (by bidder) of individual skid / system. Customer will provide the cables from these local junction box up to PLC/LTMCC panel. PLC & MCC are in customer scope.

	<b>SPECIFICATION FOR CHLORINE-DI-OXIDE (ClO<sub>2</sub>) GENERATOR</b>	SPEC.NO.ROS: 6112
		REV.: 00

- h. Necessary civil works like equipment foundation with pockets, trenches, dyke walls, kerb wall are excluded from bidder's scope. Bidder shall provide these details in their offer. However the foundation materials like grouting mix, foundation bolts & packing shims etc, are in bidder's scope.
- i. Chlorine dioxide system (Chlorine dioxide generator with valves, piping & headers, pumps and rest of the equipment) equipment should be accommodated by the bidder within the given space / building. No additional space will be provided. Bidder should provide the detailed arrangement layout drawings along with the bid. The pipe and header routings shall be considered above ground only. Necessary supports for ClO<sub>2</sub> dosing line will be provided by the customer as per bidder's requirement. For that, bidder to provide the detailed support arrangement & fabrication drawing. Necessary clamping arrangements shall be in bidder's scope. The supports for the rest of the piping, headers & valves for individual skids are in bidder's scope.

#### 4.3 EQUIPMENT SPECIFICATION:

The technical requirement of the equipment is indicated below. In addition, the applicable P & ID and Layout enclosed with this specification shall be referred.

##### 4.3.1 ClO<sub>2</sub> DILUTION PUMPS WITH MOTOR & ACCESSORIES:

- |                                  |  |
|----------------------------------|--|
| 1) No. of Pumps                  | : 2 x 100%   |
| 2) Location                      | : Outdoor  |
| 3) Operation                     | : Continuous   |
| 4) Type                          | : Horizontal centrifugal ( Non-API)  |
| 5) MOC                           |  |
| - Casing, Impeller& Stuffing Box | : Carbon Steel   |
| - Shaft                          | : SS 410   |
| 6) Make                          | : As per Mech.Vendor list in Annexure-A  |
| 7) Location                      | : Indoor   |
| 8) Speed of the pump             | : 1500 rpm   |
| 9) Design Flow /pump             | : 10 m <sup>3</sup> /hr (min.) bidder to decide  |
| 10)Design Head of pumps          | : As per system requirement + friction head for design flow of the pump. The system requirement is min. 2.5 bar at dosing point. |
| 11)Bearing                       | : Anti-friction  |
| 12)Seal                          | : Gland packing  |
| 13)Lubrication                   | : bidder to specify  |
| 14)Coupling                      | : Flexible & spacer type   |
| 15)Operating range               | : 30 – 120% of rated flow  |
| 16) Pump characteristic          | : Non-overloading type & stable  |

	<b>SPECIFICATION FOR CHLORINE-DI-OXIDE (ClO<sub>2</sub>) GENERATOR</b>	<b>SPEC.NO.ROS: 6112</b>
		<b>REV.: 00</b>

- |                          |  |
|--------------------------|--|
| 17) Shut-off head        | : About 15 % more than the rated head  |
| 18) MOC of All fasteners | : GI   |
| 19) Accessories          | : a) Anchor bolts, nuts sleeves & Inserts to be embedded to concrete.<br>b) Drain plug, vent, coupling guard lifting lugs etc. |
| 20) Motor                | : As per ROS-4079 enclosed.  |
| 21) Motor rating (Max.)  | : 2.2 KW   |

#### **4.3.2 HCL UNLOADING PUMPS WITH MOTOR & ACCESSORIES:**

- |  |  |
|--|--|
| 1) No. of Pumps                          | : 1 x 100%   |
| 2) Application                           | : To unload liquid HCl of 30 to 33% Conc. solution from tanker lorry at road   |
| 3) Location                              | : outdoor  |
| 4) Discharge flow                        | : 15m <sup>3</sup> /hr   |
| 5) Discharge head                        | : 15 mwc   |
| 6) Suction                               | : From Tanker lorry  |
| 7) Operation                             | : Intermittent   |
| 8) Type                                  | : Horizontal centrifugal (Non-API)   |
| 9) MOC                                   |  |
| i. Casing                                | : PP/ PVDF   |
| ii. Impeller                             | : Teflon   |
| iii. Seal/ packing                       | : Single mechanical seal – API plan-11   |
| iv. Shaft                                | : EN 8   |
| v. Shaft sleeve                          | : Ceramic  |
| 10) Speed of the pump                    | : 1500 rpm   |
| 11) Bearing                              | : Anti-friction  |
| 12) Coupling                             | : Flexible (spacer type) with guard  |
| 13) MOC of All fasteners                 | : SS316/ better; to suit the environment   |
| 14) Base frame for Pump & Motor mounting | : Carbon steel with epoxy coated.  |
| 15) Accessories                          | : Suction pipe/ rigid hose 20m minimum, Suction strainer (Y-type), drain & vent valves, delivery piping to storage tank and flushing arrangement piping for the flushing of the pump after unloading the chemical etc. The operation of the pump shall be controlled by the level switch in the tank (pump shall be stopped before the tank overflows) |
| 16) Valves & strainers                   | : CPVC, PN16   |

	<b>SPECIFICATION FOR CHLORINE-DI-OXIDE (ClO<sub>2</sub>) GENERATOR</b>	<b>SPEC.NO.ROS: 6112</b>
		<b>REV.: 00</b>

17) Motor : As per specification ROS:4079

#### 4.3.3 BULK ACID (HCL) STORAGE SYSTEM:

- 1) Tank : Bulk Acid storage
- 2) Medium used : 30 to 33% Hydrochloric Acid
- 3) Location : Outdoor
- 4) Quantity : 1 no.
- 5) Capacity (usable volume) : 15 days requirement or 15 m<sup>3</sup> whichever is higher + 1m<sup>3</sup> for other use.
- 6) MOC : FRP (Vinyl ester resin) with UV protection
- 7) Type : Horizontal, cylindrical with dished ends
- 8) Pressure : Atmospheric
- 9) Tank dia. : 2.5 m (min.) (inside)
- 10) Tank thickness : 10 mm (min.) The glass content of inner layer shall be 25 to 30 % by weight. The glass content of filament wound structural layer shall be 55 to 70 % by weight.
- 11) Piping, valves & fittings : CPVC, PN16
- 12) Tank nozzle flange thickness : 15 mm (min.)
- 13) Accessories : Each tank consists of necessary manholes, inlet/ outlet/ drain & vent nozzles, piping, valves, access ladder with safety cage, top platform, hand rails for manhole access, safety showers, eyewash etc. Suitable handling arrangement/ lifting lugs are to be provided in the tank for easy movement.
- 14) Instruments : Level transmitters (Radar type),  
Level indicators, density indicator
- 15) The tank should be supplied along with support saddle with flat bottom so that it can be mounted on Concrete pedestal.
- 16) Design code : BS 4994 or equivalent
- 17) Additional nozzle with valves (2nos.) of DN50

Note: Height of the pedestals shall be 1.0m from FGL

	<b>SPECIFICATION FOR CHLORINE-DI-OXIDE (ClO<sub>2</sub>) GENERATOR</b>	<b>SPEC.NO.ROS: 6112</b>
		<b>REV.: 00</b>

#### 4.3.4. HCl DOSING SYSTEM

##### 4.3.4.1 HCl DOSING PUMPS:

- 1) No. of pumps : 2 x 100%
- 2) Application : Acid (HCl (33%)) dosing
- 3) Location : outdoor
- 4) Stroke adjustment : manual
- 5) Dosing concentration & specific gravity : 30% (As required) & 1.15
- 6) Design pressure : 10 kg/cm<sup>2</sup>
- 7) Pump design flow rate : As per requirement
- 8) Pump suction type : Flooded
- 9) Pump head MOC
  - Wetted parts : PP
- 10) MOC of balls : Ceramic

**Note: Pump with motor assembly shall be designed to suit 4-20mA signal with stepper motor to accommodate turn down ration of approximately 1:750.**

##### 4.3.4.2 DOSING SKID:

- 1) Skid frame : 1 no.
- 2) Interconnecting piping & valves : 1 set
- 3) Pressure gauge & pressure relief valve : 1 set
- 4) Fume absorber : 1 no.
- 5) Junction box with terminal box for pump : 1 no. for each pump
- 6) Piping system MOC & size : CPVC industrial grade, PN16 rating, DIN standard or Sch.80 class. All ball valves shall be of union type only.

##### 4.3.5 SODIUM CHLORITE UNLOADING PUMPS WITH MOTOR & ACCESSORIES:

- 1) No. of Pumps : 1 x 100%
- 2) Application : To unload liquid NaClO<sub>2</sub> of 25% Conc. solution from tanker lorry at road
- 3) Location : outdoor
- 4) Discharge flow : 15m<sup>3</sup>/hr
- 5) Discharge head : 15 mwc
- 6) Suction : From Tanker lorry
- 7) Operation : Intermittent
- 8) Type : Horizontal centrifugal (Non-API)
- 9) MOC

	<b>SPECIFICATION FOR CHLORINE-DI-OXIDE (ClO<sub>2</sub>) GENERATOR</b>	SPEC.NO.ROS: 6112
		REV.: 00

i. Casing	: PP/ PVDF
ii. Impeller	: Teflon
iii. Seal/ packing	: Single mechanical seal – API plan-11
iv. Shaft	: EN 8
v. Shaft sleeve	: Ceramic
10) Speed of the pump	: 1500 rpm
11) Bearing	: Anti-friction
12) Coupling	: Flexible (spacer type) with guard
13) MOC of All fasteners	: SS316/ better; to suit the environment
14) Base frame for Pump & Motor mounting	: Carbon steel with epoxy coated.
15) Accessories	: Suction pipe/ rigid hose 10m minimum, Suction strainer (Y-type), drain & vent valves, delivery piping to storage tank and flushing arrangement piping for the flushing of the pump after unloading the chemical etc. The operation of the pump shall be controlled by the level switch in the tank (pump shall be stopped before the tank overflows)
16) Valves & strainers	: CPVC, PN16
17) Motor	: As per specification ROS:4079

#### **4.3.6 BULK SODIUM CHLORITE (NaClO<sub>2</sub>) STORAGE SYSTEM:**

1) Tank	: Bulk NaClO <sub>2</sub> storage
2) Medium used	: 25% NaClO <sub>2</sub>
3) Location	: Outdoor
4) Quantity	: 1 no.
5) Capacity (usable volume)	: 15 days requirement or 15 m <sup>3</sup> whichever is Higher
6) MOC	: FRP (Vinyl ester resin) with UV protection
7) Type	: Horizontal, cylindrical with dished ends
8) Pressure	: Atmospheric
9) Tank dia.	: 2.5 m (min.) (inside)
10) Tank thickness	: 10 mm (min.) The glass content of inner layer shall be 25 to 30 % by weight. The glass content of filament wound structural layer shall be 55 to 70 % by weight.
11) Piping, valves & fittings	: cPVC, PN16
12) Tank nozzle flange thickness	: 15 mm (min.)
13) Accessories	: Each tank consists of necessary manholes,

	<p style="text-align: center;">SPECIFICATION FOR CHLORINE-DI-OXIDE (ClO<sub>2</sub>) GENERATOR</p>	<p>SPEC.NO.ROS: 6112</p>
		<p>REV.: 00</p>

inlet/ outlet/ drain & vent nozzles, piping, valves, access ladder with safety cage, top platform, hand rails for manhole access, safety showers, eyewash etc. Suitable handling arrangement/ lifting lugs are to be provided in the tank for easy movement.

14) Instruments : Level transmitters (Radar type),  
Level indicators, density indicator

15) The tank should be supplied along with support saddle with flat bottom so that it can be mounted on Concrete pedestal.

16) Design code : BS 4994 or equivalent

Note: Height of the pedestals shall be 1.0m from FGL

#### 4.3.7 NaClO<sub>2</sub> DOSING SYSTEM

##### 4.3.7.1 NaClO<sub>2</sub> DOSING PUMPS:

- 1) No. of pumps : 2 x 100%
- 2) Application : Sodium Chlorite (NaClO<sub>2</sub> (25%)) dosing
- 3) Location : outdoor
- 4) Stroke adjustment : manual
- 5) Dosing concentration & specific gravity : 25% (As required) & 1.27
- 6) Design pressure : 10 kg/cm<sup>2</sup>
- 7) Pump design flow rate : As per requirement
- 8) Pump suction type : Flooded
- 9) Pump head MOC
  - Wetted parts : PP
- 10) MOC of balls : Ceramic

**Note: Pump with motor assembly shall be designed to suit 4-20mA signal with stepper motor to accommodate turn down ration of approximately 1:750.**

##### 4.3.7.2 DOSING SKID:

- 1) Skid frame : 1 no.
- 2) Interconnecting piping & valves : 1 set
- 3) Pressure gauge & pressure relief valve : 1 set
- 4) Junction box with terminal box for pump : 1 no. for each pump

	<b>SPECIFICATION FOR CHLORINE-DI-OXIDE (ClO<sub>2</sub>) GENERATOR</b>	<b>SPEC.NO.ROS: 6112</b>
		<b>REV.: 00</b>

- 5) Piping system MOC & size : cPVC industrial grade, PN16 rating, DIN standard or Sch.80 class. All ball valves shall be of union type only.

#### 4.3.8 CHLORINE DIOXIDE GENERATOR SKIDS:

- 1) No. of Skids : 2 x 100%
- 2) Location : Under shade
- 3) Type : ClO<sub>2</sub> generator unit mounted on an enclosed Skid, Submerged/ underwater encapsulated
- 4) Net output capacity / skid : 10 kg / hr
- 5) Minimum conversion efficiency : >90 % with respect to ClO<sub>2</sub> yield
- 6) MOC of ClO<sub>2</sub> reactor : fiberglass
- 7) MOC of ClO<sub>2</sub> solution line : HDPE/ uPVC
- 8) General
  - a. Feed reagent filters shall be provided on the inlet lines to the chlorine dioxide generator unit.
  - b. Air contact with chlorine dioxide solution should be controlled to limit the potential for explosive concentrations possibly building up within the reactor.
  - c. Necessary supports for the piping shall be provided by the bidder.
  - d. The skid MOC shall be of carbon steel with painting having sufficient strength and rigidity to support the equipment contained in the skid.
- 9) Following controls shall be provided with the following instruments & controls as a minimum.
  - i. pH in Chlorine dioxide solution dosing line
  - ii. Residual chlorine dioxide (ClO<sub>2</sub>) analyzer
  - iii. Flow meters on all chemical feed lines, dilution water lines, and chlorine dioxide solution lines.
  - iv. Pressure indicator & controller on the water inlet line to ClO<sub>2</sub> generators, chlorine dioxide dosing controller, low vacuum switch, solenoid valves, etc., all complete and as required shall be provided.
  - v. The dosing in inlet shall be automatically controlled based on the signal received from residual chlorine dioxide analyzer in the header
  - vi. All chemical storage tanks shall have automatic high and low level cut off.
  - vii. Chlorine dioxide leak detection system.
  - viii. In case of water supply to the generator stops, the chemical dosing pumps shall also stop automatically.
  - ix. Generator must be equipped with systems of dosing and/ or measurement for reagents and diluting water. These systems must be able to shut down the operation of the generator in case any of the supplies is cut off.

#### 4.4 GENERAL DESIGN REQUIREMENTS

The common requirements for the system are stated in the general design requirements. However the requirements indicated in the technical specification for mechanical equipment section 4.3 shall be strictly complied with.

	<p style="text-align: center;">SPECIFICATION FOR CHLORINE-DI-OXIDE (ClO<sub>2</sub>) GENERATOR</p>	<p>SPEC.NO.ROS: 6112</p>
		<p>REV.: 00</p>

#### 4.4.1 COMMON REQUIREMENTS:

1. Only latest revision of standards shall be used.
2. The tanks coming in contact with corrosive fluids should be compatible for the chemicals.
3. All the rotating equipment noise level shall be < 85dBA measured at 1 m distance from the equipment.
4. Sampling connections and air vent at the top most point of piping and vessels shall be provided at all stages of the Unit.
5. The size of the overflow pipes of all storage tanks shall be one size higher than inlet pipe sizes of these tanks.
6. All the piping & valves are to be located to facilitate easy accessibility and operation from the ground level.
7. All flange fasteners shall be GI MOC.
8. The fasteners shall be of stud type with spring washers & nuts.
9. The direction of Flow shall be indicated by an arrow at regular intervals on all pipelines.

#### 4.4.2 CENTRIFUGAL PUMPS:

1. The critical speed of the pumps shall be well away from the operating speed and in no case less than 130% of the rated capacity.
2. The pumps shall have stable head Vs capacity characteristic continuous rising towards shut-off with an approximate shut-off head of 15% more than the design head for radial flow type pumps.
3. Pumps shall be provided with non-return valve & shut off valve on discharge side and shut-off valve on suction side.
4. Unfiltered vibration velocity for horizontal pumps upto 3000 rpm with antifriction bearing or sleeve bearings when measured at the bearing housing in horizontal or vertical direction shall not exceed 4 mm/sec RMS.
5. Maximum BkW including the tolerances shall be indicated for guarantee purpose.
6. Pressure gauges shall be provided on discharge side of all pumps.
7. Each pump suction and discharge shall be installed with an expansion bellow.

	<b>SPECIFICATION FOR CHLORINE-DI-OXIDE (ClO<sub>2</sub>) GENERATOR</b>	SPEC.NO.ROS: 6112
		REV.: 00

8. The pumps shall be designed for continuous operation at its best efficiency to satisfy the performance requirements.
9. The pumps shall be controlled from remote panel and locally.

## 4.5 PIPING

### 4.5.1 LINE SIZING

1. Sizes of pipelines shall be selected such that the velocity of fluid in pipes does not exceed the following limits under conditions of maximum possible volumetric flow:
  - Pump Suction : <1.2 m/sec
  - Pump Delivery & header : ≤ 2 m/sec
  - Service water / Potable water : ≤ 2 m/sec
  - Compressed air : 15 m/s
2. All high points in piping system segments shall be provided with air vents along with valves. All low points in piping segments shall be provided with drains along with valves.
3. Compressed air pipe work shall be adequately drained to prevent internal moisture accumulation and moisture traps shall be provided at strategic location in piping system.
4. Necessary thrust blocks shall be provided to minimize water hammer & vibration in piping & headers.
5. Supporting arrangement of piping system shall be rigid and properly designed for systems where hydraulic shocks and pressure surges may arise in the system during operation.
6. Sufficient up stream and down stream lengths shall be provided for flow measuring device, control valves and other specialties.
7. Test certificate / compliance certificate to be furnished by the bidder for all the components instruments & piping etc.

### 4.5.2 MATERIALS OF CONSTRUCTION:

SL. NO.	SERVICE	SIZE	PIPES	FITTINGS	FLANGES	GASKETS	LINE JOINT
1.0	Low Pressure Application						

	<b>SPECIFICATION FOR CHLORINE-DI-OXIDE (ClO<sub>2</sub>) GENERATOR</b>	<b>SPEC.NO.ROS: 6112</b>
		<b>REV.: 00</b>

SL. NO.	SERVICE	SIZE	PIPES	FITTINGS	FLANGES	GASKETS	LINE JOINT
1.1	Dilution water pump suction & Discharge	Upto DN 100	UPVC , PN16 as per latest DIN standard	UPVC , PN16 as per latest DIN standard	UPGF / PP Flange drilling should be ANSI B16.5, 150 Class	Neoprene rubber gasket	Solvent cemented / flanged
1.2	Instrument Air & Plant Air line	All sizes	Galvanized as per IS 1239 , Heavy grade	Screwed fittings of Galvanized as per IS 1239 , Heavy grade	Not applicable. Screwed fitting shall be considered	Not applicable	Screwed connections
1.3	Chemical dosing lines (HCl & NaClO <sub>2</sub> )	All sizes	CPVC, Sch.80 of ASTM	CPVC, Sch.80 of ASTM	UPGF / PP Flange drilling should be ANSI B16.5, 150 Class	Viton rubber gasket	Solvent cemented / flanged
1.4	ClO <sub>2</sub> solution dosing line	All sizes	HDPE/ uPVC, PN16	HDPE/ uPVC, PN16	HDPE/ PP-GF	Viton rubber gasket	Solvent cemented / flanged

**Notes:**

1. All piping & valves supports shall be of dismantling type for easy maintenance using suitable bolted connections.
2. ClO<sub>2</sub> solution dosing line piping approx. 400m
3. ClO<sub>2</sub> solution line Elbows - 20 nos.
4. ClO<sub>2</sub> solution line Coupling arrangement
5. ClO<sub>2</sub> solution line Flanges - 5 sets
6. Solvent solution - as required.

## 4.6 VALVES

### 4.6.1 DESIGN AND CONSTRUCTION FEATURES

The following consideration shall be made during the design / selection of valves for the ClO<sub>2</sub> System.

1. Butterfly valves shall be used for isolation / regulation purpose.
2. The material of construction for the valves shall be as per the table no 4.6.2 given below.
3. The end connection for the diaphragm valves shall be of flanged type as per **ANSI B16.5, #150**.
4. Pressure rating of valves shall be of minimum PN16
5. Necessary pneumatic actuated valves shall be provided for auto operation of the plant as per the P & I diagram.
6. The painting shall be as per the requirements indicated in the painting specification.
7. Bidder shall furnish the valves schedule in the attached format. (Annexure-4)
8. Cast steel valves shall be provided for compressed air system.



SPECIFICATION FOR  
CHLORINE-DI-OXIDE (ClO<sub>2</sub>) GENERATOR

SPEC.NO.ROS: 6112

REV.: 00

#### 4.6.2 VALVE – MATERIALS

Sl. No.	Service	Valve Type	Size	BODY	Disc / Ball / Diaphragm	Stem / Shaft	Valve seat / Seat ring	Pressure rating	Valve Ends
1	Dilution water line	Butterfly Valve	≥65NB	ASTM A 216 GR.WCB	SS316	SS410	EPDM	#150	Wafer type
		Check Valve	≥65NB	ASTM A 216 GR.WCB	SS410	-	EPDM	#150	Flanged
2	Chemical dosing Lines(Acid, Sodium chlorite, chlorine dioxide etc.,)	CPVC Ball Valve (sch 80)	All size	CPVC	CPVC	CPVC	PTFE	PN16	Solvent cement Socket End
		CPVC Ball Check Valve (sch 80)	All size	CPVC	CPVC	---	EPDM	PN16	Solvent cement Socket End
3	Compressed air application	Ball Valve	≤50 NB	Galvanized cast carbon steel or Forged carbon steel	Stainless Steel / ANSI 420	Stainless Steel / ANSI 420	Nitrile Rubber / PTFE	#150	Flanged End / Screwed

	SPECIFICATION FOR CHLORINE-DI-OXIDE (ClO <sub>2</sub> ) GENERATOR	SPEC.NO.ROS: 6112
		REV.: 00

#### 4.7 PAINTING

The painting specification is enclosed as **Annexure-B**.

#### 4.8 VENDOR LIST FOR MECHANICAL ITEMS

The vendor list is enclosed with this specification as **Annexure-A**.  
EIL approved Vendor list shall be followed for various sub systems involved in Chlorine dioxide generator system.

	SPECIFICATION FOR CHLORINE-DI-OXIDE (ClO <sub>2</sub> ) GENERATOR	SPEC.NO.ROS: 6112
		REV.: 00

## 5.0 TECHNICAL SPECIFICATION FOR ELECTRICAL, CONTROLS & INSTRUMENTATION

Electrical, Controls & Instrumentation requirements for the ClO<sub>2</sub> system is attached separately as **ROS-4085** pages along with this specification.

## 6.0 TECHNICAL DETAILS FOR CIVIL WORKS:

Construction of shed/ room, foundation and flooring etc for the ClO<sub>2</sub> generator system is not in bidder scope. However the foundation materials like grouting mix, foundation bolts & packing shims etc, are in bidder's scope. The bidder shall provide the equipment layout drawing along with bid. Detailed construction drawing with foundation requirement like load details, foundation pockets etc, for all the skids, equipment, tanks, flooring requirements, trenches for pipe routing, cable routing & drains etc. shall be furnished to customer for further construction immediately after order.

Any special requirement like handling arrangement, floor / trench protection etc. shall also be indicated in the drawings. All the plant drains & trenches are to be connected in a common trench after sufficient dilution and terminated near Plant boundary. The approximate area & location are indicated in the enclosed lay out drawing. Bidder to accommodate the ClO<sub>2</sub> system with in the stipulated area only as indicated in the typical layout drawing attached along with this specification.

	<p style="text-align: center;">SPECIFICATION FOR CHLORINE-DI-OXIDE (ClO<sub>2</sub>) GENERATOR</p>	<p>SPEC.NO.ROS: 6112</p>
		<p>REV.: 00</p>

## 7.0 PERFORMANCE GUARANTEE

The system performance guarantees applicable are detailed in this section.

### 7.1 PERFORMANCE GUARANTEE

**7.1.1** The bidder shall guarantee all equipment for workmanship, materials and satisfactory performance. The guarantee for performance will cover individual items and systems including electrical for their ratings / outputs as well as for the integrated operation of equipment and its auxiliaries as a whole. On completion of satisfactory commissioning, the supplier shall conduct performance / acceptance tests on the equipment and system as a whole for demonstrating the guaranteed performance parameters specified. All instruments, gauges installed for the normal operation of equipment shall be made use of during the acceptance test as far as possible. If additional instruments are required for the tests, these shall be brought by supplier at free of cost and shall be taken back after performance test. The guarantee tests shall cover the following but not be limited to the rated parameters for smooth operation of complete ClO<sub>2</sub> system:

- a. ClO<sub>2</sub> generator capacity & dosage requirements as indicated in section 3.2
- b. Power consumption for continuous operating equipment as per **Annexure-2**
- c. Vibration and noise level of rotating equipment

**7.1.2** Minimum 72 hrs performance test run shall be conducted for the guaranteed values of treated water quality, quantity and other performance parameters.

### 7.2 General

In addition to the guarantees mentioned above, the requirements of specifications on all guarantees as elaborated under relevant clauses of Technical Specifications should be met.

## 8.0 SPARES:

### 8.1 Commissioning Spares:

The bidder should take care of this requirement for trouble free commissioning of the system since commissioning is under bidder's scope. The commissioning spares list shall be provided along with the offer. The requirements of spares are to be provided by the contractor within quoted lump sum price. Any unutilized commissioning spares shall be handed over to the purchaser. The commissioning spares shall be delivered well in time before the start-up & commissioning of the plant.

### 8.2 Mandatory Spares:

	<b>SPECIFICATION FOR CHLORINE-DI-OXIDE (ClO<sub>2</sub>) GENERATOR</b>	<b>SPEC.NO.ROS: 6112</b>
		<b>REV.: 00</b>

The mandatory spares shall be delivered along with the main supply. The Cost of mandatory spares shall be indicated separately and the same is considered for Bid Evaluation.

The lists of mandatory spares are given below:

**8.2.1 Horizontal Pumps** (HCl & Sodium chlorite unloading pumps):

SL. NO.	Name of Items	Qty	Remarks
1)	Mechanical seal	1 Sets	For each type

**8.2.2 Storage tanks** (HCl & Sodium chlorite bulk storage tanks):

SL. NO.	Name of Items	Quantity Required per Tank
1)	Bolting for each nozzle with blind/ companion flange	10% (min. 2nos.) for each nozzle
2)	Gaskets for each nozzle with blind/ companion flange	200%
3)	Bolting for internal flanges of each nozzle	One set for each nozzle
4)	Gasket for internal flanges of each nozzle	200%

For the list of mandatory spares for E, C & I portion, please refer electrical specification ROS-4085 & 4079.

**8.3 Recommended Spares:**

The bidder shall provide the list of recommended O&M spares for the first two years of normal operation to be filled as per **Annexure-5**. Customer reserves the right to buy any of the recommended spares as considered necessary by him during later stage. The price of recommended spares will not be considered for bid evaluation.

**9.0 ERECTION, COMMISSIONING, PG TEST & HANDING OVER:**

Erection, commissioning, PG test & Handing over for the ClO<sub>2</sub> generator system shall be as per the requirement mentioned elsewhere in the specification (ROS-9027).

	<p style="text-align: center;">SPECIFICATION FOR CHLORINE-DI-OXIDE (ClO<sub>2</sub>) GENERATOR</p>	<p>SPEC.NO.ROS: 6112</p>
		<p>REV.: 00</p>

## 10.0 DOCUMENTATION:

### 10.1 GENERAL:

The documentation during bid and post order stage shall meet the following requirements.

1. All documents and drawing shall be submitted in English
2. Hard copies of all documents and drawings during bid stage to be submitted in duplicate.
3. Hard copies of all documents for approval shall be submitted in triplicate.
4. Hard copies of all final documents, drawings, Erection and O& M manual etc., shall be submitted in bound folder in 6 copies.
5. Soft copies of all final documents in MS word / MS office in the form of CD –1 set
6. Soft copies of all final calculations in MS excel/ MS office in the form of CD–1set
7. Soft copies of all final drawings in Auto Cad, latest version in the form of CD-1set

### 10.2 DOCUMENTS ALONG WITH BID:

The following drawings / documents are to be enclosed along with the bid for scrutiny.

1. Technical write-up giving details of equipment operation, interlocks / control requirement.
2. Typical Quality Plan for major equipment (ClO<sub>2</sub> generator, pumps, tanks, dosing system, piping & valves etc.).
3. Process calculations.
4. Typical ClO<sub>2</sub> generator guarantee document.
5. Storage procedure before commissioning.
6. Datasheet for ClO<sub>2</sub> generator system
7. Preliminary P& I diagram
8. Preliminary Equipment layout drawing
9. Typical arrangement drawing & isometric drawing of skid with piping, valves, maintenance, walkway etc.,
10. Filled up data sheets as called in the specification – **Annexures 1 to 3**
11. Maintenance procedure
12. Utility requirements like instrument air, service air and service water for maintenance of the system.
13. Pump performance curves with marked duty point.
14. Sub vendor list for mechanical, electrical and C&I items.
15. Preliminary civil requirements.
16. PLC I/O list.

	<p style="text-align: center;">SPECIFICATION FOR CHLORINE-DI-OXIDE (ClO<sub>2</sub>) GENERATOR</p>	<p>SPEC.NO.ROS: 6112</p>
		<p>REV.: 00</p>

17. Tentative quantity of Power, Control and Screened cables to be supplied for the UF System by the Purchaser.
18. Deviation schedule duly filled, if any – **Annexure – 6**. Any deviation should have cost of withdrawal for our evaluation in the commercial bid.
19. Un-priced commercial offer on the scope of supply
20. Un-priced commercial offer for the recommended spares list

Bidder to note that failure to submit the above will be considered as incomplete and offer is liable for rejection.

Note:

1. In case of any deviation, the Bidder shall indicate the deviation, clause by clause in the deviation format attached in **Annexure - 6**. If there is no deviation “NIL” statement shall be furnished. In the absence of the non-attachment of this **Annexure-6**, it will be construed that the bid confirms strictly to the specification.

### 10.3 DOCUMENTS AFTER ORDER

#### 10.3.1 Phase-I (for approval-within 7 days from the date of LOI):

1. Technical Write-up and design basis
2. P&ID diagram including pipe sizes & terminal points.
3. Equipment layout showing building details, headroom, equipment.
4. Sizing, process calculations for equipment
5. Filled up datasheets for approval as per **Annexures 1 to 4**
6. ClO<sub>2</sub> generator system “Control Description” write-up including operation, controls, interlocks, protection, annunciation etc.
7. Activity chart / Bar Chart and schedules for drawing submission, manufacturing, erection and commissioning.
8. Quality Plan and field quality checks, stage inspection etc. (for ClO<sub>2</sub> generator, pumps, tanks, dosing system, piping & valves etc.,).
9. Guarantee Document.
10. Equipment Datasheet.
11. Performance curves for pumps & motors
  - a. Flow Vs Head
  - b. Flow Vs efficiency
  - c. Flow Vs Power
  - d. Flow Vs NPSH
12. Instrument schedule.
13. Typical arrangement drawing & isometric drawing of skid with piping, valves, headers arrangement including space for maintenance, walkway etc.,
14. Write-up about maintenance of equipment
15. PLC I/O list.

	SPECIFICATION FOR CHLORINE-DI-OXIDE (ClO <sub>2</sub> ) GENERATOR	SPEC.NO.ROS: 6112 REV.: 00
---	--	-------------------------------

### 10.3.2 Phase-II (for information-within 2 weeks from the date of LOI):

1. Storage procedure before commissioning
2. Piping and Valves schedule
4. Foundation Design drawings indicating foundation design, load data, anchor bolt location, pocket details, floor & trenches etc.
5. General arrangement drawings for all the equipment showing dimensions and details of materials.
6. **As-built manufacturing drawing of the skid frame and equipment, assembly including piping & valve system arrangements with Bill of material (BOM)**
7. Isometric drawing of pipe segments.
8. Cross sectional drawing of pump etc. with BOM
9. Details of pneumatic actuator

### 10.3.3 Phase-III (for information-before dispatch):

1. Erection Manual indicating
  - a. Erection/installation instructions of equipment.
  - b. Log sheet containing stage check parameters & clearance
  - c. Log sheets for alignment check of pump & motor
  - d. Field quality checks
2. Performance Test procedure
3. All the documents called in Electrical specification.
4. Shipping list for BHEL's approval in BHEL format

### 10.3.4 Phase-IV (for review):

1. Pump performance test reports
2. Pump performance guarantee certificates
3. Operation and maintenance manual indicating, Operating procedure for start-up, normal operation, shut down and emergency shutdown. (O & M manual shall be supplied with 6 sets of hard copies and one set in soft form in CD.
4. Maintenance instruction & assembly
5. Lubrication chart.
6. Electrical equipment layout, Cable trench layout, cable routing, cable schedules and cable termination details.
7. ClO<sub>2</sub> generator system Logic diagram & Sequential Flow Chart (SFC) for PLC.
8. Cable interconnection diagram for cables up to junction box & cable schedule.
9. Test Certificates for all the supplied instruments.
10. List of alarm, interlock & trip set points
11. Installation drawings for instruments

	<b>SPECIFICATION FOR CHLORINE-DI-OXIDE (ClO<sub>2</sub>) GENERATOR</b>	<b>SPEC.NO.ROS: 6112</b>
		<b>REV.: 00</b>

12. Wiring drawings & GA drawings for Local Panels, junction boxes.
13. As built drawings.
14. All other details called in Electrical specification.

**Note: Bidder to confirm in their offer that these details called in 10.3.1 & 10.3.2. will be provided.**

## **11.0 ATTACHMENTS**

**The following drawings enclosed are a part of the specification:**

1. PID for ClO<sub>2</sub> system : 1-WT-220-00370
2. ClO<sub>2</sub> system equipment layout : 1-WT-220-00378
3. Erection, commissioning, PG test & handing over specification no. ROS 9027, Rev 00
4. E, C & I specification no. ROS 4085, Rev 00
5. Electrical motor specification no. ROS 4079, Rev 00
6. Vendor list(Annexure-A)
7. Painting specification (Annexure-B)

## **12.0 IMPORTANT POINTS TO BIDDERS**

1. If the bidder has suggestions/requirements of any additional instruments/equipment over & above as shown in the P & ID drawing for the efficient functioning of the system, the same has to be clearly indicated and suitably covered in the commercial bid also separately.
2. The specification for the instruments/equipment available in the main specification has to be taken for such additional requirements (or) Customer should be contacted.

	<b>SPECIFICATION FOR CHLORINE-DI-OXIDE (ClO<sub>2</sub>) GENERATOR</b>	<b>SPEC.NO.ROS: 6112</b>
		<b>REV.: 00</b>

**Annexure-1**

**DATA SHEET**

**I CIO2 GENERATOR**

<b>Sl.No.</b>	<b>Description</b>	<b>Unit</b>	<b>Values</b>
1	ClO <sub>2</sub>	Kg/hr	
2	ClO <sub>2</sub> concentration	ppm	

**II CHEMICAL CONSUMPTION**

<b>Sl.No.</b>	<b>Description</b>	<b>Unit</b>	<b>Values</b>
1	HCl consumption	Kg/hr	
2	NaClO <sub>2</sub> consumption	Kg/hr	



SPECIFICATION FOR  
CHLORINE-DI-OXIDE (ClO<sub>2</sub>) GENERATOR

SPEC.NO.ROS: 6112

REV.: 00

Annexure-2

ELECTRICAL POWER CONSUMPTION

Sl. No.	Equipment Description	Qty		Pump efficiency	Drive rating KW	Conn load. Load KW	Power consumption KW	Voltage, Phase
		W	SB					
A	FOR CONTINUOUS OPERATING EQPT.							
1								
2								
3								
	Sub total of A							
B	FOR INTERMITTENT OPERATING EQPTS.							
1								
2								
3								
	Grand Total							

Note: W – Working

SB – Standby

	<b>SPECIFICATION FOR CHLORINE-DI-OXIDE (ClO<sub>2</sub>) GENERATOR</b>	<b>SPEC.NO.ROS: 6112</b>
		<b>REV.: 00</b>

**Annexure- 3**

**EQUIPMENT DATA SHEET FOR CHLORINE DIOXIDE SYSTEM**

**01. PUMPS** : **ClO<sub>2</sub> Diln Pump Unloading Pumps**

**I. TECHNICAL PARAMETERS**

**Dilution      HCl      NaClO<sub>2</sub>**

- a. Make :
- b. Model :
- c. Fluid details
  - Medium handled :
  - PH range :
  - TDS/Chloride range ppm :
  - Temperature range deg.C :
- d. Rated flow / Head (at Disch) m<sup>3</sup>/hr & mwc :
- e. Min. & Max continuous flow m<sup>3</sup>/hr :
- f. Corresponding discharge Head mwc :
- g. Shut-off head mwc :
- h. NPSH required (minimum) mwc :
- i. Design Pressure kg/cm<sup>2</sup> :
- j. Hydraulic test pressure kg/cm<sup>2</sup> :
- k. Pump efficiency at duty point % :
- l. BKW reqd. for pump at duty point kw :
- m. Maximum KW required kw :
- n. Recommended Motor KW kw :
- o. Rated speed rpm :
- p. Noise level at duty range dBA :
- q. Vibration level peak to peak mm :
- r. Balancing quality :

**II. CONSTRUCTION DETAILS**

- a. Orientation Horizontal / Vertical :
- b. Suction / Discharge nozzle
  - Size mm :





	<b>SPECIFICATION FOR CHLORINE-DI-OXIDE (ClO<sub>2</sub>) GENERATOR</b>	<b>SPEC.NO.ROS: 6112</b>
		<b>REV.: 00</b>

### 03. CHEMICAL DOSING SYSTEM (Acid, NaClO<sub>2</sub>)

#### I. Dosing Pump:

- a. Name of chemical dosing system : HCl NaClO<sub>2</sub>
- b. Make & Model No :
- c. Type :
- d. Flow
- Design Min / Max lph :
  - Rated Min / Max lph :
- e. Discharge Pres.
- Design Max kg/cm<sup>2</sup> (g) :
  - Rated Max kg/cm<sup>2</sup> (g) :
- f. Suction lift mwc :
- g. Stroke length Min / Max mm :
- h. Speed Min / Max rpm :
- i. Stroke adjustment Min / Max % :
- j. Flow Accuracy on design capacity % :
- l. Repeatability % :
- m. Power supply details V / Ph / Hz :
- Variation V / Ph / Hz % :
  - Power consumption watts :
- n. Material of construction
- Dosing Head :
  - Fittings :
  - Valve balls :
  - Spring in injection head :
  - Diaphragm :
  - Tubing :
  - Mounting Fasteners :
  - Other wetted parts :
- o. Normal operating life at design capacity :

	<b>SPECIFICATION FOR CHLORINE-DI-OXIDE (ClO<sub>2</sub>) GENERATOR</b>	<b>SPEC.NO.ROS: 6112</b>
		<b>REV.: 00</b>

- Diaphragm hrs :
- Ceramic balls hrs :
- p. Pump overall size L, W,H mm :
- q. Pump weight kg :
- r. Tube size :
- pressure rating at 20 deg.C kg/cm<sup>2</sup>(g) :
- Suction Inches : ID x OD
- Discharge Inches : ID x OD

**II. Accessories for Pump:**

- a. Anti-syphon / non-return valve :
- b. Air Release Valve :
- c. Pressure relief valve :
- d. Pump mounting fasteners :

**05. CHLORINE DIOXIDE GENERATOR SYSTEM:**

- a. Separate datasheet & process calculation for ClO<sub>2</sub> generator system shall be provided by bidder along with the technical offer.

	SPECIFICATION FOR CHLORINE-DI-OXIDE (ClO <sub>2</sub> ) GENERATOR	SPEC.NO.ROS: 6112
		REV.: 00

**Annexure - 4**

**VALVE SCHEDULE – DATA SHEET TO BE FILLED BY THE BIDDER**

Sl. No.	Service	Valve Type	Size	BODY	Disc / Ball / Diaphragm	Stem / Shaft	Valve seat / Seat ring	Hinge Pin	Valve Ends
1	<b>Manual valves</b>								
2	<b>Pneumatic Valves</b>								
3	<b>Check Valves</b>								





SPECIFICATION FOR  
CHLORINE-DI-OXIDE (ClO<sub>2</sub>) GENERATOR

SPEC.NO.ROS: 6112

REV.: 00

**ANNEXURE -6**

**TECHNICAL DEVIATIONS**

Sl. No	Section no.	Clause No.	Page / No.	Specification	Statement of Deviations/variations	Reason for Deviation

GENERAL											
1											
2	Project: <b>Dahej Petrochemical Complex</b>					Job No.: <b>6987</b>					
3	Owner: <b>ONGC Petro Additive Limited</b>					Site: <b>Dahej , Gujarat</b>					
4	Purchaser: Max./Min. Ambient °C:					Unit:		Unit No:			
5	Item No.:					Service:					
6	No. Reqd.:		Working:		Standby:		Parallel Operation Required:		<input type="checkbox"/> Yes	<input type="checkbox"/> No	
7	Applicable to <input checked="" type="checkbox"/> Proposal		<input type="checkbox"/> Purchase			<input type="checkbox"/> As Built					
8	<input checked="" type="checkbox"/> Scope option & Information specified by purchaser <input type="checkbox"/> Information Reqd. from & option left to vendor. Vendor to cross <input checked="" type="checkbox"/> the selected option.										
9	Driver: Working		Standby		Driver Supplied & Mounted By: <input type="checkbox"/> Pump Mfr. <input type="checkbox"/> Other						
10	<b>OPERATING CONDITIONS(Refer Process data sheet enclosed elsewhere)</b>										
11	Liquid Handled					Capacity (m <sup>3</sup> /hr): Min/Nor/Rated:					
12	Pumping Temp. (°C):		Normal		Max.		Discharge Pressure (kg/cm <sup>2</sup> ,A):				
13	Specific Gravity at P.T./15°C:					Suction Pressure: Nor./ Max. (kg/cm <sup>2</sup> ,A):					
14	Vapour Pressure at P.T. (kg/cm <sup>2</sup> ,A):					Diff. Pressure (kg/cm <sup>2</sup> ) @ Rated Capacity:					
15	Viscosity at P.T. (cP/est):		Corr./Eros. By:			Diff. Head (m) @ Rated Capacity:					
16	Solids in suspension		<input type="checkbox"/> Yes	<input type="checkbox"/> No	Size:		%		NPSH Available (m):		
17	<b>MANUFACTURERS SPECIFICATIONS</b>										
18	Pump Manufacturer:					Model No.:					
19	<b>CONSTRUCTION</b>					<b>PERFORMANCE</b>					
20	Casing Mounting: <input type="checkbox"/> Centerline <input type="checkbox"/> Foot <input type="checkbox"/> Inline					Proposal Curve No.					
21	Casing Split: <input type="checkbox"/> Axial <input checked="" type="checkbox"/> Radial					Visc. Corr. Factor: C <sub>0</sub> C <sub>Q</sub> C <sub>H</sub>					
22	Type: <input checked="" type="checkbox"/> Single Volute <input type="checkbox"/> Double Volute <input type="checkbox"/> Diffuser					NPSH Reqd. (Water) (m): F/L Speed (rpm):					
23	Casing Connection: <input checked="" type="checkbox"/> Vent <input checked="" type="checkbox"/> Drain <input type="checkbox"/> Gauge					No. of stages:		Efficiency (%):			
24	Nozzles		Size		ANSI Rating		Facing		Position		
						Rated BkW(0% Tol.):		kW		BKW @MCF(SG=1.0): kW	
25	Suction								Max.BKW rtd. Imp.: kW Rec. Driver Rating: kW		
26	Discharge								Max.head@ rtd imp.(m): Cap@ BEP(m <sup>3</sup> /hr):		
27	Imp. N (mm) Max:		Rated:		Min:		Type: <b>Closed</b>		MCF (m <sup>3</sup> /hr):Stable Thermal		
28	Brg.: Type/No. Radial:		Thrust:		Lub: <b>Oil</b>		M.A.W.P @ 15°C/P.T./Design Temp.(kg/cm <sup>2</sup> ,G):				
29	Cplg.:Make/Type: Fleximetl w spacer Nonspark Guard <input checked="" type="checkbox"/> Yes <input type="checkbox"/> No					Hydrostatic Test pressure (kg/cm <sup>2</sup> ,G):					
30	Driver Half cplg. mounted by: <input checked="" type="checkbox"/> Pump Mfr. <input type="checkbox"/> Others					Rotation facing coupling end: <input type="checkbox"/> CW <input type="checkbox"/> CCW					
31	Packing Type:		Size:		No. of rings:		Seal flush/ Quench plan:		Material:		
32	Mech. Seal: Make		Model:		API Code:		Ext. seal flush fluid:		LPM: @ Kg/cm <sup>2</sup> G/ EC		
33	Base Plate :		<input type="checkbox"/> Yes	<input type="checkbox"/> No	Fdn. Bolts: <input checked="" type="checkbox"/> Yes <input type="checkbox"/> No		Seal Barrier fluid:		LPM: @ Kg/cm <sup>2</sup> G/ EC		
34	Throat Bush: <input checked="" type="checkbox"/> Yes <input type="checkbox"/> No		Matl.:		Bal. Device: <input type="checkbox"/> Yes <input type="checkbox"/> No		Ext. quench fluid:		LPM: @ Kg/cm <sup>2</sup> G/ EC		
35	<b>Materials (API-610 Matl. Class)</b>			MOC		ASTM Grades		C.W. Plan :		LPM: @ Kg/cm <sup>2</sup> G/ EC	
36	I - Cast Iron (Ductile)		Casing				Weight(kg): Pump+Base+Coupling:		Driver:		
37	B - Bronze		Impeller				<b>AUXILIARY PIPING INTERFACE CONNECTIONS</b>				
38	S - Carbon Steel		Inner Case parts				(All interface conn.shall be termntd.with a flng. block valves)				
39	C - 11-13% Chr. Stl.		Sleeve Packed						<b>Size</b>		
40	h - Hardened		Sleeve Seal				Lantern Ring Inlet/Outlet		<b>Rating(ANSI)</b>		
41	f - Faced		Casing ring		H-BHN		Ext. Seal flush fluid Inlet/Outlet		<b>Facing</b>		
42	K -SS 304		Impeller ring		50(min)		Seal Quench fluid Inlet				
43	L -SS 316		Shaft				Seal pot vent/ drain				
44	X - AISI 410		Throttle Bush				Casing vent/ drain				
45	Y		Throat Bush				C.W Inlet/ Outlet				
46	Z		Balance Drum				Base plate drain (only flanged)				
47	<input type="checkbox"/> Driver suitable for Pump starting with open Disc. Valve condition.					Casing steam jacket					
48	<b>INSPECTION &amp; TESTS (EACH PUMP) (Also refer Engineering Design Basis)</b>										
49			Witness		Observe				Witness		
50	<input checked="" type="checkbox"/> Shop Test / Inspection		<input type="checkbox"/>		<input type="checkbox"/>		<input checked="" type="checkbox"/> NPSH As Reqd. <input checked="" type="checkbox"/> Per Spec. <input type="checkbox"/> Mandatory		<input checked="" type="checkbox"/>		
51	<input checked="" type="checkbox"/> Material Certificates		<input type="checkbox"/>		<input type="checkbox"/>		<input checked="" type="checkbox"/> Dismantle Insp. & Re-assembly after Test		<input checked="" type="checkbox"/>		
52	<input checked="" type="checkbox"/> Hydrostatic		<input checked="" type="checkbox"/>		<input type="checkbox"/>		<input type="checkbox"/> Unitisation/Dimensional Check		<input type="checkbox"/>		
53	<input checked="" type="checkbox"/> Performance/Sound Level		<input checked="" type="checkbox"/>		<input type="checkbox"/>		<input checked="" type="checkbox"/> Check for direction of rotation of pump & driver.		<input checked="" type="checkbox"/>		
54	<b>Applicable Specification: Engineering Design basis (6987-00-16-45-DB-01)</b>										
55	<b>REMARKS:-</b> 1) Max. allowable casing working pressure shall not be less than _____ kg/cm <sup>2</sup> g @ _____ °C. MAWP shall not be less than pressure temp. rating of ASME/ ANSI B16.1 Class 125 or ANSI B16.5 Class 150 flanges for the materials offered.										
56	2) Down Stream Design Pressure is _____ kg/cm <sup>2</sup> g. Maximum shut-off pressure considering max suction pressure and max specific gravity & including all tolerances shall not exceed this value.										
57	3) This is Typical datasheet , Contractor to fill for each item.										
58											

Date	Rev	Job Engineer	Reviewer	Approver

1	<b>GENERAL</b>			
2	Project: <b>Dahej Petrochemical Complex</b>		Job no.: <b>6987</b>	
3	Owner: <b>ONGC Petro Additives Limited</b>		Site: <b>Dahej, Gujarat</b>	
4	Purchaser:		Unit:	Unit no.:
5	Item No.:		Service:	
6	No. Required:	Working:	Std by:	Driver: Working: Std by:
7	Applicable to <input checked="" type="checkbox"/> Proposals		<input type="checkbox"/> Purchase <input type="checkbox"/> As Built	
8	<input checked="" type="checkbox"/> Scope Option & Information specified by Purchaser <input type="checkbox"/> Information required from & options left to vendor. Vendor to cross [:] the selected Option			
9	Manufacturer:		Size & Type:	Model:
10	<b>OPERATING CONDITIONS(Refer process data sheets enclosed elsewhere)</b>			
11	<input type="checkbox"/> Liquid:		<input type="checkbox"/> Capacity at PT (l/hr)/(m <sup>3</sup> /hr):	
12	<input type="checkbox"/> Pumping Temperature (EC)(Nor/Max.):		Min:	Nor: Rated:
13	<input type="checkbox"/> Specific Gravity at PT:		<input type="checkbox"/> Discharge Pressure (kg/cm <sup>2</sup> ,a):	
14	<input type="checkbox"/> Vapour Pressure at PT(kg/cm <sup>2</sup> ,a):		Min:	Nor: Rated:
15	<input type="checkbox"/> Viscosity at PT(Cp/Cst):		<input type="checkbox"/> Suction Pressure (kg/cm <sup>2</sup> ,a):	
16	<input type="checkbox"/> Corrosion Erosion caused by:		Min:	Nor: Rated:
17	<input type="checkbox"/> Presence of Solids:		<input type="checkbox"/> Differential Pressure (kg/cm <sup>2</sup> ):	
18	<input type="checkbox"/> NPSH Available (w/o acceleration head) (m):		Min:	Nor: Rated:
19	<b>SITE / INSTALLATION DATA(Refer enclosed elsewhere in the bid package..)</b>			
20	Location: <input type="checkbox"/> Indoor <input type="checkbox"/> Outdoor w/w/o roof		<input type="checkbox"/> Heated <input type="checkbox"/> Unheated	
21	Site Temperature(EC):		Max: Min:	<input type="checkbox"/> Elect. Area Hazard: Div: Class: Group:
22	<b>APPLICABLE CODES &amp; STANDARDS</b>			
23	<b>API STANDARD 675 &amp; Engineering Design Basis (6987-00-16-45-01)</b>			
24	<b>PERFORMANCE</b>			
25	<input type="checkbox"/> Number of feeds:		<input type="checkbox"/> Plunger Speed (stroke/min): (# 100)	
26	<input type="checkbox"/> Rated Capacity (l/hr)/ (m <sup>3</sup> /hr):		<input type="checkbox"/> Plunger Diameter (mm):	
27	<input type="checkbox"/> Acceleration Head (m):		<input type="checkbox"/> Cylinder Diameter (mm): <input type="checkbox"/> Length of Stroke (mm):	
28	<input type="checkbox"/> Plunger Linear speed (m/s):		<input type="checkbox"/> Pump Relief Valve Set Pressure (kg/cm <sup>2</sup> ,g):	
29	<input type="checkbox"/> Volumetric efficiency (%):[# 90%]		<input type="checkbox"/> Pump Head MAWP (kg/cm <sup>2</sup> ,g):	
30	<input type="checkbox"/> Mechanical Eff. (%): <input type="checkbox"/> Overall Eff. (%):		<input type="checkbox"/> Hydro test Pressure (kg/cm <sup>2</sup> ,g):	
31	<input type="checkbox"/> NPSH Required (m):		<input type="checkbox"/> Flow Repeatability:	
32	<input type="checkbox"/> BkW Rated (kW): <input type="checkbox"/> BkW at R.V. Set Pr.:		<input type="checkbox"/> Thrust on plunger (kgf):	
33	<input type="checkbox"/> Packing Type: <input type="checkbox"/> No. Of rings:		<input type="checkbox"/> Design Plunger Thrust (kgf):	
34	<b>CONSTRUCTON FEATURES</b>			
35	<b>Nozzles</b>		<b>Size / ANSI Rating</b>	<b>Facing</b>
36	Pump Suction			<b>Position</b>
37	Pump Discharge			
38	Suction Manifold (for multi head pumps)			
39	Discharge Manifold (for multi head pumps)			
40	Relief Valve	Inlet		
41		Outlet		
42	Pulsation	Inlet		
43		Outlet		
44	Pulsation	Inlet		
45		Outlet		
46	<b>LIQUID END</b>			
47	Type: <input type="checkbox"/> Diaphragm <input type="checkbox"/> Plunger	Valves per feed: <input checked="" type="checkbox"/> Suction:Two <input type="checkbox"/> Discharge:Two		
48	No. of Heads: <input type="checkbox"/> Simplex; <input type="checkbox"/> Duplex; <input type="checkbox"/> Multiplex		<input checked="" type="checkbox"/> Valve type: <b>Ball</b>	
49	Diaphragm Type: <input type="checkbox"/> Single <input type="checkbox"/> Double		<input type="checkbox"/> Sandwich	
50	<b>MATERIALS (Refer Process data Sheet)</b>			
51	<input type="checkbox"/> Liquid End:		<input type="checkbox"/> Packing:	
52	<input type="checkbox"/> Contour Plate:		<input type="checkbox"/> Valve:	
53	<input type="checkbox"/> Hydraulic Diaphragm:		<input type="checkbox"/> Valve Guide:	
54	<input type="checkbox"/> Plunger:		<input type="checkbox"/> Valve Body:	
55	<input type="checkbox"/> Lantern Ring:		<input type="checkbox"/> Valve Gasket:	
56	<input type="checkbox"/> Packing Gland:		<input type="checkbox"/> Relief Valve: Body:	
57	<input type="checkbox"/> Calibration Pot:		<input type="checkbox"/> Suction/Discharge Pulsation Dampener:	
58	<b>Remarks:</b>			
59				
60				

INSPECTION & TESTING(Remark-7)						
62	Description	Required	Witnessed	Description	Required	Witnessed
63	Hydrostatic	<input checked="" type="checkbox"/>	<input checked="" type="checkbox"/>	Material Certificates	<input checked="" type="checkbox"/>	--
64	Performance Test	<input checked="" type="checkbox"/>	<input checked="" type="checkbox"/>	Shop Inspection	<input checked="" type="checkbox"/>	<input type="checkbox"/>
65	Steady State Accr.	<input checked="" type="checkbox"/>	<input checked="" type="checkbox"/>	Dismantle & Insp. after test	<input checked="" type="checkbox"/>	<input checked="" type="checkbox"/>
66	Repeatability	<input checked="" type="checkbox"/>	<input checked="" type="checkbox"/>	R.V. Test (Mfr. shop)	<input checked="" type="checkbox"/>	<input checked="" type="checkbox"/>
67	Linearity	<input checked="" type="checkbox"/>	<input checked="" type="checkbox"/>	Diaphragm Rupture Detection (Functional)	<input checked="" type="checkbox"/>	<input checked="" type="checkbox"/>
68	<b>DRIVER</b>					
69	<input checked="" type="checkbox"/> Type of Driver:		<input checked="" type="checkbox"/> Elec. Motor:	<input type="checkbox"/> Steam Driven:	<input type="checkbox"/> Air Motor:	
70	<input type="checkbox"/> Driver Supplied & mounted by Pump Manufacturer			<input type="checkbox"/> Driver Supplied & mounted by others		
71	<input type="checkbox"/> Driver kW:		<input type="checkbox"/> Speed (rpm):			
72	<b>WEIGHTS</b>					
73	<input type="checkbox"/> Pump with Driver & Base Frame (Kg):			<input type="checkbox"/> Relief Valve (Kg):		
74	<input type="checkbox"/> Skid size (lxbxh) (m):			<input type="checkbox"/> Total Weight (Kg):		
75	<input type="checkbox"/> Suction Pulsation Dampener (Kg):			<input type="checkbox"/> Discharge Pulsation Dampener (Kg):		
76	<input type="checkbox"/> Skid Size (lxbxh) (m):			<input type="checkbox"/> Total Weight (Kg):		
77	<b>CONTROLS</b>					
78	<b>Type of Stroke Control:</b>					
79	<input checked="" type="checkbox"/> Manual <input type="checkbox"/> Automatic		<input type="checkbox"/> Remote		<input type="checkbox"/> Local	
80	<b>Signal:</b>					
81	<input type="checkbox"/> Pneumatic (kg/cm <sup>2</sup> g):		<input type="checkbox"/> Minimum:		<input type="checkbox"/> Maximum:	
82	<input type="checkbox"/> Electronic (mA):		<input type="checkbox"/> Minimum:		<input type="checkbox"/> Maximum:	
83	Remarks:					
84	<b>ACCESSORIES</b>					
85	<input checked="" type="checkbox"/> Speed Reducer supplied & mounted by Pump Manufacturer:			<input checked="" type="checkbox"/> Relief Valve supplied & mounted by Pump Manufacturer:		
86	Make:			Make:		
87	<input checked="" type="checkbox"/> Integral <input type="checkbox"/> Separate		<input type="checkbox"/> Internal <input type="checkbox"/> External		<input checked="" type="checkbox"/> External	
88	<input type="checkbox"/> Model <input type="checkbox"/> Gear Ratio:		<input checked="" type="checkbox"/> Suction and Discharge manifold piping supplied & mounted by Pump Manufacturer			
89	<input checked="" type="checkbox"/> Common Base Plate under: Pump, gear box & driver					
90	<input checked="" type="checkbox"/> Coupling supplied & mounted by Pump Manufacturer:			<input type="checkbox"/> Back Pressure Valve		
91	Make:			<input type="checkbox"/> Calibration Pot: <input type="checkbox"/> At Suction <input type="checkbox"/> At Discharge		
92	<input type="checkbox"/> Type:			<input type="checkbox"/> Common to all pump units		<input type="checkbox"/> Separate
93	<input checked="" type="checkbox"/> Gas Precharging Kit:			<input type="checkbox"/> With Level Gauge		
94				<input checked="" type="checkbox"/> Puls. Dampener (Suct) (Remark-3)		Type:
95				<input checked="" type="checkbox"/> Puls. Dampener (Disch) (Remark -4)		Type:
96				<input checked="" type="checkbox"/> Diaphragm Rupture Detection System with DPDT contacts:		
97	<b>REMARKS</b>					
98	1. Pump casing design pressure shall not be less than kg/cm <sup>2</sup> ,g @ °C					
99	2. Pump manufacturer shall supply & mount Calibration Pot, if the same is specified.					
100	3. Pump manufacturer shall supply & mount Suction pulsation dampener, if the same is required to reduce the NPSHR.					
101	4. Pump manufacturer shall supply & mount Discharge pulsation dampener to limit the pulsations within ±3%					
102	5. Equivalent Suction piping length (m): _____; Suction pipe diameter (mm): _____					
103	6. The pump manufacturer shall supply Controlled Volume pump unit complete with speed reducer, driver, suction pulsation dampener (if reqd. or specified), discharge pulsation dampener, suction & discharge manifold piping duly prefabricated for multi head - multi-head pumps, relief valves, instrumentation etc. all duly mounted on a single common base plate, in the pump manufacturer's shop manufacturer's shop prior to shop testing.					
104						
105						
106						
107	7. Refer Engineering Design Basis (Doc. No. 6987-00-16-45-DB-01).					
108						
109						
110						
111						
112						
113						
114						

Date	Rev	Job Engineer	Reviewer	Approver

98200-02Z-1M-1  
DRAWING NO.

ALL DIMENSIONS ARE IN MILLIMETRES

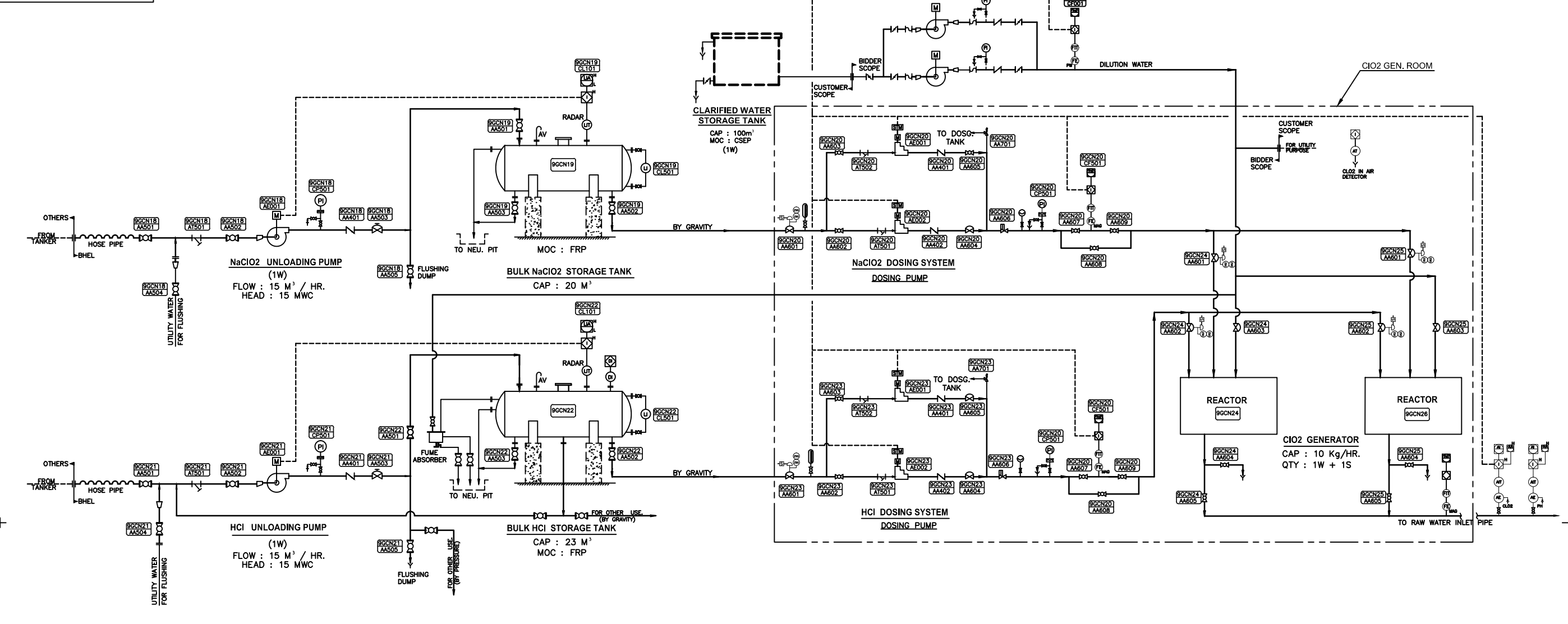

LEGEND : -

- HOSE PIPE
- BALL VALVE
- PRESSURE RELIEF VALVE
- NON RETURN VALVE
- DIAPHRAGM VALVE MANUAL
- DIAPHRAGM VALVE PNEUMATIC
- CENTRIFUGAL PUMP
- DOSING PUMP
- Y - TYPE STRAINER
- AIR VENT
- LEVEL INDICATOR
- LEVEL TRANSMITTER
- LEVEL SWITCH
- DENSITY INDICATOR
- CALIBRATION CYLINDER
- FLOW ELEMENT MAGNETIC
- FLOW ELEMENT PADDLE WHEEL
- FUME ABSORBER
- MOTORIZED
- STOKE CONTROLLED MOTOR
- DUMP
- PULSATION DAMPENER

KKS CODING SYSTEM

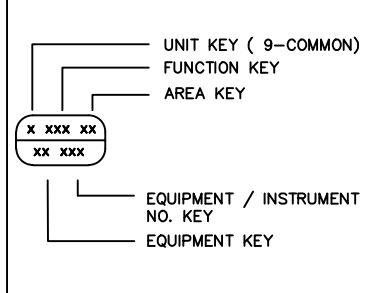

FUNCTION KEY

- GCB - CLARIFIER, PSF, ACF, UF & CF.
- GCF - CF OUTLET TO DM WATER TANK
- GCN - CC SYSTEM, DOSING SYSTEM
- GCP - REGENERATION, FLUSHING EQUIPMENT
- GCR - RESIDUAL REMOVAL & NEUTRALISATION
- GCS - CLARIFIER /UF SLUDGE DISPOSAL

EXAMPLE

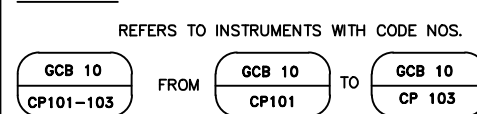

EQUIPMENT KEY

- AA - VALVES
- AE - MOTORS
- AH - HEATERS
- AM - MIXERS
- AT - FILTERING ELEMENT
- BN - EJECTOR
- CF - FLOW MEASUREMENT
- CP - PRESSURE MEASUREMENT
- CT - TEMPERATURE MEASUREMENT
- CQ - ANALYTICAL MEASUREMENT
- CL - LEVEL MEASUREMENT
- CD - DENSITY MEASUREMENT
- PD - DIFF. PR. MEASUREMENT

EQUIPMENT/INSTRUMENT NO. KEY

FIELD INSTRUMENTS :

- 001 TO 099 ANALOG INSTRUMENTS - REMOTE
- 101 TO 199 PROCESS SWITCHES - LOCAL
- 501 TO 599 PROCESS INDICATORS - LOCAL

VALVES :

- 051 TO 099 MOTORISED VALVE (INCHING DUTY)
- 101 TO 150 PNEU. ACTUATED VALVES
- 201 TO 299 SOLENOID OPERATED VALVES
- 401 TO 499 NON RETURN VALVES
- 501 TO 599 MANUAL VALVES - UF & RO SYSTEM
- 601 TO 699 MANUAL VALVES - MB, DOSING & CC SYSTEM
- 701 TO 799 PR. RELIEF VALVES

NOTES :

1. THE CAPACITIES SHOWN ARE MINIMUM AND INDICATIVE ONLY. BIDDER TO PROVIDE FINAL CAPACITIES TO MEET TECHNICAL SPECIFICATIONS AND SYSTEM GUARANTEE.
2. PIPE SIZE & MOC ARE INDICATIVE ONLY. BIDDER TO CONFIRM THE SIZE TO MEET THE VELOCITY GUIDELINES, MOC, ETC TO MEET TECHNICAL SPECIFICATIONS AND SYSTEM GUARANTEE.
3. UTILITY WATER IS SUPPLIED FROM CLARIFIED WATER STORAGE TANK

**FOR TENDER PURPOSE ONLY**

TYPE OF PRODUCT OR NAME OF CUSTOMER/PROJECT		RAW WATER TREATMENT PLANT ONGC PETRO additions LIMITED, VADODARA , INDIA			
DEPT NP CODE 976	GRADE OF UNTOLO.DIM PR:QA:500	SCALE	WEIGHT (KG)	REF. TO ASSY/OLD DRG.	REV NO. OF DRG.
	TITLE P & ID FOR CIO2 GENERATOR SYSTEM	CARD CODE U 01	DRAWING NO. 1-WT-220-00370	REV 00	

COPY RIGHT AND CONFIDENTIAL  
The information on this document is the property of Bharat Heavy Electricals Ltd. It must not be used directly or indirectly in any way detrimental to the interest of the company.

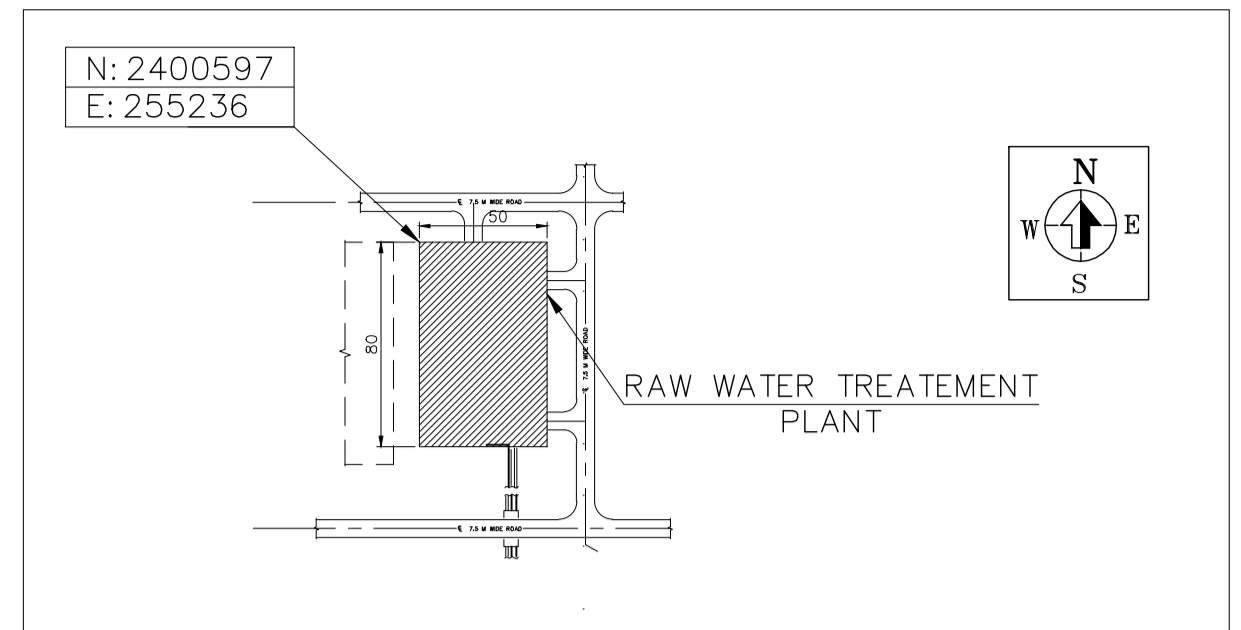
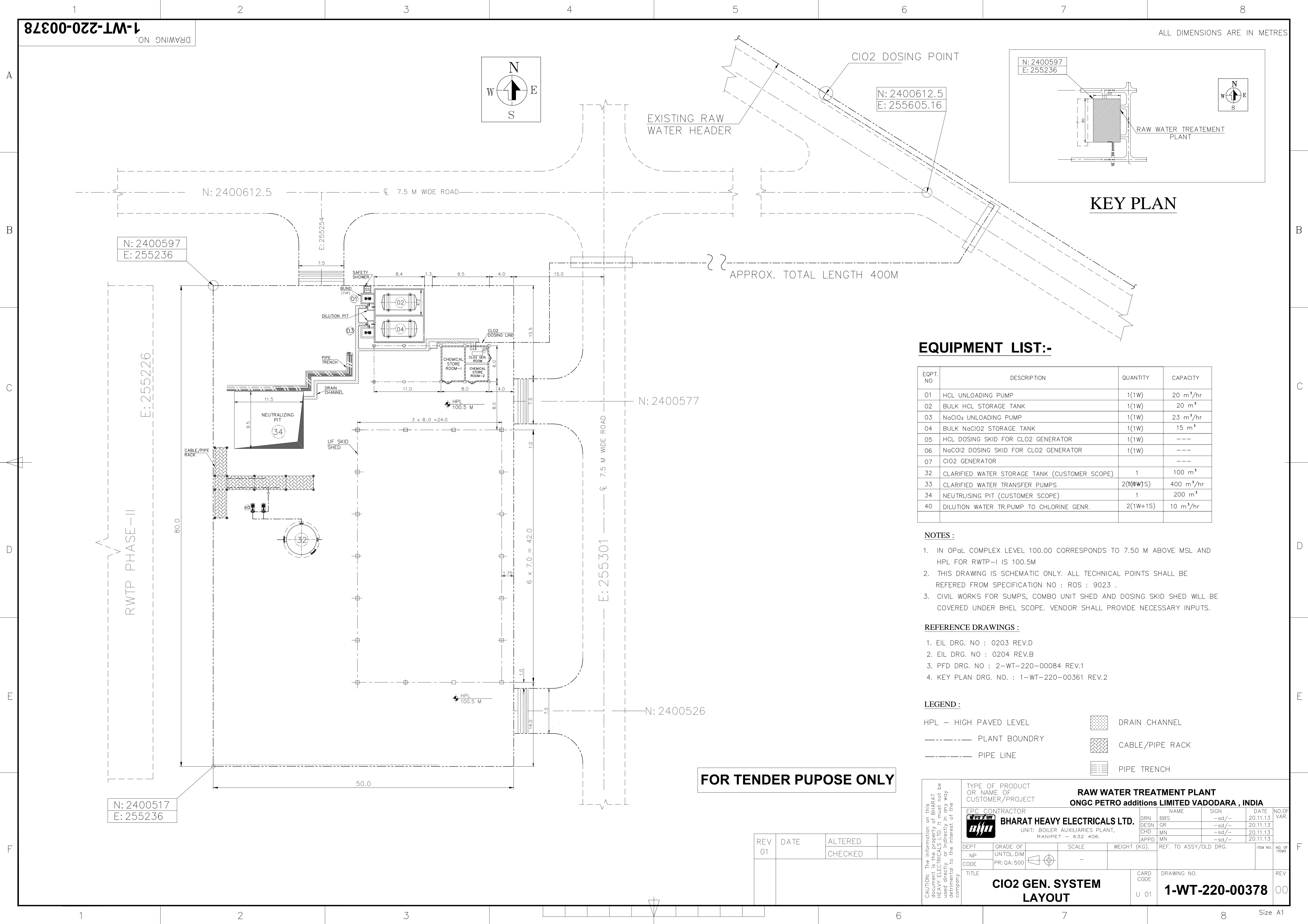

KEY PLAN

EQUIPMENT LIST:-

EQPT. NO	DESCRIPTION	QUANTITY	CAPACITY
01	HCL UNLOADING PUMP	1(1W)	20 m <sup>3</sup> /hr
02	BULK HCL STORAGE TANK	1(1W)	20 m <sup>3</sup>
03	NaClO <sub>2</sub> UNLOADING PUMP	1(1W)	23 m <sup>3</sup> /hr
04	BULK NaClO <sub>2</sub> STORAGE TANK	1(1W)	15 m <sup>3</sup>
05	HCL DOSING SKID FOR CLO <sub>2</sub> GENERATOR	1(1W)	---
06	NaClO <sub>2</sub> DOSING SKID FOR CLO <sub>2</sub> GENERATOR	1(1W)	---
07	CIO <sub>2</sub> GENERATOR	---	---
32	CLARIFIED WATER STORAGE TANK (CUSTOMER SCOPE)	1	100 m <sup>3</sup>
33	CLARIFIED WATER TRANSFER PUMPS	2(1(W)1(S))	400 m <sup>3</sup> /hr
34	NEUTRALISING PIT (CUSTOMER SCOPE)	1	200 m <sup>3</sup>
40	DILUTION WATER TR.PUMP TO CHLORINE GENR.	2(1W+1S)	10 m <sup>3</sup> /hr

NOTES :

- IN OPdL COMPLEX LEVEL 100.00 CORRESPONDS TO 7.50 M ABOVE MSL AND HPL FOR RWTP-I IS 100.5M
- THIS DRAWING IS SCHEMATIC ONLY. ALL TECHNICAL POINTS SHALL BE REFERRED FROM SPECIFICATION NO : ROS : 9023 .
- CIVIL WORKS FOR SUMPS, COMBO UNIT SHED AND DOSING SKID SHED WILL BE COVERED UNDER BHEL SCOPE. VENDOR SHALL PROVIDE NECESSARY INPUTS.

REFERENCE DRAWINGS :

- EIL DRG. NO : 0203 REV.D
- EIL DRG. NO : 0204 REV.B
- PFD DRG. NO : 2-WT-220-00084 REV.1
- KEY PLAN DRG. NO. : 1-WT-220-00361 REV.2

LEGEND :

- HPL - HIGH PAVED LEVEL
- PLANT BOUNDARY
- PIPE LINE
- DRAIN CHANNEL
- CABLE/PIPE RACK
- PIPE TRENCH

FOR TENDER PUPOSE ONLY

REV	DATE	ALTERED	CHECKED
01			

<p>CAUTION: The information on this document is the property of BHARAT HEAVY ELECTRICALS LTD. It must not be used directly or indirectly in any way without the interest of the company.</p>	TYPE OF PRODUCT OR NAME OF CUSTOMER/PROJECT <b>RAW WATER TREATMENT PLANT</b> <b>ONGC PETRO additions LIMITED VADODARA , INDIA</b>		
	EPC CONTRACTOR <b>BHARAT HEAVY ELECTRICALS LTD.</b> UNIT: BOILER AUXILIARIES PLANT, RANIPET - 632 406.	NAME SIGN DATE	NO. OF VAR. 20.11.13 20.11.13 20.11.13
	DEPT NP CODE	GRADE OF UNTOI.DIM PR:QA: 500	SCALE WEIGHT (KG). REF. TO ASSY/OLD DRG.
	TITLE <b>CIO2 GEN. SYSTEM LAYOUT</b>	CARD CODE U 01	DRAWING NO. <b>1-WT-220-00378</b>



**SECTION – 5 (Annexure to ROS 6112)**

**TECHNICAL SPECIFICATION FOR  
ELECTRICAL, CONTROLS & INSTRUMENTATION  
OPAL DAHEJ – CIO<sub>2</sub> GENERATION SYSTEM**

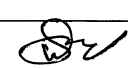
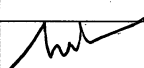
00	01.01.14	AT 	VNS 	SK 	Fresh issue
Rev.No	Date	Prepared	Checked	Approved	Remarks



**THIS DOCUMENT CONSISTS OF THE FOLLOWING SPECIFICATIONS:**

	PAGE NO:
<b>0.0 REFERRED PUBLICATIONS</b>	03
<b>1.0 GENERAL SPECIFICATION FOR E, C&amp;I</b>	05
1.1) E, C& I Scope System Activities	07
1.2) E, C& I Scope of Supply	08
1.3) E, C&I Scope of Work between BHEL & VENDOR	08
1.4) List of Drawings / Documents to be submitted along with offer	09
1.5). List of Drawings / Documents to be submitted after ordering	09
<b>2.0 Project Information</b>	10
3.0) Specification for LT Motors	10
3.1) Specification for Instruments	10
3.2) Specification for Instrument Signal Cable & power cable	25
3.3) Specification for Junction Boxes	28
3.4) Specification for solenoid valve enclosure box (sveb)	30
3.5) Specification for Cable trays, glands, fittings	31
3.6) Specification for Erection E,C&I Items	33
<b>4.0 Mandatory Spares</b>	35
<b>5.0 Commissioning Spares</b>	35
<b>6.0 Two years operational spare list</b>	35
<b>7.0 Commissioning</b>	36
<b>8.0 Customer Approved Vendor List (9 pages)</b>	36
<b>9.0 SCHEDULES</b>	36



## 0.0 REFERRED PUBLICATIONS

Design and terminology shall comply, as a minimum, with the latest edition prior to the date of purchaser's enquiry with following codes, standard practices and publications:-

AGA	American Gas Association
Report No.3 -	Orifice Metering of Natural Gas & other related hydrocarbon fluids
Report No.7 -	Measurement of Gas by Turbine Meters.
ANSI/ASME	American National Standards Institute/American Society of Mechanical Engineers.
B 1.20.1	Pipe Threads General Purpose (Inch)
B 16.5	Pipe Flanges and Flanged Fittings
B 16.20	Metallic Gaskets for pipe Flanges, Ring Joint, Spiral wound and Jacketed.
ANSI/FCI	American National Standards Institute/Fluid Control Institute
70.2	Control valve seat leakage classification
API	American Petroleum Institute
API 520	Sizing, selection and installation of pressure relieving devices in refineries.
Part-I	Sizing and selection
Part-II	Installation
API 521	Guide for pressure relieving and depressurising systems.
API 526	Flanged steel Pressure Relief Valves.
API 527	Seat tightness of Pressure Relief Valves.
API MPMS	Manual of Petroleum measurement standards.
API RP 551	Process Measurement Instrumentation
Part I -	Process Control and Instrumentation
API 522	Transmission Systems.
S 1101	Measurement of Petroleum Liquid Hydrocarbon by Positive Displacement meter.
S 2000	Venting Atmospheric and low-pressure storage tank non-refrigerated and refrigerated.
S 2534	Measurement of liquid hydrocarbons by turbine meter systems
S 670	Vibration, Axial-Position and Bearing-Temperature Monitoring
ASME	American Society of Mechanical Engineers
ASME Sec-VIII	Boiler and Pressure Vessels Code rules for construction of pressure vessels
ASME Sec-I	Boiler and Pressure Vessels Code. Section-I 'Power Boilers'
ASTM	American Society for Testing and Materials.
BIS	Bureau of Indian Standards
BS	British Standards
BS-5308 Part-II :	Specification for PVC insulated cables.
BS-7244	Flame Arrestors.
DIN	German Standards
DIN-43760	Temperature Vs Resistance curves for RTDs.
DIN-19234	Electrical Distance Sensors; DC interface for Distance Sensor and Signal Converter.
EN-10204	Inspection Documents for Metallic Products
IBR	Indian Boiler Regulations



**SPECIFICATION FOR ELECTRICAL  
CONTROL & INSTRUMENTATION**

**SPEC. NO.: ROS 4085**

**REV. NO: 00**

IEC	International Electro technical Commission
IEC 60079	Electrical Apparatus for Explosive Gas atmosphere
IEC 60085	Thermal Evaluation and Classification of Electrical Insulation.
IEC 60332	Test on bunched wires or cables.
Part III	Cat. A
IEC 60529	Degree of protection provided by enclosures.(IP code)
IEC 60534-2	Industrial Process Control Valves-Flow capacity.
IEC 60584-2	Thermocouple Tolerances
IEC 60751	Industrial Platinum Resistance Thermometer Sensors
IEC 61000-4	Electromagnetic compatibility for Industrial Process measurement and control equipment.
IEC 61158	Foundation Fieldbus Specifications
IS	Indian Standard
IS-5	Colours for ready mixed paints and enamels
IS-319	Specification for free cutting Brass bars, rods and sections
IS-1239	Mild steel tubes, tubulars and other wrought steel fittings.
IS-1271	Specification of Thermal Evaluation and Classification of Electrical Insulation
IS-1554	PVC insulated (heavy duty) electric cables working
Part I -	voltage up to and including 1100V
IS-2074	Ready mixed paints, air drying, red oxide - zinc chrome
IS-13947	Degree of Protection provided by Enclosures for Low Voltage Switchgears and Control gears. Part 1 General Rules.
IS-2148	Flame proof enclosures for electrical apparatus for Explosive Gas Atmospheres – Flameproof Enclosures ‘d’.
IS-3624	Specification for pressure and vacuum gauges
IS-5831	PVC insulation and sheath of electric cables.
IS-7358	Specifications for Thermocouples
IS-8784	Thermocouple compensating cables.
ISA	International Society of Automation
S-5.2	Binary logic diagrams for process operations.
S-7.3	Quality standard for instrument air
S-75.01	Flow equations for sizing control valves.
ISO 5167	Measurement of fluid flow by means of orifice plates, nozzles and venturi tubes inserted in circular cross-section conduits.
NACE	National Association of Corrosion Engineers
NEC	National Electric code
NEMA	National Electrical Manufacturer's Association
ICS-6	Enclosures for Industrial control and systems.
NFPA	National Fire Protection Association
NFPA-496	Purged and pressurized enclosures for electrical equipment.
OSHA	Occupational Safety and Health Authority.
SAMA	Scientific Apparatus Maker's Association



**1.0) GENERAL SPECIFICATION FOR ELECTRICAL, CONTROLS & INSTRUMENTATION:**

- a) ELECTRICAL, CONTROL & INSTRUMENTATION (E,C&I) scope of work by system vendor, scope of work between BHEL & VENDOR, Scope of supply for the system between BHEL and Vendor shall be as mentioned in this specification.
- b) The system vendor should furnish a " Write up on Control Description" explaining the controls, interlocks etc., for the system which have to be arranged by the purchaser in the PLC system. Necessary Valve Sequence Charts ,Logic Diagram control philosophy, list of interlocks etc., have to be furnished during detailed engineering to facilitate implementation of the system controls & interlocks in the PLC system.
- c) Based on the inputs furnished by system vendor, the PLC vendor will prepare the engineering software in the form of ladder diagrams for the system portion. The system vendor shall review and approve the ladder diagram for implementation. At this stage of checking & approval the system vendor should not call for any considerable number of additional I/Os over & above the I/O list given in his offer. Once the system requirements are implemented in the PLC system after vendor's review & approval, the responsibility for proper functioning of the entire system in Auto & Manual mode shall rest with the vendor.
- d) Analytical instruments for pH / ORP / Conductivity / Silica / Turbidity / TOC / Dissolved Oxygen /ClO<sub>2</sub> etc. as applicable shall consist of sensor & microprocessor based analyser which shall be located in the field. Only 4 - 20mA output signals from the analysers shall be brought to the PLC system where these parameters will be displayed on the PC screens using HMI software. Necessary calibration solutions / buffer powders / reagents etc. required for calibration & commissioning of analytical instruments shall be included by the vendor in his scope. The offer should include rates for such calibration solution / buffer powder / reagents and the periodicity and quantity requirement
- e) To facilitate operation of the system, valve operation shall be pneumatically operated. Accordingly vendor to indicate the Instrument air requirement taking into consideration that at a time all the working streams shall be operated
- f) All the instruments supplied by the vendor must meet BHEL's specification and will have to be procured from the approved vendors list only.
- g) All electrical equipment shall be suitable for the power supplies, fault levels and other climatic conditions indicated in "Project Information" enclosed with the specification.

**1.0.1 Additional requirements**

- a) During execution stage, the bidder shall assist BHEL for obtaining the approval for various drawings / data sheets / documents pertaining to this package by visiting customer's premises along with the buyer



**SPECIFICATION FOR ELECTRICAL  
CONTROL & INSTRUMENTATION**

**SPEC. NO.: ROS 4085**

**REV. NO: 00**

- b) All mounting accessories for various instruments shall be supplied as a part of basic scope of this package.
- c) After award of contract of bidder should submit the quality plan for BHEL approval for all the items covered in this package. O& M manuals for all the Instruments should be submitted in Hard & soft copies. (After award of contract)
- d) Erection hardware like root valves, impulse lines, 2 / 3 / 5 way manifold valves shall also be supplied as a part of basic scope of this package.
- e) All Electrical equipments and instruments shall be provided with suitable earthing terminals as per relevant IS standard.
- f) Instrument air will be made available at one point. Further distribution shall be taken care of by the system vendor.
- g) The specification for Instruments, cables, instrument accessories shall be as per enclosed specification.
- h) Tag numbering philosophy would be uniform for the entire plant. There would a single, unique tag for a given equipment / signal.
- i) After completion of all erection and commissioning works, the left out items/ spares / tools & tackles / calibration instruments etc. shall be handed over to BHEL site office.
- j) All instruments shall be type-tested type. Only type tested instruments shall be supplied.
- k) All instruments shall undergo all routine tests. Test / Calibration certificates for all supplies shall be furnished.

**1.0.2 GENERAL INSTRUCTIONS TO THE TENDERER**

- a) Vendor shall quote for complete work specified in the document. Incomplete quotations for the part of the work will not be considered even if the quoted rates / price is lower.
- b) The owner reserves the right to omit any one or more items of work at any time of the contact without assigning any reason what so ever.
- c) The vendor shall include all necessary commissioning spares in his basic scope of supply.
- d) Rate for erection, testing, commissioning and training shall be quoted separately, which shall be included in the basic scope.



## **1.1 ELECTRICAL AND C&I SYSTEM ACTIVITIES**

<b>SL. NO</b>	<b>ELECTRICAL, C&amp;I SYSTEM ACTIVITY BY THE VENDOR</b>
1	Design, Manufacture / procurement, testing at manufacturer's works, packing delivery of the instruments, Instrument cables, cable Trays & Junction Box to site for complete skid.
2	Obtaining approvals from end customer for the specification, makes, model numbers of the instruments, GA drawing,
3	Furnishing the Inputs required for LTMCC engineering such as Electrical Load list with KW rating, number of drives covering all dosing pumps, dosing mixers in BHEL Format.
4	Furnishing the Inputs required for PLC engineering such as Sequential Flow Chart, Control philosophy, Detailed IO list, Alarm list for the system
5	Furnishing the Interconnection drawing of Pneumatic Valves to Solenoid Valve Enclosure Box(SVEB's) in BHEL format.
6	Furnishing the data sheets for Instruments in BHEL Format.
8	Furnishing the GA drawings & Termination details of Junction Boxes(JB's),
9	Furnishing the Interconnection drawing of Instrument to Junction Box(JB's) in BHEL format.
9	Preparation of Instrument Hook-up & installation drawings
10	Supply of LT motor along with cable glands & lugs
11	Supply of instruments as per enclosed PID (1_WT_220_00_370) along with support structures for the complete ClO2 Generation System.
12	Supply of required Junction Boxes (JB's) along with support structures for all supplied instruments
13	Supply of Pneumatic Operated Valves (POV's )as per enclosed PID
14	Supply of Instrument Cables from instruments, POV's (limit switch, solenoids) to JB's
15	Supply of Cable Trays along with support structures (from Instruments to JB's and POV's to JB's)
16	Supply of Cable Glands, cable lugs for instruments, motors, Junction Boxes(JB's), Solenoid Valve Enclosure Boxes(SVEB's) including the cable glands & cable lugs for the incoming cables in BHEL scope.
17	Supply of Mandatory spares as per enclosed list.
18	Supply of Commissioning spares as per enclosed list.
19	Obtaining all necessary statutory clearance for the installation
20	Calibration of all instruments at site with standard calibration solutions & standard instruments
21	Supply of tools required for erection & commissioning of instrumentation system
22	Carrying out pre commissioning Checks & test at site
23	Commissioning and putting into satisfactory operation of all instruments at site including successful trial operation and handing over the system to end user (Customer)
24	Providing training to BHEL & End user (BHEL Customer) at site



**SPECIFICATION FOR ELECTRICAL  
CONTROL & INSTRUMENTATION**

**SPEC. NO.: ROS 4085**

**REV. NO: 00**

25	After commissioning the instruments to the satisfaction of the end user (Customer) the successful bidder shall extend support to BHEL & Customer for a period of three months from the date of commissioning for the following. a) Recalibration of all instruments b) Rectification / Repair / Replacement of defective components
26	Submission of Operation & Maintenance manual in required number of copies (06 no hard copy & Soft copy).
27	Furnishing unit price of various components for addition / deletion purpose for all components of instruments, erection accessories.

**1.2 ELECTRICAL AND C&I SCOPE OF SUPPLY**

The list of items to be included in bidder scope includes but not limited to the following.

SL. NO	ELECTRICAL, C&I SYSTEM
1	Supply of LT motor along with cable glands & lugs
2	Supply of instruments as per enclosed PID (1_WT_220_00_370) along with support structures for the complete Waste treatment plant including dosing skids for the same .
3	Supply of Junction Boxes (JB's) & Solenoid valve Enclosure Boxes(SVEB's) for grouping of Pneumatic Operated Valves and supply of solenoid valve for individual POV along with support structures for the respective instruments covered in Sl.No.2 & 3 above
4	Supply of required erection materials for Instruments impulse line (Root valves, 2 / 3 / 5 Way manifold for instruments, Drain valves, ½” SS316 SS Tube, SS Fittings, Perforated trays for impulse tube, supporting structure etc) covered in Sl.No 2

**1.3 ELECTRICAL AND C&I SCOPE OF WORK BETWEEN BHEL & VENDOR**

SL. NO	ELECTRICAL SYSTEM	ACTIVITY	AGENCY
1	SPECIAL CABLES(REFER NOTE 5)	SUPPLY ERECTION	VENDOR VENDOR
2	JUNCTION BOXES ( Purchaser will furnish the JB drg. DDE)	SUPPLY ERECTION	VENDOR VENDOR
3	LAYING & TERMINATION OF DIGITAL / ANALOG INSTRUMENT CABLES / CONTROL CABLES BETWEEN EQUIPMENT & JUNCTION BOXES.	SUPPLY ERECTION CHECKING	VENDOR VENDOR VENDOR
4	CABLING MATERIAL BETWEEN EQUIPMENT & JUNCTION BOX (CABLE TRAYS & ACCESSORIES)	SUPPLY ERECTION	VENDOR VENDOR
5	CABLE SCHEDULE & CABLE INTERCONNECTION DRG.(UPTO JB)	PREPARATION VETTING	VENDOR BHEL
6	CONTROLS AND INSTRUMENTATION (As per P & ID enclosed)	SUPPLY ERECTION COMMG.	VENDOR VENDOR VENDOR
	INSTRUMENT AIR LINE	SUPPLY	VENDOR



**SPECIFICATION FOR ELECTRICAL  
CONTROL & INSTRUMENTATION**

**SPEC. NO.: ROS 4085**

**REV. NO: 00**

	DISTRIBUTION	ERECTION COMMG.	VENDOR VENDOR
7	IMPULSE PIPING AND FITTINGS	SUPPLY ERECTION COMMG.	VENDOR VENDOR VENDOR
8	LOCAL PANEL FOR INSTRUMENTS, TRANSMITTER RACKS ETC.(IF APPLICABLE)	SUPPLY ERECTION COMMG.	VENDOR VENDOR VENDOR
9	CALIBRATION OF INSTRUMENTS		VENDOR

**NOTES:**

1. Necessary layout inputs shall be given for BHEL supplied equipments.
2. Cable gland & Lugs shall be provided by vendor for equipment supplied by vendor.
3. Cable glands shall be matching to cable sizes where cables are supplied by purchaser. Cable sizes shall be furnished to the vendor at detailed Engineering stage.
4. Necessary layout inputs shall be given for BHEL supplied equipments.
5. Cables other than Power, Control & Screened control cables are special cables (cable between sensor & analyser).
6. Erection of cables beyond junction boxes shall be in purchaser's scope.
7. Termination of cables at Vendor supplied equipments by vendor, upto Junction Box.
8. All field instruments and junction boxes shall be provided with prefabricated canopy made of GI sheet with bolted construction.

**1.4 List of drawings / documents to be submitted along with offer.**

The bidder shall submit the following documents along with the offer:

1. Signed conformation of BHEL specification in total for the subject enquiry.
2. Instrument Schedule indicating instrument type, location, Quantity, operating parameters, measuring range, Makes in BHEL Format
3. Vendor P & ID
4. I / O list with number of DI, DO, AI, AO required for entire package
5. Electrical Load List indicating KW rating and no. of drives shall be furnished along with offer
6. Unit price for addition / deletion purposes during detailed design commissioning at site (in a separate sealed cover).
7. Schedule of Technical Confirmations – Schedule-A
8. Schedule of Technical deviations(if any) – Schedule-B

**1.5 List of drawings / data sheet to be submitted after placement of purchase order for the approval of the Purchaser, for all items under the scope of supply:**

- a. Data Sheet for Medium Voltage Squirrel Cage Induction Motor as per enclosed format 6987-017-16-50-DS-08 Rev. 0(2pages)
- b. Detailed I / O list
- c. Data Sheet for Instrument signal Cables, Instrument power cables.
- d. Type and quantity of cable trays supplied.
- e. Erection manual/ procedure (in english).
- f. O&M manual 6 copies of all items (for information).
- g. Technical data sheet for all instruments supplied in BHEL Format
- h. List of commissioning spares



- i List of Tools & tackles
- j List of calibration tools & Instruments
- k Dimensional drawings, mounting / installation drawings, materials of construction, Terminal Drawing for Junction Boxes supplied
- l Dimensional drawings, mounting / installation drawings, materials of construction, Terminal Drawing for Solenoid Valve Enclosure Boxes supplied
- m Test certificates for all supplied items including but not limited to Instruments, cables, Junction Boxes, Solenoid valve Enclosure Boxes, VFD panels(if applicable).
- n Instruments, POV's Installation ,Hook up drawings for all items.

## **2.0 PROJECT INFORMATION:**

Customer: ONGC Petro Additions Ltd  
Consultant: Engineers India Ltd  
Location: Dahej, Gujarat

### **Site conditions**

Equipment design temperature (IS-9676) : 45°C  
Minimum /Maximum Ambient Temperature : 5.6°C/ 47°C  
Relative Humidity : 89%  
Altitude above mean sea level : Less than 1000m above mean sea level  
Seismic Zone :As per IS-1893-ZONE-III  
Classification of Area : Non Hazardous Area  
Atmosphere : Dusty, tropical and corrosive as found in hydrocarbon industry  
Area Classification : All field Instrumentation including junction boxes shall be weatherproof and suitable for safe area.

## **3.0 Specification for LT Motors**

The specification for LT motors shall be referred in enclosed specification **ROS 4079** and the referred customer specification enclosed therein as a minimum requirement.

## **3.1 Specification for Instruments**

The specification shall be read along with enclosed customer specification and the vendor shall comply to these specifications as a minimum requirement.

All instruments and equipments shall be suitable for use in a hot, humid and tropical industrial climate in which corrosive gases and/or chemicals may be present. As a minimum, all instruments and enclosures in field shall be metallic type and dust proof and weatherproof to IP-55 as per IEC-60529/IS-13947 and secure against the ingress of fumes, dampness, insects and vermin. All external surfaces shall be suitably treated to provide protection against corrosive plant atmosphere.

In case of contradiction between licensor specifications and this Design Philosophy, licensor specifications shall prevail unless waiver to that specific requirement has been identified in the job specifications. In case, job specifications categorically identifies requirement, which is in contradiction to this, job specifications will prevail. All transmitters, instruments and instrument connections should generally be accessible from the ground or permanent platforms.



## SPECIFICATION FOR ELECTRICAL CONTROL & INSTRUMENTATION

SPEC. NO.: ROS 4085

REV. NO: 00

The design of electronic instruments shall be in compliance with the electromagnetic compatibility requirements as per IEC 61000-4 'Electromagnetic compatibility for Industrial Process measurement and Control equipment'.

All transmitters shall be provided with canopy. Canopy wherever used shall be pre-fabricated. All terminals shall be screwless clamp type of Phoenix, Wago or Weidmuller make.

All online process analysers shall be supplied with built-in Auto calibration without operator intervention, complete with required calibration apparatus/ calibration gas cylinders etc. Each analyser shall be complete with fault and maintenance contacts to advise analyser status in the DCS.

Vendor to consider 1/4" OD SS tubes and fittings such as male connectors etc. for 1/4" OD size even though 6 mm OD is indicated in the tubing hookups attached. Please refer the **EIL installation & hook up drawing** as attached.

Following units of measurement shall be applicable, unless indicated specifically otherwise;

Flow Liquid	: m <sup>3</sup> /h
Gas and Vapour	: Nm <sup>3</sup> /h
Pressure/Vacuum Gauge	: kg/cm <sup>2</sup> g : mm of H <sub>2</sub> O
Temperature	: deg C
Level	: %
Analysis	: % : ppm
Conductivity	: μS (micro siemens)

Ranges for instruments shall be selected in general, such that in normal process operation the indication is between 40% to 60% of span for linear and 60% to 80% of span for square root inputs. The set range for field instruments shall be 1.1 times the maximum process value or 1.4 times the operating process value whichever is higher rounded to the nearest ten.

Ranges for process switches shall be selected, in general, such that the set point falls preferably in the middle 30% of full adjustable range i.e. the set point shall fall between 35% and 65% of adjustable range.

Unless specified otherwise, the instruments shall have an over-range protection of at least 130% of range or maximum/ design pressure, whichever is higher, as a minimum.

All field instruments and junction boxes shall be provided with prefabricated canopy made of GI sheet with bolted construction.

Following power supply voltage levels shall be used, unless otherwise specified:

- For Analyzers like pH,ORP,CIO<sub>2</sub> etc : 110 V AC± 10%(UPS) 50Hz ±3Hz.
- Solenoid Valves for Pneumatic Valves voltage: 110 VAC ±10% 50Hz ±3Hz.,
- Field Instruments like Pressure, Differential Pressure, Temperature, Flow etc. voltage: 24 VDC ±10%.

Solenoid coils shall be rated for continuous operation of the upper limit of supply voltage!

### 3.1.1 Field Transmitters/ Meter Electronics

Field transmitters for flow, pressure, differential pressure , level , CIO<sub>2</sub> gas detector or density indicator transmitter shall be yoke mounted type unless specified otherwise. Meter electronics is used for flow measurement for inline meter, level measurement, analysers,



etc. and shall include all the associated items like pre-amplifier, converter, transmitter, integrator, integral output meter etc.

Field transmitter shall be intrinsically safe and meter electronics shall be intrinsically safe, in general. In case, intrinsically safe is not available from the approved vendor list enclosed with this FEED, flameproof enclosure is acceptable. In case sensor/ pick up coil is intrinsically safe, suitable barrier shall be provided and installed in flameproof enclosure.

These transmitters shall be 2 wire system having 4 - 20 mA DC output with superimposed digital signal having simultaneous analog and digital communication with HART communication protocol, unless otherwise specified.

The transmitter shall be microprocessor based and it shall incorporate a non-volatile memory which shall store complete configuration data of transmitter and sensor characterisation. All necessary signal conversions, including conversion to produce output with the required protocol shall be carried out in the transmitter electronics. The configurationally data of the instruments shall be stored in a non-volatile memory such that this remains unchanged because of power fluctuations or power off condition. In case vendor standard instrument has battery backed RAM, Vendor to ensure that battery drain alarm is provided as diagnostic maintenance message.

Transmitter shall also run complete diagnostic subroutines and shall provide diagnostic alarm messages for sensor as well as transmitter healthiness. In the event of detection failure, the output shall be driven to a predefined value, which shall be field configurable.

Accuracy of transmitters, smart as well as field bus based, shall be as follows:

Type of Transmitter	Range of Transmitter	Accuracy
Direct	760 mm WC and above	Equal to or better than $\pm 0.075\%$
Direct	Less than 760 mm WC	Equal to or better than $\pm 0.15\%$
Diaphragm seal	500 mm WC and above	Equal to or better than $\pm 0.25\%$
Diaphragm seal	Less than 500 mm WC	Equal to or better than $\pm 0.5\%$

The accuracy is defined as the combined effect of repeatability, linearity and hysteresis. The stability of the transmitters shall be equal to or better than  $\pm 0.1\%$  of span for a period of minimum 6 months, as a minimum.

Transmitter shall update the output at least 8 times a second unless otherwise specified. Unless specified otherwise in purchaser's specification, transmitter response time shall be as follows:

a) For transmitter range of 760 mm WC and above, the response time shall be equal to or better than 500 milliseconds.

b) For transmitter range below 760mm WC, the response shall be equal to or better than 1 second. The response time of the transmitter shall be considered as the sum of dead time and 63.2% step response time of the transmitter. The response time of transmitters shall commensurate with process. It shall be equal or better than the half of the scan time of control loop specified elsewhere in the bid package.

Unless specified otherwise, the over-range/static pressure protection of the transmitter shall be as follows;

However if the Over range/ static pressure value specified above is less than the maximum/ design pressure of service conditions, offered instrument shall be suitable for the maximum/ design pressure.

In the transmitter, the 'WRITE' option shall be protected through password.

### **3.1.2 Pressure Instruments (Pressure Gauges)**

a) Pressure gauges shall be weatherproof to IP 55 as per IEC 60529 / IS 13947, as a minimum, with dial size of 150 mm and shall have screwed bezels. Pressure gauge sensing element shall be an elastic element like bourdon tube, bellow, diaphragm etc. of SS316 and movement of Stainless steel, as a minimum. The design of pressure gauges shall conform to IS-3624. Case material shall be SS304 and vapor-tight.

b) Dial markings and dial colour shall be as per IS 3624. The pointer stops shall be provided at both ends of the scale to restrict the pointer motion beyond 5% above the maximum of scale and less than 5% below the minimum of the scale. Pointers shall



have external micrometer adjustment for gauge zero adjustment.

c) Unless otherwise specified, the accuracy including repeatability and hysteresis shall be  $\pm 1\%$  of full scale for Direct pressure gauges,  $\pm 2\%$  of full scale for Chemical seal type pressure gauges and for Differential pressure gauges.

d) Whenever the maximum pressure specified in the data sheet exceeds the over range protection pressure, over range protector shall be provided. In case of pressure gauges with diaphragm seal, same shall be installed between the seal and the gauge. Snubbers/pulsation dampners/gauge sever of SS304 shall be used for all pulsating services. These shall be floating pin type, externally mounted and externally adjustable. Over range protector and Snubbers, whenever used, shall be same as socket material, as a minimum.

e) Where vibrations and pressure fluctuations are expected, Glycerin filled type shall be used. In case of vibrating services like pump outlets, flexible armored hoses shall be used in place of impulse piping and gauges shall be mounted on separate stanchions.

f) Bourdon element shall be welded to socket and tip end shall be stress relieved.

g) Pressure gauges with range as 0 to 100kg/cm<sup>2</sup>g and above shall have safety type solid front case. Unless specified otherwise, the pressure gauges shall have an over-range protection of at least 130% of maximum working pressure, as a minimum.

h) Process connection shall normally be 1/2" NPTM bottom.

i) Sensing element for Draft gauges shall be suitable to measure the draft ranges such as capsule, bellows.

j) All pressure instruments shall be provided with 2- valve manifolds along with prefabricated hook ups made of SS316.

k) All Differential pressure gauges shall be provided with 3-way manifold of SS316. It shall be suitable for mounting on 2" pipe. Mounting accessories shall be provided with gauge.

l) All differential pressure gauges shall be of magnetic piston type. Alternatively DP transmitter with local indication shall be provided.

m) All gauges shall be provided with a blow out device i.e. blow out disc of aperture not less than 25mm for gauges with dial size 100mm and above, while 20mm for gauges with dial size less than 100mm.

n) Diaphragm seal pressure gauge with capillary shall be used for congealing and high viscous services or corrosive fluid, i.e where plugging of the element may occur or where suitable material is not available in highly corrosive service and where an element protection is necessary or where plugging of element may occur.. Size of the capillary shall be selected to ensure response time of the gauge better than 5 seconds.

For diaphragm seal pressure gauges with flanged ends, the diaphragm shall be rated for the maximum allowable pressure of the associated flange and spacer ring, isolation valve and plugs shall be provided.

The process connection shall be 1½" flanged for all application except where line size is below 1", chemical seal type pressure gauges with ½"NPT connection are acceptable for 1" below line size..

o) Receiver pressure gauges for local transmitter output indication shall have 100 mm dial with stainless steel element and 1/4" NPTM instrument connection.

p) The dial cover shall be made out of shatter proof glass sheet of thickness 1.5 to 3mm for gauges with dial size less than 100mm while minimum 3.0mm for gauges with dial size 100mm or greater.

q) The gauge socket shall be in one piece without any capillary or tube in between for bourdon tube type element and for others tubing with minimum bore of 3 millimetres is acceptable. Socket shall be welded type only.

### **3.1.3 Level Instruments**

#### **Level standpipe philosophy**



**SPECIFICATION FOR ELECTRICAL CONTROL & INSTRUMENTATION**

**SPEC. NO.: ROS 4085**

**REV. NO: 00**

The usage of standpipe shall be considered for clean, non-viscous and non-crystallizing services. The size of standpipe shall be 2" NB minimum. Separate isolation valve to be considered for standpipe unless otherwise specified by licensor.

Standpipe shall be used if there are more than 4 nozzles required for level instruments.

Maximum number of nozzles on the standpipe shall be limited as follows:

i) to 8 with no displacer type/ guided wave radar type level instrument on it.

ii) To 6 with displacer type/ guided wave radar type level instrument on it.

Multiple level gauges shall be used for visible lengths more than 1470 mm.

Separate standpipe shall be used for boot interface level measurement in addition to standpipe for the horizontal vessel.

Please refer the **EIL installation & hook drawing** as attached.

**3.1.3.1 Level Gauges- Float & Board type**

FUNCTION	INDICATE, LEVEL MEASUREMENT OF LIQUID
TYPE-CONSTRUCTION	GUIDED- DIRECT INDICATION
MEASURING RANGE	DDE
FLOAT	SS316
FLOAT WIRE ROPE	Ø1.6MM SS 316 (MULTISTRAND)
GUIDE WIRE ROPE	Ø1.6MM SS 316 (MULTISTRAND)
ANCHOR PLATE	SS316
NAME PLATE & TAG	SS
MOC OF ACCESSORIES FOR GAUGE	SUITABLE FOR SEASHORE ENVIRONMENT
PROCESS CONNECTION	3 Nos of 25 NB ANSI B 16.5 150# SOFF FLANGE, SS
LEAST COUNT	5 MM
CALIBRATED GAUGE BOARD	6" WIDE X AL WHITE POWDER COATING WITH BLACK GRADUATIONS & NUMERICALS
ACCESSORIES FOR GAUGE	SUITABLE FOR SEASHORE ENVIRONMENT
PROTECTION CONDUIT	STEEL PIPE (CAD.PLATED) 3/4" NB X 650mmL + 40mm (ADJ.)
SPRING TENSIONER ASSLY.	STEEL SPRING HOUSED IN STEEL ENCLOSURE (CAD.PLATED)

**3.1.3.2 Level gauges -Tubular**

Magnetic level gauges shall be used for in general. Only where the same is not suitable, gauge glasses shall be used. Gauge glasses shall generally be steel armoured reflex or transparent type.

a) All gauge glasses shall be steel armoured reflex or transparent type with body and cover material of forged carbon steel as a minimum and shall have toughened borosilicate glass with asbestos free gasket. Transparent type of gauges shall be provided with integral illuminators operating at 230 V 50 Hz single phase supply and suitable for electrical area



**SPECIFICATION FOR ELECTRICAL  
CONTROL & INSTRUMENTATION**

**SPEC. NO.: ROS 4085**

**REV. NO: 00**

classification specified. Multiple illuminators in gauge shall be wired internally using armoured cables and suitable glands. The incoming power terminals shall be suitable for cable connection upto 4.0 mm<sup>2</sup> size. All gauge glasses must have a rating equal to or more than the vessel design pressure and temperature.

b) Reflex type shall be used for clean and colourless liquids, for liquid level interface.

For low temperature, low boiling point service, large chamber type will be used.

Transparent type will be used on acid, caustic, dirty or viscous, coloured liquids and liquid interface. Transparent type with Mica or Kel-F shields shall be used for treated water, boiler and condensate services, and for corrosive liquids, which will attack glass. They may be used for non-hazardous services at ambient temperature and low pressures.

c) Large chamber gauges with anti-frost extension shall be provided for cold services below 0 deg C with extension material as Perspex or equivalent. Heating jacket shall be provided for viscous liquids.

d) In general, all gauges shall have top and bottom chamber connections, unless otherwise specified. In addition each gauge shall be provided with ball check valves and pipe union.

e) The visible range of level gauge shall be selected to cover the complete operating level as well as measuring range of the other level instruments provided for the same purpose. In general, the visible length of the level gauges shall be selected from the following:

Visible length, mm	Centre to Centre Length, mm
220	470
470	720
720	970
980	1230
1230	1480
1490	1740

In any case, the maximum visibility length shall not exceed 1500 mm for a single gauge. Multiple gauges with overlapping range shall be used for such cases.

f) Testing requirements - The gauge glasses shall be of heavy armour design and shall meet the following test pressures as a minimum: Gauge glasses (transparent type) in corrosive service shall be provided with glass protective shield/liners suitable for the process fluid being handled.

g) Gauge cocks shall be of the quick-closing, offset type with bolted bonnet, outside screw and with renewable seats. All moving and wetted internals like ball check seat, stem etc. shall be SS316, as a minimum.. Primary isolation valves are normally required in addition to the gauge glass cocks, except on vented tanks containing harmless liquids. Where the process fluid tends to foul the cocks internals and create plugging or where leakage is a problem, gauge valve may be eliminated. On low temperature service, with liquids having very high vapour pressure at ambient temperature, safety valve shall be provided at the vent connection of the gauge glass.

h) For level gauging in very viscous liquids, liquids with crystals, sour services and pressure above 600#, toxic services, float operated magnetic gauges with 2" flanged end connections shall be used. The float and chamber material shall be non-magnetic type with material of SS316L, as a minimum, and magnetic properties of the applicable parts shall not degrade under the influence of the design temperatures. For external mounted magnetic level instruments, the rolling magnet type of indication with red and yellow colour (with red colour indicating the level) or Ball-follower type of indicator shall be provided. Measuring scale shall be linear type. Accuracy and scale resolution shall be better than  $\pm 10$  mm. C-C to distance shall be 2000 mm, maximum.

i) Bicolor type level gauges shall be used for steam drums.

j) Where side-side connections are specified, the gauge shall have two entries, 180 degrees apart at each end with one side plugged.



### **3.1.3.3 Level Transmitter**

- a) Generally Guided Wave Radar type instruments shall be used for level measurement upto 1219 mm.
- b) Differential pressure transmitter shall be used for level measurement above 1219 mm and for services requiring purge or where liquid might boil in external portion.
- c) Internal displacer type of level transmitters shall be avoided unless application necessitates its use. Displacer type of level instruments shall be used for interface applications upto 1219mm, and where guided wave radar type level instruments are not suitable. All displacer type of level transmitters shall be of torque tube type with torque tube material of inconel, as a minimum.
- d) Non-contact type level transmitters may be used on corrosive, congealing, slurry services or services with varying density where diaphragm seal type transmitter cannot be used. Only ultrasonic or radar type level instruments shall be used for all acid and alkali tanks. Radar Gauges used on tanks shall have inventory capabilities.
- e) Differential pressure transmitter shall be used for level measurement above 1500 mm, for services requiring purge or where liquid might boil in external portion.
- f) Differential Pressure transmitters for use on corrosive or fouling service shall generally be diaphragm wafer with extended filled capillary type. Flush or extended diaphragm type differential pressure transmitter shall be considered for special applications only. Diaphragm material shall normally be stainless steel or any other special alloy.
- g) Magnetic Level instruments shall have Float failure indication and their accuracy and scale resolution shall be better than  $\pm 10$  mm.

### **3.1.3.4 Guided Wave Radar & Ultrasonic Level Instruments**

- a) Guided Wave Radar type Level Instrument shall be based on Time Domain Reflectometry (TDR) principle with type of wave guide i.e. coaxial/ twin rod/ singlerod selected by the Vendor . External type instrument shall have external chamber/cage with 2" flanged end connections with ¾" flanged vent and drain connection provided with blind flange. Accuracy (inclusive of linearity, repeatability and hysteresis) shall be better than  $\pm 3$  mm, repeatability shall be better than  $\pm 3.0$  mm, Response time (i.e. 63.2% response) shall be better than 1 second.
- b) Ultrasonic type level instrument shall have ultrasonic probe which shall be selected to ensure that distance between the probe and the maximum level of interest is more than the blocking distance of the probe. Accuracy inclusive of linearity, repeatability and hysteresis shall be better that  $\pm 0.25\%$  of measuring range.
- c) Radio-frequency type level instruments shall have rod or rope type probe. Accuracy inclusive of repeatability, linearity and hysteresis shall be  $\pm 0.5\%$  of the level measurement range.

Generally all the above level instruments shall meet the following;

- i) Sensor/ Probe shall be of flanged construction with 2" size. In case of welded flanged connection design, the weld joint shall be of radiography quality. Probe shall be of rugged construction without any mechanical moving part and shall not be affected by abrasion because of fluid turbulence. The probe design shall ensure that the deposits, dust, noise, foam or turbulence in the fluid, shall not affect the performance of the offered level instruments.
- ii) Instrument electronics shall be shall be of microprocessor based capable of being configured locally, either using an integral keypad or through a hand held configurator and compatible with the associated level probe. It shall comprise of pre-amplifier, converter, transmitter, switching amplifier etc. as applicable for the specified application. Vendor shall ensure that the input/output signals and performance characteristics of individual item provided as a part of each special level instrument are compatible with each other. Instrument electronics shall be integral with the probe.



iii) Offered probe/ sensor shall also have compatible certification. Switching Amplifier unit shall have repeatability better than 1%.

### **3.1.3.5 Level Switch (wherever applicable)**

Level switches shall generally be external float type with flanged head. Internal float/ displacer operated switches shall be used for viscous and underground tanks.

- a) Level switches shall generally be external ball float type with flanged head. External displacer type level switches can be considered for lighter fluids where specific gravity is less than 0.5. Internal ball float/ displacer type (top or side mounted) level switches shall only be used if external ball float/displacer type is not possible, like in viscous services and in underground tanks/vessels. Mechanical stops shall be provided so as to prevent reset of contacts while the switch is still in alarm condition. Float/displacer material used shall be SS316 minimum. Repeatability shall be 2 mm or better.
- b) Multi float / displacer level switches shall be avoided in process service.
- c) Switch shall be sealed snap action micro type with contact rating suitable for the specific application. Level switches with Reed switch shall not be used.
- d) For external cage type level switches, the switching point shall be 70 millimeters below the centre line of top connection for both high as well as low level application.
- e) In case of tandem type level switch, high and low level actuation points shall be adjustable. All switches shall be provided with very low differential, unless otherwise stated. The Vendor shall indicate differential.

### **3.1.4 Flow Instruments**

General:- Flow meter shall be of in-line mounting design with flow direction clearly marked on the flow meter body to ensure correct installation.

Flow meter design shall ensure that the location and / or orientation of installation of flow meter in the line shall not affect the calibration, accuracy and performance of the meter.

#### **3.1.5.1. Variable area flow meter/Rotameter**

Variable area flow meters shall be as per ISA-RP 16.1, 16.2, 16.3, 16.4, 16.5 and 16.6 and shall be used for viscous or corrosive services or where rangeability in flow precludes the use of an orifice. In general, variable area flow meters shall be selected such that the meter end connections are same as the line size. Flow meter design shall be such that it eliminates the stagnant areas. Flow meter shall have float stops at the top and bottom, which shall be easily removable.

Differential Pressure Valve : Differential pressure regulator shall be used to maintain constant flow rate irrespective of variation in the inlet / outlet operative pressure as per the application indicated. Vendor shall select a proper differential pressure regulator depending upon the line pressure and the flow requirement. The material of differential pressure valve/constant differential valve and needle valve including the interconnection piping shall be same as flow meter tube material, as a minimum. Performance Requirements : Unless otherwise specified, the variable area flow meter shall meet the following performance specifications;

Flow meter Transmitter Accuracy : better than  $\pm 2\%$  of full scale

Repeatability : better than  $\pm 0.5\%$  of full scale

#### **3.1.5.2. Glass Tube Variable Area Flowmeters**

Glass tube variable area flow meters shall be used for low pressure utility services for local indication and where line size is 1-1/2" or less. Glass tube variable area flow meters shall not be used if outlet line is connected to a line or vessel containing hazardous or toxic fluid unless a check valve is installed at the downstream side of variable area flow meters. Glass tube flow meters shall have their metering tube made of toughened borosilicate glass and shall be thick walled. Borosilicate glass tubes shall be used keeping in view the



recommended safe working pressure for different meter sizes and operating temperatures as per clause 6.1 of ISA-RP16.1, 16.2 and 16.3.

All glass tube flow meters shall be adequately shielded with safety glass on the reading side and amply vented. The glass tube flow meters shall be considered in low flow applications up to and including ANSI 300# rating only. Metal tube / Glass Tube flow meter Accuracy : better than  $\pm 2\%$  of full scale Repeatability : better than  $\pm 0.5\%$  of full scale

### **3.1.5.3. Metal Tube Variable Area Flow meters :**

Metal tube variable area flow meters shall be used for all process fluids. The body rating of the meter shall at least be equal to the rating of the end connection. Metal tube meters shall have the motion of the float transmitted via a magnetic coupling for secondary functions like indication, transmission or alarm.

### **3.1.5.4. Magnetic type flow meters:**

Magnetic flow meter shall be used for electrically conductive slurry or corrosive services with minimum conductivity of 5 mho/cm and shall be installed with line size bypass, with block and clean out valves, at the lowest point in piping to ensure that meter run is always liquid filled. Flow meter shall be of in-line mounting design insertion type of magnetic flow meter shall not be offered.

Following velocity limits shall be considered for meter sizing.

- a) For slurries and viscous flow: 4 to 5 m/s.
- b) For all other services: 2 to 3 m/s.

Velocity beyond these limits shall not be considered for sizing.

Flow meter shall be provided with integral earthing reference electrode when installed in on-lined pipe and an earthing plate / ring when installed in lined pipe to achieve potential equalisation between sensor and liquid. Unless specifically indicated, earthing electrode shall not be acceptable in place of earthing ring. The electrodes including earthing ring shall be connected in the intrinsically safe circuit for flow meter handling electrically hazardous fluids. Magnetic field coils shall operate on an alternating supply voltage, as specified. Coil insulation should be class F suitable for high temperature as per IEC 60085/IS 1271. Electrodes shall have good corrosion resistance and shall be welded to meter body. Field replaceable electrode construction shall be offered only when process fluid is coating character. Accuracy inclusive of linearity, repeatability and hysteresis shall be better than  $\pm 0.5\%$  of flow rate and repeatability of the magnetic flow meter shall be better than  $\pm 0.1\%$  of flow rate.

### **3.1.5.5. Paddle Wheel type flow meters:**

#### **Flow Sensor**

- a) Type : Paddle Wheel, On-line.
- b) Installation fitting Type : Saddle / Strap on fitting depending on line size.
- c) Sensor Length : To suit the pipe line size
- d) Cable Length from sensor to : Min 5m transmitter

#### **Transmitter**

- a) Type : 2 wire type, with separate remote mounted display unit.
- b) Scale range, Cu.m./ Hr : As per process requirement.
- c) Mounting : Skid/Wall mounted type. Suitable mounting accessories to be offered.
- d) Protection : IP 55, weather proof.
- e) Power supply : 24 V DC +/- 10%
- f) Accuracy :  $\pm 1\%$  of full scale.
- g) Output Signal : 4-20mA DC



- a) Mounting bracket shall be supplied for Pipe / Rack mounting of the indicator.
- b) The upstream & downstream straight length requirements for the flow sensor shall be indicated in the offer.
- c) Calibration test to be done for Sensor & Indicator and T.C to be furnished.

### **3.1.6. ANALYSERS**

#### **General**

Vendor shall be responsible to supply all types of analysers required for the System.  
Vendor to note:

- a) Vendor's scope shall include supply of various analysers like TOC Analyser, Oil in Water Analyser, turbidity, Chlorine Dioxide, ORP, pH & Dissolved Oxygen Analysers etc. as applicable as per requirement of finally approved P&IDs & other process documents and as per specifications complete with sample system designed for the specific purpose. Vendor shall supply in-line Analysers with necessary transmitters mounted in the field. In-situ analysers shall be capable of withstanding line pressure and temperature conditions. Analysers shall be supplied as per the approved P&IDs with functional requirements as specified elsewhere. Where no specifications are available, Vendor shall detail out the same in line with international codes and practices, specifications provided with this document and last but not the least as per good engineering practices followed by analyser industry. In all such cases, Vendor in their own interest must get performance specification reviewed by Owner/Owner Representative before proceeding with further engineering & procurement.
- b) All analysers shall be micro-processor based in general and shall be capable of providing detail diagnostic alarms, messages to help maintenance personnel. These system alarms shall be connected to the PLC system in Central Control Room. The configurational data of the analyser including set range shall be stored in a non-volatile memory. Vendor shall provide smart transmitters, in general, for all the analysers. However in case SMART transmitters are not available for any particular type from the approved vendors, Vendor may supply Non-Smart type.
- c) The span of the analyser shall be adjustable from the analyser front without opening the analyser enclosure. In case separate device is required to make such a change, same shall be included.
- d) The material of construction selected by Vendor must be suitable for fluid being handled. Vendor must select SS316 as a minimum.
- e) All components of the analysers shall be certified suitable for the hazardous area classification.
- f) The design of sample system for all the above analysers shall ensure a clean representative and measurable sample for the selected analysers. System shall include sample probe, pressure reducing station, filters, regulators, relief valves, sample cooler etc as required. The design shall include a sample flow switch, which will provide alarm and inhibit analysis whenever a low flow is sensed. Filters shall always be provided in dual configuration. It shall be possible to replace the filter without upsetting the operation of the analyser. Vendor shall consider provision of fast loops and sample return to process as necessary to meet performance requirements. The sample return shall not be vented or routed to drain unless the return is a waste product.



- g) The analyser cabinet for the analysers shall be mounted in the field with canopy. A glass cover shall be provided for the panel front mounted items. The analyser cabinet shall be certified suitable for hazardous area classification. Further all the items / components including analyser electronics to be mounted in the analyser cabinet shall also be site environmental condition or otherwise Vendor shall provide industrial grade air conditioner of required rating in the cabinet to make all the components suitable for site environmental conditions.
- h) The configurational data of the analyser including set range shall be stored in a non-volatile memory such that this remains unchanged because of power fluctuations or power off condition. In case vendor standard instrument has battery backed RAM, vendor to ensure that battery drain alarm is provided as diagnostic maintenance message.
- i) Vendor shall be fully responsible for and shall arrange for analyser sub-vendor assistance for commissioning of the analyser system.
- j) All the analysers shall be supplied pre-assembled, pre-tubed and pre-wired condition complete with sample handling system. All the interconnecting wiring shall be colour coded/ numbered and terminal blocks shall be clearly identified.

### **3.1.5.1. CIO2 Analysers:**

Measurement Principle: Amperometric

Protection Class: IP65.

Overall accuracy:  $\pm$  max. 0.5 % of measured value  $\pm$ 4 digits.

Repeatability:- max. 0.2 % of measuring range

Output: two wire, 4-20 mA, isolated.

Temperature compensation: automatic, built-in.

Local indication: digital, LCD indicator.

Mounting: local on 2" pipe, mounting kit (bracket, clamp, nuts etc.) to be

Supplied or flat vertical surface such as wall ,panel,stand etc.

Sensor: flow through with flow powered cleaner Assembly body: PMMA, Mounting parts: PVC, stainless steel 1.4571 (AISI 316 Ti), EPDM.

Measuring electrolyte: buffer solution.

Pre-amplifier: built-in.

Power Supply: 110V AC  $\pm$  10% 50Hz  $\pm$  1%

Calibration: semi-automatic using pre-configured buffer tables.

Span and Zero adjustment required.

CIO2 analyser shall be installed in such a manner that wetted parts are protected from oily sludge & other impurities present in the water. Automatic timer actuated cleaning / purging system should be provided to enhance the life of electrode.

### **3.1.5.2 Gas Detector-Toxic gas detectors (Chlorine and others)**

- a. All gas detectors shall be suitable for outdoor installation certified for use in electrically hazardous area. The detectors shall be weather proof to IP65 in accordance with IEC-60529, as a minimum and certified flameproof (EExd) or certified intrinsically safe (EEx i) for the specified area classification as specified in purchaser's data sheet.
- b. Unless otherwise specified, all gas detectors shall be provided with dust guard and splashguard.
- c. All gas detectors shall be provided with Terminal box for terminating incoming cabling. Flying leads shall not be acceptable. The cable entry in the terminal box shall be 3/4" NPTF.
- d. All gas detectors shall be smart type with HART protocol.



- e. All detectors shall be provided with local digital display, which shall provide currently detected gas concentration.
- f. Mounting accessories required for the installation of gas detectors shall be provided.
- g. The toxic gas detectors for Chlorine and other Toxic gases shall be of electrochemical cell type.
- h. The Electrochemical cell requiring replenishment of electrolyte shall not be offered.
- i. The field life of Electrochemical type of sensor shall be 2 years as a minimum. The cell shall be able to be replaced in-situ.
- j. Toxic gas detector and its terminal box shall preferably have metallic body. Alternately vendor's standard material of construction shall also be acceptable.
- k. Range: Unless otherwise specified, the range of toxic gas detectors shall be as follows:
  - Chlorine detectors: 0-10ppm
  - Other detectors As per purchaser's data sheet
- l. Performance Requirements:
  - The offered toxic gas detectors shall meet the following performance requirements:
    - Repeatability:  $\pm 2$  % of full scale
    - Response time T90: Less than 60 seconds with splashguard and dust guard.

### **3.1.5.3 Density indicator transmitter**

#### **a) General Information**

- 1 Type Density Indicator
- 2 Service To check density of 30% HCl acid in storage tank

#### **b) Instrument Characteristics**

- 4 Sensor Type process compatible
- 5 Accuracy <3%
- 6 Drift over time <5%/year
- 8 Measuring range 700-1400 kg/m<sup>3</sup>
- 9 Fluid handled 30% HCL acid in storage tank
- 10 Operating Pressure <2bar
- 11 Response Time < 120 secs
- 12 Power Supply 2 wire loop powered 24vDC/4 Wire 110V AC  $\pm 10$ %  
50Hz  $\pm 1$ %
- 13 Analog Output 4-20 mA
- 14 Display LCD display (4 Digits) with backlight
- 15 Material of Body Aluminium LM25
- 16 Mounting details local on 2" pipe, mounting kit (bracket, clamp, nuts etc.)  
to be supplied or flat vertical surface such as wall ,panel,stand or on top of tank.etc
- 17 IP Rating IP 66

#### **c) Test to be carried out**

- 22 Calibration check Single Point Calibration
- 23 Power ON, Simulation Check Manufacturer Test Certificate

#### **d) Testing Standard**

- 24 Design Standard Manufacturer Standard
- 25 Testing Standard Manufacturer Standard

### **3.1.6 MISCELLANEOUS REQUIREMENTS**

#### **Proven Track Record (PTR)**



**SPECIFICATION FOR ELECTRICAL  
CONTROL & INSTRUMENTATION**

**SPEC. NO.: ROS 4085**

**REV. NO: 00**

The instrumentation selected for the units shall be rugged in design and must be well proven in the hydrocarbon industry. Prototype design or equipment of experimental nature or design undergoing testing etc. shall not be selected and supplied. Following criteria must be applied before selecting a particular instrument item:

a) For Instrument Items (Other than Systems) The instruments as being offered / supplied should have been operating satisfactorily in hydrocarbon industry like Refinery, Petrochemical and Gas Processing Plant under similar process conditions for at least 4000 hrs.

b) For System Oriented Item

i) The system (with all its sub-systems) as being offered / supplied should have been installed and operating satisfactorily in hydrocarbon industry like Refinery, Petrochemical or Gas Processing Plant for at least 4000 hrs (as collaborated by user certificate).

ii) The system should be supplied, engineered, integrated tested etc. from a factory from where the system / sub-systems as offered / supplied have already been supplied, engineered, integrated tested etc. and meet the criteria b(i) above.

iii) All the activities including engineering should be carried out by the agency, which have carried out the similar activity in the past and meets the criteria b(i) above.

iv) The system should be supplied by the manufacturer in the fully engineered condition or should be supplied by the manufacturers representative / subsidiary who have proper infrastructural facilities and meets the criteria b(i) above.

v) In any case, the manufacturer whose system is being offered / supplied should have a local representation / subsidiary which has the proper infrastructural facilities like engineering, installation, maintenance, testing, spare part support, system fault diagnosis and other related logistic support. Systems, which don't have the local base, should be avoided.

c) The installation & hook up standards selected in cryogenic services shall be proven for application in similar services as per above provenness requirement.

### **3.1.6. Pneumatic Actuator**

a) Valve actuator shall be pneumatic spring opposed diaphragm type, in general. If required, Piston and cylinder type actuators may be used .

b) Actuator shall be designed to move the valve to the failure position specified. In fail-locked" case, fail-lock relays shall be provided.

c) Actuator casing shall be made of pressed steel or anodised aluminium. Non-metallic actuator casings shall not be offered.

d) Springs shall be corrosion-resistant and shall be cadmium or nickel-plated. Alternately valve manufacturer standard coating shall also be acceptable. These shall be of the enclosed type. The compression of the springs shall be adjustable.

e) In general, an actuator operating range of 0.2-to 1.0 kg/cm<sup>2</sup>g is preferred. However when valve standard actuator model is not able to meet the specified shutoff pressure, higher actuator operating range may be offered.

f) Whenever piston and cylinder actuator is considered, single acting spring return type shall be used.

g) Whenever double acting springless type of actuator is unavoidable, all accessories like pilot valves, booster relays, non-return valve, pressure gauge, volume tank etc. shall be provided to ensure desired action on air failure. The volume tank shall be sized considering full stroking of the valve for two complete cycles (three complete cycles for on-off valves). The volume tank shall be of carbon steel construction and sized as per ASME Section VIII with design pressure of 10kg/cm<sup>2</sup> g as a minimum. All accessories and tubing etc shall be of SS316.



**SPECIFICATION FOR ELECTRICAL  
CONTROL & INSTRUMENTATION**

**SPEC. NO.: ROS 4085**

**REV. NO: 00**

- h) The actuator casings and diaphragms shall be designed for minimum twice the maximum pneumatic operating pressure of the control valve.
- i) The control valve actuator colouring scheme shall be as follows:-  
Direct Acting (Open on Air failure) valves:- Green.  
Reverse Acting (Close on Air failure) valves:- Red
- j) Valve stem position indicator shall be provided for every control valve. The position indicator scale shall be marked from 0 to 100% (in steps of 10% for control valves).
- k) Actuator shall be sized to meet the following as a minimum:.
- i) For control valves with leakage class IV and below, the actuator shall be sized considering actuator thrust more than 1.3 times the total force induced by shut-off conditions specified in the data sheet and the force required to overcome packing friction. The above factor shall be considered as 1.5 in case the control valve is operating between 80% to 90% or 10% to 20% in any of the specified conditions.
- ii) For control valves with leakage class V and above, the actuator shall be sized considering actual thrust more than 1.7 times the total force induced by specified shut-off conditions in the purchaser's data sheet and the force required to overcome packing friction.
- iii) For on-off valves the actuator shall be sized to develop sufficient thrust to properly seat the on-off valve at the lowest specified air pressure.
- iv) Actuator shall be sized based on instrument air supply pressure of 4.5 kg/cm.sq.g. While sizing the actuator Vendor shall consider actuator thrust equal to two times (2) the total force induced by shut off condition and the force required to overcome packing friction.
- l) Control valve accessories such as positioner, air filter regulator and solenoid valve shall be properly mounted on the actuator and shall be fully tubed.
- m) The jacketed valves shall have steam inlet/outlet connections as flanged.
- n) Valve end connections shall be one size higher than the normal valve connections for jacketed valve. For steam jacketed on-off valves, the body and port size shall be one size lower than the on-off valve end connections.
- o) Valve pneumatic positioners wherever used shall be side mounted force balance pneumatic type. Smart digital type or field bus type positioner shall be used wherever specified in job specification For details of Smart and field bus type positioner refer cl.
- p) Separate air filter regulator shall be used for each valve positioner.
- q) Positioners shall be direct acting, with an adjustable gain unless otherwise specified.
- r) The pneumatic positioner shall be provided with an integral by-pass switch whenever the operating range of the actuator is the same as that of the control signal.
- s) Every positioner shall have two pressure gauges mounted on it, one each for air supply and for positioner output to actuator. In addition pneumatic positioner shall have third pressure gauge for control signal.
- t) Pneumatic connections shall be 1/4" NPT (F) and cable entry shall be 1/2" NPTF to ANSI/ASME B1.20.1. If connection for cable entry is different than that specified, suitable adapters shall be provided.
- u) Positioners shall be side-mounted on the control valve and shall have corrosion resistant linkages and rugged brackets, unless remote mounted positioner is offered when specified.
- v) Separate I/P converter shall be provided wherever pneumatic positioner is specified Electro-pneumatic converter shall be of electronic feedback type and shall be yoke mounted.
- w) Overall accuracy of the electro-pneumatic converter shall be better than  $\pm 0.3\%$ .
- x) Unless otherwise mentioned, it shall be intrinsically safe.
- y) Pneumatic connections shall be 1/4" NPT (F) to ANSI B 2.1. The electrical connections shall be 1/2" NPT (F). If they are different, suitable adapters shall be provided.
- z) Each positioner shall be provided with air filter regulator complete with an integral output gauge.
- a1) The air filter regulator mesh size shall be suitable for I/P converter.
- b1) Filter material shall be sintered bronze/Ceramic/SS and shall be provided with manual drain and 2" nominal size pressure gauge
- c1) Filter size shall be max. 5 microns.



**SPECIFICATION FOR ELECTRICAL  
CONTROL & INSTRUMENTATION**

**SPEC. NO.: ROS 4085**

**REV. NO: 00**

- d1) The body of the filter shall be anodised aluminium. The same can be SS also, if mentioned in job specifications.
- e1) Whenever limit switches are specified as inductive proximity type, these shall meet NAMUR (DIN-19234) requirements.
- f1) Separate limit switches (potential free contacts) shall be provided for open and close position, where required.
- g1) Solenoid valves, wherever used, shall be universal type and shall be continuous rated type with class F coil insulation as per IEC 60085/IS 1271. These shall be of brass body with SS316 trim, as a minimum.
- h1) Self actuating regulators for flow, pressure and temperature shall be used as indicated in P&ID.
- i1) Whenever fire safe requirement is specified for a shutdown valve, the valve body as well as the actuator shall meet the testing requirements as per API 607 latest revision. In addition to above, air volume tank shall also be provided for storage of air volume with minimum two full strokes of valves. All valve accessories like solenoid valve, limit switches and volume tank etc shall also be enclosed in a certified fireproof enclosure. The cable used for actuation of the valve shall also be fire resistant (Fire Survival to IEC 60331).
- j1) All valves in cryogenic service (i.e. the valves installed in piping classes used for temperature below  $-29$  Deg C) shall be designed and tested as per BS-6364.
- k1) Control valves/shutdown valves requiring certain specified operating timings, shall be tested before despatch for the specified operational time verification. Hook-up drawings alongwith the timing calculation shall be submitted by Vendor for review.
- l1) The body shall be in general painted as follows: Carbon steel body- Light grey, Alloy steel- Canary yellow, SS – Natural, Above  $150^{\circ}\text{C}$ - Aluminium paint (white colour). Items like silencers, diffuser plate assemblies etc., shall be painted as per respective control valve body requirements.
- m1) The actuator shall be painted as follows: Direct action (open on air failure) valves- green, Reverse acting (close on air failure) valve- yellow, Shutdown valves – red, Items like air volume tanks etc., provided as an accessory along with the actuators, shall be painted as per corresponding actuator.
- n1) The limit switch box and solenoid valve of POV shall be supplied with cable glands suitable for 2pair 1.5 sq.mm instrument cable.

### **3.2 Specification for Instrument Cables & Instrument Power cables**

Multi cables between the field instruments and field junction box shall be as per following philosophy:

- a) Signals (4-20 mA or switch contact): 2pair individually and over all shielded (screened) and armoured, twisted.
- b) Instrument Power Supply(110V AC  $\pm 10\%$  50Hz  $\pm 1\%$  UPS supply): 3C 2.5 sq.mm stranded copper, armoured

All power supply cables shall be as per IS-1554 Part I and shall have copper/aluminium conductors depending on conductor size. Minimum conductor size shall be 2.5 mm<sup>2</sup> of copper conductor. For higher sizes, aluminium conductor can be considered. All these cables shall be PVC insulated and armoured. Any other special cable required for instruments shall also be provided as per requirements. Contractor shall ensure that these cables are armoured type and shall meet all other requirements mentioned in this specification. In general, 80% of pairs of multicables shall be used i.e connected to instruments. Remaining pairs shall remain unused however same shall be suitably terminated at junction boxes/ Local control panels/ Marshalling racks etc.

#### **3.2.1 General Specification**

The cables and accessories shall also conform to the provisions of CEA Regulations and other statutory regulations, as applicable.



In case of any conflict between requirements specified in various applicable documents for the project, the most stringent one shall prevail. However, Owner's decision in this regard will be final and binding.

All cables shall have PVC insulated primary insulation of 85 C PVC as per IS-5831 Type C. Thickness of primary insulation shall be 0.5 mm as a minimum. For PE insulated cables, primary insulation shall be of 70 C Polyethylene. Inner and outer jacket (sheath) shall be made of extruded flame retardant 90 C PVC to IS-5831 Type ST-2 and meeting flame retardant requirements for bunched cables as per IS 10810 (Part 62) category AF or IEC 60332 category A. Minimum Oxygen index of PVC shall be 30% at 27 C  $\pm$  2 C, temperature index shall be over 250 C, a rip cord shall be provided for inner sheath, Outer sheath shall be suitable for protecting the cable against rodent and termite attack.

All cables shall be fire retardant as per standard IEC 60332-3 Part 3 Cat.A.

The insulation grade shall be 600 V/1100 V as a minimum and shall meet insulation resistance, voltage and spark test requirements as per BS-5308 Part-2.

All cables shall be armoured. Armour over inner jacket shall be of galvanised steel wire/flat as per IS-1554 part I. Requirement and methods of tests for armour material and uniformity of galvanisation shall be as per IS 3975 and IS 10810 (Part 40) respectively.

All the cores of single pair or multipair shall be twisted and numbers of twist shall not be less than 10 per meter.

The thickness of the sheath shall be as per IS 1554 part 1.

Tolerance in overall diameter of cable shall be within  $\pm$  2 mm over offered value.

Overall twist of all pair/triads shall be as per vendor's standard.

For signal and control cables, inner sheath colour shall be black.

Vendor shall ensure a minimum of 20% of quantity of each type of cables provided as spare including any special cable. And in each multipair cables 20% pairs shall be kept as spare.

Running length of the cable shall be printed at least at every 1-meter interval. For multipair/multitriad cables, a pair identification shall be provided with numbers at interval of not more than 250mm as per vendor's standard. The embossing /engraving shall be legible and indelible.

### **3.2.2 Instrument Signal Cables**

The Type-I single pair/triad cables shall be 1.5mm<sup>2</sup> conductor size made of annealed electrolytic copper conductor of 7 strands with each strand of 0.53 mm diameter.

Type-II Multipair/ Multi-triad cables with individual pair/ triad shield and overall shield with 1.5mm<sup>2</sup> conductor size shall have 7 strands of annealed electrolytic grade copper conductor with each strand of 0.53 mm diameter.

Type-III (Multi-pair / Multi-triad cable with only overall shield) cable shall be same as type-II cable, except that the individual pair/ triad shall not have shielding.

Type-IV Multi-pair /Multi-triad cable (with individual pair shield and overall shield) with 1.5 mm<sup>2</sup> conductor shall have 7 strand with each strand of 0.53 mm diameter.

Type-V Multi-pair / Multi-triad cable (with overall shield only) shall be same as type IV except that the individual pair/triad shall not have the shielding.

Each pair/triad shall be shielded. Shield shall be aluminium backed mylar/polyester tape bonded together with metallic side down helically applied with either side having 25% overlap on either side and 100% coverage. Minimum shield thickness shall be 0.05 mm in case of single pair/ triad and 0.075 mm in case of multipair/ triad cable.

Drain wire shall be provided for individual pair and overall shield which shall be 0.5 mm<sup>2</sup> multi stranded bare tinned annealed copper conductor. The drain wire shall be in continuous contact with aluminium side of the shield.

Maximum DC resistance of the conductor of the completed cable shall not exceed the following:-

- a) 12.3  $\Omega$ /km at 200C for cables with 1.5 mm<sup>2</sup> conductor.
- b) 39.7  $\Omega$ /km at 200C for cables with 0.5 mm<sup>2</sup> conductor.



The mutual capacitance of the pair/ triad or adjacent cores shall not exceed 250 pF/m at a frequency of 1 kHz and between the pairs/ triads for PE Insulated cables shall not exceed 100 pF / metre at a frequency of 1 KHz. The capacitance between any core and screen shall not exceed 400 pF/ m at a frequency of 1 kHz.

L/R ratio of adjacent cores shall not exceed 40  $\mu\text{H} / \Omega$  for cables with 1.5 mm<sup>2</sup> conductor and 25  $\mu\text{H} / \Omega$  for cables with 0.5 mm<sup>2</sup> conductor.

The drain wire resistance including shield shall not exceed 30  $\Omega/\text{km}$ . Electrostatic noise rejection ratio shall be over 76 dB.

Contractor shall ensure a minimum of 20% of quantity of each type of cables provided as spare including any special cable. And in each multipair cables 20% pairs shall be kept as spare.

Running length of the cable shall be printed at least at every 1-meter interval. For multipair/multitriad cables, a pair identification shall be provided with numbers at interval of not more than 250mm as per vendor's standard. The embossing /engraving shall be legible and indelible.

### **3.2.3 ELECTRICAL FIELD WIRING**

a) Instrument electronic signal (non FF) & alarm cables, single pair as well as multipair shall be 1.5 mm<sup>2</sup> twisted in pair individually and overall shielded with aluminium Mylar tape with drain wire and armoured.

b) Control wiring for actuating devices and solenoid valves of the interlock and shutdown system shall generally be 1.5 mm<sup>2</sup> armoured cable.

c) Multicore extension cables for Thermocouples, wherever applicable, shall be 20 AWG single conductor twisted pairs, armoured, individual pair and overall aluminium mylar shielded with over all drain wire. Single pair extension cables shall be armoured cable with 16 AWG single conductor wire.

d) Power supply cables to field instruments shall be minimum 2.5 mm<sup>2</sup> armoured.

e) All cable glands shall be of nickel-plated brass and they shall be of double compression type suitable for armoured cables.

f) Generally PVC insulated cables shall be used.

g) For longer distances conductor sizes shall be selected based on voltage drop.

### **3.2.4 INSPECTION, TESTING AND ACCEPTANCE**

The cables shall be tested and inspected at the manufacturer's works. Manufacturer shall furnish all necessary information concerning the raw material supply to EIL/ Owner's inspectors. The inspector shall have free access to the manufacturer's works for the purpose of inspecting the process of manufacture in all its stages and he will have the power to reject any material, which appears to him to be of unsuitable description or of unsatisfactory quality. For HV cables, the vendor shall give at least 2 weeks advance notice to the purchaser, regarding the date of testing to enable him or his representative to witness the tests.

After completion of manufacture of cables and prior to despatch, the cables shall be subjected to type, routine, acceptance and special tests as detailed below. The test reports for all cables shall be got approved from the Engineer before despatch of the cables. All routine tests, acceptance tests, type tests and additional type tests for improved fire performance shall be carried out as listed in IS: 1554 (Part-1) and IS: 7098 (Part-2) on PVC and XLPE insulated cables respectively.

The test requirements for PVC insulation and sheath of cables shall be as per latest revision of IS: 5831. Test for Resistance to Ultra Violet Radiation: This test shall be carried out as per DIN 53387 or ASTM-G-154 on outer sheath. The retention value of tensile strength and ultimate elongation after the test shall be minimum 60 % of tensile strength and ultimate elongation before the test. Test certificates with respect to this test (not older than one year) from recognised testing laboratory to be furnished for review by EIL before despatch clearance of cables. In case test certificates are not available, test is to be conducted by vendor at his own cost in any recognised test laboratory or in house testing laboratory, before despatch clearance



**SPECIFICATION FOR ELECTRICAL  
CONTROL & INSTRUMENTATION**

**SPEC. NO.: ROS 4085**

**REV. NO: 00**

of cables. Sampling for this test is to be done randomly once for each order, provided outer sheath remains same. Acceptance tests as per IS-1554 (Part-1) and IS-7098 (Part-2) and the following special tests to be performed on the cables as per sampling plan for all cables. However these tests are required to be witnessed by EIL/ Owner for HV cables. Accelerated water absorption test for insulation as per NEMA-WC-70. (For PVC insulated cables) and as per NEMA-WC-53 (for XLPE/ EPR insulated cables). Test certificates with respect to this test (not older than one year) from recognised testing laboratory to be furnished for review by EIL before despatch clearance of cables. In case test certificates are not available, test is to be conducted by vendor at his own cost in any recognized test laboratory or in house testing laboratory, before despatch clearance of cables. Sampling for this test is to be done randomly once for each order, provided type of insulation remains same.

**Dielectric Retention Test:** The dielectric strength of the cable insulation tested in accordance with NEMA-WC-70 at  $75 \pm 1^\circ \text{C}$  shall not be less than 50 % of the original dielectric strength. (For PVC insulated cables). Test certificates with respect to this test (not older than one year) from recognised testing laboratory to be furnished for review by EIL before despatch clearance of cables. In case test certificates are not available, test is to be conducted by vendor at his own cost in any recognized test laboratory or in house testing laboratory, before despatch clearance of cables. Sampling for this test is to be done randomly and once for each order.

**Oxygen Index Test:** The test shall be carried out as per IS-10810 (Part 58). Sampling to be done for every offered lot/size as per sampling plan.

**Flammability Test:** The test shall be carried out on finished cable as per IS-10810 (Part 61 & 62). Sampling for these tests is to be done randomly once for each order, provided outer sheath remains same. The acceptance criteria for tests conducted shall be as under:

Part-61-The cable meets the requirement if there is no visible damage on the test specimen within 300 mm from its upper end

Part-62-The maximum extent of the charred portion measured on the test sample should not have reached a height exceeding 2.5 m above the bottom edge of the burner at the front of the ladder.

Test for rodent and termite repulsion property shall be done by analysing the property by chemical method.

Routine and acceptance tests as listed in relevant Indian standard and equipment specifications shall be conducted.

Type test if listed in Inspection and Test Plans and in the relevant data sheet shall be conducted. Type test, if specified, shall be conducted only on one of equipment of each type and rating.

These tests shall be carried out by the Contractor/ vendor/ sub-vendor and shall be witnessed by Owner/ PMC or an agency authorized by Owner/ PMC.

The cable shall be inspected and tested based on the following documents.

1. Approved Quality Plan
2. BHEL Technical Specification
3. BHEL Purchase order
4. BHEL approved supplier's data sheet

### **3.2.5 PACKING AND DESPATCH**

Cables shall be despatched in non-returnable wooden or steel drums of suitable barrel diameter, securely battened, with the take-off end fully protected against mechanical damage. The wood used for construction of the drum shall be properly seasoned, sound and free from defects. Wood preservatives shall be applied to the entire drum. Ferrous parts used shall be treated with a suitable rust preventive finish or coating to avoid rusting during transit or storage. On the flange of the drum, necessary information such as project title, manufacturer's



name, type, size, voltage grade of cable, length of cable in metres, drum no., cable code, BIS certification mark, gross weight etc. shall be printed. An arrow shall be printed on the drum with suitable instructions to show the direction of rotation of the drum.

### 3.3 Specification for Junction Boxes

The junction box shall be suitable for the type of signal and type of multicore cables used as indicated below. Unless otherwise specified, Vendor must use the following type of junction boxes:

Separate junction boxes shall be used for the following type of signals:

- Non Intrinsically Safe Analog Inputs/Outputs (4-20 mA)
- Non Intrinsically Safe contact Inputs.
- Non Intrinsically Safe contact Outputs.
- Electrical Junction Boxes for Analyser power supply ie 110 V AC

#### 3.3.1 Junction Boxes and Wiring/ Termination blocks for Analog Outputs, Analog Inputs, Digital Inputs & Digital outputs.

- a) Junction boxes shall be either Weather proof type or Weather proof and flameproof type. No other type of junction boxes shall be offered / provided unless specifically required.
- b) Unless otherwise specified, the enclosure shall conform to the following standards:  
Weatherproof housing : IP 55 to IEC-60529/IS-13947
- c) Junction boxes with top entries shall not be offered. The size of cable entries shall be as per the cable sizes.
- d) Each junction box shall have spare entries as follows:
  - i) Minimum of 2 Nos. for 6P/12C JB
  - ii) 4 numbers for 12P/24C JB.

#### 3.3.2 Electrical Junction Boxes for Analyser power supply

- i) The material of construction of electrical junction boxes shall be die-cast aluminium of minimum 5 mm thick (LM-6 alloy).
- ii) Weather proof junction box shall have hinged type door with neoprene gasket, which shall be fixed to the box by plated countersunk screws.
- iii) Power junction boxes (junction boxes for power supply cable / distribution) shall have either the warning cast or shall have warning plate with following marking and shall be suitable for incoming armoured power cable up to 150 sq.mm conductor size: "Isolate power supply elsewhere before opening".
- iv) Terminals shall be spring loaded, vibration proof, clip-on type, mounted on nickel plated steel rails complete with end cover and clamps for each row.
- v) All terminals used in signal, alarm and control junction boxes shall be suitable for accepting minimum 2.5sq.mm copper conductor, in general.
- vi) Terminal used in power junction boxes / power supply distribution box shall be suitable for accepting conductor size of 4 Sq. mm to upto 120 sq. mm. Exact requirement shall be specified in job specification. Higher size of terminals shall be provided when indicated. Bus bar terminals shall be provided for conductor size of 50 sq. mm and above. Suitable size of lugs shall be provided to suit conductor size.
- vii) Each junction shall have minimum of 30% spare terminal of those actually required to be utilised. Number of terminals for various types of junction boxes shall be as follows;
  - 24 Nos. for 6 pair junction box.
  - 48 Nos. for 12 pair junction box
- viii) Terminals shall be identified as per the type of input signal e.g all terminals for intrinsically safe inputs shall be blue while others shall be grey in colour.
- ix) Junction boxes shall be provided with external earthing lugs.
- x) Sizing shall be done with due consideration for accessibility and maintenance in accordance with the following guidelines;



## SPECIFICATION FOR ELECTRICAL CONTROL & INSTRUMENTATION

SPEC. NO.: ROS 4085

REV. NO: 00

- 50 to 60 mm gap between terminals and sides of box parallel to terminal strip for upto 50 terminals and additional 25 mm for each additional 25 terminals.
- 100 to 120 mm between two terminal strips for upto 50 terminals and additional 25 mm for each additional 25 terminals.
- Bottom/top of terminal shall not be less than 100 mm from bottom / top of the junction box. Earthing bolts & nuts with lug shall be provided at opposite points on outside of the junction box with earth symbol.

### 3.3.3 Painting of Junction Boxes

- i) Surface shall be prepared for painting. It shall be smooth and devoid of rust and scale.
- ii) Two coats of lead-free base primer and two final coats of lead free epoxy based paint shall be applied both for interior and exterior surfaces.
- iii) All intrinsically safe junction boxes shall be Light blue and all others shall be of Light grey colour.
- iv) No painting is required for SS Junction Boxes.

### 3.3.4 Packing of Junction Boxes

Each JB shall be fully wrapped in a polythene cover to avoid water entry and then packed separately in cardboard box. Finally all such boxes shall be packed in a wooden crate.

### 3.3.5 Drawing of Junction Boxes

JB Manufacturing drawings such as General Arrangement, Mounting Arrangement, Terminal Block Details in AUTO CAD/PDF shall be submitted for approval by BHEL, (prior to start of manufacturing) within 10 days from the date of purchase order.

The junction boxes shall have cable entries suitable for the multi and single cables used. 20% additional cable entries must be provided. Unused entries shall be plugged. The junction boxes shall have terminals suitable for the cable wire size and shall preferably be of Phoenix or equivalent make.

The multi cable entry for 6 pair Junction Box (JB) shall be 1" NPTF and for 12 pair/ 8 triad junction box, it shall be 1 1/2" NPTF. Each junction box shall be provided with 2 multicable entries with one plugged with weatherproof, flameproof plug as required.

Multicable entries shall be from the bottom whereas 1 pair/triad from the side.

One junction box shall be connected to one multicable only. The other cable entry shall be plugged. The junction boxes in the field as well as local panels shall be provided with sufficient number of terminals to terminate all the pairs of multi-cable (including spare pairs) and shields of individual pairs as applicable.

## 3.4 SPECIFICATION FOR SOLENOID VALVE ENCLOSURE BOX (SVEB)

1.0 The solenoid valves shall be provided suitably as per the process requirement with corresponding SVEBs. The bidder shall locate the required no. of solenoid valves inside the enclosure box and do the tubing and wiring. The solenoid valve coil wires shall be terminated in a terminal block located inside the enclosure box. The inlet ports of the solenoid valves shall be connected to a common inlet manifold to which the air supply will be connected at site using a Air Filter Regulator (AFR). The outlet / vent connections of the solenoid valve shall also be connected to respective manifolds in each SVEB using SS 316 compression type tube fittings. The external tubing & wiring connections from the SVEB to the respective Pneumatic Operated Valve(POV) shall be taken care of by Bidder at site.



## 2.0 CONSTRUCTION:

The Solenoid Valve Enclosure Box (SVEB) shall be made from Cold rolled Sheet Steel Min 3 mm. The doors shall be hinged type. The enclosure shall be suitable for IP 55. Single piece Neoprene gasket of suitable thickness shall be provided on all mating surfaces to ensure watertight seal. Enclosure box shall have 4 fixing lugs & shall be suitable for wall mounting or angle iron frame mounting.

## SOLENOID VALVE:

- a) Quantity : 01 No. for each POV actuator.
- b) Type : Universal type single coil solenoid valve suitable for the pneumatic actuator.
- c) Body : Brass
- d) Plunger/trim : SS316
- e) Pressure range : 5 to 8 Kg/sq. cm
- f) Duty : Continuous
- g) Coil Voltage : 110 V AC $\pm$  10% 50Hz  $\pm$  1%
- h) Air Connection : 1/4" NPT(F)
- i) Protection : Weather proof IP65.
- j) Class of insulation: " F "
- k) Manual override for solenoid valve : Required.
- l) Shut off class : Class IV
- m) Make : As per vendor list enclosed with the enquiry.
- n) Low power type Solenoid Valves shall be considered.

## 3.0 Painting:

- a) Exterior : Epoxy based paint. Light grey (Shade : 631) as per IS-5. Paint thickness 100 microns. Finish – Semi Glossy
- b) Interior : Epoxy based white paint. Paint thickness 50 microns. Finish – Glossy

C) The following items are to be located in each SOV enclosure box and the box shall be sized to accommodate the same.

- a) Solenoid valves – Quantity as required POVs for a skid.
- b) Terminal Block (required No. of ways ) ,
- c) Cable Entry ; Bottom only
- d) Double compression cable gland suitable for 8 pair x 1.5 sq. mm PVC Armoured cable – As required
- e) Air Filter Regulator for each

Necessary SS316 tubing and compression fittings are to be supplied and mounted inside the enclosure Box for connection of the SOVs located inside.

The solenoid valve coils are to be wired to the terminal block by using 650V grade PVC insulated, 2.5 sq. mm stranded Copper flexible wire.

One No. ATC crimp type lug shall be provided on both sides of each TB.

Earthing bolts & nuts with lug shall be provided at opposite points on outside of the junction box with earth symbol.

Name plate with suitable inscription shall be provided for each box. The inscription details will be informed after ordering.



**SPECIFICATION FOR ELECTRICAL  
CONTROL & INSTRUMENTATION**

**SPEC. NO.: ROS 4085**

**REV. NO: 00**

Incoming line size & common header : ½” SS316 Tube  
Outgoing line size (To POVs) : ¼” OD SS316 Tube  
Exhaust line size & Common header : ½” SS316 Tube

#### 4 PACKING

Each SVEB shall be fully wrapped in a polythene cover to avoid water entry and then packed separately in cardboard box. Finally all such boxes shall be packed in a wooden crate.

#### 5 DRAWING

SVEB Manufacturing drawings such as General Arrangement, Mounting Arrangement, Terminal Block Details in AUTO CAD/PDF shall be submitted for approval by BHEL, (prior to start of manufacture) within 10 days from the date of purchase order.

### 3.5 Specification for Cable Trays, cable glands, Fittings

#### 3.5.1 Specification for Cable Trays

- a) All cables on the main pipe rack shall be laid in cable duct fabricated out of GI sheets.
- b) All branch cables shall be run on cable trays. The Perforated trays, Ladder trays and Angle trays shall be of Mild Steel hot dip galvanised. The Perforated trays shall be of 2.5 mm thickness.
- c) Cable tray laying to take care of the necessary clearances for fire proofing of structures.
- d) All branch cables/tubes shall run on cable trays. The cable trays shall be made out of Galvanised mild steel sheets of 2.5 mm thickness unless specified otherwise. Ladder trays shall be of mild structural steel and shall be hot dip galvanised. 50 mm x 50 mm angle shall be used as a minimum. The width shall be so selected that 50% of tray space is available for future use.
- e) Suitable cable clamps shall be provided for binding the cables/tubes at every 500 mm. Continuous channel for support of overhead duct shall be provided and shall be suitable for load considering 100% filling of duct by cables. For cable trays supports shall be provided at a minimum interval of 1.5m.

#### 3.5.2 Specification for Cable Glands

- a) Vendor shall provide all cable glands required for glanding the above mentioned cables both at field instrument and local control panel side, junction boxes side and at control room side.
- b) All cables glands shall be of nickel-plated brass and they shall be double compression type suitable for armoured cables.
- c) Flame proof glands wherever required shall be provided with Exd certification.
- d) Vendor shall provide a minimum of 20% of cable glands as spare.
- e) All cable glands shall be weather proof to IP-55.
- f) Cable glands shall be NPT for all field items and junction boxes where as ET thread with check nuts for control room end.
- g) Cable glands shall be provided to suit the cable dimensions along with tolerances. Various components like rubber ring, metallic ring, metallic cone and the outer / inner nuts etc. shall be capable of adjusting to the tolerances of cable dimensions.

#### 3.5.3 Specification for Instrument Valves, fittings and Manifolds

- a) Vendor shall provide instrument valves (miniature type) and valve manifolds wherever required.
- b) Vendor should refer hook up drawing (EIL) as ENCLOSED.
- c) For all valves and manifolds with body material of carbon steel/stainless steel, the valve trim material shall be SS316, as a minimum.



**SPECIFICATION FOR ELECTRICAL  
CONTROL & INSTRUMENTATION**

**SPEC. NO.: ROS 4085**

**REV. NO: 00**

- d) For any other body material, trim material should be same as body material as a minimum. Superior trim material shall be selected as required by process conditions. Packing material in general shall be of PTFE. The o-ring materials wherever used shall also be of PTFE.
- i. Instrument Valves (Miniature) shall be of globe pattern needle valves forged/ bar stock with inside screwed bonnet, with back-seated blow out proof system.
  - ii. Instrument Air Isolation Valves (Miniature) shall be full-bore ball type with forged body.
  - iii. Instrument Air Needle Valves (Miniature) shall be globe pattern-needle valves forged/ bar stock with inside screwed bonnet.
  - iv. For all these valves types, Body material shall be SS316.
  - v. End connection shall be ½”NPTF to ANSI B 1.20.1 for Instrument Valves (Miniature) and Instrument Air Isolation Valves (Miniature) and ¼” NPTF to ANSI B1.20.1 for Instrument Air Needle Valves (Miniature).
  - vi. For Instrument Valves (Miniature) and Instrument Air Needle Valves (Miniature), flow direction shall be marked on the body.

e) Vendor shall ensure that Qualification tests (hydrostatic proof and burst tests) as per MSS SP-99 are carried out by vendor for each design and size of valve to establish the cold working pressure (CWP) rating.

f) The finishing and tolerances of parts like stem, piston, stem threading etc. of the offered valves and manifolds shall be properly machined to avoid problems like galling. g) The hand wheel material for all valves and manifolds shall be zinc/nickel plated carbon steel. Any other material, if provided as per standard vendor design, shall also be acceptable.

3-Valve manifold :

- i. It shall be designed for direct coupling to differential pressure transmitters having 2 bolt flanges with 54mm (2-1/8”) center-to-center connections and 41.3mm (1-5/8”) bolt-to-bolt distance.
- ii. It shall contain two main line block valves and an equalizing bypass valve. The valves shall be needle type. They shall use self-aligning 316 Stainless Steel ball seats, unless otherwise specified.
- iii. The flanges shall be integral part of manifold block.
- iv. The process connection shall be ½”NPTF to ANSI B 1.20.1.
- v. Manifolds for stanchion mounting shall be provided along with mounting accessories. The bolts and nuts shall be alloy steel as per ASTM A 193 Gr B7 and ASTM A194 Gr. 2H (Hot dip galvanised or zinc plated) respectively. Other accessories shall be zinc plated.

**3.5.4 3 way 2 valve manifold for pressure gauges :**

- i. It shall be designed for use with pressure gauges with block and bleed valves. The manifold body shall be either straight or angle type as required.
- ii. The valve shall be a needle type.
- iii. The inlet connection shall be ¾” plain ends with a minimum of 100mm nipple extension suitable for socket weld or butt weld as per B16.11/ B16.9. The gauge connection shall be with union nut and tail piece threaded to ½”NPTF and drain connection shall be ½”NPTF.

For all Valve manifolds material of construction shall be SS316.

5-Valve manifold shall be provided, if specified in the job specifications.

Vendor shall provide a minimum of 20% instrument valves and manifolds as spare.

**3.5.5 Pneumatic Signal Tubes**

- a) Vendor shall provide ¼” OD x 1 mm thick SS316L for pneumatic signal tubes unless specified otherwise.



- b) Vendor shall avoid use of intermediate connections and shall estimate single length for each instrument location.
- c) Vendor shall provide a minimum of 20% length of these tubes as spares.

### **3.5.6 Instrument Air Lines Fittings and Valves**

- a) Instrument air lines and fittings shall be as per piping class unless specified otherwise.
- b) Isolation valves on instrument air service shall be packless gland type full bore ball valves of SS.
- c) Vendor shall provide a minimum of 20% of air pipe, fittings and valves as spare.

### **3.5.7 Stainless Steel Tube Fittings**

- a) Fittings shall be of flare less compression type having four-piece (for double compression type) construction consisting of two ferrules, nut and body or three piece (compression type) construction consisting of single ferrule, nut and body suitable for use on tubes of specified material for example stainless steel tubes conforming to ASTM A269 TP 316L with hardness in the range of HRB 70 to 79.
- b) All parts of the tube fittings shall be of SS316.
- c) Hardness of the ferrules shall be in the range of HRB 85-90 so as to ensure a hardness difference of the order of 5 to 10 between tube and fittings for better sealing.
- d) Nuts and ferrules of a particular size shall be interchangeable for each type.
- e) Specific techniques like silver plating shall be used over threading in order to avoid jamming and galling.
- f) Ferrule finish and fitting finish shall be such that there is no abrasion/galling when the nut is tightened.

## **3.6 Specification for Erection E,C&I Items**

### **3.6.1 IMPULSE LINE REQUIREMENTS**

- 1 All instrument impulse shall be provided with the following.
  - i) Piping or tubing or combination of piping and tubing shall be as per requirement of job specification or licensor's requirements.
  - ii) All instruments shall be provided with isolation, drain and/ or vent valves with vent/drain end duly capped. This isolation valve shall be in addition to the first isolation /root valve provided on the pipe or vessel at instrument take off.
  - iii) For flow transmitters integral 3 valve manifold shall be provided.
  - iv) For remote installation of instrument minimum one pair of break flanges shall be provided.
  - v) For diaphragm seal type instruments, spacer ring with vent and drain connection along with vent / drain valve with end capped.
  - vi) For instrument flushing/purging line additionally check valve, rotameter, DP regulator, restriction orifice with isolation valves shall be provided.
  - vii) All the valves used for impulse line (isolation, vent and drain) shall be gate type.
  - viii) Vendor to study all the installations and meters shall be provided above the tapping for all types of condensable vapour service.
  - ix) Syphon shall be used for steam service.
  - x) Extension in the impulse piping / tubing of suitable length may have to be provided for those instrument installations where process fluid temperature is higher than the maximum withstanding temperature of the instrument / diaphragm.

Piping standard shall be used for all installation where specified in job specification. For rating upto 600 #, the connection to the transmitters shall be with a male connector and tubing 1/2" OD. For rating higher than 600 #, no tubing shall be used. The connection to the transmitters shall be with 1/2" piping with flanges in between. For piping standard, all pipes shall be 1/2" NB



**SPECIFICATION FOR ELECTRICAL  
CONTROL & INSTRUMENTATION**

**SPEC. NO.: ROS 4085**

**REV. NO: 00**

unless higher sizes required to meet the requirements, with all fittings suitable for the piping. All the joints shall be welded or flanged as required. For instrument end connection i.e root valve of orifices and other items, level gauges vent and drain connection, seal welding shall be provided. For non diaphragm seal instruments and instruments where provided with threaded connection, no welding is required at instrument end. Thickness of impulse piping upto 300# rating shall be sch 80 and above 300# rating shall be Sch 160.

Tube standard shall be used upto 600 # only where the same is required as per job specification. For rating above 600 # and hydrogen/lethal service, only piping standard shall be used. The tubing shall be 1/2" OD tube with all fittings suitable for the same. Valves used shall be threaded. At the first isolation / root valve end suitable pipe tag to tubing conversion fittings shall be used. For remote installation suitable unions / couplings shall be used.

For Pre-Fabricated Installation/hook-Ups the following guidelines shall be followed.

- a) Pre-fabricated hook ups shall be provided for flow, pressure etc.
- b) The Pre-Fabricated Hook up shall be provided with Instrument isolation valve, equalizing valves, drain/ vent valves and shall be integral type. The piping isolation valve/ root valve shall be separate and shall be provided as part of piping.
- c) Material for pre-fabricated Hook up/ installation integral with manifold shall be as per piping, as a minimum. However SS316 is also acceptable for carbon steel piping meeting the rating and other piping requirements. The valve internals shall be as per piping specifications. The Instrument isolation valves shall be globe type in general.
- d) Selection of pre-fabricated hook ups shall be considered based on tapping orientation.
- e) For pre-fabricated hook up vent/ drain valve shall be quarter turn ball or globe type valve as per vendor standard design.
- f) Flanged or welded connection type for hook-up materials shall be selected based on PMS.
- g) Suitable pipe support shall be provided for fabricated installation/ Hook-Ups.

Vendor shall consider suitable clearance during installation.

Based on above guideline, Vendor shall prepare, develop installation standards and indicate bill of material for each installation.

### **3.6.2 Grounding**

- a) Each cabinet, console and other equipment provided as a part of system shall have earthing lugs which shall be secured to the 'AC mains earthing bus'.
- b) All circuit grounds, shields and drain wires shall be connected to the 'system ground' bus which is isolated from 'AC mains earth'. This bus shall typically be 25 mm wide and 6 mm thick of copper.

The total resistance of system ground shall be less than 5  $\Omega$  unless otherwise recommended by system manufacturer.

- c) Safety barriers, if used, shall be secured to 'Safety ground' which shall have typically ground resistance of less than 1  $\Omega$ . The bus shall be designed considering a fault level of 0.5 A at 250 V r.m.s. per barrier.

All other installation guidelines as recommended by system manufacturer shall be followed.

## **4.0 Mandatory Spares**

<b>SI.No</b>	<b>PART DESCRIPTION</b>	<b>QUANTITY REQUIRED</b>
1	Field Instruments such as Pressure Gauges, Temperature Gauges with Thermowell , Differential Pressure Gauges, ft Gauge, Field Indicators, RTD/ Thermocouple (with Thermowell), Thermowells, Skin Thermocouple Sets, Cool down Temperature Elements, speed probe and transmitters (Note-5)	10% subject to minimum 1 No. of each type



## SPECIFICATION FOR ELECTRICAL CONTROL & INSTRUMENTATION

SPEC. NO.: ROS 4085

REV. NO: 00

2	Smart Transmitters for Pressure, Level (excluding radar and displacer transmitters), Flow (DP type only), Temperature & Differential Pressure (complete transmitter) (Note-5)	10% subject to minimum 1 No. of each type
4	All type of Switches (in case given in place of transmitters as a special case because of statutory / special applications) (Note-5)	10% subject to minimum 1 No. of each type
6	Instrument valves and manifolds	20% minimum of each type
	SS Tubes for Instrument Impulse line & 1/4" OD Pneumatic air tubing	20% minimum of each type

### NOTES:

1. The word 'TYPE' means the Make, Model no., Type, Range, Size/ Length, Rating, Material, accessories as applicable.
2. Wherever % age is identified, Vendor shall supply next higher rounded figure.
3. The terminology used under 'Part Description' is the commonly used name of the part and may vary from manUfacturer to manUfacturer.
4. Commissioning spares are part of Vendor scope of supply. Mandatory spares as indicated above do not cover commissioning spares.
5. Spares for Instruments shall be supplied alongwith the applicable accessories as mandatory spares. No accessories shall be supplied separately as mandatory spare.
- 6 The above mandatory spares are to be supplied along with main system .

## **5.0 Commissioning Spares**

For successful pre-commissioning, commissioning and performance testing, requirements of spares are to be provided by the contractor within quoted lump sum price and are to be listed in the bid. Any additional spares used shall be to Contractor's account. Any kind of spares required for start-up and commissioning shall be provided.

## **6.0 Two years operational spares List (optional)**

Unless otherwise specified in the job specifications, all spares for 2 years of normal operation like gaskets, O-rings, diaphragms etc. as required for all instruments for two years of trouble free operation shall be quoted separately & will not be considered for bid evaluation.

Unit rate of all items instruments, instrument cables, instrument valves manifolds and hardware shall be indicated by Vendor for any future addition/deletion for system related items. This price shall include all engineering charges, installation, software charges etc. related to the effected addition/deletion.

## **7.0 COMMISSIONING**

- a. This activity shall be carried out in a systematic manner so as to avoid any accident to plant and operating personnel.
- b. During the plant start up all the instruments calibration, controller alignment, trip point settings shall be trimmed so as to meet the operation requirements.
- c. Prior to guarantee run of any unit, the vital instruments as required by Vendor have to be recalibrated and the results recorded.
- d. As built drawings shall be prepared after installation and commissioning is over.



### **8.0 Customer Approved Vendor List (ANNEXURE ECI-2)**

Vendor List for Instrumentation items is provided in the specification. Vendor shall consider the instrument supplier as identified in the Vendor List. Vendor list provided in the package is for the Make only, and not for any specific Model.

For any instrumentation item, the offered model for the same must meet the specification and proven track record (PTR) requirement. For all special Instruments and systems like On-off valves, field instruments, Analysers, PLC system, EIL(PMC) approved vendor List shall be followed. This is applicable for skid mounted instruments as well.

### **9.0 SCHEDULES**

#### **9.1) Schedule of Technical Confirmations – Schedule-A**

(Please indicate Yes / No)

1.	All the items / equipments / instruments as per Enquiry / PID are included in the scope	
2.	All the items / equipments / instruments are manUfactured and tested as per relevant codes and standards.	
3.	All the items / equipment / instruments meet Enquiry technical BHEL specification	
4.	Erection of all supplied instruments and equipment included in scope	
5.	Laying & termination of cables included in scope	
6.	Laying & termination of SS impulse line for instruments included in scope	
7.	Laying & termination of SS tube for POV's included in scope	
8.	Pre commissioning checks will be included in scope	
9.	Commissioning included in the scope	
10.	Training at vendor's works and at site included in scope	
11.	Makes of all instruments and equipment will be as per the BHEL specification	
12.	Site specific Programming assistance for purchaser's PLC included in scope	
13.	Calibration at manUfacturer's works included in scope	
14.	Calibration at site included in scope	
15.	Supply of commissioning spares included in scope	
16.	Supply of Tools & tackles included in scope	
17.	Supply of hand held programmer kit / calibrator suitable for all instruments included in scope	
18.	Supply of VFD panels (if any) included in scope	
19.	Supply of all calibration liquid, powder as per the BHEL specification included in scope.	
20.	In the event of order all drawings datasheets and documents as per the BHEL specification will be submitted to BHEL for approval.	
21.	All instruments / JB's/ SVEB's will be provided with Double Compression type cable glands and Annealed Tinned copper lugs	



**SPECIFICATION FOR ELECTRICAL  
CONTROL & INSTRUMENTATION**

**SPEC. NO.: ROS 4085**

**REV. NO: 00**

22.	Operation and maintenance manual in required numbers will be supplied for all items	
23.	Erection materials like Root valves, 3 way manifolds, impulse piping required for installing all instruments will be included in scope	
24.	Supply of cable trays, glands, lugs included in scope	
25.	Number of Digital inputs to be provided in PLC	Indicate quantity
26.	Number of Digital outputs to be provided in PLC	Indicate quantity
27.	Number of Analogue inputs to be provided in PLC	Indicate quantity
28.	Number of Analogue outputs to be provided in PLC	Indicate quantity
29.	Site support for auto operation through PLC as per Enquiry included in scope	
30.	Unit price for addition deletion as per Enquiry furnished in the Price Bid	



**TYPE 11 SINGLE INSTRUMENT SUPPORT - GENERAL ARRANGEMENT**

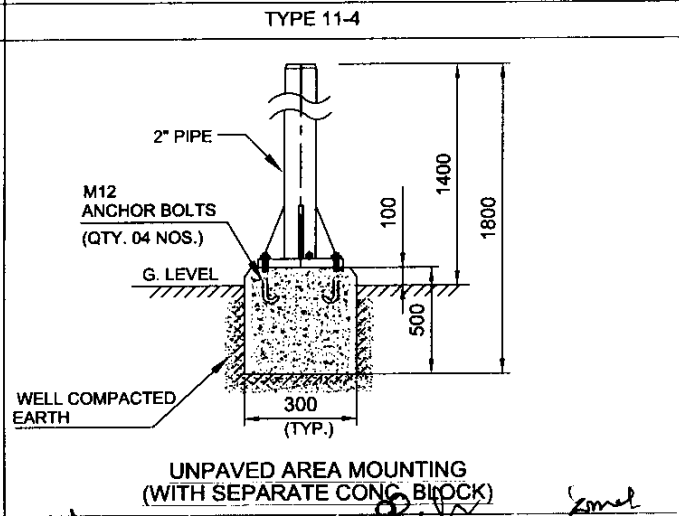
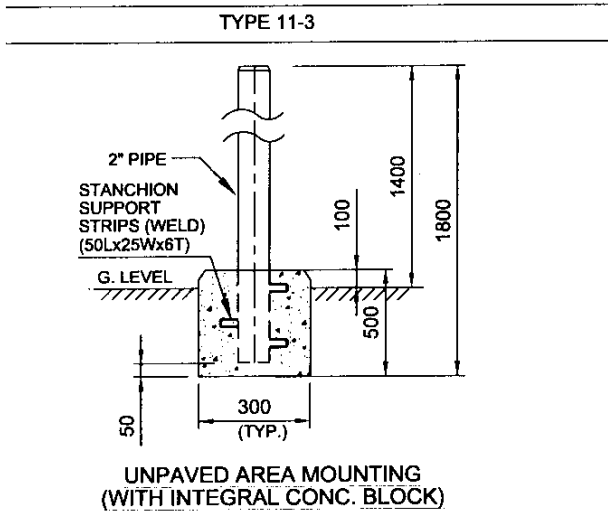
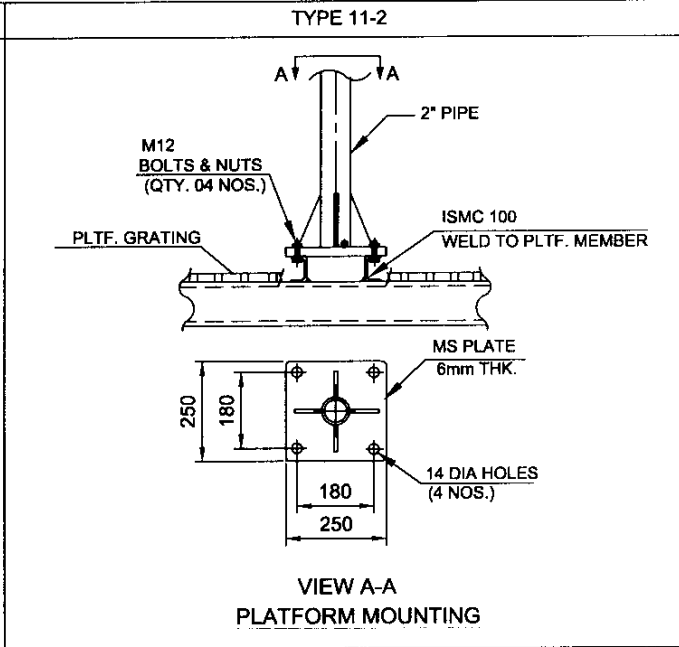
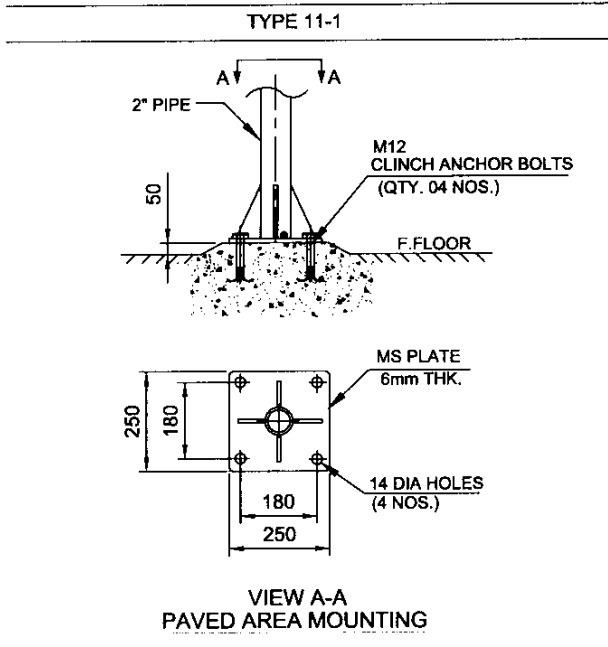
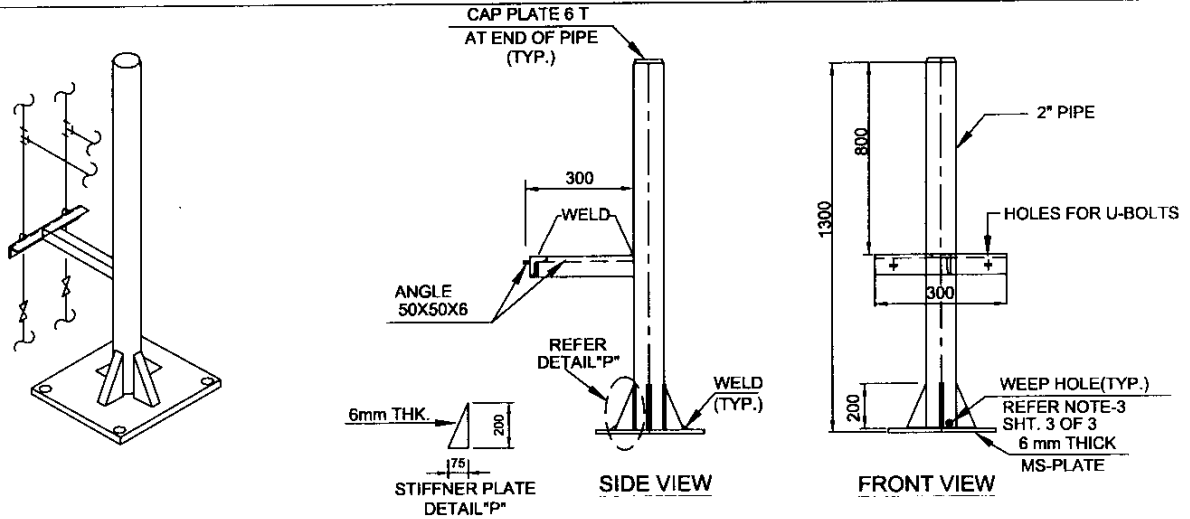

2	14-11-11	Revised & Reissued	Manoj	RG	RP/JMS	DM
1	01-09-06	Reaffirmed and Reissued	MN	TGM	PM	VC
Rev. No.	Date	Purpose	Prepared by	Checked by	Stds. Committee Convener	Stds. Bureau Chairman
Approved by						

TYPE 12

CONCRETE COLUMN MOUNTING

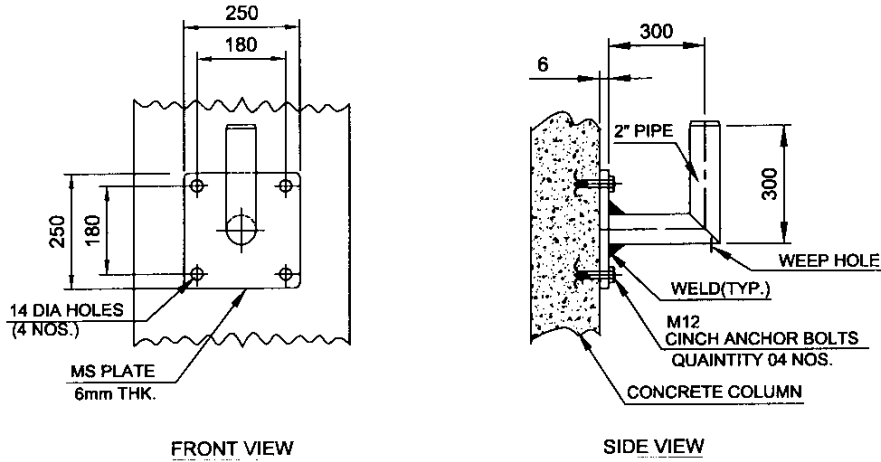

TYPE 13

CONCRETE COLUMN (WITH ANGLE INSERT) MOUNTING

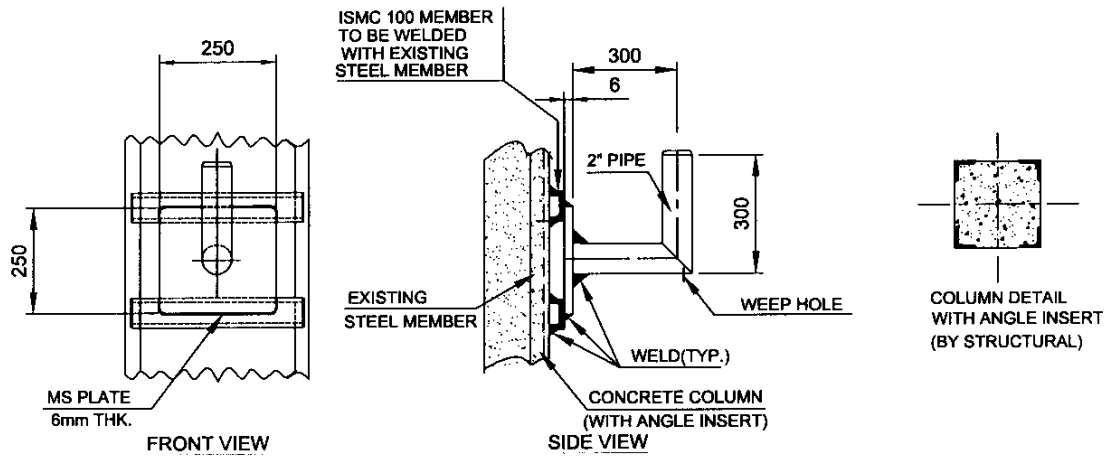

TYPE-14

CONCRETE COLUMN (WITH INSERT PLATE) MOUNTING

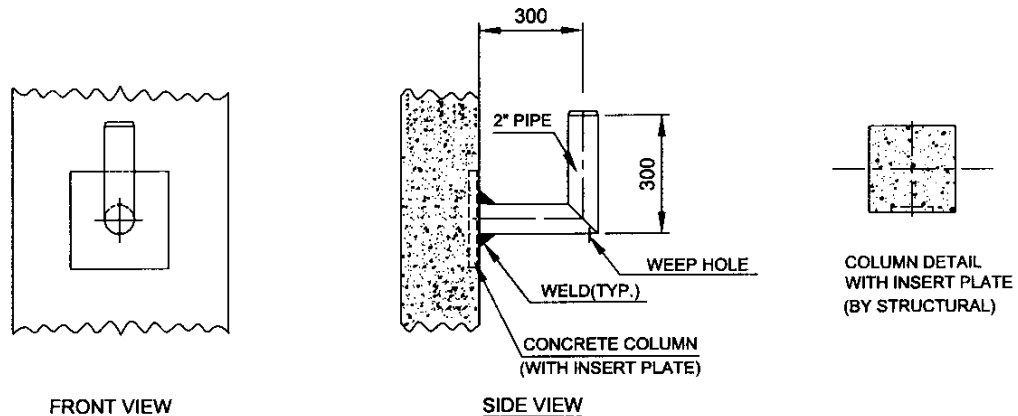

2	14-11-11	Revised & Reissued	Manoj	RG	RP/JMS	DM
1	01-09-06	Reaffirmed and Reissued	MN	TGM	PM	VC
Rev. No.	Date	Purpose	Prepared by	Checked by	Stds. Committee Convenor	Stds. Bureau Chairman
						Approved by

**TYPE 15**

**STEEL COLUMN MOUNTING (FLANGE FACE)**

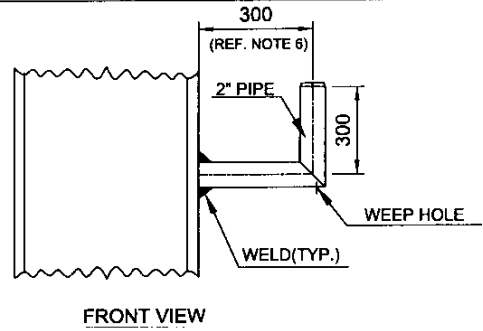
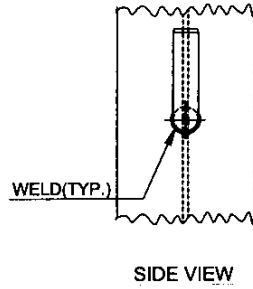
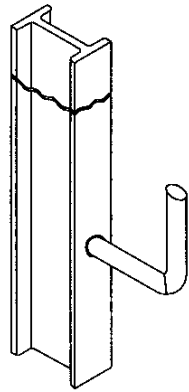

**TYPE 16**

**STEEL COLUMN MOUNTING (WEB FACE)**

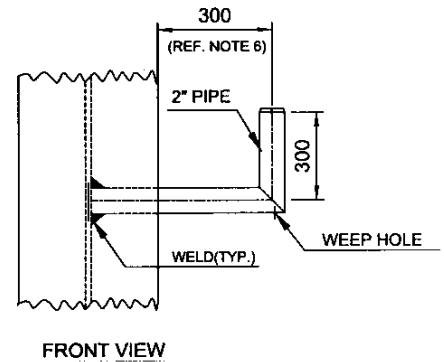
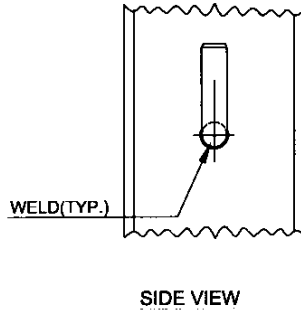
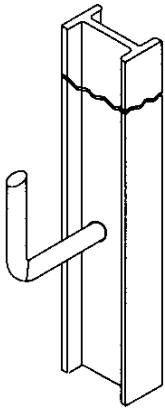

**TYPE 17**

**PIPE BRACKET MOUNTING**

**TYPE 17.1 (VERTICAL PIPE)**

**TYPE 17.2 (HORIZONTAL PIPE)**

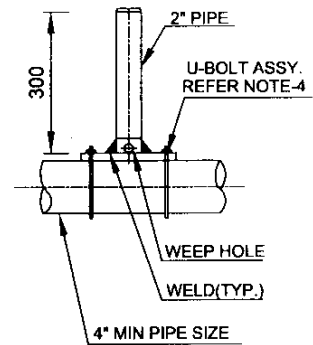
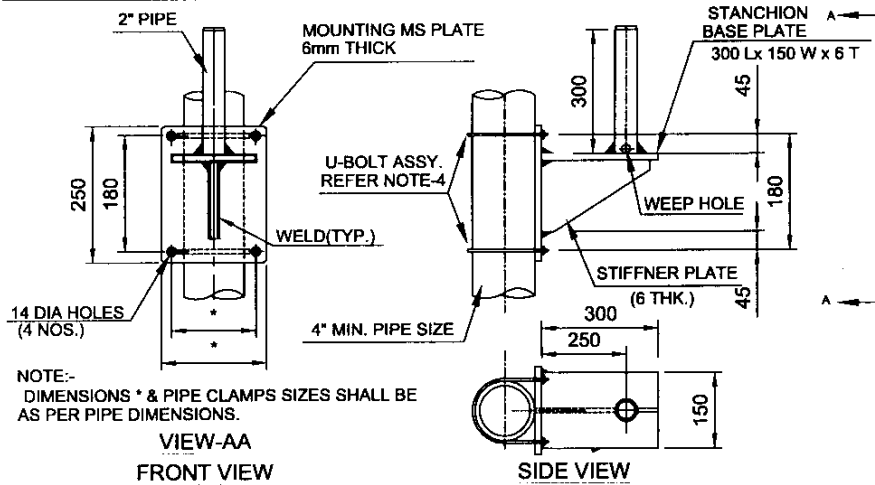

- NOTES:-**
1. ALL DIMENSIONS ARE IN M.M. UNLESS OTHERWISE SPECIFIED.
  2. PIPE MATERIAL SHALL BE IS:1239 HEAVY GRADE AS A MINIMUM.
  3. 6 mm DIA WEEP HOLE SHALL BE PROVIDED AT LOW POINT.
  4. U-BOLT ASSEMBLY SHALL BE OF MINIMUM M12 SIZE WITH NUTS AND SPRING WASHERS.
  5. ALL WELD SHALL BE 3mm FILLET WELD FULL STRENGTH.
  6. ADD 50mm WHERE-EVER FIRE INSULATION IS PROVIDED.
  7. BOLT SHALL BE TURNED FROM M.S. ROUNDS CONFIRMING TO IS : 432 GRADE 1.
  8. NUTS AND WASHERS SHALL CONFIRM TO IS : 1363 AND IS : 3138.

2	14-11-11	Revised & Reissued	Manoj	RG	RP/JMS	DM
1	01-09-06	Reaffirmed and Reissued	MN	TGM	PM	VC
Rev. No.	Date	Purpose	Prepared by	Checked by	Stds. Committee Convener	Stds. Bureau Chairman
Approved by						

TRAY ARRANGEMENT FOR JUNCTION BOXES

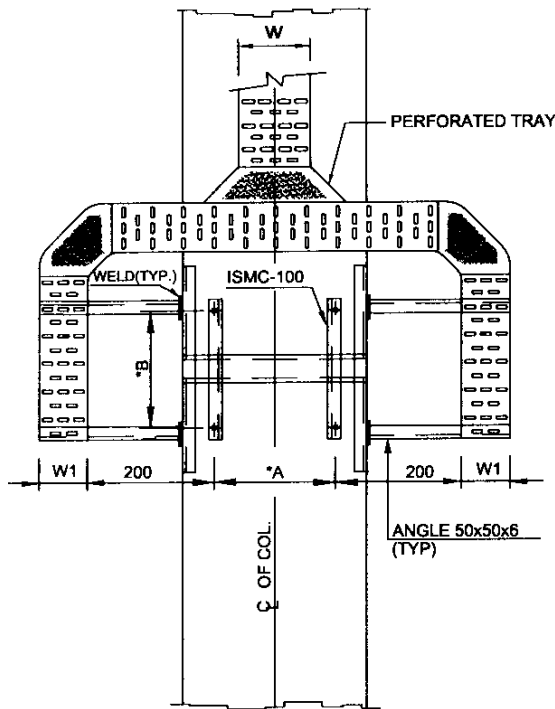

CABLE ROUTING FOR JUNCTION BOXES.

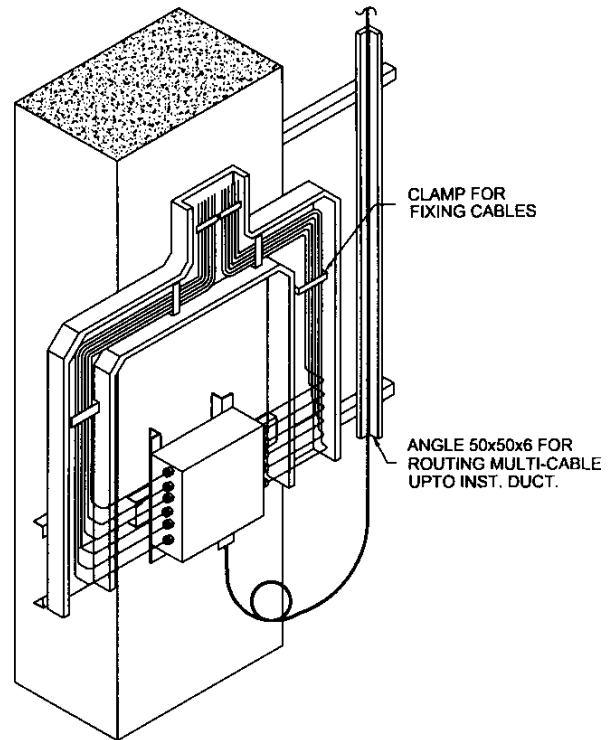

JN. BOX MOUNTING FRAME (R.C.C. COLUMN)

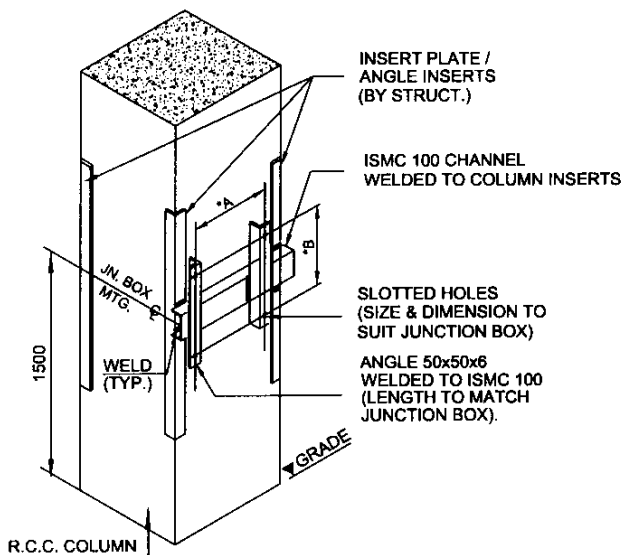

JN. BOX MOUNTING FRAME (STEEL COLUMN)

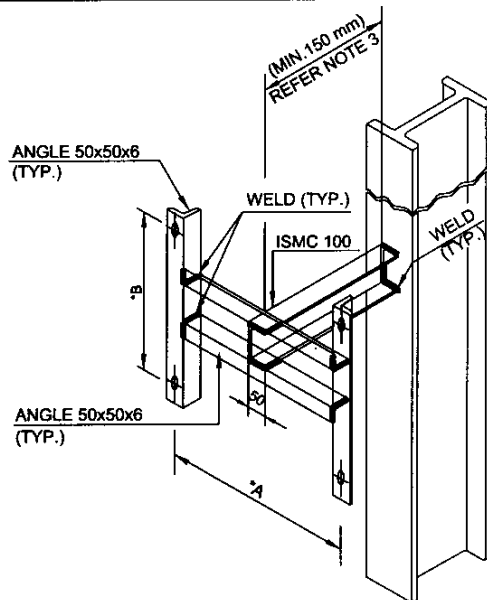

\* DIMENSION 'A' and 'B' TO SUIT JUNCTION BOX.

- NOTE: 1. ALL DIMENSIONS ARE IN mm.  
 2. CLAMP MULTICABLE ON ANGLE WITH 25mm WIDE PVC COVERED ALLUMINIUM STRIP.  
 3. ADD 50 mm WHERE-EVER FIRE INSULATION IS PROVIDED.

TRAY WIDTH

JN. BOX	W	W1
12 PAIR	300	150
8 TRIAD	300	150
6 PAIR	150	100
4 TRIAD	150	100

2	14-11-11	Revised & Reissued	Manoj	RG	RP/JMS	DM
1	01-09-06	Reaffirmed and Reissued	MN	TGM	PM	VC
Rev. No.	Date	Purpose	Prepared by	Checked by	Stds. Committee Convener	Stds. Bureau Chairman
Approved by						

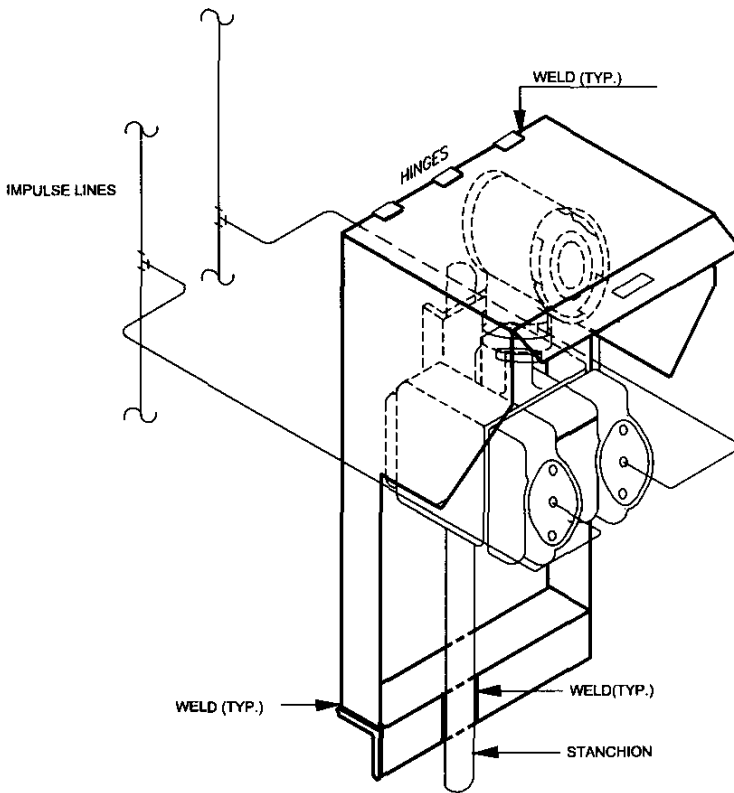
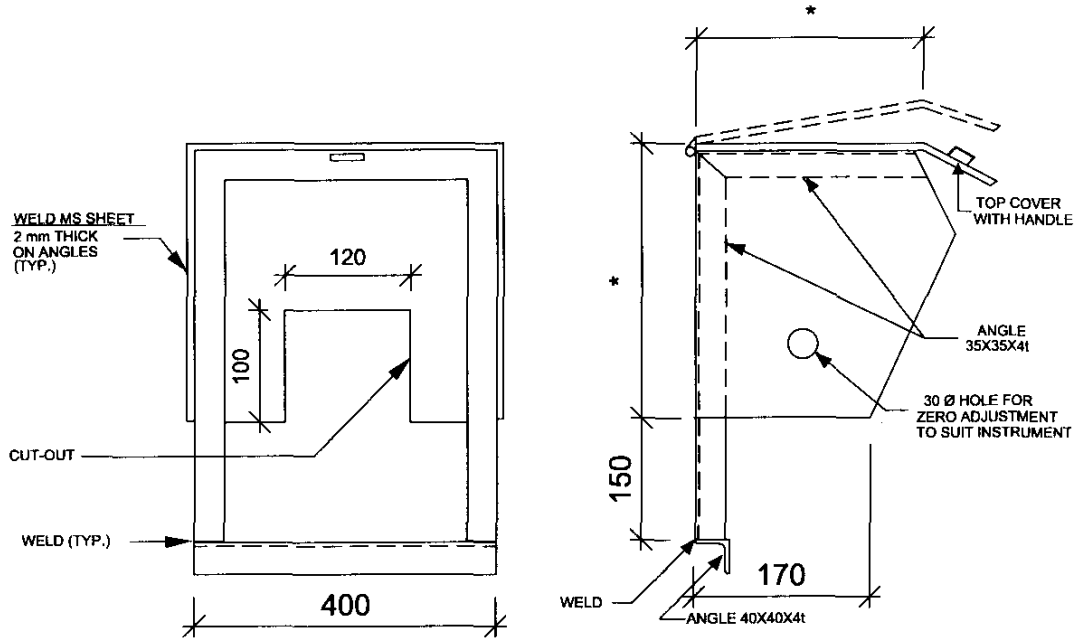

NOTES :

1. ALL DIMENSIONS ARE IN mm
2. \* - TO SUIT INSTRUMENT DIMENSIONS
3. HINGES SHALL BE OF STAINLESS STEEL.
4. A MINIMUM OF TWO COATS PAINTING SHALL BE CARRIED OUT AFTER A MINIMUM OF ONE COAT OF RED OXIDE ZINC CHROMATE PRIMER. THE COLOUR OF THE PAINT SHALL BE AS PER IS-5.

2	14-11-11	Revised & Reissued	Manoj	RG	RP/JMS	DM
1	01-09-06	Reaffirmed and Reissued	MN	TGM	PM	VC
Rev. No.	Date	Purpose	Prepared by	Checked by	Stds. Committee Convener	Stds. Bureau Chairman
Approved by						

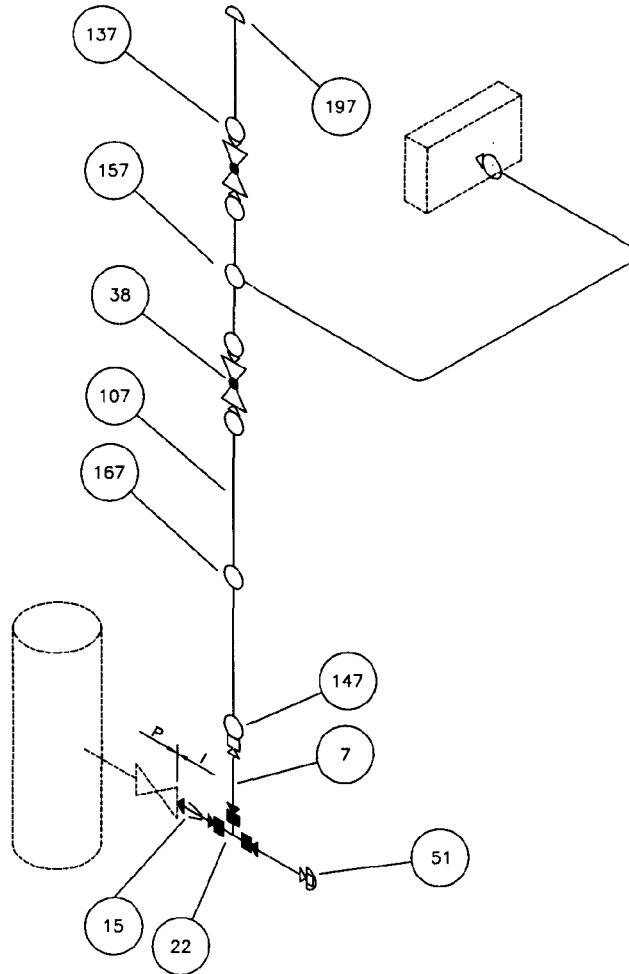

LIST OF ITEMS

CODE	DESCRIPTION	SIZE	ENDS	QTY.	UNIT	CODE	DESCRIPTION	SIZE	ENDS	QTY.	UNIT
7	NIPPLE	1/2"	TH X PL	2	Nø	107	TUBE	1/2"	OD	A/R	m
15	SWAGE NIPPLE	3/4" X 1/2"	PL X PL	1	Nø	137	MALE CONNECTOR	1/2" X 1/2"	TH X OD	5	Nø
22	EQUAL TEE	1/2"	SW	1	Nø	147	FEMALE CONNECTOR	1/2" X 1/2"	TH X OD	1	Nø
38	GLOBE VALVE	1/2"	TH	2	Nø	157	UNION TEE	1/2"	OD	1	Nø
51	CAP	1/2"	TH	1	Nø	167	TUBE UNION	1/2"	OD	1	Nø
						197	TUBING CAP	1/2"	OD	1	Nø

4	01-08-11	Revised & Reissued	Manoj	RG	RP/JMS	DM
3	07-08-06	Reaffirmed and Reissued	MN	TGM	PM	VJN
Rev. No.	Date	Purpose	Prepared by	Checked by	Stds. Committee Convener	Stds. Bureau Chairman
					Approved by	

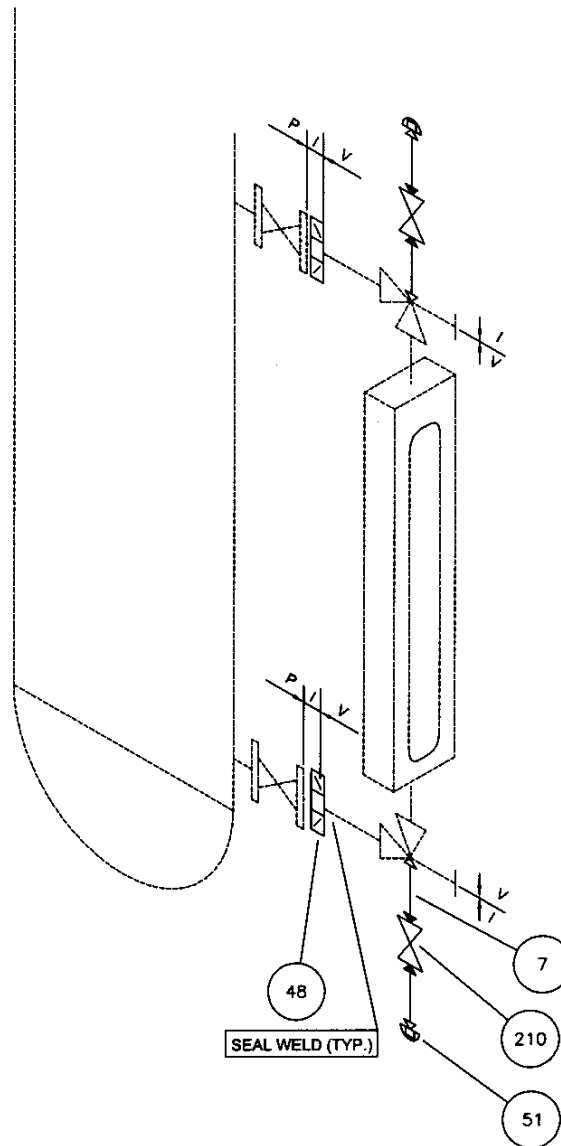

P - BY PIPING  
I - BY INSTRUMENTATION  
V - BY INSTRUMENT VENDOR

LIST OF ITEMS

CODE	DESCRIPTION	SIZE	ENDS	QTY.	UNIT	CODE	DESCRIPTION	SIZE	ENDS	QTY.	UNIT
7	NIPPLE	1/2"	TH X PL	4	Nø						
48	FLANGE	2" X 3/4"	FL X TH (Red)	2	Nø						
51	CAP	1/2"	TH	2	Nø						
210	GATE VALVE	1/2"	SW	2	Nø						

4	12-10-11	Revised and Reissued	Manoj	RG	RP/JMS	DM
3	07-08-06	Reaffirmed and Reissued	MN	TGM	PM	VJN
Rev. No.	Date	Purpose	Prepared by	Checked by	Stds. Committee Convenor	Stds. Bureau Chairman
					Approved by	

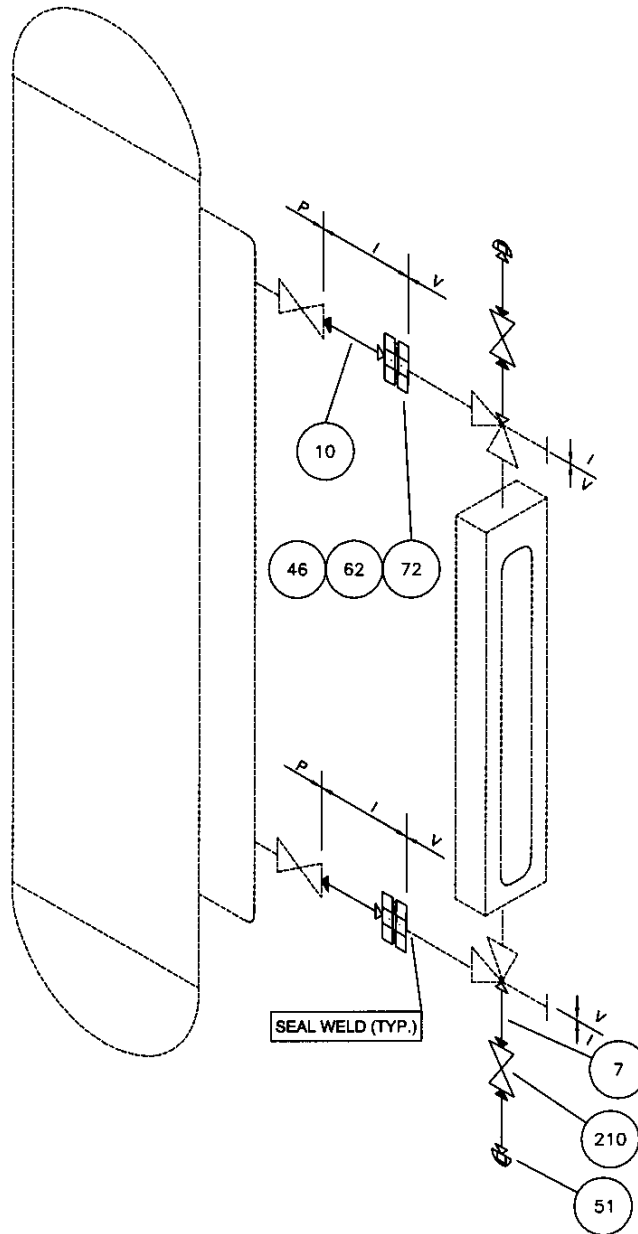

P - BY PIPING  
I - BY INSTRUMENTATION  
V - BY INSTRUMENT VENDOR

**LIST OF ITEMS**

CODE	DESCRIPTION	SIZE	ENDS	QTY.	UNIT	CODE	DESCRIPTION	SIZE	ENDS	QTY.	UNIT
7	NIPPLE	1/2"	TH X PL	4	No						
10	NIPPLE	3/4"	TH X PL	2	No						
46	FLANGE	3/4"	TH	4	No						
51	CAP	1/2"	TH	2	No						
62	GASKET	FOR 3/4" FL		2	No						
72	STUDS & NUTS	FOR 3/4" FL		2	Set						
210	GLOBE VALVE	1/2"	SW	2	No						

2	12-10-11	Revised and Reissued	Manoj K	ARG	RP/JMS	DM
1	07-08-06	Reaffirmed and Reissued	MN	TGM	PM	VJN
Rev. No.	Date	Purpose	Prepared by	Checked by	Stds. Committee Convenor	Stds. Bureau Chairman
						Approved by

DAHEJ PETROCHEMICAL COMPLEX CLIENT: -MIS OP&L	REV.	DATE	REVISION	BY	CHECKED	AUTHOR
	0	01.07.09	ISSUED AS JOB STANDARD	Revinder		RG

The drawing, design and details given on this format are the property of ENGINEERS INDIA LIMITED. They are merely loaned on the borrower's express agreement that they will not be reproduced, copied, exhibited or used, except in the limited way permitted by a written consent given by the lender to the borrower for the intended use.

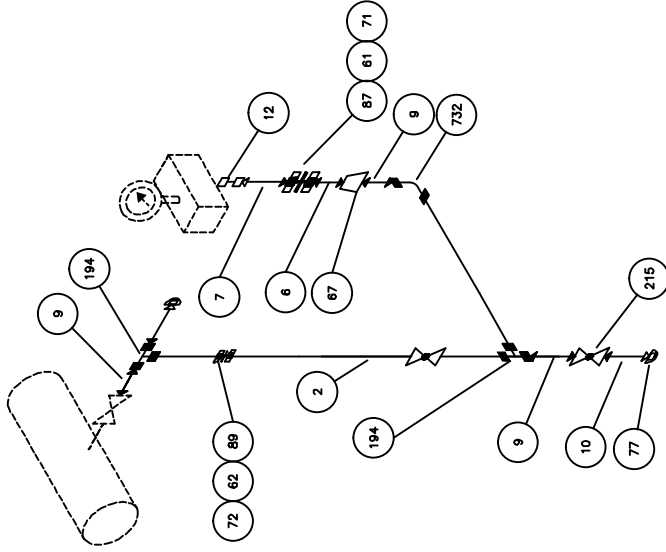

CODE	DESCRIPTION	SIZE	ENDS	QTY.	UNIT	DESCRIPTION	SIZE	ENDS	QTY.	UNIT
2	PIPE	3/4"	PL	1	m	GASKET	FOR 1/2" FL		1	No
6	NIPPLE	1/2"	PL X PL	1	No	STUDS & NUTS	FOR 1/2" FL	WN	1	Set
7	NIPPLE	1/2"	PL X TH	1	No	FLANGE	3/4"		2	No
9	NIPPLE	3/4"	PL X PL	3	No	GASKET	FOR 3/4" FL		1	No
10	NIPPLE	3/4"	TH X PL	2	No	STUDS & NUTS	FOR 3/4" FL		1	Set
12	COUPLING	1/2"	TH	1	No					
67	REDUCER	3/4" X 1/2"	BW	1	No					
194	ELEWOW	3/4"	BW	2	No					
732	ELEWOW	3/4"	BW	1	No					
215	GLOBE VALVE	3/4"	BW	2	No					
87	FLANGE	3/4"	WN	2	No					
77	CAP	3/4"	TH	2	No					

LIST OF ITEMS

 <b>ENGINEERS INDIA LIMITED</b> NEW DELHI	PRESSURE GAUGE ON PUMP DISCHARGE / REMOTE MOUNTED	DRAWING NO.	REV.
		6987-017-16-51-IS-0013	0

DAHEJ PETROCHEMICAL COMPLEX	REV.	DATE	REVISION	BY	CHECKED	AUTHOR
CLIENT: -MIS OP&L	0	01.07.09	ISSUED AS JOB STANDARD	Ravinder		RG

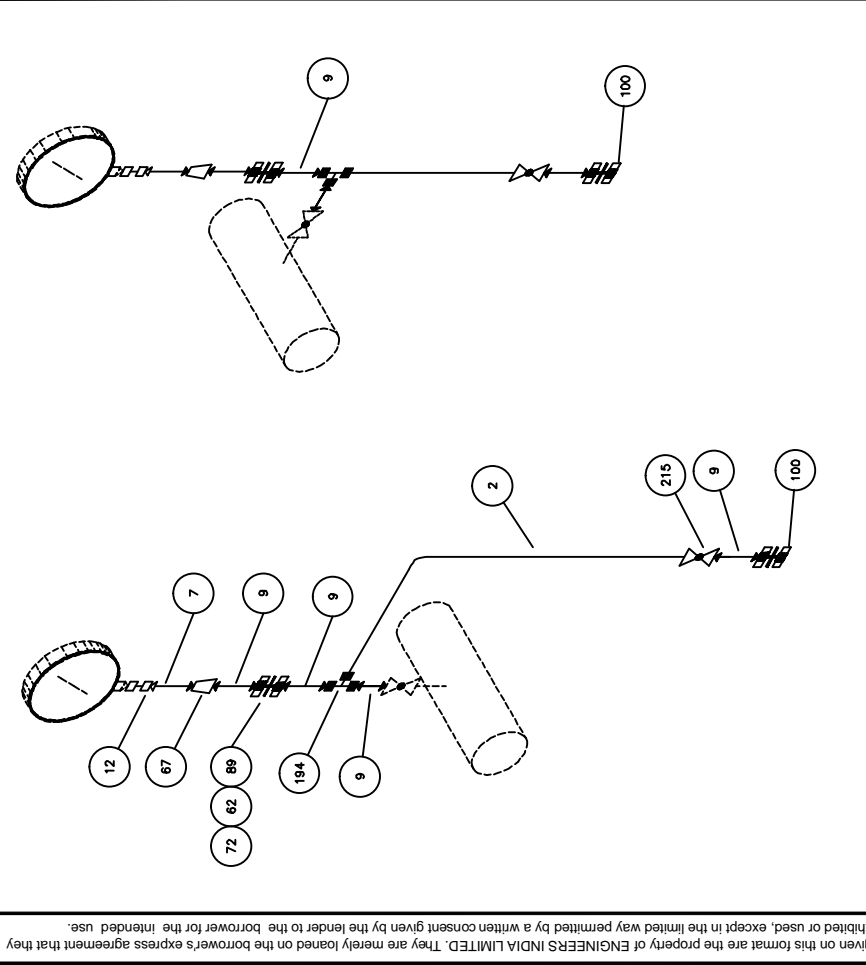

The drawing, design and details given on this format are the property of ENGINEERS INDIA LIMITED. They are merely loaned on the borrower's express agreement that they will not be reproduced, copied, exhibited or used, except in the limited way permitted by a written consent given by the lender to the borrower for the intended use.

CODE	DESCRIPTION	SIZE	ENDS	QTY.	UNIT	DESCRIPTION	SIZE	ENDS	QTY.	UNIT
2	PIPE	3/4"	PL		m					
9	NIPPLE	3/4"	PL X PL	4	No					
7	NIPPLE	1/2"	TH X PL	1	No					
12	COUPLING	1/2"	TH	1	No					
67	REDUCER	3/4" X 1/2"	BW	1	No					
89	EQUAL TEE	3/4"	BW	1	No					
215	GLOBE VALVE	3/4"	BW	1	No					
89	FLANGE	3/4"	WN	3	No					
100	BLIND FLANGE	3/4"		1	No					
62	GASKET	FOR 3/4" FL		2	No					
72	STUDS & NUTS	FOR 3/4" FL		2	Set					

LIST OF ITEMS

 <b>ENGINEERS INDIA LIMITED</b> NEW DELHI	PRESSURE GAUGE LIQUID / GAS SERVICE	DRAWING NO. <b>6987-017-16-51-IS-0014</b>	REV. <b>0</b>
			SH. 1 OF 1

**INSTRUMENT CONNECTION ON VESSEL, STANDPIPES AND TANKS**

**INSTRUMENT CONNECTION ON VESSEL, STANDPIPES AND TANKS**

0	10.07.09	ISSUED AS JOB STANDARD	AR	AA	RG
<b>Rev. No.</b>	<b>Date</b>	<b>Purpose</b>	<b>Prepared by</b>	<b>Checked by</b>	<b>Approved by</b>

SR. NO	TYPE OF INSTRUMENTS	UNCLADDED EQUIPMENTS		CLADDED EQUIPMENTS		INSTRUMENT CONNECTION
		EQUIPMENT/STANDPIPE	FIRST ELCOCK VALVE	EQUIPMENT/STANDPIPE CONNECTION	FIRST BLOCK VALVE	
1.	EXTERNAL DISPLACER LEVEL INSTRUMENTS ON EQUIPMENT	2" FLGD.	2" FLGD.	3" FLGD.	3" FLGD.	2" FLGD.
2.	EXTERNAL DISPLACER LEVEL INSTRUMENTS ON STANDPIPE	2" FLGD.	2" FLGD.	3" FLGD.	2" FLGD.	2" FLGD.
3.	EXTERNAL GUIDED WAVE LEVEL INSTRUMENT ON EQUIPMENT	2" FLGD.	2" FLGD.	3" FLGD.	3" FLGD.	2" FLGD.
4.	EXTERNAL GUIDED WAVE LEVEL INSTRUMENT ON STANDPIPE	2" FLGD.	2" FLGD.	3" FLGD.	2" FLGD.	2" FLGD.
5.	EXTERNAL MAGNETIC LEVEL INSTRUMENT ON EQUIPMENT	2" FLGD.	2" FLGD.	3" FLGD.	3" FLGD.	2" FLGD.
6.	EXTERNAL MAGNETIC LEVEL INDICATOR ON STANDPIPE	2" FLGD.	2" FLGD.	2" FLGD.	2" FLGD.	2" FLGD.
7.	EXTERNAL BALL FLOAT LEVEL INSTRUMENTS ON VESSEL	2" FLGD.	2" FLGD.	3" FLGD.	3" FLGD.	1" SW
8.	EXTERNAL BALL FLOAT LEVEL INSTRUMENTS ON STANDPIPE	1" SW/BW/FLGD #	1" SW/BW/FLGD #	1" SW/BW/FLGD #	1" SW/BW/FLGD #	1" SW
9.	INTERNAL DISPLACER / FLOAT LEVEL INSTRUMENTS	4" FLGD	-	4" FLGD	-	4" FLGD.
10.	INTERNAL GUIDED WAVE LEVEL INSTRUMENT ON EQUIPMENT	4" FLGD.	-	4" FLGD.	-	4" FLGD.
11.	MAGNETIC LEVEL INDICATOR (INTERNAL - TOP MOUNTED)	4" FLGD.	-	4" FLGD.	-	4" FLGD.
12.	LEVEL GAUGE ON VESSEL		2" FLGD.		3" FLGD.	3/4" SCR.D.
13.	LEVEL GAUGE ON STANDPIPE	3/4" SW/BW/FLGD #	3/4" SW/BW/FLGD #	3/4" SW/BW/FLGD #	3/4" SW/BW/FLGD #	3/4" SCR.D.
14.	SPECIAL LEVEL INSTRUMENTS ON EQUIPMENT (CAPACITANCE PROBE/ULTRASONIC PROBE/R.F. PROBE)	2" FLGD.	-	3" FLGD.	-	2" FLGD.
15.	D.P. INSTRUMENTS ON VESSEL	2" FLGD.	2" SW/BW/FLGD #		3" FLGD.	1/2" SCR.D.
16.	D.P. INSTRUMENTS ON STANDPIPE	3/4" SW/BW/FLGD #	3/4" SW/BW/FLGD #	3/4" SW/BW/FLGD #	3/4" SW/BW/FLGD #	1/2" SCR.D.
17.	DIAPHRAGM SEAL D.P. INSTRUMENTS ON VESSEL	4" FLGD. (NOTE-1)	3" FLGD.		3" FLGD.	3" FLGD.
18.	EXTENDED DIAPHRAGM SEAL D.P. INSTRUMENTS ON VESSEL	4" FLGD. (NOTE-1)	-	4" FLGD. (NOTE-1)	-	4" FLGD.
19.	DIP TUBE LEVEL INSTRUMENTS	1 1/2" FLGD.	1/2" SW (BY INST)	3" FLGD.	1/2" SW (BY INST)	1/2" SCR.D

NO	TYPE OF INSTRUMENTS	UNCLADDED EQUIPMENTS		CLADDED EQUIPMENTS		INSTRUMENT CONNECTION
		EQUIPMENT/STANDPIPE	FIRST BLOCK VALVE	EQUIPMENT/STANDPIPE CONNECTION	FIRST BLOCK VALVE	
20.	TANK LEVEL INSTRUMENTS (MECH)	1½" FLGD	1½" FLGD (BY INST)			½" SCR D
21.	TANK LEVEL INSTRUMENTS (SERVO) ON ATMOSPHERIC TANKS	6" FLGD.	6" FLGD. (BY INST)			6" FLGD
22	TANK LEVEL INSTRUMENTS (SERVO) FOR PRESSURISED EQUIPMENTS	6" FLGD.	6" FLGD. (BY INST)	6" FLGD.	6" FLGD. (BY INST)	6" FLGD
23.	TANK LEVEL INSTRUMENTS (RADAR) ON ATMOSPHERIC TANK (CLEAN SERVICE)	8" FLGD.			-	8" FLGD.
24.	TANK LEVEL INSTRUMENTS (RADAR) ON ATMOSPHERIC TANK (VISCIOUS SERVICE)	24" FLGD.			-	24" FLGD.
25.	TANK LEVEL INSTRUMENTS (RADAR) FOR PRESSURISED EQUIPMENTS	8" FLGD.	-	8" FLGD.	-	8" FLGD.
26.	TANK LEVEL INSTRUMENTS – CAPTANCE / ULTRASONIC/ RF TYPE ON ATMOSPHERIC TANKS/PRESSURISED EQUIPMENTS	2" FLGD.	-	3" FLGD.	-	2" FLGD.
27.	PRESSURE INSTRUMENTS ON VESSEL	2" FLGD	2" SW/BW/ FLGD #		3" FLGD.	½" SCR D
28.	PRESSURE INSTRUMENTS ON STANDPIPE	¾" SW/BW/ FLGD #	¾" SW/BW/ FLGD #		¾" SW/BW/ FLGD #	½" SCR D
29.	CHEMICAL SEAL PRESSURE INSTRUMENT/ GAUGE ON VESSEL	2" FLGD	2" FLGD		3" FLGD.	½" SCR D
30.	DIAPHRAGM SEAL PRESSURE INSTRUMENT/ GAUGE ON VESSEL	2" FLGD	2" FLGD		3" FLGD.	2" FLGD/ 3" FLGD
31.	THERMOWELL ON EQUIPMENT	2" FLGD	-	3" FLGD.	-	2" FLGD/ 3" FLGD
32.	MULTI-POINT TEMPERATURE ELEMENTS FOR TANKS	3" FLGD.	-	3" FLGD.	-	3" FLGD
33.	STANDPIPE (RATING UP TO 600#)	2" FLGD.	-	3" FLGD.		
34.	STANDPIPE (RATING > 600#)	3" FLGD.	-	3" FLGD.		

- NOTES:**
- 1 NOZZLE ID ON EQUIPMENT SHALL BE SELECTED TO SUIT O.D OF EXTENDED DIAPHRAGM OF INSTRUMENT.
  - 2 ALL FLANGES/SW RATING SHALL BE AS PER PIPING SPECIFICATION.
  - 3 IN CASE OF DIRECT MOUNTED FLANGED INSTRUMENTS AND WHERE FLANGED TYPE FIRST ISOLATION VALVE ARE PROVIDED, BOLTING AND GASKETS SHALL BE IN PIPING SCOPE.
  - 4 INSTALLATION OF TANK LEVEL INSTRUMENTS (SERVO, MECHANICAL AND MULTIPPOINT TEMPERATURE ELEMENT) ON TANKS ARE IN TANK VENDOR SCOPE.
  - 5 FOR ANY OTHER INSTRUMENTS NOT REFERED ABOVE THE CONNECTION DETAILS SHALL BE AS PER INDIVIDUAL REQUIREMENT.
  - 6 NOZZLE SIZES/ RATINGS AS SPECIFIED BY LICENSOR IN VESSEL DATA SHEETS SHALL HAVE PRECEDENCE OVER SIZES GIVEN IN THIS DOCUMENT.
- # AS PER PIPING SPECIFICATION.

## INSTRUMENT CONNECTION ON PIPES

0	10.07.09	ISSUED AS JOB STANDARD	AR	AA	RG
<b>Rev. No.</b>	<b>Date</b>	<b>Purpose</b>	<b>Prepared by</b>	<b>Checked by</b>	<b>Approved by</b>

(A) BARE PIPES

S. NO	TYPE OF INSTRUMENTS	WHERE PIPING CLASS RECOMMENDS SCRD CONNECTION			WHERE PIPING CLASS RECOMMENDS SW/BW # CONNECTION			WHERE PIPING CLASS RECOMMENDS FLGD CONNECTION		
		PROCESS CONNECTION	FIRST BLOCK VALVE	INSTRUMENTS CONNECTION	PROCESS CONNECTION	FIRST BLOCK VALVE	INSTRUMENTS CONNECTION	PROCESS CONNECTION	FIRST BLOCK VALVE	INSTRUMENTS CONNECTION
1	FLOW METER	1/2" SCRD*	1/2" SCRD*	1/2" SCRD	1/2" SCRD*	1/2" SW/BW#	1/2" SCRD	1/2" SCRD*	1/2" SCRD	1/2" SCRD
	ORIFICE			-	3/4" SCRD**	3/4" SW/BW#	1/2" SCRD	3/4" SCRD**	3/4" SCRD**	1/2" SCRD
2	FLOWMETER		1/2" FLGD	1/2" SCRD	1/2" FLGD		1/2" SCRD	1/2" FLGD	1/2" SCRD	1/2" SCRD
	VENTURI/NOZZLE			-	3/4" FLGD	3/4" FLGD	1/2" SCRD	3/4" FLGD	1/2" SCRD	1/2" SCRD
3	FLOW METER	1/2" SCRD*	1/2" SCRD*	3" FLGD	1/2" SCRD*	1/2" SW/BW#	3" FLGD	1/2" SCRD*	1/2" SCRD*	3" FLGD
	ORIFICE (DIAPH. SEAL)			-	3/4" SCRD**	3/4" SW/BW#	3" FLGD	3/4" SCRD**	3/4" SCRD**	3" FLGD
4	FLOW METER	1/2" FLGD	1/2" FLGD	3" FLGD	1/2" FLGD	1/2" FLGD	3" FLGD	1/2" FLGD	1/2" FLGD	3" FLGD
	VENTURI/NOZZLE (DIAPH. SEAL)			-	3/4" FLGD	3/4" FLGD	3" FLGD	3/4" FLGD	3/4" FLGD	3" FLGD
5	FLOW METER AVERAGE PITOT TUBE	3" FLGD (BY INST)	3" FLGD (BY INST)	3" FLGD+	3" FLGD	3" FLGD (BY INST)	3" FLGD	3" FLGD	3" FLGD (BY INST)	3" FLGD+
6	DIFFERENTIAL PRESSURE (DP) INSTRUMENTS	3/4" SCRD*	3/4" SCRD*	1/2" SCRD.		3/4" SW/BW#	1/2" SCRD		3/4" FLGD	1/2" SCRD
7	DIAPHRAGM SEAL D.P. INSTRUMENTS	3" FLGD.	3" FLGD.		3" FLGD.	3" FLGD.	3" FLGD	3" FLGD.	3" FLGD.	3" FLGD.
8	PRESSURE INSTRUMENTS <5>	3/4" SCRD*	3/4" SCRD*	1/2" SCRD.		3/4" SW/BW#	1/2" SCRD.		3/4" SCRD.	1/2" SCRD
9	DIAPH. (CHEMICAL) SEAL PRESSURE INSTRUMENT-> (SCRD.)	3/4" SCRD*	3/4" SCRD*	1/2" SCRD.		3/4" SW/BW#	1/2" SCRD.		3/4" SCRD.	1/2" SCRD
10	DIAPHRAGM SEAL PRESSURE INSTRUMENTS (FLGD.)	1 1/2" FLGD.	1 1/2" FLGD.	1 1/2" FLGD.		1 1/4" FLGD.	1 1/2" FLGD.		1 1/2" FLGD.	1 1/4" FLGD.
11	THERMOWELL	1 1/2" FLGD.	-	1 1/2" FLGD	1 1/2" FLGD.	-	1 1/2" FLGD	1 1/2" FLGD.	-	1 1/2" FLGD

**(B) CLADDED/CEMENTED/LINED PIPES**

S. NO	TYPE OF INSTRUMENTS	WHERE PIPING CLASS SPECIFICS CLADDED PIPES			WHERE PIPING CLASS SPECIFICS CEMENT LINED PIPES			WHERE PIPING CLASS SPECIFICS RUBBER/TEFLON LINED PIPES		
		PROCESS CONNECTION	FIRST BLOCK VALVE	INSTRUMENTS CONNECTION	PROCESS CONNECTION	FIRST BLOCK VALVE	INSTRUMENTS CONNECTION	PROCESS CONNECTION	FIRST BLOCK VALVE	INSTRUMENTS CONNECTION
1	FLOW METER ORIFICE ≤ 600# > 600#	1/2" SCRD* 3/4" SCRD**	1/2" SCRD* 3/4" SW/BW	1/2" SCRD 1/2" SCRD	1/2" SCRD*	1/2" SW/BW	1/2" SCRD	1" FLGD	1/2" SCRD	
2	FLOW METER ORIFICE (DIAPHRAGM. SEAL)	1/2" SCRD* 3/4" SCRD**	1/2" SCRD* 3/4" SCRD*	3" FLGD 3" FLGD	1/2" SCRD* -	1/2" SW/BW	3" FLGD	1" FLGD	3" FLGD	
3	FLOW METER AVERAGE PIVOT TUBE	3" FLGD	3" FLGD (BY INST)	3" FLGD+	3" FLGD	3" FLGD (BY INST)	3" FLGD+	3" FLGD (BY INST)	3" FLGD+	
4	DP INSTRUMENTS	3" FLGD	3/4" SW/BW#	1/2" SCRD.	3" FLGD	3/4" FLGD	1/2" SCRD	1 1/2" FLGD	1/2" SCRD	
5	DIAPHRAGM SEAL D.P. INSTRUMENTS	3" FLGD.	3" FLGD.		3" FLGD	3" FLGD	3" FLGD.	3" FLGD.	3" FLGD.	
6	PRESSURE INSTRUMENTS	3/4" SW/BW#	3/4" SW/BW#	1/2" SCRD.	3" FLGD	3/4" SW/BW	1/2" SCRD	1" FLGD	1/2" SCRD	
7	DIAPHRAGM (CHEMICAL) SEAL PRESSURE INSTRUMENTS (SCRD. ) <5>		3/4" SW/BW#	1/2" SCRD.	3" FLGD	1 1/2" SW/BW	1/2" SCRD	1" FLGD	1/2" SCRD	
8	DIAPHRAGM SEAL PRESSURE INSTRUMENTS (FLGD ) <5>		1 1/2" FLGD.	1 1/2" FLGD.	3" FLGD	1 1/2" FLGD	1 1/2" FLGD	1 1/2" FLGD	1 1/2" FLGD	
9	THERMOWELL	1 1/2" FLGD.	-	1 1/2" FLGD	3" FLGD	-	3" FLGD	-	3" FLGD	

**NOTES:** 1 FOR ANY OTHER INSTRUMENTS NOT REFERRED ABOVE THE CONNECTION DETAILS SHALL BE AS PER INDIVIDUAL REQUIREMENT.

2 ALL FLANGES/SW RATING SHALL BE AS PER PIPING SPECIFICATION.

3 IN CASE OF DIRECT MOUNTED FLANGED INSTRUMENTS AND WHERE FLANGED FIRST ISOLATION VALVE ARE PROVIDED, BOLTING AND GASKETS SHALL BE IN PIPING SCOPE.

4 INSTALLATION OF ALL IN LINE INSTRUMENTS SHALL BE IN PIPING SCOPE.

5 PRESSURE INSTRUMENTS INCLUDE PRESSURE TRANSMITTERS AND PRESSURE GAUGES.

6 INSTRUMENT CONNECTION SIZES/RATINGS AS SPECIFIED BY LICENSOR SHALL HAVE PRECEDENCE OVER SIZES GIVEN IN THIS DOCUMENT.

\* SEAL WELDING REQUIRED.

\*\* STRENGTH WELD

# AS PER PIPING SPECIFICATION.

+ CONNECTIONS FOR D.P. INSTRUMENT 1/2" SCRD



INSTRUMENT  
CONNECTION ON  
(FIRED HEATERS)

S. NO.	TYPE OF INSTRUMENTS	HEATER/DUCT/LINE CONNECTION	FIRST BLOCK VALVE	INSTRUMENT CONNECTION
1	FLOW ELEMENT - AVG. PITOT TUBE (F1)	3" FLANGED	-----	3" FLANGED (NOTE-4)
2	FLOW ELEMENT - VENTURI TUBE (F2)	1/2" FLANGED	1/2" FLANGED	1/2" NPT (F)
3	FLOW ELEMENT - THERMAL MASS (F3)	1 1/2" FLANGED	-----	1 1/2" FLANGED
4	PRESSURE INSTRUMENT (P1)	1 1/2" FLANGED	1 1/2" FLANGED	1/2" NPT (F)
5	PRESSURE INSTRUMENT (COIL) (P2/P4)	1 1/2" FLANGED	1 1/2" FLANGED	1/2" NPT (F)
6	DRAFT GAUGE (P3)	1 1/2" FLANGED	-----	1/2" NPT (F)
7	TEMPERATURE INSTRUMENT (T1)	1 1/2" FLANGED	-----	1 1/2" FLANGED
8	TEMPERATURE INSTRUMENT (COIL) (T2)	1 1/2" FLANGED	-----	1 1/2" FLANGED
9	SKIN THERMOCOUPLE (T3)	1" PIPE	-----	-----
10	FLUE GAS ANALYSER (SOx, NOx, O2, HC, CO) (A1/A2/A4)	4" FLANGED	-----	4" FLANGED
11	FLUE GAS ANALYSER (SPM) (A3)	6" FLANGED	-----	6" FLANGED

NOTES :-

1. PRESSURE RATING OF FLANGE CONNECTION SHALL BE 150# FOR INSTRUMENTS MOUNTED DIRECTLY ON HEATER.
2. PRESSURE RATING OF FLANGE CONNECTION ON TUBE SIDE SHALL BE AS PER PIPING CLASS.
3. FOR IDENTIFICATION (F1), (P1) ETC. REFER TO STANDARDS 7-52-0011, 0012, 0013, 0014.
4. TRANSMITTER CONNECTION SHALL BE 1/2" NPT(F).

3	09-03-12	REVISED & REISSUED	Manoj	ARG	RP/JMS	DM
2	12-03-07	REVISED & REISSUED	MN	TGM	H CJ	VC
Rev. No.	Date	Purpose	Prepared by	Checked by	Stds. Committee Convener	Stds. Bureau Chairman
						Approved by

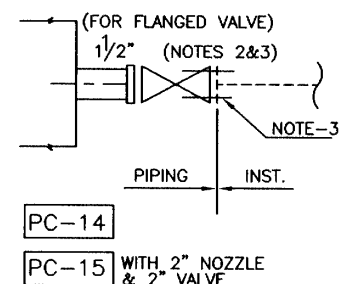
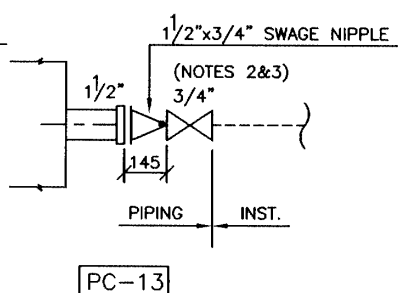
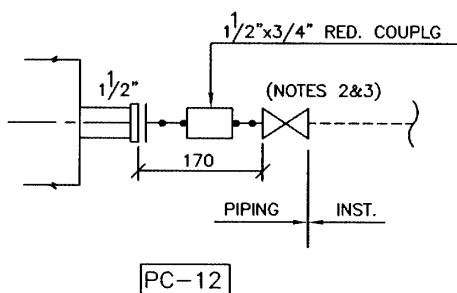
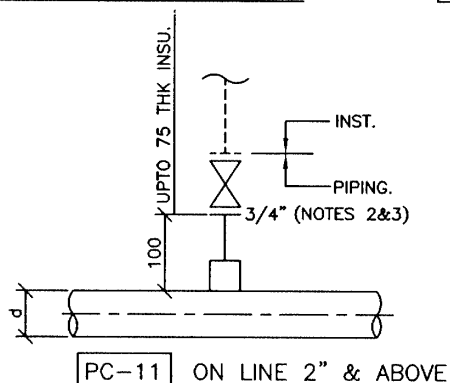
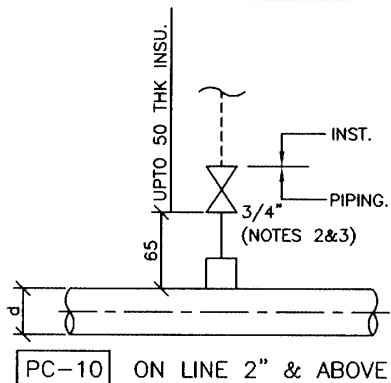
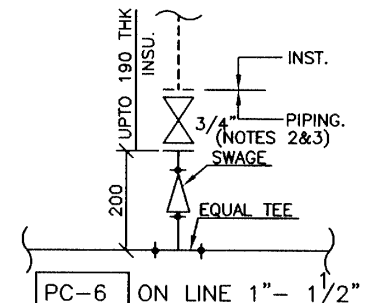
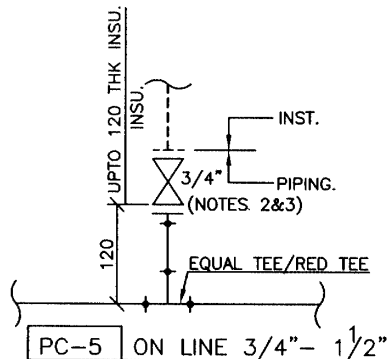
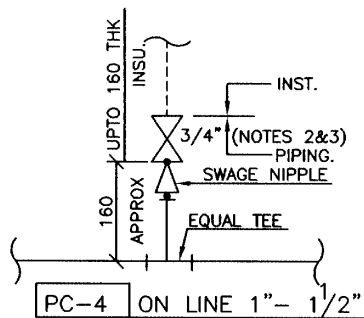
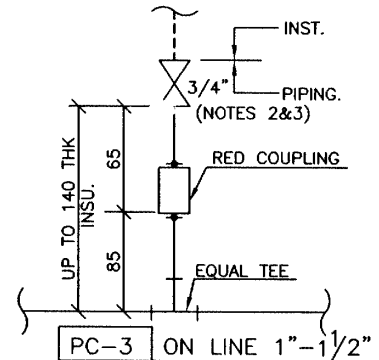
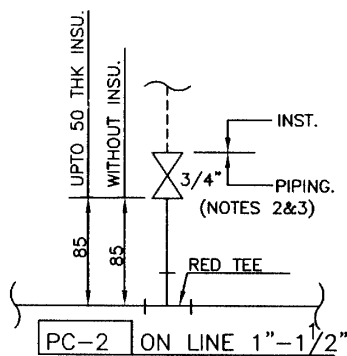
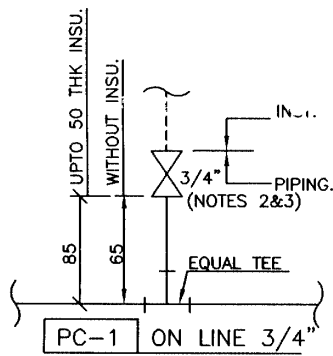

ON VESSELS / COLUMNS

NOTES :

1. THE INDICATED DIMENSIONS ARE MINIMUM WHICH ALSO COVER INSULATION TO THE EXTENT SHOWN ABOVE. IN CASE OF HIGHER THICKNESS OF INSULATION THAN INDICATED THE DIFFERENCE SHALL BE ADDED IN THE DIMENSIONS SHOWN ABOVE.
2. PRESSURE TAPPING SHALL BE PROVIDED WITH VALVE SIMILAR TO LINE ISOLATION VALVE (GATE, BALL OR PLUG VALVE ETC., WITH FLGD, S.W. OR SCR'D ENDS) UNLESS OTHERWISE SPECIFIED IN PMS, TEE(EQUAL OR REDUCING)/HALF COUPLING(S.W. OR SCR'D)/STUB IN/SOCKOLET/WELDOLET SHALL BE AS PER PIPING MATERIAL SPECS.
3. IN CASE OF FLGD VALVES BOLTING & GASKET ON BOTH SIDES OF VALVE SHALL BE IN PIPING SCOPE
4. IN CASE OF TAPPING PROVIDED OTHER THAN INDICATED IN THIS STD FOR LAYOUT REASONS DETAILED DIMENSIONS WILL BE CALLED OUT.

3	29.06.09	REAFFIRMED & ISSUED AS STANDARD	PK	RN	SC	ND
2	15.07.04	REVISED & ISSUED AS STANDARD	RN	SC	MRC	SKG
Rev. No.	Date	Purpose	Prepared by	Checked by	Stds. Committee Convener	Stds. Bureau Chairman
Approved by						

**VENDOR LIST FOR ClO2 GENERATION SYSTEM**

1	HART Communicator	FLUKE CORPORATION/USA
		HONEYWELL INC/PHILADELPHIA
		MERIAM PROCESS TECHNOLOGIES/CLEVELAND, OH 44102
		ABB UTILITY GMBH/GERMANY
		FISCHER ROSEMOUNT ASIA PACIFIC/SINGAPORE
		YOKOGAWA ELECTRIC CORPORATION/TOKYO 180
		FUJII ELECTRIC SYSTEMS CO., LTD./OSAKI 1-CHOME, SHINAGAWA-KU, TOKYO
		YOKOGAWA INDIA LIMITED/BANGALORE
		EMERSON PROCESS MANAGEMENT/KUMARAPARK(WEST), BANGALORE
		CHEMTROLS INDUSTRIES LIMITED/POWAI, MUMBAI
		HONEYWELL AUTOMATION INDIA LTD/PUNE
		GE INDIA INDUSTRIAL PVT. LTD./PUNE
2	Rotameter	INSTRUMENTATION ENGINEERS PVT LTD/JEEDIMATLA
		PLACKA INSTRUMENTS INDIA PVT LTD/CHENNAI
		FLUIDYNE INSTRUMENTS PVT. LTD./CHEMBUR, MUMBAI
		EUREKA INDLEQUIPMENT PVT., LTD./PUNE
3	CABLES - MEDIUM VOLTAGE-POWER-PVC	ASSOCIATED FLEXIBLES AND WIRES [P] LTD INDIA
		CABLE CORPORATION OF INDIA LIMITED INDIA
		FINOLEX CABLES LTD. INDIA
		GEMSCAB INDUSTRIES LTD INDIA
		HAVELL'S INDIA LTD INDIA
		K E I INDUSTRIES LIMITED INDIA
		NICCO CORPORATION LTD INDIA
		POLYCAB WIRES PVT LTD INDIA
		RADIANT CORPORATION PVT LTD INDIA
		RAVIN CABLES LTD INDIA
		RPG CABLES LTD INDIA
		TORRENT CABLES LTD INDIA
UNIVERSAL CABLES LTD INDIA		
4	MOTOR - INDUCTION - MV (INDUSTRIAL TYPE SAFEAREA)	ABB LTD - BANGALORE / FARIDABAD INDIA
		BHARAT BIJLEE LIMITED INDIA
		CROMPTON GREAVES LTD. INDIA
		JYOTI LIMITED INDIA
		KIRLOSKAR ELECTRIC CO LTD INDIA
		LAXMI HYDRAULICS PVT LTD INDIA
		MARATHON ELECTRIC MOTOR I LTD INDIA
SIEMENS LIMITED INDIA		
5	ACTUATOR MOV	AUMA INDIA PRIVATE LTD INDIA
		AUMA RIESTER GMBH & CO. KG GERMANY
		BIFFI ITALIA S.R.L ITALY
		EIM CONTROLS UK LTD UK
		FLO - TORK INC USA
		FLOWSERVE LIMITORQUE INDIA
		LIMITORQUE INDIA LIMITED INDIA
		MARSH ENGINEERS INDIA
ROTORK CONTROLS (INDIA) LTD INDIA		
6	AIR FILTER REGULATORS	IMI NORGREN HERION (P) LTD/NOIDA
		ABB LTD (FARIDABAD) INDIA
		DIVYA CONTROL ELEMENTS PVT LTD INDIA
		JANATICS INDIA PVT LTD INDIA
		MARSH BELLOFRAM INDIA / USA
		PLACKA INSTRUMENTS INDIA P LTD INDIA
		SCHRADER DUNCAN LIMITED INDIA
		SHAH PNEUMATICS INDIA
		SHAVO NORGREN (I) PVT LTD INDIA
		THOMPSON VALVES LTD UK
VELJAN HYDRAIR PVT LTD INDIA		

7	SIGNAL CABLES	ASSOCIATED CABLES PVT LTD INDIA
		ASSOCIATED FLEXIBLES AND WIRES [P] LTD INDIA
		CM I LIMITED INDIA
		CORDS CABLE INDUSTRIES LTD INDIA
		DELTON CABLES LIMITED INDIA
		ELKAY TELELINKS LTD. INDIA
		FINE CORE CABLES PVT LTD INDIA
		GOYOLENE FIBRES (INDIA) PVT LTD INDIA
		K E I INDUSTRIES LIMITED INDIA
		NICCO CORPORATION LTD INDIA
		PARAMOUNT COMMUNICATIONS LIMITED INDIA
		POLYCAB WIRES PVT LTD INDIA
		RADIANT CORPORATION PVT LTD INDIA
		SUYOG ELECTRICALS LTD INDIA
		THERMO CABLES LTD INDIA
		KEC INTERNATIONAL LTD./MUMBAI
		TORRENT CABLES LTD. AHMEDABAD
		ADVANCE CABLE TECHNOLOGIES (P) LTD/BENGALURU
		IMT CABLES PVT LTD/NEW DELHI
		GUPTA POWER INFRASTRUCTURE LTD/BHUBANESHWAR
SPECIAL CABLES PVT LTD/NEW DELHI		
TC COMMUNICATION PVT LTD/ GHAZIABAD		
8	ORIFICE PLATES & FLANGES	BALIGA LIGHTING EQUIPMENTS (P) LIMITED INDIA
		DANIEL MEASURMNT & CONTROL ASIA PACIFIC INDIA / SINGAPORE / USA
		EUREKA INDUSTRIAL EQUIPMENTS (P) LTD. INDIA
		FMC MEASUREMENT SOLUTIONS-UK SINGAPORE / USA / UK
		GENERAL INSTRUMENTS CONSORTIUM INDIA
		GURU NANAK ENGG WORKS INDIA
		INSTRUMENTATION LTD. (PALGHAT) INDIA
		JRU CONTTROL PVT LTD INDIA
		MICRO PRECISION PRODUCTS PVT LTD INDIA
		PETROL VALVES SRL ITALY
		PIETRO FIORENTINI SPA ITALY
		STAR-MECH CONTROLS (INDIA) PVT LTD INDIA
		TM TECNOMATIC SPA ITALY
		9
BAUMER BOURDON HAENNI S.A.S. INDIA / FRANCE		
DAILY THERMETRICS USA		
DETRIV INSTRUMENTATION & ELECTRONICS LTD INDIA		
GAYESCO LLC USA		
GENERAL INSTRUMENTS CONSORTIUM INDIA		
INVENSYS SOFTWARE SYSTEMS (S) PTE LTD INDIA / SINGAPORE		
JAPAN THERMOWELL CO LTD JAPAN		
PYRO-ELECTRIC INSTRUMENTS GOA PVT LTD INDIA		
TEMP-TECH INDIA		
TEMPSEN INSTRUMENT INDIA LTD INDIA		
THERMO ELECTRIC CO. INC. USA		
THERMO-COUPLE PRODUCTS CO INDIA / USA		
THERMO-ELECTRA B.V NETHERLANDS		
TM TECNOMATIC SPA ITALY		
WIKA ALEXANDER WIEGAND & CO GMBH GERMANY		
10	PRESSURE GAUGES	AN INSTRUMENTS PVT LTD INDIA
		ASHCROFT INDIA PVT LTD INDIA
		BADOTHERM PROCESS INSTRUMENTS B.V. NETHERLANDS
		BAUMER BOURDON HAENNI S.A.S. INDIA / FRANCE
		BRITISH ROTOTHERM CO.LTD UK
		BUDENBERG GAUGE CO. LTD UK
		DRESSER INC. USA
		FORBES MARSHALL (HYD) PVT. LTD INDIA
		GENERAL INSTRUMENTS CONSORTIUM INDIA
		GLUCK (INDIA) MFG.CO INDIA
		H GURU INSTRUMENTS(SOUTH INDIA)PVT. LTD INDIA
		H.GURU INDUSTRIES INDIA
		MANOMETER (INDIA) PVT. LTD. INDIA
		NAGANO KEIKI SEISAKUSHO LTD JAPAN
		WAAREE INSTRUMENTS LIMITED INDIA
		WALCHANDNAGAR INDUSTRIES LTD(TIWAC DIVN) INDIA
		WIKA ALEXANDER WIEGAND & CO GMBH GERMANY
		WIKA INSTRUMENTS INDIA PVT LTD INDIA
		BELLS CONTROL LTD/KOLKATA
		BELLS CONTROL LTD/CHENNAI
		PREMIER INSTRUMENTS PVT LTD/COIMBATORE
		PYRO ELECTRIC INSTRUMENTS PVT LTD/GOA
		NEW SCIENTIFIC REPAIRS 7 TRADING CO/KOLKATA
GOA INSTRUMENTS INDUSTRIES PVT LTD/GOA		
ASIAN ENGG & SERVICES/CHENNAI		
LEHRY INSTRUMENTATION & VALVES PVT LTD/ CHENNAI		
KARLO TRADERS/CHENNAI		
VENS HYDROLUFT(P) LTD CHENNAI		

11	TEMP. GAUGES (BI METALLIC , FILLED SYSTEM)	AN INSTRUMENTS PVT LTD INDIA ASHCROFT INDIA PVT LTD INDIA BADOTHERM PROCESS INSTRUMENTS B.V. NETHERLANDS BAUMER BOURDON HAENNI S.A.S. INDIA / FRANCE DRESSER INC. USA GENERAL INSTRUMENTS CONSORTIUM INDIA H GURU INSTRUMENTS(SOUTH INDIA)PVT. LTD INDIA H.GURU INDUSTRIES INDIA NAGANO KEIKI SEISAKUSHO LTD JAPAN PYRO-ELECTRIC INSTRUMENTS GOA PVT LTD INDIA SOLARTRON ISA UK WALCHANDNAGAR INDUSTRIES LTD(TIWAC DIVN) INDIA WIKA ALEXANDER WIEGAND & CO GMBH GERMANY WIKA INSTRUMENTS INDIA PVT LTD INDIA FORBES MARSHALL (HYD) PVT. LTD INDIA
12	VARIABLE AREA FLOW METERS (I, T)	ABB AUTOMATION LTD INDIA / UK ALFLOW GLASS EQUIPMENTS INDIA ASA SPA ITALY EMERSON PROCES MGMT ASIA PACIFIC PTE LTD INDIA / SINGAPORE / USA EUREKA INDUSTRIAL EQUIPMENTS (P) LTD. INDIA HEINRICH MESSTECHNIK GMBH GERMANY INSTRUMENTATION ENGINEERS PVT. LTD. INDIA KROHNE MARSHALL PVT. LTD INDIA KROHNE MESSTECHNIK GMBH & CO KG GERMANY PLACKA INSTRUMENTS INDIA P LTD INDIA ROTA YOKOGAWA GMBH & CO. INDIA / GERMANY TOKYO KEISO CO LTD JAPAN TRANSDUCERS AND CONTROLS PVT LTD INDIA
13	TANK LEVEL IND. (FLOAT OPERATED)	ENDRESS+HAUSER JAPAN CO. LTD INDIA / JAPAN ENRAF B.V INDIA / NETHERLAND L & J TECHNOLOGIES SINGAPORE / USA NIVO CONTROLS PVT LTD INDIA SBEM PVT LTD INDIA SIGMA INSTRUMENTS CO INDIA TOKYO KEISO CO LTD JAPAN BAUMER TECHNOLOGIES INDIA PVT LTD/CHENNAI PUNE TECHTROL PVT LTD/CHENNAI V AUTOMAT AND INSTRUMENTS LTD/CHENNAI
14	TRANSDUCERS (I/P , P/I)	ABB LTD (FARIDABAD) INDIA ABB AUTOMATION LTD INDIA / UK EMERSON PROCES MGMT ASIA PACIFIC PTE LTD INDIA / SINGAPORE / USA EMERSON PROCESS MANAGEMENT INDIA PVT LTD INDIA FAIRCHILD INDUSTRIAL PRODUCTS CO. INDIA / USA IMI WATSON SMITH LTD UK MOORE CONTROLS LTD INDIA MTL INDIA INDIA SHREYAS INSTRUMENTS PVT LTD INDIA THERMO BRANDT INSTRUMENTS USA
15	SOLENOID VALVES	ALCON ALEXANDER CONTROLS LIMITED UK ASCO (INDIA) LIMITED INDIA ASCO JOUCOMATIC LTD INDIA / UK ASCO JOUCOMATIC SA FRANCE AVCON CONTROLS PVT. LTD. INDIA HERION WERKE GERMANY PRECISION INSTRUMENT COMPANY INDIA ROTEX AUTOMATION LTD. INDIA SCHRADER DUNCAN LIMITED INDIA THOMPSON VALVES LTD UK VERSA BV NETHERLANDS

16	WATER QUALITY ANALYSER - PH	ABB LTD (FARIDABAD) INDIA ABB AUTOMATION LTD INDIA / UK EMERSON PROCES MGMT ASIA PACIFIC PTE LTD INDIA / SINGAPORE / USA EMERSON PROCESS MANAGEMENT INDIA PVT LTD INDIA ENDRESS + HAUSER INSTRUMNTS INTL. AG INDIA / GERMANY ENDRESS+HAUSER (I) PVT. LTD. INDIA FORBES POLYMETRON PVT LTD. INDIA HONEYWELL AUTOMATION INDIA LTD INDIA HONEYWELL INC. INDIA / USA INVENSYS INDIA PRIVATE LIMITED INDIA INVENSYS SOFTWARE SYSTEMS (S) PTE LTD INDIA / SINGAPORE /USA SERES ENVIRONMENT (FORM. SERES) FRANCE YOKOGAWA ELECTRIC CORPORATION INDIA / JAPAN YOKOGAWA INDIA LIMITED INDIA
17	WATER QUALITY ANALYSER - CONDUCTIVITY	ABB LTD (FARIDABAD) INDIA ABB AUTOMATION LTD INDIA / UK EMERSON PROCES MGMT ASIA PACIFIC PTE LTD INDIA / SINGAPORE / USA EMERSON PROCESS MANAGEMENT INDIA PVT LTD INDIA ENDRESS + HAUSER INSTRUMNTS INTL. AG INDIA / GERMANY ENDRESS+HAUSER (I) PVT. LTD. INDIA FORBES POLYMETRON PVT LTD. INDIA HONEYWELL AUTOMATION INDIA LTD INDIA HONEYWELL INC. INDIA / USA INVENSYS INDIA PRIVATE LIMITED INDIA INVENSYS SOFTWARE SYSTEMS (S) PTE LTD INDIA / SINGAPORE / USA YOKOGAWA ELECTRIC CORPORATION INDIA / JAPAN YOKOGAWA INDIA LIMITED INDIA
18	SPL. LEVEL INSTRUMENTS - GUIDED WAVE RADAR	EMERSON PROCESS MANAGEMENT INDIA PVT LTD INDIA ENDRESS + HAUSER INSTRUMNTS INTL. AG INDIA / GERMANY K-TEK CORPORATION INDIA / USA KROHNE MESSTECHNIK GMBH & CO KG GERMANY L & J TECHNOLOGIES SINGAPORE / USA MAGNETROL INTERNATIONAL N.V INDIA / BELGIUM TOKYO KEISO CO LTD JAPAN
19	TANK LEVEL INSTRUMENT (RADAR , ULTRASONIC )	AMETEK DREXELBROOK USA EMERSON PROCESS MANAGEMENT INDIA PVT LTD INDIA / SINGAPORE / USA ENDRESS + HAUSER INSTRUMNTS INTL. AG INDIA / GERMANY ENRAF B.V INDIA / NETHERLAND HAWK MEASUREMENT SYSTEM PTY LTD AUSTRALIA KROHNE MESSTECHNIK GMBH & CO KG GERMANY L & J TECHNOLOGIES SINGAPORE / USA MAGNETROL INTERNATIONAL N.V INDIA / BELGIUM MOBREY LTD INDIA / UK ROSEMOUNT TANK RADAR AB SWEDEN SIEMENS AG INDIA / GERMANY VEGA GRIESHABER KG GMBH GERMANY
20	DIFFERENTIAL PRESSURE GAUGES	AN INSTRUMENTS PVT LTD INDIA FORBES MARSHALL (HYD) PVT. LTD INDIA GENERAL INSTRUMENTS CONSORTIUM INDIA HIRLEKAR PRECISION ENGINEERING PVT LTD INDIA SAMSON CONTROLS PVT LTD INDIA SWITZER INSTRUMENT LTD INDIA WAAREE INSTRUMENTS LIMITED INDIA WIKI INSTRUMENTS INDIA PVT LTD INDIA
21	FIELD INSTRUMENTS (P,DP,F,L,T,TD)	ABB LTD (FARIDABAD) INDIA ABB AUTOMATION LTD INDIA / UK EMERSON PROCES MGMT ASIA PACIFIC PTE LTD INDIA / SINGAPORE / USA EMERSON PROCESS MANAGEMENT INDIA PVT LTD INDIA FUJI ELECTRIC SYSTEMS CO. LTD INDIA / JAPAN HONEYWELL AUTOMATION INDIA LTD INDIA HONEYWELL INC. INDIA / USA YOKOGAWA ELECTRIC CORPORATION INDIA / JAPAN YOKOGAWA INDIA LIMITED INDIA

22	TUBE FITTINGS	ARYA CRAFTS & ENGINEERING PVT LTD INDIA
		ASTEC VALVES & FITTINGS PVT. LTD. INDIA
		AURA INC. INDIA
		AUTOCLAVE ENGINEERS FLUID COMPONENTS USA
		BADOTHERM PROCESS INSTRUMENTS B.V. NETHERLANDS
		CIRCOR INSTRUMENTATION LTD UK
		EXCEL HYDRO PNEUMATICS PVT LTD INDIA
		EXCELSIOR ENGG. WORKS INDIA
		FLUID CONTROLS PVT LTD INDIA
		HAM-LET (ISRAEL-CANADA) LTD. ISRAEL
		JRU CONTTROL PVT LTD INDIA
		MULTIMETAL INDUSTRIES INDIA
		PANAM ENGINEERS INDIA
		PARKER HANNIFIN CORPORATION INDIA / UK / USA
		PRECISION ENGINEERING INDUSTRIES INDIA
		PRIME ENGINEERS INDIA
		RELIANCE ENGINEERING & ELECTRICALS CORPN INDIA
SWAGELOK CO. INDIA / USA		
SWASTIK ENGINEERING WORKS INDIA		
23	INSTRUMENT TUBING	HEAVY METALS & TUBES LIMITED(MEHSANA) INDIA
		JINDAL SAW LTD (NASHIK WORKS) INDIA
		NUCLEAR FUEL COMPLEX INDIA
		RAJENDRA MECH INDUSTRIES LTD INDIA
		RATNAMANI METALS AND TUBES LTD INDIA
SANDVIK ASIA LIMITED (AHMEDABAD) INDIA		
24	LEVEL SWITCHES (DISPLACER /FLOAT)	BLISS ANAND PVT LTD INDIA
		CHEMTROLS INDUSTRIES LTD INDIA
		DAG PROCESS INSTRUMENTS PVT LTD INDIA
		EMERSON PROCES MGMT ASIA PACIFIC PTE LTD INDIA / SINGAPORE /USA
		ENDRESS+HAUSER JAPAN CO. LTD INDIA / JAPAN
		JRU CONTTROL PVT LTD INDIA
		KROHNE MESSTECHNIK GMBH & CO KG GERMANY
		KSR KUEBLER NIVEAUMESS-TECHNIK AG GERMANY
		LEVCON INSTRUMENTS PVT LTD INDIA
		MAGNETROL INTERNATIONAL N.V INDIA / BELGIUM
		MOBREY LTD INDIA / UK
		SBEM PVT LTD INDIA
		SIGMA INSTRUMENTS CO INDIA
		SOR INC. USA
TOKYO KEISO CO LTD JAPAN		
TRANSDUCERS AND CONTROLS PVT LTD INDIA		
V AUTOMAT & INSTRUMENTS PVT LTD INDIA		
25	PRESSURE SWITCHES	ASCO JOUCOMATIC LTD INDIA / UK
		BAUMER BOURDON HAENNI S.A.S. INDIA / FRANCE
		BETA BV NETHERLANDS
		DAG PROCESS INSTRUMENTS PVT LTD INDIA
		DELTA CONTROLS LTD UK
		DRESSER INC. USA
		GENERAL INSTRUMENTS CONSORTIUM INDIA
		INFOS INDUSTRIES LIMITED INDIA
		NAGANO KEIKI SEISAKUSHO LTD JAPAN
		PYROPRESS ENGG CO LTD UK
		REGULATEURS GEORGIN S.A FRANCE
		ROBERTSHAW CONTROLS CO USA
		SIRCO CONTROLS LIMITED UK
		SOR INC. USA
SWITZER INSTRUMENT LTD INDIA		
UNITED ELECTRIC CONTROLS CO USA		
26	ANALYSER SYSTEM	ABB AUTOMATION LTD INDIA / UK
		ABB LTD-BANGALORE INDIA
		CHEMTROLS INDUSTRIES LTD INDIA
		EMERSON PROCES MGMT ASIA PACIFIC PTE LTD INDIA / SINGAPORE /USA
		EMERSON PROCESS MANAGEMENT INDIA PVT LTD INDIA
		HAMILTON SUNDSTRAND CORPORATION USA
		SERVOMEX PLC INDIA / UK
		SIEMENS AG INDIA / GERMANY
		TELEDYNE ANALYTICAL INSTRUMENTS USA
		YOKOGAWA ELECTRIC CORPORATION INDIA / JAPAN
YOKOGAWA INDIA LIMITED INDIA		

27	INSTRUMENT VALVES& MANIFOLDS	ANDERSON GREENWOOD CROSBY INDIA / USA ARYA CRAFTS & ENGINEERING PVT LTD INDIA ASTECH VALVES & FITTINGS PVT. LTD. INDIA AURA INC. INDIA AUTOCLAVE ENGINEERS FLUID COMPONENTS USA CHEMTROLS INDUSTRIES LTD INDIA CIRCOR INSTRUMENTATION LTD UK EXCEL HYDRO PNEUMATICS PVT LTD INDIA EXCELSIOR ENGG. WORKS INDIA HAM-LET (ISRAEL-CANADA) LTD. ISRAEL HYD-AIR ENGG. WORKS LONAVLA INDIA MICRO PRECISION PRODUCTS PVT LTD INDIA PANAM ENGINEERS INDIA PARKER HANNIFIN CORPORATION INDIA / UK / USA PRECISION ENGINEERING INDUSTRIES INDIA PRIME ENGINEERS INDIA SWAGELOK CO. INDIA / USA SWASTIK ENGINEERING WORKS INDIA TECNOMATIC INDIA PVT LTD INDIA
28	WATER QUALITY ANALYSER-DISSOLVED OXYGEN	ABB LTD (FARIDABAD) INDIA ABB AUTOMATION LTD INDIA / UK EMERSON PROCES MGMT ASIA PACIFIC PTE LTD INDIA / SINGAPORE /USA EMERSON PROCESS MANAGEMENT INDIA PVT LTD INDIA ENDRESS + HAUSER INSTRUMNTS INTL. AG INDIA / GERMANY FORBES POLYMETRON PVT LTD INDIA HONEYWELL AUTOMATION INDIA LTD INDIA HONEYWELL INC. INDIA / USA INVENSYS SOFTWARE SYSTEMS (S) PTE LTD INDIA / SINGAPORE /USA YOKOGAWA ELECTRIC CORPORATION INDIA / JAPAN YOKOGAWA INDIA LIMITED INDIA
29	WATER QUALITY ANALYSER SYSTEMS	ABB LTD (FARIDABAD) INDIA ABB AUTOMATION LTD INDIA / UK EMERSON PROCES MGMT ASIA PACIFIC PTE LTD INDIA / SINGAPORE /USA EMERSON PROCESS MANAGEMENT INDIA PVT LTD INDIA ENDRESS + HAUSER INSTRUMNTS INTL. AG INDIA / GERMANY FORBES POLYMETRON PVT LTD. INDIA HONEYWELL AUTOMATION INDIA LTD INDIA HONEYWELL INC INDIA / USA SERES ENVIRONMENT (FORM. SERES) FRANCE YOKOGAWA ELECTRIC CORPORATION INDIA / JAPAN YOKOGAWA INDIA LIMITED INDIA
30	WATER QUALITY ANALYSERS (TURBIDITY)	ABB LTD (FARIDABAD) INDIA ABB AUTOMATION LTD INDIA / UK EMERSON PROCES MGMT ASIA PACIFIC PTE LTD INDIA / SINGAPORE /USA EMERSON PROCESS MANAGEMENT INDIA PVT LTD INDIA ENDRESS + HAUSER INSTRUMNTS INTL. AG INDIA / GERMANY FORBES POLYMETRON PVT LTD. INDIA SERES ENVIRONMENT (FORM. SERES) FRANCE YOKOGAWA ELECTRIC CORPORATION INDIA / JAPAN YOKOGAWA INDIA LIMITED INDIA
31	WATER QUALITY ANALYSERS(CHLORINE)	ABB LTD (FARIDABAD) INDIA ABB AUTOMATION LTD INDIA / UK EMERSON PROCES MGMT ASIA PACIFIC PTE LTD INDIA / SINGAPORE /USA EMERSON PROCESS MANAGEMENT INDIA PVT LTD INDIA ENDRESS + HAUSER INSTRUMNTS INTL. AG INDIA / GERMANY SERES ENVIRONMENT (FORM. SERES) FRANCE YOKOGAWA ELECTRIC CORPORATION INDIA / JAPAN YOKOGAWA INDIA LIMITED INDIA
32	MAGNETIC FLOW METERS	ABB AUTOMATION LTD INDIA / UK EMERSON PROCES MGMT ASIA PACIFIC PTE LTD INDIA / SINGAPORE /USA EMERSON PROCESS MANAGEMENT INDIA PVT LTD INDIA ENDRESS + HAUSER INSTRUMNTS INTL. AG INDIA / GERMANY ENDRESS+HAUSER (I) PVT. LTD. INDIA HEINRICHS MESSSTECHNIK GMBH GERMANY INSTRUMENTATION ENGINEERS PVT. LTD. INDIA INVENSYS SOFTWARE SYSTEMS (S) PTE LTD INDIA / SINGAPORE /USA KROHNE MARSHALL PVT. LTD INDIA KROHNE MESSSTECHNIK GMBH & CO KG GERMANY TOKYO KEISO CO LTD JAPAN YAMATAKE CORPORATION LTD JAPAN YOKOGAWA ELECTRIC CORPORATION INDIA / JAPAN YOKOGAWA INDIA LIMITED INDIA

33	A.C. (MV) VARIABLE SPEED DRIVE	ABB LTD (BANGALORE) INDIA ASEA BROWN BOVERY LIMITED SWITZERLAND BALDOR ELECTRIC COMPANY INDIA / USA BHEL (BANGALORE) INDIA DANFOSS INDUSTRIES PVT LTD INDIA EUROTHERM DEL INDIA LIMITED INDIA FUJI ELECTRIC CO LTD JAPAN HITACHI LTD INDIA / JAPAN KIRLOSKAR ELECTRIC CO LTD INDIA LARSEN & TOUBRO LTD INDIA MEIDENSHA CORP JAPAN ROCKWELL AUTOMATION INDIA LTD INDIA SCHNEIDER ELECTRIC INDIA PVT LTD INDIA SIEMENS AG INDIA / GERMANY SIEMENS LIMITED INDIA SIEMENS-ALLIS ENERGY PRODUCTS INDIA / GERMANY TOSHIBA CORPORATION INDIA / JAPAN VACON OYJ INDIA / FINLAND
34	CABLE TRAYS (LADDER TYPE) & WITH COVER & PERFRATD	CAUVERY ENGINEERING WORKS/PUDUKKOTTAI M METAPRINT INDUSTRIES/CHENNAI PATNY SYSTEMS (P) LTD./SECUNDERABAD PRAMMEN INDUSTRIES/PUDUKOTTAI AM-TECH ENGINEERING SERVICES/PUNE JAMNA METAL COMPANY/DELHI JAMUNA METAL COMPANY/SONEPAT (DT ) KANADE ANAND UDYOG PVT. LTD/MUMBAI INAR PROFILES PVT. LIMITED/ANAKAPALLE INDUSTRIAL PERFORATION (INDIA) PVT. LTD/KOLKATA PREMIER POWER PRODUCTS (CALCUTTA) PVT. LTD/KOLKATA PARMAR METALS PVT LTD/RAJKOT RATAN PROJECTS & ENGINEERING CO PVT. LTD/KOLKATA RUKMANI ELECTRICAL & COMPONENTS PRIVATE LTD/KOLKATA SILVERLINE POWER INFRASTRUCTURE PVT LTD/VADODARA
35	JUNCTION BOX FOR POWER & INSTRUMENTS	TECH-UP ENGINEERING PVT. LTD/TIRUCHIRAPPALLI SHIBSHA INSTRUMENT INDIA P LTD/CHENNAI WIN POWER/KOLKATA CHEMIN CONTROLS AND INSTRUMENTATION PVT. LTD/PONIDICHERRY PYROTECH ELECTRONICS PVT LTD/UDAIPUR SAHYADRI ELECTRO CONTROLS (INDIA) PRIVATE LTD./BENGALURU SRI VISHNU INDUSTRIES/HOSUR KEAS CONTROL SYSTEMS INDIA PRIVATE LIMITED/COIMBATORE BALAJI ELECTROCONTROLS PVT. LTD./BENGALURU HAROLD INDUSTRIES PVT LTD./CHENNAI K.S.INSTRUMENTS PVT. LTD./BENGALURU AXON TECHNOLOGIES/KANCHEPURAM DIST MAIKA METALS PVT LTD/CHENNAI PRAMMEN INDUSTRIES/PUDUKOTTAI SAJAS ELECTRICALS/TIRUCHIRAPPALLI
36	PADDLE WHEEL FLOW TRANSMITTER	BURKERT CONTROMATIC PVT LTD/CHENNAI GEORG FISCHER PIPING SYSTEMS PVT LTD/CHENNAI
37	GAS DETECTION SYSTEM	CHEMTROLS INDUSTRIES LTD INDIA CROWCON DETECTION INSTRUMENTS LTD UK DETECTION INSTRUMENTS (I) PVT. LTD. INDIA DETECTOR ELECTRONICS CORP.(KIDDE CO.) INDIA / USA DRAGER SAFETY AG & CO. KGAA INDIA/ GERMANY GENERAL MONITORS IRELAND LTD UK HONEYWELL ANALYTICS INDIA / UK INDUSTRIAL SCIENTIFIC OLDHAM FRANCE MINE SAFETY APPLIANCES COMPANY USA MSA (INDIA) LTD INDIA
38	ANALYSER-DENSITY/SP. GRAVITY (NUCLEONIC)	BERTHOLD TECHNOLOGIES GMBH & CO.KG GERMANY ENDRESS + HAUSER INSTRUMNTS INTL. AG INDIA / GERMANY ENDRESS+HAUSER (I) PVT. LTD. INDIA OHMART/VEGA CORPORATION USA RONAN ENGINEERING COMPANY USA THERMO FISHER SCIENTIFIC INDIA / USA
39	ANALYSER-DENSITY/SP. GRAVITY (VIB CYLINDER)	BOPP & REUTHER MESSTECHNIK GMBH GERMANY EMERSON PROCESS MANAGEMENT INDIA PVT LTD INDIA MOBREY LTD INDIA / UK THERMO FISHER SCIENTIFIC INDIA / USA
40	PRODUCT QUALITY ANALYSERS (DENSITY)	BOPP & REUTHER MESSTECHNIK GMBH GERMANY MOBREY LTD INDIA / UK THERMO FISHER SCIENTIFIC INDIA / USA



**SPECIFICATION FOR  
LT MOTORS (AC)**

**SPECIFICATION NO: ROS-4079**

**REV.No.: 00**

**BHARAT HEAVY ELECTRICALS LIMITED,  
RANIPET- 632 406.**

**TECHNICAL SPECIFICATION**

**For**

**LT MOTORS (AC)**

00	07.12.13	RPS/MKV	VNS	SK	Fresh issue
Rev.No	Date	Prepared	Checked	Approved	Remarks

	<b>SPECIFICATION FOR LT MOTORS (AC)</b>	<b>SPECIFICATION NO: ROS-4079</b>
		<b>REV.No.: 00</b>

**SCOPE OF SUPPLY:**

Supply of LT Motors as per enclosed **EIL specification: 6-51-0032- Rev 04**(14 pages). Vendors to meet applicable clauses of this specification in toto for the subject enquiry.

**SITE DATA:**

Ambient Temperature : 50 Deg.C  
Humidity : 89% RH at 45 Dec.C  
Location : Outdoor / Indoor, Non-Air Conditioned  
Atmospheric condition : Dusty & Polluted  
Classification of Area : Non Hazardous Area  
Seismic zone : Zone III (As per IS 1893)

**SPARES:**

1. COMMISSIONING SPARES:

Vendor to include the required commissioning spares with the motor main supply.

2. MANDATORY SPARES:

1. 1 NO OF EACH TYPE OF BEARINGS SET FOR DE & NDE
2. 1 SET FOR EACH TYPE OF STUD / BUSHING ASSEMBLY.

3. RECOMMENDED SPARES:

Vendor to furnish a list of recommended spares for two years operation along with item wise price.

**DATA SHEET:**

Vendor shall submit the Motor data sheet as per enclosed data sheet format vide ref: 6987-017-16-50-DS-08 Rev.0(2 pages)

	<b>SPECIFICATION FOR LT MOTORS (AC)</b>	<b>SPECIFICATION NO: ROS-4079</b>
		<b>REV.No.: 00</b>

**VENDOR LIST:**

1. ABB LIMITED
2. BHARAT BIJLEE LIMITED
3. CROMPTON GREAVES LIMITED
4. JYOTI LIMITED
5. KIRLOSKAR ELECTRIC CO LTD
6. LAXMI HYDRAULICS PVT LTD
7. MARATHON ELECTRIC MOTOR I LTD
8. SIEMENS LIMITED.

\*\*\*\*\*