

BHARAT HEAVY ELECTRICALS LIMITED
IVP GOINDWAL SAHIB
MM DEPARTMENT

Expression of Interest: BV:EOI:01:2013-14 dated 07.10.2013

BHEL, Industrial Valves Plant (IVP) invites Expression of Interest from interested Ball manufactures for supplying of Balls as per below table.

Interested Suppliers may fill the supplier information and attach the relevant documents and send to us.

Engineer/MM
BHEL,IVP,
433, Industrial Complex,
Goindwal Sahib
Distt Tarn- Taran
Punjab-143422

BHEL, IVP Goindwal is also asking for budgetary quotation for these two items. Budgetary quotation format is attached.

Item:	Mat Code	Drg No
Ball - 8" - C300 Floating Type	964655430000	3VBA5125221
Ball- BA01	964655460000	3VBA0125069

Initial quantity of these balls will be 5 to 10 Nos each.

Supplier Information:

Name of Organization with address	
Contact Person and number	
Turn over (2011-12) (2012-13)	
Previous Purchase Order Copies for similar type of product	<u>Attach the PO copies</u>
Existing Size Range	
Present Reputed Customers	

3-V-BA01-25069

DRAWING NO.

3.2 / 1.6 / 0.1

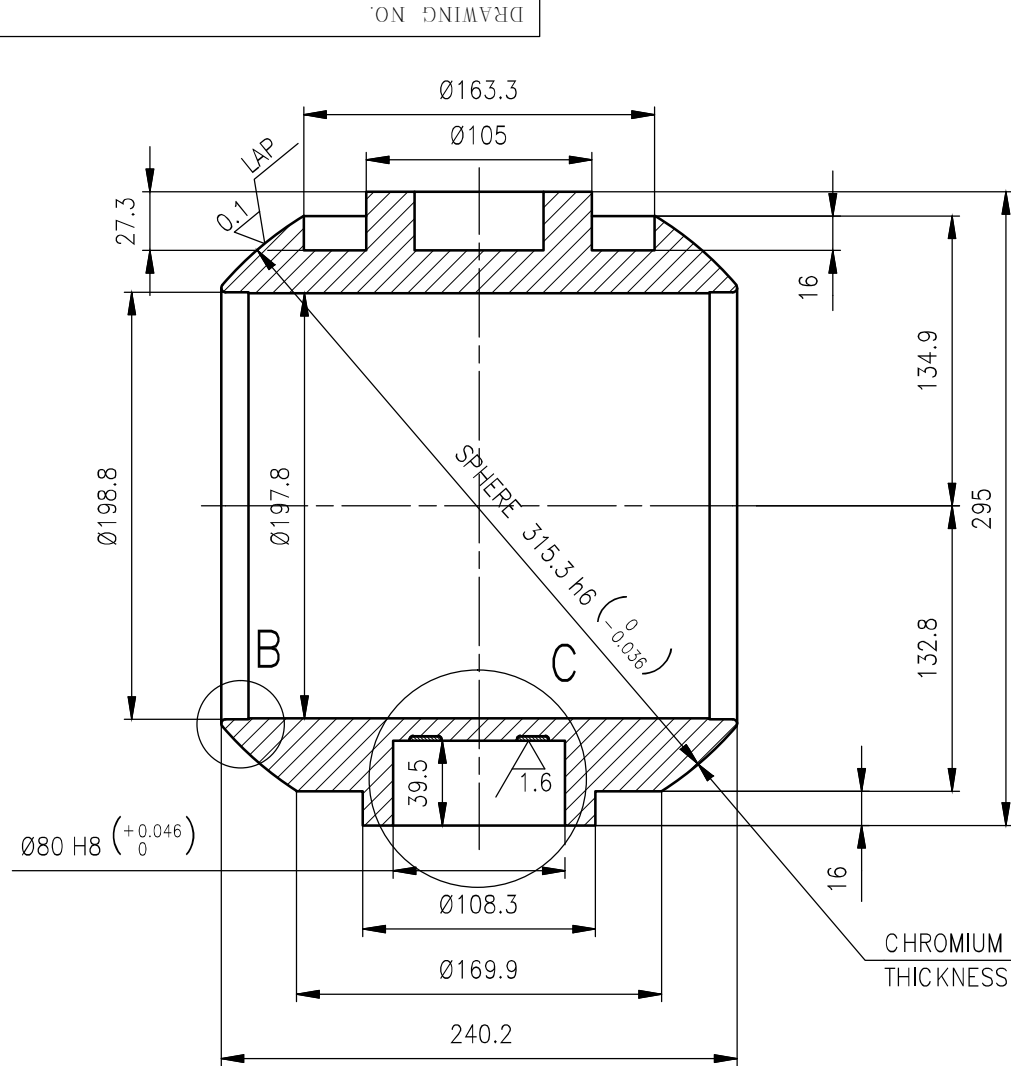

SECTION A-A

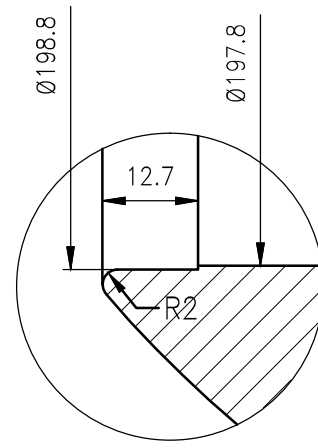

DETAIL-B

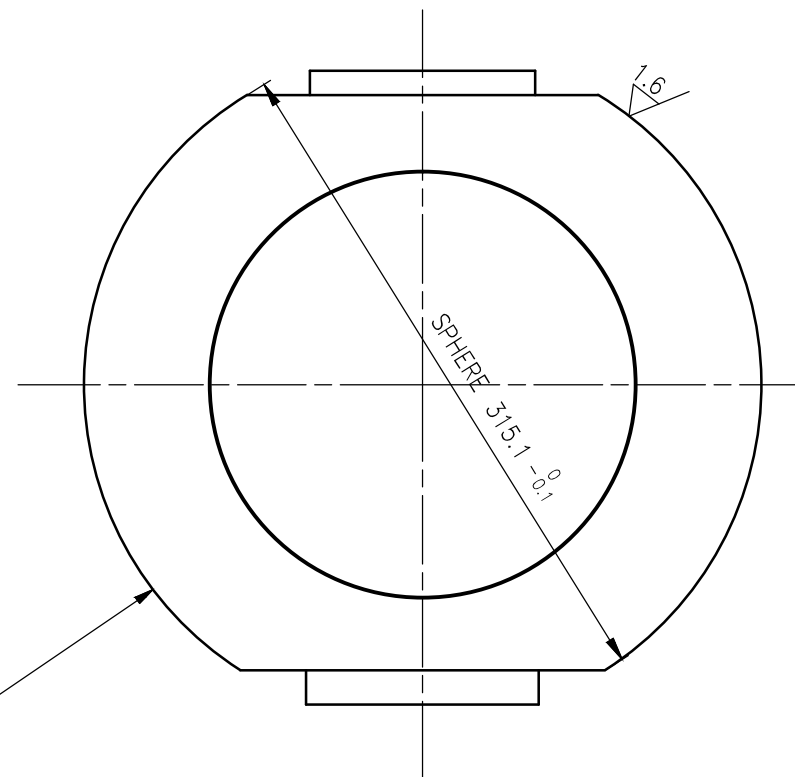

ROUGH MACHINED

CHROMIUM CARBIDE COATING
THICKNESS 0.2mm MIN.(ENTIRE SURFACE)

CHROMIUM CARBIDE COATING
THICKNESS 0.1mm MIN.(ENTIRE SURFACE)

NOTES:

1. BEFORE LAPPING ALL SHARP EDGES TO BE RADIUSED TO R0.3 MAX.
2. CHECK SURFACE FINISH AND LAP FACES, IF NECESSARY.
3. CONDUCT LPI ON CHROMIUM CARBIDE SURFACE AFTER FINAL MACHINE.
4. CHROMIUM CARBIDE COATING THICKNESS 0.2mm MIN. TO BE MAINTAINED.
5. CHROMIUM CARBIDE SURFACE HARDNESS 55 HRC MIN.
6. COAT: INDOOR RUST PREVENTIVE COATING.

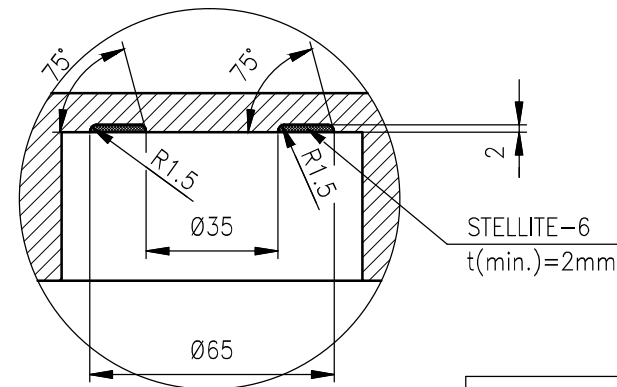
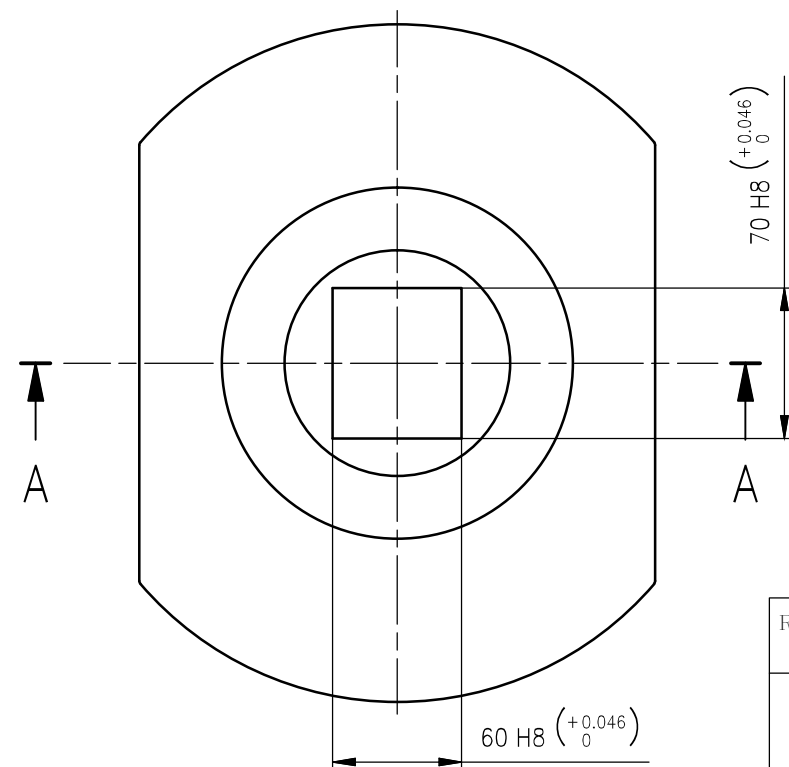

DETAIL-C

CAUTION: The information on this document is the property of BHARAT HEAVY ELECTRICALS LTD. It must not be used directly or indirectly in any way detrimental to the interest of the company.

01	-	-	ASTM A182 F316, PRODUCT ATTEST	SH	-	56.1	-	3-V-BA01-25059	04
VO C/F	DESCRIPTION	VAT. CODE	VAT. SPECIF.	HAI TREATMENT	SCRAP SORT	NET WT (KG)	GROSS WT (KG)	DRAWING No	ITEM No

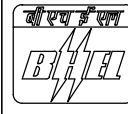
TYPE OF PRODUCT OR NAME OF CUSTOMER/PROJECT		BALL VALVE								
 BHARAT HEAVY ELECTRICALS LTD., UNIT: HIGH PRESSURE BOILER PLANT, TIRUCHIRAPALLI-620014.		DRN	NAME	SIGN	DATE	NO. OF VAR.				
		CHD	K.RAJASEKARAN		01.01.13					
		APPD	SAKETH							
DEPT	VL	SCALE	WEIGHT (KG)	REFERENCE INFORMATION			NO. OF ITEMS			
320		NTS	56.1	MATL. CODE: 964655460000						
TITLE			CARD CODE	DRAWING NO.			REV			
BALL (8"-C300)			U 01	3-V-BA01-25069						

REV	DATE	ALTERED
		CHD & APPD