

REQUEST FOR QUOTATION

	BHARAT HEAVY ELECTRICALS LIMITED Electronics Division PB No. 2606, Mysore Road Bangalore - 560026 INDIA	RFQ NUMBER: NSHM900017 RFQ DATE : 19.AUG.2008	Due Date 22.SEP.2008 Time: 13:00 HRS VENUE : NEW ENGG. BLDG
MMI:PU:RF:003			

	(for all correspondence) Purchase Executive : NEELIMA S Phone : 00918026998609 Fax : 00918026740138 E-mail: neelima@bheledn.co.in
--	-----------------------------------------------------------------------------------------------------------------------------------------------

Please submit your lowest quotation subject to our terms and conditions attached for the material mentioned below. The quotation must be enclosed in a sealed envelope / Fax superscribed with RFQ no.and due date, should reach us on or before the due date by **13.00** hours IST and will be opened on the same day

1. TENDER / OFFER SHALL BE SUBMITTED IN TWO PARTS.
2. QUOTATIONS MAY BE SUBMITTED BY OEM OR THEIR AUTHORISED DEALERS.
3. VENDOR IS EXPECTED TO HAVE ESTABLISHED SALES,SERVICE AND SUPPORT NETWORK PREFERABLY, IN INDIA. A LIST OF THE SAME NEEDS TO BE ENCLOSED WITH THE OFFER.
4. A LIST OF REFERENCES INCLUDING CUTSTOMER#S DETAILS LIKE CONTACT, MACHINES INSTALLED, DATE OF INSTALLATION IN INDIA AND ABROAD SHALL BE SUBMITTED THAT ESTABLISHES THE SATISFACTORY PERFORMANCE OF SUPPLIER#S EQUIPMENT FOR AT LEAST THREE YEARS.
5. VENDOR IS ADVISED TO GO THROUGH THE GENERAL TERMS AND CONDITIONS **DOCUMENT CPD-00** ENCLOSED WITH RFQ.
6. BHEL RESERVES THE RIGHT TO RESORT TO REVERSE AUCTION BEFORE THE PRICE BID OPENING.
7. VENDOR HAS TO CONFORM TO ALL THE CLAUSES LISTED IN THE TECHNO-COMMERCIAL TERMS (ANNEXURE-B OF **DOCUMENT CPD-00**), DEVIATIONS, IF ANY, TO BE HIGHLIGHTED AND BROUGHT OUT CLEARLY.
8. VENDOR HAS TO CONFORM TO ALL THE CLAUSES IN THE PURCHASE SPECIFICATIONS.
9. DELIVERY REQUIRED: WITHIN 12 WEEKS FROM THE DATE OF PURCHASE ORDER.
10. TERMS OF PAYMENT: 75% ON RECEIPT OF MATERIAL, 15% AFTER INSTALLATION AND COMMISSIONING AND THE REST 10% AGAINST SUBMISSION OF PBG.

Sl No.	Description	Qty	Unit	Delivery qty	Delivery Date
1	CU9095003659 GATE DRIVER EVALUATION FACILITY AS PER PS/445/057	1	NO	1	09.DEC.2008

Total Number of Items - 1

Please note that the tender will be opened in the presence of the bidders or his authorised representatives (maximum two per organisation) who choose to be present with authorisation letters. Refer annexure for the terms and conditions.

Preference will be given to vendors who accepts our standard payment terms i.e.100% payment - 30 days after receipt of material at our works subject to acceptance.

Please specify Terms of delivery, Excise duty, sales tax, Ex-BHEL, Ex-works surcharge, Insurance,P&F, Freight and other taxes very clearly .

- i).This is only RFQ not an order.
- ii).In all correspondence quote RFQ No. & due date.
- iii).In Quotation BHEL material code / RFQ Sl. No. should be mentioned clearly.
- iv).Quotation Envelope / Fax not superscribed with RFQ No.and due date is liable for rejection.
- v).Quotation should remain valid for a minimum peiod of 90 days from due date.
- vi).In case of non-receipt of Quotation or regret letter for 3 consecutive RFQs you are liable to be removed from our

For and On behalf of BHEL.

REQUEST FOR QUOTATION

	BHARAT HEAVY ELECTRICALS LIMITED Electronics Division PB No. 2606, Mysore Road Bangalore - 560026 INDIA	RFQ NUMBER: NSHM900017 RFQ DATE : 19.AUG.2008	Due Date 22.SEP.2008 Time: 13:00 HRS VENUE : NEW ENGG. BLDG		
MMI:PU:RF:003		(for all correspondence) Purchase Executive : NEELIMA S Phone : 00918026998609 Fax : 00918026740138 E-mail: neelima@bheledn.co.in			
Please submit your lowest quotation subject to our terms and conditions attached for the material mentioned below. The quotation must be enclosed in a sealed envelope / Fax superscribed with RFQ no.and due date, should reach us on or before the due date by 13.00 hours IST and will be opened on the same day					
SI No.	Description	Qty	Unit	Delivery qty	Delivery Date
vendors list.					
vii). All Prices should be written in words and numbers.					
viii). Excise Chapter Heading should be mentioned for all items where VAT is applicable .					

For and On behalf of BHEL.



A4 - 10

**PURCHASE SPECIFICATION FOR
GATE DRIVER EVALUATION FACILITY
GROUP : TRACTION ENGINEERING**

P.S NO. : PS/445/057

REV. NO : 00

PAGE 01 OF 14

**PURCHASE SPECIFICATION FOR
GATE DRIVER EVALUATION FACILITY.**

EQUIPMENT : IGBT GATE DRIVER TEST PANEL

1 TITLE: Test panel for IGBT Gate drivers and IGBT stack using half bridge/ single arm topology using IGBT devices from 1700 V to 6500 V.

2 PURPOSE:

A test setup for IGBTs stack including viz IGBT gate drivers and any additional protective circuits are required. This test setup would be used to study the switching and short circuit characteristics of the IGBTs under different topologies, drive and load conditions. Two different topologies are to be implemented viz. two-level and three-level half-bridge topologies. This setup will also be used to evaluate Gate drivers, Gate drive power supplies from various vendors.

3 SCOPE OF SUPPLY:

The scope of this specification covers design, manufacture, test, supply, installation, commissioning of the IGBT Gate driver Test panel.

The IGBT power circuits for the two topologies are given in Fig1 and Fig2.

The overall system diagram is shown in Fig3.

The test system consists of:

- (i) H-bridge circuit for 1700V, 1800A IGBTs, as per Fig1.
- (ii) H-bridge circuit for 3300V, 1200A IGBTs, as per Fig1.
- (iii) H-bridge circuit for 4500V, 900A IGBTs, as per Fig1.
- (iv) 3-level half-bridge circuit for 4500V, 900A IGBTs, as per Fig2.
- (v) 3-level half-bridge circuit for 6500V, 600A IGBTs, as per Fig2.
- (vi) H-bridge circuit for 6500V, 600A IGBTs, as per Fig1.
- (vii) Individual 3-phase bridge rectifiers for each IGBT inverter. Series connected bridges can be used for the high voltage inputs wherever needed.
- (viii) Isolation, step-up transformer for each circuit.
- (ix) Contactors, interlocked to operate only one circuit at a time.
- (x) 3-phase variac (continuously variable auto-transformer) rated at 30kVA.

COPYRIGHT AND CONFIDENTIAL
The information on this document is the property of BHARAT HEAVY ELECTRICALS LIMITED.
It must not be used directly or indirectly in anyway detrimental to the interest of the company.

REVISIONS 00 DT: 18.08.2008

APPROVED BY : C.A.KESHAVA MURTHY (AGM)

PREPARED BY

V. VENKATESH (DGM)

ISSUED BY

TRACTION

DATE

18.08.2008



A4 – 11

**PURCHASE SPECIFICATION FOR
GATE DRIVER EVALUATION FACILITY
GROUP : TRACTION ENGINEERING**

P.S NO. : PS/445/057

REV. NO : 00

PAGE 02 OF 14

- (xi) A signal generator board based on DSP.
- (xii) A load reactor of 200 uH with tap at 70uH and 500A.
- (xiii) All components are to be housed within a suitable enclosure, with protective switchgear, except for the variac. The variac is to be mounted on castors, and connected externally.

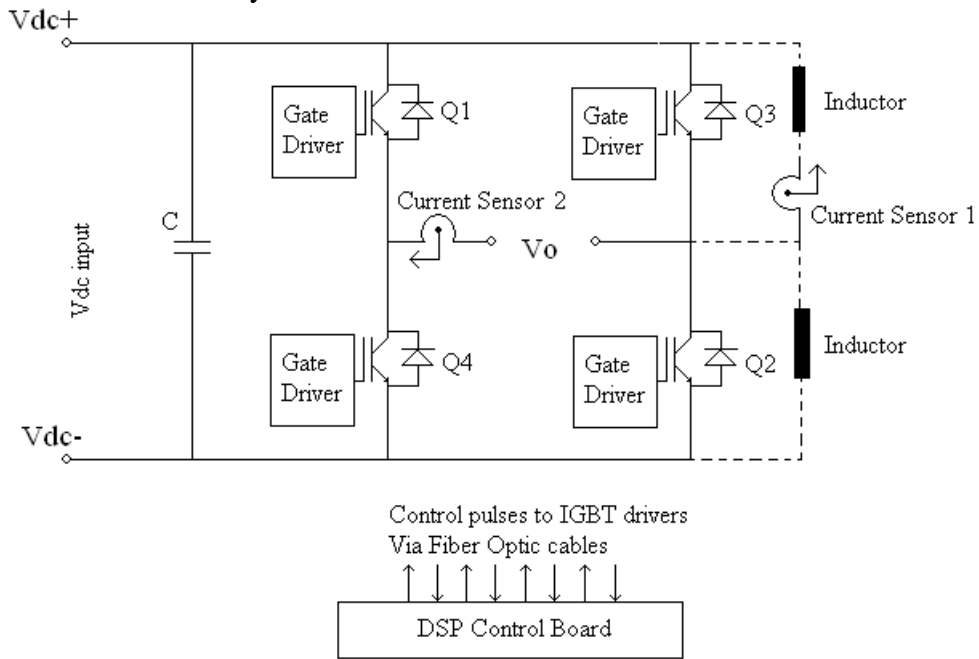

Fig.1.

4 Pre Qualification Criteria :

- 4.1 The vendor shall be an Original Equipment Manufacturer (OEM). Only the OEM or their authorized dealers in India along with an authorization letter can submit offers. An authorized Representative/Dealer in India, cannot quote for the same equipment from more than one OEM.**
- 4.2 Offer shall be for a new equipment and not for any refurbished / used equipment. All the parts used in the machine shall also be new and not used / refurbished ones. A declaration to the above effect to be furnished.**
- 4.3 Foreign OEM shall have Authorized Indian dealer(s) / representative(s) for After- sales service and support. The authorization letter for the dealer/ representative shall be provided.**
- 4.4 The vendor should have already supplied HV IGBT based power stacks/ 500 KVA UPS / 500KVA inverter for power electronics application such as induction heating, STATCOM etc, / 500 KW VFD and installed equipments in India during the past 5 years and these must be operating satisfactorily for at least past one year. The details of the customers with contact details, equipments installed, date of installations etc. to be provided.**



A4 – 11

**PURCHASE SPECIFICATION FOR
GATE DRIVER EVALUATION FACILITY
GROUP : TRACTION ENGINEERING**

P.S NO. : PS/445/057

REV. NO : 00

PAGE 03 OF 14

- 4.5 The vendor or their authorized service representatives shall have trained engineers in India for commissioning & service for the offered equipment and shall be in a position to provide prompt after sales service and spares support for our installations.
- 4.6 The vendor shall be in a position to undertake AMC or provide service support for the equipment supplied, after the expiry of the warranty/ guarantee period either directly or through a service representative.
- 4.7 The vendor shall furnish a warranty for at least 12 months from the date of commissioning.

COPYRIGHT AND CONFIDENTIAL
The information on this document is the property of BHARAT HEAVY ELECTRICALS LIMITED.
It must not be used directly or indirectly in anyway detrimental to the interest of the company.

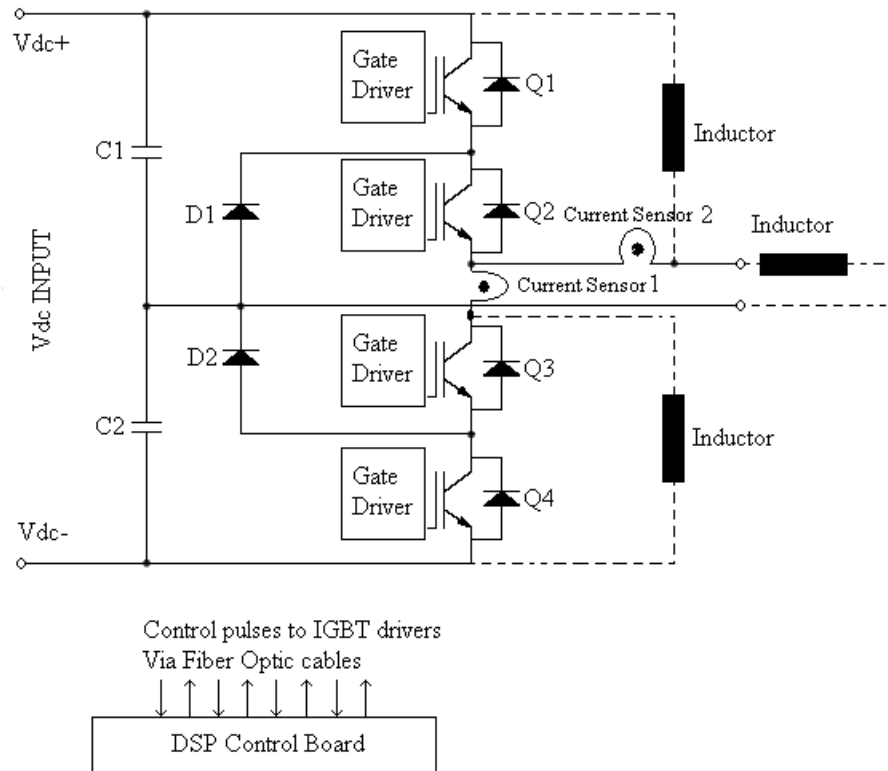

Fig.2.

5 BIDDING SYSTEM:

Bid shall be submitted in two parts (Part I and Part II).

5.1. Part –I shall be Techno – commercial bid with complete technical contents, delivery, payment terms, validity, taxes and duties wherever applicable.

5.2. Part – II shall be exclusively price bid.



A4 – 11

PURCHASE SPECIFICATION FOR GATE DRIVER EVALUATION FACILITY GROUP : TRACTION ENGINEERING

P.S NO. : PS/445/057

REV. NO : 00

PAGE 04 OF 14

6 TECHNICAL SPECIFICATION:

The system is rated for pulse loading of the IGBTs, hence the input power rating is small. The capacitors used are polypropylene type. The vendor must specify the make and type of the capacitor.

Salient features of the system to be supplied:

1. The individual IGBT assemblies have to be designed for ease of operation, monitoring, troubleshooting, and repair.
2. Proper insulation levels should be provided for the IGBT assemblies.
3. The heat sink and body of the enclosure must be properly earthed.
4. The IGBT stacks should be designed for easy replacement of IGBTs when the need arises.
5. By inserting CURRENT SENSOR1 in the series path as shown fig 1, fig 2, the free wheel diode reverse recovery current can also be observed.

COPYRIGHT AND CONFIDENTIAL
The information on this document is the property of BHARAT HEAVY ELECTRICALS LIMITED. It must not be used directly or indirectly in anyway detrimental to the interest of the company.

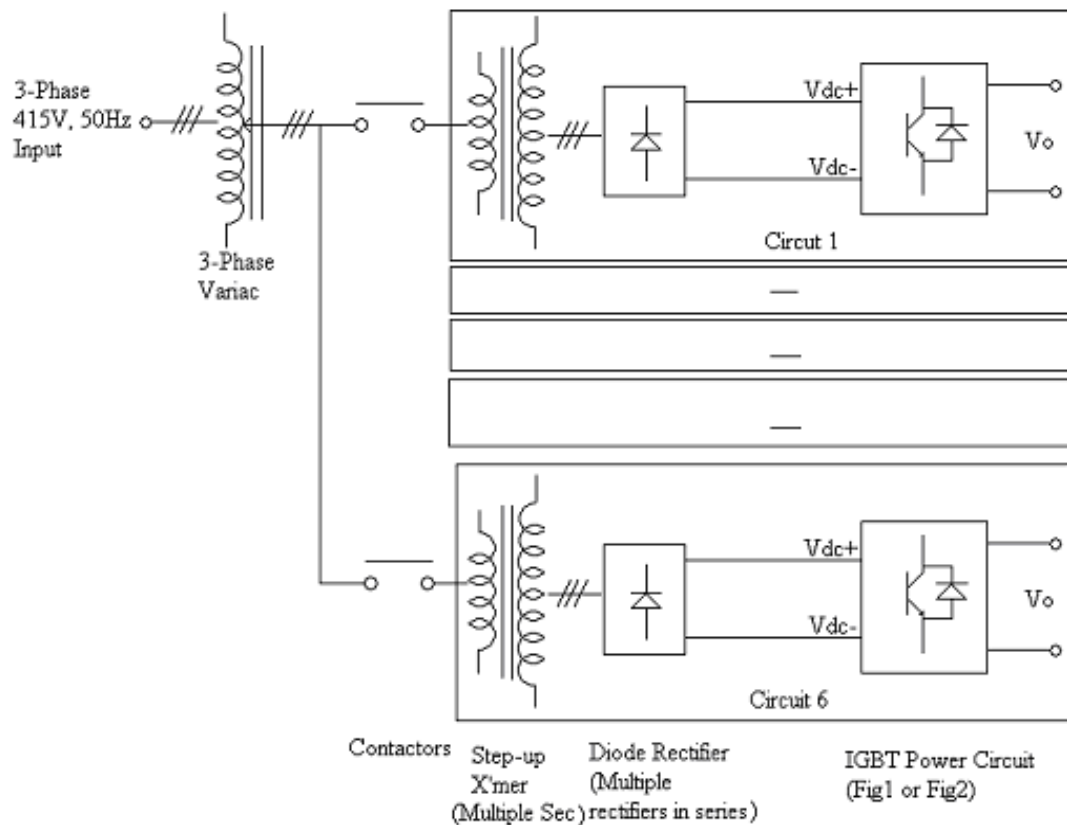

Fig.3



A4 – 11

**PURCHASE SPECIFICATION FOR
GATE DRIVER EVALUATION FACILITY
GROUP : TRACTION ENGINEERING**

P.S NO. : PS/445/057

REV. NO : 00

PAGE 05 OF 14

7.0. TESTING:

Along with the routine tests being done by supplier the following test shall be conducted.

7.1. TESTING OF 2 LEVEL HALF BRIDGE CIRCUIT BY DUAL PULSE METHOD

An Air core inductor of 70 μ H is connected between positive bus and output of half bridge circuit as a load. By switching Transistor T_4 on and off with two narrow pulses (about 20 to 30 μ s), the current through the inductor is ramped up, and turned off at rated current. In this test switching parameters at rated current can be measured. This cycle is repeated at low frequency (typical 1Hz), thus the average losses are minimal.

Fig.4 (b) shows the lower commutation path. Fig.5 shows the voltage at turn off for T_4 . The overvoltage is measured across the device and shall be within limits as per the rating of device. Fig.6. shows the lower Diode measurements during turn on of the second current pulse. The dual pulse testing waveforms of current is shown in Fig.7 ,

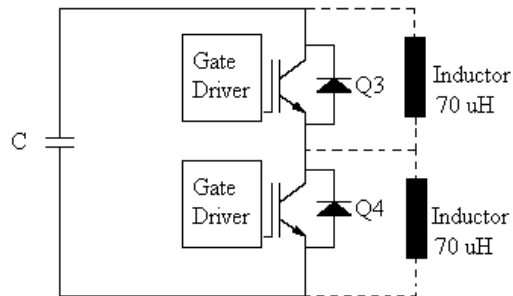

Fig 4 (a)

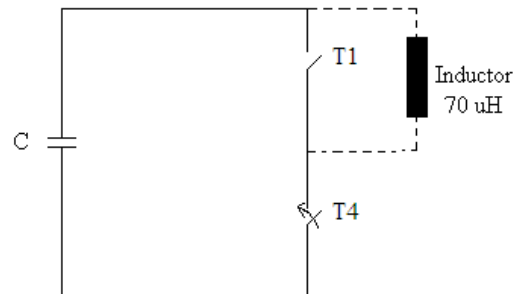

Fig 4 (b)

COPYRIGHT AND CONFIDENTIAL
The information on this document is the property of BHARAT HEAVY ELECTRICALS LIMITED.
It must not be used directly or indirectly in anyway detrimental to the interest of the company.



A4 - 11

**PURCHASE SPECIFICATION FOR
GATE DRIVER EVALUATION FACILITY
GROUP : TRACTION ENGINEERING**

P.S NO. : PS/445/057

REV. NO : 00

PAGE 06 OF 14

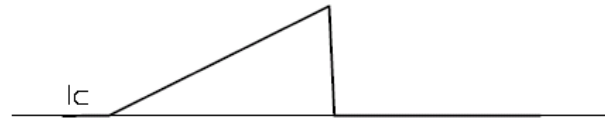

IGBT Measurements during turn-off of the current pulse:

t_{sv} , t_{si} , t_{rv} , t_{fi} , t_c , t_{ti} , E_{off}

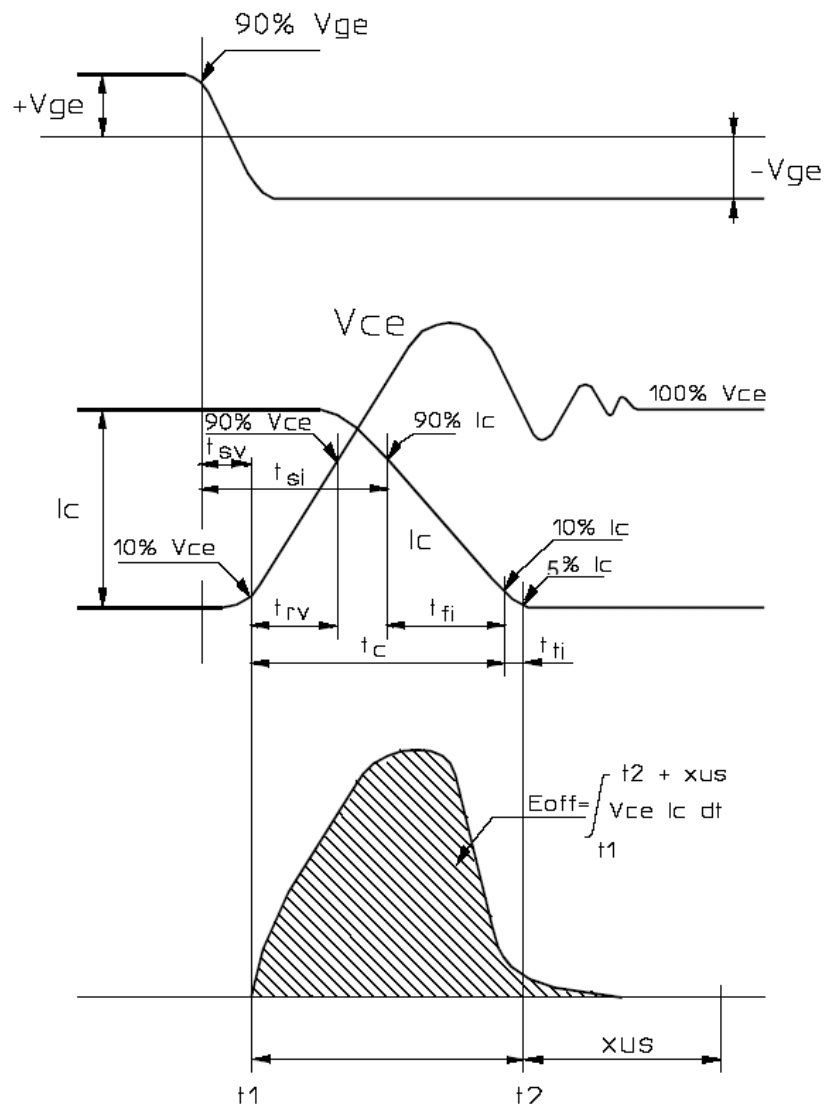

Fig.5

COPYRIGHT AND CONFIDENTIAL
The information on this document is the property of BHARAT HEAVY ELECTRICALS LIMITED.
It must not be used directly or indirectly in anyway detrimental to the interest of the company.



A4 - 11

**PURCHASE SPECIFICATION FOR
GATE DRIVER EVALUATION FACILITY
GROUP : TRACTION ENGINEERING**

P.S NO. : PS/445/057

REV. NO : 00

PAGE 07 OF 14

COPYRIGHT AND CONFIDENTIAL
The information on this document is the property of BHARAT HEAVY ELECTRICALS LIMITED.
It must not be used directly or indirectly in anyway detrimental to the interest of the company.

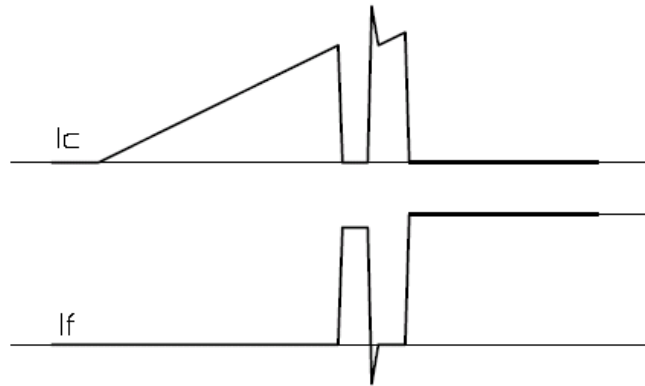

Diode Measurements during turn-on of the second current pulse:

I_{rr} , t_{rr} , Q_{rr} , di/dt , E_{rec}

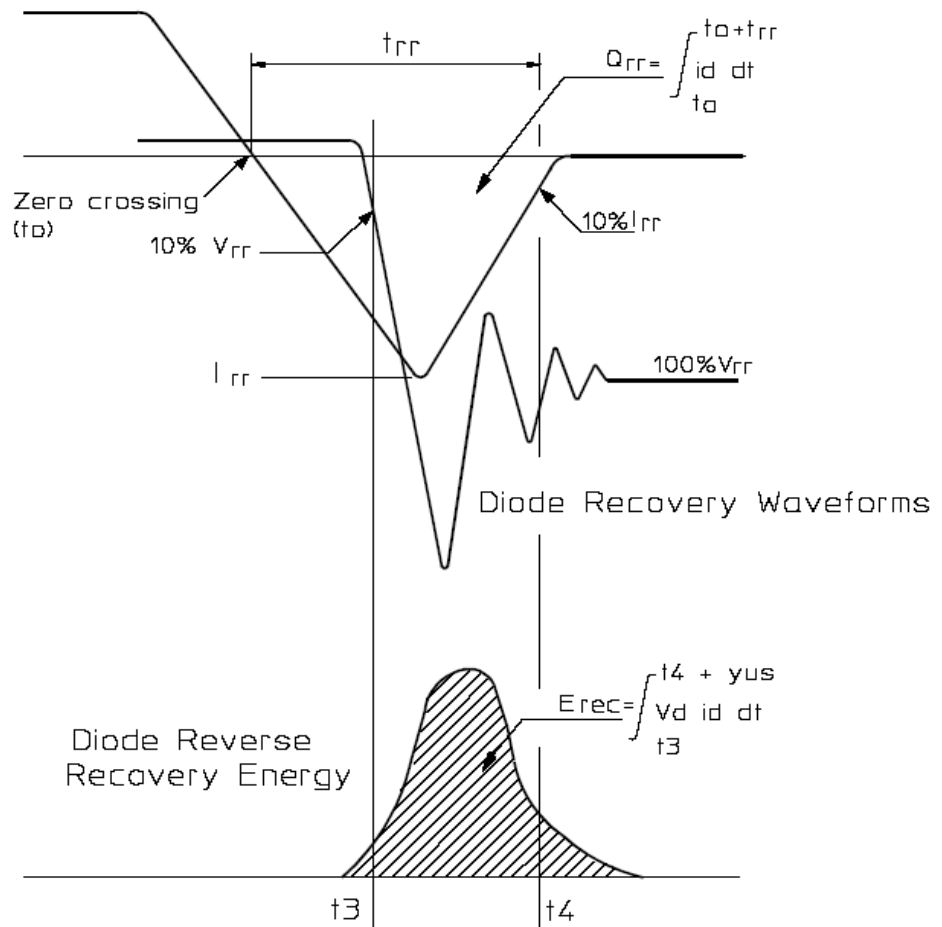

Fig.6



A4 - 11

**PURCHASE SPECIFICATION FOR
GATE DRIVER EVALUATION FACILITY
GROUP : TRACTION ENGINEERING**

P.S NO. : PS/445/057

REV. NO : 00

PAGE 08 OF 14

COPYRIGHT AND CONFIDENTIAL
The information on this document is the property of BHARAT HEAVY ELECTRICALS LIMITED.
It must not be used directly or indirectly in anyway detrimental to the interest of the company.

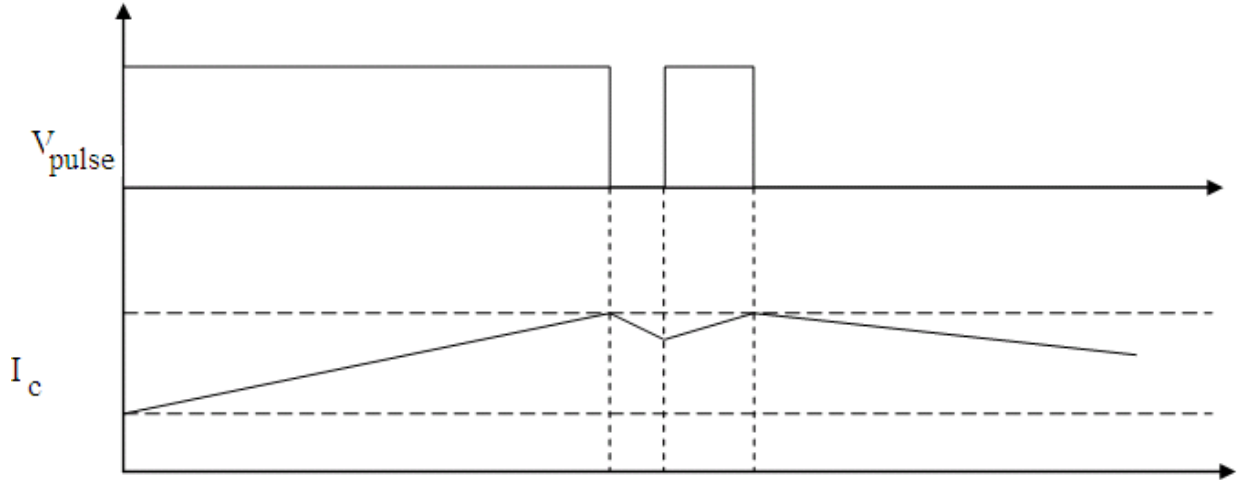

Fig.7.

7.2. TESTING OF 3 LEVEL HALF BRIDGE CIRCUIT BY DUAL PULSE METHOD

An Air core inductor of $70 \mu\text{H}$ is connected between DC bus midpoint and output of half bridge circuit. By switching Transistor T_2 on and off with two narrow pulses (about 20 to 30 μs), the current through the inductor is ramped up, and turned off at rated current I_n in this test switching parameters at rated current can be measured. This cycle is repeated at low frequency (typical 1Hz), thus the average losses are minimal.

Fig 8(b) shows the voltage at turn off for T_1 . Fig.5 shows the voltage at turn off for T_4 . The overvoltage is measured across the device and shall be within limit as per the rating of device. Fig.6. shows the lower Diode measurements during turn on of the second current pulse. The dual pulse testing waveforms

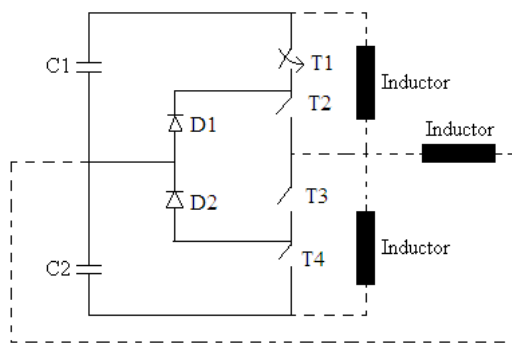

Fig.8 (a)

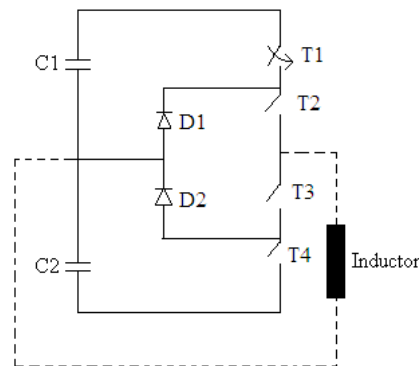

Fig 8 (b)



A4 – 11

**PURCHASE SPECIFICATION FOR
GATE DRIVER EVALUATION FACILITY
GROUP : TRACTION ENGINEERING**

P.S NO. : PS/445/057

REV. NO : 00

PAGE 09 OF 14

of current is shown Fig.7.

Sl.No.	Device under test being turned on and turned off	Devices always ON	Devices always OFF	Devices ON and OFF	Inductor connection	
					From	To
1.	T ₁	T ₂	T ₃ , T ₄	NIL	output	DC bus Midpoint
2.	T ₄	T ₃	T ₁ , T ₂	NIL	output	DC bus Midpoint
3.	T ₂	T ₃	T ₁	T ₄	Output	DC bus Negative
4.	T ₃	T ₂	T ₄	T ₁	Output	DC bus Positive

Table.1

Similarly the waveforms as shown in fig.5, fig.6, fig.7, for devices T₂, T₃, T₄ are measured with conditions as per serial number 2,3,4 of Table.1.

7.3. ADDITIONAL INFORMATION ON THE VARIOUS PULSES TO BE MADE AVAILABLE FOR THE TESTS:

1. Single Pulse:

For tests such as the shoot through test: 5µSec Max

Non Repeatable for 5 minutes.

(One should bear in mind the limited life; i.e. less than 1000 times; of such a test).

2. Pulse Train: T_{on} ; T_{off} & Synchronizing Signal:

20µSec = T_{on} = 2mSec; followed by T_{off}; where T_{off} is 20µSec = T_{off} = 2mSec;

Repeated “N” times; along with a synchronizing pulse for starting the sequence.

Protection should be inbuilt to terminate the remainder of the ON pulse; wherever the IGBT current exceeds 80% of its rated value. This would be on cycle by cycle current limit basis (CBCL); so that even in case of an inadvertent set high value of “Ton”, the IGBT’s continue to remain protected.

3. The maximum no. of pulse repeats at a time is limited to 20 (less than 20 are suggested).

The time interval between two such strings of pulse repeats is 10 minutes. This is due to Thermal considerations.

7.4. DETAILS REGARDING THE DSP CONTROLLER OUTPUTS:

1. For the H-Bridge: 4 outputs (2-level), (for the power circuit provided internally).

COPYRIGHT AND CONFIDENTIAL
The information on this document is the property of BHARAT HEAVY ELECTRICALS LIMITED.
It must not be used directly or indirectly in anyway detrimental to the interest of the company.



A4 – 11

**PURCHASE SPECIFICATION FOR
GATE DRIVER EVALUATION FACILITY
GROUP : TRACTION ENGINEERING**

P.S NO. : PS/445/057

REV. NO : 00

PAGE 10 OF 14

- 2. For the 3-phase, 2-level, H-Bridge: 6 outputs, (for any external power circuit).
- 3. For the 3-phase, 3-level, NPC Full-bridge: 12 outputs, (for any external power circuit).

7.5. HUMAN MACHINE INTERFACE:

7.5.1 For the HMI, a 4×4 keypad with a 240×128 dot graphical LCD will be provided. A Serial link based interface will be used to communicate with the DSP controller.

7.6. RFI filter / surge suppressor shall be provided at the mains (incoming) stage as well as at the input stage of critical electronic instruments/systems used in the equipment.

8 DOCUMENTS TO BE SUBMITTED ALONG WITH THE OFFER:

- 1. Clause wise deviations, if any, should be brought out clearly **as per the format provided below for each of the clauses**. If there are no deviations, the vendor has to positively certify compliance to the specifications in toto.
- 2. Detailed reference list including installations in India with details of supply and commissioning dates contact names for systems should be provided along with user certificates.
- 3. Terms of annual maintenance after the agreed warranty/guarantee period should be furnished.
- 4. Outline general arrangement
- 5. Proof of experience with HV IGBTs
- 6. Complete design details with component selection
- 7. Data sheets of selected devices.
- 8. All commissioning / service requirements such as power, compressed air, water, lubricants, coolant, consumables, any civil requirements like special foundations arrangements etc, have to be listed.

Clause no	Page No	Confirmation Yes/No	Remarks comments

9. DOCUMENTS TO BE SUBMITTED AFTER AWARD OF CONTRACT:

- 1. Complete design document, inclusive of calculations, component selection, etc.
- 2. Detailed engineering design and layout drawing for the system
- 3. Detailed data sheets for selected parts
- 4. Maintenance, troubleshooting and repair manual.
- 5. Supplier shall submit quality plan & test protocol for BHEL’s approval before pre-shipment inspection.

COPYRIGHT AND CONFIDENTIAL
The information on this document is the property of BHARAT HEAVY ELECTRICALS LIMITED.
It must not be used directly or indirectly in anyway detrimental to the interest of the company.



A4 – 11

**PURCHASE SPECIFICATION FOR
GATE DRIVER EVALUATION FACILITY
GROUP : TRACTION ENGINEERING**

P.S NO. : PS/445/057

REV. NO : 00

PAGE 11 OF 14

10. PRE-DESPATCH INSPECTION AND TRAINING:

1. Pre-Despatch inspection and training on operation and maintenance of the test panel at manufacturer's works for period of 10 working days shall be included in the offer.
2. Pre shipment inspection shall be carried out as per approval Quality plan and test protocol.
3. Each test for all sub-assemblies and the complete system will be witnessed by BHEL's representative at Supplier's premises.
4. All the facility for the testing of the system shall be provided by the supplier at his premises.

11. SPARES:

All spares including consumables, if any, necessary for two years of trouble-free operation shall be supplied at the time of delivery of equipment to BHEL. The spares shall include critical PCB cards, DSP boards, add-on cards, etc.,

12. INSTALLATION AND COMMISSIONING:

All the tools, Hardware, software and instruments that will be required for installation operation and maintenance of the equipment shall be provided by the supplier. Scope of offer shall include installation and commissioning that includes connecting the equipment to the existing service facilities at BHEL.

13. WARRANTY:

Complete system with controls shall be warranted for satisfactory and trouble free operation for a period of at least 12 months from the date of commissioning.

14. PARAMETERS OF THE IGBT TEST PANEL:

Sl.	PARAMETER	SPECIFICATION		
	IGBT Voltage Rating / Levels	1700V / 2-Level	3300V / 2-Level	4500V / 2-Level
1.	GENERAL			
	Converter Topology	2-Level, H-bridge as per Fig 1.	2-Level, H-bridge as per Fig 1.	2-Level, H-bridge as per Fig 1.
	Bus bar	Laminated bus bar.	Laminated bus bar.	Laminated bus bar.
	Switching Frequency	10kHz maximum	4kHz maximum	2kHz maximum
2.	INPUT			

COPYRIGHT AND CONFIDENTIAL
The information on this document is the property of BHARAT HEAVY ELECTRICALS LIMITED.
It must not be used directly or indirectly in anyway detrimental to the interest of the company.



A4 – 11

**PURCHASE SPECIFICATION FOR
GATE DRIVER EVALUATION FACILITY
GROUP : TRACTION ENGINEERING**

P.S NO. : PS/445/057

REV. NO : 00

PAGE 12 OF 14

COPYRIGHT AND CONFIDENTIAL
 The information on this document is the property of BHARAT HEAVY ELECTRICALS LIMITED.
 It must not be used directly or indirectly in anyway detrimental to the interest of the company.

	Input voltage	1000Vdc maximum	1700Vdc maximum	2200Vdc maximum
3	CAPACITOR BANK			
	Effective Capacitor Bank	1300uF, 1250Vdc.	500uF, 1800Vdc	240uF, 2500Vdc
Sl.	PARAMETER	SPECIFICATION		
	IGBT Voltage Rating / Levels	4500V / 3-Level	6500V / 2-Level	6500V / 3-Level
1.	GENERAL			
	Converter Topology	3-Level, Half bridge as per Fig2	2-Level, H-bridge as per Fig 1.	3-Level, Half bridge as per Fig2
	Bus bar	Laminated bus bar.	Laminated bus bar.	Laminated bus bar.
	Switching Frequency	2kHz maximum	1kHz maximum	1kHz maximum
2.	INPUT			
	Input voltage	5000Vdc maximum	4200V maximum	6500V maximum
3	CAPACITOR BANK			
	Effective Capacitor Bank	250uF, 5800Vdc	100uF, 6000Vdc	150uF, 6800Vdc

Type	Polypropylene
PROTECTIONS	
Shoot through	Protection by V_{ce} De sat detection
Over temperature	Heat sink over temp at 80 °C Normally closed type of temperature sensor.
Over Current	Load current sensed by fast current sensor (closed loop hall effect type). Protection circuit should act to disable the IGBT pulses when load current exceeds 125% of IGBT rated current.
SENSORS AND PROBES	
Current sensors	2 nos. one each for dc and output current.
Voltage probe	1 differential probe mounted within the panel (Pintek or suitable, make – one probe common to all stacks)
COOLING SYSTEM	
Type	Forced air-cooling with blower or axial fan.
ENVIRONMENT	



A4 – 11

**PURCHASE SPECIFICATION FOR
GATE DRIVER EVALUATION FACILITY
GROUP : TRACTION ENGINEERING**

P.S NO. : PS/445/057

REV. NO : 00

PAGE 13 OF 14

Ambient temperature	0 to 45°C
Humidity	90% RH max. Non Condensing
ENCLOSURE	
Construction	Floor mounted panel
Protection class	IP41
Finish	Epoxy paint (Powder coating)
Colour	Main panel body: Siemens gray. Panel plinth: Black.
GENERAL & INTERFACE	
IGBT driver inputs	Fiber Optic interface using HFBR1532 (Rx) and HFBR2532 (Tx)

15.0. General:

- 15.1. The supplier shall provide all the items required for proper functioning of the equipment in accordance with the latest international practices/standards, whether included in this specification or otherwise.
- 15.2. Any deviation from specification intended to improve the performance, reliability and efficiency of the equipment as a whole or part thereof may be proposed for consideration. All such proposals shall, however, be accompanied with complete technical details and justification for proposed deviation.
- 15.3. Three sets of operation and maintenance manual in English shall be supplied along with the equipment. The manual shall include circuit diagram, component layout, PCB artwork, trouble shooting chart including symptoms, checks and preventive maintenance schedule to be carried out, suggested remedy for all items including the bought out items.
- 15.4. The equipment shall be designed taking into account all safety and environmental requirements. Hazards/Risks associated with operation & maintenance of the equipment shall be brought out explicitly and instructions for minimizing the Hazards/Risks are to be indicated.
- 15.5. The equipment shall be aesthetically designed and manufactured.
- 15.6. Supplier's operators /Engineers deputed for installation of the equipment at the BHEL

COPYRIGHT AND CONFIDENTIAL
The information on this document is the property of BHARAT HEAVY ELECTRICALS LIMITED.
It must not be used directly or indirectly in anyway detrimental to the interest of the company.



A4 – 11

**PURCHASE SPECIFICATION FOR
GATE DRIVER EVALUATION FACILITY
GROUP : TRACTION ENGINEERING**

P.S NO. : PS/445/057

REV. NO : 00

PAGE 14 OF 14

works shall comply with safety regulations and precautions. They shall have adequate training in environmental/safety Hazards/Risks associated with the installation and operation of the equipment.

15.7. Final acceptance will be given after satisfactory commissioning and trial runs at BHEL for the rated output parameters.

15.8. Vendor shall submit model number, datasheet and all related technical details along with the offer.

COPYRIGHT AND CONFIDENTIAL
The information on this document is the property of BHARAT HEAVY ELECTRICALS LIMITED.
It must not be used directly or indirectly in anyway detrimental to the interest of the company.

Bharat Heavy Electricals Ltd.,

(A Government of India undertaking)

Electronics Division

PB No.2606, Mysore Road, Bangalore-560026,India

Ph: +91-80-26742974 / 26998609

Fax: +91-80-26740138

**General Terms & Conditions for Supply of Imported & Indigenous
Capital Items (Two part bid)**

Bidders are required to read the general terms & conditions carefully and submit their quotation covering all the points. Any order resulting from this enquiry shall be governed by the general terms and conditions listed below.

1. **TWO PART BID:** Quotation shall be submitted in two part bid i.e.

- a) **Techno-commercial i.e., Un-priced Bid:** Techno-commercial bid shall be submitted with complete description of the equipment, specification compliances to the enquired specification and all the commercial terms & conditions indicated in the **QUOTATION FORMAT (ANNEXURE - A / ANNEXURE - B)** preferably in the same format. Any other enclosure, which the supplier wishes to submit like product catalogue, technical literature etc., may also be submitted in a sealed envelope super scribed clearly as **“TECHNO-COMMERCIAL BID” with RFQ No. and DUE DATE.** Un-priced copy of price bid (without price) shall also be enclosed with the techno-commercial bid i.e. a copy of the price bid without prices.

Confirmation to BHEL specifications shall be indicated by the vendor in the respective columns provided in the purchase specification wherever applicable. Deviations to the specification / item description, if any shall be brought out clearly indicating **“DEVIATION TO BHEL SPECIFICATION”** without fail as a part of technical offer.

Compliance to Pre-qualification criteria (if applicable) shall also be enclosed with the Techno-commercial bid.

Manufacturer's name, their trade mark and brand if any, should be invariably mentioned in the tender and illustrative leaflets giving technical particulars etc., are to be attached to the tender to facilitate consideration of the offer.

b) **Price Bid :**

Price bid should contain basic unit prices, discount if any, applicable taxes & duties, packing & forwarding charges (if applicable), Freight & insurances (if applicable) FOB charge (if applicable) etc., in a sealed envelope super scribed clearly as **“PRICE BID” with RFQ No. and DUE DATE.** Installation, commissioning, start-up and training charges (if any) shall also be included in the price bid.

Please indicate the rates in both figures and words. However in case of difference / discrepancy, the rates indicated in figures shall be considered as correct.

Both these sealed envelopes [(a) Techno-commercial i.e., un-priced Bid and (b) Price Bids] shall be kept in a single sealed envelope and superscribed clearly with **RFQ No. and DUE DATE.**

2. The above sealed envelope (Tender) shall reach our office on or before the due date by **13:00 hrs.** Quotations are to be dropped in the tender box marked for the OPENING ON respective days i.e., MONDAY / WEDNESDAY / FRIDAY kept at BHEL-EDN's Reception area of our works with caption "CE, M&C, SC&PV, TSC, DEFENCE, TELECOM, CPD". Quotations also can be dispatched by Couriers / Registered post / FAX / e mail to the Purchase Executive indicated in the RFQ. Late Tenders i.e. Tenders received after due date & time are liable to be rejected.
3. The rates quoted against each item shall be in the same units stated in the enquiry. If the quotations are submitted in any other unit than specified, relationship between two sets of units must be furnished in the offer.
4. As far as possible, the quotations shall be free from corrections / overwriting. Corrections if any should be initialed with your seal and signature. Any typographical errors, totaling mistakes, currency mistakes, multiplication mistakes, summary mistakes observed in your priced bids, BHEL may consider whichever is beneficial to BHEL for evaluation.
5. Quotations are to be duly signed. Unsigned bids/offers are liable for rejection.
6. All the bidders or their authorized representatives (with authorization letter from their principals) can witness opening of techno-commercial bid on the due date.
7. After evaluation of techno-commercial bids, price bids of only those which are technically & commercially accepted, will be opened on a subsequent date, which will be intimated to the concerned in advance for witnessing of price bid opening.
8. The quantities in each item to be purchased may vary from quantities enquired according to the actual requirement at the time of placing the purchase order. Quantity discount if any should be mentioned in your offer.
9. BIDDERS (for indigenous purchase) shall indicate clearly Excise duty, Education cess, Sales Tax/VAT, Octroi, Entry tax, Service Tax as applicable for the quoted items. In the absence of clarity of these, any claim at a later date will not be entertained. Any changes in Taxes and duties after award of the contract will not be considered except such are those, which are imposed by Govt., notification within the contractual delivery. Seeking price amendments for change in Excise duty due to crossing of turnover limits will not be considered under any circumstances.
10. **TOTAL COST TO BHEL:** Purchase order will be placed on the lowest bidder (L1) only among the technically & commercially accepted offers. Lowest Bid (L1) is determined on the basis of the total cost to BHEL.

(a) FOR FOREIGN PURCHASE:

Total cost to BHEL = Total basic value in foreign currency + FOB charges (if any) + Packing & Forwarding charges (if any) + Cost Insurance Freight (CIF) + Basic Custom Duty (BCD) + Counter Veiling Duty (CVD) + Educational Cess + Special Additional Duty (SAD) + Entry TAX + Service TAX (if applicable) + Loading factors for deviations to commercial terms & conditions.

Note: Exchange rate ruling on the date of Tender opening (Techno-commercial / un-priced Bid) will be considered for converting foreign currency to Indian currency. Exchange rates published in Economic Times (TT selling) will be considered.

(b) FOR INDIGENOUS PURCHASE:

Total cost to BHEL = Total basic value + Packing & forwarding charges + Excise duty Education cess + sales Tax/VAT + Octroi + Exit/Entry tax + Freight & Insurance + Service Tax (if applicable) + Loading factors for deviations to commercial terms & conditions.

11. FIRM PRICE: Rates quoted should be firm and no enhancement in the rates and changes in the techno-commercial terms will be allowed once the quotation is accepted and order is placed.

If Installation & Commissioning is in supplier's scope, then the price shall remain FIRM till commissioning & handing over of the complete system.

12. TERMS OF PAYMENT:

(a) FOR FOREIGN PURCHASE:

Payment will be made against “**SIGHT DRAFT**” on presentation of documents to our bankers. Payment through LC is also made subject to loading factors as per **Clause 26 (Ai)**.

The payment terms are as follows:

- a) 75 % against complete dispatch documents i.e. AWB / BOL, Invoice, Packing list, Warrantee certificate, Nil shortage certificate, Certificate of country of origin etc.
- b) 15 % on successful installation, commissioning and start-up trials.
- c) 10 % on submission of Performance Bank Guarantee (PBG)
- d) If PBG is not submitted by the vendor, then the final 10% payment will be made against submission of supplementary invoice after warranty period + 6 months of claim period.

(b) FOR INDIGENOUS PURCHASE:

- a) 90% within 30 days from the date of receipt of equipments & balance 10% against submission of PBG (where commissioning is NOT involved).
- b) 75% within 30 days from the date of receipt of equipments, 15% after the successful installation, commissioning & start-up trials & balance 10% against submission of PBG (wherever commissioning is involved).
- c) If PBG is not submitted by the vendor, then the final 10% payment will be made against submission of supplementary invoice after warranty period + 6 months of claim period.

13. ADVANCE PAYMENT: Quotations with payment terms of “**Advance**” or “**Inland Letter of Credit**” will not be considered and such offers are liable for rejection commercially.

14. PENALTY: Failure to supply the item within the delivery date specified in the purchase order will make the supplier liable to an unconditional penalty of ½% (One half percent) of the basic value of the goods in arrears per week subject to a maximum of 10%.

If pre-shipment inspection is involved, date of issue of pre-shipment call by the vendor along with test certificates / test reports / certificate of conformance / calibration reports as proof of completion will be treated as date of dispatch for the purpose of penalty calculation.

In the absence of reports stated above, actual date of inspection will be considered as date of dispatch for penalty calculation.

- 15. PBG:** Performance Bank Guarantee (PBG) to be submitted as per the BHEL prescribed format given in **ANNEXURE - D / ANNEXURE - E** for 10% of the basic equipment value obtained from any BHEL member banks.

PBG shall be valid for 12 months from the date of commissioning or 18 months from the date of dispatch whichever is earlier. The PBG shall also have 6 months claim period from the date of dispatch / commissioning.

The Bank Guarantee shall be submitted directly to the concerned Purchase Executive by the issuing Bank with their forwarding letter.

- 16. WARRANTY:** Goods dispatched shall have warranty period of 12 months from the date of dispatch or as mentioned in the RFQ.

17. TERMS OF DELIVERY:

(a) FOR IMPORTED PURCHASE:

Price offered shall be for goods packed and delivered **F.O.B.** (named international Airport) including packing, forwarding, Handling, Ancillary charges like processing of Sight Draft, Letter of credit (L/C) if applicable, negotiation of bank documents, Export declaration, Certificate of origin etc.

Packing shall be Airworthy & Roadworthy, best suitable for trans-shipment and to prevent transit damages.

Vendors shall indicate the name of International Airport.

Note: Name of International Airport has to be selected from any one of the airports indicated in the table provided in **ANNEXURE - C** herewith.

(b) FOR INDIGENOUS PURCHASE:

Equipment shall be delivered on EX-EDN/BHEL, Bangalore basis, inclusive of packing & forwarding charges.

Packing shall be Road / Air / Rail worthy, best suitable for transshipment and to take care of transit damages.

Dispatch the consignments through EDN/BHEL approved transporters on Door Delivery basis furnished below.

1. M/s Awagaman Road Carriers Ltd., Bangalore. (AWG)
2. M/s BLR India pvt., Ltd., Bangalore. (BLR)
3. M/s Delhi Assam Roadways corporation Ltd., Bangalore. (DRL)
4. M/s Indo Arya Central transport Ltd., Bangalore. (IACT)
5. M/s Prakash parcel Services, Bangalore. (PPS)
6. M/s Road Carrier of India, Bangalore. (RCI)
7. M/s Union Roadways Ltd., Bangalore. (URL)

Small consignments can be dispatched through M/S First Flight Couriers Ltd.

Transit insurance shall be arranged by BHEL. Vendor shall intimate the dispatch details to BHEL immediately after effecting shipment, to arrange transit insurance accordingly.

18. DELIVERY REQUIREMENT: Equipment shall be delivered, as per the delivery schedule indicated in the RFQ.

19. VALIDITY: Quotation should remain valid for a period of **90 days** from the date of technical bid opening.

20. BHEL reserves the right to RE-FLOAT/REJECT/CANCEL the TENDER ENQUIRY (RFQ) without assigning any reason or cause thereof. Quotes received against this TENDER ENQUIRY are subject to and governed by all these terms and conditions. BHEL's decision will be final in awarding of the contract and binding on all vendors.

21. REVERSE AUCTION: BHEL reserves the right to resort to reverse auction / online Bidding before opening of price bid.

22. POST-ORDER REQUISITES:

- a) Pre-shipment inspection at vendor's works, if required, will be carried out by BHEL. Required assistance will have to be provided by the vendor at the time of pre-shipment inspection.
- b) Test certificates, Calibration certificates and warranty certificates as stipulated at the time of ordering shall be furnished.
- c) Items shall be dispatched by Air/Road/Sea worthy packing. Any damage and later rejection, due to poor / improper packing shall be to supplier's account.
- d) Any damage/rejection should be made good or replaced immediately without any extra cost to BHEL.
- e) Wherever commissioning is involved, it shall be carried out by the vendor's qualified engineers. Scope of work includes installation, commissioning and start-up trials till satisfactory performance level is reached as certified by BHEL.
- f) BHEL will not be responsible for any loss, damage or injuries to vendor's personnel sustained during installation / commissioning / start-up trials. Vendor shall ensure compliance with all statutory requisites as laid down by local bodies, state & Central Government.
- g) Performance Bank Guarantee to be executed on Rs.100/- non-judicial stamp paper as per BHEL prescribed format as given as Annexure (c).

23. Any dispute arising out of this contract shall be referred to the sole arbitration of Head of Materials Management, Control Equipment, BHEL, EDN, Bangalore or any other officer nominated by him and his decision shall be final and binding on the parties. The venue of the arbitration in all cases shall be Bangalore.

24. All suits in respect of the above lie in the court of Jurisdiction of Bangalore (India) only.

25. Equipment shall comply with the standard requirements of ISO 14001 & OHSAS 18001.

26. REGRET LETTER: In case, the supplier is unable / not willing to quote (for BHEL's registered vendors), a letter of regret shall be sent.

27. LOADING FACTORS:

Loading factors as detailed below will be added to the quoted price (basic) to evaluate the lowest quote for non compliance of BHEL standard commercial terms.

A(i). For non compliance of standard Terms of payment (For Foreign Purchase Orders)

SI. No.	BHEL standard term	If you quote	Loading factor in % for non-compliance
1	100% against "SIGHT DRAFT" on presentation of dispatch documents to our Bankers.	(a) 100% Through Letter of Credit (LC)	(a) 3.50 %
2	90% against "SIGHT DRAFT" + 10% against PBG (wherever PBG is involved)	(b) 90% Through Letter of Credit (LC)	(b) 2.25 %
3	75% against "SIGHT DRAFT" + 15% after commissioning + 10% against PBG (wherever commissioning & PBG is involved)	(c) 75% Through Letter of Credit (LC)	(c) 1.875 %

A(ii). For non compliance of standard Terms of payment (For Indigenous Purchase Orders)

SI. No.	BHEL standard term	If you quote	Loading factor in % for non-compliance
1	100% within 30 days from the date of receipt (credit payment)	Payment through bank	2 % x percentage quoted through bank
		Payment against proforma invoice	1.25 % x percentage quoted through proforma invoice
2	90% within 30 days from the date of receipt + 10% against PBG (wherever PBG is involved)	Payment through bank	2 % x percentage quoted through bank
		Payment against proforma invoice	1.25 % x percentage quoted through proforma invoice
		100% within 30 days from the date of receipt & PBG	Nil
3	75% within 30 days from the date of receipt + 15% after commissioning + 10% against PBG (wherever commissioning & PBG is involved)	Payment through bank	2 % x percentage quoted through bank
		Payment against proforma invoice	1.25 % x percentage quoted through proforma invoice
		100% within 30 days and after commissioning &	Nil

		PBG	
--	--	-----	--

B. For non compliance of Penalty clause:

Sl. No.	BHEL standard term	If you quote	Loading factor for non-compliance
1	Penalty of 0.5% per week subject to max. of 10% on the basic value of the items not supplied /delayed	Not agreed.	10 %
		5% max., agreed.	5%
		Other than the above.	10% - (minus) agreed max. %

C. For non compliance of Performance Bank Guarantee (PBG):

Sl. No.	BHEL standard term	If you quote	Loading factor for non-compliance
1	PBG for 10% of the basic material cost shall be furnished in the BHEL prescribed format.	Not agreed.	10 %
		5% agreed.	5 %
		Other than the above.	10% - (minus) agreed max. %

D. For Non conformance to delivery requirement indicated in the RFQ:

Sl. No.	BHEL standard term	If you quote	Loading factor for non-compliance
1	Delivery requirement as indicated in the RFQ in number of weeks from the date of issue of PO or from the document approval	Not agreed for the stipulated delivery in the enquiry	1 % per week up to max. of 10% for the difference in period

E. For non compliance of Warranty:

Sl. No.	BHEL standard term	If you quote	Loading factor for non-compliance
1	12 months from the date of dispatch or as indicated in the RFQ	Not agreed.	6%
		Less than 12 months or as indicated in the RFQ	0.5 % per month for the difference in period

ANNEXURE - A

TECHNICAL BID (TO BE ENCLOSED WITH TECHNO-COMMERCIAL BID)
(for Foreign Purchase Orders)

Sl. No.	Particulars	Bidder's confirmation
1	Price basis: Firm i.e., from the date of PO to completion of supply [Price Variation Clause (PVC) not acceptable]	Acceptable / Not acceptable
2	Terms of Payment: Against "SIGHT DRAFT" on presentation of documents to our bankers. (a) 90 % is payable on negotiation of complete set of original documents & balance 10% against submission of PBG (where commissioning is NOT involved). (b) 75 % is payable on negotiation of complete set of original documents, 15% after satisfactory commissioning & balance 10% against submission of PBG (wherever commissioning & PBG is involved). (c) Deviation if any please specify Note: Refer clause 12 above .	(a) Acceptable / Not acceptable (b) Acceptable / Not acceptable (c)
3	BHEL's penalty clause: (a) Delay in delivery as per PO delivery date will result in penalty of 0.5 % per week subject to maximum of 10% on the value of the items not supplier/delayed. (b) Deviation if any Please specify	(a) Acceptable / Not acceptable (b)
4	Performance Bank guarantee: PBG for 10% of the basic material cost shall be furnished in the BHEL prescribed format as detailed in clause 15 .	Yes / No
5	Terms of delivery: (a) F.O.B international Airport/Seaport as per clause 17 Indicate name of International Airport/Seaport (b) Deviation if any Please specify	(a)Acceptable / Not acceptable (b)
6	Warranty: (a) 12 months from the date of dispatch (b) Deviation if any Please specify	(a)Acceptable / Not acceptable (b)
7	Delivery period: Indicate number of weeks from the date of issue of Purchase order	_____Weeks
8	Validity: (a) Quotation should remain valid for a period of 90 days from the due date (b) Deviation if any Please specify	(a) Acceptable / Not acceptable (b)

Signature of renderer / with seal

ANNEXURE - B

TECHNICAL BID (TO BE ENCLOSED WITH TECHNO-COMMERCIAL BID)

(For Indigenous Purchase Orders)

Sl. No.	Particulars	Bidder's confirmation
1	Price basis: Firm i.e., from the date of PO to completion of supply [Price Variation Clause (PVC) not acceptable]	Acceptable / Not acceptable
2	Excise duty: If applicable indicate %.	Applicable / Not applicable ED:_____%
3	Sale tax: If applicable indicate %	Applicable / Not applicable (a) VAT_____% (b) CST_____% against form C
4	Payment terms: (a) 90 % basic + 100% taxes, duties & freight charges within 30 days from the date of receipt & balance 10% against submission of PBG (where commissioning is NOT involved) (b) 75 % basic + 100% taxes, duties & freight charges within 30 days from the date of receipt, 15% after satisfactory commissioning & balance 10% against submission of PBG (wherever commissioning & PBG is involved). (c) Deviation if any please specify Note: As per clause 12	(a) Acceptable / Not acceptable (b) Acceptable / Not acceptable (c)
5	BHEL's penalty clause: (a) Delay in delivery as per PO delivery date will result in penalty of 0.5 % per week subject to maximum of 10% on the value of the items not supplier/delayed. (b) Deviation if any Please specify	(a) Acceptable / Not acceptable (b)
6	Performance Bank guarantee (PBG): PBG for 10% of the basic material cost shall be furnished in the BHEL prescribed format as per clause 15 .	Yes / No
7	Terms of delivery: (a) Ex EDN / BHEL, Bangalore (Free delivery to EDN/BHEL Bangalore including packing & forwarding charges) (b) Deviation if any Please specify	(a)Acceptable / Not acceptable (b)
8	Warranty: (a) 18 months from the date of dispatch or 12 months from the date of commissioning (b) Deviation if any Please specify	(a)Acceptable / Not acceptable (b)
9	Delivery period: Indicate number of weeks from the date of issue of Purchase order	_____Weeks
10	Validity: (a) Quotation should remain valid for a period of 90 days from the due date (b) Deviation if any Please specify	(a) Acceptable / Not acceptable (b)

Signature of renderer / with stamp

ANNEXURE - C

LIST OF INTERNATIONAL AIRPORTS

Sl. No	Country	Air Ports
1	Austria	Vienna, Linz, Graz
2	Australia	Sydney, Melbourne, Perth
3	Belgium	Antwerp, Brussels
4	Canada	Toronto, Montreal
5	China	Shangai
6	Cyprus	Lamaca
7	Czech Republic	Prague (Via Frankfurt)
8	Denmark	Copenhagen
9	Egypt	Cairo
10	Finland	Helsinki
11	France	Paris (Rossy), Lyon
12	Germany	Darmstadt, Manihem, Nurnberg, Hamburg, Stuttgart, Munich, Koln, Dusseldorf & Hannover, Frankfurt, Berlin
13	Hongkong	Hongkong
14	Italy	Rome, Milan, Turin, Bologna, Florence
15	Ireland	Dublin
16	Isrel	Telaviv
17	Japan	Tokyo, Osaka
18	Malaysia	Kaulalampur, Penang
19	Neatherlands	Amsterdam, Rotterdam
20	Newzealand	Auckland
21	Norway	Oslo
22	Oman	Muscat
23	Philiphines	Manila
24	Romania	Bucharest
25	Russia	Moscow
26	Saudi Arabia	Riyad
27	Singapore	Singapore
28	Slovakia	Bartislowa
29	South Africa	Johannesburg, Durban
30	South korea	Kimpo
31	Spain	Barcelona
32	Sweden	Stockholm, Gothenburg, Milano
33	Switzerland	Basle, Zurich, Geneva
34	Taiwan	Taipei
35	U.A.E.	Dubai
36	U.K.	Landon (Heathrow), Newcastle, Oxford, Cheltham, Bristol, Wellingborough, Birmingham, East Midland, Manchester, Leeds, Glasgow.
37	U.S.A.	Newyork, Chicago, Sanfrancisco, Los Angeles, Atlanta
38	Ukraine	Kiev

ANNEXURE-D

PERFORMANCE BANK GUARANTEE
(FOR FOREIGN PURCHASE ORDERS)

BANK NAME AND ADDRESS

Bharat Heavy Electricals Limited (BHEL),
Electronics Division,
PB No. 2606,
Mysore Road,
BANGALORE- 560 026
INDIA

Dear Sir,

Ref: CONTRACT PERFORMANCE GUARANTEE.

WHEREAS you have entered into a contract reference No PO NO. _____ with M/s _____ having its registered office at _____ for the supply of _____ as detailed in your purchase order No. _____ which is hereinafter referred to as "the said contract" and WHEREAS M/s _____ has undertaken to produce a Bank Guarantee for 10% (Ten Percent) of _____ the contract price amounting to _____ (_____) to secure its obligations to Electronics Division, BHEL having its registered office at New Delhi for the performance of the contract including the warranty of the equipment supplied, We _____ Bank, _____ hereby expressly, irrevocably and unreservedly undertake and guarantee as principal obligors on behalf of M/s _____ that in the event Bharat Heavy Electricals Ltd. (B.H.E.L.) declares to us in writing that M/s _____ has not fulfilled any obligation according to the contractual obligation of the said contract, to pay you on demand and without demur to Bharat Heavy Electricals Ltd., Electronics Division , Mysore Road, P.B.No. 2606, Bangalore-560 026, India an amount of _____ (in words _____) subject to as may be determined below:

- 1) Notwithstanding any right M/s. _____ may have directly against you or any disputes raised by M/s _____, Your written demand shall be conclusive evidence to us that repayment is due under the terms of the said contract and shall be binding on us.
- 2) We shall not be discharged or released from this undertaking and Guarantee by any arrangements, variations made between you and M/s. _____ with or without our consent and Knowledge or by any alterations in the obligations of M/s. _____ by any forbearance whether as to payment, time, performance or otherwise.
- 3) This guarantee shall remain valid until the end of twenty-four weeks after the close of the warranty period or until the same is reported by BHEL to us whichever is earlier.

- 4) We agree and undertake not to revoke this guarantee during its validity unless discharged in writing by you subject to the provision of clause (7) below.
- 5) This guarantee shall be a continuing guarantee subject to the foregoing and shall not be discharged by any change in the constitution of the Bank or M/s.
_____.
- 6) This guarantee shall be governed by and constructed in accordance with the Laws of India.
- 7) At any time _____ Bank may render this guarantee null and void by paying to Bharat Heavy Electricals Ltd. the full amount being _____
(in _____ words _____)

For and on behalf of Bank
by its Authorised Signatory

Note:

- (1) To be executed in INR 100 Non-Judicial stamp paper by any authorized Indian Bank.
- (2) To be submitted directly by banker to concerned executive in purchase dept., Please give BHEL address to banker.
- (3) Do not enclose with Bank document.
- (4) Any Modification & omissions to this are not permitted

ANNEXURE - E

PERFORMANCE BANK GUARANTEE
(FOR INDEGENOUS PURCHASE ORDERS)

THIS DEED OF GUARANTEE made and executed on the _____ day of _____(year), by the _____ (Bank), registered under the Companies Act 1956/Nationalised Bank constituted under the Banking Companies (acquisition and transfer of undertakings) Act constituted under the State Bank of India Act / Subsidiary Banks Act, having its registered / head office at _____ represented herein by its Branch Manager / authorised representative Sri. _____ & Sri. _____(Hereinafter called 'guarantor ' which term shall mean and include its successors and assigns)

IN FAVOUR OF BHARAT HEAVY ELECTRICALS LIMITED

_____ (Buyer's Name), a company registered under the companies Act, 1956 having its registered office at BHEL House at Siri Fort , New Delhi-100 049 and its Electronics Division at Mysore road, Bangalore-26 (hereinafter referred to as the 'Company' Which term shall include its successors and assigns):

Whereas the company has placed an order on _____ (State the name of the company / firm and its address) (hereinafter referred to as the 'Supplier' which term shall mean and include its liquidators, successors and assign) for the supply of system under order / Contract No _____ Dt _____.

AND WHEREAS the supplier has agreed to supply the materials and carryout the works as detailed and in accordance with the terms set out in the said order/contract.

AND WHEREAS the company is not required to pay to the supplier a sum of Rupees _____being the 10% of the value of the goods supplied / Works performed / Services rendered under the said order / contract between the supplier and the company, till the company is satisfied with the mechanical Warranties and the performance standards stipulated in the said order / contract between the company and the supplier has been duly fulfilled, except against a Bank Guarantee for the said sum of Rs _____ in favour of the company by reputed Bank, in which case the company has agreed to make payment to the supplier of the said sum of Rupees _____ being (...%) of the value of the goods supplied / Works performed / Services rendered under the agreement between the supplier and the company and the Guarantor has at the request of the supplier, agreed to furnish this Guarantee subject to the terms and conditions stated below:

NOW THIS DEED WITNESSES THAT IN pursuance of the above said agreement, the guarantor hereby agrees and covenants With company is as follows :-

- 1) That during the period this contract of Guarantee remains effectual, the guarantor shall be liable in respect of the amount due and owing to the company in respect of the payments to the extent of Rs _____ (in words) _____ against any loss or damage caused to or suffered by the company by reasons of any breach of the terms of the said order / contract / Agreement by the supplier.
- 2) The Guarantor hereby undertakes to pay the amounts due and payable under this guarantee without any demur, merely on demand from the company intimating that the amount claimed is due by way of loss or damage caused to or suffered or would be caused or suffered by the supplier of any terms contained in the said order / contract. Any such demand made on the

guarantor shall be conclusive as regards the amount due and payable by the Guarantor irrespective of the fact whether the Contractor / supplier admits or denies.

- 3) The Guarantor further agrees that the agreement herein contained shall remain in force and effect till all the supplies to be made / Works to be performed / Services to be rendered under the said order / contract / agreement are completed to the entire satisfaction of the company or till company certifies that the terms and conditions of the said order / contract / agreement have been fully and properly carried out by the said supplier and accordingly discharges the Guarantee. Unless a demand or claim under this guarantee is made on the guarantor in writing on or before the expiry of claim period indicated in clause 6 below , the guarantor shall be discharged from all the liability under this guarantee thereafter.
- 4) The guarantor further agrees with the company that the company shall have the fullest liberty without the consent of the guarantor and without effecting in any manner the obligations of the guarantor hereunder to vary any of the terms of the said order / contract / agreement or extend the time of performance by the said supplier from time to time or refrain from exercising the power exercisable by the company against the said supplier or to forebear or omit to enforce any of the terms and conditions relating to the said order / contract / agreement, and the guarantor shall not be relieved of its liability in whole or in part , by reason of any act, commission or forbearance on the part of the company or by reason of any such variation, or extension being granted to the said supplier or by reason of any such matter or thing whatsoever which under the law relating to sureties would but for this provision have effect of so relieving the guarantor.
- 5) The guarantor undertakes not to revoke this guarantee during its currency except with the previous consent of the company in writing.
- 6) Notwithstanding anything herein above contained, the liability of the guarantor under these presents is restricted to Rs_____. The guarantee shall be in force till its expiry on _____ unless a demand is made on the guarantor within SIX months from the date of expiry, all the liability of the guarantor under this guarantee shall stand fully discharged. The decision of the claimant in regard to breach of contract is final and binding on the Bank.

IN WITNESS whereof, the guarantor, acting through it authorised representative has executed this deed of Guarantee on the day, month and year first above written.

(Seal of the Bank to be affixed)

WITNESS

1.

2.

ANNEXURE - F

BHEL MEMBER BANKS

PBG SHALL BE ISSUED FROM THE FOLLOWING BANKS OR THEIR BRANCH OFFICES ONLY

State Bank of India, CAG Branch 10 th Floor, Vijaya Building Barakamba Road, NEW DELHI - 110 001	Deutsche Bank, Tolstoy Marg, NEW DELHI - 110 001
Canara Bank, 74, Janpath, NEW DELHI - 110 001	HDFC Bank Ltd, 5 TH floor, H T House, K G Marg, , NEW DELHI - 110 001
Punjab National Bank, 74 Janpath, NEW DELHI - 110 001	CITI Bank NA, Jeevan Vihar Building, Sansad Marg NEW DELHI - 110 001
Bank of Baroda, Corporation Banking Branch, 11 th Floor, BOB Building, Sansad Marg, NEW DELHI - 110 001	Standard Chartered Bank, H2, Block Connaught Place NEW DELHI - 110 001
State Bank of Hyderabad, Surya Kiran Building, K G Marg, NEW DELHI - 110 001	ICICI Bank Ltd, ICICI Tower, Bisham Pitamah Marg, Pragati Vihar, NEW DELHI - 110 003
State \Bank of Mysore, Antrikash Bhawan, K G Marg, NEW DELHI - 110 001	IDBI Bank Ltd, 19 K G Marg, Surya Kiran Building, NEW DELHI - 110 001
State Bank of Mysore, Industrial Finance Branch, 18, Ramanashree Arcade,, M G Road, BANGALORE 0 560 001	HSBC Ltd, ECE House, 28K G Marg, NEW DELHI - 110 001
State Bank of Travancore, Travancore House, IF Branch, NEW DELHI - 110 001	
