

FIRST ANGLE PROJECTION (ALL DIMENSIONS IN mm.)

FORM DG 44(B)

B2-64 INVENTORY No. SIGN. & DATE REF. DRG. No. COPYRIGHT AND CONFIDENTIAL THE INFORMATION ON THIS DOCUMENT IS THE PROPERTY OF BHARAT HEAVY ELECTRICALS LIMITED. IT MUST NOT BE USED DIRECTLY OR INDIRECTLY IN WAY DETERIMENTAL TO THE INTEREST OF THE COMPANY.

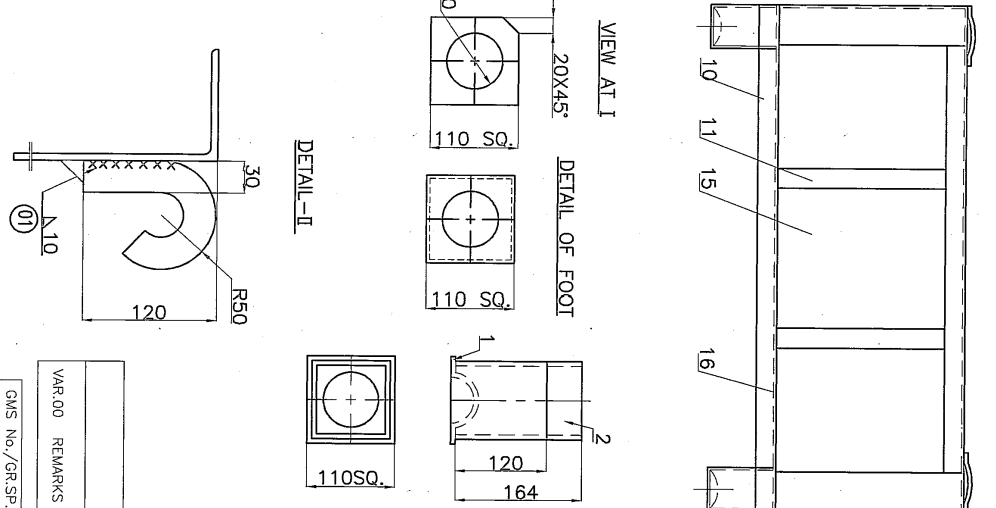
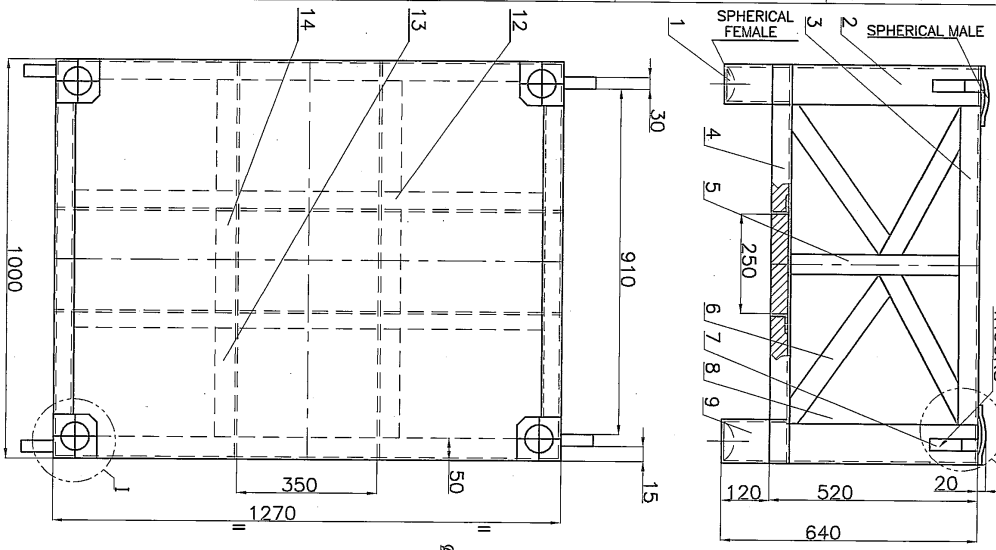

- NOTES**
1. PALLETS WILL BE STACKED ONE ON THE OTHER, MALE AND FEMALE CAP SHOULD BE PERFECTLY ALIGNED FOR STACKING PURPOSE.
 2. BOX IS CLOSED FROM 3 SIDES BY 2MM. THICK SHEET.
 3. PALLET TO BE PAINTED WITH 2COATS OF RED OXIDE AND 2 COATS OF SATIN BLUE ENAMEL PAINT.
 4. REFER PLANT STD. HW 0850199 PART-2 FOR D.P. TEST OF WELD JOINTS AT HOOK PORTIONS.

SHEET	ITEM No.	DESCRIPTION	VAR. NO.	REMARKS
16	1	CAP ISPL 110X110X6		
15	2	ANGLE ISA 50X50X6		
14	3	ANGLE ISA 50X50X6		
13	4	ANGLE ISA 50X50X6		
12	5	ANGLE ISA 50X50X6		
11	6	FLAT ISF 50X6		
10	7	FLAT ISF 50X6		
9	8	CHANNEL ISMC 100X50X6		
8	9	HOOK FROM 30MM PLATE		
7	10	FLAT ISF 50X6		
6	11	FLAT ISF 50X6		
5	12	FLAT ISF 50X6		
4	13	ANGLE ISA 50X50X6		
3	14	ANGLE ISA 50X50X6		
2	15	ANGLE ISA 50X50X6		
1	16	SHEET 1255X985X3.15		

GRADE OF UNTOI DIM. :-
M/GC-C/M/F AA0230208
WELDING-A/B/C/D-AA0621104
GAS CUTTING-T3/AA0621101

REV. DATE ALTERED RRS
01 15/01/07 CHECKED SIB

JTE/D/2007/002

DEPT. NAME SIGN. DATE
JTE/JTE

STATUS OF PRODUCT
SHOP ACCESSORY

COMP. DRG. No. MODEL No. REF. DRG. No.

NAME SIGN. DATE
BHARAT HEAVY ELECTRICALS LTD. Sd/- 22.6.08

SCALE 1:8 WEIGHT(KGS) 159.0

DRAWING No. JTD/SK/0476

SHEET No. 01 No. OF SHEET 01

8 7 6 5

14 13 12 11 10 9 8 7 6 5

1000 1270 910 150 120 50 350 15

1 2 3 4 5 6 7 8 9 10 11 12 13 14 15 16

SPHERICAL FEMALE SPHERICAL MALE

4HOOKS

VIEW AT I

DETAIL OF FOOT

DETAIL - II