



Bharat Heavy Electricals Limited

(High Pressure Boiler Plant)

Tiruchirappalli – 620014, TAMIL NADU, INDIA

An ISO 9001
Company

CAPITAL PURCHASE / MATERIALS MANAGEMENT / MANUFACTURING

ENQUIRY	Phone: +91 431 257 79 38 Fax : +91 431 252 07 19 Email : tvenkat@bheltry.co.in Web : www.bhel.com
----------------	---

	Enquiry Number:	Enquiry Date:	Due date for submission of quotation:
	2620700067	09.08.2007	24.09.2007

Your are requested to quote the Enquiry number date and due date in all your correspondences. This is only a request for quotation and not an order

Item	Description	Quantity	Delivery (Item required at BHEL on)
10	3 Ton Semi Gantry Crane Span 14000mm Lift 5600mm as per the technical specification & commercial conditions applicable (to be downloaded from web site www.bhel.com or http://tenders.gov.in)	4 Nos.	30.09.2008
20	3 Ton Semi Gantry Crane Span 11000mm Lift 3500mm as per the technical specification & commercial conditions applicable (to be downloaded from web site www.bhel.com or http://tenders.gov.in)	4 Nos.	30.12.2008
30	3 Ton Semi Gantry Crane Span 11000mm Lift 5600mm as per the technical specification & commercial conditions applicable (to be downloaded from web site www.bhel.com or http://tenders.gov.in)	4 Nos.	30.11.2008
40	3 Ton Semi Gantry Crane Span 14000mm Lift 3500mm as per the technical specification & commercial conditions applicable (to be downloaded from web site www.bhel.com or http://tenders.gov.in)	3 Nos.	30.10.2008

Note:- The technical specifications (Part – A & Part – B) are common for all the above four items.

BHEL commercial terms & conditions with Price Bid and Bank Guarantee formats along with technical specifications can be downloaded from BHEL web site <http://www.bhel.com> or from the Government tender website <http://tenders.gov.in> (public sector units > Bharat Heavy Electricals Limited page) under Enquiry reference “2620700067”.

Tenders should reach us before 14:00 hours on the due date Tenders will be opened at 14:30 hours on the due date Tenders would be opened in presence of the tenderers who have submitted their offers and who may like to be present	Yours faithfully, For BHARAT HEAVY ELECTRICALS LIMITED Manager / Capital Purchase / MM / Manufacturing
--	--

PART A**SECTION-I: -QUALIFYING CRITERIA**

The BIDDER/VENDOR (OEM) has to compulsorily meet the following requirements to get qualified for consideration of the technical offer for the SUPPLY OF SEMI-GANTRY CRANE

S. No.	PARTICULARS	VENDOR'S RESPONSE
1.0	<p>Only those Bidder/vendor (OEM), who have supplied and commissioned at least ONE 3 Ton capacity double box girder Semi-gantry crane class-3 with frequency converter drive and minimum span of 11 Mtr or higher and such crane is presently working satisfactorily for more than one year after commissioning (on the date of opening of Tender), should quote.</p> <p>However, if such crane has been supplied to BHEL, then it should be presently working satisfactorily for more than six months after its commissioning and acceptance (on the date of opening of Tender) in BHEL.</p> <p>Performance certificate from the customers (minimum 2) regarding satisfactory performance of machine supplied to them in attached format should be enclosed along with technical offer.</p>	
2.0	BHEL reserves the right to verify the information provided by vendor. In case the information provided by vendor is found to be false/ incorrect, the offer shall be rejected.	
3.0	The bidding FIRM should have 'in-house' or 'self-owned' facility for FABRICATION and TESTING at 125 % of the rated capacity	
4.0	The vendor should have minimum 5 years experience in design, fabrication and supply of cranes.	

SECTION – II

The vendors are requested to provide the following details

S. No.	PARTICULARS	VENDOR'S RESPONSE
3.0	Number of Years of Experience of the BIDDER/VENDOR (OEM) in the field of design, manufacture,	

	supply, erection & commissioning of cranes	
4.0	Number of cranes supplied, installed and commissioned till date	
5.0	Number of cranes supplied, installed and commissioned till date in the QUOTED MODEL	
6.0	Number of cranes supplied, installed and commissioned till date for the following category of CUSTOMERS a) Power Utility Boiler Manufacturer b) Equipment Supplier for Process Industries [Heavy Engineering Companies] c) Research Establishments	
7.0	Details on SERVICE-AFTER-SALES Set-Up in India including the Addresses of Agents / Service Centre in India and Asia	
8.0	Any Additional Data to supplement the manufacturing capability of the BIDDER for the subject equipment.	

SECTION – III

Bidder / Vendor (OEM) to note the following

S.No.	REQUIREMENTS	VENDOR'S RESPONSE
9.0	The BIDDER / VENDOR shall submit the offer in TWO PARTS - Technical [with PART A & PART B] & Commercial and Price Bid.	
10.0	The Offer shall contain a comparative statement of Technical Specifications given by BHEL and the Offer Details submitted by the Bidder, against each clause. Where details are required, a mere 'CONFIRMED' or 'COMPLIES' or 'YES' or 'NO-DEVIATION' or similar words in the technical comparative statement may lead to disqualification of the Technical Offer.	
11.0	The Technical Offer shall be supported by Product Catalogue and Data Sheets in ORIGINAL and complete technical details of 'Bought-Out-Items' with copies of Product Catalogue and Selection Criteria	
12.0	The Commercial Offer (given with the Technical Offer) shall contain the Scope of Supply and the Un-Priced Part of the Price-Bid, for confirmation	
13.0	BIDDER has to indicate the Country of Origin for the supply of equipment.	

PERFORMANCE CERTIFICATE

(On Customer's Letter Head)

1. Supplier of the Equipment :

2. Make & Model of the Equipment :

3. Month & Year of Commissioning :

4. Application :

5.
 - a) Crane Type:

 - b) Crane Capacity (Metric Tonnes):

 - c) Crane span :

 - d) Mechanism class :

6. Performance of the Equipment : Best in the market /
(Strike off whichever is not applicable) Satisfactory /
Good /
Average /
Not Satisfactory

7. Any other remarks:

Date:

Signature & Seal of the Authority
Issuing the Performance Certificate

PART B.**TECHNICAL SPECIFICATIONS FOR 3 TON SEMI – GANTRY CRANE**

S.No.	PARTICULARS	BHEL SPECIFICATIONS	VENDOR's TECHNICAL OFFER (With Complete Details)
1.0.0	APPLICATION	a. The subject crane is meant for the purpose of handling small to medium (within the lifting capacity of the crane) components, in a heavy and large steel fabrication shopfloor. b. The crane will be put to use for 365 Days' continuous duty with CT, LT and Hoist movements, which may occur simultaneously (within the operating parameters specified under Clause Nos. – 3.1.0, 3.4.0 and 3.5.0). c. The shopfloor environment will be dust prone, humid, welding fume filled and ambient temperature going upto 60 to 65 ° C. , due to pre-heating of jobs.	
2.0.0	SCOPE OF SUPPLY	a. Basic Design as per the Tender Specifications given under PART-B b. Detailed Design and Manufacture as per BHEL GENERAL SPECIFICATIONS, given as ANNEXURE-1 . c. Assembly and Testing before Despatch d. Supply in Modules / Sub-Assemblies e. Commissioning and Performance Prove-Out at BHEL Works f. Performance Guarantee for 12 months, from the date of commissioning.	<u>SPECIAL NOTE to BIDDER :</u> <i>The SUPPLIER has to abide by the clauses applicable for selection of materials and crane construction, and those clauses irrelevant for semi-gantry crane manufacture may be ignored.</i>

S.No.	PARTICULARS	BHEL SPECIFICATIONS	VENDOR's TECHNICAL OFFER (With Complete Details)
3.0.0	TECHNICAL SPECIFICATIONS		
3.1.0	CAPACITY	Lifting Capacity	
3.1.1	Main Hoist	3 Metric Tonnes	
3.1.2	Auxiliary Hoist	NO AUXILIARY HOIST	
3.2.0	SPAN	Wheel Centre to Wheel Centre Dimension	
3.2.1	Long Travel Span / Ht. Of lift	1. 14000mm / 5600mm 2. 14000mm / 3500mm 3. 11000mm / 5600mm 4. 11000mm / 3500mm [Capacity & Lift of Hoist]	Rate may be quoted for each item separately.
3.2.2	CT Span	1600 mm	
3.3.0	Lift of hoist	Actual lift	
3.3.1	Height of Lift	As above	
3.3.2	Rail to Rail Height	1. 5600 mm 2. 3500 mm 3. 5600 mm 4. 3500 mm (Rail on the Floor to Rail on Side Bracket)	
3.4.0	DUTY CYCLE	Related to Drive Motor & Mechanisms	
3.4.1	Hoists	40 % E D	
3.4.2	Long Travel	40 % E D	
3.4.3	Cross Travel	40 % E D	
3.5.0	SPEED	Operating / Working Speed [Maximum]	
3.5.1	Main Hoist	5.0 mtrs./minute.	
3.5.2	Cross Travel (CT)	15.0 mtrs./minute.	
3.5.3	Long Travel (LT)	30.0 mtrs./minute.	
3.6.0	MOTOR RATINGS	Electric Drive Motor Ratings & Frame Sizes	
3.6.1	Main Hoist	5.0 kW ; Frame Size – 160 M / 6 Pole	
3.6.2	Cross Travel (CT)	2.0 kW ; Frame Size – 112 M / 6 Pole	
3.6.3	Long Travel (LT)	2 x 3.0 kW ; Frame Size – 132 M / 6 Pole	

3.7.0	GEAR BOX	Gear Box Sizes	
S.No.	PARTICULARS	BHEL SPECIFICATIONS	VENDOR's TECHNICAL OFFER (With Complete Details)
3.7.1	Main Hoist	HR 450 mm	
3.7.2	Cross Travel (CT)	VR 270 mm	
3.7.3	Long Travel (LT)	VR 400 mm	
3.8.0	Hoist rope	Dia. 10 mm ; Falls - 4	
3.9.0	CONTROL	Cabin Operation Only	
3.10.0	Type of Control	Master Control	
3.11.0	Control Voltage	110 V AC	
3.12.0	Input Power Supply	415 ± 10% Volts , 50 ± 3% Hz, 3 Phase- AC	
3.13.0	Duty Class	Class – 3 [Indoor Service]	
3.14.0	Mechanism Group Classification	M 6	
3.15.0	DESIGN STANDARD	IS – 807 & 3177 / 1999	
3.16.0	Runway Rail Size		
3.16.1	Cross Travel (CT)	ISR 60 Lbs./Yard	
3.16.2	Long Travel (LT)	ISR 90 Lbs./Yard	
3.17.0	Wheel Size		
3.17.1	Cross Travel (CT)	250 mm	
3.17.2	Long Travel (LT)	400 mm	
3.18.0	Brake Drum Size	Hoist Brake Drum Sizes	
3.18.1	Hoist	200 mm	
3.18.2	Cross Travel (CT)	100 mm	
3.18.3	Long Travel (LT)	160 mm	
4.0.0	MAIN FEATURES	Crane Operational Features	
4.1.0	Control System	Frequency Converter type for all motions	
4.2.0	Crane Operation	From Cabin with Push Button operation	

S.No.	PARTICULARS	BHEL SPECIFICATIONS	VENDOR's TECHNICAL OFFER (With Complete Details)
5.0.0	STRUCTURAL FABRICATION	Crane Structure Constructional Details	
5.1.0	Bridge / Girder	Double girder Box type Construction for Girders	
5.2.0	Raw Material	Only steel plates, tested and certified for quality by reputed inspection authorities, shall be used.	
5.3.0	Welded Joints	To be followed for Girder Fabrication	
5.3.1	Number of Joints	Maximum Two Joints only allowed	
5.3.2	Welding Electrodes	a. For all Horizontal Welding E 7018 Electrode only should be used. b. For all Vertical Welding E 7048 Electrode only should be used.	
5.3.3	Welded Joint Testing	All Butt Welded Joints (both compression / tension and flanges / web joints) shall be subjected to 100% X-Ray Testing and X-Ray Films to be produced for BHEL evaluation and form part of the documentation.	
5.4.0	Splice Joints	NO SPLICE JOINT IS ALLOWED IN GIRDER FABRICATION [Girder shall be of SINGLE PIECE only].	
5.5.0	Platform on Girders	The Platforms provided on both the Girders shall be fixed through BOLTED JOINTS only.	
5.6.0	Heat Treatment & NDT Examination	The Fabricated Trolleys shall be Stress Relieved, if necessary, by thermal heat-treatment process after welding & NDT. All welding shall be tested by NDT means [MPI, LPI & RT] after Stress Relieving operation.	

S.No.	PARTICULARS	BHEL SPECIFICATIONS	VENDOR'S TECHNICAL OFFER (With Complete Details)
5.7.0	Wheel Assembly	The Wheel Assembly coming for Cross Travel (CT) and Long Travel (LT) shall be of LIVE AXLE SYSTEM with L-Type Bearings. [Refer to BHEL Drawing No. 3-M-02R-0011993 for the Wheel Assembly Details. Drg. Dimensions are to be strictly followed for the manufacture. Drg. enclosed and given as ANNEXURE -2].	
5.8.0	Machining Operation	All mechanical mating surfaces and wheel seating areas are to be machined to the required finish and protected	
5.9.0	Surface Cleaning	Both the Girders and the Trolleys are to be shot blasted or chemically treated for surface cleaning, after completion of all operations but prior to painting.	
5.10.0	Painting	The crane parts are to be painted as follows : a. One coat of Primer with 25 μ of DFT (Dry Film Thickness) and 48 hours of compulsory curing after painting. b. Two coats of Enamel Paint (Colour – International Tractor Orange) each with a DFT of 25 μ and intermittent curing of 16 hours.	
6.0.0	MECHANICAL ELEMENTS		
6.1.0	Gears	Gears in all the Stages shall be helical in design and to be of machined, lapped and hardened if required.	
6.2.0	Gear Box Casing	Shall be of fabricated type and stress relieved by thermal heat-treatment process, prior to machining.	

S.No.	PARTICULARS	BHEL SPECIFICATIONS	VENDOR'S TECHNICAL OFFER (With Complete Details)
6.3.0	Rope Drum	Shall be of fabricated type and stress relieved. The circumferential weld joints shall be tested by 100 % X-Ray for quality assurance.	
6.4.0	Type of Coupling	Only GEARED COUPLING to be used a. between Electric Motor and Gear Box b. between Gear Box and Rope Drum c. between Gear Box and Trolley Wheels	
6.5.0	Wheels	Wheels shall be of Forged and Wheel Tread hardened to 300/350 BHN. Wheels shall be fitted with L-Type Bearings	
6.6.0	Mechanical Joints	Fit Bolts (as per IS 3640 –1982) for all joints coming in main members	
6.7.0	Pulley Dimension	Rope Pulley diameter shall be 23 times that of Rope diameter	
6.8.0	Lifting Hook	Hook Latch shall be provided for the Hook	
6.9.0	Limit Switches	Hoist shall be provided with Rotary and Counter-Weight limit Switches	
7.0.0	ELECTRICAL ELEMENTS		
7.1.0	Operational Controls	The Crane shall be provided with the Cabin Control [Master Control] - Push Button Type	
7.2.0	Control Voltage	110 V AC	
7.3.0	Type of Brakes	a. Hoist - Thruster Brake b. Cross Travel - Thruster Brake c. Long Travel - Thruster Brake	

S.No.	PARTICULARS	BHEL SPECIFICATIONS	VENDOR'S TECHNICAL OFFER (With Complete Details)
7.4.0	Protection	All Panels, Limit-Switches and Motors shall have IP 54 protection.	
7.5.0	Electric Motors	All Electric Motors shall be as per IS-325 and IS-1231.	
7.6.0	Electric Contactors	All Panels shall have only SIEMENS Contactors and shall be suitable for AC3 Duty Class.	
7.7.0	Contactors Rating	The rating of all Contactors shall be atleast 50% higher than the respective electric motor full load current, at the specified duty cycle.	
7.8.0	Electrical Design	All Electrical Elements shall be so selected, that they withstand 25% overloading of the crane, at any time of operation.	
7.9.0	Long Travel Motion	A Dual Drive Mechanism shall be provided for LT (Long Travel) Motion.	
7.10.0	Control Steps	A 4-Step Control has to be provided for a. Main Hoist b. Long Travel c. Cross Travel	
8.0.0	SELECTION of BOI and COMPONENTS	The makes of Components or Bought-Out-Items shall be strictly as per the list given below.	
8.1.0	Hoist Hooks	HERMAN MOHTTA / HERCULES / SILPA UDYOG / SMRITI FORGINGS / KARACHIWALA	
8.2.0	Wire Rope	USHA MARTIN / FORT WILLIAM / RA WIRE ROPE	

S.No.	PARTICULARS	BHEL SPECIFICATIONS	VENDOR's TECHNICAL OFFER (With Complete Details)
8.3.0	Electric Motors	GEC / BHARAT BIJLEE / SIEMENS / KEC	
8.4.0	Thruster Brake Unit	ELECTROMAG / SPEED-O-CONTROL / OMEGA	
8.5.0	Limit Switch (Gravity Type)	SIEMENS / INDUSTRIAL SYNDICATE / BCH / SKC / SOC	
8.6.0	Contactors	Only SIEMENS make	
8.7.0	Over-Load-Relay	SIEMENS (THERMAL TYPE)	
8.8.0	HRC Fuses	ENGLISH ELECTRIC / L&T /SIEMENS	
8.9.0	Rotary limit switch	SIEMENS / OMEGA / SOC / INDUSTRIAL SYNDICATE	
8.10.0	Resistance box	Stromkraft / BCH / Ohmark	
8.11.0	Switch fuse unit	ENGLISH ELECTRIC / SIEMENS / GEC	
8.12.0	Moulded Case C.B	SIEMENS / L&T	
8.13.0	Pneumatic Time Delay	Only BCH make	
8.14.0	Push - Buttons	SIEMENS / L&T /AIRON	
8.15.0	Connectors	Only ELMAX make	
8.16.0	Couplings	WMI / FENNER / ALFEX	
8.17.0	Bearings	SKF / NBC / ZKL	
8.18.0	Cables	Reputed Makes & ISI Approved	
8.19.0	VVVF Drives	ABB / SIEMENS / L&T	
8.20.0	[Other Elements]	[Bidder to Specify Item and Makes]	[For Additional Details]

S.No.	PARTICULARS	BHEL SPECIFICATIONS	VENDOR's OFFER
9.0.0	DOCUMENTS/DETAILS for APPROVAL	The following documents and details are to be submitted for BHEL Approval, prior to taking up the manufacture of the crane.	
9.1.0	Drawings and Documents	<ul style="list-style-type: none"> a. GA Drawing of the Crane. b. GA Drawing of Crab with Trolley c. GA Drawing of Individual Mechanisms. d. Drawings of Bridge, End-Carriage, Leg and their connection. e. Sub-Assembly Drawing for Wheels, Hook Blocks, Gear Boxes & Hoist Drums. f. Calculations for Selection of Electric Motors, Gear Reducers, Brakes, Couplings, etc. g. Calculations for Bridge Girder, Crab, End - Carriage and their connections. h. Wiring Diagram with Logic Circuits. i. Cable Selection based on Current Rating. 	
9.2.0	Technical Details	<ul style="list-style-type: none"> a. Total Weight of the Crane including all Electrical Equipment b. Total Weight of Trolley including all Electrical Equipment c. Weight of each Bridge assembled and ready for erection with and without Mechanical and Electrical Equipment. d. Weight of each End - Carriage assembled and ready for erection e. Total Weight of Structural, Mechanical and Electrical Equipment and indicated separately also. 	

S.No.	PARTICULARS	BHEL SPECIFICATIONS	VENDOR's OFFER
10.0.0	INSPECTION	The following Schedule of Stage Inspections is to be strictly adhered to, prior to dispatch from the Supplier's Works	
10.1.0	STAGE – I	<ul style="list-style-type: none"> a. Verification of Test Certificate for Raw Materials used for Girders, End-Carriages, Trolleys, Gear Box Casings, etc. b. Verification of X-Ray Report of Butt-Joints coming in the Girders and Random Testing on the Welds, by physical examination. c. Box Girder setting before closing of the Bottom Flanges – for inspecting the quality of welding and presence of waviness d. Trolley Frame Fabrication before setting the Mechanisms e. End – Carriage Fabrication 	
10.2.0	STAGE – II	<ul style="list-style-type: none"> a. Inspection of Bridges and End – Carriages with Wheel Assembly and Alignment checking b. Verification of Span & Diagonal Dimensions, Checking of Wheel Alignment, Mechanical Assemblies and Total Alignment. c. Free running of the all the Mechanisms. 	
10.3.0	STAGE – III [Final Inspection]	<ul style="list-style-type: none"> a. Measurement of CAMBER in the Bridges. b. Full / Rated Load Test and Deflection Test. c. Deflection and Permanent Set Measurement. d. 25% OVER-LOAD Lifting Ability Check. 	

S.No.	PARTICULARS	BHEL SPECIFICATIONS	VENDOR's OFFER
11.0.0	CRANE ERECTION & COMMISSIONING		
11.1.0	Mechanical Erection	Erection of the Crane will be done by BHEL, as per the guidelines furnished in the Erection Manual given by the Supplier	
11.2.0	Crane Commissioning	Commissioning of the Crane and Performance Prove –Out for the Crane's Capacity and Smooth Functioning of the Crane (at BHEL Works) shall be the RESPONSIBILITY of the supplier.	
12.0.0	O & M MANUALS	Each Crane shall be provided with THREE Copies of Erection, Operation & Maintenance Manual, containing the following technical details	
12.1.0	Drawings & Details	<ul style="list-style-type: none"> a. Crane GA Drawing b. Crab Assembly Drawing c. Total Crane Wiring Schematics d. Detailed Wiring Diagrams for Sub-Systems / Panels e. Wheel Assembly Drawings f. Bottom Block Assembly Drawing g. Gear Box Assembly Drawings h. Coupling Drawing and Details i. Specifications/Ratings of All Bought-Out-Items j. Warranty / Guarantee Card for all Bought-Out-Items k. Trouble Shooting Chart for Main and all Sub-Systems 	
13.0.0	PERFORMANCE GUARANTEE	The Performance of the Total Crane and/or the Components / Sub-Assemblies / Bought-Out-Items shall be guaranteed for a minimum period of twelve months from the date of performance acceptance at BHEL Works.	

THIS DRAWING IS OUR SOLE PROPERTY AND SHOULD NOT BE USED IN ANY FORM FOR ANY PURPOSE WITHOUT THE WRITTEN PERMISSION OF BHARAT HEAVY ELECTRICALS LIMITED TRICHIRAPPALLI - 620 014.

ALL DIMENSIONS ARE IN MM

SL. No.	W.D. (WHEEL DIA) IN MM	RAIL SIZE	A	B	D	E	F	ØG	H	ØJ	K	L	Ød	M (KEY)	N	P	Q	S	R	COUPLING No.	SKF BRG No. & BRG. SIZE	TOTAL WEIGHT IN Kg. FOR DRIVE & IDLE
16	800/850	CR-100 CR-120	190	450	80	210	150	152	140	130	212	255	32	32x18x130	687	588	20	150	80	107	22330 150x320x108	870.00 845.00
15		CR-80	168	420	80	180	110	152	125	110	212	255	32	28x16x115	687	588	20	150	80	106	22330 150x320x108	796.00 775.00
14		CR-100 CR-120	190	450	80	210	150	152	140	130	212	255	32	32x18x130	642	588	20	150	80	107	22330 150x320x108	808.00 784.00
13	710/750	CR-100 CR-120	180	420	71	210	150	132	125	110	180	224	32	28x16x115	607	517	20	130	80	106	22326 130x280x93	728.50 711.50
12		CR-80	180	400	71	180	110	132	125	110	180	224	32	28x16x115	607	517	20	130	80	106	22326 130x280x93	653.00 636.00
11	630/680	CR-80/CR-100 & CR-120	180	420	71	210	150	132	125	110	180	224	32	28x16x115	567	517	20	130	80	106	22326 130x280x93	629.00 611.50
10		90-105 Lbs/Yd CR-80	150	365	60	180	105	111	110	90	160	190	26	25x14x100	547	462	20	120	60	105	22322 110x240x80	448.00 434.50
9		CR-80 CR-100	160	375	60	180	125	111	110	90	160	190	26	22x14x100	482	462	20	120	60	105	22322 110x240x80	253.00 245.50
8	500/550	CR-80	150	360	50	180	125	91	105	80	125	160	26	22x14x90	445	395	20	100	50	104	22318 90x190x64	389.00 378.00
7		60/75/90 & 105 Lbs/Yd	150	360	50	180	105	91	105	80	125	160	26	22x14x90	445	395	20	100	50	104	22318 90x190x64	301.00 294.00
6	400/450	CR-80 CR-100	150	360	50	180	125	91	105	80	125	160	26	22x14x90	395	395	20	100	50	104	22318 90x190x64	253.00 245.50
5		90 Lbs/Yd 105 Lbs/Yd	145	315	40	180	105	76	85	70	112	140	22	20x12x75	375	345	16	90	50	103	22315 75x160x55	197.00 192.00
4	320/370	75 / 90 & 105 Lbs/Yd CR-80	145	315	40	180	105	76	85	70	112	140	22	20x12x75	345	345	16	90	50	103	22315 75x160x55	162.00 157.00
3		50 SQ.BAR 60 Lbs/Yd 75 Lbs/Yd	112.5	260	40	125	85	61	65	55	85	112	17	16x10x55	312	287	16	80	50	102	22312 60x130x46	118.50 118.00
2	250/280	50 SQ.BAR 60 / 90 & 105 Lbs/Yd	105	250	32	125	85	61	65	55	76	100	17	16x10x55	254	249	12	60	40	102	22212 60x110x28	66.00 63.00
1	200/230	50 Lbs/Yd 50 SQ.BAR 60 Lbs/Yd	95	220	32	100	67	46	55	40	71	95	17	12x8x45	239	232	12	65	40	101	22309 45x100x36	51.00 50.00

DIMENSIONS

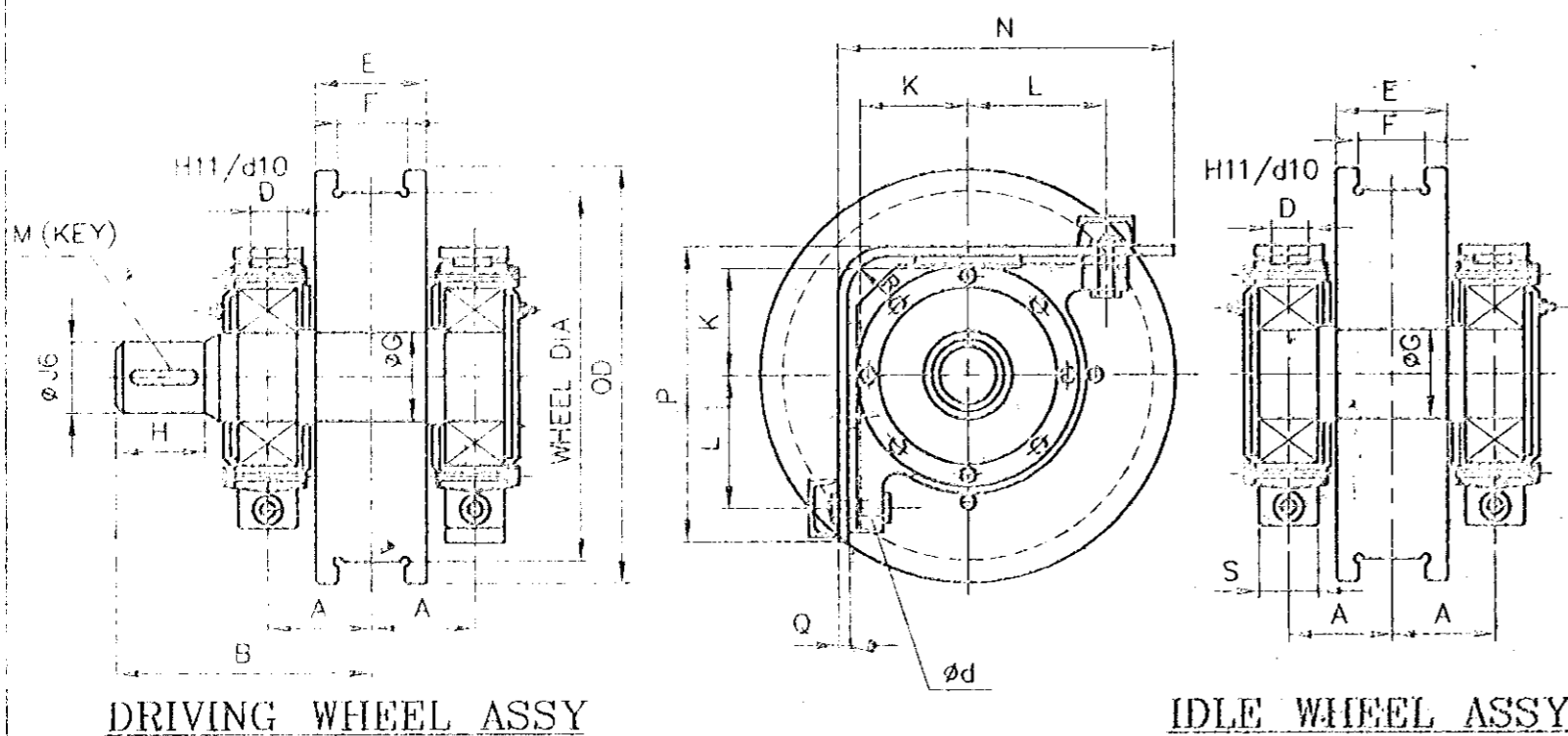

MATERIAL :- SHAFT - 45CB/IS:4283.
WHEEL - 55CB/IS:5517.
FORGED.
THREAD PORTION WHEEL HARDNESS 300 TO 350 (BHN)

No. of Pieces		DESCRIPTION	MATERIAL	STANDARD	NET.WT.IN KGS.	DRAWING No.	ITEM No.
REFERENCE				COMPONENT CODE: 29	EQUIPMENT CODE: 00		
SCALE		DRAWN	CHECKED	APPROVED	DATE	ALTERATIONS	DCN. REF
					20-10-2000		
MACHINE: CRANE WHEEL ASSY				TYPE: GENERAL			
TITLE: STANDARD CRANE WHEEL ASSY				DRAWING No. 3-M-02R-11993			
No. of Sheets				Sheet No.			