

# TENDER SPECIFICATION

NO: BHE/PW/PUR/SLT-CBL/538

FOR

HANDLING AT SITE STORES/STORAGE YARD, TRANSPORTATION TO SITE OF WORK, COMPLETE ERECTION, TESTING, COMMISSIONING AND HANDING OVER OF ELECTRICAL CABLING PACKAGE, EARTHING AND LIGHTNING PROTECTION SYSTEM AND ASSOCIATED ITEMS FOR UNIT #3&4 of 125 MW

AT

**GUJARAT INDUSTRIAL POWER COMPANY LIMITED**

EXPANSION OF SURAT LIGNITE POWER PLANT (SLPP)

NANI NAROLI, TALUKA-MANGROL

DISTT: SURAT, GUJARAT

**PART –I**

(TECHNICAL BID SPECIFICATION, NOTICE INVITING TENDER and GCC)



**BHARAT HEAVY ELECTRICALS LIMITED**  
(A GOVERNMENT OF INDIA UNDERTAKING)  
POWER SECTOR : WESTERN REGION  
345, KINGSWAY : NAGPUR 440 001

## Contents

SN	Description	Section/ Appendix No.	No. of Pages
1.	Tender Specification	--	1
2. 1	Project Information	--	1
3.	Procedure For Submission Of Sealed Tender	--	2
4.	Check List	--	2
5.	Declaration Sheet	--	1
6.	Certificate of <b>No Deviation</b>	--	1
7.	Notice Inviting Tender (Containing Qualifying Requirements)	-	\$
8.	General Conditions Of Contract	Section-1 & 2	\$
9.	Offer Of Contractor	Section-3	1
<b>Special Conditions of Contract</b>			
10.	Scope of Work	Section-4	24
11.	Obligations Of The Contractor (Tools, Tackles, Consumables etc.)	Section-5	6
12.	Contractor's Obligations in Regard to Employment of Supervisory Staff and Workmen	Section-6	2
13.	Obligations of BHEL	Section-7	1
14.	Inspection/Quality Assurance/Quality Control/Statutory Inspection	Section-8	3
15.	Safety, Occupational Health and Environmental Management	Section-9	12
16.	Drawings And Documents	Section-10	1
17.	Time Schedule/Mobilization/ Progress Monitoring/ Overrun.	Section-11	3
18.	Terms of Payment	Section-12	6
19.	Extra Charges for Modification/ Rectification	Section-13	2
20.	Insurance	Section-14	2
20	Earnest Money Deposit and Security Deposit	Section-15	2
21	Technical Details, Bill of Quantities & List of Drawings enclosed with Tender Specs.	Section-16	7

	<b>Appendices</b>		No. of Pages
22	LIST OF T&P TO BE PROVIDED BY BHEL	Appendix-I	1
23	List of Consumable to be Provided by BHEL	Appendix-II	1
24	Major T&P and MMD to be Deployed by the Contractor	Appendix-III	4
25	Month-wise Manpower Deployment Plan enclosed	Appendix-IV	1
26	Analysis of Unit Rates Quoted	Appendix-V	1
27	Contractor's T&P/MMD Deployment Plan	Appendix-VI	1
28	Details Of Concurrent Commitment	Appendix-VII	1
29	Detail of work done during last five years	Appendix-VIII	1
30	Rate Schedule (Price Bid : Part-II)	@	

#### LEGEND

§: Attached at the end of hard copy of Tender Specifications Part-I. Hosted in BHEL web page ([www.bhel.com](http://www.bhel.com)) as file titled “**NIT+GCC-538**”.

@: Issued as separate hard copy booklet ‘Tender Specifications Part-II (Price Bid)’. Hosted in BHEL web page ([www.bhel.com](http://www.bhel.com)) as files titled “**PRICE BID-538**” & “**Cover Pages Price Bid 538**”

#### **Note:**

Rest of the tender documents are included in Tender Specifications Part-I. Hosted in BHEL web page ([www.bhel.com](http://www.bhel.com)) as file titled “**TECH BID-538**”

# TENDER SPECIFICATION

NO: BHE/PW/PUR/SLT-CBL/538

FOR

HANDLING AT SITE STORES/STORAGE YARD, TRANSPORTATION TO SITE OF WORK, COMPLETE ERECTION, TESTING, COMMISSIONING AND HANDING OVER OF ELECTRICAL CABLING PACKAGES , EARTHING AND LIGHTNING PROTECTION SYSTEM AND ASSOCIATED ITEMS FOR UNIT #1&2 of 125 MW

AT

**GUJARAT INDUSTRIAL POWER COMPANY LIMITED**

EXPANSION OF SURAT LIGNITE POWER PLANT (SLPP)

NANI NAROLI, TALUKA-MANGROL

DISTT: SURAT, GUJARAT

**PART –I**

**(TECHNICAL BID SPECIFICATION, NOTICE INVITING TENDER and GCC)**



**BHARAT HEAVY ELECTRICALS LIMITED**  
(A GOVERNMENT OF INDIA UNDERTAKING)  
POWER SECTOR : WESTERN REGION  
345, KINGSWAY : NAGPUR 440 001

**BHARAT HEAVY ELECTRICALS LIMITED**

(A Govt. of India Undertaking)  
POWER SECTOR - WESTERN REGION  
345, KINGS WAY - NAGPUR 440 001

**No: BHE/PW/PUR/SLT-CBL/538**

FOR

**HANDLING AT SITE STORES/STORAGE YARD, TRANSPORTATION TO SITE OF WORK,  
COMPLETE ERECTION, TESTING, COMMISSIONING AND HANDING OVER OF  
ELECTRICAL CABLING PACKAGES EARHTING AND LIGHTNING PROTECTION SYSTEM  
AND ASSOCIATED ITEMS FOR UNIT #1&2 of 125 MW**

AT

**GUJARAT INDUSTRIAL POWER COMPANY LIMITED**

EXPANSION OF SURAT LIGNITE POWER PLANT (SLPP)

NANI NAROLI, TALUKA-MANGROL

DISTT: SURAT, GUJARAT

EARNEST MONEY DEPOSIT: RS. (RUPEES LAKHS THOUSAND ONLY)

LAST DATE AND TIME FOR

SUBMISSION OF OFFERS: PLEASE REFER WEB PAGE ([www.bhel.com](http://www.bhel.com)) FOR LATEST  
UPDATES.

THESE TENDER DOCUMENTS CONTAINING PART-I TECHNICAL BID AND PART-II PRICE BID,  
ARE ISSUED TO:

M/s.....

.....

(THESE TENDER DOCUMENTS ARE NOT TRANSFERABLE)

FOR BHARAT HEAVY ELECTRICALS LIMITED

Dy. GENERAL MANAGER (PURCHASE)

PLACE: NAGPUR

DATE :

## PROJECT INFORMATION

### INTRODUCTION

**GUJARAT INDUSTRIES POWER COMPANY LIMITED (GIPCL)**, AS PART OF EXPANSION PLAN IS INSTALLING THE TWO UNITS EACH OF 125 MW UNDER "2X125 MW, EXPANSION PROJECT (PHASE II)-UNIT-3 & 4" PLAN IN THEIR EXISTING 2X125 MW PHASE-I PREMISE AT SURAT LIGNITE POWER PLANT (SLPP), NANI NAROLI, P.O. NANI NAROLI-394110, TALUKA- MANGROL, DIST.- SURAT.

THE SITE IS LOCATED AT A DISTANCE OF APPROXIMATELY 28 KMS FROM KOSAMBA, VILLAGE NANI NAROLI, TALUK MANGROL, DISTRICT SURAT, GUJARAT STATE,

#### *THE FURTHER INFORMATIONS ARE AS GIVEN BELOW:*

- |      |                                    |   |   |
|------|------------------------------------|---|---|
| 1.0  | CUSTOMER                           | : | Gujarat Industries Power Co. Ltd.<br>P. O. Petrochemicals – 391 346<br>District Baroda, India   |
| 2.0  | CONSULTANT                         | : | TCE Consulting Engineers Limited<br>73/1, St. Mark's Road<br>Bangalore – 560 001.   |
| 3.0  | PROJECT                            | : | Surat Lignite Power Plant<br>2 x 125MW – Phase II (Expansion Project) Unit<br>Nos. 3 & 4  |
| 4.0  | LOCATION                           | : | At a distance of 28 kms from Kosamba, Village<br>Nani Naroli, Taluk Mangrol, District Surat, Gujarat<br>State, India.   |
| 5.0  | NEAREST AIRPORT                    | : | Baroda, Gujarat State   |
| 6.0  | ROAD APPROACH                      | : | Accessible by road from two points Kim and<br>Kosamba which are on Mumbai-Ahmedabad<br>highway. From Kim, the site is around 23 kms and<br>from Kosamba, the site is around 28 kms. |
| 7.0  | NEAREST RAILWAY STATION            | : | Kim/Kosamba is on Mumbai-Ahmedabad broad<br>gauge line. Same is at a distance of 32 kms from<br>the proposed power project site.  |
| 8.0  | NEAREST PORT                       | : | Mumbai  |
| 9.0  | ALTITUDE                           | : | About 50 m above mean sea level.  |
| 10.0 | SEISMIC ZONE                       | : | Zone – III as per Indian Standard IS:1893 (Current<br>Issue).   |
| 11.0 | RAINFALL(ANNUAL TOTAL<br>R.O.MEAN) | : | 1800 mm (Maximum rainfall occurs during June<br>to September)   |
| 12.0 | AMBIENT AIR EMPERATURE             | : |   |
|      | (a) Maximum dry bulb               | : | 45.6 Deg. C.  |
|      | (b) Minimum dry bulb               | : | 4.4 Deg. C.   |

- (c) Maximum daily average dry bulb : 37.3 Deg. C
  - (d) Reference Temperature for design of electrical equipment / devices : (+) 50 Deg. C
- 13.0 RELATIVE HUMIDITY
- (a) Maximum : 87%
  - (b) Minimum : 33%
  - (c) Average : 71%
  - (d) Relative humidity for design of equipment / devices : (+) 100%
- 14.0 CLIMATIC CONDITION : Hot, humid and dusty.
- 15.0 WIND DATA
- 15.1 (a) Wind load as per IS 875 (Part-3) 1987
- (i) Basic wind speed : 44 m/sec.
  - (ii) Factor K1 : 1.07
  - (iii) Terrain category 1 & the corresponding value of K2 : 1.09

**ABOVE INFORMATION FURNISHED ARE FOR GENERAL GUIDANCE OF CONTRACTOR. CONTRACTOR IS ADVISED TO VISIT THE SITE AND APPRAISE HIMSELF ABOUT THE CONDITIONS OF SITE AND INFRASTRUCTURE AVAILABLE IN THE AREA FOR FULFILLING THEIR COMMITMENTS UNDER THE CONTRACT.**

<b>Check List</b>			
(Vide Para 1.3 Of Section-I of General Conditions Of Contract)			
1	Name of the Bidder with Postal Address for Correspondence		
2	Name of Contact Person with Telephone & Fax No.	Mr./Ms Tel No. Fax No.	
3	Nature of the firm	PROPRIETARY / PARTNERSHIP / LIMITED CO.	
4	Details of EMD  Please Indicate whether  One Time EMD or,  Only for this Tender	DD No. .... DD Date..... Name of Bank..... Amount: Rs.....	
5	Validity of Offer (BHEL's Requirement: 180 days from Due Date)	Validity _____ days	
6	Mobilization Time (Please refer Section- 11 of SCC)	Mobilization Time _____	
7	Whether any conditions stipulated?	<b>Yes</b> (vide Document reference:	<b>No</b>
		<b>Bidder to note that tender with conditions unacceptable to BHEL shall be rejected.</b>	
8	Bidder has visited the project site and acquainted with the site conditions	Yes	No
9	Details of concurrent jobs are furnished ( <b>Appendix- )</b>	Yes	No
10	Headquarters organization is furnished	Yes	No
11	Proposed site organization is furnished	Yes	No
12	Names and particulars of directors/partners are furnished	Yes	No

**Check List**

(Vide Para 1.3 Of Section-I of General Conditions Of Contract)

13	Financial status of the firm ( <b>Annexure 'A' of GCC</b> ) is furnished	Yes	No
14	<b>Profit &amp; Loss Account</b> for preceding three years is furnished	Yes	No
15	<b>Latest Certificate by Bidder's Banker for Overdraft &amp; BG Limits</b> is Furnished (Certificate shall not be older than six months from the Last Date for offer submission)	Yes	No
16	Latest copy of <b>IT Return</b> along with copy of <b>PAN Card</b> are Furnished	Yes	No
17	Month-wise <b>Manpower Deployment Plan (Appendix – )</b> is furnished	Yes	No
18	<b>Analysis of Unit Rates</b> quoted ( <b>Appendix-</b> ) is furnished	Yes	No
19	<b>Month-wise deployment plan for major T&amp;P (Appendix-)</b> is furnished	Yes	No
20	Whether all the pages of the Tender Specification documents are read, understood and signed	Yes	No
21	<b>Power of Attorney</b> enclosed in favour of person making offer	Yes	No
22	Bidder has familiarized himself with all Relevant Local Laws & Local Conditions	Yes	No
23	Safety Requirement of this work in a Running plant Premises has been understood.	Yes	No
24	Erection and Commissioning programme furnished	Yes	No
25	<b>List of Jobs completed</b> in last seven years is furnished ( <b>Appendix-</b> )	Yes	No
26	Whether <b>copies of detailed Work Orders (with BOQ)</b> and <b>Completion Certificates</b> in support of above furnished	Yes	No
27	Whether contractor has left any job unfinished? If so, give reasons.	Yes	No
28	Whether any client has terminated the contractor's work before completion? If so, furnish reasons for the same	Yes	No

Note: strike off or tick 'yes' or 'no', as applicable

Date:

Signature of Bidder

## DECLARATION BY BIDDER'S AUTHORIZED REPRESENTATIVE

I, \_\_\_\_\_, HEREBY CERTIFY THAT ALL THE INFORMATION AND DATA FURNISHED BY ME WITH REGARD TO THE TENDER SPECIFICATION NO. **BHE/PW/PUR/SLT-CBL/538** ARE TRUE AND COMPLETE TO THE BEST OF MY KNOWLEDGE. I HAVE GONE THROUGH THE SPECIFICATIONS, CONDITIONS AND STIPULATIONS IN DETAIL AND AGREE TO COMPLY WITH THE REQUIREMENTS AND INTENT OF THE SPECIFICATION. I FURTHER CERTIFY THAT I AM DULY AUTHORIZED REPRESENTATIVE OF THE UNDER-MENTIONED TENDERER AND A VALID POWER OF ATTORNEY TO THIS EFFECT IS ALSO ENCLOSED.

AUTHORISED REPRESENTATIVE'S SIGNATURE WITH  
NAME AND ADDRESS

DATE:

TENDERER'S NAME AND ADDRESS

*CERTIFICATE OF NO DEVIATION*

**TENDER SPECIFICATION NO.**

**BHE/PW/PUR/SLT-CBL/538**

**I/WE, M/s** .....

HEREBY CERTIFY THAT NOTWITHSTANDING ANY CONTRARY INDICATIONS/ CONDITIONS ELSEWHERE IN OUR OFFER DOCUMENTS, I/WE HAVE NEITHER SET ANY TERMS AND CONDITIONS NOR THERE IS ANY DEVIATION TAKEN FROM THE CONDITIONS OF BHEL'S TENDER SPECIFICATIONS, EITHER TECHNICAL OR COMMERCIAL, AND I/WE AGREE TO ALL THE TERMS AND CONDITIONS MENTIONED IN BHEL'S TENDER SPECIFICATION WITH ASSOCIATED AMENDMENTS AND CLARIFICATIONS.

DATE:

SIGNATURE OF BIDDER

**SECTION-3  
OFFER OF THE BIDDER**

To,  
DGM (PURCHASE)  
BHARAT HEAVY ELECTRICALS LIMITED  
POWER SECTOR - WESTERN REGION  
SHREEMOHINI COMPLEX  
345, KINGS WAY  
NAGPUR 440 001

DEAR SIR,

I/WE HEREBY OFFER TO CARRY OUT THE WORK DETAILED IN TENDER SPECIFICATION NO. **BHE/PW/PUR/SLT-CBL/538** FOR UNIT-1 & 2 OF 2X250 MW, NTPC-SAIL Power Company Pvt. Ltd. AT BHILAI, DIST DURG (C.G.) ISSUED BY BHARAT HEAVY ELECTRICALS LIMITED, POWER SECTOR-WESTERN REGION, NAGPUR, IN ACCORDANCE WITH THE TERMS AND CONDITIONS THEREOF.

I/WE HAVE CAREFULLY PERUSED THE FOLLOWING DOCUMENTS CONNECTED WITH THE ABOVE WORK AND AGREE TO ABIDE BY THE SAME.

1. INSTRUCTIONS TO TENDERERS
2. GENERAL CONDITIONS OF CONTRACT
3. SPECIAL CONDITIONS OF CONTRACT
4. OTHER SECTIONS, APPENDICES, SCHEDULES AND DRAWINGS.

I/WE HAVE DEPOSITED / FORWARDED HERewith THE EARNEST MONEY DEPOSIT AS SPECIFIED IN THE TENDER SPECIFICATION. DETAILS OF EMD PAYMENT ARE FURNISHED IN THE CHECK LIST.

EMD SHALL BE REFUNDED SHOULD OUR OFFER NOT BE ACCEPTED / EMD **NEED NOT BE REFUNDED AND THE AMOUNT MAY BE TREATED AS "ONE TIME EMD" FOR ERECTION AND COMMISSIONING TENDERS OF BHEL-PSWR, NAGPUR.** SHOULD OUR OFFER BE ACCEPTED, I/WE FURTHER AGREE TO DEPOSIT SECURITY DEPOSIT FOR THE WORK AS PROVIDED FOR IN THE TENDER SPECIFICATION WITHIN THE STIPULATED TIME AS MAY SBE INDICATED BY BHEL, POWER SECTOR-WESTERN REGION, NAGPUR.

OR,

WE HAVE ALREADY DEPOSITED ONE TIME EMD OF Rs. 2,00,000/- (RUPEES TWO LACS ONLY), DETAILS OF WHICH ARE FURNISHED IN THE CHECK LIST.

I/WE FURTHER AGREE TO EXECUTE ALL THE WORKS REFERRED TO IN THE SAID DOCUMENTS UPON THE TERMS AND CONDITIONS CONTAINED OR REFERRED TO THEREIN AND AS DETAILED IN THE APPENDICES ANNEXED THERETO.

PLACE:  
DATE:

SIGNATURE OF TENDERER:  
ADDRESS:

WITNESSES WITH THEIR ADDRESS

SIGNATURE	NAME	ADDRESS
-----------	------	---------

1.

2.

## **Procedure for Submission of Sealed Tenders & Instructions to Bidders**

The bidder must submit their tenders as required in two parts in separate sealed covers prominently super scribed as part-I technical bid and part-II price bid and also indicating on each of the covers the tender specification number and due date and time as mentioned in the tender notice.

### **Part-I (Technical Bid) cover-I:**

Excepting rate schedule, all other schedules, data sheets and details called for in the specification shall be enclosed in part-I "Technical Bid" only.

### **EARNEST MONEY DEPOSIT (EMD)**

EMD shall be included in the Technical Bid. **EMD shall be paid by bidders only in the form of account payee Demand Draft payable at Nagpur in favour of Bharat Heavy Electricals Limited.** No other mode of payment of EMD shall be acceptable. Provisions under clause no. 1.4 of the General Conditions of the Contract shall stand withdrawn for this tender.

Bidder may opt to deposit "One Time EMD" of Rs. 2.0 lacs with this office (BHEL:PSWR:Nagpur) which will enable them to participate in all the future tender enquiries in respect of Erection and Commissioning services issued from this office. Interested bidders may clearly sent their consent for converting the present EMD into an "One Time EMD" in their offer.

Bidders who have already submitted such "One Time EMD" will be exempted from submission of any EMD for this tender. However bidder shall furnish details of the "One Time EMD" in his offer including the Check List furnished herein.

### **Part-II (Price Bid) cover-II:**

All indications of price shall be given in this part-II "Price Bid". **EMD shall not be included in this cover.**

These two separate covers-I and II (part-I and part-II) shall together be enclosed in a third envelope (cover-III) along with requisite EMD as indicated earlier and this sealed cover shall be super scribed and submitted to Dy. Gen Manager (Purchase) at the above-mentioned address on or before the due date as indicated.

The qualified bidder will be intimated separately about the status of their offer.

Bidder are requested to make specific note of the following conditions:

1. Contractor should have adequate resources including major T&P at his disposal for this job.

2. Contractor should have sound financial stability.
3. Bidder should meet quality requirement regarding workmanship, deployment of personnel, erection tools and necessary inspection, measurement & testing instruments.
4. All information as called for in various appendices and clauses of tender specification, should be furnished in completeness. Please refer the checklist.
5. Clarification on tender if any, shall be asked by bidders at least seven days before Due date as stipulated in the NIT.
6. Offers must be submitted without any deviation.
7. Offers received with any deviation or without relevant information as described above are liable to be rejected. Price bids received in the form other than specified in Part-II (Price Bid) are liable to be rejected.
8. **Bidder shall note that their offer will be considered subject to the approval of BHEL's customer.**

## CHECK LIST

(VIDE PARA 1.3 OF SECTION-I - GENERAL CONDITIONS OF CONTRACT)

1	Name of the Bidder with Postal Address for Correspondence	
2	Name of Contact Person with Telephone & Fax No.	Mr./Ms Tel No. Fax No.
3	Nature of the firm	PROPRIETARY / PARTNERSHIP / LIMITED CO.
4	Details of EMD  Please Indicate whether 1) One Time EMD or, 2) Only for this Tender	DD No. .... DD Dtd..... Name of Bank..... Amount: Rs.....
5	Validity of Offer (BHEL's Requirement: 180 days from Due Date)	
6	Mobilisation Time ((BHEL's Requirement: Not Exceeding four weeks from Fax L.O.I.).	
7	Whether Bidder has visited the project site and acquainted themselves with the local conditions and situations.	YES/NO
8	Whether "No Deviation Certificate" Furnished	YES/NO
9	Details of similar jobs executed during the last seven years as in "Appendix-VIII" enclosed	YES/NO
10	Whether copies of detailed Work Orders (with BOQ) and Completion Certificates in support of above furnished	YES/NO
11	Details of Concurrent Jobs Furnished in "Appendix-VII" furnished	YES/NO
12	Headquarter Organisation Chart furnished	YES/NO
13	Names & Particulars of Directors/Partners/Proprietor furnished	YES/NO

14	Proposed Site Organisation Chart indicating executives and supervisors furnished	YES/NO
15	Financial Viability furnished as in Annexure-I of GCC	YES/NO
16	Profit & Loss account for the preceding 3 years furnished	YES/NO
17	Latest Solvency Certificate copy enclosed	YES/NO
18	Income Tax Clearance Certificate copy enclosed	YES/NO
19	Monthly Manpower Deployment plan as in Appendix-IV enclosed	YES/NO
20	Deployment plan for major T&P and MMD enclosed as in Appendix-VI	YES/NO
21	Month-wise Erection & Commissioning plan enclosed	YES/NO
22	Analysis of Unit Rate Quoted as in Appendix-V furnished	YES/NO
23	List of other tools and plants/tackles/ instruments contractor proposes to deploy for the work and special tools and instruments in his possession.	ENCLOSED / NOT ENCLOSED
24	Whether contractor has left any job unfinished? if so, give reasons.	YES/NO
25	Whether any client has terminated the contractor's work before completion? If so, furnish reasons for the same	YES/NO
26	Whether the tenderer has understood all Quality Control & Quality Assurance requirements?	YES/NO
27	Whether the tenderer is aware of all safety rules/codes? Whether the list of safety equipments proposed to be employed for this work is enclosed.	YES/NO
28	Whether Power of Attorney in favour of the person making this offer enclosed?	YES/NO
29	Whether all the pages are read, understood and signed and the signed copy of tender book submitted?	YES/NO

PLACE:

DATE :

SIGNATURE OF TENDERER WITH SEAL

## Declaration by Bidder's Authorized Signatory

I, \_\_\_\_\_ hereby certify that all the information and data furnished by me with regard to the Tender Specification No. BHE/PW/PUR/SLT-CBL/538 are true and complete to the best of my knowledge. I have gone through the specifications, conditions and stipulations in detail and agree to comply with the requirements and intent of the specification. **I further certify that I am duly authorized representative of the under-mentioned bidder and a valid power of attorney to this effect is also enclosed with the tender.**

Authorized representative's signature with  
Name and address

Date:

Bidder's Name and Address

***Certificate of No Deviation***

**Tender Specification No. BHE/PW/PUR/SLT-CBL/538**

I/WE, M/s .....

HEREBY CERTIFY THAT IN OUR OFFER I/WE HAVE NEITHER SET ANY TERMS AND CONDITIONS NOR THERE ANY DEVIATION TAKEN FROM THE CONDITIONS OF CONTRACT, EITHER TECHNICAL OR COMMERCIAL, AND I/WE AGREE TO ALL THE TERMS AND CONDITIONS MENTIONED IN THE TENDER SPECIFICATION UNDER REFERENCE ABOVE INCLUNG NOTICE INVITING TENDER, ALL ASSOCIATED CLARIFICATIONS AND AMENDMENTS.

Date:

Signature of the Bidder  
and Official Seal

## SECTION-4

### SPECIAL CONDITIONS OF CONTRACT

#### 4.0 SCOPE OF WORK

The work under these specifications broadly covers the complete work of handling at storage yard/stores, transportation to work site, pre-assembly, erection, testing, pre-commissioning tests and checks and handing over of Electrical Cabling package, earthing and lightning Protection system Equipment & Associated items .

For proper planning, monitoring and smooth execution of job at site, the contractor will be required to maintain his own computer, printer etc along with operator at his site office.

BHEL uses its own software SOMS (Site Operation and Management System) for total project execution and billing. The contractor shall also provide adequate and suitable manpower for updating/entries into SOMS in BHEL computers at site.

**Scope of work is further detailed in various clauses hereafter.**

#### 4.1 GENERAL REQUIREMENTS

- 4.1.1 The intent of specification is to provide services according to the most modern and proven techniques and codes. The omission of specific reference to any method, equipment or material necessary for proper and efficient execution of this work shall not relieve the contractor of the responsibility of providing such facilities to complete the work without any extra compensation.
- 4.1.2 The work to be carried out under the scope of this specification covers the complete work of loading, handling, transporting, unloading, preassembly, erection, calibration, testing, air flushing, pre-commissioning tests, commissioning of systems, trial run of various auxiliaries and equipments, achieving various milestones till handing over of the unit to BHEL's customer. The work shall conform to dimensions and tolerances specified in various drawings that will be provided during the erection. If any portion of the work is found to be defective in workmanship or not conforming to drawings or other specifications, the contractor shall dismantle and re-do the work duly replacing the defective materials at his cost, failing which the work will be got done by engaging other agencies or departmentally and recoveries will be effected from contractor's bills towards expenditure incurred including 30% departmental charges.
- 4.1.3 The terminal points decided by BHEL should be final and binding on the contractor for deciding the scope of work and effecting payment for the work done.
- 4.1.4 The work shall be executed under the usual conditions affecting major power plant construction and in conjunction with numerous other operations at site. The contractor and his personnel shall cooperate with personnel of

BHEL, BHEL's customer, customer's consultants and other contractors, coordinating his work with others and proceed in a manner that shall not delay or hinder the progress of work of the project as a whole.

- 4.1.5 The work covered under this specification is of highly sophisticated nature, requiring the best quality workmanship, supervision, engineering and construction management. The contractor should ensure proper planning and successful & timely completion of the work to meet the overall project schedule. The contractor must deploy adequate quantity of tools & plants, modern/latest construction aids etc. He must also deploy adequate trained, qualified and experienced supervisory staff and skilled personnel.
- 4.1.6 Contractor shall erect, align and commission all the equipments and auxiliaries as per the sequence & methodology prescribed by BHEL depending upon the technical requirements. Availability of materials and fronts will decide this. BHEL engineer's decision regarding correctness of the work and method of working shall be final and binding on the contractor. No claims for extra payment from the contractor will be entertained on the ground of deviation from the methods / sequences adopted in erection of similar sets elsewhere.
- 4.1.7 All necessary certificates and licenses, permits & clearances required to carry out this work from the respective statutory authorities are to be arranged by the contractor expeditiously at his cost and in time to ensure smooth progress of work.
- 4.1.8 The work shall conform to dimensions and tolerances specified in the various drawings / documents that will be provided during various stages of erection. If any portion of work is found to be defective in workmanship, not conforming to drawings or other stipulations due to contractor's fault, the contractor shall dismantle and re-do the work duly replacing the defective materials at his cost, failing which the work will be got done by BHEL and recoveries will be effected from the contractor's bills towards expenditure incurred including cost of materials and 30% departmental overheads of BHEL.
- 4.1.9 Contractor will be required to maintain in his site office at least one PC along with minimum accessories like printer, etc to enable him to carry out site activities in a planned, well coordinated and smooth manner.
- 4.1.10 The contractor shall execute the work in the most substantial and workmanlike manner. The stores shall be handled with care and diligence.
- 4.1.11 BHEL reserves right to recover from the contractor any loss, which arises out of undue delay/discrepancy/shortage/damage, or any other causes due to contractor's lapse during any stage of work. Any loss to BHEL due to contractor's lapse shall have to be made good by the contractor.
- 4.1.12 All transport equipment, handling equipment, tools, tackles, fixtures, equipment, materials, manpower, supervisors/engineers, consumables etc., except otherwise specified as BHEL scope of free issue, required for this

scope of work shall be provided by the contractor. All expenditure including taxes and incidentals in this connection will have to be borne by him unless otherwise specified in the relevant clauses. The contractor's quoted rates should be inclusive of all such contingencies.

- 4.1.13 During the course of erection, testing and commissioning certain rework/ modification / rectification / repair / fabrication etc. may become necessary on account of feedback / revision of drawing. This will also include modifications / re-works suggested by BHEL / customer / other inspection group. Contractor shall carry out such rework / modification / rectification / fabrication / repair etc., promptly and expeditiously. Daily log sheets signed by BHEL engineer and indicating the details of work carried out, man-hours etc. shall be maintained by the contractor for such reworks. Claim of contractor if any, for such works will be governed by clauses 13.1 to 13.8.
- 4.1.14 All works such as cleaning, levelling, aligning, trial assembly, dismantling of certain equipments / components for checking and cleaning, surface preparation, fabrication of sheets, tubes and pipes as per general engineering practice and as per BHEL engineer's instructions at site, cutting, gouging, weld depositing, grinding, straightening, chamfering, filing, chipping, drilling, reaming, scrapping, lapping, fitting up etc., as may be applicable in such erection works and which are treated incidental to the erection works and necessary to complete the work satisfactorily, shall be carried out by the contractor as part of the work within the quoted rates.
- 4.1.15 The contractor shall make all fixtures, temporary supports, steel structures required for jigs & fixtures, anchors for load and guide pulleys required for the work (excepting those specifically included in BHEL scope). However, necessary steel will be provided from the scrap / surplus materials available at site.
- 4.1.16 The contractor shall take delivery of the components, equipments etc from the BHEL stores/ storage area after getting the approval of BHEL engineer on standard indent forms of BHEL. Complete and detailed account of the materials and equipments after usage shall be submitted to the BHEL and reconciled periodically. While taking delivery of items from store it may be necessary to handle (shift / relocate) other items (not necessarily those in the scope of the contractor). Separate payment will NOT be made if such situations arise.
- 4.1.17 Contractor shall plan and transport equipments, components from storage to erection site and erect them in such a manner and sequence that material accumulation at site does not lead to congestion at site of work. Materials shall be stacked neatly, preserved and stored in the contractor's shed and at work areas in an orderly manner. In case it is necessary to shift and re-stack the materials kept at work areas/ site to enable other agencies to carry out their work or for any other reason, contractor shall do it most expeditiously. No claim for extra payment for such work will be entertained.
- 4.1.18 Plant materials should not be used for any temporary supports / scaffolding / preparing pre-assembly bed etc.

- 4.1.19 The services, tests and support to be provided by the agency for the work mentioned in various sections of this tender are indicative and not exhaustive, but not limited to these for completion of the work in all respects.**
- 4.1.20 All the work shall be carried out as per the instructions of BHEL engineer. BHEL engineer's decision regarding the correctness of the work and method of working shall be final and binding on the contractor.
- 4.1.21 The weights & dimensions as mentioned against the individual items in Price Bid Part –II “Rate Schedule” are indicative approximate and there may be variation in dimension & weight in actual supply of equipment. No rate variation shall be considered on this account.**
- 4.1.22 The scope of work & description of system / equipment as given in the various clause of this tender specification and rate schedule are only for understanding the system requirement, contractor shall note this point and assess the volume of work prior to submit the offer. No compensation shall be considered later on.
- 4.1.23 The contractor shall have total responsibility for all equipment and materials in his custody at contractor's stores, loose, semi-assembled, assembled or erected by him at site. He shall effectively protect the finished works from action of weather and from damages or defacement and shall also cover the finished parts immediately on completion of work as per BHEL engineer's instructions. The machine surfaces/finished surfaces should be greased and covered.
- 4.1.24 At all stages of work, equipments/materials in the custody of contractor, including those erected, will have to be preserved as per the instructions of BHEL.
- 4.1.25 The contractor shall make suitable security arrangements including employment of security personnel and ensure protection of all materials/equipment in their custody and installed equipments from theft/fire/pilferage and any other damages and losses.
- 4.1.26 Contractor shall collect all scrap materials periodically from various area of work site, deposit the same at one place earmarked at site or shift the same to a place earmarked in BHEL/ client's stores. In case of failure of contractor in compliance of this requirement, BHEL will make suitable arrangement at contractor's risk and cost.
- 4.1.27 The entire surplus, damaged, unused materials, packaging materials / containers, special transporting frames, gunny bags, etc., shall be returned to BHEL stores by the contractor.
- 4.1.28 The contractor shall not waste any materials issued to him. In case it is observed at any stage that the wastage/excess utilisation of materials is not within the permissible limits, recovery for the excess quantity used or

wasted will be effected with departmental charges from the contractor. Decision of BHEL on this will be final and binding on the contractor.

- 4.1.29 For any class of work for which no specifications have been laid down in these specifications, work shall be executed as per the instructions of BHEL engineer.
- 4.1.30 House keeping in the erection and preassembly area is as important as the well-planned and orderly work. The access to site for inspection, approaches by BHEL and customer engineers and leading of the material shall be made available by the contractor at all times. The shifting and resifting of erection materials, tools and plants and clearance of restrictions, filling of ditches, undulation near the pre-assembly and boiler area is the responsibility of the contractor. Contractor should visit the site and acquaint himself with all restrictions and difficulties that he may encounter during erection/commissioning stages.
- 4.1.31 The contractor shall take delivery of equipment, materials from the storage yard/ stores/sheds of BHEL/customer he shall also make arrangements for verification of equipment, transportation up to site of work, safe custody, watch and ward of equipment after it has been handed over to him till these are fully erected, tested and commissioned and taken over by the customer. The contractor should note that the transport of equipments to erection site, assembly yards etc. should be done by the prescribed route without disturbing the other works and contractors and in the most professional manner. Special equipments such as measuring and control equipments, panels, console inserts, switches, cables, conduits etc. shall be stored when taken over by the contractor in appropriate manner as per BHEL's instructions.
- 4.1.32 The contractor shall handover all parts/materials remaining extra over the normal requirement with proper identification tags in a packed condition to BHEL stores. In case of any misuse or use over actual design requirements, BHEL reserves the right to recover the cost of parts/materials used in excess or misused. Decision of BHEL engineer in this regard will be final and binding on the contractor.
- 4.1.33 The contractor should take all reasonable care to protect equipment and materials under his custody either in his stores or at site. Certain Items forming an integral part of equipment or system are liable to greater damages / pilferages /theft / losses. It will be responsibility of contractor to arrange for adequate security round the clock for protection from such damages/pilferages/theft/losses.
- 4.1.34 The contractor shall ensure that all the packing materials and protection devices used for the various equipments during transit and storage are removed before these equipments are erected in position.
- 4.1.35 Overhauling, cleaning, revisioning, servicing of items during erection and commissioning stages will be arranged by the contractor. All

equipments shall be preserved and protected before and after erection as per the advice of BHEL engineer.

- 4.1.36 Equipment erection like panels, Motors Transformers etc shall be done by other agencies for that equipment for which cabling, earthing & lightning protection work covered under this tender specification. The glands & lugs shall be supplied either loose or fitted with the equipments. Contractor shall take care of this aspect at the time of receipt of the Lugs glands etc from BHEL stores or other agencies and maintain proper records of Receipt and consumption of these items. Contractor shall account for the quantities received with equipments and shall hand over receipt for the same to other agency under intimation to BHEL Engineer. Contractor shall extend all necessary help & co-ordinate with the equipment erection agency during the course of work.
- 4.1.37 Contractor shall prepare Marked-Up drawings incorporating modifications and deviations from original drawings or prepare fresh sketch for actual installation / connection details if need be, that can be converted to "As-built" drawing.

## **4.2 WELDING, NON-DESTRUCTIVE TESTING ETC.**

- A) Installation of equipment involves good quality welding, NDE checks etc.
- B) Welding of all structural steel & aluminium shall be done only by the qualified and approved welders.
- C) All the welders shall be tested and approved by BHEL engineer before they are actually engaged on work though they may possess the IBR/other certificate. BHEL reserves the right to reject any welder without assigning any reason.
- D) The welded surface shall be cleaned of slag and painted with primer paint to prevent corrosion. For this paint will be supplied by the contractor.
- F) Welding electrodes have to be stored in enclosures having temperature and humidity control arrangement. This enclosure shall meet BHEL specifications.
- G) Certain types of coated welding electrodes, prior to their use, call for baking for specified period and will have to be held at specified temperature for specified period. Also, during execution, the coated welding electrodes have to be carried in portable ovens.

## **4.3 TESTING, PRE-COMMISSIONING, AND POST COMMISSIONING:**

- 4.3.1 The contractor shall perform various activities during pre-commissioning, Integrated Testing, post-commissioning stages of equipment covered under this tender specification. It is responsibility of contractor to arranged tools & plants, test equipments, experienced engineers and technicians. Contractor shall earmark separate manpower for respective area of as specified in relevant clause and shall not be disturbed /diverted for other work. The contractor's commissioning group shall work as per the instruction of BHEL Engineer and they shall coordinate day-to-day activity with other agency and BHEL/ Customer. The testing activity may have to be repeated till satisfactory results

are obtained and also to satisfy the requirement of Customer / statutory Authority.

- 4.3.2 The contractor shall simultaneously start testing & commissioning activities for equipments to match the mile stone activities of the project.
- 4.3.3 The mobilization of these commissioning groups shall be such that planned activities are taken up in time and also completed as per schedule and work undertaken round the clock if required. It is responsibility of contractor to discuss on day to day / weekly / monthly basis the requirement of manpower, consumables, tools & tackles / testing equipments with BHEL Engineers and arrange for the same. If at any time the requisite manpower, consumables etc are not arranged then BHEL shall make alternative arrangements and necessary recoveries with overhead cost will be made from the running bills.
- 4.3.4 Contractor shall cut/open work, if needed, as per BHEL engineer's instructions during commissioning for inspection, checking and make good the works after inspection is over.
- 4.3.5 It shall be specifically noted that the contractor may have to work round the clock and in shifts during the pre-commissioning and commissioning period along with or without BHEL engineers and hence considerable overtime payment is involved. The contractor's quoted rates shall be inclusive of all these factors.
- 4.3.6 In case any rework/ repair / rectification/ modification / fabrication etc is required because of contractor's faulty workmanship which are noticed during the commissioning of, at any stages, the same shall be rectified by the contractor at his cost. If during the commissioning any improvement / repair / rework / rectification / fabrication / modification due to design improvement is required, the same shall be carried out by the contractor promptly and expeditiously. Claim if any, for such work from the contractor shall be governed by clause no. 13.1 to 13.8.
- 4.3.7 During the commissioning activities and carrying out various tests, if any of temporarily work such mounting of test equipments / cabling etc are required, the contractor shall carry out such work without on any extra cost. The same shall be removed after completion of the activity.
- 4.3.8 During this period, though BHEL/ client's staff will also be associated in the work, the contractor's responsibility will be to arrange for complete requirement of men and required Tools & Plants, Consumables, Scaffolding and approaches etc., till such time the commissioned unit is taken over for trial operations.
- 4.3.9 The contractor shall carry out any other tests as desired by BHEL engineer on erected equipment covered under the scope of this contract during testing, pre-commissioning and commissioning, to demonstrate the completion of any part or whole of work performed by the contractor.
- 4.3.10 The pre-commissioning activities will start in phased manner to meet the various milestones and shall continue till equipments are being commissioning

fully with all connected drives/ equipment to HT/LT switchgear or handed over to customer for regular operation. In this duration cabling or other work shall be carried out even though HT/LT switchgear board are charged. In order to co-ordinate the work such as issue of safety permit, normalization and compliance of other requirement, contractor shall keep team of one experience engineer / supervisor, in each shift OR as decided by BHEL Engineer. The team shall take instruction from BHEL Engineer for day-to-day work and shall not be diverted for other work without BHEL Engineer's permission. No extra payment shall be made for their services.

#### **4.4.1 MEASUREMENTS & WASTAGE & CUTTING ALLOWANCES:**

4.4.1 For all payment purposes, measurement shall be made on the basis of actual execution in line with drawings/documents/site requirements.

4.4.2 The measurement for cable, impulse pipes/tubes, GI pipe, conduits, flexible conduits, trays etc. shall be made on the basis of length actually laid.

4.4.3 All the surplus, scrap and serviceable materials, out of the quantity issued to the contractor shall be returned to BHEL in good condition and as directed by the engineer.

4.4.4 All materials returned to stores should carry an Aluminium tag indicating the size and type. More than 5 metres length shall be termed as serviceable and shall be returned size wise and category wise to the owner's stores/yard. Cable of serviceable length being returned to the stores in drums shall have their free ends sealed and the balance lengths on the drum(s) shall be noted and certified by the Engineer-in-charge. This shall be applicable only for the purpose of accounting the cables issued for installation.

4.4.5 While carrying out material appropriation with contractor, all the above points will be taken into account. All serviceable material returned by the contractor shall be deducted from the quantities issued for the respective sizes and categories and the balance quantity(ies) will be taken as the net quantity(ies) issued to the contractor. Material appropriation shall be done and allowable scrap quantity calculated as per wastage allowance percentage specified above. Any scrap/wastage generated by the contractor in excess of the allowable percentage shall be charged at the rates decided by the Engineer whose decision shall be final and binding on the contractor.

4.4.6 For all site-fabricated steel items such as supports, racks , frame , Canopy etc. physical measurement shall be made and then converted to tonnage . For steel material supplied to the contractor, all scrap shall be returned to BHEL stores with due accounting.

4.4.7 Every month the contractor shall submit an account for all the materials issued to him by BHEL in the standard Performa prescribed for this purpose by the site in charge.

4.4.8 The erection contractor shall make every effort to minimize wastage during erection work. Cutting and wastage allowance shall be computed on length/

weight of material actually used, measured and accepted. In any case, the wastage shall not exceed the following upper limits.

Sl No.	Item	% Wastage on issued Qty
01.	Each iron/steel section	2
02.	Each size of power cables	As per data sheet –A in section -16
03.	Each size of control cables	As per data sheet –A in section -16

4.4.9 If the actual wastage is more than the specified limits, cost of the excess portion will be recovered from the contractor's bill.

4.4.10 The cable take off from drums shall be planned strategically such that jointing in the run of cables and wastage are avoided. For this purpose the exact route length between various equipment/panels as per the cable schedule shall be measured and the route length recorded before laying of the cables. Depending upon the route length the type of cable required for various destinations, the cable drums should be suitably selected for cable laying. Any jointing shall be approved by the BHEL engineer. All the cut pieces/bits of cables, which are not used/unused, shall be returned to the purchaser for accounting towards wastage. The cables damaged by the contractor shall have to be replaced by the contractor at his own cost.

**NOTES:**

Salvageable scrap shall mean lengths of pipes, multi core cables, other cables etc., that can be used one time or other at a later date and normally they are recovered from the cut-pieces of pipes, multi core cables cables, etc.

Non - Salvageable scrap means the lengths of tubes, pipes, multi core cables, other cables etc., and they are from cut-pieces of tubes, pipes, multi core cables, other cables etc., that cannot be used at all one time or other.

**4.4.11 The rates of laying for LT Power, control & Signal cables is inclusive of glanding and termination at both ends. Glands shall be supplied by BHEL & Lugs above 4 sq mm shall be supplied by BHEL. Lugs upto 4 sq mm shall be in vendor's scope, which is inclusive in laying Rates. The Unit rates for HT cable termination are exclusive of Unit rates for laying. Glands & Termination Kits for HT Cables ( 3.3 KV & above) shall be supplied by BHEL.**

4.5.0 For any items or class of work not specified herein but required for total completion of work, the same shall be carried out as per BHEL requirement. However, payment of these items/class of work shall be regulated on the basis of rate arrived at by either of the following methods:

- A) Based on rate of identical/similar items in the rate schedule.
- B) Based on the rate arrived from nearby items in the rate schedule.
- C) Wherever any item rate for similar type of work or nearby item rate does not exist in the rate schedule, rate will be worked out on the basis of work element or from fundamentals of estimation.

Contractor shall provide necessary resources for completion of such work within the stipulated time schedule. Value of such work shall be included while computing the total value of work finally executed for all contractual purposes, particularly for contract variation purpose.

4.6.0 The contractor's scope of work is further described in the clauses hereafter:

Described in detail in section-16 .

#### **4.6.2 STRUCTURAL STEEL FABRICATION AND INSTALLATION**

##### **A INSTRUMENT/ JUNCTION BOX FRAME/ CABLE TRAY & MISC STRUCTURES FABRICATION**

1. Structural steel material like MS angles, channels, beams, flats, plates etc. shall be supplied in running meter and the same shall be used for fabrication of panel base frame, canopies for instruments/panels/ drives/JB/push buttons etc., instrument/junction box frames, impulse pipe/instrument air pipe supports and instruments etc.
2. This shall include cutting to size, contouring of ends for connections if required, welding, grinding of excess weld deposits/burrs, drilling of holes for mounting of device/instrument, installation at location, levelling, alignment, providing bracings and painting etc. No gas cut holes will be permitted. All paints, primers, etc are in the scope of the contractor.
3. All the fabricated supports/frames shall be painted as per painting specifications.
4. Frame installation at site may involve mounting either on concrete floor by grouting/using anchor fasteners or on steel structure by welding etc. All consumables including anchor fasteners shall be arranged by the contractor. Where required, as part of work, concrete floors may have to be chipped out to reinforcement depth for anchoring the frames. Wherever grouting is required, contractor shall arrange all the required material including cement/grout mix, shuttering etc., necessary labour and meet all other requirements as part of work.
5. In case, structural cable trays, bends, tees, reducers etc., are required to be fabricated from structural steel and installed, unit rate applicable for fabrication and installation of structural steel shall be applicable in such instances.
6. In certain packages, members of frames/rack for mounting of junction boxes/ instruments may be supplied readymade. These have to be assembled prior to installation. The installation rate as quoted shall include assembly of the frames.
7. Gas cutting of tray/impulse pipe support and holes in frame is not permitted. Only hacksaw cutting/ drilled hole shall be permitted

## B CABLE TRAY SUPPORT

1. GI Structural material shall be supplied in standard length. The support member required for typical installation to be cut suit to site / lay out requirement from the straight length. Tray supporting members to be installed for typical installation as indicated in sectional arrangement of cable tray route plan. BHEL's customer shall provide projected dowels embedded in cable trenches for welding of supports. The support shall be either bolted or welded type as per drg. No cutting by gas shall be permitted.
2. Wherever supports needs to fixed on concrete slabs or ceiling with anchor fastener, and anchor fastener shall be arranged by contractor as part of work.
3. All galvanization damaged due to cutting / welding operation required to be carried out for the installation of cable support system shall be made good with application of cold galvanization paint (to be arranged by the contractor at his cost) immediately after completion of welding.

### 4.6.3 CABLE LAYING (POWER/CONTROL/INSTRUMENTATION CABLES/PLUG-IN CABLES/INTRA-PLANT BUS/DATA SHIELDED CABLES/ARMOURED/UN-ARMOURED, SINGLE/MULTI-CORE, HIGHWAY, PVC/HR PVC/FRLS/TEFFLON/XLP INSULATION)

1. Cable lengths include cutting to the required length, laying in overhead/underground cable trench/through pipes/flexible conduits, dressing/clamping in tray, drilling of holes in gland plates in panels and junction box, glanding, splicing, dressing of spliced wire inside the panel and JB's, providing printed ferrules (**contractor to arrange ferrule printing machine(s) as required**), termination by using crimp type copper tinned/aluminium lugs, insulated/un-insulated, crimp and soldering termination, plug-in connections with insert type crimping, providing identification cable tags, PVC/aluminium at both the ends and at appropriate interval throughout the route length, continuity checking, insulation resistance checking, high voltage test on HT cables.
2. Entry to the panels, JB's may be at top, side or bottom. All cables are required to be supported and clamped near to the panel.
3. Wherever cable glanding is not possible, either due to the gland plate size limitations or more number of cable entries, pre-fab plug-in cables, for such cases, cables may have to be lifted inside the panel either making cut-out in gland plate and providing rubber profile for sharp edge protection or alternatively, provide 4/6" PVC pipe coupling gland and these pipe coupling gland shall be supplied by contractor within the quoted rate of cable laying.
4. Supply of copper tinned lugs conforming to IS: 694 of various types (pin, ring, fork, snap-on) upto 4 sq.mm, PVC cable ties, printable ferrules, PVC button and tapes, cable identification tag of PVC/metal, clamping and dressing material with hardware, PVC sleeves etc. shall be supplied by contractor within the quoted rate for cable laying. The quality and make of cable lugs shall be got approved from BHEL engineer prior to their use on job.
5. All care should be taken to avoid abrasion, tension, twisting, kinking, stretching of cables during installation.

6. Cable shielding – all signal cables are supplied with bare shielded copper wire/with braided wire shield, general sealed wire is kept isolated at instrument/field device end and continuity is maintained through JBs and getting earth at panel end only. While terminated the sealed wire either in panel or JBs, PVC sleeves is to be used to avoid two-point earthing.
7. Wherever cable runs through the duct, conduit, valves, the entry and exit points shall be sealed using fire/weather proof compound. In addition to this, cable entry in panels, MCC/HT/LT breakers, instruments, electrical actuators etc. are also required to be similarly sealed. **The required material for doing so shall be included by contractor in the cable laying.**
8. Many of the cable trays and cables have to be laid in cable trenches. For this purpose, the cover of the trenches have to be opened for working in site and whenever the cables are to be laid in existing cable tray, all safety precautions have to be observed.
9. After completing the work, the trenches have to be cleaned and covers put back into position. Contractor shall also carry out de-watering from the trenches if required and arrange pumps etc. at his cost.
10. Looping wire at terminal block of panels and electrical actuator as shown in the inter-connection diagram is to be done by contractor at no extra cost.
11. Contractor shall carefully plan the cutting schedule of each cable drum in consultation with BHEL site engineer such that wastages are minimised. Recovery will be made in case the wastages are exceeding the wastage allowances fixed in this contract.

**4.6.4 BELOW GROUND EARTHING :** Treated test pits, Test Links, Earth Electrodes, Column earth connections for various areas will be as per Drawing PE – DG-239 -509 –E004 Rev A sheet 01 TO 10, which is attached with these specifications. Earth rod 40 mm shall be issued from BHEL stores. **Supply of all other items including charcoal, salt, civil items is also in the scope of the contractor. Civil works are also to be carried out by the contractor.** The contractor shall also connect this pit to the earth grid (by other agency) at nominal distances of 3 to 5 meters by 40 mm rods, Details are given elsewhere in tender.

#### **4.6.5 Lightning Protection System :**

**The scope of work is to be carried out as per details given in Typical Details of lightning Protection System ( PE–DG-239-509-E05 ) sh 01 to 09 given in section - 16 as a attachment. The items are covered in Rate schedule. All Hardware (Bolts, Nuts washers etc,) required for fabricating Links shall be in the scope of contractor which is inclusive of item rate in Rate schedule at no extra cost to BHEL.**

#### **4.6.13 PAINTING**

**Colour Banding, Legend and Identification Marking, Direction Marking etc. shall be in scope of the contractor for all items under this scope of work .**

#### 4.6.13.1 STRUCTURALS

Structural components may be supplied without any primer/paint coat from shop. The surface of such items shall be cleaned as per specifications and then coated with two coats of ROZC (IS:2074) Primer. Supply of Primer, etc is included in the scope of the contractor.

#### 4.6.13.3 PANELS, JUNCTION BOXES

Panels and Junction Boxes shall be Touch-up painted as and where original shop paint is peeled off. Necessary surface cleaning and preparation shall be done by the contractor as per relevant painting codes followed by two coats of Primer and two coats of Finish Paint. All necessary paints, primers, etc are to be arranged by the contractor within the quoted rates.

#### **4.6. 14 Establishment OF OFFICE**

**The work under this scope being quite sophisticated and also quite extensive, for proper planning, monitoring, reporting, etc of ongoing works, the contractor shall establish his own computer(s) and printer(s) at his site office, along with suitable operator(s), consumables, etc. *Non-establishment of above equipment will attract penalty @ Rs 10000 (Rs Ten thousand only) per month.***

**BHEL uses its own software SOMS (Site Operation and Management System) for total project execution and billing. The contractor shall also provide adequate and suitable manpower for updating / entries into SOMS in BHEL computers at site.**

#### 4.6.15 Troubleshooting during plant operation

**During pre-commissioning / commissioning stages when the plant will be under various stages of operation, it will be necessary to have continuous (day and night) presence of suitable manpower along with required tools to attend to any defects etc that may arise during such operation. The contractor will be required to put such personnel in shifts. The bidder must also take this aspect into consideration.**

#### 4.6.16

Equipments/instruments etc., under the above scope of erection and commissioning are generally despatched from BHEL's manufacturing units / vendor's works at site well before start of erection. Sometimes, such despatched materials may get stuck up with transporters/railways. The contractor shall provide support / manpower for necessary chase up for removal of such bottlenecks in transportation. Also, for smaller items, it could be necessary to depute his person to personally carry certain items from works to site. Requirement of such activities which will be decided by BHEL engineer and chase up activities, if required, shall be performed under authorization by BHEL. The above services shall be provided without any additional price to BHEL.

## 4.7 EXCLUSIONS

The Following works are excluded from Vendor's Scope.

- a) Supply of cables.
- b) Supply of cable trays & accessories, structural steel, termination kits and straight through joints, cable glands, conduits, pipes, marshalling boxes. However, supply of these items shall be the scope of vendor if the same is covered under the scope in Section C and the technical requirements are covered in other specifications.
- c) Major civil works like excavation and concreting of concrete trenches, plate embedments on cable trenches, ceiling and floors.
- d) Civil works for ducting for crossing of roads & rail tracks.
- e) Conduits and pipes embedded in walls, floors etc.

As explained in section - 16

Note:

The aforesaid exclusions should not be construed as exhaustive. They are meant for general guideline. BHEL reserves the right to include or exclude any item which is required for completing the job as per rates indicated in rate schedule. Contractor should carry out all such jobs as per the instructions of BHEL engineer.

## Section-5

### Special Conditions of Contract

#### 5.0 Obligations of the Contractor (Tools, Tackles, Consumables etc.)

##### 5.1 Labour Colony

BHEL'S customer will provide the open land with single point for drinking water and electricity. Contractor shall make further arrangements for constructing the labour colony and including lighting, water distribution and suitable provisions of drainage/sanitation.

##### 5.2 Tools & Plants and MMD

###### 5.2.1

The contractor shall provide all required Tools and Plants, inspection, Measuring and Monitoring Devices (MMD), Handling & Transportation Equipments for the scope of work covered under these specifications in addition to the T&P indicated to be provided by BHEL in **Appendix-I**. An indicative list of major T&P and MMD to be deployed by the Contractor is given in the **Appendix-III**. It may be noted that this list does not intend to exhaustively cover the contractor's responsibility with regard to T&P to be deployed by him. BHEL will provide the services of their T & P listed in Appendix-I, free of charge, on sharing basis. Refer section-7 for further details with regard to BHEL's T&P.

###### 5.2.2

All tools and tackles to be deployed by the contractor for the work shall have the prior approval of BHEL engineer with regard to brand, quality and specification.

###### 5.2.3

Timely deployment of adequate quantity of T&P is the responsibility of the contractor. The contractor shall be prepared to augment the T&P at short notice to match the planned targets and to achieve the milestones.

###### 5.2.4

Contractor shall maintain and operate his tools and plants in such a way that major breakdowns are avoided. In the event of major breakdown, contractor shall make alternate arrangements expeditiously so that the progress of work is not hampered.

###### 5.2.5

In the event of contractor failing to arrange the required tools, plants, machinery, equipment, material or non-availability of the same owing to breakdown, BHEL will make the alternate arrangement at the risk and cost of the contractor.

###### 5.2.6

The T&P to be arranged by the contractor shall be in proper working condition. The operation shall not lead to unsafe condition. The movements of cranes, and other equipment should be such that no damage/breaking occur to foundation, equipment, material and men. All arrangements for the movement of his T&P etc, shall be the contractor's responsibility.

### 5.2.7

Normally, for welding only the use of welding generators/rectifiers will be permitted. The use of welding transformers will be subject to the approval of BHEL engineer.

### 5.2.8

The contractor at his cost shall carry out periodical testing of his construction equipments and calibration of measuring instruments (MMD) and tests. Test/calibration certificates shall be furnished to BHEL. MMD shall be calibrated only at accredited laboratory as per the list available with BHEL or any other laboratory approved by BHEL.

The contractor shall provide all the necessary steel scaffolding materials, temporary structures and necessary safety devices etc. during preassembly, calibration, erection, testing and commissioning of the equipment.

Contractor shall maintain and operate his tools, plants, calibrating instruments etc. in such a way that major breakdowns are avoided. In the event of major breakdown, the contractor shall make alternate arrangements expeditiously so that the progress of the work is not hampered.

## 5.3 Consumables

### 5.3.1

The contractor shall provide all consumables required for carrying out the work covered under these specifications excepting those, which are specifically indicated as BHEL scope.

### 5.3.2

All consumables to be used for the work shall have prior approval of BHEL engineer with regard to brand and quality specifications. Test reports/ certificates in respect of these consumables, wherever applicable, shall be submitted to BHEL engineer.

### 5.3.3 Primers, Paints etc.

The contractor shall provide Primer (ROZC as per IS:2074), Synthetic Enamel Paint (IS:2932) and Aluminum Paint – as necessary for respective painting area for the scope of painting work indicated in Section-4 as well as for protection of site weld joints and gas cut locations. Contractor shall also arrange to provide the required thinner and other consumables, T&P and implements etc. required for application of Primer and Paints. All primers, paints and thinners shall be sourced by contractor only from BHEL approved manufacturers. Some of them are as listed under.

- 1) M/s Asian Paints
- 2) M/s Berger paints
- 3) M/s Jenson & Nicholson
- 4) M/s Shalimar Paints
- 5) Any other BHEL approved manufacturers.

## 5.4 Welding Electrodes, Filler Wires for MIG/TIG Welding and Gases

### 5.4.1

Contractor at his cost shall arrange all the required welding electrodes as approved by BHEL. It shall be the responsibility of the contractor to obtain prior approval of BHEL, regarding manufacturer, type and brand name of welding electrodes etc. On receipt of the electrodes at site, it shall be subject to inspection and approval by BHEL regarding type of electrodes, batch number, date of expiry etc. Batch test certificates shall be made available to BHEL for verification & records.

BHEL reserves the right to reject the use of any electrodes, if found non-acceptable because of bad quality, deterioration in quality due to improper storage, shelf-life expiry, unapproved type/brand etc

### 5.4.2

All the required gases for welding and gas cutting like Oxygen, Acetylene, Argon (welding quality), Nitrogen etc. shall be arranged by the contractor at his cost.

### 5.4.3

If at any time during the execution of work, it is noticed that the work is suffering on account of non-availability of consumables from the contractor's side BHEL will make alternate arrangements at the risk and cost of contractor. The expenditure incurred with overheads will be recovered from the contractor.

### 5.4.4 TEST PIECES FOR WELDERS QUALIFICATION TEST.

Materials for Test Pieces for qualification of structural welders shall be supplied by the Contractor. Contractor shall also prepare the test coupons from such materials. All expenses in respect of **welders' qualification test and Welding Process Qualification test** shall be to the contractors account.

## 5.5 Field Office

### 5.5.1

The contractor shall make his own arrangements for field office and stores for accommodating necessary equipments, tools room for execution of the work. Only open space will be provided by BHEL's customer free of charges within the project premises as per the availability of space.

### 5.5.2

On completion of work, all the temporary buildings, structures, pipelines, cables, etc shall be dismantled and leveled and debris shall be removed as per instruction of BHEL by the contractor at his cost. In the event of his failure to do so, the same will be arranged to be removed and expenditure thereof will be recovered from the contractor. The decision of BHEL engineer in this regard shall be final. However, the scope of dismantling and leveling the area is limited only to the contractor's site office, yard and other spaces occupied by the contractor.

## 5.6 Area Lighting

Contractor shall arrange adequate floodlights, hand lamps and area lighting. Provision of distribution lines for lighting from the single point to the required place with proper

distribution boards, observing the safety rules laid down by the electrical authorities of the state shall be done by the contractor including all the materials like cables, fuses, switch boards etc

## **5.7 CONSTRUCTION POWER & WATER**

### **5.7.1**

Construction power (three phase, 415v / 440v, 200 amps, 4-wire) will be provided at one point near the site approximately 500 Meters from erection site free of charge. However all taxes, duties, levies, charges etc, as applicable, shall also be born by the contractor. Presently no such charges are applicable. Accordingly, required energy meter, all cables, fuses, distribution boards, switches, switchboards, bus bars, earthing arrangements, protection devices e.g. ELCB, if any, and any other installation as specified by Statutory Authority, Client in this regard, for drawl of construction power shall be arranged by the contractor. Obtaining approvals, payment of necessary fees, duties etc towards the clearance of such installations, if any, prior to these being put to use or as may be specified, shall be the responsibility of the contractor.

### **5.7.2**

It shall be the responsibility of the contractor to provide, maintain the complete installation on the load side of the supply with due regard to the safety requirements at site. All cabling and installations shall comply in all respects with the appropriate statutory requirements. The installation and maintenance of this shall be done by licensed and experienced Electrician.

### **5.7.3**

The contractor shall install necessary Capacitor Bank etc. with appropriate control mechanism to maintain the Power Factor as per the guidelines in vogue from time to time in this regard. Any levy imposed by the customer / authority for any deviation in power factor shall be passed on to the contractor.

### **5.7.4**

Contractor shall be equipped with back-up power supply arrangement like DG set and diesel operated welding machine etc. to tackle situations arising due to failure of customer supplied power, so as to ensure continuity and completion of critical process that are underway at the time of power failure or important activities planned in immediate future.

### **5.7.5**

**The Contractor at his own cost shall arrange water for Construction purpose as well as drinking water. Customer/BHEL shall not provided any facility in this regard.**

### **5.7.6**

BHEL is not responsible for any loss or damage to the contractor's equipment as a result of variations in voltage or frequency or interruptions in power supply. Contractor shall take suitable insurance policy for such accidental loss/ damages.

## **5.8 Contract Labour**

### **5.8.1**

The contractor in the event of his engaging 10 or more workmen will obtain independent license under the Contract Labour (regulations and abolition) Act 1970 from the concerned authorities based on the certificate (form -V) issued by the principal employer/customer.

## 5.8.2 Provident Fund

Contractor will deduct the necessary amount from his employees towards provident fund and contribute equal amount as per government of India labour laws. Contractor regularly to the provident fund commissioner and get the account code will deposit this amount. Contractor shall submit the account code duly certified by pf commissioner to BHEL project in-charge.

## 5.8.3

Contractor shall also comply with the provisions of ESIS act in vogue and submit evidence thereof to BHEL site in-charge. All other expenses such as employees' benefits to be borne by the contractor as per the labour laws. Contractor shall produce necessary certificates towards their compliance with such statutes and payment of all statutory dues.

## 5.8.4

Contractor shall also comply with the requirements of local authorities/ project authorities calling for police verification of antecedents of the workmen, staff etc

## 5.8.5

Where applicable, provisions of workman compensation act shall be adhered to.

## 5.8.6

BHEL/customer may insist upon witnessing the regular payment to the labour. They may also like to verify the relevant records for compliance with statutory requirements. Contractor shall enable such facilities to BHEL/ Customer.

## 5.9 Taxes, Duties, Levies

Refer to Clause 2.8.4 of General Conditions of Contract. Notwithstanding anything contained therein, the following provisions shall be applicable for this contract.

### 5.9.1

The contractor shall pay all (save the specific exclusions as enumerated in this contract) taxes, fees, license charges, deposits, duties, tools, royalty, commissions or other charges which may be levied on the input goods & services consumed and output goods & services delivered in course of his operations in executing the contract. In case BHEL is forced to pay any of such taxes, BHEL shall have the right to recover the same from his bills or otherwise as deemed fit.

However, provisions regarding Service Tax and Value Added Tax (VAT) on output services and goods shall be as per following clauses.

### 5.9.2 Service Tax & Cess on Service Tax

Service Tax and Cess on Service Tax as applicable on output Services are excluded from contractor's scope; therefore contractor's price/rates shall be **exclusive** of Service Tax and Cess on Output Services. In case, it becomes mandatory for the contractor under provisions of relevant act/law to collect the Service Tax & Cess from BHEL and deposit the same with the concerned tax authorities, such applicable amount will be paid by BHEL. Contractor shall submit to BHEL documentary evidence of Service Tax registration and remittance record of such tax immediately after depositing the tax with

concerned authorities. Contractor shall obtain prior written consent from BHEL before billing the amount towards such taxes.

With introduction of Cenvat Credit Rules 2004, which came into force w.e.f. 10.09.2004, Excise Duty paid on Input Goods including Capital Goods and Service Tax paid on Input Services that are used for providing the output services can be taken credit of against the Service Tax payable on output services. However BHEL may opt for availing the abatement provision in which case cenvat credit may not be available on input duty.

### **5.9.3 VAT (Sales Tax /WCT)**

As regards Value Added Tax (VAT) on transfer of property in goods involved in Works Contract (previously known as Works Contract Tax) applicable as per local laws, the price quoted by the contractor shall be **exclusive** of the same. Where such taxes are required to be paid by the contractor, this will be reimbursed on production of proof of payment made to the authorities by the Contractor. In any case the Contractor shall register himself with the respective Sales Tax authorities of the state and submit proof of such registration to BHEL along with the first RA bill. The contractor has to take all necessary steps to **minimize tax on input goods** by purchasing the materials from any registered dealer of the concerned state only. In case contractor opts for composition, it will be with the prior express consent of BHEL. Deduction of tax at source shall be made as per the provisions of law unless otherwise found exempted. In case tax is deducted at source as per the provisions of law, this is to be construed as an advance tax paid by the contractor and no reimbursement thereof will be made unless specifically agreed to.

### **5.9.4 Modalities of Tax Incidence on BHEL**

Wherever the relevant tax laws permit more than one option or methodology for discharging the liability of tax/levy/duty, BHEL will have the right to adopt the appropriate one considering the amount of tax liability on BHEL/Client as well as procedural simplicity with regard to assessment of the liability. The option chosen by BHEL shall be binding on the Contractor for discharging the obligation of BHEL in respect of the tax liability to the Contractor.

### **5.9.5 New Taxes/Levies**

In case the Government imposes any new levy/tax on the output service/ goods/work after award of the contract, the same shall be reimbursed by BHEL at actual.

In case any new tax/levy/duty etc. becomes applicable after the date of Bidder's offer, the Bidder/Contractor must convey its impact on his price duly substantiated by documentary evidence in support of the same **before opening of Price Bid**. Claim for any such impact after opening the Price Bid will not be considered by BHEL for reimbursement of tax or reassessment of offer.

No reimbursement/recovery on account of increase/reduction in the rate of taxes, levies, duties etc. on input goods/services/work shall be made. Such impact shall be taken care of by the Price Variation/Adjustment Clause (PVC) if any. In case PVC is not applicable for the contract, Bidder has to make his own assessment of the impact of future variation if any, in rates of taxes/duties/ levies etc. in his price bid.

## **5.10 Submission of Periodical Reports**

Contractor shall submit periodical reports in respect of following aspects of operation:

- 1) Consumption of welding electrodes and gases
- 2) Consumption of construction power
- 3) Manpower reports
- 4) Progress reports – periodically
- 5) Field calibration reports

BHEL at site will inform formats for these reports.

## 5.11

It is the responsibility of the contractor to arrange gate pass for all his employees, T&P etc. Necessary coordination with customer officials is the responsibility of the contractor. Contractor to follow all the procedures laid down by the customer for making gate passes. Where permitted, by customer/ BHEL, to work beyond normal working hours, the contractor shall arrange necessary work permit for working beyond normal working hours.

## **5.12 ELECTRICAL INSPECTORATE'S APPROVAL /STATUTORY INSPECTION**

5.12.1 Contractor shall have/obtain valid Electrical Contractors License to carry out the Erection, Testing & Commissioning work on High/Low Voltage Electrical cabling earthing and lightning Protection System Equipments under scope of work from the appropriate statutory authority of the concerned state or Central Electricity Authority, as the case may be. All fees and expenses in this regard shall be in the contractor's account.

5.12.2 Contractor shall arrange inspection of concerned Statutory Authority for the installation, testing & commissioning of High / Low voltage cabling, earthing and lightning protection system covered under the scope of work in this tender specification and obtain their approval in appropriate format prior to charging of the equipments.

5.12.3 Contractor shall be responsible for all necessary liaisoning work with Statutory Authority towards the certification of installation / works. BHEL will pay Statutory Fees in respect of inspection of installations as per demand note/challan issued by the statutory authority. All other expenses shall be borne by the Contractor. BHEL/ BHEL's Customer shall be providing technical assistance, drawing & document for submission to Statutory Authority. Contractor shall provide all logistics services in this regard.

## **Section-6**

### **Special Conditions of Contract**

#### **6.1 Contractor's Obligation with Regard to Employment of Supervisory Staff and Workmen**

The contractor shall deploy all the skilled/semiskilled/ unskilled labour including highly skilled workmen like high-pressure welders etc. These workmen should have previous experience on similar job. They shall hold valid certificates wherever necessary. BHEL reserves the right to insist on removal of any employee of the contractor at any time if he is found to be unsuitable and the contractor shall forthwith remove him. Contractor should furnish a tentative deployment plan of his manpower as required vide appendix-IV. Also the actual deployment will be so as to satisfy the erection and commissioning targets set by BHEL.

#### **6.2**

It is the responsibility of the contractor to engage his workmen in shifts and on overtime basis for achieving the targets set by BHEL. This target may be set to suit BHEL's commitments to its customer or to advance date of completion of events or due to other reasons. The decision of BHEL in regard to setting the erection and commissioning targets will be final and binding on the contractor.

#### **6.3**

Contractor shall deploy only qualified and experienced engineers/ supervisors. They shall have professional approach in executing the work.

#### **6.4**

The contractor's supervisory staff shall execute the work in the most professional manner in the stipulated time. Accuracy of work and aesthetic finish are essential part of this contract. They shall be responsible to ensure that the assembly and workmanship conform to dimensions and tolerances given in the drawings/instructions given by BHEL engineer from time to time.

#### **6.5**

The supervisory staff employed by the contractor shall ensure proper outturn of work and discipline on the part of the labour put on the job by the contractor. Also in general they should see that the works are carried out in a safe and proper manner and in coordination with other labour and staff employed directly by BHEL or other contractors of BHEL /customer.

#### **6.6 WATCH AND WARD**

Contractor has to arrange and provide watch and ward round the clock. Any theft or damage of component due to negligence of the contractor will have to be replaced/repared by the contractor. The areas are unit control/ESP control room and field.

#### **6.7 Industrial Relations and Labour Laws**

An industrial relations supervisor shall coordinate for the implementation of local labour laws, maintenance of records as required by contract labour (regulation and

abolition) act and also coordinate with the local labour authorities and any other such authorities under whom this work falls.

6.8

If at any time, it is found that the contractor is not in a position to deploy the required engineers/supervisors/workmen due to any reason, BHEL shall have the option to make alternate arrangements at the contractor's risk and cost.

### **6.9 Site Organization.**

Contractor shall employ only qualified and experienced engineers/supervisors for this job. They shall have professional approach in executing the work having adequate knowledge and experience in the fields of erection, erection methodology, calibration, testing and commissioning, quality control and quality assurance procedures, planning, safety etc., required to undertake the type of work as per this tender.

The contractor's supervisory staff shall execute the work in the most substantial and workmanlike manner in the stipulated time. Accuracy of work and aesthetic finish are essential part of this contract. They shall be responsible to ensure that the assembly and workmanship conform to dimensions and tolerances given in the drawings/instructions given by bhel engineer from time to time.

The supervisory staff employed by the contractor shall ensure proper outturn of work and discipline on the part of the labour put on the job by the contractor and in general, see that the works are carried out in a safe and proper manner in coordination with other labour and staff employed directly by BHEL or other contractors of BHEL or BHEL's client.

Contractor should provide a team of engineers with proven experience of erection, testing/ commissioning of electrical equipments as specified in tender specification. They shall be in a position to undertake specific assignments during the start up/ post start up/stabilization.

The contractor shall deploy adequate laboures and supervisory staff in the following areas.

- A) Overall planning, monitoring & control
- B) Equipments Erection
- C) Welding & NDT & Stress Relieving operators, induction.
- D) Testing & Commissioning
- E) Quality Control and Quality Assurance
- F) Materials Management
- G) Safety, Fire & Security
- H) Industrial Relations and Fulfillment of Labour Laws and Other Statutory Obligations.

Contractor shall furnish an organization chart indicating the staffing pattern for the above functions. Contractor shall provide the names and details of engineer/supervisors at the time of mobilization to BHEL as per the proposed organization chart.

## **Section-7**

### **Special Conditions**

#### **7.0 Obligations Of BHEL**

#### **7.1 Facilities Provided By BHEL**

#### **7.2 Space For Field Office**

Refer section-5 in this regard.

#### **7.3 Construction Water**

Refer section-5 in this regard.

#### **7.4 Construction Power**

Refer section-5 in this regard.

#### **7.5 Other Materials and Consumables:**

BHEL will supply consumables free of charges as listed in **Appendix-II**.

#### **7.6 Test Blanks (Plates & Pipes)**

Test pieces for qualification of structural welders shall be supplied by the Contractor.

#### **7.7 Filler Wire and Welding Electrodes**

All the welding consumables shall be arranged by contractor.

#### **7.8 Tools & Plants**

BHEL will provide the Tools & Plants listed in **Appendix—I** free of charges on sharing basis.

BHEL will also provide any special tools that are supplied by BHEL manufacturing units/vendors/suppliers as special installation tools under regular DU/DESS numbers in various product groups free to contractor. Contractor shall return these tools after the completion of the specific task for which such tools are intended, in good working order after proper servicing/overhauling.

## Section-8

### Special Conditions of Contract

#### 8.0 Inspection/Quality Assurance/Quality Control/ Statutory Inspection

- 8.1 Various inspection/quality control/quality assurance procedures/methods at various stages of erection and commissioning will be as per BHEL/customer quality control procedure/codes and other statutory provisions and as per BHEL engineer's instructions.
- 8.2 Preparation of quality assurance log sheets and protocols with customer/consultants/statutory authority, welding logs, NDE records, testing & calibration records and other quality control and quality assurance documentation as per BHEL engineer's instructions, is within the scope of work/specification. These records shall be submitted to BHEL/customer for approval from time to time.
- 8.3 A daily logbook of all measurements and testing/calibration should be maintained by contractor on the job for detailing inspection details of various equipments.
- 8.4 The performance of welders will be reviewed from time to time as per the BHEL standards. Welders' performance record shall be furnished periodically. Corrective action as informed by BHEL shall be taken in respect of those welders not conforming to these standards. This may include removal/ discontinuance of concerned welder(s). Contractor shall arrange for the alternate welders immediately.
- 8.5 All the welders shall carry identity cards as per the proforma prescribed by BHEL only welders duly authorized by BHEL/customer/consultant shall be engaged on the work.
- 8.6 Contractor shall provide all the measuring monitoring devices (MMDs) required for completion of the work satisfactorily. These MMDs shall conform to job requirement in respect of measurement range, accuracy level & any other specification. The indicative list of MMDs required for this work and to be made available by the contractor is given in appendix-III. The list will be reviewed by BHEL and the contractor shall meet any augmentation needed.
- 8.7 The MMDs deployed by the contractor shall, at all stages of work, have valid and current calibration. BHEL shall be done the calibration of these MMDs from the agencies accredited/ approved. Copy of calibration certificates in respect of these MMDs has to be submitted to BHEL. Periodical status report regarding validity of calibration has to be submitted to BHEL. Re-calibration/ re-validation shall be done periodically as per BHEL specifications. Contractor shall conform to the specifications of BHEL regarding storage of the MMDs.
- 8.8 Re-work necessitated on account of use of invalid MMDs shall be entirely to the contractor's account. He shall be responsible to take all corrective actions, including resource augmentation if any, as specified by BHEL to make-up for the loss of time.
- 8.9 In the course of work BHEL may counter/ finally check the measurements with their own MMDs. Contractor shall render all assistance in conduct of such counter/final measurements.
- 8.10 Total quality is the watchword of the work and contractor shall strive to achieve the quality standards, procedures laid down by BHEL. He shall follow all the

instructions as per BHEL drawings and quality standards. Contractor shall provide for the services of quality assurance engineer.

#### 8.11 Stage Inspection By FES/QA Engineers

Apart from day-to-day inspection by BHEL engineers stationed at site and also by customer's engineers, stage inspection of equipments under erection and commissioning at various stages of erection and commissioning by teams of engineers from field engineering services of BHEL's manufacturing units and quality assurance teams from field quality assurance factory quality assurance and commissioning engineers from technical services of BHEL will also be conducted. Contractor shall arrange all labour, tools and tackles etc, for such stage inspections as part of work.

#### 8.12 Statutory Inspection of Work:

#### 8.13 Statutory Inspection of Work

##### 8.13.1

The work to be executed under these specifications has to be offered for inspection, at appropriate stages of work completion, to various statutory authorities for compliance with applicable regulations.

##### 8.13.2

The work related statutory inspections, though not limited to, are as under:

- 1) Inspectorate of the Chief Electrical Inspector of Maharashtra OR Central Electricity Authority as per statute.
- 2) Any other authority connected to this work.

The scope includes getting the approval of the installations from the statutory authorities, which includes arranging for inspection visits of statutory authority periodically as per BHEL engineer's instructions, submitting documents, radiographs etc. and following up the matter with them. Contractor shall also make all arrangements for offering the products/systems for inspection, as applicable, to the concerned authority.

##### 8.13.3

It shall be contractor's responsibility to obtain approval of statutory authorities, whenever applicable, for conducting any work which comes under the purview of these authorities.

##### 8.13.4

BHEL will pay fees for visits, inspection fees etc. of these statutory authorities. Please refer Section-5 for working arrangement for payment of fees in this regard. All other expenses shall be borne by the contractor. In case these inspections have to be repeated due to reasons attributable to the contractor and fees have to be paid again, the contractor has to pay such additional charges.

##### 8.13.5

It shall be the responsibility of contractor to obtain license from chief electrical inspector, Maharashtra for carrying out high voltage work. Contractor shall also comply with the provisions of the latest Electricity Act, including the amendments thereof.

#### 8.13.6

The contractors shall pay all fees connected with testing of his welders/workers and testing, inspection & calibration of his MMD and T&P.

#### 8.14.0

The quality management system of BHEL, Power Sector – Western Region (PSWR) has already been certified and accredited under ISO 9002 standards in this regard. The basic philosophy of the quality management system is to define the organizational responsibility, work as per documented procedures, verify the output with respect to acceptance norms, identify the non-conforming product/ procedure and take corrective action for removal of non-conformance specifying the steps for avoiding recurrence of such non-conformities, & maintain the relevant quality records. The non-conformities are to be identified through the conduct of periodical audit of implementation of quality systems at various locations/stages of work. Suppliers/vendors of various products/services contributing in the work are also considered as part of the quality management system. .as such the contractor is expected not only to conform to the quality management system of BHEL but also it is desirable that they themselves are accredited under any quality management system standard.

#### 8.15.0 Field Quality Assurance

Contractor shall carry out all activities conforming to the approved Field Quality Plan (FQP) as revised from time to time. Total quality shall be the watchword of the work and contractor shall strive to achieve the quality standards, procedures laid down by BHEL. He shall follow all the instructions as per BHEL drawings and quality standards. Contractor shall provide the services of quality assurance engineer as per the relevant clauses.

## Section-9

### Special Conditions of Contract

#### Safety, Occupational Health and Environmental Management

##### Introduction:-

BHEL PSWR has been certified for Environmental Management under ISO 14001:1996 standard and Occupational Health & Safety under OHSAS 18001 by DNV. In order to comply with the above standards, it shall be the endeavour of BHEL and all its subcontractors to meet and implement the requirements by following the guidelines issued under Environmental, Occupational Health and Safety Management (EHS) manual a copy of which will be available with the BHEL site-in-charge.

Contractor shall also enter into a "Memorandum of Understanding" as given in clause 9.9 in case of award of contract.

9.0 Responsibility Of The Contractor In Respect Of Safety Of Men, Equipment, Material And Environment.

9.1 The Contractor Shall

9.1.1 Abide by the Safety Regulations applicable for the Site/Project and in particular as mentioned in the booklet "Safe Work Practices" issued by BHEL. Contractors are also to ensure that their employees and workmen use safety equipments as stipulated in the Factories Act (Latest Revision) during the execution of the work. Failure to use safety equipment as required by BHEL Engineer will be a sufficient reason for issuance of memo, which shall become part of Safety evaluation of the contractor at the end of the Project. Also all site work may be suspended if it is found that the workmen are employing unsafe working practice and all the costs/losses incurred due to suspension of work shall be borne by contractor. A comprehensive list of National Standards from which the contractor can draw references for complying with various requirements under this section is given under 9.10

9.1.2 Hold BHEL harmless and indemnified from and against all claims, cost and charges under Workmen's Compensation Act 1923 and 1933 and any amendment thereof and the contractor shall be solely responsible for the same.

9.1.3 Abide by the Procedure governing entry/exit of the contractor's personnel within the Customer/Client premises. All the contractors' employees shall be permitted to enter only on displaying of authorized Photo passes or any other documents as authorised by the Customer/Client

9.1.4 Be fully responsible for the identity, conduct and integrity of the personnel/workers engaged by them for carrying out the contract work and ensure that none of them are ever engaged in any anti national activity

9.1.5 prepare a sign board giving the following information and display it near the work site:

Name of Contractor

Name of Contractor Site-in-charge & Telephone number

Job Description in short

Date of start of job

Date of expected completion

Name of BHEL Site-in-charge.

9.1.6 Abide by the rules and regulations existing during the contract period as applicable for the contractors at the Project premises.

9.1.7 Observe the timings of work as advised by BHEL Engineer-in-charge for carrying out the contract work.

## 9.2 SPECIAL CONDITIONS

### 9.2.1 Safety

#### 9.2.1.1 Safety Plan

Before commencing the work, contractor shall submit a "safety plan" to the authorised BHEL official. The safety plan shall indicate in detail the measures that would be taken by the contractor to ensure safety to men, equipment, material and environment during execution of the work. The plan shall take care to satisfy all requirements specified hereunder.

The contractor shall submit "safety plan" before start of work. During negotiations, before placing of work order and during execution of the contract, BHEL shall have right to review and suggest modifications in the safety plan. Contractor shall abide by BHEL's decision in this respect.

9.2.1.1 The contractor shall take all necessary safety precautions and arrange for appropriate appliances and/or as per direction of BHEL or it's authorised person to prevent loss of human lives, injuries to men engaged and damage to property and environment.

9.2.1.2 The contractor shall provide to his work force and also ensure the use of Personnel Protection Equipment (PPE) as found necessary and/or as directed and advised by BHEL officials without which permission is liable to be denied.

- Safety helmets conforming to IS 2925/1984 (1990)
- Safety belts conforming to IS 3521/1989
- Safety shoes conforming to IS 1989 part-II /1986(1992)
- Eye and face protection devices conforming to IS 2573/1986(1991), IS 6994 (1973), part-I (1991), IS 8807/1978 (1991), IS 8519/1977(1991).
- Other job specific PPE of standard ISI make as may be prescribed

9.2.1.3 All tools, tackles, lifting appliances, material handling equipment, scaffolds, cradles, cages, safety nets, ladders, equipment, etc used by the contractor shall be of safe design and construction. These shall be tested and certificate of fitness obtained before putting them to use and from time to time as instructed by authorised BHEL official who shall have the right to ban the use of any item found to be unsafe

9.2.1.4 All electrical equipment, connections and wiring for construction power, its distribution and use shall conform to the requirements of Indian Electricity Act and Rules. Only electricians licensed by the appropriate statutory authority shall be employed by the contractor to carryout all types of electrical works. All electrical appliances including portable electric tools used by the contractor shall have safe plugging system to source of power and be appropriately earthed.

9.2.1.5 The contractor shall not use any hand lamp energised by electric power with supply voltage of more than 24 volts. For work in confined spaces, lighting shall be arranged with power source of not more than 24 volts.

9.2.1.6 The contractor shall adopt all fire safety measures as per relevant Indian Standards

9.2.1.7 Where it becomes necessary to provide and/or store petroleum products, explosives, chemicals and liquid or gaseous fuel or any other substance that may cause fire or explosion, the contractor shall be responsible for carrying out such provisions and/or storage in accordance with the rules and regulations laid down by the relevant government acts, such as petroleum act, explosives act, petroleum and carbides of calcium manual of the chief controller of explosives, Government of India etc. The contractor in all such matters shall also take prior approval of the authorised BHEL official at the site.

9.2.1.8 Proper means of access must be used e.g. ladders, scaffolds, platforms etc. No makeshift access such as oil drums or pallets shall be used. Design of these will be in accordance with relevant standards and certified by competent persons before use.

9.2.1.9 Temporary arrangements made at Site for lifting, platforms, approach, access etc should be properly designed and approved before being put to use.

9.2.1.10 All excavations and openings must be securely and adequately fenced/barricaded and warning signs erected when considered necessary as per relevant code of practice.

9.2.1.11 No persons shall remove guardrails, covers or protective devices unless authorised by a responsible supervisor and alternative precautions have been taken.

9.2.1.12 Access ways, means of escape and fire exits shall be clearly marked, kept clear and unobstructed at all times

9.2.1.13 Only authorised persons holding relevant license will drive and operate site plant and equipments eg cranes, dumpers, excavators, transport vehicles etc.

9.2.1.14 Only authorised personnel are allowed to repair, commission electrical equipments.

9.2.1.15 Gas cylinders shall be handled and stored as per Gas Cylinder Rules and relevant safe working practices

9.2.1.16 All wastes generated at Site shall be segregated and collected in a designated place so as to prevent spillage/contamination/scattering at Site, until the waste is lifted for disposal to designated disposal area as advised by BHEL official.

9.2.1.17 The contractor shall arrange at his cost (wherever not specified) appropriate illumination at all work spots for safe working when natural day light is not adequate for clear visibility.

9.2.1.18 The contractor shall train adequate number of workers/supervisors for administering "FIRST AID". List of competent first aid administrators should be prominently displayed.

9.2.1.19 The contractor shall display at strategic places and in adequate numbers the following in fluorescent markings

- Emergency telephone numbers
- Exit, Walkways
- Safe working load charts for wire ropes, slings, D shackles etc
- Warning signs

9.2.1.20 The contractor shall be held responsible for any violation of statutory regulations (local, state or central) and BHEL instructions that may endanger safety of men, equipment, material and environment in his scope of work or other contractors or agencies. Cost of damage, if any, to life and property arising out of such violation of statutory regulations and BHEL instructions shall be borne by the contractor.

9.2.1.21 In case of a fatal or disabling injury/accident to any person at construction sites due to lapses by the contractor, the victim and/or his/her dependents shall be compensated by the contractor as per statutory requirements. However, if considered necessary, BHEL shall have the right to impose appropriate financial penalty on the contractor and recover the same from payments due to the contractor for suitably compensating the victim and/or his/her dependents. Before imposing any such penalty, appropriate enquiry shall be held by BHEL giving opportunity to the contractor to present his case.

9.2.1.22 In case of any damage to property due to lapses by the contractor, BHEL shall have the right to recover cost of such damages from payments due to the contractor after holding an appropriate enquiry.

9.2.1.23 In case of any delay in the completion of a job due to mishaps attributable to lapses by the contractor, BHEL shall have the right to recover cost of such delay from payments due to the contractor after notifying the contractor suitably and giving him opportunity to present his case.

9.2.1.24 If the contractor fails to improve the standards of safety in its operation to the satisfaction of BHEL after being given a reasonable opportunity to do so, and/or if the contractor fails to take appropriate safety precautions or to provide necessary safety devices and equipment or to carry out instructions regarding safety issued by the authorised BHEL official, BHEL shall have the right to take corrective steps at the risk and cost of the contractor after giving a notice of not less than seven days indicating the steps that would be taken by BHEL.

#### 9.2.1.25 **Emergency Response**

9.2.1.15.1 BHEL will have an Emergency Response Plan for each Project Site in consultation with the Owner as the case may be, detailing the procedure for mobilization of personnel and equipment, and defining the responsibilities of the personnel indicated, in order to prepare for any emergency that may arise in order to ensure the priorities of

- Safeguard of life
- Protect assets under construction or neighbouring
- Protect environment
- Resumption of normal operations as soon as the emergency condition is called off

All Contractors shall also be part of the Emergency response Plan and the personnel so nominated shall be aware of their duties and responsibilities in an emergency response situation.

9.2.1.15.2 At least 5% Contractors supervisors and workmen shall undergo training in administering 'First Aid'. The trained persons should represent for all categories of work and for all areas of work. Adequate number of trained persons should be available for each shift. These first aid personnel shall be included in the emergency response team. Contractor employees and workmen are encouraged to participate in first aid training programmes whenever organised by BHEL.

### **9.2.2 OCCUPATIONAL HEALTH**

9.2.2.1 Specific occupational health hazards will be identified through the hazard evaluation processes in consultation with BHEL engineers and the necessary prevention/reduction/elimination methods implemented.

9.2.2.2 All personnel working in an activity with a potential risk to health shall be made aware of all those risks and the actions they must take to reduce/control/eliminate the risk

9.2.2.3 Safety coordinator shall conduct periodic checks to ensure that every group of workers engaged in similar activities are aware of potential risks to health and the actions required to be taken to mitigate the risk

9.2.2.4 In order to protect personnel from associated health hazards, the following main areas will be focussed

- Issue of approved Personnel Protective Equipment
- Verification that the PPEs are adequate/maintained and worn by all staff involved in operations that are potentially hazardous to their health
- Ensure that the personnel deployed are physically fit for the operation/work concerned
- Provide hygienic and sanitary working conditions

9.2.2.5 Contractor workers employees engaged in noise risk areas shall be issued with hearing protection aids and the use of the same will be enforced. Further, these workers will be educated on the hazards of noise

9.2.2.6 Contractor workers engaged in dust environment shall be issued with necessary dust protection aids and the use of the same shall be enforced

9.2.2.7 Workers engaged in exposure to bright light/rays as in welding or radiation shall be issued with eye protection devices and the use of the same shall be enforced

9.2.2.8 Adequate arrangements shall be made to provide safe drinking water

9.2.2.9 Health monitoring records on at least sample basis for contractor employees & workmen shall be maintained for persons engaged in specified categories of work. These shall include

- Noise induced hearing loss
- Lung Function test
- Ergonomic Test
- Eye Test for Welders, Grinders, Drivers etc

### **9.2.3.0 HYGIENE and HOUSEKEEPING**

9.2.3.1 Good house keeping and proper hygiene is one of the key requirements of Occupational Health Safety and Environment management. Towards this the contractor shall encourage his workers and supervisors to maintain cleanliness in their area of work.

9.2.3.2 The Contractor shall arrange to place waste bins/chutes at convenient locations for the collection of scrap and other wastes. The bins shall be clearly marked and segregated for metal, non-metal, hazardous and non hazardous wastes.

9.2.3.3 BHEL may take up appropriate remedial measures at the cost of the contractors if the contractors fails in good house keeping and if there is an imminent risk of pollution

### **9.2.4 ENVIRONMENT MANAGEMENT**

9.2.4.1 BHEL has a sound environmental management system, which is to be maintained and implemented by all the contractors. The system allows for project specific objectives to be set and developed sensitive to client requirements, applicable environmental legislation and BHEL's own objectives and policy. BHEL engineers will assess and monitor the environmental impact of their work and lay out objectives for their minimisation. The contractors shall implement the objectives for continual improvement of environmental performance. BHEL shall regularly audit environmental impacts and their improvements.

#### **9.2.4.2 WASTE MANAGEMENT**

9.2.4.3.1 The objective of waste management is to ensure the safe and responsible disposal of waste, ensuring that it is correctly disposed of and being able to audit the process to ensure compliance.

9.2.4.3.2 Chemical wastes if any shall be collected separately and disposed of to BHEL designated refuse yard as per BHEL advise

9.2.4.3.3 No dangerous chemicals, noxious waste products or materials will be disposed off on or off site without approval obtained through BHEL.

9.2.4.3.4 All disposal of wastes generated during construction shall be in accordance with all relevant legislation.

9.2.4.3.5 Acid and alkali cleaning wastes shall be neutralized to acceptable norms before disposal to the designated area.

9.2.4.3.6 All necessary measures shall be taken to ensure safe collection and disposal of waste oils. In particular to ensure the prevention of their discharge into surface waters, ground waters, coastal waters or drainages

### **9.3 SUPERVISION**

9.3.1 Contractor must provide at least one full time on site safety coordinator when the manpower engaged is in excess of 50 for the contract activities in the premises. If the manpower is less than 50, the on site safety coordination responsibilities shall be assumed by any one of the contractor's other supervisory staff; however in both the cases, the contractor must specify in writing the name of such persons to the BHEL Engineer in Charge.

9.3.2 Contractor's safety coordinator or his supervisor responsible for safety as the case may be shall conduct at his work site, and document formal safety inspection and audits at least once in a week. Such documents are to be submitted to BHEL Engineer in Charge for his review and record

9.3.3 Contractor, supervisor must attend all schedule safety meetings as would be intimated to him by the BHEL Engineer in Charge.

9.3.4 Before starting work under any contract, the contractor must ensure that a job specific safety procedures/field practices as required over and above the safety permit conditions are prepared and followed .He should also ensure that all supervisors and workers involved understand and follow this procedures /field practices.

9.3.5 Contractor must ensure that in his work site appropriate display boards are put displaying signs for site safety, potential hazards and precautions required

#### 9.4.0 **TRAINING & AWARENESS**

9.4.1 Contractor shall deploy experienced supervisors and other manpower that are well conversant with the safety and environment regulations of the Project. The electricians to be deployed on the job should have wireman license.

9.4.2 All Supervisors & Workmen of the Contractor shall undergo Fire safety training/demonstration whenever arranged by BHEL with the help of either Customer's Fire and Safety department or outside faculty so as to acquire knowledge of fire prevention and also to be able to make use of appropriate fire extinguishers.

9.4.3 Contractor must familiarize himself from BHEL Engineer in Charge about all known potential fire, explosion or toxic release hazards related to the contract. He in turn will ensure that same information has been passed to the supervisors and workmen

9.4.4 Contractor must ensure that all his supervisors are properly trained and each employee has received and understood from his supervisor necessary training and briefing about the safety requirement. Necessary document as a means to verify that employees have understood the training is to be maintained.

9.4.5 The contractor supervisors shall also give a small safety briefing to all the workmen under his charge before undertaking any new work and specially understand the safety requirements that are mandatory

#### 9.5.0 **REPORTING**

9.5.1 The contractor shall submit report of all accidents, fires and property damage, dangerous occurrences to the authorized BHEL official immediately after such occurrence but in any case not later than twelve hours of the occurrence. Such report shall be furnished in the manner prescribed by BHEL and also to meet statutory requirement.

9.5.2 Any injury sustained by any of the contractor's employees within the Project premises must be reported to BHEL supervisor and FIRST AID should be immediately administered. The Contractor shall be responsible for keeping and maintaining proper records of Accidents to his personnel.

9.5.3 Contractor must arrange to immediately investigate, properly document and report any injury, accident or near miss involving any of his employees and take appropriate follow up action. He must furnish within 12 hours of the incident a written report to BHEL Engineer in charge and the Safety Section.

9.5.4 According to the Factory Act and the Employees state Insurance Act & regulation, any person sustaining any injury within the project premises and absenting himself from work for more than 46 hours, his accident report has to be sent to the respective Government Authorities. Therefore contractor shall inform the owner's representative such matter immediately for their needful action.

9.5.5 In addition, contractor shall submit periodic reports on safety to the authorised BHEL official from time to time as prescribed.

9.5.6 Before commencing the work, the contractor shall appoint/nominate a responsible officer to supervise implementation of all safety measures and liaison with his counterpart of BHEL.

**9.6 AUDIT REVIEW AND INSPECTION**

9.6.1 BHEL shall conduct audit on the contractor performance and compliance with the project specific requirements of the Environment and Occupational Health & Safety Management systems. The programme of audit shall cover all activities under the contract but will focus particularly on high-risk activities. The Construction Manager shall decide the schedule of audit. The audit findings shall be communicated to the contractors and necessary remedial action as advised by BHEL Engineers shall be under taken within the stipulated time.

9.6.2 Inspections shall be carried out regularly by the contractors and by BHEL engineers on activities, facilities, equipment and documentation to cover the following aspects.

- Compliance with procedures and systems
- Availability, condition and use of PPE
- Condition of maintenance tools, equipments, facilities
- Availability of fire fighting equipments and its condition
- Use of fire fighting equipments and first aid kit
- Awareness of occupational health hazard
- Awareness of safe working practices
- Presence of quality supervision
- Housekeeping

The Safety Co-coordinator shall visit and inspect work sites daily. All unsafe acts, unsafe conditions that have imminent potential for causing harm/injury/damage will be immediately corrected. He shall maintain a daily logbook giving details of unsafe acts or conditions observed and the corrective action taken and recommendations for preventing recurrence. Adequacy of corrective actions will be verified

The contractor shall take remedial measures as per the findings of each inspection. Besides the above, the contractor shall be required to carry out the following inspections.

SN	Equipment	Scope of inspection	Inspection by	Schedule
1	Hand tools	To identify unsafe/defective tool	User	Daily
2	Power tools	To identify unsafe/defective tool	User	Daily
3	Fire Extinguishers	To check pressure and any defect	User Safety Coordinator	Daily Every month
4	Lifting equipment/tackles	To check for defects and efficacy of	User	Daily

		brakes	Third party	Every Year
5	PPE	To check for defects	User	Daily

**9.7 NON COMPLIANCE:-**

9.7.1 NONCONFORMITY OF SAFETY RULES AND SAFETY APPLIANCES WILL BE VIEWED SERIOUSLY AND THE BHEL HAS RIGHT TO IMPOSE FINES ON THE CONTRACTOR AS UNDER **for every instance of violation noticed:**

Sl. No.	Violation of Safety Norm	Fine (in Rs)
01	Not Wearing Safety Helmet	50/-
02.	Not wearing Safety Belt	100/-
03.	Grinding Without Goggles	50/-
04.	Not using 24 V Supply For Internal Work	500/-
05.	Electrical Plugs Not used for hand Machine	100/-
06.	Not Sliding property	200/-
07.	Using Damaged Sling	200/-
08.	Lifting Cylinders Without Cage	500/-
09.	Not Using Proper Welding Cable With Lot of Joints And Not Insulated Property.	200/-
10.	Not Removing Small Scrap From Platforms	200/-
11.	Gas Cutting Without Taking Proper Precaution or Not Using Sheet Below Gas Cutting	200/-
12.	Not Maintaining Electric Winches Which are Operated Dangerously	500/-
13.	Improper Earthing Of Electrical T&P	500/-
14.	Accident Resulting in Partial Loss in Earning Capacity	25,000/- per victim
15.	Fatal Accident/Accidents Resulting in total loss in Earning Capacity	1,00,000/- per victim

Any other non-conformity noticed not listed above will also be fined as deemed fit by BHEL. The decision of BHEL engineer is final on the above. The amount will be deducted from running bills of the contractor. The amount collected above will be utilised for giving award to the employees who could avoid accident by following safety rules. Also the amount will be spent for purchasing the safety appliances and supporting the safety activity at site.

**9.8 CITATION:-**If safety record of the contractor in execution of the awarded job is to the satisfaction of safety department of BHEL, issue of an appropriate certificate to recognise the safety performance of the contractor may be considered by BHEL after completion of the job

## 9.9 Memorandum of Understanding

After Award Of Work, Contractors Are Required To Enter Into A Memorandum Of Understanding As Given Below:

### Memorandum of Understanding

**BHEL, PSWR is committed to Health, Safety and Environment Policy (EHS Policy) as given in the booklet titled “ Safe Working Practices” issued to all contractors.**

M/s \_\_\_\_\_ do hereby also commit to the same EHS Policy while executing the Contract Number \_\_\_\_\_

**M/s \_\_\_\_\_ shall ensure that safe work practices not limited to the above booklet are followed by all construction workers and supervisors. Spirit and content therein shall be reached to all workers and supervisors for compliance.**

BHEL will be carrying out EHS audits twice a year and M/s \_\_\_\_\_ shall ensure to close any non-conformity observed/reported within fifteen days.

Signed by authorised representative of M/s-----

Name :

Place & Date:

9.10.1 Comprehensive list of National Standards for reference and use wherever applicable in the execution of Civil, Erection and Commissioning Contracts

IS No.	YEAR	Amd. upto	Description
IS 10204	1982		PORTABLE FIRE EXTINGUISHERS MECHANICAL FOAM TYPE
IS 10245	1994		SPECIFICATION FOR BREATHING APPARATUS
IS 10291	1982		SAFETY CODE FOR DRESS DRIVERS IN CIVIL ENGINEERING WORKS
IS 10658	1983		HIGHER CAPACITY DRY POWDER FIRE EXTINGUISHERS (TROLLEY MOUNTED)
IS 10662	1992		COLOUR TELEVISION
IS 10667	1983		GUIDE FOR SELECTION OF INDUSTRIAL SAFETY EQUIPMENT FOR PROTECTION OF FOOT AND LEG
IS 11037	1984		ELECTRONIC FAN REGULATORS
IS 11057	1984		INDUSTRIAL SAFETY NETS
IS 11451	1998		RECOMMENDATION FOR SAFETY AND HEALTH REQUIREMENT RELATING TO OCCUPATION EXPOSURE TO ASBESTOS
IS 1169	1967		PEDESTAL FANS
IS 1179	1967		SPECIFICATION FOR EQUIPMENT FOR EYE AND FACE PROTECTION DURING WELDING
IS 11833	1986		DRY POWDER FIRE EXTINGUISHERS FOR METAL FIRES
IS 11972	1987		CODE OF PRACTICE FOR SAFETY PRECAUTION TO BE TAKEN WHEN ENTERING A SEWAGE SYSTEM
IS 1287	1986		ELECTRIC TOASTER
IS 13063	1991		STRUCTURAL SAFETY OF BUILDINGS ON SHALLOW FOUNDATIONS ON ROCKS

IS No.	YEAR	Amd. upto	Description
IS 13385	1992		SPECIFICATIONS FOR FIRE EXTINGUISHERS 50 LITRE WHEEL MOUNTED WATER TYPE ( GAS CARTRIDGES)
IS 13386	1992		SPECIFICATIONS FOR FIRE EXTINGUISHERS 50 LITRE MECHANICAL FOAM TYPE
IS 13415	1992		CODE OF SAFETY FOR PROTECTIVE BARRIERS IN AND AROUND BUILDINGS
IS 13416	1992		RECOMMENDATIONS FOR PREVENTIVE MEASURES AGAINST HAZARDS AT WORKING PLACE PART 1 TO PART 5
IS 13430	1992		CODE OF PRACTICE FOR SAFETY DURING ADDITIONAL CONSTRUCTION AND ALTERATION TO EXISTING BUILDINGS
IS 13849	1993		PORTABLE FIRE EXTINGUISHERS DRY POWDER TYPE ( CONSTANT PRESSURE)
IS 1446	1985		CLASSIFICATION OF DANGEROUS GOODS (FIRST REVISION)
IS 1476	1979		REFRIGERATORS
IS 1641	1988		CODE OF PRACTICE FOR FIRE SAFETY OF BUILDINGS (GENERAL): GENERAL PRINCIPLES OF FIRE GRADING AND CLASSIFICATION
IS 1642	1989		CODE OF PRACTICE FOR FIRE SAFETY OF BUILDINGS- DETAILS OF CONSTRUCTION
IS 1643	1988		CODE OF PRACTICE FOR FIRE SAFETY OF BUILDINGS (GENERAL): EXPOSURE HAZARD
IS 1646	1997		CODE OF PRACTICE FOR FIRE SAFETY OF BUILDINGS (GENERAL): ELECTRICAL INSTALLATIONS
IS 1904	1986		CODE OF PRACTICE FOR DESIGN AND CONSTRUCTION OF FOUNDATIONS IN SOIL
IS 1905	1987		STRUCTURAL SAFETY OF BUILDINGS MASONARY WALLS
IS 2082	1985		ELECTRICAL GEYSERS
IS 2171	1985		PORTABLE FIRE EXTINGUISHERS DRY POWDER TYPE (CARTRIDGE)
IS 2309	1989		PRACTICE FOR THE PROTECTION OF BUILDINGS AND ALLIED BUILDINGS AGAINST LIGHTENING
IS 2312	1967		EXHAUST FANS
IS 2361	1994		SPECIFICATION FOR BUILDING GRIPS - FIRST REVISION
IS 2418	1977		TUBULAR FLUORSCENT LAMPS IS 2418 (FT-1)
IS 2750	1964		STEEL SCAFFOLDINGS
IS 2762	1964		SAFE WORKING LOADS IN KGS FOR WIRE ROPE SLINGS
IS 2878	1986		FIRE EXTINGUISHERS CARBON DIOXIDE TYPE (PORTABLE AND TROLLEY MOUNTED)
IS 2925	1984		SPECIFICATION FOR INDUSTRIAL SAFETY HELMETS
IS 3016	1982		CODE OF PRACTICE FOR FIRE PRECAUTIONS IN WELDING AND CUTTING OPERATIONS- FIRST REVISION
IS 3315	1974		DESERT COOLERS
IS 3521	1989		INDUSTRIAL SAFETY BELTS AND HARNESS
IS 368	1983		IMMERSION WATER HEATERS
IS 3696	1991		SAFETY CODE OF SCAFFOLDS AND LADDERS PART 1 TO 2
IS 3737	1996		LEATHER SAFETY BOOTS FOR WORKERS IN HEAVY METAL INDUSTRIES

IS No.	YEAR	Amd. upto	Description
IS 374	1979		CEILING FANS INCLUDING REGULATORS
IS 3764	1992		EXCAVATION WORK - CODE OF SAFETY
IS 3786	1983		METHOD FOR COMPUTATION OF FREQUENCY AND SEVERITY RATES FOR INDUSTRIAL INJURIES AND CLASSIFICATION OF INDUSTRIAL ACCIDENTS
IS 3935	1966		CODE OF PRACTICE FOR COMPOSITE CONSTRUCTION
IS 4014	1967		CODE OF PRACTICE FOR STEEL TUBULAR SCAFFOLDING
IS 4081	1986		SAFETY CODE FOR BLASTING AND RELATED DRILLING OPERATIONS
IS 4082	1977	1996	STACKING AND STORAGE OF CONSTRUCTION MATERIALS AND COMPONENTS AT SITE
IS 4130	1991		DEMOLITION OF BUILDINGS - CODE OF SAFETY PART 1 TO 2
IS 4138	1977		SAFETY CODE FOR WORKING IN COMPRESSED AIR (FIRST REVISION)
IS 4155	1966		GLOSSARY OF TERMS RELATING TO CHEMICAL AND RADIATION HAZARDS AND HAZARDOUS CHEMICALS
IS 4209	1967		CODE OF SAFETY FOR CHEMICAL LABORATORY
IS 4250	1980		FOOD MIXERS
IS 4262	1967		CODE OF SAFETY FOR SULFURIC ACID
IS 4756	1978		SAFETY CODE FOR TUNNELING WORK
IS 4912	1978		SAFETY REQUIREMENTS FOR FLOOR AND WALL OPENINGS, RAILINGS AND TOE BOARDS
IS 5121	1969		SAFETY CODE FOR PILING AND OTHER DEEP FOUNDATIONS
IS 5182	1969	1982	METHODS FOR MEASUREMENT OF AIR POLLUTION
IS 5184	1969		CODE OF SAFETY FOR HYDROFLUORIC ACID
IS 5216	1982	2000	RECOMMENDATIONS ON SAFETY PROCEDURES AND PRACTICE IN ELECTRICAL WORK PART I AND II
IS 555	1979		TABLE FANS
IS 5557	1995		INDUSTRIAL AND SAFETY LINED RUBBER BOOTS (SECOND REVISION)
IS 5916	1970		SAFETY CODE FOR CONSTRUCTION INVOLVING USE OF HOR BITUMINOUS MATERIALS
IS 5983	1980		SPECIFICATION FOR EYE PROTECTORS - FIRST REVISION
IS 6234	1986		PORTABLE FIRE EXTINGUISHERS WATER TYPE (STORED PRESSURE)
IS 692	1994		CRITERIA FOR SAFETY AND DESIGN OF STRUCTURES SUBJECTED TO UNDERGROUND BLASTS
IS 6994	1973		SPECIFICATION FOR SAFETY GLOVES
IS 7155	1986		CODE OF RECOMMENDED PRACTICE FOR CONVEYOR SAFETY (PART 1 TO 8)
IS 7205	1974		SAFETY CODE FOR ERECTION OF STRUCTURAL STEEL WORK
IS 7293	1974		SAFETY CODE FOR WORKING WITH CONSTRUCTION MACHINERY
IS 7323	1994		GUIDELINES FOR OPERATIONS OF RESERVOIRS
IS 7812	1975		CODE OF SAFETY FOR MERCURY
IS 7969	1975		SAFETY CODE FOR HANDLING AND STORAGE OF BUILDING MATERIALS
IS 8089	1976		CODE OF SAFE PRACTICE FOR LAYOUT OF OUTSIDE

IS No.	YEAR	Amd. upto	Description
			FACILITIES IN AN INDUSTRIAL PLANT
IS 8091	1976		CODE OF PRACTICE FOR INDUSTRIAL PLANT LAYOUT
IS 8095	1976		ACCIDENTS PREVENTION TAGS
IS 818	1968	1997	CODE OF PRACTICE FOR SAFETY AND HEALTH REQUIREMENTS IN ELECTRIC AND GAS WELDING, AND CUTTING OPERATIONS
IS 8448	1989		AUTOMATIC LINE VOLTAGE CORRECTOR (STABILISER)
IS 8519	1977		GUIDE FOR SELECTION OF INDUSTRIAL SAFETY EQUIPMENT FOR BODY PROTECTION
IS 8520	1977		GUIDE FOR SELECTION OF INDUSTRIAL SAFETY EQUIPMENT FOR EYE, FACE AND EAR PROTECTION
IS 875	1987		STRUCTURAL SAFETY OF BUILDING: LOADING STANDARD PART 1 TO 5
IS 8807	1978		GUIDE FOR SELECTION OF INDUSTRIAL SAFETY EQUIPMENT FOR PROTECTION OF ARMS AND HANDS
IS 8978	1985		INSTANTANEOUS WATER HEATERS
IS 8989	1978		SAFETY CODE FOR ERECTION OF CONCRETE FRAMED STRUCTURES
IS 940	1989		PORTABLE FIRE EXTINGUISHERS WATER TYPE (GAS CARTRIDGE)
IS 9457	1980		SAFETY COLOURS AND SIGNS
IS 9679	1980		CODE OF SAFETY FOR WORK ENVIRONMENTAL MONITORING
IS 9706	1997		CODE OF PRACTICE FOR THE CONSTRUCTION OF AERIAL RPEWAYS FOR THE TRANSPORTATION OF MATERIAL
IS 9759	1981		GUIDELINES FOR DEWATERING DURING CONSTRUCTION
IS 9815	1989		SERVO MOTOR OPERATED LINE VOLTAGE CORRECTOR (SERVO STABILISER)
IS 9944	1992		RECOMMENDATIONS ON SAFE WORKING LOAD FOR NATURAL AND MAN-MADE FIBRE ROPE SLINGS
IS 996	1979		SINGLE PHASE ELECTRIC MOTORS
ISO 3873	1977		SAFETY HELMET

## SECTION-10

### SPECIAL CONDITIONS OF CONTRACT

#### 10.0 DRAWINGS AND DOCUMENTS

- 10.1 The detailed drawings, specifications available with BHEL engineers will also form part of this tender specification. Revision of drawings/documents may take place due to various considerations as is normal in such large project. Work will have to be carried out as per revised drawings/ documents. These documents will be made available to the contractor during execution of work at site.
- 10.2 One set of necessary drawings/documents to carry out the erection work will be furnished to the contractor by BHEL on loan that shall be returned to BHEL after completion of the work. Contractor's personnel shall take care of these documents given to them.
- 10.3 The data furnished in various sections and appendices and the drawings enclosed with this tender specification describe the equipment to be installed, tested and commissioned under this specification, briefly. However, the changes in the design and in the quantity may be expected to occur as is usual in any such large scale of works.
- 10.4 If any error or ambiguity is discovered in the specification/information contained in the documents/drawings and tender, the contractor shall forthwith bring the same to the notice of BHEL before submission of offer.
- 10.5 In case an ambiguity is detected after award of work, the same must be brought to the notice of BHEL before commencement of the work/activity. BHEL's interpretation in such cases will be final and binding on the contractor.
- 10.6 In case of any conflict between General Instructions to Bidders, General Conditions of Contract contained in Sections 1 & 2 respectively and Special Conditions of Contract contained in Sections 4 to 15 and Appendices, provisions contained in Special Conditions of Contract in Sections 4 to 15 and Appendices shall prevail.
- 10.7 In case of discrepancy between quoted item rate and corresponding amount in the rate schedule, the **quoted item rates shall be reckoned as correct and amount recalculated**. Quoted item rates shall also prevail for arriving at the total price quoted for offer evaluation and Work Order placement.
- 10.8 Bank Guarantees to be furnished by the contractor towards Security Deposit and Performance Guarantee (last 5% payment against workmanship warranty/defect liability) shall have a claim period of six months over and above the validity period required for the respective cases. BG for advance payment shall be kept valid for a period of two more months beyond the recovery period of the advance with interest thereof.

# Special Conditions of Contract

## Section-11

### 11.0 Time schedule - Contract Variation - Progress etc.

#### 11.1 TIME SCHEDULE & MOBILIZATION

##### 11.1.1 INITIAL MOBILIZATION AND TENTATIVE SCHEDULE

Contractor shall reach site, make his site establishment and be ready to commence the work **within two weeks** from the date of fax Letter of Intent (LOI) or as per directions of construction manager of BHEL.

The contractor has to subsequently augment his resources in such a manner that the entire work is completed to achieve the following tentative schedule:

SN	Activity	Tentative schedule unit -3	Tentative schedule unit -4
01	Mobilisation Of Contractor	JAN,08	-
02	Boiler Hydro Test	FEB,08	JUNE,08
03	Boiler light up and ABO	JULY,08	NOV,08
04	Turbine box-up	MAR,08	JULY,08
05	Steam blowing of completion	SEPT,08	JAN, 09
06	Turbine Oil flushing completion	MAY , 08	AUG ,08
07	Synchronisation and coal firing	SEPT,08	JAN, 09
08	Trial Operation	NOV,08	MAR,09
09	PG test	FEB, 09	JUNE,09
10	Completion of works	MAR, 09	JULY,09

##### 11.1.1 Contract Period

**The contract period shall be 14 months** from the start of work. Erection, testing, calibration and commissioning of permanent equipments required for completion of system shall be completed within the time schedule given above. Permanent erection of the first major sub-assembly/main assembly of any other equipment on its designated foundation/location following due process of pre-assembly and quality checks as per approved field quality plan (FQP) shall be considered as the start of contract period for this contract. Placement of packer plates etc shall not be considered as start of erection.

**BHEL, owing to its commitment to their customer, may ask contractor to compress the schedule to the possible extent for advancement of various milestones. Contractor shall plan his activities and mobilise additional**

**resources accordingly to the satisfaction of BHEL engineer within the quoted rates.**

#### **11.1.2 Grace period**

Grace Period of **3 months** will be allowed at BHEL's discretion.

#### **11.2**

The contractor should reach site and establish his site office and mobilise to commence the work as per directions of BHEL engineer. The date of starting the work at site shall be fixed in consultation with BHEL's engineer and the same will be recorded in measurement book while entering the first RA bill.

#### **11.3**

Subject to availability of materials and other inputs, it is the responsibility of the contractor to carry out work to achieve the monthly progress and keep up the schedules.

#### **11.4**

Contractor shall draw the monthly erection programme along with BHEL engineer indicating the work to be achieved and event to be completed as per clause 11.1. Once the programme is drawn, he shall adhere to the same. Contractor shall plan and erect the materials as it is received at site. The monthly planned percentage shall take into consideration the material available at site before the start of the month and also any material received during the month. Contractor shall mobilise his resources required to achieve the monthly programmes.

#### **11.5 Progress and monitoring of work**

##### **11.5.1**

It is the responsibility of the contractor to provide all the relevant information on a regular basis regarding erection progress, welding progress, labour availability, equipment deployment, consumption of electrodes, gases, down time of measuring test equipment etc.

##### **11.5.2**

The contractor shall submit daily, weekly and monthly progress reports, manpower reports, material reports, equipment reports etc. as per formats specified by BHEL. The progress reports shall indicate the progress achieved against planned with reasons indicating the delays, if any. The report shall also give the remedial actions that the contractor intends to make good the slippage or lost time so that further works can proceed as per the original programme and the slippage do not accumulate and affect the overall programme.

##### **11.5.3**

Any other information required for decision-making, planning and action taking, the contractor shall furnish the same, other reports and daily/weekly/monthly erection progress shall be furnished in the format prescribed by BHEL.

##### **11.5.4**

Contractor shall work out tentative programmes of erection, commissioning to match the schedules indicated in clause 11.1 and should submit along with his offer the month-wise calibration, erection and testing and commissioning programme area-wise.

#### **11.6.0 Quantity Variation**

##### **11.6.1**

***The quantities shown in rate schedule are only estimated and the payment will be made on the actual quantity executed on unit rate basis. Variation in quantities upto  $\pm 40\%$  in case of the cable and other items to be considered while quoting. Agreed rates shall remain firm for any upward and downward variation.***

#### **11.7.0 Price Variation**

##### **11.7.1**

The rates quoted by the contractor shall remain firm throughout the contract period, grace period and extensions if any. Provisions of clause no. 2.16 of General Conditions of Contract shall not be applicable to this contract.

#### **11.8.0 Extension of Contract Period**

##### **11.8.1**

BHEL at its discretion may extend the contract beyond the end of grace period for further required period depending upon the quantum of work left out at the end of grace period. If the completion of work gets delayed for reasons other than attributable to the contractor or force-majeure condition, the contractor will be compensated by way of Overrun Charges.

##### **11.8.2**

Overrun period beyond the grace period shall be decided based on the performance of contractor during the normal completion period and shortfall if any shall be recorded under the following heads:-

Erection/commissioning programme not achieved owing to non-availability of fronts.

Erection/commissioning programme not achieved owing to non-availability of materials.

Erection/commissioning programme not achieved owing to non-availability of tools and plants, manpower and consumables by the contractor.

### **11.8.3**

Total extension shall be apportioned between BHEL and contractor in the same proportion. Extension on account of delay attributable to contractor shall be exhaustive fist.

### **11.8.4**

During the over-run period, contractor shall deploy necessary and adequate resources like engineers, supervisors, labours, T&P and consumable to complete the agreed programme in each month.

### **11.8.5**

Over-run compensation will be paid proportionate to the progress made during the corresponding month evaluation of progress of the achievements vis-à-vis programme drawn for respective month, shortfall will be apportioned accordingly between BHEL and contractor.

### **11.8.6 Overrun Charges**

If the contract is extended beyond the contract (including grace) period for any reason other than those attributable to the contractor or force majeure conditions, the contractor will be compensated by payment of overrun charges at the rate of Rs. 50,000/- per month (Rupees fifty thousand only). Overrun compensation will be paid for the extension attributable to bhel only. No overrun compensation will be payable for the extension on account of reasons attributable to contractor and/or force majeure conditions. Overrun compensation for eligible period shall be in proportion to the progress achieved against the plan for respective period.

## **11.9 Foreclosing of Contract**

### **11.9.1**

BHEL, at its discretion may foreclose the contract at any time after the completion of contract period from the date of starting the work at site.

### **11.9.2**

In case it is decided to withdraw any portion of work or foreclose the contract, the percentage value of the work withdrawn / left over shall be determined mutually. BHEL engineer's decision in regard to status of an item shall be final and binding on the contractor.

### **11.9.3**

The date of completion of work for the purpose of guarantee vide clause 2.13 of general conditions will be the date on which the contract is foreclosed.

### **11.10**

Clause 2.12 of GCC regarding force majeure shall, inter-alia, include stoppage of work due to 'local bandhs' arising out of external factors.

## **11.11 INTEREST BEARING ADVANCE**

Interest bearing (rate of interest will be 1% per annum more than bank interest rate, on monthly reducing balance basis) recoverable advance limited to 5% of the contract value may be paid by BHEL at its discretion depending on the merit of the case against receipt & acceptance of bank guarantee from the contractor for the

amount sought. This bank guarantee (BG) shall be valid at least for one year or the recovery duration. In case recovery of dues does not get completed within the aforesaid BG validity period, the contractor must renew the validity of BG or submit fresh BG for the outstanding amount and remaining recovery period. BHEL is entitled to make recovery of the entire outstanding amount in case the contractor fails to comply with the BG requirement as above.

Recovery of dues will be made minimum @ 10% of the admitted gross running bill amount from the first applicable running bill onwards till entire due (principal plus interest) is recovered. In the event sufficient time duration is not left for recovery @10%, the rate of recovery shall be suitably enhanced so that entire due is recovered within the contract period (including extensions granted or foreclosure if any).

#### **11.12 DEFINITION OF WORK COMPLETION**

The contractor's scope of work under these specifications will be deemed to have been completed in all respect, only when all the activities are completed satisfactorily and so certified by BHEL site in charge. The decision of BHEL in this regard shall be final and binding on the contractor.

## SPECIAL CONDITIONS OF CONTRACT

### SECTION-12

#### 12.0 TERMS OF PAYMENT

##### 12.0.1

The contractor shall submit his monthly on account bills with all the details required by BHEL on specified date every month covering progress of work in all respects and areas from the 25<sup>th</sup> of previous calendar month to 24<sup>th</sup> of the current month.

##### 12.0.2

Clause 2.6 of general conditions of contract shall be referred to as regards mode of payment, and measurement of the work completed.

##### 12.0.3

Release of payment in each running bill will be restricted to 95% of the value of work admitted, as per the percentage break-up for the stage of work completion stipulated vide clauses hereinafter.

The 5% thus remaining shall be on account of workmanship guarantee of work executed. The same will be released after completion of the guarantee period of **12 months** from the date of completion of entire work as certified by BHEL.

However, on specific request of vendor, this amount may be released on pro rata basis for the value of work executed and accepted by BHEL, along with any RA Bill and onwards, subject to receipt and acceptance of bank guarantee of equal amount in BHEL's prescribed format. The BG shall be kept valid till completion of such guarantee period and an additional six months claim period. This is also subject to the condition that the contractor has started the work and also furnished/remitted the initial Security Deposit as per contract.

##### 12.0.4

The payment for running bills will normally be released within around 30 days of submission of running bill with measurement sheets. Contractor shall make his own arrangement for making payment of impending labour wages and other dues in the meanwhile.

##### 12.0.5

BHEL will release payment through Electronic Fund Transfer (EFT)/RTGS. In order to implement this system, the following details are to be furnished by the Contractor pertaining to his Bank Accounts where proceeds will be transferred through BHEL's banker:

1. Name of the Company
2. Name of Bank
3. Name of Bank Branch
4. City/Place
5. Account Number
6. Account type
7. IFSC code of the Bank Branch
8. MICR Code of the Bank Branch

BHEL may also choose to release payment by other alternative modes as suitable.

## 12.1 STAGES OF PROGRESSIVE PRO-RATA PAYMENTS

### 12.1.1

The agreed rates for each item shall be paid on pro-rata basis progressively as per the break up given hereunder (aggregating 100%), based on the progress of work in each month. The contractor shall submit his running bills with the details of measurement required by BHEL engineer on or before 26<sup>th</sup> of every month covering progress of work in all respect in the area upto 24<sup>th</sup> day of the same month.

### 12.1.2 Cables

1. 70% after laying of cable.
2. 10% after termination.
3. 10% after testing of cables.
4. 05% after dressing of cables
5. 03% after submission of as Built drg duly signed by Site engineer /customer.
6. 02 % completion of facilities and handing over.

### 12.1.3 Cable Tray

1. 80% after erection of trays in position
2. 15% after completion of welding/bolting.
3. 03 % after submission of as built drgs duly signed by Site engineer/ customer
4. 02% after completion of facilities and handing over.

## 12.2 PAYMENT FOR THE WORK COMPLETED

### 12.2.1

For the items where the payment is to be made against unit of weight, the actual weight of items erected by contractor will be paid after assessing the weight on the basis of shipping list or standard engineering practice. BHEL engineer's decision will be final and binding on contractor in this regard.

### 12.2.2

The bidder shall quote separate unit rates for each item of work listed in the rate schedule.

## 12.3 Measurement for Payment

### 12.3.1

In rate schedule, unit rates called for erection, testing and commissioning for various devices and equipment and payment shall be made accordingly.

### 12.3.2

For all payment purpose, measurement shall be made on the basis of physical measurement. Contractor shall make physical measurement in presence of BHEL engineer. Contractor shall maintain records for utilization of material system-wise.

### **12.3.3**

All the surplus, scrap and serviceable materials shall be returned by the contractor to BHEL's stores as per the instruction of engineer

**12.3.4** Wherever additional cabling work has to be carried out for performance guarantee test, the same has to be executed by the contractor as per the applicable rates already provided in the rate schedule.

For the items where the payment is to be made against unit of weight, the actual weight of items erected by contractor will be paid after assessing the weight on the basis of shipping list or standard engineering practice. BHEL engineer's decision will be final and binding on contractor in this regard.

### **12.3.6**

All the cables returned to stores should carry aluminium tag(s) indicating the size and type of cables. Cable of more than five-meter length is termed as "serviceable material".

### **12.3.7**

Any item returned to stores shall be clearly identified and tagged for its serviceability or any defects in the returned items.

## Section –13

### Special Conditions of Contract

#### 13.0 Extra Charges For Rectification And Modification

##### 13.1

If extra works (requiring less than **40 man-hours**) for modification, rework, revamping, in brief, any work done to change the state existing to a stage desired and also fabrication, all or any, are needed due to any change in or deviation from the drawings and design of equipment, operation/ maintenance requirements, mismatching, transit damages and other allied works which are not very specifically indicated in the drawings, but are found essential for satisfactory completion of the work, are done, no extra charges will be paid. The tenderers are requested to take this aspect into account and the quoted rate should include all such contingencies.

##### 13.2

It may also be noted that if any such said extra works arise on account of the contractor's fault it will have to be carried out by the contractor free of cost. Under such circumstances, any material and consumable required for this purpose will also have to be arranged by the contractor at his cost.

##### 13.3

However, BHEL may consider for payment as extra, for such of those works detailed in clause 13.1 which require more than **40 man-hours** and such payment will be regulated by the terms, conditions and stipulations contained in the clauses 13.4 to 13.8 and/or 14.2.1 to 14.2.10 as the case may be. It may be specifically noted that the decision of BHEL as to whether such payment is due shall be final and binding on the contractor. It may also be noted that only those works, which are identified as major and warrant extra payment and certified as such by the site engineer and accepted by the designers and/or competent authority of BHEL, will be considered for extra payment.

##### 13.4

For extra works arising out of transit, storage and erection damages, payment, if found due, will be regulated by clauses 14.2.1 to 14.2.10.

##### 13.5

All the extra work should be carried out by a separately identifiable gang, without affecting routine activities. Daily log sheets in the pro-forma prescribed by BHEL should be maintained and shall be signed by the contractor's representative and BHEL engineer. No claim for extra work will be considered/entertained in the absence of the said supporting documents ie. Daily log sheets. It may, however be noted that signing of log sheets by BHEL engineer does not mean the acceptance of such works as extra works. All admissible claims shall be submitted to BHEL

##### 13.6

BHEL retains the right to award or not to award any of the major repair/rework/modification/rectification/fabrication works under clauses 13.1 to 13.6 to the contractor, at their discretion without assigning any reason for the same.

13.7

Extra works that arise on account of contractor's fault will have to be carried out by the contractor free of cost including the supply of material and consumables

13.8

After eligibility of extra works is established and finally accepted by BHEL engineer/designer, payment will be released on competent authority's approval at the following rate.

**Man-day rate for eligible extra works :**

Single average man-day rate, including overtime if any, and other site expenses and incidentals, including consumables, tools and tackles, for carrying out rework / repairs / rectification / modification / fabrication for a man-day of 8 hours as may arise during the course of erection will be **Rs. 240/- (Rupees Two hundred and forty only)**

As mentioned above, no payment will be made if an item of work lasts less than 40 man-hours.

## **Section-14**

### **Special Conditions of Contract**

#### **14.0 Insurance**

##### **14.1 Marine, Storage cum Erection (MCE) Insurance and Repairing Damages**

BHEL/client has an MCE insurance cover, inter-alia, for all the permanent project equipments/components supplied by BHEL under scope of this work under a transit and storage cum erection policy covering liability against damages/ losses etc.

##### **14.2 Reporting Damages and Carrying Out Repairs**

###### **14.2.1**

Checking all components/equipments at siding/site and reporting to transporter and /or insurance authorities of any damages/losses will be done by BHEL.

###### **14.2.2**

Contractor shall render all help to BHEL in inspection including handling, re-stacking etc, assessing and preparing estimates for repairs of components damaged during transit, storage and erection, commissioning and preparing estimates for fabrication of materials lost/damaged during transit, storage and erection. Contractor shall help BHEL to furnish all the data required by railways, insurance company or their surveyors.

###### **14.2.3**

Contractor shall report to BHEL in writing any damages to equipments/ components on receipt, storing, and during drawl of the materials from stores, in transit to site and unloading at place of work and during erection and commissioning. The above report shall be as prescribed by BHEL site management. Any consequential loss arising out of non-compliance of this stipulation will be borne by contractor.

###### **14.2.4**

Contractor shall carry out fabrication of any material lost/damaged as per instructions from BHEL engineer.

###### **14.2.5**

BHEL, however, retains the right to award or not to award to the contractor any of the rectification/rework/repairs of damages and also fabrication of components.

###### **14.2.6**

All the repairs/rectification/rework of damages and fabrication of materials lost, if any, shall be carried out by a separately identifiable gang for certification of man-hours. Daily log sheets should be maintained for each work separately and should be signed by contractor's representative and BHEL engineer. Signing of log sheets does not necessarily mean the acceptance of these as extra works.

###### **14.2.7**

All rectification, repairs, reworks and fabrication of components lost, which are minor and incidental to erection work (consuming not more than 40 man-hours on each occasion) shall be treated as part of work without any extra cost.

#### 14.2.8

Insurance cover under this policy will generally be as per clauses 2.10.1 to 2.10.4 of General Conditions of Contract unless and otherwise specified differently in the Special Conditions.

#### 14.2.9

in case the loss/damage is not attributable to the contractor, Payments of all extra works on account of repair / rectification / reworks of damages and fabrication of materials lost will be as per provisions of Section-13.

#### 14.2.10

In case the repairs/rectification/rework and fabrication of materials lost, the work has been done by more than one agency including the contractor, the payment towards extra charges will be on pro-rata basis and the decision of BHEL in this regard is final and binding on the contractor.

#### 14.2.11

In case of theft / damage / loss of materials due to negligence or failure attributable to the contractor, the expenses incurred on account of repair/ replacement of such components including BHEL's overhead expenses as applicable (presently @ 30%) in excess of the amount realized from the underwriters shall be recovered from the contractor. Recovery will be limited to Normal Deductible Franchise (DF) / Excess as per applicable Insurance (TAC) tariff guidelines. However, in case such insurance claim is summarily rejected by the underwriters due to wilful damage/loss on the part of the contractor, the total cost of repair/ replacement shall be recovered from the contractor.

### **14.3 Insurance by the contractor and indemnification of BHEL**

BHEL have taken a third party liability insurance, indicating in the proposal for such insurance that sub-contractors will be taking part in the erection work detailed in this tender. However, the tenderer has to bear any expenses /consequences over and above the amount that may be reimbursed to BHEL by such coverage of third party liability insurance taken by BHEL.

Such additional liability will be to cover and indemnify BHEL and its customer of all liabilities which may come up and cause harm/damage to other contractors/ customer/BHEL properties/personnel or all or anybody rendering service to BHEL/customer or is connected with BHEL/customer's work in any manner whatsoever. The tenderer's specific attention is also invited to clause 2.10 of General conditions of contract.

Contractor shall obtain and operate suitable insurance policies to cover the risk pertaining to the assets/properties and personnel belonging to or deployed by him.

## SECTION-15

### Special Condition of Contract

#### 15.0 Earnest Money Deposit & Security Deposit

##### 15.1 EARNEST MONEY DEPOSIT:

EMD for this tender is Rs. 2,00,000/- (Rupees Two lakhs only). Bidders who have already deposited One Time EMD of Rs. 2.00 lakh will be exempted from submission of any EMD now for this tender.

EMD is to be paid in **cash** (as permissible under Income Tax Act), Pay order or **Demand Draft** in favour of Bharat Heavy Electricals Limited and payable at Nagpur.

**NO OTHER FORM OF EMD REMITTENCE SHALL BE ACCEPTABLE TO BHEL.**

15.1.1 EMD BY THE TENDERER WILL BE FORFEITED AS PER TENDER DOCUMENTS IF

- I) AFTER OPENING THE TENDER, THE TENDERER REVOKES HIS TENDER WITHIN THE VALIDITY PERIOD OR INCREASES HIS EARLIER QUOTED RATES.
- II) THE TENDERER DOES NOT COMMENCE THE WORK WITHIN THE PERIOD AS PER LOI / CONTRACT. IN CASE THE LOI / CONTRACT IS SILENT IN THIS REGARD THEN WITHIN 15 DAYS AFTER AWARD OF CONTRACT.

15.1.2 EMD SHALL NOT CARRY ANY INTEREST.

##### 15.2 SECURITY DEPOSIT

15.2.1 SECURITY DEPOSIT SHOULD BE COLLECTED FROM THE SUCCESSFUL TENDERER. THE RATE OF SECURITY DEPOSIT WILL BE AS BELOW:

SN	Contract Value	Security Deposit Amount
1	Up to Rs. 10 lakhs	10% of Contract Value
2	Above Rs. 10 lakhs upto Rs.50 lakhs	1 lakh + 7.5% of the Contract Value exceeding Rs. 10 lakhs.
3	Above Rs. 50 lakhs	Rs 4 lakhs + 5% of the Contract Value exceeding Rs. 50 lakhs.

**THE SECURITY DEPOSIT SHALL BE REMITTED BEFORE START OF THE WORK BY THE CONTRACTOR IN THE MANNER SPECIFIED AS FOLLOWS.**

15.2.2 SECURITY DEPOSIT MAY BE FURNISHED IN ANY ONE OF THE FOLLOWING FORMS

- I) CASH (AS PERMISSIBLE UNDER THE INCOME TAX ACT)
- II) PAY ORDER, DEMAND DRAFT IN FAVOUR OF BHEL.
- III) LOCAL CHEQUES OF SCHEDULED BANKS, SUBJECT TO REALIZATION.
- IV) SECURITIES AVAILABLE FROM POST OFFICES SUCH AS NATIONAL SAVINGS CERTIFICATES, KISAN VIKAS PATRAS ETC.

(CERTIFICATES SHOULD BE HELD IN THE NAME OF CONTRACTOR FURNISHING THE SECURITY AND DULY PLEDGED IN FAVOUR OF BHEL AND DISCHARGED ON THE BACK).

- V) BANK GUARANTEE FROM SCHEDULED BANKS / PUBLIC FINANCIAL INSTITUTIONS AS DEFINED IN THE COMPANIES ACT SUBJECT TO A **MAXIMUM OF 50%** OF THE TOTAL SECURITY DEPOSIT VALUE. THE BALANCE 50% HAS TO BE REMITTED EITHER BY CASH OR IN THE OTHER FORM OF SECURITY. THE BANK GUARANTEE FORMAT SHOULD HAVE THE APPROVAL OF BHEL.
- VI) FIXED DEPOSIT RECEIPT ISSUED BY SCHEDULED BANKS / PUBLIC FINANCIAL INSTITUTIONS AS DEFINED IN THE COMPANIES ACT. THE FDR SHOULD BE IN THE NAME OF THE CONTRACTOR, A/C BHEL, DULY DISCHARGED ON THE BACK.
- VII) SECURITY DEPOSIT CAN ALSO BE RECOVERED AT THE RATE OF 10% FROM THE RUNNING BILLS. HOWEVER IN SUCH CASES AT LEAST 50% OF THE SECURITY DEPOSIT SHOULD BE REMITTED (EITHER BY CASH/DD OR **BG FOR MAXIMUM 50%** OF TOTAL SD) BEFORE START OF THE WORK AND THE BALANCE 50% MAY BE RECOVERED FROM THE RUNNING BILLS.
- VIII) EMD OF THE SUCCESSFUL TENDERER, EXCEPTING THOSE WHO HAVE REMITTED ONE TIME EMD, SHALL BE CONVERTED AND ADJUSTED AGAINST THE SECURITY DEPOSIT OR SPECIFIC REQUEST BY THE CONTRACTOR.
- IX) THE SECURITY DEPOSIT SHALL NOT CARRY ANY INTEREST.

**NOTE:** ACCEPTANCE OF SECURITY DEPOSIT AGAINST SL. NO. (IV) AND (VI) ABOVE WILL BE SUBJECT TO HYPOTHECATION OR ENDORSEMENT ON THE DOCUMENTS IN FAVOUR OF BHEL. HOWEVER, BHEL WILL NOT BE LIABLE OR RESPONSIBLE IN ANY MANNER FOR THE COLLECTION OF INTEREST OR RENEWAL OF THE DOCUMENTS OR IN ANY OTHER MATTER CONNECTED THEREWITH.

15.2.3 SECURITY DEPOSIT SHALL NOT BE REFUNDED TO THE CONTRACTOR EXCEPT IN ACCORDANCE WITH THE TERMS OF THE CONTRACT.

## SECTION –16

### TECHNICAL DETAILS, BILL OF QUANTITIES & LIST OF DRAWINGS

#### GENERAL TECHNICAL REQUIREMENTS OF CABLING INSTALLATION SPECIFICATION NO. PES-507-11 REV 1

#### CONTENTS

- 1.0 GENERAL
- 2.0 CODES AND STANDARDS
- 3.0 DESIGN REQUIREMENTS
  - 3.1 ITEMS OF SUPPLY FOR CABLING INSTALLATION
  - 3.2 CABLING CONCEPTUAL DESIGN
  - 3.3 ERECTION OF CABLE TRAYS, SUPPORTS AND ACCESSORIES
  - 3.4 WELDING
  - 3.5 SURFACE TREATMENT
  - 3.6 TRANSPORTATION AND STORAGE OF CABLE DRUMS
  - 3.7 LAYING OF CABLES
  - 3.8 SUPPORT SPACING AND CLAMPING
  - 3.9 LAYING OF CABLES DIRECTLY BURIED IN GROUND
  - 3.10 CABLE TERMINATION AND JOINTING
  - 3.11 EARTHING OF CABLING SYSTEM
- 4.0 INSPECTION & TESTING
- 5.0 PRICES
- 6.0 MEASUREMENT & WASTAGES
- 7.0 ADDITIONAL POINTS OF CONSIDERATION
- 8.0 UNSPECIFIED WORK AND PAYMENT
- 9.0 PERFORMANCE GUARANTEE
- 10.0 DOCUMENTATION

## **16.1.0 GENERAL**

- 1.1 This specification covers the activities mentioned below, as applicable to various areas of power station:
- a) Installation of cable tray support system and respective cable tray accessories.
  - b) Laying and termination of cables.
  - c) Testing and charging of cables.
  - d) Supply and erection of miscellaneous items for completion of the cabling system.
  - e) All associated work for completion of cabling system.
  - f) Receipt of cables and cabling materials supplied by purchaser/others.
  - g) Site handling and storage of material.
  - h) Minor civil works.
- 1.2 The installation work shall generally be carried out as per purchaser's drawings and documents. As part of cable installation, the scope shall also include exact detailing / adaptation of the system to specific site needs, to Engineers approval.
- 1.3 The scope of supply of cabling materials as a part of cable installation work includes supply of all accessories including, but not limited to, cable clamps, clamping materials, ferrules, cable tags, nuts, bolts, and consumables like anti-corrosive paints, welding electrodes etc. required to complete the cabling system. All other sundry materials for minor civil work shall also be supplied by vendor.
- 1.4 The vendor's scope of cabling installation shall include cutting, bending, supporting, drilling, welding, clamping, bolting, painting etc., of the materials for providing a complete system for all the buildings and structures of the areas under the scope, as indicated in the drawings.
- 1.5 The scope under this specification also covers furnishing of all labour, material & equipment, site testing of the system and performance of all operations necessary for complete installation of cabling system.
- 1.6 Conduits, GI pipes etc. embedded in walls, roof slabs, floors, etc. will, in general, be furnished in place, wherever necessary, by the purchaser. However, in places where such facilities have not been provided the scope will include provision of such facilities as required as per approved drawings. This shall include all civil works like breaking walls, floors and refinishing walls, floors as may be required for fixing these pipes/conduits.
- 1.7 Vendor may be asked to carry out certain supply and/or erection works which are not specifically mentioned in the specification but are required to be done during project execution stage. Payment for such works shall be done as per laid-down criteria.
- 1.8 The vendor shall also be responsible for estimation of bill of quantities on the basis of the inputs provided by purchaser in the form of drawings etc., depending upon the

scope. Any shortfall or surplus in the estimated quantities shall be intimated to the purchaser periodically during project execution stages. Plan for reporting the estimated quantities shall be mutually agreed upon.

#### 1.9 WORKS EXCLUDED FROM VENDOR'S SCOPE

- a) Supply of cables.
- b) Supply of cable trays & accessories, structural steel, termination kits and straight through joints, cable glands, cable lugs, conduits, pipes, marshalling boxes. However, supply of these items shall be the scope of vendor if the same is covered under the scope in Section C and the technical requirements are covered in other specifications.
- c) Major civil works like excavation and concreting of concrete trenches, plate embedments on cable trenches, ceiling and floors.
- d) Civil works for ducting for crossing of roads & rail tracks.
- e) Conduits and pipes embedded in walls, floors etc.

#### **16.2.0 CODES AND STANDARDS**

2.1 Installation of cabling work shall comply with the latest edition of following Indian standards rules, regulations and acts. However, if Data Sheet A specifies conformance to any other international standard, equivalent BS / IEC / ISO / any other standard shall be applicable.

- a) IS:1255 Code of practice for installation and maintenance of power cables up to and including 33 kV rating.
- b) IS:732 Electrical wiring installation (system voltage not exceeding 650 V).
- c) IS:5216 Guide for safety procedures and practices in electrical works.
- d) IS:226 Structural steel (Standard Quality).
- e) IS:800 Code of practice for use of structural steel.
- f) IS:316 Code of practice for use of metal arc welding for general construction in mild steel.
- g) IS:1363 Hexagonal bolts, nuts and screws.
- h) IS:1572 Electroplated coatings of cadmium on iron and steel.
- i) IS:2629 Code of practice for hot dip galvanizing for iron and steel.
- j) IS:2633 Method of testing uniformity of coating on zinc coated articles.
- k) Indian Electricity Act.

- l) Indian Electricity Rules.
- m) Fire insurance regulations.
- n) Regulations laid down by the Chief Electrical Inspector of the State.
- o) Regulations laid down by the Factory Inspector of the State.
- p) Any other regulations laid down by the authorities.

2.2 In case any clause of contradictory nature arises between standards and this specification, the latter shall prevail.

### **16.3.0 DESIGN REQUIREMENTS**

#### **3.1 ITEMS OF SUPPLY FOR CABLING INSTALLATION WORK**

The supply of below listed items shall be considered to be part of cabling installation work for which no separate BOQ shall be given by the purchaser.

##### **3.1.1 Trefoil Cable Clamps**

- a) Clamps required for single core cables carrying alternating current shall be suitable for holding three cables together in delta formation.
- b) Clamps shall be of aluminium alloy or nylon material as per Data Sheet A.
- c) Design of clamps shall generally conform to the BHEL's drawing no. PE-4-999-507-003 enclosed with the tender.
- d) Clamps shall be of suitable sizes to firmly hold the cables of various outer diameters including the tolerance in OD.
- e) Purchaser may ask for conducting the Short Circuit Withstand Test on at least one size of clamp selected randomly. The requirement of the test, if required, is stipulated in Data Sheet A.
- f) Trefoil clamps shall be of BHEL approved make only.

##### **3.1.2 Omega Cable Clamps**

- a) Omega clamps shall be of aluminium alloy or mild steel and shall be used to fasten the individual multi-core cables.
- b) Clamps shall be of simple construction, made of 2mm thick, 25mm wide strip of omega shape and suitable for clamping on the rungs / perforated sheet of tray with the help of two bolts.
- c) Clamps shall be of different sizes for different outer diameters of cables. Omega cable clamps shall be used for individual cables above 35mm outer diameter.

d) Steel clamps shall be hot dip galvanized as per the requirements of Data Sheet A.

### 3.1.3 Strip Cable Clamps

- a) Strip clamps shall be of mild steel or aluminium and shall be used to fasten the group of multi-core cables up to 35mm diameter only on a full or part of the tray width.
- b) Clamps shall be of simple construction, made of 4mm thick (Al.) or 3mm thick (Steel), 25mm wide strip to cover the entire width up to 300mm wide tray and part of the tray for more than 300mm wide trays. Strip shall have two right angle bends at each end for fixing on to the rung/ perforated sheet of tray with the help of two bolts.
- c) Clamps shall be of different sizes for different sizes of tray width. However, the maximum size of clamp shall be 300mm and for cable trays of greater width, two clamps shall be used.
- d) Clamps shall be hot dip galvanized.

### 3.1.4 Self Locking Clamps

- a) Clamps shall be of nylon material.
- b) Clamps shall have self locking feature when the cord is looped.
- c) Clamps shall be provided with manual lock release.
- d) Clamp cord shall not move in the backward position once it has been locked, unless the lock release is applied.
- e) Type test certificates to ascertain the strength of clamps shall be submitted for purchaser's approval.
- f) Not more than four (4) cables shall be clamped together, wherever collective clamping is permitted.
- g) Clamp length shall be selected such that not more than 80% of lockable length is utilised for clamping.
- h) Sizes and other parameters of clamps shall be as per Data Sheet A.
- i) Self locking clamps shall be of BHEL approved make only.

### 3.1.5 Ferrules

- a) Ferrules shall be required for individual core of control cables, hence they shall be suitable for the insulated conductor diameter.
- b) Ferrules shall be of plastic material.

- c) Numbering on the ferrules shall be engraved type with contrast colour to the base. Colour of ferrule and engraving shall be as per Data Sheet A. Engrave colouring shall be of durable quality to match the entire life of the plant.
- d) Engraving shall be legible from a distance of 600mm.
- e) Ferrules shall be interlocked type such that the interlocked ferrules take the shape of tube with complete ferrule number arranged in a straight line.

#### 3.1.6 Tags

- a) Cables shall be provided with cable number tags for identification.
- b) Cable tags shall be of durable fiber, aluminium or stainless steel sheets as per Data Sheet A.
- c) Cable numbers shall be engraved type in case of aluminium or stainless steel tags, and printed type in case of fiber sheet.
- d) Tags shall be of durable quality of size 60mm x 12mm with a tie hole at each end.
- e) Samples of tags shall be approved by the purchaser before delivery.
- f) Tags shall be provided with non-corrosive wire of sufficient strength for tagging.

#### 3.1.7 Miscellaneous items

Items required for the buried cables such as cable markers, bricks, sand, protective slabs etc. shall be to the approval of purchaser.

### 16. 3.2 CABLING CONCEPTUAL DESIGN

- 3.2.1 In the plant building, substations, switchgear rooms, control rooms etc., power and control cables shall generally be laid on cable trays installed in concrete trenches, tunnels, cable basements, cable vaults, cable shafts or along building and technological structures as the case may be.
- 3.2.2 In case of multicore cables of diameter up to 30 mm where not more than 3 cables are taken in one run, these can be taken directly along structures, walkways, platforms, galleries, walls, ceiling etc. by proper clamping at regular intervals of 750 mm or less.
- 3.2.3 Power & control cables installed along buildings, structures, ceilings, walls, etc., which are required to be protected against mechanical damage, shall be taken in GI conduits.
- 3.2.4 GI Conduits shall also be used for flameproof installations, wherever required, with sealing at both ends.
- 3.2.5 Entry of cables from trenches/tunnels into buildings shall be by means of one of the methods indicated in drg no PE-4-999-507-002 as applicable for different buildings.

- 3.2.6 Cables laid exposed in racks/trays and routed from trenches/tunnels/basements etc to individual drive/ control devices etc shall be taken in embedded/exposed/surface-grouted rigid GI conduits and / or flexible conduits unless directly terminated to the equipment in the panels located above trenches, tunnels or basement.
- 3.2.7 All cables routed along walls or in equipment rooms shall be protected by means of laying them through G.I. pipes or by providing sheet metal covers up to a height of 2000 mm from the working floor levels and platforms, for protection against mechanical damage. All vertical risers shall be enclosed type.
- 3.2.8 Tray covers shall not be provided for the cable trays within trenches, tunnels, and basements. Non-perforated type sheet steel covers shall be provided for the trays in the areas susceptible to accumulation of coal dust / atmospheric abuses etc.
- 3.2.9 Cable trays shall be supported on ISA 50x50x6mm MS/GI brackets. Brackets shall be welded to steel plate inserts in the trenches/tunnels or supporting channel angle/inserts in other areas.
- 3.2.10 Where direct heat radiation from equipment/pipes exists, heat isolating barriers for cabling system shall be adopted. System shall be to the approval of purchaser.
- 3.2.11 For 415 V power wiring in ancillary buildings, offices and laboratories, cables shall be taken through embedded/exposed GI conduits or rigid PVC pipes as applicable.
- 3.2.12 If required, in exceptional cases, a few number of cables may be directly buried into the earth.
- 3.2.13 wherever cables are to be laid below roads and railway tracks, the same shall be taken through ducts buried at a suitable depth.
- 3.2.14 At certain places where hazardous fumes/gases may cause fire to the cables, cable trenches after installation of cables may be sand-filled.
- 3.2.15 In corrosive atmosphere, PVC conduits shall be used for cables.
- 3.2.16 Single core cables, when pulled individually, shall be taken through PVC pipes only.
- 3.2.17 Cable routes shall be segregated unit wise, to the extent possible. Similarly, cables for the standby drives shall preferably be taken through the alternative route. Separate routes shall also be preferred for duplicate control supply cables, first and second channel protection cables, and cables to common station service of two or more units.
- 3.2.18 Cables shall be avoided below oil pipes and in the vicinity of steam pipes.
- 3.2.19 Cable trays may be laid in vertical formation in boiler, mill and ESP areas to avoid accumulation of coal-dust / ash on cables and cable-trays. Alternatively, cable trays may be laid in horizontal formation with GI covers on each tray.

### 16.3.3 ERECTION OF CABLE TRAYS, SUPPORTS AND ACCESSORIES

- 3.3.1 Cable tray/racks, tray fittings, (such as elbows, reducers, tees etc.) & tray support structure shall be erected by the vendor.

- 3.3.2 Constructional details and supporting arrangement for the cable trays shall be as shown in the drawings which will be handed over to the successful bidder. All cable trays, vertical raceways and supporting steel work shall be installed along the routes as indicated in the drawings and as per the instructions of the Engineer.
- 3.3.3 Wherever specified or directed by Engineer, the vendor shall install galvanized MS sheet covers over cable trays. The width of the covers shall be same as that of cable trays. Bolting shall be done to fasten covers to the cable trays, elbows, reducers, tees, crosses etc.
- 3.3.4 The vendor shall install all angles, channels, beams, hangers, brackets, clamps etc. as may be necessary to suit the actual site conditions to support the cable trays.
- 3.3.5 Straight pieces of standard MS angles/channels shall be used for fabrication of supports/racks. All welded joints shall be smooth enough to provide a good appearance and shall not cause injury to working personnel.
- 3.3.6 Cable trays within cable trenches, tunnels and basements shall be of ladder type. Bottom most tray within plant buildings for overhead runs of trays shall be of perforated type. Cable trays in the areas exposed to coal dust shall be installed in vertical formation. Wherever, due to layout constraints, it is not possible to install the trays in vertical formation, laying of trays in horizontal formation may be considered with Engineer's prior permission.
- 3.3.7 Cable trays/racks shall be so arranged that they do not obstruct or impair clearances of passage way, maintenance of adjacent equipment, if any.
- 3.3.8 For installation of cables in GI conduits, complete conduiting system shall be installed first without cables but having suitable pull wires laid in conduits.
- 3.3.9 For equipment and devices having GI conduit entry arrangement other than standard GI conduit adopter, transition adopters shall be provided as required to enable the GI conduit to be properly terminated, between conduit end and motor terminal block.
- 3.3.10 GI conduits shall run without moisture or water traps and shall be arranged to drain towards the ends.
- 3.3.11 The entire GI conduit system shall be firmly fastened in position. All boxes and fittings shall generally be secured independently from the GI pipes entering them.
- 3.3.12 Bends of GI pipes/conduits shall be made without causing damage to the pipes/conduits.
- 3.3.13 Occupancy of conduits shall not be greater than 40%.
- 3.3.14 The adopter for coupling rigid GI pipe/ conduit and flexible conduit shall be of aluminium or galvanized steel.

#### 16.3.4 WELDING

- 3.4.1 All welded connections shall be made by electric arc welding. All welding work shall be carried out by qualified and experienced welders.

- 3.4.2 All arc welding shall be carried out with low hydrogen content electrode.
- 3.4.3 All welded joints shall be allowed to cool down gradually to atmospheric temperature before putting any load on them. No artificial cooling should be adopted to cool welded joints.
- 3.4.4 The welding shall have adequate strength.
- 3.4.5 Before welding, the conductors shall be clamped tightly to ensure good surface contact at welding points.

#### 16.3.5 SURFACE TREATMENT

Surface treatment of all materials supplied/ erected shall be done in an approved manner and as per the specific requirements given in the Data Sheet A. The materials supplied by the purchaser may be fully treated or partially treated. In case of partially treated items the remaining surface treatment shall be given to the materials after erection.

- 3.5.1 UNTREATED STEEL MATERIALS shall be given the following surface treatment
  - a) Surface cleaning : In the first step complete surface shall be cleaned with sand paper and/or cotton cloth to remove accumulated dust, dirt and rust.
  - b) Pretreatment : Pretreatment shall conform to the requirements of IS:6005. The clean and dry pretreated surface shall be given a coat of red oxide primer paint and shall be left for natural drying.
  - c) Surface finish : Two coats of abrasion resistant synthetic enamel of desired colour shall be applied on the pretreated surface with sufficient time interval for drying up. Surface finish after the painting shall be smooth, uniform and free from spots.
- 3.5.2 PARTIALLY TREATED materials which are supplied with a single coating of primer paint shall be given the following treatment :

Two coats of abrasion resistant synthetic enamel of desired colour shall be applied on the pretreated surface with sufficient time interval for drying up. Surface finish after the painting shall be smooth, uniform and free from spots.
- 3.5.3 GALVANIZED ITEMS shall be given a surface treatment only at the welded joints and at the places where the galvanization has been damaged. Welded joints shall be applied with two coats of cold zinc paint whereas damaged portions of galvanizing shall be applied with single coat of zinc paint.
- 3.5.4 In addition to the above, the vendor shall ensure after completion of cable erection work that the final finish of all surfaces of trays and support materials is in good condition and wherever needed a touch up of enamel/ cold zinc paint, as applicable, shall be given.
- 3.5.5 The final finish of all erected materials shall be uniform, clean, smooth and free from spots.

### 16.3.6 TRANSPORTATION & STORAGE OF CABLE DRUMS

- 3.6.1 Transportation and storage of cable drums shall generally conform to the requirements of IS:1255. BHEL approved Field Quality Plan shall also be adhered to.
- 3.6.2 All the cables shall be supplied to vendor free of cost from purchaser's store/storage area. Transportation of cables from purchaser's storage area to the work site shall be the responsibility of vendor.
- 3.6.3 The cable drums shall be transported on wheels to the place of work.
- 3.6.4 Empty cable drums shall be the property of purchaser.

### 16.3.7 LAYING OF CABLES

- 3.7.1 Laying and installation of power, control and special cables shall generally conform to IS:1255.
- 3.7.2 The cables shall be paid-out in proper direction from the cable drums (opposite to the normal direction of rotation for transportation).
- 3.7.3 In case of higher size cables, the paid out cables shall run over rollers placed at close intervals and finally transferred carefully on the racks/trays. Care shall be taken so that kinks and twists or any mechanical damage does not occur to cables. Only approved cable pulling grips or other devices shall be used. Under no circumstances cables shall be dragged on ground or along structure while paying out from cable drums, carrying to site and straightening for laying purpose.
- 3.7.4 All possible care shall be given while handling un-armoured cables.
- 3.7.5 Suitable extra length of cables shall be provided for all feeders for any future contingency. Additional lengths shall be as under :
  - a) Power cables : one loop with permissible bending radius.
  - b) Control cables : 1 - 1.5 metre
- 3.7.6 Cable runs shall be uniformly spaced, properly supported and protected in an approved manner. All bends in runs shall be well defined and made with due consideration to avoid sharp bending and kinking of cable. The bending radius of various types of cables shall not be less than those specified by cable manufacturers and that specified in IS:1255.
- 3.7.7 All cables shall be provided with identification tags indicating the cable numbers in accordance with the cable circuit schedule. Tags shall be fixed at both ends of cables, at each bend, and both sides of floor/wall crossings.
- 3.7.8 When a cable passes through a wall, cable number tags shall be fixed on both sides of the wall.
- 3.7.9 Single core cables for a. c. circuits shall form a complete circuit in trefoil formation supported by means of trefoil clamps of nonmagnetic material.

- 3.7.10 Multi-core cables above 1100 V grade shall be generally laid in ladder type trays in one layer with spacings not less than one cable diameter of bigger diameter cable.
- 3.7.11 All 1100 V grade multicore power cables and single core DC cables shall be placed in single layer, touching each other and clamped by means of single or multiple galvanized MS saddles/ aluminium strips/ nylon cable ties as specified in Data Sheet A or as agreed for the contract. Cables above 35mm outer diameter shall be clamped individually.
- 3.7.12 Control cables shall be laid touching each other and may not preferably be taken in more than two layers.
- 3.7.13 Segregation of the cables on the basis of their types and their functions shall be as under for horizontal formations :
- a) HT cables shall be laid in the top tier(s).
  - b) LT power cables to be laid in the tray(s) below the HT cable trays.
  - c) LT control cables to be laid in the tray(s) next below to the LT power Cable tray(s).
  - d) Special control cables including screened control cables to be laid in the bottom most tray(s).
- 3.7.14 For vertical formations, the tray closest to the wall shall be considered as bottom most tray and the order indicated in clause just above shall be followed. However where there is no clear distinction of bottom/ top trays, the order convenient for linking the horizontal and vertical formations shall be followed.
- 3.7.15 When it may not be possible to accommodate cables as per the criteria indicated in the clauses 3.7.12 & 3.7.13 above, the following rules shall override the criteria. However prior approval of the Engineer will be required.

In hierarchical order :

- a) Control cables are mixed up with the special control cables with clear minimum gap of 100mm between them.
- b) LT power cables are mixed up with control cables with clear minimum gap of 150mm between them.
- c) LT power cables are mixed up with HT power cables with clear minimum gap of 200mm between them.

However, under no circumstances HT power cables can be mixed up with control cables of any type.

- 3.7.16 The vendor shall bring it to the notice of Engineer if the routes indicated in the cable schedules supplied by the purchaser defy the criteria indicated in above clauses for general arrangement of various types of cables in different trays.

- 3.7.17 In case of duplicate feeders to essential loads, the respective cables shall be laid through separate raceways. Alternatively, such cables shall be laid on the opposite sides of a trench/tunnel/basement.
- 3.7.18 For laying cables along building steel structures and technological structures, the cables shall be taken by clamping with MS saddles screwed to the MS flats welded to the structure. MS saddles and flats shall be galvanized.
- 3.7.19 For laying cables along concrete walls, ceilings etc., the cables shall be taken by clamping with MS saddles screwed to the MS flats welded on the inserts. Where inserts are not available the saddles shall be directly fixed to the walls using rawl plugs and MS flat spacers of minimum 6mm thickness.
- 3.7.20 To facilitate pulling of cables in GI conduits, powdered soft stone, plastic soap or other dry inert lubricant may be used but grease or other material harmful to the cable sheaths shall not be used.
- 3.7.21 No single core cable shall pass through a GI conduit or duct singly except DC single core cables. AC single core cables shall pass through GI conduits/pipes in trefoil formation only.
- 3.7.22 In case of 3-phase, 4 wire system, more than one single phase circuit, unless originating from the same phase shall not be taken in the same GI conduit.
- 3.7.23 Entry of cables from underground trenches to the buildings or tunnels shall be by some approved method. Necessary precautions shall be taken to make the entry point fully water tight by properly sealing the pipe sleeves wherever they enter directly into the building at trench level. The sealing shall be by cold setting compound. Any alternative sealing arrangement may be suggested with the offer for purchaser's consideration.
- 3.7.24 Wherever specific cable routes are not shown in cable schedules cables shall be laid as directed by Engineer.

#### 16.3.8 SUPPORT SPACING & CLAMPING

Support spacing and clamping shall be as per Data Sheet A

#### 16.3.9 LAYING OF CABLES DIRECTLY BURIED IN GROUND

- 3.9.1 Laying and installation of directly buried cables in ground shall conform to the requirements of IS:1255.
- 3.9.2 The part of the cable which is not buried shall comply with the requirements of clause 3.7 above, as applicable.
- 3.9.3 The desired minimum depth of laying from ground surface to the top of cable shall be as per Data Sheet A.
- 3.9.4 Bidder shall submit drawing indicating the proposed arrangement for buried cables. Drawing shall include the details of type of sand, protective covers and the overall arrangement.

### 16.3.10 CABLE TERMINATION AND JOINTING

- 3.10.1 Vendor shall carry out cable terminations at various electrical and electronic equipment terminals.
- 3.10.2 When the equipment are provided with undrilled gland plates for cable/conduit entry into the equipment, the vendor shall perform all drilling & cutting on the gland plate and any minor modification work required to complete the job at no extra cost to the purchaser. The vendor shall prepare a drawing showing the holes for cable entry in the gland plate and take Engineer's approval before drilling holes. Gas cutting shall not be allowed.
- 3.10.3 Termination of cables shall be done as per termination drawings & interconnection diagrams furnished to the vendor. Looping of cores/ wires at terminals and, if required, between the panels is to be done by the vendor at no extra cost.
- 3.10.4 All cable entries in the equipment shall be sealed by cable glands / or as per site engineer's instructions. The supply sealing materials like plugs etc shall be part of scope at no extra cost to the purchaser.
- 3.10.5 Adequate length of cables shall be pulled inside the switchboards, control panels, terminal boxes etc so as to permit neat termination of each core/conductor.
- 3.10.6 Power cable terminations shall be carried out in a manner such as to avoid strain on the terminals by providing suitable clamps near the terminals.
- 3.10.7 Control cable cores entering switchboard or control panels shall be neatly bunched and strapped with PVC perforated tapes/nylon ties and suitably supported to keep them in position at the terminal block. All spare cores shall be connected to spare terminals wherever possible. If spare terminals are not available, spare cores shall be neatly dressed and suitably taped at both ends.
- 3.10.8 Screened control cables of small cross sectional area, e.g. 0.5 sq mm, shall be terminated by means of Maxi-termi termination system. Vendor shall ensure the availability of all tools, tackles and accessories such as Maxi-termi guns, clips, wire etc. required for the termination of small cross section screened control cables by this method. Compressed air supply for Maxi-termi guns shall also be the responsibility of vendor.
- 3.10.9 Individual cores of control cables shall have ferrules for identification. Ferrule numbers shall be provided as per the control schemes and other related documents supplied by the purchaser.
- 3.10.10 End sealing/termination of HT cables shall be done by means specified in the specification for terminations. The system shall be suitable for types of cables specified and complete with stress relief system.
- 3.10.11 Termination and jointing of aluminium/ copper conductor power cables shall be done by means of compression method using compression type aluminium/ tinned copper lugs as indicated in Data sheet A.

3.10.12 Copper conductor control cables shall be terminated directly into screwed type terminals provided in the equipment. Wherever control cables are to be terminated by means of terminal lugs, the same shall be of tinned copper compression type.

3.10.13 Cable joint, not more than one in a circuit, shall normally be made at an intermediate point in the straight run of the cable only when the length of the run is more than the standard drum length supplied by the cable manufacturer. In such cases, when jointing is unavoidable, the same shall be made by means of specified cable-jointing kit, subject to purchaser's approval. Prior approval of Engineer shall be taken for deciding location of joint.

3.10.14 Junction boxes shall be used, wherever required, for jointing of control cables.

3.10.15 Termination and jointing shall generally conform to the requirements of IS:1255 and shall strictly conform to the recommendations of termination and jointing kit supplier.

### 16.3.11 EARTHING OF CABLING SYSTEM

3.11.1 Scope of earthing of support system shall be as per Data Sheet A. Scope, if included, shall be applicable for cable tray support structures, cable trays, conduits and pipes. All the conduits, trays and support structure on which the cables have been installed shall be bonded to the main earthing system. All the support arrangement shall be tested for electrical continuity and permanent connection to earth. Gas/water or other pipes shall not be used as earth medium.

3.11.2 Armour earthing :

- a) Armour of the HT cables and LT single core cables shall be earthed only at one end of cable.
- b) Armour of other cables shall be earthed at both ends of cable.

3.11.3 Screen Earthing:

- a) Screen of HT power cables shall be earthed at one end only.
- b) Screen of C&I screened control cables shall be earthed at one end.
- c) Screen of electronic earthing system cables shall be earthed as per the requirements to be furnished to the vendor during contract stage.

## **16.4.0 INSPECTION & TESTING**

### 4.1 INSPECTION

4.1.1 The following stages of fabrication/manufacture shall be stage inspected by the Purchaser or Engineer at site.

- a) Inspection of raw materials including hardware items such as bolts, nuts etc.
- b) Inspection of storage and material handling.

- c) Inspection of fabrication processes such as shearing, punching, bending, welding, galvanizing, painting etc.
  - d) Inspection at intermediate stages of erection.
  - e) Final inspection after erection.
- 4.1.2 The actual inspection shall be carried out as per the approved Quality Plan. Purchaser's standard Quality Plan is enclosed in Section-C of this specification.
- 4.1.3 All erection, fabrication, installation, testing & commissioning work shall be inspected in line with the requirements of IS:1255 and the approved Field Quality Plan.

#### 16.4.2 TESTING

- 4.2.1 The vendor shall take full responsibility of testing at erection, pre-commissioning and commissioning stages of the cabling system being installed by him under the overall supervision of the Engineer. It shall be the overall responsibility of the vendor to arrange and complete all activities in complete coordination with equipment commissioning agency keeping in view the overall commissioning programme. The vendor shall submit to the Engineer a checklist for testing and commissioning and the activities shall be carried out in accordance with the check list.
- 4.2.2 Testing and electrical measurement of cable installations shall conform to IS:1255.
- 4.2.3 Prior to installation, cables shall be tested for
- a) Continuity of conductors.
  - b) Insulation resistance between conductors & earth.
  - c) Insulation resistance between conductors.
- 4.2.4 After installation cables shall be tested for
- a) Insulation resistance between conductors.
  - b) Insulation resistance between conductors & earth.
  - c) Conductor resistance (dc).
  - d) Capacitance between conductors (for cables above 11 KV grade).
  - e) Capacitance between conductor & earth ( —do— ).
  - f) DC High voltage test (for all HT cables & LT power cables of sizes 300 sq. mm and above).
  - g) Absence of cross phasing.
  - h) Firmness of terminations.

- 4.2.5 The checks and commissioning tests shall be carried out as part of the installation work and the vendor shall not be paid any extra amount for same.
- 4.2.6 The Owner may ask for such additional tests at site as in his opinion are necessary to determine that the works comply with the specification, manufacturer's instruction or the applicable IS code of installation. The vendor shall be responsible for conducting the tests and shall bear the cost of such additional tests.
- 4.2.7 The vendor shall perform all tests necessary to ensure that materials supplied and workmanship conform to the relevant standards and that such tests are adequate to demonstrate that the equipment will comply with the requirements of this specification.
- 4.2.8 The vendor shall have to bring all testing equipment & instruments in sufficient numbers to carry out the job simultaneously in more than one area. All instruments shall be calibrated to the satisfaction of the Engineer before actual testing and tests shall be conducted by qualified & experienced personnel.
- 4.2.9 All documents/records regarding test data and all other measured values shall be submitted to Engineer for approval and subsequent record and reference. All cables shall be energised only after certification from commissioning personnel. The results of all tests shall conform to the specification requirements as well as any specific performance data guaranteed during finalisation of contract.

#### **16.5.0 PRICES**

Unit prices listed out in this clause shall be applicable for payment to the vendor for activities covered under this specification. The following shall be kept in consideration while quoting the prices :

- a) Unit price of supply shall include design, manufacture, testing at works, packing, supply, transportation to site, handling and storage at site.
- b) Unit price of installation shall include transportation of materials from Vendor's/Owner's storage yard to work site, handling, testing before erection, testing after erection and commissioning of materials including supply and installation of all associated materials and consumables, carrying out of all associated minor civil works and furnishing of all skilled /unskilled labour, supervisory and commissioning staff.
- c) Wherever materials are supplied by the purchaser e.g. lugs, glands as part of equipment supply, vendor shall in no case make any claim for the supply of these materials.
- d) The unit prices quoted shall be for supply and/or installation as explained in detail in the clauses in subsequent paragraphs. No other prices shall be applicable for the purpose of payment.
- e) **While quoting the prices the supply and installation of following shall be considered as part of job:**
  - i. **Nylon ties for cable clamping, other types of clamps, Trefoil clamps for single core cables, PVC straps, aluminium strips,**

BHARAT HEAVY ELECTRICALS LIMITED : PSWR : NAGPUR  
TENDER SPECIFICATION No. BHE/PW/PUR/SLT-CBL/538

**MS saddles, interlocking type ferrules, aluminium/stainless steel tags as per the project requirements.**

- ii. **Fasteners like nuts, bolts, washers, spring washers, rawl plugs, anchoring bolts and lugs etc.**
  - iii. **Conduit plugs, gaskets, couplers, and insulated bushings.**
  - iv. **Sealing materials for wall and floor openings.**
  - v. **Consumables like enamels, cold zinc paint, electrodes for welding etc.**
  - vi. **Materials for minor civil works.**
- f) The following shall be arranged by the vendor at no extra cost :
- i. All unskilled and skilled labour.
  - ii. All supervisory and commissioning staff.
  - iii. All facilities/equipment for site fabrication such as cutting, bending and drilling equipment.
  - iv. Welding sets.
  - v. Material handling equipment.
  - vi. All special tools and tackles for erection.
  - vii. All testing equipment.
- g) Requirement of Quality Plan and Field Quality Plan shall be considered in the quoted prices.

5.1 Unit rate of INSTALLATION OF CABLE TRAY SUPPORT MATERIAL shall be applicable for the no. of pieces installed under the following categories :

- a) ISA 50x50x6 upto 1000mm length welded at one end.
- b) ISA 50x50x6 upto 1500mm length welded at intermediate point with a channel/beam.
- c) ISMC 100 upto 1500 mm length, welded at one end.
- d) ISMC 100 upto 1500 mm length, welded at two ends.
- e) ISMC 150 upto 1500 mm length, welded at one end.
- f) ISMC 150 upto 3000 mm length, welded at two ends.
- g) ISMB 150 upto 3000 mm length, welded at two ends.

- 5.2 Unit rates of INSTALLATION OF CABLE TRAYS & ACCESSORIES shall be applicable for the lengths installed and measured at the centre line of trays and accessories. Unit rates of installation shall be uniform for trays and accessories of the same width.
- 5.3 Unit rate of INSTALLATION OF CONDUITS AND PIPES (ALL TYPES) shall be applicable for the length of the various sizes of conduits installed as below :
- a) upto 25mm
  - b) above 25mm upto 50mm
  - c) above 50mm upto 75mm
  - d) above 75mm upto 100mm
- 5.4 Unit rate of INSTALLATION OF TRAY COVERS shall be applicable for the lengths installed and measured at the centre line of trays and accessories of various sizes.
- 5.5 Unit rate of CABLE LAYING shall be applicable for cable lengths actually installed. Unit rates shall include laying/pulling of cables in horizontal/vertical runs in trays, ducts, conduits; supply and erection of clamps, cable tags and markers etc.
- 5.6 Unit rate of CABLE TERMINATIONS shall be applicable for the no. of terminations installed for various sizes of cables. Unit rates shall include drilling of gland plates , fixing of glands, ferrules and lugs and connection to the equipment. Each cable end shall be treated as separate termination.
- 5.7 Unit rate of LAYING OF CABLES DIRECTLY BURIED IN GROUND shall be applicable for lengths of cables laid and shall be measured between the two points of cables entering into the ground. Following shall be the break-up of prices for directly buried cables :
- a) Unit rate of laying shall be same as that for the cables of same size laid in cable tray.
  - b) Unit rate of earth work in excavation and back-filling shall be quoted separately for the buried cables. earth work shall be measured in cubic metre of earth specifically excavated for the purpose of buried cables.
  - c) Unit rate of supply and filling of sand shall be applicable for the quantity of sand in cubic metres.
  - d) Unit rate of supply and erection of protective covering shall be applicable for the area of protective covering and shall be measured in terms of per square metre of protective cover.
- 5.8 Unit rate of ERECTION OF MARSHALLING BOX shall be applicable for no. of boxes actually installed in various locations. Price shall include supply of supporting material and fabrication of support work. Price of cable termination shall be exclusive of this price.

- 5.9 Unit rate of SUPPLY AND ERECTION OF STEEL INSERT PLATES shall be applicable for the no. of such plates provided in various locations. Price shall include all associated steel work such as minor chippings and provision of fasteners/anchor bolts etc.
- 5.10 Unit rate of INSTALLATION OF MS PROTECTIVE SHEETING shall be applicable for the sheeting provided in various locations. Price shall include cutting and fabrication of sheet and all associated work such as providing fasteners/anchor bolts etc. Sheeting shall be measured in square metre of sheet actually installed.
- 5.11 Unit rate of SAND FILLING OF TRENCHES shall be applicable for supply and filling of trenches with sand wherever applicable and shall be measured in terms of the trench volume in cubic metres. Trench volume shall be measured as if there were no trays and cables. However unit price shall include sealing of the filled up trenches by provision of brick walls and sealants within the trench in an approved manner.
- 5.12 Unit rate of SUPPLY OF GALVANIZED STEEL MATERIALS shall be applicable for the weight of steel material measured in tonnes. These materials shall include short fall quantities of channels/ angles/ beams etc. which are generally the scope of other specification.

#### **16.6.0 MEASUREMENT & WASTAGES**

- 6.1 QUANTITY MEASUREMENT AND RETURN OF SURPLUS QUANTITY
- 6.1.1 For all payment purposes, measurement shall be made on the basis of the execution drawings/physical measurements. Physical measurements shall be made by the vendor in the presence of the Engineer.
- 6.1.2 The measurements for cable laying shall be made on the basis of length actually laid from lug to lug including that of loops provided and paid accordingly.
- 6.1.3 All the surplus, scrap & serviceable cables cut out of the cables quantity i.e. issued by the Owner to the vendor shall be returned by the vendor to the Owner's stores/yard in good condition and as directed by the Engineer.
- 6.1.4 All cables being returned to stores should carry an aluminium tag indicating the size and type of cable. Cable of less than 5m length will be termed as scrap. Cable of length 5m and above shall be termed as serviceable material and shall be returned size wise and category wise to the owner's stores/yard.
- 6.1.5 Cable of serviceable lengths being returned to the stores in drums shall have their free ends sealed and the balance lengths on the drum (s) shall be noted and certified by the Engineer. This shall be applicable only for the purpose of accounting the cables issued by the Owner for installation.
- 6.1.6 While carrying out material appropriation with vendor, all the above points will be taken into account. All serviceable material returned by the vendor shall be deducted from the quantities issued for the respective sizes and categories and the balance quantity (ies) will be taken as the net quantity (ies) issued to the vendor. Material appropriation shall then be done and allowable scrap quantity calculated as per wastage allowance percentage specified above.

6.1.7 Any scrap/wastages generated by the vendor in excess of the allowable percentage shall be charged at the rates decided by the Engineer whose decision shall be final and binding on the vendor.

6.1.8 For steel material supplied by vendor all scrap shall be returned to purchaser's stores with due accounting.

#### 16.6.2 CUTTING & WASTAGE ALLOWANCE

6.2.1 Vendor shall carefully plan the cutting schedule of each cable drum in consultation with Engineer such that wastages are minimised and any resultant short lengths can be used where appropriate route lengths are available.

6.2.2 The wastage allowances as permissible for various items are indicated in Data Sheet A.

6.2.3 Cutting and wastage allowance shall be computed on the lengths of cables and weight of steel actually used, measured and accepted.

#### **16.7.0 ADDITIONAL POINTS OF CONSIDERATION**

7.1 The vendor shall carry out total installation work as per the requirements of the complete specification and instructions of Engineer. Notwithstanding any stipulations of this section of specification, any additional requirements stipulated in Section-C shall be taken care of.

7.2 The installation work shall be carried out in a neat workman-like manner by skilled, experienced and competent workmen, particularly with experience in jointing and termination of aluminium/copper conductor cables with XLPE/PVC/Elastomeric insulations.

7.3 Cable installation shall be properly coordinated at site with other services and wherever necessary suitable adjustment shall be made in the cable routings with a view to avoid interference with any part of the building, structures, equipment, utilities and services Any such adjustment shall be done with the approval of Engineer.

7.4 All materials, equipment, instruments, hardware, tools, consumables, fasteners, accessories etc whether specifically mentioned or not in the specification but required for complete installation and testing in all respects and to the satisfaction of the Engineer will be in the scope of vendor and no extra cost shall be paid for the same.

7.5 The vendor shall provide at no extra cost, skilled and unskilled labour, supervisory and administrative personnel, erection tools and tackles, transport vehicles and transport cranes, equipment for erection, testing and commissioning and implements necessary for timely and efficient execution of the contract.

7.6 For items to be supplied by the purchaser, the vendor shall at no extra cost to purchaser, take delivery (from stores, unloading bay etc.) of the items, transport safely to site of erection, undertake opening and inspecting the material and reporting damages. He shall also be responsible for storing the same at plant site with suitable weather protection.

- 7.7 All materials being supplied or consumed during erection by the vendor in the process of erection work shall be of the best quality and according to the relevant standards. All materials shall be got inspected and approved by the Engineer before the same is used for erection work. Also regarding the inspection of work the purchaser shall have the right to inspect the same at any time during erection, testing and commissioning.
- 7.8 All apparatus, connections and cable work shall be designed and arranged to minimise the risk of fire and ingress of water. All material required to achieve the same shall be included in the cost of installation of cables.
- 7.9 The drilling and welding of building steel work for fixing supports and brackets will not be done without the prior approval of Engineer.
- 7.10 Any work like chipping/breaking of existing structure like walls, floors, fabrications, etc. shall be done after taking prior approval of Engineer.
- 7.11 Motors for all mechanical equipment for the process like, pumps, fans etc. will be set in place by other agencies. The vendor shall make power, space heater and auxiliary cable connections to the equipment and shall work in complete coordination with other vendors and/or equipment suppliers/ representatives in obtaining correct direction of rotation and the commissioning of the equipment.
- 7.12 The below listed jobs shall also be considered as normal jobs and shall be carried out by the vendor at no extra cost to the purchaser and to the satisfaction of Engineer.
- a) Modifications such as rotating the terminal box through 90 deg or 180 deg as required.
  - b) Enlargement of cable entry holes, if necessary, by chipping and finishing the same properly.
  - c) Drilling of gland plates of equipment if not done already.
  - d) Reasonable amount of drilling, cutting, reaming and relocating holes at actual point of entry of cable or conduit in terminal boxes, outlet boxes, pull boxes etc, cleaning off the debris/trapped material from conduit/ducts.
  - e) Supply of all cement, sand etc, required for grouting necessary supports for cable trays, conduits etc.
  - f) Sealing of all openings between conduits/pipes and the encasing wall/ floor.
  - g) All supporting and clamping arrangement.
  - h) In case any existing structure is affected/damaged due to installation work of cables the vendor shall repair the same to the satisfaction of Engineer.
  - i) Changes in line and grade or addition of off-sets by means of cutting standard tray sections and inserting additional tray fittings to match with the existing arrangement.
  - j) Small modifications in the cable tray routings.

- k) Cleaning and minor chipping work, dewatering of trenches if necessary, minor civil works and other associated works. Securing the supports on walls, ceilings, floor or trenches by suitable anchoring may also have to be done, if required.
  - l) All excavations shall be back filled to the original level with good consolidation.
  - m) Any wrong erection shall be removed & re-erected promptly to comply with the design requirements to the satisfaction of Engineer.
  - n) All steel items which are not galvanized or areas where galvanization has been affected in the course of fabrication and erection shall be given at least two coats of anti-corrosive paint. The quality of paint shall be to purchaser's approval. Anti corrosive paint (zinc paint) shall be applied after applying red oxide paint.
  - o) Looping of cores/wires at terminals as per interconnection diagrams.
- 7.13 While testing and commissioning if the system to which the cabling is connected is observed to be not functioning, it shall be the responsibility of the vendor to check, establish and demonstrate in close coordination with the commissioning agencies that there is no defect in the cabling. The vendor shall put his supervisor and workmen along the commissioning agencies to check the interconnecting cables.
- 7.14 Any modification/rework required to be done on account of wrong practices (like connections with wrong sequence at drive/equipment end) shall be at vendor's cost.
- 7.15 Before energisation, physical inspection (of Terminal Boxes, Junction boxes etc) shall be carried out and all foreign bodies shall be removed and loose connecting bolts etc. shall be tightened.
- 7.16 Complete cabling work shall be carried out as per following drawings/documents furnished by purchaser and the instructions of Engineer.
- a) Cable trench layout drawings.
  - b) Cable tray layout drawings.
  - c) Cable schedules (covering details like From, To, Route, cable Details etc.).
  - d) Cable interconnection diagrams.
  - e) Relevant civil drawings.
  - f) Equipment layout drawings.

### **16.8.0 UNSPECIFIED WORK**

- 8.1 Vendor shall take up all unspecified work as requested by purchaser for supply and/or erection.
- 8.2 Complete work shall comply with the purchaser's requirements for which specification and completion schedule shall be handed over to the vendor.

8.3 All work shall comply with the applicable standards. All material and workmanship shall be to the approval of Engineer.

8.4 PAYMENT :

- a) SUPPLY : Payment for the supply materials shall be made for actual expenditure incurred as per the vouchers of payment, and certified by the Engineer. An additional 15% shall be paid towards profit and engineering charges.
- b) ERECTION : Already specified in Section 13 .8 in the contract.

#### **16.9.0 PERFORMANCE GUARANTEE**

9.1 Bidder shall guarantee that the system offered shall meet the requirement as indicated in this specification and as confirmed through various clauses of Data Sheets. If it is proved that the system doesn't conform to performance guarantee, the bidder should be ready to replace the faulty components / equipment without any loss or extra cost to the purchaser.

#### **16.10.0 DOCUMENTATION**

10.1 The following information shall be furnished within two weeks of award of contract, for purchaser's approval.

- a) Data Sheet-C.
- b) Final Field Quality Plan.
- c) Quality Plan.

10.2 The following shall be furnished after testing and inspection.

- Test certificates of various tests conducted at site.

10.3 As Built Drawings

After successful completion, testing & commissioning of installation work, purchaser's drawings (cable raceway drawings) and documents (Cable Schedules) shall be updated in line with the actual work carried out at site.

Two marked up copies of the drawings and documents shall be submitted by the vendor within one month of completion of each major activity.

All marked up copies shall have the approval of Engineer at site.

## **DATASHEET A**

### **SPECIFIC TECHNICAL REQUIREMENTS**

1.0 STANDARDS APPLICABLE : As per respective specification

#### SUPPLY ITEMS

2.0 TREFOIL CLAMPS

2.1 Material: Nylon / Aluminium alloy

2.2 Type & Design: Conforming to BHEL's drg. no. PE-4-999-507-021

2.3 Sizes: To suit the ODs of cables and tolerances in ODs.

2.4 Whether short circuit test:  
required on a sample  
selected randomly YES/NO (see section C part-A)

3.0 OTHER CLAMPS

3.1 Material & type: [ ] Nylon self locking ties

3.2 Surface Treatment for steel:  
gms. per Galvanised with weight of zinc not less than 610  
sq. metre.

3.3 Nylon self locking tie strips  
(If specified in 2.1 above)

Usage : Width Tensile strength

- |    |  |              |
|----|--|--------------|
| a) | Collective clamping:<br>upto 35mm OD<br>(max. group of 4 cables) | 4.0mm :30 kg |
| b) | Individual multicore :<br>cable above 35mm OD<br>upto 55mm OD    | 4.0mm :20 kg |
| c) | Individual multicore:<br>above 55mm OD                           | 7.0mm :60 kg |

3.4 Sizes (Other than Nylon ties):To meet the requirements of clause 3.1 of Section D

4.0 FERRULES

a) Colour of ferrules: Yellow / White

b) Colour of engraving: Black

5.0 TAGS

- 5.1 Material: Al. /fiberglass /Stainless steel
- 5.2 Markings: Engraving /Embossing /Printing
- 5.3 Size: As per site approval

## ERECTION

6.0 SURFACE TREATMENT: As per clause 3.5 of Section D and clause 7.0 listed below for the following items as supplied by purchaser with the treatment as indicated.

6.1 Support Material: Hot Dip Galvanized

6.2 Cable Trays

a) Type: Ladder and Perforated

b) Treatment: Hot Dip Galvanized

7.0 SITE SURFACE TREATMENT AFTER ERECTION OF TRAY & SUPPORT MATERIAL

7.1 Support Material

a) If already Galvanized : Two coats of cold zinc paint at welded joints and touch up where needed.

7.2 Cable Trays, tray covers and accessories

a) If already Galvanized: Two coats of cold zinc paint at welded joints and touch up where needed.

8.0 SUPPORT SPACING

8.1 Angle iron support for trays

a) Horizontal runs: 2000 mm (max.)

b) Vertical/inclined run: 1000 mm (max.)  
spacing

9.0 VERTICAL SPACING BETWEEN TRAYS: 300 mm

10.0 CLAMP SPACING

10.1 Trefoil clamps

a) Horizontal run spacing: 1000 mm (max.)

b) Vertical run spacing: 1000 mm (max.)

c) Axial spacing between: Double the diameter of larger adjacent trefoils cable or 150 mm whichever is less.

## 10.2 Other Clamps

### 10.2.1 Power cables

#### a) above 35 mm OD

i) Horizontal runs: Individually clamped at 3000 mm interval (max.)

ii) Vertical runs: Individually clamped at 1000 mm interval (max.)

#### b) upto 35 mm OD

i) Horizontal runs: Collectively clamped at 3000 mm interval (max.)

ii) Vertical runs: Collectively clamped at 1000 mm interval (max.)

### 10.2.2 Control Cables

i) Horizontal runs: Collectively clamped at 3000 mm interval (max.)

ii) Vertical runs: Collectively clamped at 1000 mm interval (max.)

## 11.0 SPACING FOR CABLES SUPPORTED ALONG STRUCTURE/CEILING

### a) Clamp spacing

i) in horizontal runs: 750 mm (max.)

ii) in vertical runs: 750 mm (max.)

### b) Spacing between cables: 30 mm (min.)

#### NOTE:

a) Supports shall also be provided at each bend.

b) For any change in above spacing, prior approval of Engineer will be taken.

## 12.0 BURIED CABLES

a) Scope: Required

b) Depth of laying: As per IS: 1255

c) Type of protective covering: Conc. Slabs

## 13.0 OTHER CONDITIONS OF INSTALLATION IN SPECIFIC AREAS

13.1 Sand filling of trenches: YES  
required

13.2 Fire barriers required: COVERED ELSEWHERE

BHARAT HEAVY ELECTRICALS LIMITED : PSWR : NAGPUR  
TENDER SPECIFICATION No. BHE/PW/PUR/SLT-CBL/538

13.3 Scope of earthing of support: By vendor /material Covered in above ground earthing specification

#### 14.0 CABLE TERMINATION

##### 14.1 Type of lugs

- a) Power cables: See section C clause no 4.1 (xxi)
- b) Control Cables: See section C clause no 4.1 (xxi)

##### 14.2 Type of glands

- a) Material: Brass
- b) Type: Double compression non-Insulated type

#### 15.0 WASTAGE ALLOWANCE

- a) HT cables: 1%
- b) LT cables above 70 mm<sup>2</sup>: 1%
- c) LT cables upto 70 mm<sup>2</sup>: 2%
- d) Control & special cables: 3%
- e) Fire Survival cables: 1%
- f) Steel materials: 1% by weight  
(For cable trays/  
tray support installation/  
supplied by vendor.)

#### 16.0 Purchaser's drawing list :

- a) PE-4-999-507-021 Trefoil cable clamp

## DATASHEET C

### **GURANTEED TECHNICAL PARTICULARS ( TO BE SUBMITTED BY SUCCESSFUL BIDDER)**

- 1.0 GENERAL
- 1.1 Name of the vendor:
- 1.2 Address:
- 2.0 Standards Applicable
- |      |         |  |     |
|------|---------|--|-----|
| 2.1  | IS:1255 | For installation of cables:                | YES |
| 2.2  | IS:732  | For wiring installation:                   | YES |
| 2.3  | IS:2062 | For structural steel:                      | YES |
| 2.4  | IS:800  | For use of structural steel:               | YES |
| 2.5  | IS:316  | For metal arc welding:                     | YES |
| 2.6  | IS:1363 | For Hexagonal bolts, nuts and screws:      | YES |
| 2.7  | IS:1572 | Electroplated cadmium coatings:            | YES |
| 2.8  | IS:2629 | For hot dip galvanizing                    |     |
| 2.9  | IS:2633 | For testing uniformity of zinc:<br>coating | YES |
| 2.10 |         | Indian Electricity Rules:                  | YES |
- 3.0. SUPPLY ITEMS
- 3.1 TREFOIL CLAMPS
- 3.1.1 Material:
- 3.1.2 Type & Design:
- 3.1.3 Sizes:
- 3.1.4 Whether short circuit test:  
already conducted
- 3.2 OTHER CLAMPS
- 3.2.1 Material & type:  Nylon self locking ties

BHARAT HEAVY ELECTRICALS LIMITED : PSWR : NAGPUR  
TENDER SPECIFICATION No. BHE/PW/PUR/SLT-CBL/538

as per clause 3.1 of Section D

3.2.2 Surface Treatment of steel:  
clamps

- a) Type: Galvanized / Ungalvanized
- b) Weight of zinc: gms./sq. m

3.2.2 Nylon self locking tie strips  
(If specified in 2.1 above)

- |    | Usage:   | Width | Tensile strength |
|----|--|-------|------------------|
| a) | Collective clamping:<br>upto 35mm OD<br>(max. group of 4 cables) | mm    | kg               |
| b) | Individual multicore:<br>cable above 35mm OD<br>upto 55mm OD     | mm    | kg               |
| c) | Individual multicore:<br>above 55mm OD                           | mm    | kg               |

3.3 FERRULES

- a) Colour of ferrules:
- b) Colour of engraving:

3.4 TAGS

- 3.4.1 Material: Al. /fiberglass /Stainless steel
- 3.4.2 Markings: Engraving /Embossing /Printing
- 3.4.3 Size:

4.0 ERECTION

4.1 Surface Treatment of purchaser supplied items

- a) Support Material:
- b) Cable Trays:

4.2 Support Spacing

4.2.1 Cantilever arm support for trays

- a) Horizontal runs:
- b) Vertical/inclined run:  
spacing

#### 4.2.2 Vertical spacing between trays:

#### 4.2.3 Clamp Spacing

- a) Trefoil clamps
  - i. Horizontal run:
  - ii. Vertical run:
  - iii. Axial spacing:  
(between adjacent trefoils)
- b) Other Clamps
  - i. Power cables (above 35 mm OD)
    - A. Horizontal runs:
    - B. Vertical runs:
  - ii. Power Cables (upto 35 mm OD)
    - A. Horizontal runs:
    - B. Vertical runs:
  - iii. Control Cables
    - A. Horizontal runs:
    - B. Vertical runs:

#### 4.2.4 Spacing for cables supported along structure / ceiling

- a) Clamp spacing
  - i. in horizontal runs:
  - ii. in vertical runs:
- b) Spacing between cables:

#### 4.2.5 Buried cables

- a) Depth of laying:
- b) Type of protective:  
covering

#### 4.2.6 Other conditions of installation in specific areas

BHARAT HEAVY ELECTRICALS LIMITED : PSWR : NAGPUR  
TENDER SPECIFICATION No. BHE/PW/PUR/SLT-CBL/538

- a) Sand filling of trenches considered: YES  
considered
- b) Fire barriers considered: NO
- c) Scope of earthing of support material: Included support material

## 5.0 CONFIRMATION

- 5.1 Vendor to confirm that installation practice: YES  
in terms of scope, workmanship, technical requirements and pre- & post-installation shall conform to requirements of Section C & D and Data Sheet A of Vol IIB.

## 6.0 DOCUMENTATION

Whether following enclosed for purchaser's approval

- a) All relevant drawings: YES/NO
- b) Purchaser's drawings with bidder's: YES/NO  
signature and seal
- c) Quality Plan( where applicable): YES/NO
- d) Final Field Quality Plan: YES/NO

## CABLING ERECTION PHILOSOPHY

### 1.0 Scope

- 1.1 This document is intended to cover the aspects of cable raceway design and installation, laying and termination of various types of cables for the project.
- 1.2 Design calculations for cable sizing and selection are covered in a separate document.
- 1.3 Latest revisions of all drawings / documents shall be referred.

## **2.0 Cable Raceway System**

- 2.1 Cables shall generally be laid in galvanised MS cable trays in multi-tier arrangement. The trays shall in turn be supported on flexible cable tray support systems in cable vaults, along structural members/ concrete surfaces inside plant buildings, cable trenches below switchboards/ MCCs in auxiliary plant buildings, and interconnecting pipe-cum-cable trestles. The trays shall be fixed to supports by means of bolting. Clamping of trays to the cantilever arms shall be resorted to where due to fabrication mismatches, there are misalignments between the respective locations of holes in trays and the cantilever arms.
- 2.2 Cable trays shall be oriented horizontally in all areas, except in areas subject to coal dust or ash deposition (such as boiler platforms, raceways along C-row of Main Power House area, interconnecting overhead cable tray paths between boiler area and ESP area, etc). Cable trays may be oriented vertically in other areas also if so required due to reasons such as space restriction, accessibility, plant aesthetics, operational clearances, etc. as per approved layout drawings.
- 2.3 Cable trays shall be ladder type for power and control cables, while perforated type cable trays shall be used for instrumentation cables. However, in vertical cable tray risers, all trays shall be ladder type.
- 2.4 Suitable cable tray accessories such as horizontal and vertical bends, crosses, tees, reducers etc. shall be used in conjunction with straight runs of cable trays wherever required as per approved layout drawings to ensure a continuous and break-free tray support system for cables.

Cable tray accessories shall be factory fabricated for use at site as per approved drawing titled "TYPICAL DETAILS OF CABLE TRAYS AND ACCESSORIES", (drawing no. PE-DG-214-507-E002). For specific site requirements (e.g. irregular angle bends such as 30°/60° bends, etc) as per layout conditions, tray accessories shall be fabricated at site from the straight length of respective sizes as required. Galvanisation damaged during cutting / welding operations shall be made good with cold galvanisation paint to be applied before installation of the accessories.

- 2.5 The flexible cable tray support system shall comprise of galvanised MS single channel (SC1) or double channel (DC1) members as main supports, to which galvanised MS cantilever arms of sizes commensurate with the tray being supported shall be fixed by means of spring nuts. Along overhead cable tray paths employing trays installed in vertical orientation, trays may be fixed directly to the vertical channel supports (e.g. along cable trestles) through bolting/ clamping.
- 2.6 Cable tray risers in plant buildings shall be supported on cage structures made from double channels as vertical members along the four vertices of a rectangle and single channel horizontal members connected to the vertical members at every 1000mm. Each tray of the risers will be fixed directly to one horizontally fixed single channel available at every 1000mm within this cage.

- 2.7 The main supports (single/ double channels) shall be fixed to concrete/ steel surfaces by means of clamps/ brackets with spring nuts. The clamps/ brackets shall be fixed to the corresponding surfaces as permitted by site conditions in any of the following ways as per approved Document No. PE-DG-214-507-E006, Installation Details for Metal Channel Boltable Cable Support Systems:
- a) Fixed with anchor bolts directly to concrete surface
  - b) Welded to steel inserts where available in the concrete surface
  - c) Clamped to steel structural members
  - d) Welded to steel structural members (except vertical bracings)-wherever clamping is not possible.
- 2.8 Running lengths of single / double channels shall be cut to required lengths for installation. Galvanisation damaged due to cutting shall be repaired with cold galvanisation paint prior to installation.
- 2.9 Single channels in vertical orientation, when fixed from both top and bottom, shall be used for supporting up to and including three trays. When supported from one end only, no more than two trays shall be supported on a vertically oriented single channel. Single channel in horizontal orientation shall similarly be used for supporting up to and including three trays with two points clamping. For supporting more than three trays the single channel shall be clamped once for every two trays symmetrically between two trays. In case clamping in this fashion is not possible, double channel with two point clamping shall be used.
- 2.10 Inside main cable vaults, as well as in other areas where more than three trays are supported on both sides of the double channel (double channels in vertical orientation), the channels shall be fixed both at the top as well as the bottom for main runs. Double channels supported from either the top or bottom and installed in vertical orientation, shall be used for supporting up to and including three trays either on one or both sides. For cross runs in cable vaults, single/ double channel supports as required as per approved layout drawings supported only from the top shall be used.
- 2.11 Horizontal runs of cable trays shall be supported at intervals of 2000mm approximately. Vertical runs (risers) shall be supported at approximately every 1000mm interval. Spacing between cable trays shall normally be kept 300mm for cable laying convenience and effective heat dissipation. However, wherever layout constraints do not permit this spacing, the same may be reduced to 250mm, for trays carrying control and instrumentation cables. The cable tray numbering shall be provided at every 10 meter and at each end of cable tray & branch connection.
- 2.12 All galvanisation damaged due to cutting/ welding operation required to be carried out for the installation of the system (trays, accessories and support system) shall be made good with application of cold galvanisation paint.
- 2.13 The cable trays and supports system shall be type tested, of approved makes, and conforming to their respective approved drawings.

- 2.14 Cable trays shall be grounded as per the provisions of the approved grounding document for the project.
- 2.15 For laying cables along building steel structures or masonry structures, the cables shall be fixed by clamping with GI saddles screwed to the GI flats welded/ embedded to the structures.
- 2.16 For laying cables along concrete walls, ceilings etc., the cables shall be clamped with GI saddles screwed to the GI flats welded to the inserts. Where inserts are not available the saddles may be directly fixed to the walls using anchor bolts and MS flat spacers of minimum 6mm thickness.
- 2.17 Provisions of IS: 1255 and CSEB specification shall be followed for cables buried directly in ground. For road/rail crossings, buried HDPE pipes encased in PCC shall be used.  
Directly buried cable shall not have concentration of more than 4 cables. Buried cable routes shall be protected with concrete slabs with route markers at every 20 meters along the route and at every bend.
- 2.18 Cable trays will not pass through wall openings required for interplant cabling. Instead, pipe sleeves in walls as under will be provided for each cable tray for transiting the cables from one side to the other:
- a) For each 600mm wide tray: 3 nos. 200 diameter PVC pipes.
  - b) For each 450/ 300mm wide tray: 2 nos. 200 diameter PVC pipes.
  - c) For each 150/ 100mm wide tray: 1 no. 200mm diameter PVC pipes.
- The trays shall be stopped approximately 200mm short of the wall on both sides and cables passed through the pipe sleeves as above, the pipe sleeves being aligned horizontally with the respective cable trays. This method is adopted for smooth passage of cables and effective sealing of cable openings.
- 2.19 Local cabling in various auxiliary plants or pump houses from the main tray runs to equipment terminal boxes shall be through notches in floor, which will be filled up with sand and then provided with lean concrete covering matching with the floor after completion of cable laying.
- 2.20 In Transformer yard area, cables shall be laid in concrete trenches with RCC covers. The main cable routes coming out from Main plant building and crossing the Transformer yard shall be laid in overhead trestles/duct banks. Minimum clear height of trestle shall be 2.5M and for rail/road crossing, it shall be as rail/road crossing norms.

### 3.0 **General Philosophy of Cable Installation**

- 3.1 Laying, dressing, clamping and jointing/ termination process of power, control and instrumentation cables shall follow the requirements of IS: 1255 & CSEB Technical Specification Volume-II, Part B Sub section :E19.

- 3.2 All precautions as per IS: 1255 & Field Quality Plan (FQP) shall be taken while handling the cables.
- 3.3 Cable runs shall be uniformly spaced, properly supported and protected. All bends in runs shall be as per specification and made with due consideration to avoid sharp bending and kinking of cable. The bending radius of various types of cables shall not be less than those specified by cable manufacturers or that specified in IS: 1255.
- 3.4 For the purpose of cable laying, the cables are categorised as under:
- a) HT: Power cables of 6.6kV/ 3.3kV grade
  - b) LT: Power cables of 0.6/1.1kV grade, catering to loads at 415V AC/ 230V AC/ 220V DC/ 24V DC
  - c) Control: Control cables of 0.6/1.1kV grade generally carrying control signals at 220V DC/ 110V AC.
  - d) Instrumentation: (Also called screened control cables): Screened cables of cross-sections 1.5sqmm or lower generally carrying very low voltage very low current signals.
- 3.5 All cables shall be provided with identification tags indicating the cable numbers in accordance with the cable circuit schedule. Cable tags shall be fixed at terminal ends, at tray intersection / bend and at each side of floor/ wall/ duct crossings etc and at every 20m in cable trench/tray or buried run.
- 3.6 Single core cables for a. c. three phase circuits, when laid on trays, shall be in trefoil formation (each trefoil with RYB phases formation), with each trefoil two 'D' apart from the next trefoil in the tray. The trefoil formation shall be duly secured to the cable tray by means of trefoil clamps of nonmagnetic material at every 1000mm interval. 'D' is the diameter of cable.
- 3.7 Multi-core cables above 1100 V grade when laid on trays, shall be in one layer, touching and clamped by means of nylon cable ties.
- 3.8 1100 V grade multi-core power cables carrying continuous current when laid on trays shall be placed in single layer, touching and clamped by means of nylon cable ties. Cables of sizes indicated below, shall be clamped individually.
- (a) Single core cables : 500 sq mm or higher ( when not laid in trefoil formation- e.g. dc circuits)/ neutral cables)
  - (b) Two core cables : 120 sq mm or higher
  - (c) Three core cables : 95 sq mm or higher
  - (d) Three & half core cable: 95 sq mm or higher
- 3.9 Control and instrumentation cables shall be laid in multi layers, but not exceeding three layers in any section. Special purpose cables (e.g. IPB, WAN etc.) shall be laid as per system manufacturer/ supplier recommendations with due regard to segregation of routes for redundant circuits.

- 3.10 While power, control and instrumentation cables shall generally be laid in separate trays, low current carrying power cables (valve/ damper actuator power cables) may be laid along with control cables. In most such cases, the cable sizes shall be 2.5 sq mm; however, in exceptional cases higher sizes as per approved cable sizing calculations (required due to voltage drop criterion) may be used.
- 3.11 Cables shall be placed on trays on the basis of their types and functions as under for horizontal formations:
- a) HT cables: in the top tier(s).
  - b) LT power cables: in the tray(s) below the HT cable trays.
  - c) Control cables: in the tray(s) next below to the LT power cable tray(s).
  - d) Instrumentation cables (screened control cables): in the bottom most tray(s).

HT Power, LT Power and LT Control/Instrumentation cables shall be separated from each other by atleast 300mm.

- 3.12 For vertical formations, the outermost tray shall be considered as the topmost tray and the order indicated in clause 3.11 shall be followed. In rare cases, where there is no clear distinction of bottom/ top trays, the order convenient for linking the horizontal and vertical formations avoiding criss-crossing, or exit of cables shall be followed.

Typical examples of tray numbering are given overleaf.

- 3.13 Wherever it is not possible to accommodate cables as per the criteria indicated in the clauses 3.11 & 3.12 (due to layout constraints) for very short field runs, control cables may be laid in the same tray with the instrumentation cables with clear minimum gap of 100mm between the two types of cables.

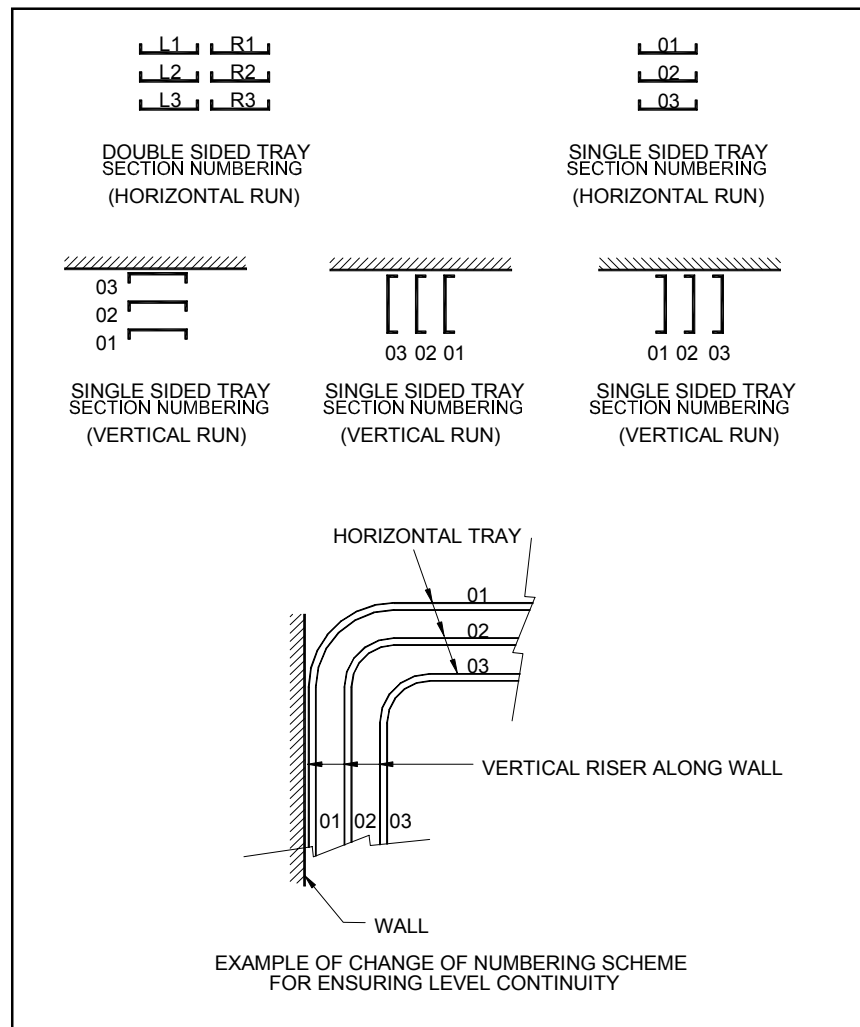

- 3.14 All cables associated with the unit shall be segregated from cables of other units. Interplant cables of station auxiliaries shall be laid in such a way that not more than half of the drives are lost in case of single incident of fire. Power and Control cables for ac drives and corresponding ac or dc drives shall be laid in segregated routes. Cable route for one set of auxiliaries of same unit shall be segregated from the other set. Segregation means physical isolation to prevent fire jumping or minimum one hour fire rating. Cables of unit critical drives shall be segregated in such a way that not more than half of the drives are lost in case of single incident of fire. In switchyard, control cables of each bay shall be laid on separate racks / trays.
- 3.15 To facilitate pulling of cables in GI conduits, powdered soft stone, plastic soap or other dry inert lubricant may be used. However any material harmful to the cable sheaths shall not be used.
- 3.16 No single core cable shall pass through a GI conduit/ pipe or duct singly except DC single core cables. AC single core cables shall pass through GI conduit/ pipe in trefoil formation only, or through PVC pipes. Conduit/pipe occupancy shall not exceed 40% of the conduit/pipe cross-section area. Pipes/ conduits if used in corrosive areas shall have anti-corrosive coating both inside & outside.
- 3.17 Wherever specific cable routes are not shown in cable schedules, cables may be laid through the shortest route as per the above criteria, as directed by site Engineer.

3.18 Cable clamping spacing for cables laid in cable trays shall be generally as under:

(a) Trefoil clamps:

- 1) Horizontal run spacing: 1000 mm (max.)
- 2) Vertical run spacing: 1000 mm (max.)

(b) Other Clamps

1. Power cables of sizes indicated under

- (i) Single core cables: 500 sq mm or higher  
(when not laid in trefoil formation- e.g. dc circuits)
- (ii) Two core cables: 120 sq mm or higher
- (iii) Three core cables: 95 sq mm or higher
- (iv) Three & half core cable: 95 sq mm or higher  
Horizontal runs: Individually clamped at 3000 mm interval (max.)  
Vertical runs: Individually clamped at 1000 mm interval (max.)

2. Power cables of other sizes

- Horizontal runs: Collectively clamped at 3000 mm interval (max.)
- Vertical runs: Collectively clamped at 1000 mm interval (max.)

3. Control Cables

- Horizontal runs: Collectively clamped at 3000 mm interval (max.)
- Vertical runs: Collectively clamped at 1000 mm interval (max.)

3.19 Clamp spacing for cables supported directly along structure/ ceiling shall be as under:

a) Clamp spacing

1. In horizontal runs: 750 mm (max.)
2. In vertical runs: 750 mm (max.)

b) Spacing between cables: 30 mm (min.)

- c) Supports shall also be provided at each bend.
- 3.20 Fire sealing system rated for one hour and based on suitable block system (using individual blocks with suitable framework) or Room Temperature Vulcanising (RTV) Silicon foaming system of approved make/ source shall be provided for all cable penetrations in walls, floors and below panels. However, fire-sealing system shall not be provided below panels mounted on trenches in auxiliary plant areas.

#### **4.0 Cable Termination & Jointing**

- 4.1 Termination and jointing of cables shall conform to the requirements of IS: 1255 and shall be carried out as per the recommendations of termination and jointing kit supplier. Cable terminations at various electrical and electronic equipment terminals shall be done as per approved scheme/ interconnection diagrams. Joints for less than 250m run of cable shall not be provided. Extra length shall be provided for one LT and two HT joints at a later stage.
- 4.2 When the equipment are supplied with undrilled gland plates for cable/ conduit entry into the equipment, all drilling & cutting on the gland plate and any minor modification work required to complete the job shall be carried out at site as per cable glanding requirement. A plan showing the holes for cable entry in the gland plate shall be developed at site in consultation with site engineer for drilling holes (gas cutting is not allowed). Types of glands to be used are as under.
- I. Material: Nickel- Chromium plated brass, heavy duty conforming to BS: 6121
- II. Type: Double compression
- 4.3 Termination of cables shall be done as per termination drawings & interconnection diagrams furnished. Shorting & looping of cores/ wires at terminals and between the panels if required shall be carried out as per approved scheme.
- 4.4 All cable entries in the equipment shall be sealed by cable glands supplied with the equipment. Any discrepancy in cable glands/ lugs with respect to cable size shall be brought to the notice of site engineer.
- 4.5 Adequate length of cables shall be pulled inside the switchboards, control panels, terminal boxes etc so as to permit neat termination/ dressing of each core/ conductor.
- 4.6 Power cable terminations shall be carried out in specified manner to avoid strain on the terminals.
- 4.7 Control cable cores entering switchboard or control panels shall be neatly bunched and strapped with PVC tapes/ nylon ties and suitably supported to keep them in position at the terminal block. All spare cores shall be neatly dressed and suitably grounded/ insulated with blank ferrules.
- 4.8 Screened control cables of small cross sectional area, (0.5 sq mm) shall be terminated by means of cage clamp termination system.
- 4.9 Individual cores of control cables shall have ferrules for identification. Ferrule numbers shall be provided as per the control schemes and other related documents.

4.10 Termination and jointing of HT cables shall be done with heat shrinkable/ Push-on/ Taped type/ elastimold or equivalent fully insulated pre moulded type termination/ jointing kits of proven design & type tested as per IS : 13573.

4.11 Termination of aluminium/ copper conductor cables shall be done by means of suitable tools as indicated below:

Type of lugs

I. HT Power Cables: As per DIN 46329

II. LT Power Cables : Tinned copper (solderless crimping type)

III. LT Control Cables : Tinned copper (solderless crimping type)

4.12 Cable joint(s) shall normally be made at an appropriate point (s) in the straight run of cables only when the length of the run is more than the standard drum length supplied by the cable manufacturer, or when a joint is necessitated due to site constraints. In such cases, when jointing is unavoidable, the same shall be made by means of specified cable-jointing kit. Prior approval of Engineer shall be taken for deciding location of joint.

4.13 Junction boxes may be used, wherever required, for jointing/ marshalling of control and instrumentation cables.

4.14 Screened control cables for circuit breaker control/ indication/ measurement functions from switchgear/ MCCs to DDCMIS system/ Electrical Control Panel (ECP) shall be marshalled if required, as under:

a) Individual cables from a number of adjoining/ close-by switchgear panels of a switchboard to a junction box located in the respective switchgear room.

b) Trunk cables from the junction box (s) to DDCMIS panels/ ECP.

Typical arrangement is shown below.

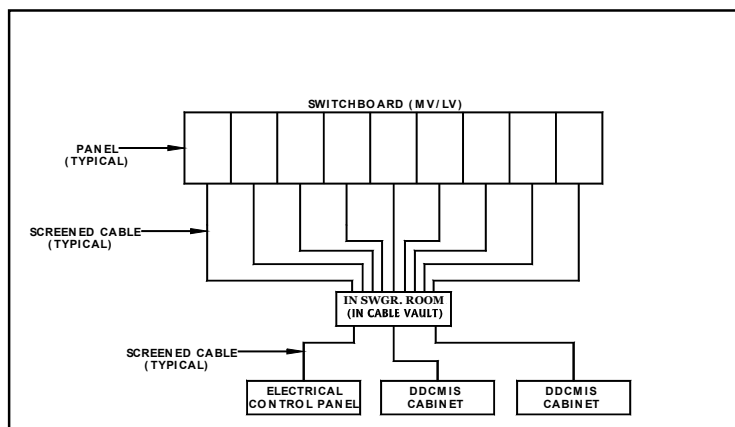

## **5.0 Grounding of Cabling System**

- 5.1 Grounding of cable support system shall be as per approved grounding documents for cable tray support structures, cable trays, conduits and pipes. All the conduits, trays and support structure on which the cables are laid shall be bonded to the main grounding system. All the support arrangement shall be tested for electrical continuity and permanent connection to earth. Gas/ water or other pipes shall not be used as grounding medium.
- 5.2 Armour grounding:
- a) Armour of the HT cables and LT single core cables shall be grounded only at one end of cable.
  - b) Armour of other cables shall be grounded at both ends of cable.
- 5.3 Screen Grounding:
- a) Screen of multi-core cables shall be grounded at both ends.
  - b) Screen of single-core power cables shall be grounded at one end.
  - c) Screen of electronic grounding system cables shall be grounded as per the Control System panel manufacturer recommendation.

## **6.0 Testing Of Cable Installation**

- 6.1 Testing of cables during pre-erection, pre-commissioning and post commissioning stages of the cabling system shall be carried out under the overall supervision of the Engineer. It shall be ensured to complete all activities in coordination with equipment commissioning agency keeping in view the overall commissioning programme. A checklist for testing and commissioning activities shall be prepared in consultation with site engineer and the activities shall be carried out in accordance with the agreed checklist.
- 6.2 Testing and electrical measurement of cable installations shall conform to the requirement of IS: 1255.
- 6.3 Prior to installation, cables shall be tested for
- a) Continuity of conductors for all cores of cables.
  - b) Insulation resistance between conductors and earth.
  - c) Insulation resistance between conductors of multi core cables.
- 6.4 Pre installation checks for cable tray installation shall be as under:
- a) Availability of clear passage/ path for the cable tray network as per approved drawings.
  - b) Cold galvanisation / paint treatment for all damaged portions of galvanisation due to cutting / repairs etc.

- c) Correctness of installation of number and type of tray / tray accessories /support material as per approved drawings.
- d) Firmness/ tightness of all bolted joints
- e) Alignment / inter tray separation as per approved layout drawings.
- f) Grounding connections for trays / cable boxes / marshalling boxes

6.5 After installation cables shall be tested for

- a) Continuity of conductors for all cores of cables.
- b) Insulation resistance between conductors.
- c) Insulation resistance between conductors & earth.  
Check for earth continuity for armour / screen (where applicable).  
and proper earth connection for cable glands, cable boxes etc.
- d) DC High voltage test (for all HT cables & LT power cables of sizes 300 sq. mm and above).
- e) Check for correct polarity & phasing of cable connections
- f) Firmness/ tightness of terminations.
- g) For correctness of all connections as per relevant wiring diagram.
- h) For provision of correct cable tags, core ferrules etc.

6.6 All documents/ records regarding test data and all other measured values shall be duly vetted by the site Engineer before energizing the circuit and kept for future record and reference. The results of all tests shall conform to the specification requirements as well as any other specific performance guarantee.

## **7.0 Additional Points Of Consideration**

7.1 The installation work shall be carried out in accordance with the specifications, and instructions of Engineer. Notwithstanding any stipulations of this document, any additional statutory or regulatory requirements as applicable shall be taken care of.

7.2 The installation work shall be carried out with neat workmanship by skilled, experienced and competent workmen, particularly with experience in jointing and termination of aluminium/ copper conductor cables with XLPE/PVC/ Elastomeric insulations.

7.3 Cable installation shall be properly coordinated at site with other services and wherever necessary, suitable adjustment/ modification shall be made in the cable routings with a view to avoid interference with any part of the building, structures, equipment, utilities and services. Any such adjustment shall be done with the prior approval of Engineer.

- 7.4 The drilling and welding of building steel work for fixing supports and brackets will not be done without the prior written approval of Site Engineer.
- 7.5 Any work like chipping/ breaking of existing structure like walls, floors, fabrications, etc. shall be done after taking prior written approval of Site Engineer.
- 7.6 Complete cabling work shall be carried out as per following approved drawings/ documents and also the instructions of Engineer, if any.
- a) Cable tray layout drawings.
  - b) Typical cable tray and support installation drawings.
  - c) Cable schedules.
  - d) Cable interconnection diagrams.
  - e) Relevant civil drawings.
  - f) **Equipment layout drawings.**

## Appendix-IIA

List of **T&P** to be made available **by BHEL** free of hire charges (on sharing basis).

01	EOT crane in TG hall shall be made available on sharing basis for handling panels	1 no
02	Tyre-Mounted Crane 8 MT Capacity	1 no.

### Note:

Above T&P will be provided for specific erection/commissioning activities wherein these equipment will be required. While taking delivery, contractor shall check for proper working of the equipment and the same shall be returned after the work is completed to BHEL stores in good working condition subject to normal wear and tear.

Tyre-mounted crane will be made available on sharing basis for loading/unloading at stores and site for handling heavier components. Operator, fuel and lubricants shall be arranged by the contractor or contractor shall share the cost. BHEL will provide spare parts in case of breakdown not attributable to the contractor (accidental damage, regular wear & tear). Contractor shall carry out regular preventive maintenance. Filters for Fuel and Oil will be provided by BHEL.

While all effort will be made for amicable sharing of the above, non-availability of the above due to any reason shall not absolve the contractor of performing his responsibilities in time. The contractor shall undertake sufficient pre-planning and arrange his own handling/transport equipment as deemed necessary.

## **APPENDIX-II**

### **CONSUMABLES/ITEMS TO BE PROVIDED BY BHEL FREE OF CHARGE**

01) CABLE GLANDS

02) LUGS BEYOND 4 sq. mm. SIZE.

## APPENDIX-III

### Tentative List of Major T&P and MMD to be Deployed by the Contractor

#### A. T&P FOR ELECTRICAL WORKS

SN	DESCRIPTION	MINIMUM QUANTITY
0109	HV TEST KIT AC, 0 –50 KV &DC, 0- 100 KV PREFERSBLY WITH DRY TYPE TRANSFORMER	1 NO. EACH
1022	SOLDERING IRON “SOLDRON” MAKE 25 WATT	2 NOS.
1403	MULTIMETRES	
04	A)DIGITAL 3 1/2 DIGIT OF REPUTED MAKE B) ANALOG MOTWANE MAKE	4 NOS. 3 NOS. 1NO.
05	INSULATION TESTER HAND OPERATED 250V/500V/1000 V RATED MAINS/BATTERY OPERATED	1 NO. EACH
06	INSULATION TESTER MAINS OPERATED 2500/5000V	1 NO.
07	PHASE SEQUENCE INDICATOR	1 NO.
08	TONG TESTER AC 5/10, 25/60/300 AMP RANGE REPUTED MAKE	1 NO. EACH
09	TONG TESTER DC 30/60/300 AMP	1 NO.
10	DC RESISTANCE METER	
11	STOP WATCH	1 NO.
12	TARPOLIN FIRE PROOF	As required
13	TELETALK 2 WIRE SYSTEM	6 SETS
14	TORQUE WRENCH (12-60Nm, 50-225 Nm)	1 NO EACH
15	FERRULE PRINTING MACHINE	1 NO

**B. T&P FOR MECHANICAL WORK**

<b>SN</b>	<b>DESCRIPTION</b>	<b><u>MINIMUM</u> QUANTITY</b>
	<b>HANDLING EQUIPMENTS</b>	
1	TURN BUCKLES	AS PER REQMT
2	'D' SHACKLES	AS PER REQMT
3	STEEL WIRE ROPES	AS PER REQMT
4	MANILA ROPES	AS PER REQMT
5	CHAIN PULLEY BLOCK/TIRFUR	AS PER REQMT
	<b>MAJOR T&amp;P</b>	
1	PIPE BENDING MACHINE – 2" SIZE	2 NOS
2	GRINDING MACHINE	2 NOS
3	DRILLING MACHINES 1/4", 1/2", 3/4" & 1"	1 NO. EACH
5	DYE SETS FOR THREADING UPTO 2" PIPE.	2 NOS
6	SPIRIT LEVEL	2 NOS.
7	TAP SETS FOR BOTH BSP AND MPT THREADS UPTO 1" EACH	1 SET EACH
9	WELDING GENERATORS	1 NO.
10	WELDING TRANSFORMER	1 NO.
12	MECHANICAL TOOL KIT FOR FITTERS	4 NOS.
13	ELECTRICIAN TOOL KIT	4 NOS.
14	CRIMPING TOOL UPTO ALL SIZE OF CABLES UNDER SCOPE OF WORK	4 NOS.
15	FLOOD LIGHT FITTINGS	2 NOS.
16	FIRE EXTINGUISHERS	3 NOS.
17	DISTRIBUTION BOARDS WITH POWER CABLE COMPLETE AS REQUIRED	1 SET
18	PAINTING BRUSH	AS PER REQMT.
19	FIRE PROOF TARPAULIN	AS PER REQMT.
20	SAFETY BELTS AND SAFETY HELMETS	AS PER REQMT
21	24V A/C TRANSFORMER & HAND LAMPS	4 NOS.
22	MIG WELDING MACHINE WITH ACCESSORIES AIR COOL TYPE	2 NOS.
23	CRIMPING TOOL HYDRAULIC UPTO 600 SQ.MM	1 NO.
24	TORQUE WRENCH SET	1 SET
25	HYDRAULIC JACKS 250T CAPACITY/100T	4 NOS.EACH
26	TUFFER CAPACITY 15T	2 NOS.
27	CHAIN PULLEY BLOCKS 5/10T	1 NO.EACH

OTHER THAN THE ABOVE, ONE COMPUTER, PRINTER AND OTHER NECESSARY PERIPHERALS WILL HAVE TO BE MAINTAINED BYV THE CONTRACTOR IN HIS SITE OFFICE.

**NOTE:**

BHARAT HEAVY ELECTRICALS LIMITED : PSWR : NAGPUR  
TENDER SPECIFICATION No. BHE/PW/PUR/SLT-CBL/538

THE LIST OF INSTRUMENTS / EQUIPMENTS TO BE BROUGHT BY THE CONTRACTOR AS SHOWN ABOVE SECTIONS A AND B ARE ONLY INDICATIVE. ANY OTHER INSTRUMENTS / EQUIPMENTS REQUIRED FOR THE EXECUTION OF THE WORK IS TO BE NECESSARILY ARRANGED BY THE CONTRACTOR WITHIN THE QUOTED RATES.

THE TESTING/CALIBRATION INSTRUMENTS WHICH ARE USED TO BE DULY CALIBRATED IN THE INTERVAL PRESCRIBED BY BHEL ENGINEERS FROM THE REPUTED AGENCIES DECIDED BY BHEL AND TEST CERTIFICATE TO BE FURNISHED.

## APPENDIX-IV

**MONTHWISE MANPOWER DEPLOYMENT (NUMBER TO BE INDICATED CATEGORY-WISE IN EACH MONTH) BY THE CONTRACTOR.**

SL. NO.	CATEGORY	MONTHS																	
		1	2	3	4	5	6	7	8	9	10	11	12	13	14	15	16	17	so on
01.	RESIDENT MGR																		
02.	ENGINEERS																		
03.	SUPERVISORS																		
04.	RIGGERS																		
05.	FITTERS																		
06.	HP WELDERS																		
07.	STRUCT. WELDERS																		
08.	TIG WELDERS																		
09.	MIG WELDERS																		
10.	ELECTRICIANS																		
11.	INSTRUMENT TECHNICIANS																		
12.	STORE KEEPER																		
13.	SEMISKILLED & UNSKILLED WORKERS																		
14.	WATCHMEN/SECURITY																		

NOTE:

01. MONTHWISE MINIMUM NUMBER OF PERSONS TO BE INDICATED.
02. ABOVE DEPLOYMENT PLAN WILL BE DISCUSSED PRIOR TO START OF WORK AND NECESSARY CHANGES SHALL HAVE TO BE MADE BY CONTRACTOR AS REQUIRED. ANY ADDITIONAL DEPLOYMENT REQUIRED DURING EXECUTION OF WORK SHALL HAVE TO BE MADE BY CONTRACTOR FOR MEETING VARIOUS SCHEDULES/TARGETS SET BY BHEL WITHOUT ANY ADDITIONAL COMPENSATION.

SIGNATURE OF TENDERER WITH SEAL

## APPENDIX-V

### ANALYSIS OF UNIT RATE QUOTED

Sl. No.	DESCRIPTION	Percentage of Unit Rate Quoted	Remarks If Any
01	SITE FACILITIES VIZ., ELECTRICITY, WATER, WORKSHOP AND OTHER INFRASTRUCTURE.		
02	SALARY & WAGES		
03	CONSUMABLES		
04	DEPRECIATION & MAINTENANCE FOR T&P/INSTRUMENTS AND OTHER ITEMS		
05	ESTABLISHMENT & ADMINISTRATION EXPENSES OF SITE		
06	RETRENCHMENT BENEFIT		
07	EXTRA WORK INCIDENTAL TO ERECTION		
08	OVERHEADS		
09	PROFIT		

SIGNATURE OF THE TENDERER WITH SEAL

**APPENDIX-VI**

**Contractor's T&P/MMD Deployment Plan**

SN	DESCRIPTION & CAPACITY OF T&P	MONTHS													
		1	2	3	4	5	6	7	8	9	10	11	12	13	14 and so on*
01															
02															
03															
04															
05															
06															
07															
08															
09															
10															

SIGNATURE OF THE BIDDER

DATE:

- Please use additional sheet if needed.

**APPENDIX-VII  
CONCURRENT COMMITMENTS**

SN	FULL POSTAL ADDRESS OF CLIENT AND NAME OF OFFICER IN-CHARGE	DESCRIPTION OF THE WORK	VALUE OF THE CONTRACT	COMMENC-EMENT DATE	SCHEDU-LED COMPLE-TION	% COMPL-TD. AS ON DATE	ANTICIPA-TED COMPLN. DATE	REMARKS

SIGNATURE OF THE BIDDER  
DATE:

**APPENDIX-VIII**

**DETAILS OF SIMILAR WORK DONE DURING THE LAST SEVEN YEARS**

SN	FULL POSTAL ADDRESS OF CLIENT & NAME OF OFFICER IN CHARGE	DESCRIPTION OF WORK	VALUE OF CONTRACT (Rs.)	DATE OF AWARD OF WORK	DATE OF COMMENCEMENT OF WORK	TIME SCHEDULE (MONTHS)	DATE OF ACTUAL COMPLETION OF WORK	REMARKS

SIGNATURE OF BIDDER WITH SEAL

- PLEASE USE ADDITIONAL SHEET IF NEEDED BUT **IN THE SAME FORMAT.**
- **PLEASE ENCLOSE COPIES OF WORK ORDERS INCLUDING DETAILED BILL OF QUANTITIES, COMPLETION CERTIFICATES IN SUPPORT OF THIS STATEMENT.**