

COIL BEFORE SPREADING

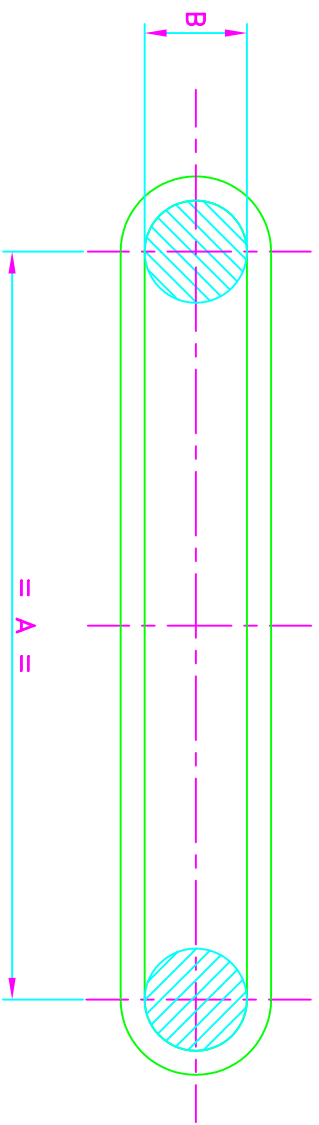

COIL CROSS SECTION

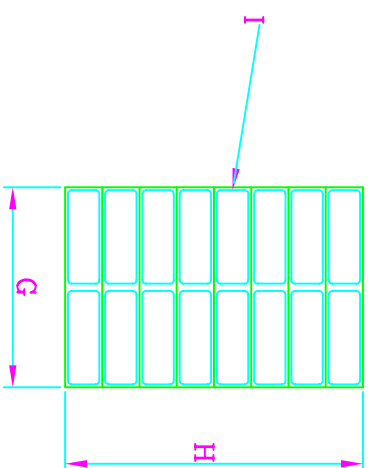

COIL AFTER SPREADING

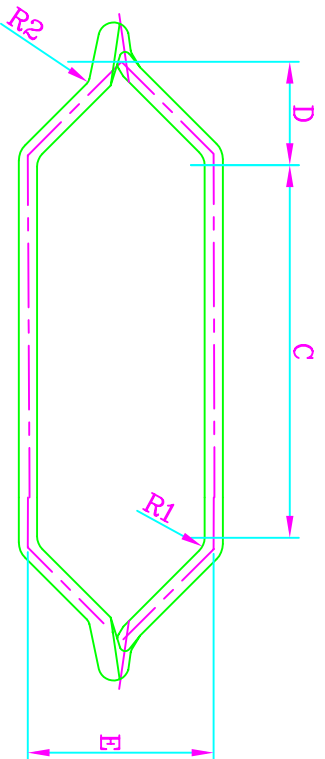

SLOT SKEWING VIEWED FROM CENTRE OF BORE (ANGLE OF SKEW)

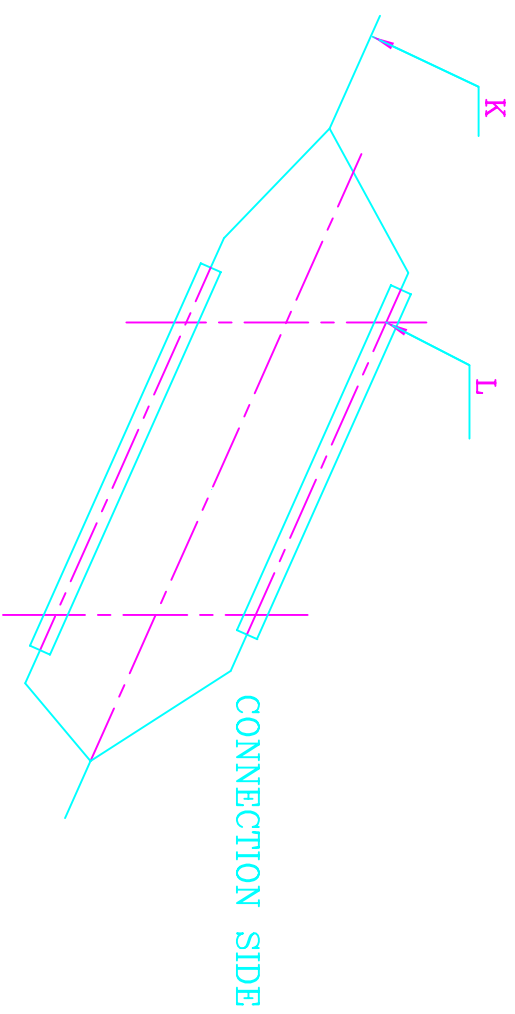

VIEW ON CONNECTION SIDE

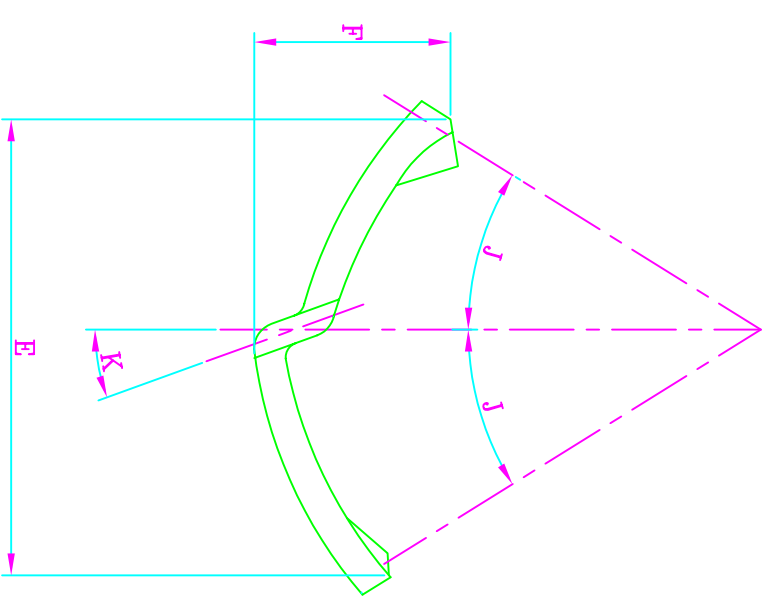

**STATOR COIL SPREADING DETAILS**

Drg.no : 3-EMT-0833/00,

(Enclosure to S-EMT-155, Dt.25.08.2007)



