



Bharat Heavy Electricals Limited
(Seamless steel Tube Plant)
Tiruchirappalli – 620014, TAMIL NADU, INDIA

TITLE: SUPPLY OF WOOD LINERS AS PER DRG	Phone: +91 431 257 8428 Email : rvmurugan@bheltry.co.in Web : www.bhel.com
--	---

Reference Number: 9431352E	Date: 21.02.2014	Due date for submission of application: 14.03.2014
-----------------------------------	-------------------------	---

A. BHEL/SSTP, Trichy is looking for vendors to supply OF WOOD LINERS AS PER DRG
B. Important Note to New Vendors

The new vendors will be required to furnish the following documentary proof/
information (whichever applicable) along with their offers:

1. Certificate of registration (copy of certificate to be submitted).
2. Banker's information (copy of bank pass book first page to be submitted).
3. MSME vendor certificate (if applicable).
4. Address of your organization (complete postal address with PINCODE).
5. Contact person's Phone No. / Mobile No. / FAX No. / E-mail ID.
6. Statutory documents – VAT/TIN/EXCISE REGISTRATION/CST REGN /SERVICE TAX REGISTRATION etc. (copy to be furnished)
7. NSIC/SSI Certificate (if applicable)
8. ISO Certificate (if applicable)
9. Experience certificate as proof of supply of similar items to any Govt. agencies / PSU / Organisations (copy of PO's to be furnished).
10. Audit Report/ IT Return (if applicable)
11. Agency agreement with manufacturer (if applicable)
12. Partnership Deed (if applicable).

If the new vendors fail to submit the above documentary proof/information, their offers will not be considered for this enquiry.

"MSE suppliers can avail the intended benefits only if they submit along with offer, attested copies of either EM II certificate having deemed validity (Two years from the date of issue of acknowledgement in EM-II) or valid NSIC certificate or EM II certificate along with CA certificate (Format enclosed) applicable for the year, certifying quantum of investment in plant and machinery within the permissible limit as per the act for relevant status (Micro or small) where the deemed validity of EM II is over. Date to be reckoned for determining the deemed validity will be the last date of bid submission. Non submission of such documents will lead to



An ISO 9001
Company

Bharat Heavy Electricals Limited **(Seamless steel Tube Plant)**

Tiruchirappalli – 620014, TAMIL NADU, INDIA

consideration of their bids at par with other bidders and MSE status of such suppliers shall be shifted to Non MSE supplier till the supplier submits these documents".

Sr.Manager / Purchase /SSTP
Phone: 0431-257 8428.
Mail: rbmurugan@bheltry.co.in



BHARAT HEAVY ELECTRICALS LTD.
 (A GOVERNMENT OF INDIA UNDERTAKING)
 SEAMLESS STEEL TUBE PLANT
 TIRUCHIRAPPALLI - 620 014,
 TAMIL NADU.

PHONE : 0431-2578480,
 2578547, 2578428,
 2578406
 FAX : 0431-2520464/383

TIN : 33243560005
 CST No. 239383
 Dated 11.06.1991

PURCHASE ENQUIRY

VENDOR CODE	ENQUIRY NUMBER	ENQUIRY DATE	ENQUIRY DUE DATE	No. OF ITEMS
19537	9431352E	21/02/2014	14/03/2014	12

Office Copy

- IMPORTANT POINTS :**
1. Tender Closing Time - 14.00 Hrs.
 2. Tender Opening Time - 15.00 Hrs.
 3. Tender should be submitted in a sealed cover, duly indicating enquiry No., Enquiry date & Enquiry Due Date on the cover.
 4. Offer(s) received through Courier Services after 14.00 Hrs. on Enquiry Due Date will not be considered.
 5. Late tender (s) will be liable for rejection.
 6. Offer(s) shall be valid for 60 days from Enquiry Due Date.
 7. Offer(s) in Vendor's Letter-Head shall contain,
 - a. Offer No. and Date
 - b. Delivery Point
 - c. Delivery Terms
 - d. Payment Terms
 - e. Excise Duty with Tariff Heading Sales Tax (against form-XVII/Form-C), etc.
 - f. Excise Regn. No. and SSI Regn. No.

Kindly arrange to submit your **COMPETITIVE OFFER** for the following item(s).
 If you are not in a position to submit your Offer, kindly arrange to send your **REGRET LETTER**.



THIS IS ONLY A REQUEST FOR OFFER AND NOT AN ORDER

No.	BHEL Material Code and Description	Unit	Requirement	
			Quantity	Delivery
1	BHEL Material Code : SP9022111110 COLLECTING TROUGH WOOD AS PER DRG:4-7-0136-11-00982 KONGU WOOD	Nos.	01 52.000	27/05/2014
2	BHEL Material Code : SP9011129021 WOOD LINER (1435) H-TABLE J11 AS PER DRG.: 4-7-0111-03-04161 REV.00 KONGU WOOD PREFERRED SIZE : 1435 X 285 X 40 MM	Nos.	01 40.000	27/05/2014
3	BHEL Material Code : SP9023111010 COLLECTING TROUGH WOOD LINER AS PER DRG:4-7-0136-11-00983 KONGU WOOD.	Nos.	01 52.000	27/05/2014
4	BHEL Material Code : SP9025980020 COLLECTING TROUGH WOOD LINER AS PER DRG:4-7-0203-99-03500 MATL:KONGOO WOOD OR EQUIVALEN(HARD WOOD)	Nos.	01 84.000	27/05/2014
5	BHEL Material Code : SP9025980021 COLLECTING TROUGH WOOD LINER AS PER DRG:4-7-0203-99-03501 MATL:KONGOO WOOD OR EQUIVALENT(HARD WOOD)	Nos.	01 84.000	27/05/2014

IMPORTANT NOTE :
 Delivery Terms : "Free Delivery at BHEL-SSTP STORES" is preferable.
 Payment Terms : 100% payment within 45days after receipt and acceptance of materials by BHEL.
 Terms and Conditions of Tender : Please see reverse.
 The Technical Requirements / Specification Details / Quality Requirements/Commercial Terms & Conditions are clearly furnished in the tender. If Deviation(s) is/are not explicitly brought out in the Offer, it will be construed that the Tenderer is complying with the requirement of BHEL in full without any deviation(s).

For and on behalf of
BHARAT HEAVY ELECTRICALS LTD.

PURCHASE EXECUTIVE

 BHARAT HEAVY ELECTRICALS LTD. (A GOVERNMENT OF INDIA UNDERTAKING) SEAMLESS STEEL TUBE PLANT TIRUCHIRAPPALLI - 620 014, TAMIL NADU.	PHONE : 0431-2578480, 2578547, 2578428, 2578406 FAX : 0431-2520464/383	TIN : 33243560005 GST No. 239383 Dated 11.06.1991	PURCHASE ENQUIRY		
	VENDOR CODE 19537	ENQUIRY NUMBER 9431352E			ENQUIRY DATE 21/02/2014
Office Copy		IMPORTANT POINTS : 1. Tender Closing Time - 14.00 Hrs. 2. Tender Opening Time - 15.00 Hrs. 3. Tender should be submitted in a sealed cover, duly indicating enquiry No., Enquiry date & Enquiry Due Date on the cover. 4. Offer(s) received through Courier Services after 14.00 Hrs. on Enquiry Due Date not be considered. 5. Late Tender (s) is/are liable for rejection. 6. Offer(s) shall be valid for 60 days from Enquiry Due Date. 7. Offer(s) in Vendor's Letter-Head shall contain a. Offer No. and Date b. Delivery Period c. Delivery Terms d. Payment Terms e. Excise Duty with Tariff Heading Sales Tax (against form-XVII/Form-C), etc. f. Excise Regn. No. and SSI Regn. No.			
Kindly arrange to submit your COMPETITIVE OFFER for the following item(s). If you are not in a position to submit your Offer, kindly arrange to send your REGRET LETTER . THIS IS ONLY A REQUEST FOR OFFER AND NOT AN ORDER					
Sl.No.	BHEL Material Code and Description	Unit	Requirement		
			Quantity	Delivery	
06	BHEL Material Code : SP9026305100 ----- COLLECTING TROUGH WOOD AS PER DRG:4-7-0263-13-01623 KONGU WOOD	Nos.	01	26.000	27/05/2014
07	BHEL Material Code : SP9026305101 ----- COLLECTING TROUGH WOOD AS PER DRG:4-7-0263-13-01625 KONGU WOOD.	Nos.	01	26.000	27/05/2014
08	BHEL Material Code : SP9026305102 ----- COLLECTING TROUGH WOOD AS PER DRG:4-7-0263-13-01629 KONGU WOOD	Nos.	01	26.000	27/05/2014
09	BHEL Material Code : SP9026305103 ----- COLLECTING TROUGH WOOD AS PER DRG:4-7-0263-13-01627 KONGU WOOD	Nos.	01	26.000	27/05/2014
10	BHEL Material Code : SP9026305104 ----- COLLECTING TROUGH WOOD AS PER DRG:4-7-0263-13-01624 KONGU WOOD	Nos.	01	26.000	27/05/2014
IMPORTANT NOTE : Delivery Terms : "Free Delivery at BHEL S&TP STORES" is preferable. Payment Terms : 100% payment within 45days after receipt and acceptance of materials by BHEL" Terms and Conditions of Tender : Please see reverse. The Technical Requirements / Specification Details / Quality Requirements/Commercial Terms & Conditions are clearly furnished in the Tender. If Deviation(s) is/are not explicitly brought out in the Offer, it will be construed that the Tenderer is complying with the requirement of BHEL in full without any deviation(s)			For and on behalf of BHARAT HEAVY ELECTRICALS LTD.  PURCHASE EXECUTIVE		



BHARAT HEAVY ELECTRICALS LTD.
 (A GOVERNMENT OF INDIA UNDERTAKING)
 SEAMLESS STEEL TUBE PLANT
 TIRUCHIRAPPALLI - 620 014,
 TAMIL NADU.

PHONE : 0431-2578480,
 2578547,2578428,
 2578406
 FAX : 0431-2520464/383

TIN : 33243560005
 CST No. 239383
 Dated 11.06.1991

PURCHASE ENQUIRY

VENDOR CODE 19537	ENQUIRY NUMBER 9431352E	ENQUIRY DATE 21/02/2014	ENQUIRY DUE DATE 14/03/2014	No. OF ITEM 12
----------------------	----------------------------	----------------------------	--------------------------------	-------------------

Office Copy

IMPORTANT POINTS :
 1. Tender Closing Time - 14.00 Hrs.
 2. Tender Opening Time - 15.00 Hrs.
 3. Tender should be submitted in a sealed cover, duly indicating enquiry No., Enquiry Date & Enquiry Due Date on the cover.
 4. Offer(s) received through Courier Services after 14.00 Hrs. on Enquiry Due Date not be considered.
 5. Late Tender (if future) liable for rejection.
 6. Offer(s) shall be valid for 60 days from Enquiry Due Date.
 7. Offer(s) if Vendor's Letter Head shall contain:
 a. Offer No. and Date
 b. Delivery Period
 c. Delivery Terms
 d. Payment Terms
 e. Excise Duty with Tariff Heading Sales Tax (against form-XVIIA form C)- etc.
 f. Excise Regn. No. and SSI Regn. No.

Kindly arrange to submit your **COMPETITIVE OFFER** for the following item(s).
 If you are not in a position to submit your Offer, kindly arrange to send your **REGRET LETTER**.

THIS IS ONLY A REQUEST FOR OFFER AND NOT AN ORDER

Sl.No.	BHEL Material Code and Description	Unit	Requirement		
			Quantity	Delivery	
1	BHEL Material Code : SP9026305105 COLLECTING TROUGH WOOD AS PER DRG:4-7-0263-13-01626 KONGU WOOD	Nos.	01	26.000	27/05/2014
2	BHEL Material Code : SP9026305106 COLLECTING TROUGH WOOD AS PER DRG:4-7-0263-13-01628 KONGU WOOD	Nos.	01	26.000	27/05/2014
<p>Foot Note ::</p> <p>THIS TENDER IS CALLED ON TWO BID SYSTEM. KINDLY REFER THE ANNEX.-A, B & C ATTACHED. CONFIRM THE FOLLOWING TECH/COMMERCIAL POINTS WITHOUT FAIL:</p> <p>1) OUR STD PAYMENT TERMS IS 100 % PYT WITH IN 45 DAYS ON RECEIPT AND ACCEPTANCE OF MATERIALS THRO E-PAYMENT. FORMAT WILL BE SENT ALONG WITH PUR ORDER. 2) PL QUOTE THE RATE ON DOOR DELIVERY BASIS DULY INCLUDING PKG, FORWARDING, FREIGHT AND INSURANCE CHARGES. 3) CONFIRM YR ACCEPTANCE FOR LD AND RISK PURCHASE CLAUSES. 4) TEST CERTIFICATE FOR SEASONING OF WOOD TO BE GIVEN ALONG WITH SUPPLY. 5) PRE-DESPATCH INSPECTION AT SUPPLIER'S PLACE HAS TO BE CARRIED OUT BY SSTP/BHEL EXECUTIVE.</p>					

IMPORTANT NOTE :
 Delivery Terms : "Free Delivery at BHEL-SSTP STORES" is preferable.
 Payment Terms : 100% payment within 45 days after receipt and acceptance of materials by BHEL.
 Terms and Conditions of Tender : Please see reverse.
 The Technical Requirements / Specifications / Details / Quality Requirements / Commercial Terms & Conditions are clearly furnished in the Tender. If Deviation(s) is/are not explicitly brought out in the Offer, it will be construed that the Tenderer is complying with the requirement of BHEL in full without any deviation(s).

For and on behalf of
BHARAT HEAVY ELECTRICALS LTD.

PURCHASE EXECUTIVE

ALL DIMENSIONS ARE IN MM

REV	DATE	ALTERED	<i>M. Marimuthan</i>
01	29.04.13	CHECKED	<i>S. Loganathan</i>
		APPROVED	<i>S. Mohan</i>

Drawing Converted To Acad

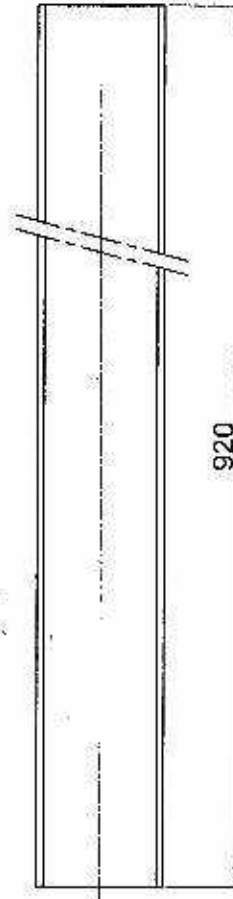
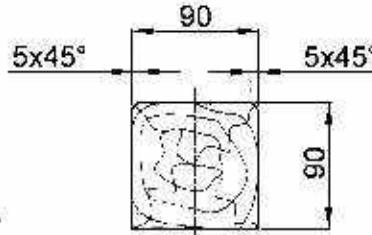

CAUTION: THE INFORMATION ON THIS DOCUMENT IS THE PROPERTY OF BHARAT HEAVY ELECTRICALS LIMITED. IT MUST NOT BE USED DIRECTLY OR INDIRECTLY IN ANY WAY DETRIMENTAL TO THE INTEREST OF THE COMPANY.

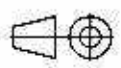
1	920 X 90 X 90									
ITEM NO	DESCRIPTION	DRAWING NO	HARD WOOD		MATL CODE	UNIT WT				
					MATL SPEC	QTY				
EOPT: STRAIGHTENING MACHINE KR75 WITH FACILITIES										
		Bharat Heavy Electricals Ltd SEAMLESS STEEL TUBE PLANT TIRUCHIRAPALLI - 620014			DRN	NAME	SIGNATURE	DATE		
					ECO07		<i>88007</i>	17.12.86		
					CHD	A.AROCKIAM	<i>A. Arockiam</i>	17.12.86		
					APPD	SS.SUNDARAM	<i>SS. Sundaram</i>	17.12.86		
DEPT	GRADE OF UNTOOL. DIM		SCALE	WEIGHT (Kg)	REF TO ASSY DWG NO		ITEM			
SS/TP	<i>Ø/M/F</i> IS:2102		1:5	5.3	0301169-50.300		39			
CODE					REF TO OLD DWG NO					
456					0301169-12.154					
TITLE				CARD CODE	DRAWING NO :			REV		
KRC - WOOD INSERT (TROUGH ASSY - BOTTOM)				U 01	4-7-0136-11-00982			01		

FIRST ANGLE PROJECTION (ALL DIMENSIONS IN MILLIMETRES)

S 27-009

CAUTION THE INFORMATION ON THIS DOCUMENT IS THE PROPERTY OF BHARAT HEAVY ELECTRICALS LTD. IT MUST NOT BE USED DIRECTLY OR INDIRECTLY IN ANY WAY DETRIMENTAL TO THE INTEREST OF THE COMPANY.

REV	DATE	ALTERED
01	18/8/90	CHD & APPD. J. Jeyaraj

HOLE PITCH 675 & 525 WERE 600 & 600 RESPECTIVELY.

2

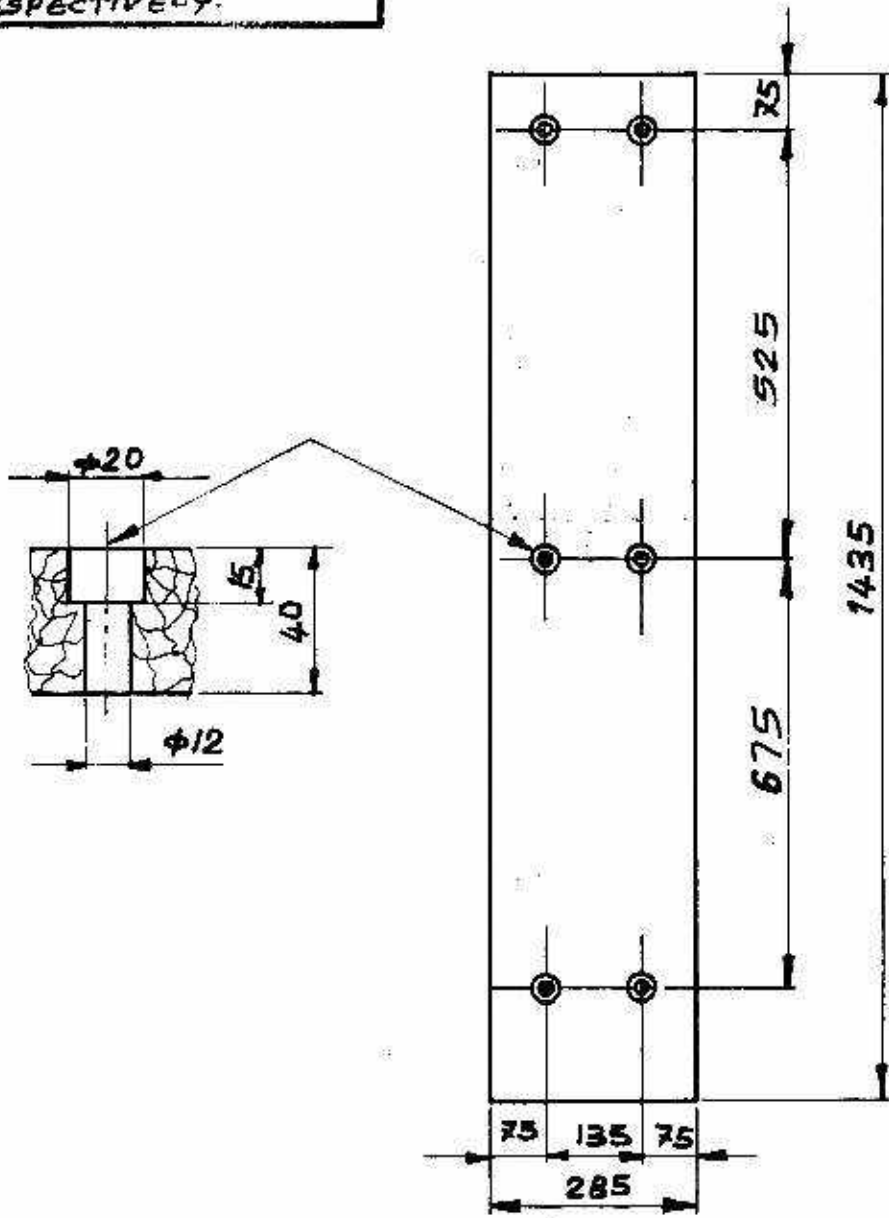

		HARD WOOD	
ITEM NO.	DESCRIPTION	MATL CODE	UNIT WT
		MATL SPEC	QTY

EAPT: BOT DRAW BENCH



Bharat Heavy Electricals Ltd.,
SEAMLESS STEEL TUBE PLANT
TIRUCHIRAPALLI - 620 014

DRN	NAME	SIGN	DATE
	S MOHAN RAJ	<i>[Signature]</i>	15.07.90
CHD			
APPD		<i>[Signature]</i>	21.1.93

DEPT	GRADE OF UNTOL DIM	SCALE	WEIGHT (KG)	REF TO ABBY/OLD DRG	ITEM NO.
	C/M/F	1:10		0.25 2070 = 37000	116
TITLE	CARD CODE	DRAWING NO.	REV		
WOOD LINER (HINGED TABLE)	U 01	4-7-0111-03-04161	01		

ALL DIMENSIONS ARE IN MM

REV	DATE	ALTERED	<i>M. Marayappan</i>
01	29.04.13	CHECKED	<i>B. Loganathan</i>
		APPROVED	<i>F. Mohan</i>

Drawing Converted To Acad

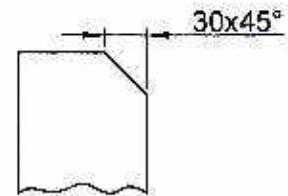
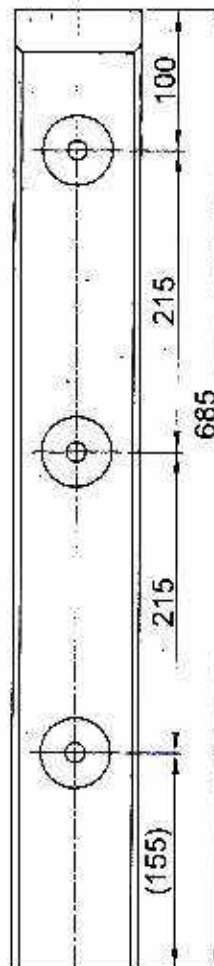
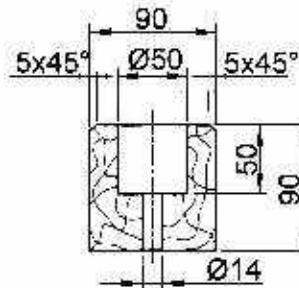

Note : 2 nos for 1 trough

CAUTION: THE INFORMATION ON THIS DOCUMENT IS THE PROPERTY OF BHARAT HEAVY ELECTRICALS LIMITED. IT MUST NOT BE USED DIRECTLY OR INDIRECTLY IN ANY WAY DETRIMENTAL TO THE INTEREST OF THE COMPANY.

1	685 X 90 X 90								
ITEM NO	DESCRIPTION	DRAWING NO	HARD WOOD		MATL CODE		UNIT WT		
					MATL SPEC		QTY		
EQPT: STRAIGHTENING MACHINE KR75 WITH FACILITIES									
		Bharat Heavy Electricals Ltd SEAMLESS STEEL TUBE PLANT TIRUCHIRAPALLI - 620014			DRN	EC007	NAME	SIGNATURE	DATE
DEPT		GRADE OF UNTOL DIM	SCALE	WEIGHT (Kg)	REF TO ASSY DWG NO	ITEM			
SSTP		<i>C/M/F</i>	1:5	3.9	0301169-50.300	38			
CODE		IS: 2102			REF TO OLD DWG NO				
455					0301169-12.155				
TITLE				CARD CODE	DRAWING NO :				REV
KRC - WOOD INSERT (TROUGH ASSY - SIDE)				U 01	4-7-0136-11-00983				01

FIRST ANGLE PROJECTION (ALL DIMENSIONS IN MILLIMETERS)

S 27-009

CAUTION: The information on this document is the property of BHARAT HEAVY ELECTRICALS LTD. It must not be used directly or indirectly in any way detrimental to the interest of the Company.

REV 01	DATE	ALTERED
		CHECKED
ZONE		

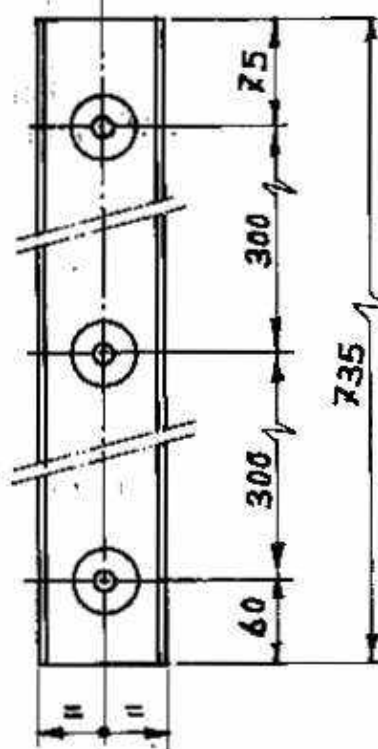
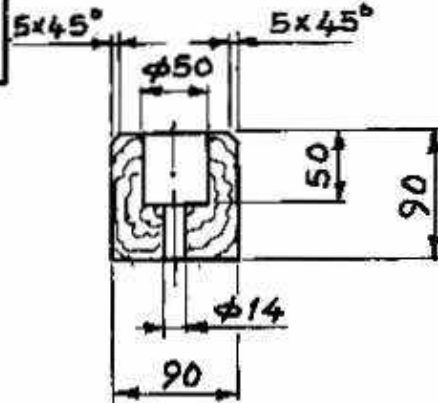

		HARD WOOD KONGU OR EQUIVALENT.	
ITEM NO.	DESCRIPTION	MATL CODE	UNIT WT.
		MATL SPEC	QTY

EQPT: DOUBLE END CUT-OFF MACHINE WITH FACILITIES.

<p>Bharat Heavy Electricals Ltd. SEAMLESS STEEL TUBE PLANT TIRUCHIRAPALLI-620 014</p>	DRN	NAME	SIGN	DATE
	CHD	S. MOHAN RAJ	S. Mohan Raj	21-07-87
	APPD	P. RAJESH	P. Rajesh	21-07-87

DEPT	Grade of Unit of Dim	SCALE	WEIGHT (Kg)	REF TO ASSY/DWG ORC	Item NO.
CODE	C/M/E	1:5	4.2	0301 169-12.108	

TITLE	CARD CODE	DRAWING NO.	REV
WOOD INSERT	U 01	4-7-0203-99-03500	00

FIRST ANGLE PROJECTION (ALL DIMENSIONS IN MILLIMETERS)

S 27-909

CAUTION: The information on this document is the property of BHARAT HEAVY ELECTRICALS LTD. It must not be used directly or indirectly in any way detrimental to the interest of the Company.

REV	DATE	ALTERED
01		CHECKED
/ONE		

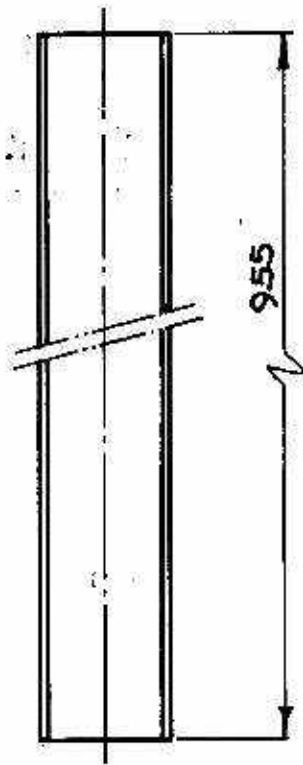
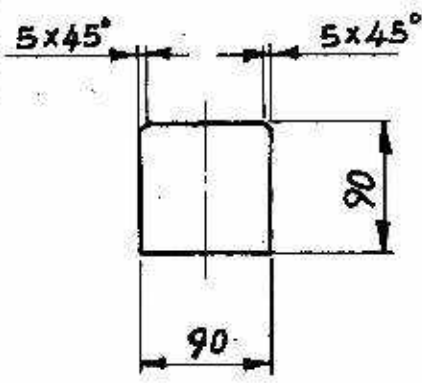

		HARD WOOD KONGOO OR EQUIVALENT.	
ITEM NO.	DESCRIPTION	MATL CODE	UNIT WT.
		MATL SPEC	QTY

EQPT: DOUBLE END CUT-OFF MACHINE WITH FACILITIES.

<p>Bharat Heavy Electricals Ltd. SEAMLESS STEEL TUBE PLANT TIRUCHIRAPALLI-620 014</p>	DRN	NAME	SIGN	DATE
	CHD	S. MOHAN RAJ	S. Mohan Raj	21-07-87
	APPD	A. ARUNKUMAR	J. Jagan	21-7-87
			S. Shanmugan	21-07-87

DEPT	Grade of Untol Dim		SCALE	WEIGHT (Kg)	REF TO ASSY/OLD DRG	Item NO.
CODE	C/M/F		1:5	5.4	0301 169-12.109	

TITLE	CARD CODE	DRAWING NO.	REV
WOOD INSERT	U 01	4-2-0203-99-03501	00

FIRST ANGLE PROJECTION (ALL DIMENSIONS IN MILLIMETRES)

05-248/B

CAUTION THE INFORMATION ON THIS DOCUMENT IS THE PROPERTY OF BHARAT HEAVY ELECTRICALS LTD. IT MUST NOT BE USED DIRECTLY OR INDIRECTLY IN ANY WAY DETRIMENTAL TO THE INTEREST OF THE COMPANY.

REV 01	DATE 28-7-99	ALTERED : P. Senthil
		CHECKED : J. Jagan
ZONE		APPROVED : J. Jagan
CHAMFER 8x45° AT BOTTOM ALSO ADDED		

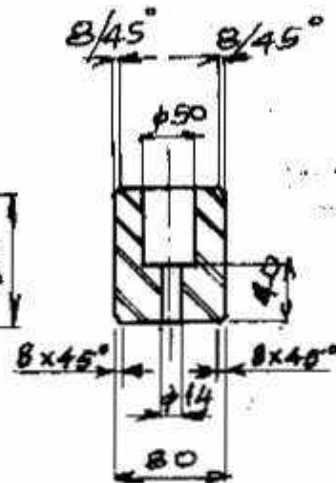
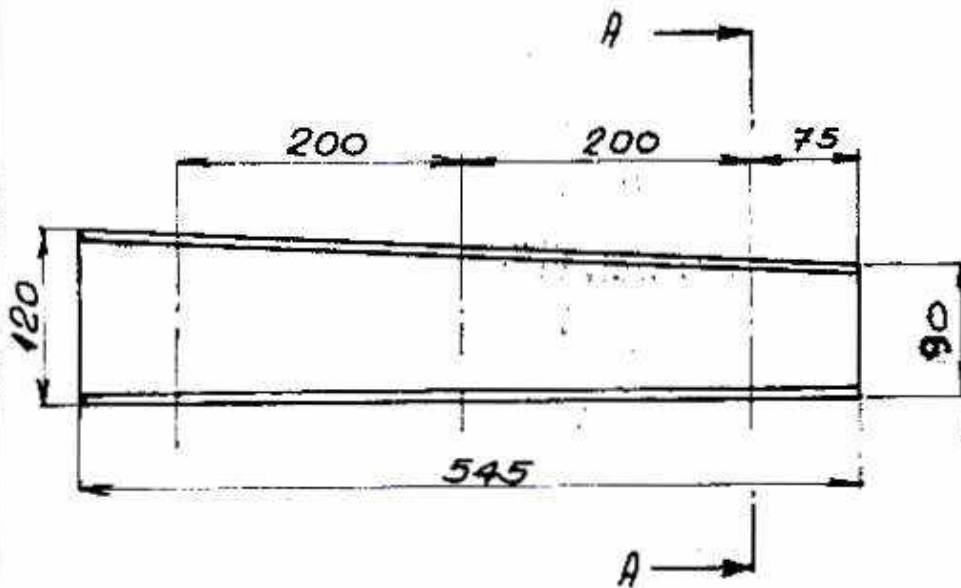

SECTION-AA



		HARD WOOD	
		KONGAD(012) EQUI.	
ITEM NO.	DESCRIPTION	MATL CODE	UNIT WT
		MATL SPEC	QTY
EQPT: SINGLE HEAD CUT-OFF M/C WITH FACILITIES			

	Bharat Heavy Electricals Ltd., SEAMLESS STEEL TUBE PLANT TIRUCHIRAPALLI-620 014		DRN	NAME S. Senthil	SIGN [Signature]	DATE
	DEPT	GRADE OF UNTOL. DIM C/M/F	CHD	A-ARICKIAM	J. Jagan	15.12.92
	CODE		APPD	[Signature]	[Signature]	15.12.92
TITLE		SCALE	WEIGHT (kg)	REF TO ASSY/OLD DRG		ITEM NO.
LINER WOOD COLLECTING TROUGH		I	2.9	SSTP-1M-469		
		CARD CODE	DRAWING NO.			REV.
		U 01	4-7-0263-13-01623			01

FIRST ANGLE PROJECTION (ALL DIMENSIONS IN MILLIMETRES)

05-249

CAUTION THE INFORMATION ON THIS DOCUMENT IS THE PROPERTY OF BHARAT HEAVY ELECTRICALS LTD. IT MUST NOT BE USED DIRECTLY OR INDIRECTLY IN ANY WAY DETRIMENTAL TO THE INTEREST OF THE COMPANY.

REV 01	DATE	ALTERED	J. Shrinani
	28-7-92	CHECKED	J. Shrinani
ZONE		APPROVED:	J. Shrinani
CHAMFER 8x45° ADDED AT BOTTOM ALSO.			

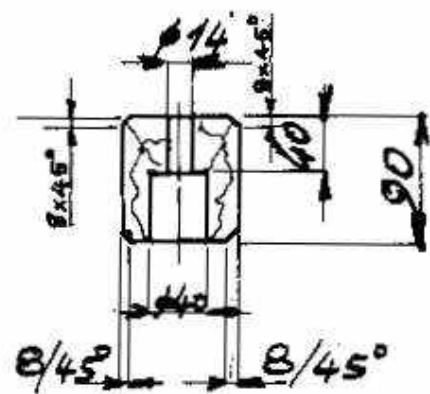
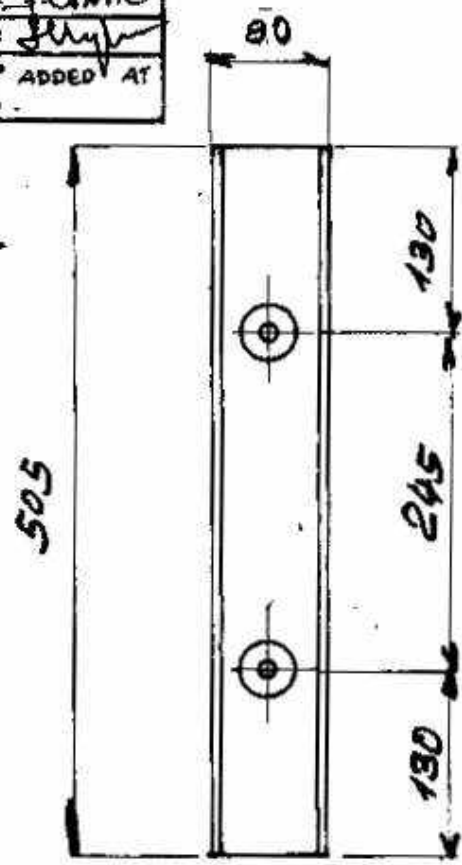

ITEM NO.	DESCRIPTION	MATL CODE	UNIT WT
		MATL SPEC	QTY
EQPT: SINGLE HEAD CUT-OFF M/C WITH FACILITIES			
		KONGOO (R) EQUI.	
		HARD WOOD	



Bharat Heavy Electricals Ltd.,
SEAMLESS STEEL TUBE PLANT
TIRUCHIRAPALLI-620 014

DRN	NAME	SIGN	DATE
CHD	A. ARUNKANN	J. SHRINANI	15-12-82
APPD		J. SHRINANI	15-12-82

DEPT	GRADE OF UNTOL. DIM C/M/F	SCALE	WEIGHT (KG)	REF TO ASSY/OLD DRG	ITEM NO.
CODE		N.T.S	2.36	S.S.T.P 1M-471.	
TITLE			CARD CODE	DRAWING NO.	REV.
LINER WOOD COLLECTING TROUGH			U 01	4-7-0263-13-01625	01

FIRST ANGLE PROJECTION (ALL DIMENSIONS IN MILLIMETRES)

05 249 B

CAUTION THE INFORMATION ON THIS DOCUMENT IS THE PROPERTY OF BHARAT HEAVY ELECTRICALS LTD. IT MUST NOT BE USED DIRECTLY OR INDIRECTLY IN ANY WAY DETRIMENTAL TO THE INTEREST OF THE COMPANY.

REV 01	DATE	ALTERED
	28-7-82	J. Chryl
		CHECKED
		A. Arackiam
ZONE	APPROVED	
	CHAMFER 8x45° ADDED AT BOTTOM ALSO	

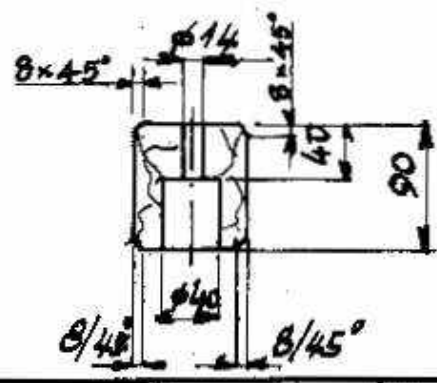
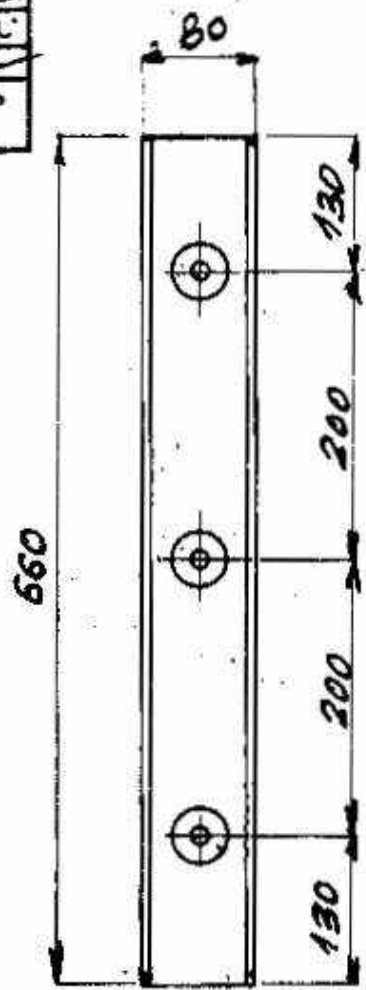

ITEM NO.	DESCRIPTION	KONGOO (N) ERUI	
		HARD WOOD	
		MATL CODE	UNIT WT
		MATL SPEC	QTY

EQPT: SINGLE HEAD CUT-OFF M/C WITH FACILITIES



Bharat Heavy Electricals Ltd.,
SEAMLESS STEEL TUBE PLANT
TIRUCHIRAPALLI-620 014

DRN	NAME	SIGN	DATE
	Shankar	[Signature]	
CHD	A. ARACKIAM	J. Chryl	10.12.82
APPD		[Signature]	15.12.82

DEPT	GRADE OF UNTOL. DIM	SCALE	WEIGHT (kg)	REF TO ASSY/OLD DRG	ITEM NO.
CODE	C/M/F	NTS	3	S.S.T.P - 1M - 475	
TITLE			CARD CODE	DRAWING NO.	REV
LINER WOOD			U 01	4-7-0263-13-01629	01
COLLECTING TROUGH					

FIRST ANGLE PROJECTION (ALL DIMENSIONS IN MILLIMETRES)

CAUTION THE INFORMATION ON THIS DOCUMENT IS THE PROPERTY OF BHARAT HEAVY ELECTRICALS LTD. IT MUST NOT BE USED DIRECTLY OR INDIRECTLY IN ANY WAY DETRIMENTAL TO THE INTEREST OF THE COMPANY.

REV 01	DATE 6-5-78	ALTERED: A. N. Srinivas
		CHECKED: A. Srinivas
ZONE		APPROVED: A. Srinivas
DIMENSIONS 180 AND 770 WERE 130 AND 670		
REV 02	DATE 28-7-80	ALTERED: J. Srinivas
		CHECKED: A. Srinivas
ZONE		APPROVED: J. Srinivas
CHAMFER 8x45° AT BOTTOM ALSO ADDED.		

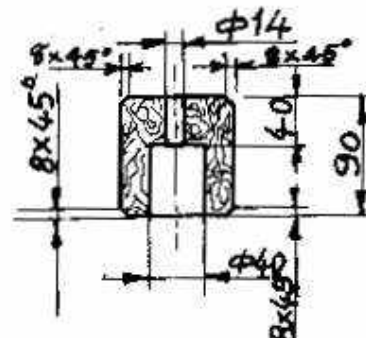
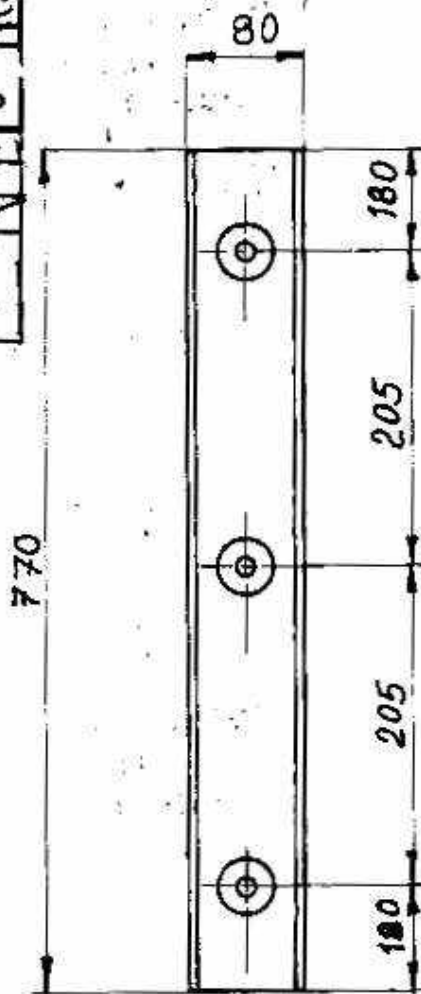

ITEM NO.	DESCRIPTION	KONGOD (14) ERUI	
		HARD WOOD	
		MATL CODE	UNIT WT
		MATL SPEC	QTY
EQPT: SINGLE HEAD CUT-OFF M/C WITH FACILITIES			

	Bharat Heavy Electricals Ltd., SEAMLESS STEEL TUBE PLANT TIRUCHIRAPALLI-820 014	DRW	NAME S. MOHAN	SIGN S. Mohan	DATE 13-12-82
		CHO	S. S. N. KUNDRU	S. S. N. Kundru	15-12-82
		APPD		S. Srinivas	15-12-82

DEPT	GRADE OF UNTOOL DIM C/M/F	SCALE	WEIGHT (KG)	REF TO ASSY/OLD DRG	ITEM NO.
		1	3.670	SSTP-1M-473	
TITLE			CARD CODE	DRAWING NO.	REV
LINER WOOD COLLECTING TROUGH			U 01	4-7-0263 13-01627	02

FIRST ANGLE PROJECTION (ALL DIMENSIONS IN MILLIMETRES)

05 249 / B

CAUTION THE INFORMATION ON THIS DOCUMENT IS THE PROPERTY OF BHARAT HEAVY ELECTRICALS LTD. IT MUST NOT BE USED DIRECTLY OR INDIRECTLY IN ANY WAY DETRIMENTAL TO THE INTEREST OF THE COMPANY.

REV 01	DATE 18/12/82	ALTERED <i>A. Channu</i>	REV 02	DATE	ALTD 1
		CHECKED <i>A. Channu</i>			CHKD :
ZONE	APPROVED: <i>[Signature]</i>				APPD :
DIMENSIONS R 490 AND R 580 WERE R 390 AND 480 RESPECTIVELY. CHAMFER 8x45° AT BOTTOM ALSO ADDED.					

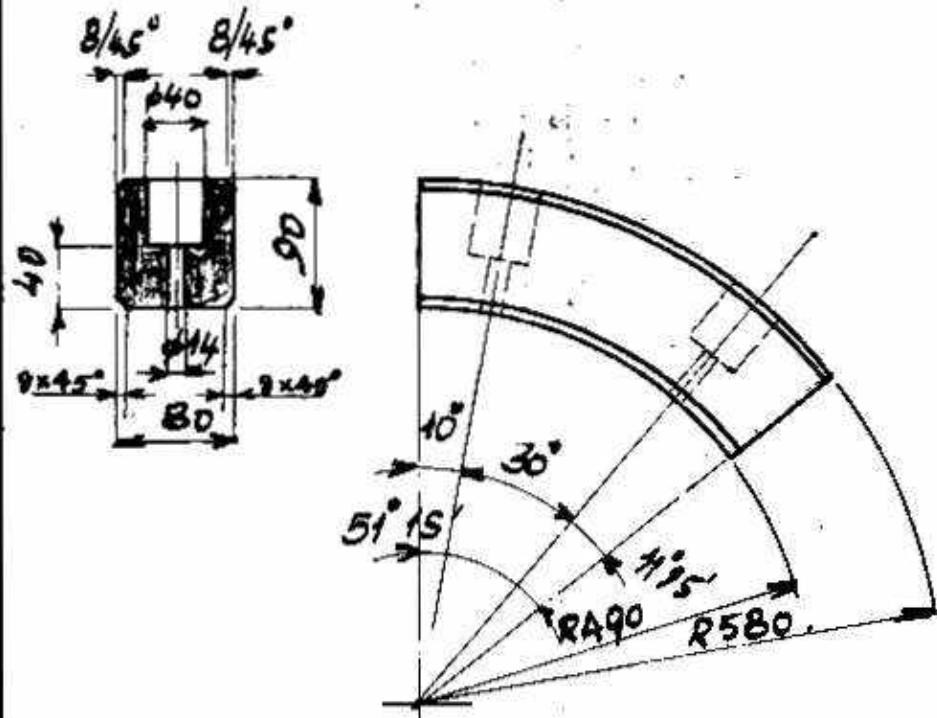

		KONGOO (OR) ERUI.	
		HARD WOOD	
ITEM NO.	DESCRIPTION	MATL CODE	UNIT WT
		MATL SPEC	QTY

EQPT: SINGLE HEAD CUT OFF M/C WITH FACILITIES

Bharat Heavy Electricals Ltd., SEAMLESS STEEL TUBE PLANT TIRUCHIRAPALLI-620 014		DRN	NAME <i>[Signature]</i>	SIGN <i>[Signature]</i>	DATE
DEPT	GRADE OF UNTO. DIM C/MIF	CHD	A.A. ROCKIA	A. Channu	15-12-82
CODE		APPD			15-12-82
DEPT	SCALE <i>I</i>	WEIGHT (kg)	REF TO ASSY/OLD DRG	ITEM NO.	
		1.8	SSTP-1M-470		
TITLE		CARD CODE	DRAWING NO.		REV
LINER WOOD COLLECTING TROUGH		U 01	4-7-0263-13-01624		01

FIRST ANGLE PROJECTION (ALL DIMENSIONS IN MILLIMETRES)

05 249, B

CAUTION THE INFORMATION ON THIS DOCUMENT IS THE PROPERTY OF BHARAT HEAVY ELECTRICALS LTD. IT MUST NOT BE USED DIRECTLY OR INDIRECTLY IN ANY WAY DETRIMENTAL TO THE INTEREST OF THE COMPANY.

REV	DATE	ALTERED	J. Shankar
01	28-7-82	CHECKED	J. Shankar
ZONE	APPROVED: [Signature]		
CHAMFER 8x45° ADDED AT BOTTOM ALSO			

~

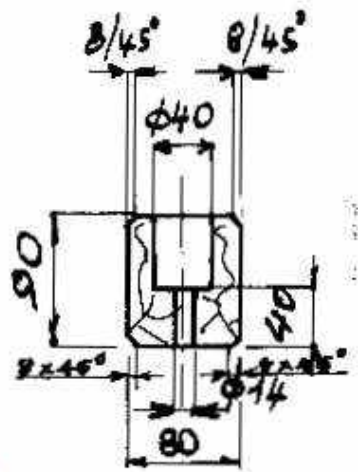
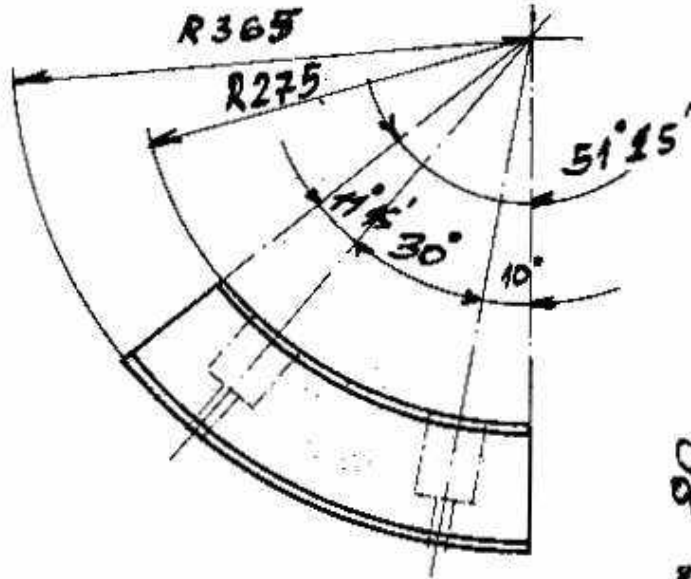

ITEM NO.	DESCRIPTION	KON GOOD (R) EQUI.	
		HARD WOOD	
		MATL CODE	UNIT WT
		MATL SPEC	QTY

EQPT: SINGLE HEAD CUT-OFF M/C WITH FACILITIES

 Bharat Heavy Electricals Ltd., SEAMLESS STEEL TUBE PLANT TIRUCHIRAPALLI-620 014	DRN	NAME	SIGN	DATE	
	CHD	A. ARACKIAM	J. SHANKAR	15-12-82	
	APPO		[Signature]	15-12-82	
DEPT	GRADE OF UNTOOL. DIM	SCALE	WEIGHT (kg)	REF TO ASSY/OLD ORG	ITEM NO.
CODE	C/MIF	I	1.3	SSTP-1M-472	
TITLE			CARD CODE	DRAWING NO.	REV.
LINER WOOD COLLECTING TROUGH			U 01	4-7-0263 13-01626 01	

FIRST ANGLE PROJECTION (ALL DIMENSIONS IN MILLIMETRES)

05-249/B

CAUTION THE INFORMATION ON THIS DOCUMENT IS THE PROPERTY OF BHARAT HEAVY ELECTRICALS LTD. IT MUST NOT BE USED DIRECTLY OR INDIRECTLY IN ANY WAY DETRIMENTAL TO THE INTEREST OF THE COMPANY.

REV 01	DATE 28-7-98	ALTERED : P. Srinivas
		CHECKED : J. Umrigar
ZONE		APPROVED : [Signature]
CHAMFER 8x45° ADDED AT BOTTOM ALSO.		

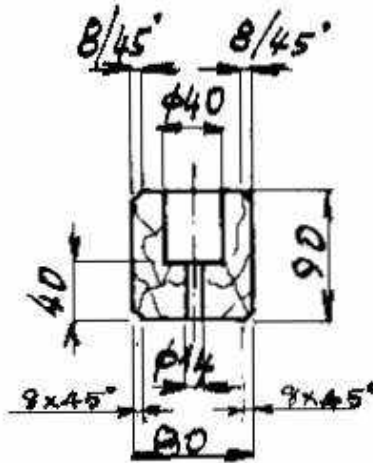
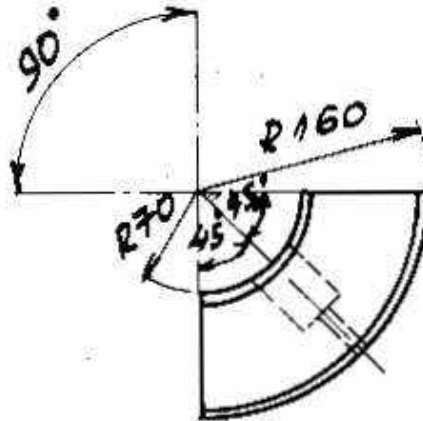

		KONGOO (R) EQUI.	
		HARD WOOD	
ITEM NO.	DESCRIPTION	MATL CODE	UNIT WT
		MATL SPEC	QTY

EQPT: SINGLE HEAD CUT-OFF M/C WITH FACILITIES



Bharat Heavy Electricals Ltd.,
SEAMLESS STEEL TUBE PLANT
TIRUCHIRAPALLI-620 014

DRN	NAME S. Prasad	SIGN	DATE
CHD	A. ARICKAM	J. Umrigar	15-12-82
APPD		[Signature]	15-12-82

DEPT	GRADE OF UNTOI. DIM C/M/F	SCALE NTS	WEIGHT (kg) 0.85	REF TO ASSY/OLD DRG 35TP-1M-474	ITEM NO.
------	------------------------------	--------------	---------------------	------------------------------------	----------

TITLE LINER WOOD	CARD CODE U 01	DRAWING NO. 4-7-0263-13-01628	REV 01
----------------------------	-------------------	---	-----------

Certificate by Chartered Accountant

This is to Certify that M/S,
(hereinafter referred to as 'company') having its registered office at
..... is registered under MSMED Act 2006, (Entrepreneur
MeMemorandum No (Part—II)..... dtd:.....,
Category:..... (Micro/Small)). (Copy enclosed).

Further verified from the Books of Accounts that the investment of the company as on
date as per MSMED Act 2006 is as follows:

1. **For Manufacturing Enterprises: Investment in plant and machinery** (i.e. original cost
excluding land and building and the items specified by the Ministry of Small Scale Industries vide its
notification No.5.0.1722(E) dated October 5, 2006:
Rs.Lacs
2. **For Service Enterprises: Investment in equipment** (original cost excluding land and building and
furniture, fittings and other items not directly related to the service rendered or as may be notified under the MSMED
Act, 2006:
Rs.Lacs

The above investment of Rs..... Lacs is within permissible limit of
RsLacs for Micro / Small (~~Strike off which is not applicable~~)
Category under MSMED Act 2006.

Date:

(Signature)

Name -

Membership number -

Seal of Chartered Accountant

Annexure-A

Important Note to Tenderers - for TWO BID system (including REVERSE AUCTION)

(Page No. 1 of 4)

1. This Tender is floated on TWO-BID System.
 - A. Tenderers are requested to submit their Offers in TWO-BID basis, viz.
 - a. Part I .. Technical and Un-Priced Commercial Bid
 - b. Part II .. Price Bid
 - B Both the above Bids are to be submitted (or to be made available) before 14.00 hours (Indian Time) on Tender Due Date, as detailed under Para 3 below. **Tenders received after 14.00 Hrs. on the Tender Due Date, shall not be taken into consideration, irrespective of the mode of dispatch.**
2. Above Bids (Part I and Part II) are to be submitted in sealed-covers as detailed below:

A. Technical and Un-Priced Commercial Bid :

- a. Shall contain complete Scope of Supply with all Technical details, Specifications, Delivery Schedule, Delivery Terms, Payment Terms, Offer Validity, Taxes & Duties and other Commercial Terms & Conditions.
(Also please refer Clause No. 5 – General).
- b. Price columns are to be strictly filled-in only as ‘QUOTED’:

Enq. Sl. No.	BHEL Matl. Code / Description of Material.	Quantity with Unit Name	Unit Rate Rs.	Total Price Rs.
..	QUOTED	QUOTED
- c. Shall contain Point-wise confirmation for all Enquiry Clause Nos., TDC Clause Nos., and other attachments, if any.
- d. If any deviation is taken on Technical and / or Commercial points, the same shall be clearly highlighted in the Offer with Enquiry Clause No(s). and its attachments. Otherwise, it shall be construed by BHEL that the Tenderer is complying with all Enquiry Clauses in full.
- e. Any request for modification / change of Technical / Commercial points shall be entertained only before they are frozen.

B. Price Bid:

- a. Shall contain following details **only**:

Enq. Sl. No.	BHEL Matl. Code / Description of Material.	Quantity with Unit Name	Unit Rate Rs.	Total Price Rs.

- b. Wherever required / possible, Break-up-Price details are to be furnished.
- c. This Bid shall NOT contain any Technical and/or Commercial Conditions.
(If indicated, such terms shall not be taken into consideration).

Annexure-A

Important Note to Tenderers - for TWO BID system (including REVERSE AUCTION)

(Page No. 2 of 4)

3. **Details for submitting the Offer:**

A. **Cover No.1 – Technical and Un-Priced Commercial Bid :**

- a. Put the Technical & Un-Priced Commercial Bid inside Cover No.1 seal it.
- b. Mark Cover No.1 :
“Part-I -- TECHNICAL and UN-PRICED COMMERCIAL BID”
Tender No., Tender Date, Tender Due date, Address of Tenderer.

B. **Cover No.2 -- Price Bid :**

- a. Put the Price Bid inside Cover No.2 and seal it.
- b. Mark Cover No.2 :
“Part-II - PRICE BID”
Tender No., Tender Date, Tender Due date, Address of Tenderer.

C. **Cover No.3 -- Techno-Commercial Bid & Price Bid :**

- a. Put Cover No. 1 and 2 inside Cover No.3 and seal it.
- b. Mark Cover No. 3, with Tender No., Tender Date, Tender Due date, Address of Tenderer.
- c. Address the Cover No.3, to ::
Purchase Executive,
BHEL/SSTP,
Tiruchirapalli-620014, INDIA.

4. **Tender Opening:**

- A. On the Tender Due Date, Technical and Un-Priced Commercial Bid (Ref: 1.A.a. and 3.A. above), shall alone be opened, at the pre-fixed time, in presence of Responded Tenderers / their Authorized Representative, who may like to be present for Tender opening.
- B. Clarifications / Confirmations, if any, required by BHEL for Technical / Commercial evaluation, shall be sought from Bidders before opening the Price Bid.
- C. Price Bid of Technically suitable Bidders alone shall be opened, on a pre-determined date and time, in presence of the Responded Tenderers / their Authorized Representative, who may like to be present for such opening.

5. **General:**

- A. Incomplete Offers shall be liable for rejection.
- B. Fixed Price:
Bidder shall quote only Fixed Rate / Price and not subject to any escalation whatsoever during the period of Bid Validity and execution of Purchase Order. Any Bid with adjustable or price variation clause shall be treated as ‘Non-Responsive’ and liable for rejection. Prices shall be written both in numbers and words. In the event of any difference, the price in words shall be valid and binding. Unit Rate shall only be considered as correct and valid, which shall be taken for further consideration.

Annexure-A

Important Note to Tenderers - for TWO BID system (including REVERSE AUCTION)

(Page No. 3 of 4)

C. Taxes and Duties:

All Taxes / Duties, if any, payable extra over and above the quoted rate, shall be specifically indicated in the Un-Priced Bid, failing which the quoted rates shall be considered as '**all inclusive**'.

Offer shall carry clear details of Excise Tariff Heading No. and applicable Rate of ED / ST (along with Rate of Cess, if any).

D. Validity of Offer:

Offer shall be kept valid for acceptance for a period of 60 days (sixty days) from the date of opening of the Technical & Un-Priced Bid.

E. Terms of Payment:

Refer annexure B.

F. Liquidated Damages, Risk Purchase and Warranty:

Refer annexure B

G. Evaluation of the Offers shall be on the basis of 'To-Door Cost at SSTP' (NET Cash outflow to BHEL)

H. BHEL reserves the right:

a. to increase or decrease the tendered quantity(s) and split such quantities, for all or part of the Enquiry items, among more than one Tenderer based on commitments, requirements and capability of the Vendor(s), and finalise the Tender accordingly.

b. ~~to finalise order on Public Sector Enterprises under Price Preference facilities as admissible in the existing policy.~~

c. to reject any Tender due to unsatisfactory past performance in the execution of a Contract.

d. **to resort for a REVERSE AUCTION (RA), i.e. ON-LINE BIDDING THROUGH INTERNET**, instead of opening the Sealed Price Bid submitted earlier, which shall be decided after evaluation of **TECHNICAL and UN-PRICED COMMERCIAL BID**

I. **In case BHEL decides NOT to resort for RA, Price Bids and Price-Impacts, if any, already submitted by Bidder and available with BHEL, shall be opened, as detailed under Point 4 above.**

J. **Information and General Terms and Conditions governing RA, are detailed below**

Against this enquiry for the subject item/ system with detailed scope of supply as per enquiry specifications, BHEL may resort to "REVERSE AUCTION PROCEDURE" i.e., ON LINE BIDDING (THROUGH A SERVICE PROVIDER). The philosophy followed for reverse auction shall be English Reverse (No ties).

Annexure-A

Important Note to Tenderers - for TWO BID system (including REVERSE AUCTION)

(Page No. 4 of 4)

1. For the proposed reverse auction, technically and commercially acceptable bidders only shall be eligible to participate.
2. Those bidders who have given their acceptance for Reverse Auction (quoted against this tender enquiry) will have to necessarily submit, online sealed bid in the Reverse Auction. Non-submission of „online sealed bid“ by the bidder for any of the eligible items for which techno commercially qualified, will be considered as tampering of the tender process and will invite action by BHEL as per extant guidelines in vogue.
3. BHEL will engage the services of a service provider who will provide all necessary training and assistance before commencement of on line bidding on internet.
4. In case of reverse auction, BHEL will inform the bidders the details of Service Provider to enable them to contact & get trained.
5. Business rules like event date, time, bid decrement, extension etc. also will be communicated through service provider for compliance.
6. Bidders have to fax the Compliance form (annexure IV) before start of Reverse auction. Without this, the bidder will not be eligible to participate in the event.
7. In line with the NIT terms, BHEL will provide the calculation sheet (e.g., EXCEL sheet) which will help to arrive at “Total Cost to BHEL” like Packing & forwarding charges, Taxes and Duties, Freight charges, Insurance, Service Tax for Services and loading factors (for noncompliance to BHEL standard Commercial terms & conditions) for each of the bidder to enable them to fill-in the price and keep it ready for keying in during the Auction.
8. Reverse auction will be conducted on scheduled date & time.
9. At the end of Reverse Auction event, the lowest bidder value will be known on auction portal.
10. The lowest bidder has to fax/e-mail the duly signed and filled-in prescribed format for price breakup including that of line items, if required, (Annexure VII) as provided on case-to-case basis to Service provider within two working days of Auction without fail.
11. In case BHEL decides not to go for Reverse Auction procedure for this tender enquiry, the Price bids and price impacts, if any, already submitted and available with BHEL shall be opened as per BHEL s standard practice.
12. Bidders shall be required to read the “Terms and Conditions” section of the auctions site of Service provider, using the Login IDs and passwords given to them by the service provider before reverse auction event. Bidders should acquaint themselves of the „Business Rules of Reverse Auction“, which will be communicated before the Reverse Auction.
13. If the Bidder or any of his representatives are found to be involved in Price manipulation/ cartel formation of any kind, directly or indirectly by communicating with other bidders, action as *per extant BHEL guidelines*, shall be initiated by BHEL and the results of the RA scrapped/ aborted.
14. The Bidder shall not divulge either his Bids or any other exclusive details of BHEL to any other party.
15. In case BHEL decides to go for reverse auction, the H1 bidder (whose quote is highest in online sealed bid) may not be allowed to participate in further RA process.

KINDLY PROVIDE FOLLOWING INFORMATION, IN CASE OF REVERSE AUCTION TO BE CONDUCTED

NAME OF THE PERSON:

MOBILE NO. :

LAND LINE NO. :

FAX NO. :

EMAIL ID :

.....oo0oo.....

Annexure – B.
PAYMENT TERMS

Vendor Code:	Vendor Name:	
Tender No.:	Tender Date:	Tender Due Date:

IMPORTANT NOTE TO SUPPLIERS:

If materials are receivable at Stores/Trichy <u>without PBG</u>	Payment term is 100% direct payment after 45 days from the date of receipt and acceptance of materials.
If materials are receivable at Stores/Trichy <u>with PBG</u>	Payment term is 100% direct payment after 45 days from the date of receipt and acceptance of materials and against 10% PBG valid for the warranty period.
Any deviation in the above payment term will attract loading as mentioned below. “Base rate of SBI (as applicable on the date of Techno-commercial bid opening) + 6% will be loaded for the period of relaxation sought by bidders.	

Payment through bank	Payment through Bank is not preferred. In case of Payment through Bank is opted by Supplier, BHEL prefers documents submission through bank with copy of LR and door delivery of Goods to Site/Stores with Consignee copy attached. In this case Loading will be 3% on the offered value.
	Offers of indigenous Suppliers with payment terms as LC/Advance Payment are liable for rejection.

Liquidated Damages / Penalty

- a. Liquidated damages shall be 0.5% of the total order value per week or part thereof subject to a maximum of 10% of the total order value.
- b. For staggered delivery schedule, LD shall be 0.5% of the undelivered portion per week of the delay or part thereof subject to a maximum of 10% of the total order value.
- c. Any deviation from the above LD clause, loading will be applied to the extent to which it is not agreed by the bidder (at offered value).

Guarantee / Warranty Period

Normally No deviation permitted and the deviated offers are liable for rejection.

Performance Bank Guarantee

Normally No deviation permitted and the deviated offers are liable for rejection.

BHEL will consider the ranking after the loading is applied as referred above wherever deviations are observed.

Annexure – C.
Commercial Conditions

Vendor Code:	Vendor Name:		
Tender No.:	Tender Date:	Tender Due Date:	

Sl. No.	Commercial Terms	Accepted	If Not accepted, give details
C 1.	<u>Delivery Terms:</u> Free delivery at BHEL/SSTP Stores. (including Packing, Forwarding, Freight and Insurance charges)		
C 2.	<u>Payment term :</u> 100% direct payment after 45 days from the date of receipt and acceptance of materials		
C 3.	Liquidated damages @ ½% per week subject to maximum of 10% of the order value shall be applicable for delay in deliveries		
C 4.	<u>Delivery:</u>	<u>indicate no. of weeks</u>	
C 5.	<u>Validity of Offer</u> - 60 Days from the Date of Tender Opening.		
C 6.	<u>Guarantee certificate:</u> shall cover total period of 18 months from date of dispatch or 12 months from the date of actual usage of the material whichever is earlier		
C 7.	<u>Erection and Commissioning(if applicable)</u> Erection / commissioning charges if any has to be mentioned in the offer or else it will be assumed that Erection/ commissioning will be done at free of cost	<u>Pl indicate applicability</u>	
Remarks, if any (attach additional sheet, if required) :			

Sl. No.	Commercial Terms	Vendor to fill in
C 8.	a. Excise Duty Tariff Heading	
	b. Excise Duty (%)	
	c. CESS on ED (%)	
	d. Total of ED and CESS (%)	
C 9.	a. TVNAT (%)	
	b. CST (%)	
C 10.	Other Cost (if any) - % (or) Rs.	
C 11.	Are you Micro/Small/Medium Industry?	Yes / No.
	If YES, please furnish MSM Regn. No. along with a copy of MSM Certificate	MSM No. : MSM Certificate Enclosed : Yes / No

Signature with Date	Seal