



Bharat Heavy Electricals Limited
(Seamless steel Tube Plant)
Tiruchirappalli – 620014, TAMIL NADU, INDIA

TITLE: SUPPLY OF Gaskets as per Drg. & Non Metallic Asbestos Gaskets	Phone: +91 431 257 8428 Email : rbmurugan@bheltry.co.in Web : www.bhel.com
---	---

Enquiry Number: 9440575E	Date: 02.05.2014	Due date for submission of application: 23.05.2014
---------------------------------	-------------------------	---

BHEL/SSTP, Trichy is looking for offers to supply Gaskets as per Drg. & Non Metallic Asbestos Gaskets -15 Items
PI refer the NIT Notification/Enquiry number for any further communication/correspondence .

Important Note to New Vendors (VIEWERS THROUGH BHEL WEB SITE)

The new vendors will be required to furnish the following documentary proof/ information (whichever applicable) along with their offers:

1. Certificate of registration (copy of certificate to be submitted).
2. Banker's information (copy of bank pass book first page to be submitted).
3. MSME vendor certificate (if applicable).
4. Address of your organization (complete postal address with PINCODE).
5. Contact person's Phone No. /Mobile No. / FAX No. /E-mail ID.
6. Statutory documents – VAT/TIN/EXCISE REGISTRATION/CST REGN /SERVICE TAX REGISTRATION etc. (copy to be furnished)
7. NSIC/SSI Certificate (if applicable)
8. ISO Certificate (if applicable)
9. Experience certificate as proof of supply of similar items to any Govt. agencies / PSU / Organisations (copy of PO's to be furnished).
10. Audit Report/ IT Return (if applicable)
11. Agency agreement with manufacturer (if applicable)
12. Partnership Deed (if applicable).

If the new vendors fail to submit the above documentary proof/information, their offers will not be considered for this enquiry.



Bharat Heavy Electricals Limited
(Seamless steel Tube Plant)
Tiruchirappalli – 620014, TAMIL NADU, INDIA

A) Important Note to MSE Vendors

1. 20% of the tendered quantity is earmarked for MSE suppliers in this tender.
2. Out of the 20% tendered quantity reserved for MSE suppliers, 4% shall be earmarked for procurement from MSE owned by SC / ST entrepreneurs.
3. In case MSE vendor participating in the tender quotes within the price band of L1 + 15%, they will be allowed to supply the portion of the requirement subject to acceptance of L1 price by MSE vendor. In case of more than one such MSE, the supply shall be shared proportionately.
4. MSE suppliers can avail the intended benefits only if they submit along with offer, attested copies of either EM II certificate having deemed validity (Two years from the date of issue of acknowledgement in EM II) or valid NSIC certificate or EM II certificate along with CA certificate (Format enclosed) applicable for the year, certifying quantum of investment in plant and machinery within the permissible limit as per the act for relevant status (Micro or small) where the deemed validity of EM II is over. Date to be reckoned for determining the deemed validity will be the last date of technical bid submission. Non submission of such documents will lead to consideration of their bids at par with other bidders and MSE status of such suppliers shall be shifted to Non MSE supplier till the supplier submits these documents.

Sr.Manager / Purchase /SSTP
Phone: 0431-257 8428.
Mail: rbmurugan@bheltry.co.in

 BHARAT HEAVY ELECTRICALS LIMITED (A GOVERNMENT OF INDIA UNDERTAKING) SEAMLESS STEEL TUBE PLANT TIRUCHIRAPALLI - 620 014. TAMILNADU (INDIA)	PHONE : 0431-2578480/8491 : 0431-2578406/8419 : 0431-2578568 FAX : 0431-2576828	TIN : 33243560005 CST. No. : 239383 Dated : 11.06.1991	<h1>PURCHASE ENQUIRY</h1>	
	VENDOR CODE 20021	ENQUIRY NUMBER 9440575E		ENQUIRY DATE 02/05/2014

Office Copy

IMPORTANT POINTS :

1. Tender Closing Time : 14.00 Hrs.
2. Tender Opening Time : 15.00 Hrs.
3. Tender should be submitted in a sealed cover, duly indicating enquiry No. Enquiry date & Enquiry Due Date on the cover.
4. Offer(s) received through Courier Services after 14.00 Hrs. on Enquiry Due Date will not be considered.
5. Late Tender(s) is/are liable for rejection.
6. Offer(s) shall be valid for 60 days from Enquiry Due Date.
7. Offer(s) in Vendor's Letter head shall contain.
 - a. Offer No. and Date
 - b. Delivery Period
 - c. Delivery Terms
 - d. Payment Terms
 - e. Excise Duty with Tariff Heading Sales Tax (against form-XVII/Form-C). etc.
 - f. Excise Regn. No. and SSI Regn. No.

Kindly arrange to submit your **COMPETITIVE OFFER** for the following item(s)
 If you are not in a position to submit your Offer, kindly arrange to send your **REGRET LETTER**.

THIS IS ONLY A REQUEST FOR OFFER AND NOT AN ORDER

No.	BHEL Material Code and Description	Unit	Requirement	
			Quantity	Delivery
01	BHEL Material Code : SP8531001202 ----- NON-METALIC ASBESTOS FIBRE JOINING GRADE : 0/1 SIZE : 1525 X 1800 MM THICKNESS : 1 MM	Kg.	01 50.000	23/06/2014
02	BHEL Material Code : SP8531001203 ----- NON-METALIC ASBESTOS FIBRE JOINING GRADE : 0/1 SIZE : 1525 X 1800 MM THICKNESS : 1.5 MM	Kg.	01 25.000	23/06/2014
03	BHEL Material Code : SP8531001204 ----- NON-METALIC ASBESTOS FIBRE JOINING GRADE : 0/1 SIZE : 1525 X 1800 MM THICKNESS : 2 MM	Kg.	01 50.000	23/06/2014
04	BHEL Material Code : SP8531001205 ----- NON-METALIC ASBESTOS FIBRE JOINING GRADE : 0/1 SIZE : 1525 X 1800 MM THICKNESS : 2.5 MM	Kg.	01 50.000	23/06/2014
05	BHEL Material Code : SP8531001206 ----- NON-METALIC ASBESTOS FIBRE	Kg.	01 50.000	23/06/2014

IMPORTANT NOTE :

Delivery Terms : "Free Delivery at BHEL-SSTP STORES" is preferable.
 Payment Terms : 100% payment after 45 days after receipt and acceptance of materials by BHEL.
 Terms and Conditions of Tender : Please see reverse.
 The Technical Requirements/Specification Details/Quality Requirements/Commercial Terms & Conditions are clearly furnished in the Tender. If Deviation(s) is/are not explicitly brought out in the Offer, it will be construed that the Tenderer is complying with the requirement of BHEL in full without any deviation(s).

For and on behalf of
BHARAT HEAVY ELECTRICALS LTD.

PURCHASE EXECUTIVE

 BHARAT HEAVY ELECTRICALS LIMITED (A GOVERNMENT OF INDIA UNDERTAKING) SEAMLESS STEEL TUBE PLANT TIRUCHIRAPALLI - 620 014. TAMILNADU (INDIA)	PHONE : 0431-2578480/8491 : 0431-2578406/8419 : 0431-2578568 FAX : 0431-2576828	TIN : 33243560005 CST. No. : 239383 Dated : 11.06.1991	<h1 style="margin: 0;">PURCHASE ENQUIRY</h1>		
	VENDOR CODE 20021	ENQUIRY NUMBER 9440575E			

Office Copy

IMPORTANT POINTS :

1. Tender Closing Time : 14.00 Hrs.
2. Tender Opening Time : 15.00 Hrs.
3. Tender should be submitted in a sealed cover, duly indicating enquiry No. Enquiry date & Enquiry Due Date on the cover.
4. Offer(s) received through Courier Services after 14.00 Hrs. on Enquiry Due Date will not be considered.
5. Late Tender(s) is/are liable for rejection.
6. Offer(s) shall be valid for 60 days from Enquiry Due Date.
7. Offer(s) in Vendor's Letter head shall contain.
 - a. Offer No. and Date
 - b. Delivery Period
 - c. Delivery Terms
 - d. Payment Terms
 - e. Excise Duty with Tariff Heading Sales Tax (against form-XVII/Form-C). etc.
 - f. Excise Regn. No. and SSI Regn. No.

Kindly arrange to submit your COMPETITIVE OFFER for the following item(s)
 If you are not in a position to submit your Offer, kindly arrange to send your REGRET LETTER.

THIS IS ONLY A REQUEST FOR OFFER AND NOT AN ORDER

No.	BHEL Material Code and Description	Unit	Requirement	
			Quantity	Delivery
	JOINING GRADE : 0/1 SIZE : 1525 X 1800 MM THICKNESS : 3 MM			
6	BHEL Material Code : SP8531001208 ----- NON-METALIC ASBESTOS FIBRE JOINING GRADE : 0/1 SIZE : 1525 X 1800 MM THICKNESS : 4 MM	Kg.	01 50.000	23/06/2014
7	BHEL Material Code : SP8531001210 ----- NON-METALIC ASBESTOS FIBRE JOINING GRADE : 0/1 SIZE : 1525 X 1800 MM THICKNESS : 5.0 MM	Kg.	01 25.000	23/06/2014
8	BHEL Material Code : SP9012392001 ----- GASKET-IV AS PER DRG:4-7-0123-99-06536 MATERIAL:CHAMPION STYLE 1910. FOR RADIANT TUBE FLANGE.	Nos.	01 200.000	05/08/2014
9	BHEL Material Code : SP9012392002 ----- GASKET-III AS PER DRG:4-7-0123-99-06535 MATERIAL:CHAMPION STYLE 1910. FOR I.D.AIR LINE EXHAUST.	Nos.	01 200.000	05/08/2014

IMPORTANT NOTE :

Delivery Terms : "Free Delivery at BHEL-SSTP STORES" is preferable.
 Payment Terms : 100% payment after 45 days after receipt and acceptance of materials by BHEL.
 Terms and Conditions of Tender : Please see reverse.
 The Technical Requirements/Specification Details/Quality Requirements/Commercial Terms & Conditions are
 clearly furnished in the Tender. If Deviation(s) is/are not explicitly brought out in the Offer, it will be construed that
 the Tenderer is complying with the requirement of BHEL in full without any deviation(s).

For and on behalf of
BHARAT HEAVY ELECTRICALS LTD.

PURCHASE EXECUTIVE



BHARAT HEAVY ELECTRICALS LIMITED
 (A GOVERNMENT OF INDIA UNDERTAKING)
 SEAMLESS STEEL TUBE PLANT
 TIRUCHIRAPALLI - 620 014.
 TAMILNADU (INDIA)

PHONE : 0431-2578480/8491
 : 0431-2578406/8419
 : 0431-2578568
 FAX : 0431-2576828

TIN : 33243560005
 CST. No. : 239383
 Dated : 11.06.1991

PURCHASE ENQUIRY

VENDOR CODE 20021	ENQUIRY NUMBER 9440575E	ENQUIRY DATE 02/05/2014	ENQUIRY DUE DATE 23/05/2014	No. OF ITEMS 15
-----------------------------	-----------------------------------	-----------------------------------	---------------------------------------	---------------------------

Office Copy

- IMPORTANT POINTS :**
1. Tender Closing Time : 14.00 Hrs.
 2. Tender Opening Time : 15.00 Hrs.
 3. Tender should be submitted in a sealed cover, duly indicating enquiry No. Enquiry date & Enquiry Due Date on the cover.
 4. Offer(s) received through Courier Services after 14.00 Hrs. on Enquiry Due Date will not be considered.
 5. Late Tender(s) is/are liable for rejection.
 6. Offer(s) shall be valid for 60 days from Enquiry Due Date.
 7. Offer(s) in Vendor's Letter head shall contain.
 - a. Offer No. and Date
 - b. Delivery Period
 - c. Delivery Terms
 - d. Payment Terms
 - e. Excise Duty with Tariff Heading Sales Tax (against form-XVII/Form-C). etc.
 - f. Excise Regn. No. and SSI Regn. No.

Kindly arrange to submit your COMPETITIVE OFFER for the following item(s)
 If you are not in a position to submit your Offer, kindly arrange to send your REGRET LETTER.

THIS IS ONLY A REQUEST FOR OFFER AND NOT AN ORDER

No.	BHEL Material Code and Description	Unit	Requirement	
			Quantity	Delivery
10	BHEL Material Code : SP9012392003 ----- GASKET-II AS PER DRG:4-7-0123-99-06534 MATERIAL:CHAMPION STYLE 1910. FOR RECUPERATOR.	Nos.	01 200.000	05/08/2014
11	BHEL Material Code : SP9012392004 ----- GASKET-I AS PER DRG:4-7-0123-99-06533 MATERIAL:CHAMPION STYLE 1910. FOR COMBUSTION AIR LINE.	Nos.	01 200.000	05/08/2014
12	BHEL Material Code : SP9012392005 ----- GASKET-VI AS PER DRG:4-7-0123-99-06539 MATERIAL:CHAMPION STYLE 1910. FOR COMBUSTION AIR LINE.	Nos.	01 200.000	05/08/2014
13	BHEL Material Code : SP9012392006 ----- GASKET-VII AS PER DRG:4-7-0123-99-06540 MATERIAL:CHAMPION STYLE 1910. FOR LPG LINE.	Nos.	01 200.000	05/08/2014
14	BHEL Material Code : SP9012392007			

IMPORTANT NOTE :
 Delivery Terms : *Free Delivery at BHEL-SSTP STORES" is preferable.
 Payment Terms : 100% payment after 45 days after receipt and acceptance of materials by BHEL.
 Terms and Conditions of Tender : Please see reverse.
 The Technical Requirements/Specification Details/Quality Requirements/Commercial Terms & Conditions are clearly furnished in the Tender. If Deviation(s) is/are not explicitly brought out in the Offer, it will be construed that the Tenderer is complying with the requirement of BHEL in full without any deviation(s).

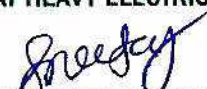
For and on behalf of
BHARAT HEAVY ELECTRICALS LTD.

PURCHASE EXECUTIVE



BHARAT HEAVY ELECTRICALS LIMITED
(A GOVERNMENT OF INDIA UNDERTAKING)
SEAMLESS STEEL TUBE PLANT
TIRUCHIRAPALLI - 620 014.
TAMILNADU (INDIA)

PHONE : 0431-2578480/8491
: 0431-2578406/8419
: 0431-2578568
FAX : 0431-2576828

TIN : 33243560005

CST. No. : 239383
Dated : 11.06.1991

PURCHASE ENQUIRY

VENDOR CODE 20021	ENQUIRY NUMBER 9440575E	ENQUIRY DATE 02/05/2014	ENQUIRY DUE DATE 23/05/2014	No. OF ITEMS 15
-----------------------------	-----------------------------------	-----------------------------------	---------------------------------------	---------------------------

Office Copy

IMPORTANT POINTS :

1. Tender Closing Time : 14.00 Hrs.
2. Tender Opening Time : 15.00 Hrs.
3. Tender should be submitted in a sealed cover, duly indicating enquiry No. Enquiry date & Enquiry Due Date on the cover.
4. Offer(s) received through Courier Services after 14.00 Hrs. on Enquiry Due Date will not be considered.
5. Late Tender(s) is/are liable for rejection.
6. Offer(s) shall be valid for 60 days from Enquiry Due Date.
7. Offer(s) in Vendor's Letter head shall contain.
 - a. Offer No. and Date
 - b. Delivery Period
 - c. Delivery Terms
 - d. Payment Terms
 - e. Excise Duty with Tariff Heading Sales Tax (against form-XVII/Form-C). etc.
 - f. Excise Regn. No. and SSI Regn. No.

Kindly arrange to submit your **COMPETITIVE OFFER** for the following item(s)
If you are not in a position to submit your Offer, kindly arrange to send your **REGRET LETTER**.

THIS IS ONLY A REQUEST FOR OFFER AND NOT AN ORDER

No.	BHEL Material Code and Description	Unit	Requirement	
			Quantity	Delivery
	GASKET-VIII AS PER DRG:4-7-0123-99-06541 MATERIAL:CHAMPION STYLE 1910. FOR LPG LINE.	Nos.	01 200.000	05/08/2014
5	BHEL Material Code : SP9012392008 GASKET-V AS PER DRG:4-7-0123-99-06537 MATERIAL:CHAMPION STYLE 1910. FOR RECUPERATOR.	Nos.	01 200.000	05/08/2014
	Foot Note :: THIS TENDER IS FLOATED ON TWO BID BASIS.REFER THE ANNEX.- A,B & C ATTACHED. CONFIRM THE FOLLOWING TECHNICAL/COMMERCIAL POINTS WITHOUT FAIL: 1)Following details are enclosed. (a)Annexure-A - Important Note to Tenderers. Tenderers are requested to submit their Offers in TWO-BID basis,via (i)Part I-Technical and Un-Priced Commercial Bid, (ii) Part II - Price Bid (b)Annexure-B & C - Payment Terms & Commercial Conditions 2)Tenderers are required to fill in above Annexure-B and C and enclose them along with Technical/Un-Priced Commercial Bid with out fail. (Offer shall be consider for further processing those who accepts the Clauses in Annexure-B & C.1 to C.5 of Annexure- C). 3)a. Delivery date furnished in the Enquiry is only indicative. b. For Delivery Schedule - Pl. refer Clause No. C.4 of Annexure- C. 4)Annexure-D Note to MSE Vendors enclosed. Send your MSE Certificate accordingly. 5)All the New Vendors (VIEWERS THROUGH BHEL WEB SITE),Read all the "Important Note to New Vendors" and furnish all the necessary documentary proofs along with Part-I Technical Bid. 6)AS THE GASKET IS USED FOR LPG LINE APPLPLICATION PURPOSE (Enq. sl- 8 to 15) 7)TEST CERTIFICATE AND CATALOGUE PAGE HAS TO BE SEND WITH ENQUIRY.			

IMPORTANT NOTE :

Delivery Terms : "Free Delivery at BHEL-SSTP STORES" is preferable.
Payment Terms : 100% payment after 45 days after receipt and acceptance of materials by BHEL.
Terms and Conditions of Tender : Please see reverse.
The Technical Requirements/Specification Details/Quality Requirements/Commercial Terms & Conditions are
furnished in the Tender. If Deviation(s) is/are not explicitly brought out in the Offer, it will be construed that
the Tenderer is complying with the requirement of BHEL in full without any deviation(s).

For and on behalf of
BHARAT HEAVY ELECTRICALS LTD.

Snoddy
PURCHASE EXECUTIVE

ALL DIMENSIONS ARE IN MM

S27-009 CAUTION: THE INFORMATION ON THIS DOCUMENT IS THE PROPERTY OF BHARAT HEAVY ELECTRICALS LTD IT MUST NOT BE USED DIRECTLY OR INDIRECTLY IN ANYWAY DETERMINAL TO INTEREST OF THE COMPANY

REV	DATE	ALTERED
01		CHECKED
		APPROVED

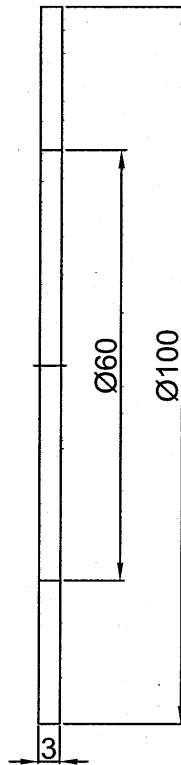

			CHAMPION STYLE 1910	
ITEM NO	DESCRIPTION	DRAWING NO	MATL CODE	UNIT WT
			MATL SPEC	QTY

EQPT: HEAT TREATMENT FURNACE 7.5T



Bharat Heavy Electricals Ltd
SEAMLESS STEEL TUBE PLANT
TIRUCHIRAPALLI - 620014

DRN	NAME	SIGNATURE	DATE
CHD	R.VIGNESH WARAN		6.10.08
APPD	S.S.N.KUMAR		
	A.SAHUL HAMEED		

DEPT	GRADE OF UNTOOL DIM	SCALE	WEIGHT (Kg)	REF TO ASSY DRG	ITEM NO
MPG	$\phi/M/\#$	1:2.5		REF TO OLD DRG	
CODE	IS: 2102				
TITLE			CARD CODE	DRAWING NO :	REV
GASKET-I			U 01	4-7-0123-99-06533	00
COMBUSTION AIR LINE					

ALL DIMENSIONS ARE IN MM

S27-009

CAUTION: THE INFORMATION ON THIS DOCUMENT IS THE PROPERTY OF BHARAT HEAVY ELECTRICALS LTD
IT MUST NOT BE USED DIRECTLY OR INDIRECTLY IN ANYWAY DETERMINAL TO INTEREST OF THE COMPANY

REV	DATE	ALTERED
01		CHECKED
		APPROVED

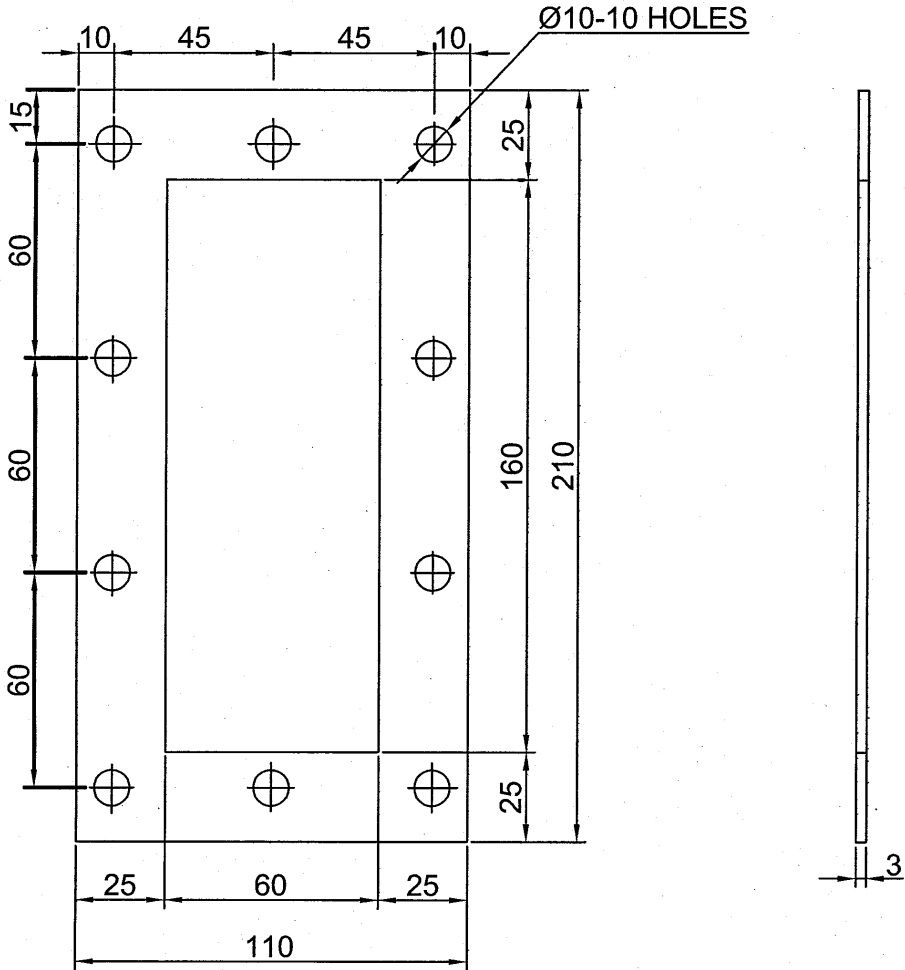

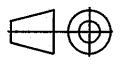
				CHAMPION STYLE 1910		
ITEM NO	DESCRIPTION	DRAWING NO	MATL CODE		UNIT WT	
			MATL SPEC		QTY	
EQPT: HEAT TREATMENT FURNACE 7.5T						
 Bharat Heavy Electricals Ltd SEAMLESS STEEL TUBE PLANT TIRUCHIRAPALLI - 620014		DRN	NAME	SIGNATURE	DATE	
		CHD	R.VIGNESH WARAN		6.10.08	
		APPD	S.S.N.KUMAR			
DEPT		GRADE OF	SCALE	WEIGHT (Kg)	REF TO ASSY DRG	ITEM NO
MPG	UNTOL, DIM	IS: 2102				
CODE			1:2.5		REF TO OLD DRG	
TITLE				CARD CODE	DRAWING NO :	REV
GASKET-II RECUPERATOR				U 01	4-7-0123-99-06534	00

ALL DIMENSIONS ARE IN MM

S27-009 CAUTION: THE INFORMATION ON THIS DOCUMENT IS THE PROPERTY OF BHARAT HEAVY ELECTRICALS LTD IT MUST NOT BE USED DIRECTLY OR INDIRECTLY IN ANYWAY DETERMINAL TO INTEREST OF THE COMPANY

REV	DATE	ALTERED
01		CHECKED
		APPROVED

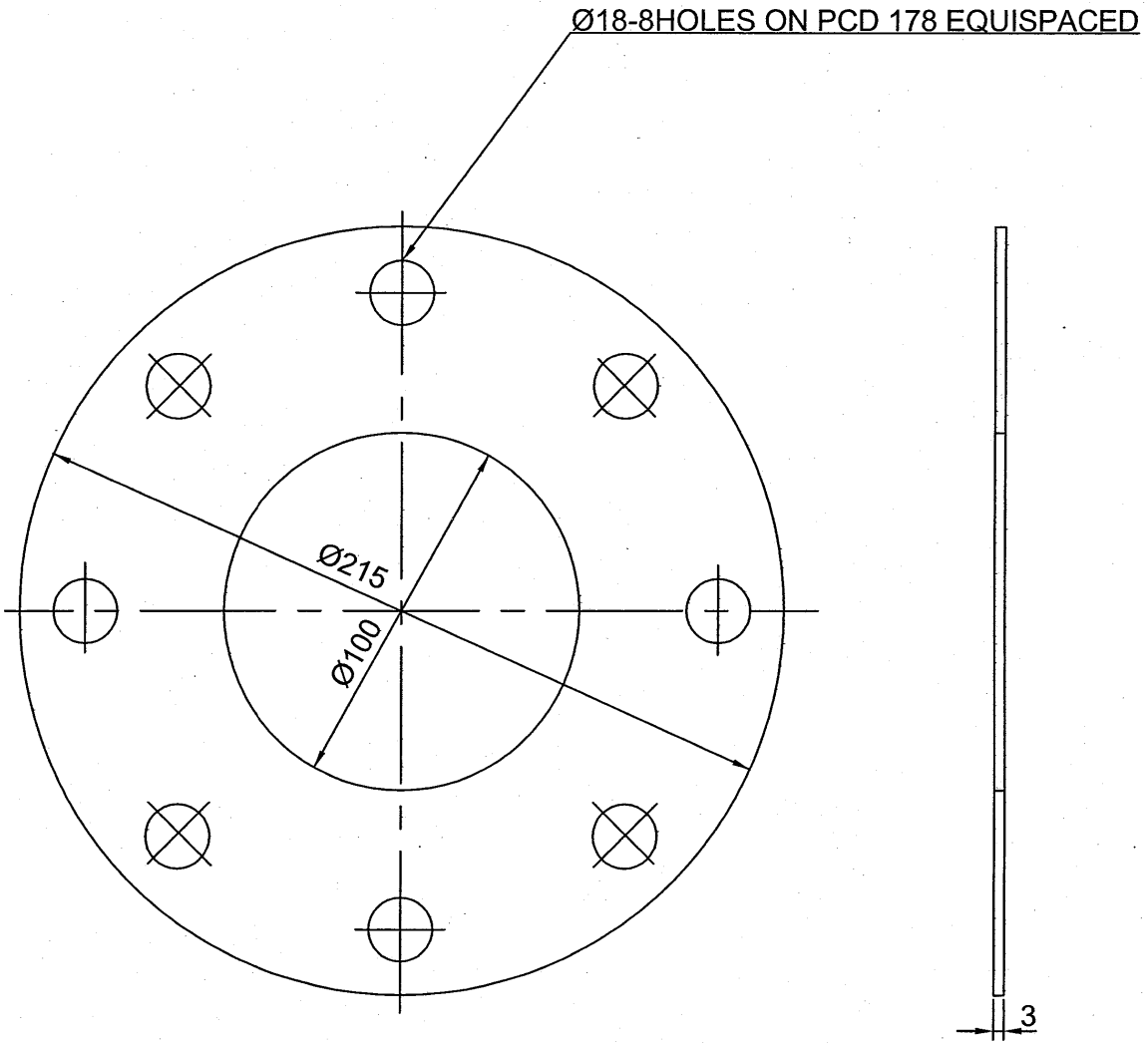

ITEM NO	DESCRIPTION	DRAWING NO	CHAMPION STYLE 1910	UNIT WT
			MATL CODE	QTY
			MATL SPEC	

EQPT: HEAT TREATMENT FURNACE 7.5T



Bharat Heavy Electricals Ltd
SEAMLESS STEEL TUBE PLANT
TIRUCHIRAPALLI - 620014

DRN	NAME	SIGNATURE	DATE
CHD	R.VIGNESH WARAN		6.10.08
APPD	S.S.N.KUMAR		
	A.SAHUL HAMEED		

DEPT MPG	GRADE OF UNTOL DIM φ/M/∅ IS: 2102	SCALE 1:2.5	WEIGHT (Kg)	REF TO ASSY DRG	ITEM NO
CODE				REF TO OLD DRG	
TITLE GASKET-III I.D AIR LINE EXHAUST			CARD CODE U 01	DRAWING NO : 4-7-0123-99-06535	REV 00

ALL DIMENSIONS ARE IN MM

S27-009

CAUTION: THE INFORMATION ON THIS DOCUMENT IS THE PROPERTY OF BHARAT HEAVY ELECTRICALS LTD
IT MUST NOT BE USED DIRECTLY OR INDIRECTLY IN ANYWAY DETERMINAL TO INTEREST OF THE COMPANY

REV	DATE	ALTERED
01		CHECKED
		APPROVED

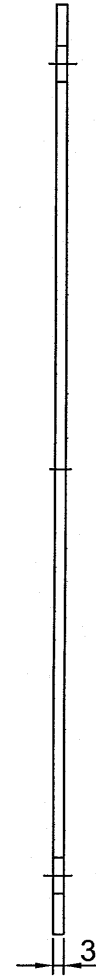
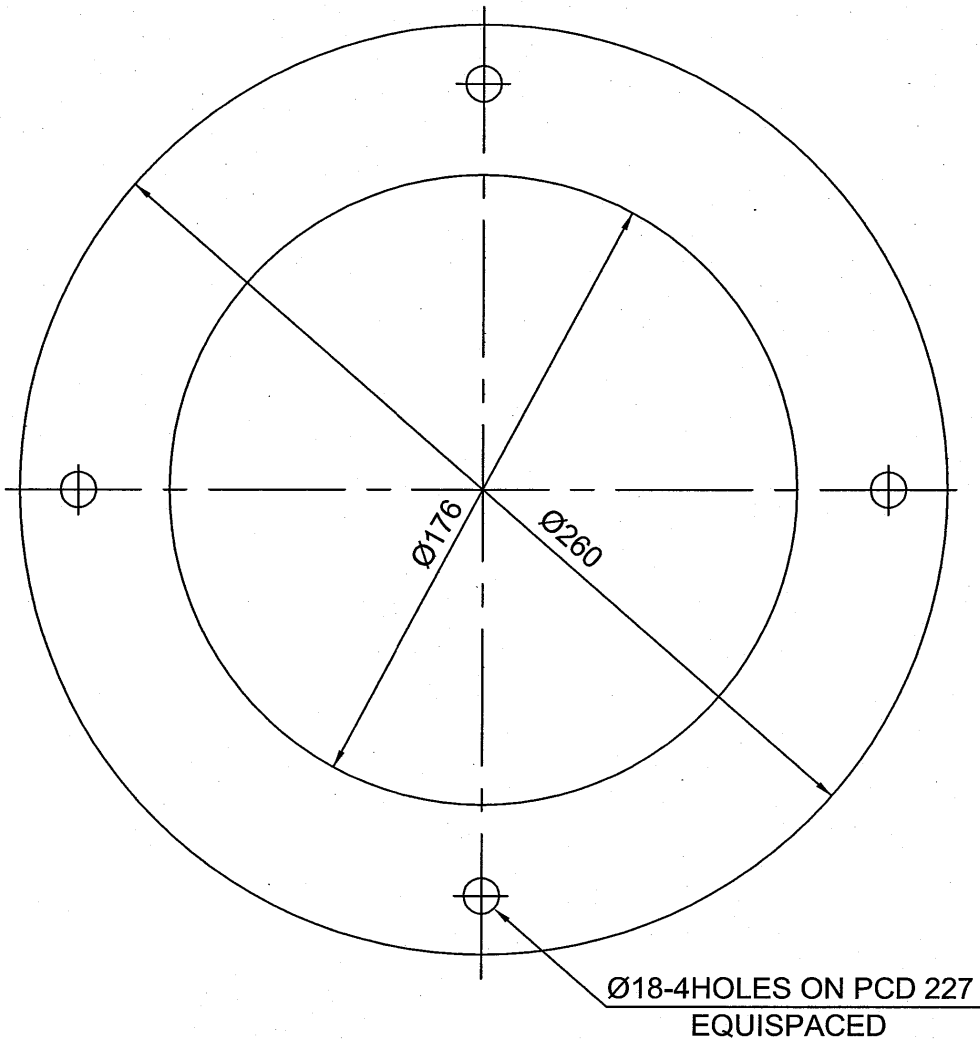

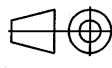
				CHAMPION STYLE 1910		
ITEM NO	DESCRIPTION	DRAWING NO	MATL CODE		UNIT WT	
			MATL SPEC		QTY	
EQPT: HEAT TREATMENT FURNACE 7.5T						
 Bharat Heavy Electricals Ltd SEAMLESS STEEL TUBE PLANT TIRUCHIRAPALLI - 620014		DRN	NAME	SIGNATURE	DATE	
		CHD	R.VIGNESH WARAN		6.10.08	
		APPD	S.S.N.KUMAR			
DEPT		GRADE OF	SCALE	WEIGHT (Kg)	REF TO ASSY DRG	
MPG	UNTOL. DIM	IS: 2102			1:2.5	REF TO OLD DRG
CODE	Φ/M/F				ITEM NO	
TITLE				CARD CODE	DRAWING NO :	REV
GASKET-IV				U 01	4-7-0123-99-06536	00
RADIANT TUBE FLANGE						

ALL DIMENSIONS ARE IN MM

527-009 THE INFORMATION ON THIS DOCUMENT IS THE PROPERTY OF BHARAT HEAVY ELECTRICALS LTD IT MUST NOT BE USED DIRECTLY OR INDIRECTLY IN ANYWAY DETERMINAL TO INTEREST OF THE COMPANY

REV	DATE	ALTERED
01		CHECKED
		APPROVED

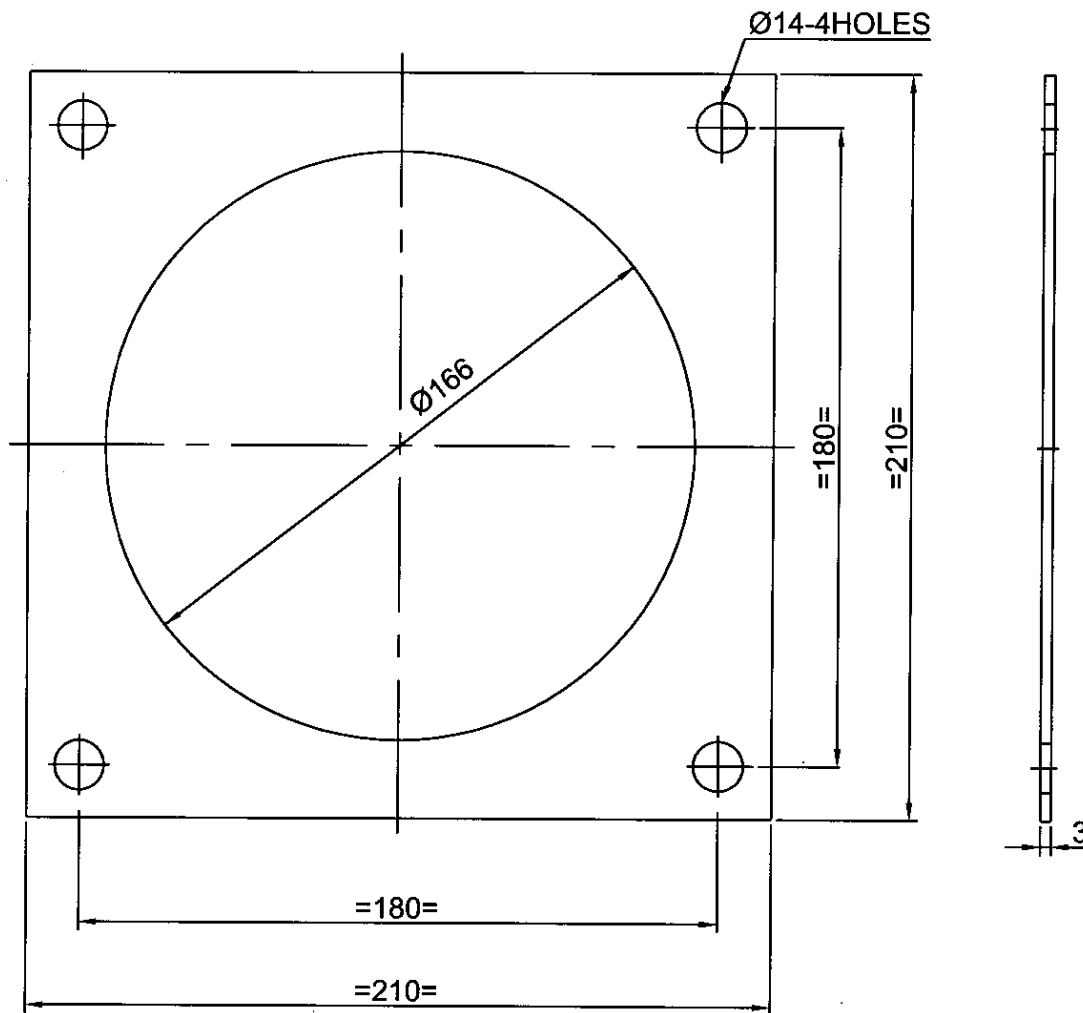

ITEM NO	DESCRIPTION	DRAWING NO	CHAMPION STYLE 1910	UNIT WT
			MATL CODE	QTY
			MATL SPEC	

EQPT: HEAT TREATMENT FURNACE 7.5T



Bharat Heavy Electricals Ltd
SEAMLESS STEEL TUBE PLANT
TIRUCHIRAPALLI - 620014

DRN	NAME	SIGNATURE	DATE
CHD	R.VIGNESH WARAN	<i>R. Vignesh Waran</i>	6.10.08
APPD	S.S.N.KUMAR	<i>S.S.N. Kumar</i>	
	A.SAHUL HAMEED	<i>A. Sahul Hameed</i>	06/10/08

DEPT	GRADE OF UNTOL. DIM	SCALE	WEIGHT (Kg)	REF TO ASSY DRG	ITEM NO
CODE	Q/M/F IS: 2102	1:2.5		REF TO OLD DRG	

TITLE	CARD CODE	DRAWING NO :	REV
GASKET-V RECUPERATOR	U 01	4-7-0123-99-06537	00

ALL DIMENSIONS ARE IN MM

S27-009 BHARAT HEAVY ELECTRICALS LTD IT MUST NOT BE USED DIRECTLY OR INDIRECTLY IN ANYWAY DETERMINANT TO INTEREST OF THE COMPANY

REV 01	DATE	ALTERED
		CHECKED
		APPROVED

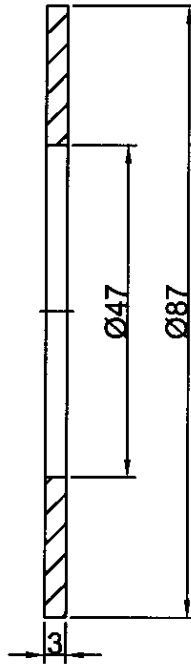

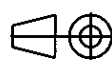
				CHAMPION STYLE 1910		
ITEM NO	DESCRIPTION	DRAWING NO	MATL CODE		UNIT WT	
			MATL SPEC		QTY	
EQPT: HEAT TREATMENT FURNACE 7.5T						
 Bharat Heavy Electricals Ltd SEAMLESS STEEL TUBE PLANT TIRUCHIRAPALLI - 620014		DRN	NAME R.VIGNESH WARAN	SIGNATURE <i>R.Vignesh</i>	DATE 5.11.08	
		CHD	S.S.N.KUMAR	<i>S.S.N.Kumar</i>	5/11/08	
		APPD	A.SAHUL HAMEED	<i>A.Sahul Hameed</i>	05/11/08	
DEPT MPG	GRADE OF UNTOL. DIM G/M/F IS: 2102		SCALE 1:1	WEIGHT (Kg)	REF TO ASSY DRG	ITEM NO
CODE					REF TO OLD DRG	
TITLE GASKET-VI COMBUSTION AIR LINE			CARD CODE U 01	DRAWING NO : 4-7-0123-99-06539		REV 00

ALL DIMENSIONS ARE IN MM



S27-009

BHARAT HEAVY ELECTRICALS LTD

IT MUST NOT BE USED DIRECTLY OR INDIRECTLY IN ANYWAY DETERMINANT TO INTEREST OF THE COMPANY

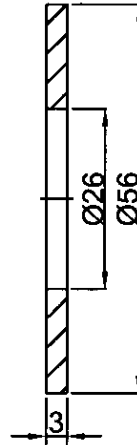
REV 01	DATE	ALTERED
		CHECKED
		APPROVED

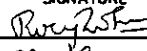
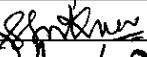
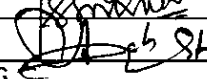

				CHAMPION STYLE 1910		
ITEM NO	DESCRIPTION	DRAWING NO	MATL CODE		UNIT WT	
			MATL SPEC		QTY	
EQPT: HEAT TREATMENT FURNACE 7.5T						
		Bharat Heavy Electricals Ltd SEAMLESS STEEL TUBE PLANT TIRUCHIRAPALLI - 620014		DRN R.VIGNESH WARAN	SIGNATURE 	DATE 5.11.08
				CHD S.S.N.KUMAR	SIGNATURE 	DATE 5/11/08
				APPD A.SAHUL HAMEED	SIGNATURE 	DATE 05/11/08
DEPT MPG	GRADE OF UNTOL DIM		SCALE	WEIGHT (Kg)	REF TO ASSY DRG	ITEM NO
CODE	Q/M/F IS: 2102		1:1		REF TO OLD DRG	
TITLE				CARD CODE	DRAWING NO :	REV
GASKET-VII LPG LINE				U 01	4-7-0123-99-06540	00

ALL DIMENSIONS ARE IN MM

S27-009
BHARAT HEAVY ELECTRICALS LTD
IT MUST NOT BE USED DIRECTLY OR INDIRECTLY IN ANYWAY DETERMINAL TO INTEREST OF THE COMPANY

REV 01	DATE	ALTERED
		CHECKED
		APPROVED

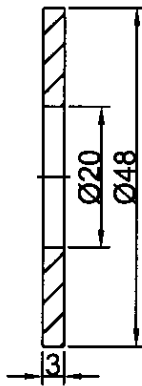

			CHAMPION STYLE 1910	
ITEM NO	DESCRIPTION	DRAWING NO	MATL CODE	UNIT WT
			MATL SPEC	QTY

EQPT: HEAT TREATMENT FURNACE 7.5T

	Bharat Heavy Electricals Ltd		DRN	NAME	SIGNATURE	DATE
	SEAMLESS STEEL TUBE PLANT		CHD	R.VIGNESH WARAN	<i>R. Vignesh Waran</i>	5.11.08
	TIRUCHIRAPALLI - 620014		APPD	S.S.N.KUMAR	<i>S.S.N. Kumar</i>	5/11/08

DEPT MPG	GRADE OF UNTOL. DIM		SCALE	WEIGHT (Kg)	REF TO ASSY DRG	ITEM NO
CODE	ϕ /M/# IS: 2102		1:1		REF TO OLD DRG	

TITLE	CARD CODE	DRAWING NO :	REV
GASKET-VIII LPG LINE	U 01	4-7-0123-99-06541	00

Annexure-A

Important Note to Tenderers - for TWO BID system (including REVERSE AUCTION)

(Page No. 1 of 4)

1. This Tender is floated on TWO–BID System.
 - A. Tenderers are requested to submit their Offers in TWO-BID basis, viz.
 - a. Part I .. Technical and Un-Priced Commercial Bid
 - b. Part II .. Price Bid
 - B Both the above Bids are to be submitted (or to be made available) before 14.00 hours (Indian Time) on Tender Due Date, as detailed under Para 3 below. **Tenders received after 14.00 Hrs. on the Tender Due Date, shall not be taken into consideration, irrespective of the mode of dispatch.**
2. Above Bids (Part I and Part II) are to be submitted in sealed-covers as detailed below:

A. Technical and Un-Priced Commercial Bid :

- a. Shall contain complete Scope of Supply with all Technical details, Specifications, Delivery Schedule, Delivery Terms, Payment Terms, Offer Validity, Taxes & Duties and other Commercial Terms & Conditions.
(Also please refer Clause No. 5 – General).
- b. Price columns are to be strictly filled-in only as ‘QUOTED’:

Enq. Sl. No.	BHEL Matl. Code / Description of Material.	Quantity with Unit Name	Unit Rate Rs.	Total Price Rs.
..	QUOTED	QUOTED
- c. Shall contain Point-wise confirmation for all Enquiry Clause Nos., TDC Clause Nos., and other attachments, if any.
- d. If any deviation is taken on Technical and / or Commercial points, the same shall be clearly highlighted in the Offer with Enquiry Clause No(s). and its attachments. Otherwise, it shall be construed by BHEL that the Tenderer is complying with all Enquiry Clauses in full.
- e. Any request for modification / change of Technical / Commercial points shall be entertained only before they are frozen.

B. Price Bid:

- a. Shall contain following details **only**:

Enq. Sl. No.	BHEL Matl. Code / Description of Material.	Quantity with Unit Name	Unit Rate Rs.	Total Price Rs.

- b. Wherever required / possible, Break-up-Price details are to be furnished.
- c. This Bid shall NOT contain any Technical and/or Commercial Conditions.
(If indicated, such terms shall not be taken into consideration).

Annexure-A

Important Note to Tenderers - for TWO BID system (including REVERSE AUCTION)

(Page No. 2 of 4)

3. **Details for submitting the Offer:**

A. **Cover No.1 – Technical and Un-Priced Commercial Bid :**

- a. Put the Technical & Un-Priced Commercial Bid inside Cover No.1 seal it.
- b. Mark Cover No.1 :
“Part-I -- TECHNICAL and UN-PRICED COMMERCIAL BID”
Tender No., Tender Date, Tender Due date, Address of Tenderer.

B. **Cover No.2 -- Price Bid :**

- a. Put the Price Bid inside Cover No.2 and seal it.
- b. Mark Cover No.2 :
“Part-II - PRICE BID”
Tender No., Tender Date, Tender Due date, Address of Tenderer.

C. **Cover No.3 -- Techno-Commercial Bid & Price Bid :**

- a. Put Cover No. 1 and 2 inside Cover No.3 and seal it.
- b. Mark Cover No. 3, with Tender No., Tender Date, Tender Due date, Address of Tenderer.
- c. Address the Cover No.3, to ::
Purchase Executive,
BHEL/SSTP,
Tiruchirapalli-620014, INDIA.

4. **Tender Opening:**

- A. On the Tender Due Date, Technical and Un-Priced Commercial Bid (Ref: 1.A.a. and 3.A. above), shall alone be opened, at the pre-fixed time, in presence of Responded Tenderers / their Authorized Representative, who may like to be present for Tender opening.
- B. Clarifications / Confirmations, if any, required by BHEL for Technical / Commercial evaluation, shall be sought from Bidders before opening the Price Bid.
- C. Price Bid of Technically suitable Bidders alone shall be opened, on a pre-determined date and time, in presence of the Responded Tenderers / their Authorized Representative, who may like to be present for such opening.

5. **General:**

- A. Incomplete Offers shall be liable for rejection.
- B. Fixed Price:
Bidder shall quote only Fixed Rate / Price and not subject to any escalation whatsoever during the period of Bid Validity and execution of Purchase Order. Any Bid with adjustable or price variation clause shall be treated as ‘Non-Responsive’ and liable for rejection. Prices shall be written both in numbers and words. In the event of any difference, the price in words shall be valid and binding. Unit Rate shall only be considered as correct and valid, which shall be taken for further consideration.

Annexure-A

Important Note to Tenderers - for TWO BID system (including REVERSE AUCTION)

(Page No. 3 of 4)

- C. Taxes and Duties:
All Taxes / Duties, if any, payable extra over and above the quoted rate, shall be specifically indicated in the Un-Priced Bid, failing which the quoted rates shall be considered as '**all inclusive**'.
- Offer shall carry clear details of Excise Tariff Heading No. and applicable Rate of ED / ST (along with Rate of Cess, if any).
- D. Validity of Offer:
Offer shall be kept valid for acceptance for a period of 60 days (sixty days) from the date of opening of the Technical & Un-Priced Bid.
- E. Terms of Payment:
Refer annexure B.
- F. Liquidated Damages, Risk Purchase and Warranty:
Refer annexure B
- G. Evaluation of the Offers shall be on the basis of 'To-Door Cost at SSTP' (NET Cash outflow to BHEL)
- H. BHEL reserves the right:
- a. to increase or decrease the tendered quantity(s) and split such quantities, for all or part of the Enquiry items, among more than one Tenderer based on commitments, requirements and capability of the Vendor(s), and finalise the Tender accordingly.
 - b. ~~to finalise order on Public Sector Enterprises under Price-Preference facilities as admissible in the existing policy.~~
 - c. to reject any Tender due to unsatisfactory past performance in the execution of a Contract.
 - d. **to resort for a REVERSE AUCTION (RA), i.e. ON-LINE BIDDING THROUGH INTERNET**, instead of opening the Sealed Price Bid submitted earlier, which shall be decided after evaluation of **TECHNICAL and UN-PRICED COMMERCIAL BID**
- I. **In case BHEL decides NOT to resort for RA, Price Bids and Price-Impacts, if any, already submitted by Bidder and available with BHEL, shall be opened, as detailed under Point 4 above.**
- J. **Information and General Terms and Conditions governing RA, are detailed below**

Against this enquiry for the subject item/ system with detailed scope of supply as per enquiry specifications, BHEL may resort to "REVERSE AUCTION PROCEDURE" i.e., ON LINE BIDDING (THROUGH A SERVICE PROVIDER). The philosophy followed for reverse auction shall be English Reverse (No ties).

Annexure-A

Important Note to Tenderers - for TWO BID system (including REVERSE AUCTION)

(Page No. 4 of 4)

1. For the proposed reverse auction, technically and commercially acceptable bidders only shall be eligible to participate.
2. Those bidders who have given their acceptance for Reverse Auction (quoted against this tender enquiry) will have to necessarily submit, online sealed bid in the Reverse Auction. Non-submission of „online sealed bid“ by the bidder for any of the eligible items for which techno commercially qualified, will be considered as tampering of the tender process and will invite action by BHEL as per extant guidelines in vogue.
3. BHEL will engage the services of a service provider who will provide all necessary training and assistance before commencement of on line bidding on internet.
4. In case of reverse auction, BHEL will inform the bidders the details of Service Provider to enable them to contact & get trained.
5. Business rules like event date, time, bid decrement, extension etc. also will be communicated through service provider for compliance.
6. Bidders have to fax the Compliance form (annexure IV) before start of Reverse auction. Without this, the bidder will not be eligible to participate in the event.
7. In line with the NIT terms, BHEL will provide the calculation sheet (e.g., EXCEL sheet) which will help to arrive at “Total Cost to BHEL” like Packing & forwarding charges, Taxes and Duties, Freight charges, Insurance, Service Tax for Services and loading factors (for noncompliance to BHEL standard Commercial terms & conditions) for each of the bidder to enable them to fill-in the price and keep it ready for keying in during the Auction.
8. Reverse auction will be conducted on scheduled date & time.
9. At the end of Reverse Auction event, the lowest bidder value will be known on auction portal.
10. The lowest bidder has to fax/e-mail the duly signed and filled-in prescribed format for price breakup including that of line items, if required, (Annexure VII) as provided on case-to-case basis to Service provider within two working days of Auction without fail.
11. In case BHEL decides not to go for Reverse Auction procedure for this tender enquiry, the Price bids and price impacts, if any, already submitted and available with BHEL shall be opened as per BHEL s standard practice.
12. Bidders shall be required to read the “Terms and Conditions” section of the auctions site of Service provider, using the Login IDs and passwords given to them by the service provider before reverse auction event. Bidders should acquaint themselves of the „Business Rules of Reverse Auction“, which will be communicated before the Reverse Auction.
13. If the Bidder or any of his representatives are found to be involved in Price manipulation/ cartel formation of any kind, directly or indirectly by communicating with other bidders, action as *per extant BHEL guidelines*, shall be initiated by BHEL and the results of the RA scrapped/ aborted.
14. The Bidder shall not divulge either his Bids or any other exclusive details of BHEL to any other party.
15. In case BHEL decides to go for reverse auction, the H1 bidder (whose quote is highest in online sealed bid) may not be allowed to participate in further RA process.

KINDLY PROVIDE FOLLOWING INFORMATION, IN CASE OF REVERSE AUCTION TO BE CONDUCTED

NAME OF THE PERSON:

MOBILE NO. :

LAND LINE NO. :

FAX NO. :

EMAIL ID :

.....oo0oo.....

Annexure – B.
PAYMENT TERMS

Vendor Code:	Vendor Name:	
Tender No.:	Tender Date:	Tender Due Date:

IMPORTANT NOTE TO SUPPLIERS:	
If materials are receivable at Stores/Trichy <u>without PBG</u>	Payment term is 100% direct payment after 45 days from the date of receipt and acceptance of materials.
If materials are receivable at Stores/Trichy <u>with PBG</u>	Payment term is 100% direct payment after 45 days from the date of receipt and acceptance of materials and against 10% PBG valid for the warranty period.
Any deviation in the above payment term will attract loading as mentioned below. “Base rate of SBI (as applicable on the date of Techno-commercial bid opening) + 6% will be loaded for the period of relaxation sought by bidders.	

Payment through bank	Payment through Bank is not preferred. In case of Payment through Bank is opted by Supplier, BHEL prefers documents submission through bank with copy of LR and door delivery of Goods to Site/Stores with Consignee copy attached. In this case Loading will be 3% on the offered value.
	Offers of indigenous Suppliers with payment terms as LC/Advance Payment are liable for rejection.

Liquidated Damages / Penalty
a. Liquidated damages shall be 0.5% of the total order value per week or part thereof subject to a maximum of 10% of the total order value.
b. For staggered delivery schedule, LD shall be 0.5% of the undelivered portion per week of the delay or part thereof subject to a maximum of 10% of the total order value.
c. Any deviation from the above LD clause, loading will be applied to the extent to which it is not agreed by the bidder (at offered value).

Guarantee / Warranty Period
Normally No deviation permitted and the deviated offers are liable for rejection.

Performance Bank Guarantee
Normally No deviation permitted and the deviated offers are liable for rejection.

BHEL will consider the ranking after the loading is applied as referred above wherever deviations are observed.

Annexure – C.
Commercial Conditions

Vendor Code:	Vendor Name:		
Tender No.:	Tender Date:	Tender Due Date:	

Sl. No.	Commercial Terms	Accepted	If Not accepted , give details
C 1.	<u>Delivery Terms:</u> Free delivery at BHEL/SSTP Stores. (including Packing, Forwarding, Freight and Insurance charges)		
C 2.	<u>Payment term :</u> 100% direct payment after 45 days from the date of receipt and acceptance of materials		
C 3.	Liquidated damages @ ½% per week subject to maximum of 10% of the order value shall be applicable for delay in deliveries		
C 4.	<u>Delivery:</u>	<u>indicate no. of weeks</u>	
C 5.	<u>Validity of Offer</u> - 60 Days from the Date of Tender Opening.		
C 6.	<u>Guarantee certificate:</u> shall cover total period of 18 months from date of dispatch or 12 months from the date of actual usage of the material whichever is earlier		
C 7.	<u>Erection and Commissioning(if applicable)</u> Erection / commissioning charges if any has to be mentioned in the offer or else it will be assumed that Erection/ commissioning will be done at free of cost	<u>Pl indicate applicability</u>	
Remarks, if any (attach additional sheet, if required) :			

Sl. No.	Commercial Terms	Vendor to fill in
C 8.	a. Excise Duty Tariff Heading	
	b. Excise Duty (%)	
	c. CESS on ED (%)	
	d. Total of ED and CESS (%)	
C 9.	a. TVNAT (%)	
	b. CST (%)	
C 10.	Other Cost (if any) - % (or) Rs.	
C 11.	Are you Micro/Small/Medium Industry?	Yes / No.
	If YES, please furnish MSM Regn. No. along with a copy of MSM Certificate	MSM No. :
		MSM Certificate Enclosed : Yes / No

Signature with Date	Seal

Certificate by Chartered Accountant

This is to Certify that M/S
(hereinafter referred to as 'company') having its registered office at
..... is registered under MSMED Act 2006, (Entrepreneur
MeMemorandum No (Part—II)..... dtd:.....,
Category:..... (Micro/Small)). (Copy enclosed).

Further verified from the Books of Accounts that the investment of the company as on
date as per MSMED Act 2006 is as follows:

1. **For Manufacturing Enterprises: Investment in plant and machinery** (i.e. original cost excluding land and building and the items specified by the Ministry of Small Scale Industries vide its notification No.5.0.1722(E) dated October 5, 2006:
Rs.Lacs
2. **For Service Enterprises: Investment in equipment** (original cost excluding land and building and furniture, fittings and other items not directly related to the service rendered or as may be notified under the MSMED Act, 2006:
Rs.Lacs

The above investment of Rs..... Lacs is within permissible limit of
RsLacs for Micro / Small (~~Strike off which is not applicable~~)
Category under MSMED Act 2006.

Date:

(Signature)

Name -

Membership number -

Seal of Chartered Accountant