



Bharat Heavy Electricals Limited
(Seamless steel Tube Plant)
Tiruchirappalli – 620014, TAMIL NADU, INDIA

TITLE: SUPPLY OF OILSEALS,O-RINGS,V-RINGS,RUBBER BUFFER ETC	Phone: +91 431 257 8428 Email : rbmurugan@bheltry.co.in Web : www.bhel.com
--	---

Enquiry Number: 9431425E	Date: 28.03.2014	Due date for submission of application: 18.04.2014
---------------------------------	-------------------------	---

BHEL/SSTP, Trichy is looking for offers to supply OILSEALS,O-RINGS, V-RINGS, RUBBER BUFFER ETC – 43 ITEMS

Pl refer the NIT Notification/Enquiry number for any further communication/correspondence .

Important Note to New Vendors

The new vendors will be required to furnish the following documentary proof/information (whichever applicable) along with their offers:

1. Certificate of registration (copy of certificate to be submitted).
2. Banker's information (copy of bank pass book first page to be submitted).
3. MSME vendor certificate (if applicable).
4. Address of your organization (complete postal address with PINCODE).
5. Contact person's Phone No. / Mobile No. / FAX No. / E-mail ID.
6. Statutory documents – VAT/TIN/EXCISE REGISTRATION/CST REGN /SERVICE TAX REGISTRATION etc. (copy to be furnished)
7. NSIC/SSI Certificate (if applicable)
8. ISO Certificate (if applicable)
9. Experience certificate as proof of supply of similar items to any Govt. agencies / PSU / Organisations (copy of PO's to be furnished).
10. Audit Report/ IT Return (if applicable)
11. Agency agreement with manufacturer (if applicable)
12. Partnership Deed (if applicable).

If the new vendors fail to submit the above documentary proof/information, their offers will not be considered for this enquiry.



An ISO 9001
Company

Bharat Heavy Electricals Limited (Seamless steel Tube Plant)

Tiruchirappalli – 620014, TAMIL NADU, INDIA

A) Important Note to MSE Vendors

1. 20% of the tendered quantity is earmarked for MSE suppliers in this tender.
2. Out of the 20% tendered quantity reserved for MSE suppliers, 4% shall be earmarked for procurement from MSE owned by SC / ST entrepreneurs.
3. In case MSE vendor participating in the tender quotes within the price band of L1 + 15%, they will be allowed to supply the portion of the requirement subject to acceptance of L1 price by MSE vendor. In case of more than one such MSE, the supply shall be shared proportionately.
4. MSE suppliers can avail the intended benefits only if they submit along with offer, attested copies of either EM II certificate having deemed validity (Two years from the date of issue of acknowledgement in EM II) or valid NSIC certificate or EM II certificate along with CA certificate (Format enclosed) applicable for the year, certifying quantum of investment in plant and machinery within the permissible limit as per the act for relevant status (Micro or small) where the deemed validity of EM II is over. Date to be reckoned for determining the deemed validity will be the last date of technical bid submission. Non submission of such documents will lead to consideration of their bids at par with other bidders and MSE status of such suppliers shall be shifted to Non MSE supplier till the supplier submits these documents.

Sr.Manager / Purchase /SSTP

Phone: 0431-257 8428.

Mail: rbmurugan@bheltry.co.in



BHARAT HEAVY ELECTRICALS LTD.
 (A GOVERNMENT OF INDIA UNDERTAKING)
 SEAMLESS STEEL TUBE PLANT
 TIRUCHIRAPPALLI - 620 014,
 TAMIL NADU.

PHONE : 0431-2576483,
 2578547, 2578428,
 2578436
 FAX : 0431-2520434/333

TIN : 33243560005

CST No. 238083
 Dated 11.06.1991

PURCHASE ENQUIRY

VENDOR CODE
 22002

ENQUIRY NUMBER
 9431425E

ENQUIRY DATE
 28/03/2014

ENQUIRY DUE DATE
 18/04/2014

No. OF ITEMS
 43

Office Copy

IMPORTANT POINTS :

1. Tender Closing Time - 14.00 Hrs.
2. Tender Opening Time - 15.00 Hrs.
3. Tender should be submitted in a sealed cover, duly indicating enquiry No., Enquiry date & Enquiry Due Date on the cover.
4. Offers received through Courier Services after 14.00 hrs. or Enquiry Due Date, not be considered.
5. Late Tender (s) is/are liable for rejection.
6. Offer(s) shall be valid for 60 days from Enquiry Due Date.
7. Offer(s) in Vendor's Letter-Head shall contain,
 - a. Offer No. and Date
 - b. Delivery Period
 - c. Delivery Terms
 - d. Payment Terms
 - e. Excise Duty with Draft Heading Sales Tax (against Form XXIII Form-C), etc.
 - f. Excise Regn. No. and ISI Regn. No.

Kindly arrange to submit your **COMPETITIVE OFFER** for the following item(s).
 If you are not in a position to submit your Offer, kindly arrange to send your **REGRET LETTER**.

THIS IS ONLY A REQUEST FOR OFFER AND NOT AN ORDER

Sl.No.	BHEL Material Code and Description	Unit	Requirement		
			Quantity	Delivery	
01	BHEL Material Code : SP8568008071 ----- OIL SEAL AS PER IS:5129/1969 SIZE : A195x235x16 MATERIAL : HARD NEOPRENE SHORE HARDNESS : 80 DEG.A	Nos.	01	5.000	07/07/2014
02	BHEL Material Code : SP8568005195 ----- V-RING SIZE : V95S MATERIAL : HARD NEOPRENE SHORE HARDNESS : 80-90 DEG.A	Nos.	01	5.000	07/07/2014
03	BHEL Material Code : SP8568005130 ----- V-RING SIZE : V65-S MATERIAL : HARD NEOPRENE SHORE HARDNESS : 80-90 deg.A REF.No. : MERCEL-3990	Nos.	01	5.000	10/07/2014
04	BHEL Material Code : SP9112357010 ----- RUBBER BUFFER REG.NO.4-7-1123-57-10253 MATL:HARD RUBBER SHORE:(A) 80-85	Nos.	01	12.000	10/05/2014
05	BHEL Material Code : SP9113611013 -----				

IMPORTANT NOTE:

1. Delivery Terms : "Free Delivery at BHEL-SSTP STORES" is preferable.
2. Payment Terms : 100% payment within 45days after receipt and acceptance of materials by BHEL.
3. Terms and Conditions of Tender : Please see reverse
4. The Technical Requirements / Specification Details / Quality Requirements/Commercial Terms & Conditions are clearly furnished in the Tender. If Deviations/are not explicitly brought out in the Offer, it will be construed that the Tenderer is complying with the requirement of BHEL in full without any deviation(s).

For and on behalf of
BHARAT HEAVY ELECTRICALS LTD.

Sreedhar
PURCHASE EXECUTIVE



BHARAT HEAVY ELECTRICALS LTD.
 (A GOVERNMENT OF INDIA UNDERTAKING)
 SEAMLESS STEEL TUBE PLANT
 TIRUCHIRAPPALLI - 620 014,
 TAMIL NADU.

PHONE : 0431-2578483,
 2578547, 2578428,
 2576436
 FAX : 0431-2520464/383

TIN : 33243560005
 GST No. 239383
 Dated 11.08.1991

PURCHASE ENQUIRY

VENDOR CODE
 22002

ENQUIRY NUMBER
 9431425E

ENQUIRY DATE
 28/03/2014

ENQUIRY DUE DATE
 18/04/2014

No. OF ITEM
 43

Office Copy

IMPORTANT POINTS :

1. Tender Closing Time - 14.00 Hrs.
2. Tender Opening Time - 15.00 Hrs.
3. Tender should be submitted in a sealed cover duly indicating enquiry No., Enquiry date & Enquiry Due Date on the cover.
4. Offers received through Courier Services after 14.00 Hrs. on Enquiry Due Date, will not be considered.
5. Late Tender (s) is/are liable for rejection.
6. Offers shall be valid for 60 days from Enquiry Due Date.
7. Offers in Vendor's Letter-head shall contain:
 - a. Offer No. and Date
 - b. Delivery Period
 - c. Delivery Terms
 - d. Payment Terms
 - e. Excess Duty with Tariff Heading Sales Tax (against form XVII/Form-G), etc.
 - f. Excess Regn. No. and ISI Regn. No.

Kindly arrange to submit your **COMPETITIVE OFFER** for the following item(s).
 If you are not in a position to submit your Offer, kindly arrange to send your **REGRET LETTER**.

THIS IS ONLY A REQUEST FOR OFFER AND NOT AN ORDER

Sl.No.	BHEL Material Code and Description	Unit	Requirement	
			Quantity	Delivery
	RUBBER BUFFER DRG NO:4-7-1134-05-00058 MATL :HARD RUBBER & C20, IS:226	Nos. 01	6.000	07/05/2014
06	BHEL Material Code : SP8551010166 "O"-RING (WIRE DIA X INNER DIA) SIZE : 2x85 mm MATERIAL : NEOPRENE RUBBER SHORE HARDNESS : 80-90 DEG.A	Nos. 01	50.000	12/05/2014
07	BHEL Material Code : SP8551010174 "O"-RING (WIRE DIA X INNER DIA) SIZE : 2x65mm MATERIAL : NEOPRENE RUBBER SHORE HARDNESS : 80-90 DEG.A	Nos. 01	50.000	12/05/2014
08	BHEL Material Code : SP8551013050 O-RING (WIRE DIA X INNER DIA) SIZE : 2.4x15.3mm MATL : NEOPRENE RUBBER SHORE HARDNESS : 80-90 DEG.A	Nos. 01	50.000	12/05/2014
09	BHEL Material Code : SP8551013181 "O" - RING (WIRE DIA X INNER DIA) 2.5 X 18 mm , MATERIAL :NEOPRENE RUBBER, SHORE HARDNESS ; 80 -	Nos. 01	50.000	12/05/2014

IMPORTANT NOTE :

Delivery Terms : Free Delivery at BHEL-SSTP STORES is preferable.
 Payment Terms : 100% payment within 45 days after receipt and acceptance of materials by BHEL.
 Terms and Conditions of Tender : Please see reverse.
 The Technical Requirements / Specification Details / Quality Requirements/Commercial Terms & Conditions are clearly furnished in the Tender. If deviations/objections are not explicitly brought out in the Offer, it will be construed that the Tenderer is complying with the requirement of BHEL in full without any deviations.

For and on behalf of
BHARAT HEAVY ELECTRICALS LTD.

Shreejay
PURCHASE EXECUTIVE



BHARAT HEAVY ELECTRICALS LTD.
 (A GOVERNMENT OF INDIA UNDERTAKING)
 SEAMLESS STEEL TUBE PLANT
 TIRUCHIRAPPALLI - 620 014,
 TAMIL NADU.

PHONE : 3431-2578483,
 2578547,2578428
 2578436
 FAX : 3431-2520434/533

TIN : 33243560005
 GST No. 299383
 Dated 11.06.1991

PURCHASE ENQUIRY

VENDOR CODE 22982	ENQUIRY NUMBER 9431425E	ENQUIRY DATE 28/03/2014	ENQUIRY DUE DATE 18/04/2014	No.OF ITEMS 43
----------------------	----------------------------	----------------------------	--------------------------------	-------------------

Office Copy

- IMPORTANT POINTS :**
1. Tender Closing Time - 14.30 Hrs.
 2. Tender Opening Time - 15.30 Hrs.
 3. Tender should be submitted in a sealed cover, clearly indicating enquiry No, Enquiry date & Enquiry Due Date on the cover.
 4. Offer(s) received through Courier Services after 14.30 Hrs. or Enquiry Due Date will not be considered.
 5. Late Tender (s) is/are liable for rejection.
 6. Offer(s) shall be valid for 60 days from Enquiry Due Date.
 7. Offer(s) in Vendor's Letter-Head shall contain:
 - a. Offer No. and Date
 - b. Delivery Period
 - c. Delivery Terms
 - d. Payment Terms
 - e. Excise Duty with Tariff Heading Sales Tax (against form XXIB Form-01, etc.
 - f. Excise Regn. No. and SSI Regn. No.

Kindly arrange to submit your **COMPETITIVE OFFER** for the following item(s).
 If you are not in a position to submit your Offer, kindly arrange to send your **REGRET LETTER**.

THIS IS ONLY A REQUEST FOR OFFER AND NOT AN ORDER

No.	BHEL Material Code and Description	Unit	Requirement		
			Quantity	Delivery	
0	BHEL Material Code : SP8551013221 O-RING (WIRE DIA & INNER DIA) SIZE : 2.40x27.50mm MATERIAL : NEOPRENE RUBBER SHORE HARDNESS: 80-90 DEG.A	NOS.	01	00.000	12/03/2014
1	BHEL Material Code : SP8551015001 O-RING (WIRE DIA INNER DIA) SIZE : 2.50x7mm MATERIAL : NEOPRENE RUBBER SHORE HARDNESS : 80-90 DEG.A	NOS.	01	00.000	12/03/2014
2	BHEL Material Code : SP8551015028 O-RING (WIRE DIA INNER DIA) SIZE : 2.5x12.00mm MATERIAL : NEOPRENE RUBBER SHORE HARDNESS : 80-90 DEG.A	Nos.	01	50.000	12/05/2014
3	BHEL Material Code : SP8551015036 O-RING SIZE: π 2.5 x 12.5 MATL: NEOPRENE SHORE HARDNESS 80-90xA	Nos.	01	50.000	12/05/2014
4	BHEL Material Code : SP8551015044				

IMPORTANT NOTE:

Delivery Terms : Free Delivery at BHEL'SSTP STORES' is preferable.
 Payment Terms : 100% payment within 45days after receipt and acceptance of materials by BHEL.
 Terms and Conditions of Tender : Please see reverse.
 The Technical Requirements / Specification Details / Quality Requirements/Commercial Terms & Conditions are clearly furnished in the Tender. If Deviation(s) is/are not explicitly brought out in the Offer, it will be construed that the Tenderer is complying with the requirement of BHEL in full without any deviation(s).

For and on behalf of
BHARAT HEAVY ELECTRICALS LTD.

Suresh Jay
PURCHASE EXECUTIVE



BHARAT HEAVY ELECTRICALS LTD.
 (A GOVERNMENT OF INDIA UNDERTAKING)
 SEAMLESS STEEL TUBE PLANT
 TIRUCHIRAPPALLI - 620 014,
 TAMIL NADU.

PHONE : 0431-2579480,
 2578547, 2578426,
 2578408
 FAX : 0431-2522464/363

TIN : 33243560005
 CST No. 299383
 Dated 11.06.1991

PURCHASE ENQUIRY

VENDOR CODE
22002

ENQUIRY NUMBER
9431425E

ENQUIRY DATE
28/03/2014

ENQUIRY DUE DATE
18/04/2014

No. OF ITEMS
43

Office Copy

- IMPORTANT POINTS :**
1. Tender Closing Time - 14.00 Hrs.
 2. Tender Opening Time - 15.00 Hrs.
 3. Tender should be submitted in a sealed cover, duly indicating enquiry No., Enquiry Date & Enquiry Due Date on the cover.
 4. Offers received through Courier Services after 14.00 Hrs. on Enquiry Due Date will not be considered.
 5. Late Tender (s) is/are liable for rejection.
 6. Offers shall be valid for 60 days from Enquiry Due Date.
 7. Offers in Vendor's Letter-Head shall contain,
 - a. Offer No. and Date
 - b. Delivery Period
 - c. Delivery Terms
 - d. Payment Terms
 - e. Excise Duty with Tariff Heading Sales Tax (against Form-XVII-Form-C), etc.
 - f. Excise Regn. No. and SSI Regn. No.

Kindly arrange to submit your **COMPETITIVE OFFER** for the following item(s)
 If you are not in a position to submit your Offer, kindly arrange to send your **REGRET LETTER**.

THIS IS ONLY A REQUEST FOR OFFER AND NOT AN ORDER

Sl.No.	BHEL Material Code and Description	Unit	Requirement	
			Quantity	Delivery
	O-RING (WIRE DIAxINNER DIA) SIZE : 2.50x15mm MATERIAL : NEOPRENE RUBBER SHORE HARDNESS : 80-90 DEG.A	Nos. 01	50.000	12/05/2014
15	BHEL Material Code : SP8551025155 O-RING (WIRE DIAxINNER DIA) SIZE : 3.00x79.5mm MATERIAL : NEOPRENE RUBBER SHORE HARDNESS : 80-90 DEG.A	Nos. 01	50.000	12/05/2014
16	BHEL Material Code : SP8551025201 O-RING (WIRE DIAxINNER DIA) SIZE : 3.00x52mm MATERIAL : NEOPRENE RUBBER SHORE HARDNESS : 80-90 DEG.A	Nos. 01	50.000	12/05/2014
17	BHEL Material Code : SP8551025252 O-RING (WIRE DIAxINNER DIA) SIZE : 3.00x26.2mm MATERIAL : NEOPRENE RUBBER SHORE HARDNESS : 80-90 DEG.A	Nos. 01	50.000	12/05/2014
18	BHEL Material Code : SP8551025317 O-RING (WIRE DIAxINNER DIA) SIZE : 3.00x30mm	Nos. 01	50.000	12/05/2014

IMPORTANT NOTE :

1. Delivery Terms : 'Free Delivery at BHEL-SSTP STORES' is preferable.
2. Payment Terms : 100% payment within 45days after receipt and acceptance of materials by BHEL.
3. Terms and Conditions of Tender : Please see reverse.
4. The Technical Requirements / Specification Details / Quality Requirements/Commercial Terms & Conditions are clearly furnished in the Tender. If Deviation(s) is/are not explicitly brought out in the Offer, it will be considered that the Tenderer is complying with the requirement of BHEL in full without any deviation(s).

For and on behalf of
BHARAT HEAVY ELECTRICALS LTD.

Sneha
PURCHASE EXECUTIVE



BHARAT HEAVY ELECTRICALS LTD.
 (A GOVERNMENT OF INDIA UNDERTAKING)
 SEAMLESS STEEL TUBE PLANT
 TIRUCHIRAPPALLI - 620 014,
 TAMIL NADU.

PHONE : 0431-2578480,
 2578547,2578423,
 2578406
 FAX : 0431-2520484/385

TIN : 33243560005
 CST No. 239383
 Dated 11.06.1991

PURCHASE ENQUIRY

VENDOR CODE 22002	ENQUIRY NUMBER 9431425E	ENQUIRY DATE 28/03/2014	ENQUIRY DUE DATE 18/04/2014	No. OF ITEMS 43
----------------------	----------------------------	----------------------------	--------------------------------	--------------------

Office Copy

- IMPORTANT POINTS :**
- Tender Closing Time - 14.00 Hrs.
 - Tender Opening Time - 15.00 Hrs.
 - Tender should be submitted in a sealed cover duly indicating enquiry No., Enquiry Date & Enquiry Due Date on the cover.
 - Offers received through Courier Services after 14.00 Hrs. on Enquiry Due Date will not be considered.
 - Late Tender (s) is/are liable for rejection.
 - Offers shall be valid for 60 days from Enquiry Due Date.
 - Offer(s) in Vendor's Letter-Head shall contain,
 - Offer No. and Date
 - Delivery Period
 - Delivery Terms
 - Payment Terms
 - Excise Duty with Tariff Heading Sanks Tax (against form-XVI/Form-C) etc.
 - Excise Regn. No. and SSII Regn. No.

Kindly arrange to submit your **COMPETITIVE OFFER** for the following item(s).
 If you are not in a position to submit your Offer, kindly arrange to send your **REGRET LETTER**.

THIS IS ONLY A REQUEST FOR OFFER AND NOT AN ORDER

Sl.No.	BHEL Material Code and Description	Unit	Requirement	
			Quantity	Delivery
	MATERIAL : NEOPRENE RUBBER SHORE HARDNESS : 80-90 DEG.A			
19	BHEL Material Code : SP8551025333 O-RING (WIRE DIAxINNER DIA) SIZE : 3.00x33.00mm MATERIAL : NEOPRENE RUBBER SHORE HARDNESS : 80-90 DEG.A	Nos. 01	50.000	12/05/2014
20	BHEL Material Code : SP8551025336 O-RING (WIRE DIA X INNER DIA) SIZE:3.00X34.00mm MATERIAL:NEOPRENE RUBBER SHORE HARDNESS:80-90 DEG.A	Nos. 01	50.000	12/05/2014
21	BHEL Material Code : SP8551025350 O-RING (WIRE DIAxINNER DIA) SIZE : 3.00x35mm MATERIAL : NEOPRENE RUBBER. SHORE HARDNESS : 80 - 90 DEG.A.	Nos. 01	50.000	12/05/2014
22	BHEL Material Code : SP8551025406 O-RING (WIRE DIAxINNER DIA) SIZE : 3.00x40mm MATERIAL : NEOPRENE RUBBER SHORE HARDNESS : 80-90 DEG.A	Nos. 01	50.000	12/05/2014

- IMPORTANT NOTE :**
- Delivery Terms : Free Delivery at BHEL-SSTP STORES* is preferable.
 - Payment Terms : 100% payment within 45days after receipt and acceptance of materials by BHEL*
 - Terms and Conditions of Tender : Please see reverse
 - The Technical Requirements / Specification Details / Quality Requirements/Commercial Terms & Conditions are clearly furnished in the Tender. If Deviation(s) is/are not explicitly brought out in the Offer, it will be construed that the Tenderer is complying with the requirement of BHEL, in full, without any deviation(s).

For and on behalf of
BHARAT HEAVY ELECTRICALS LTD.

Shreejy
PURCHASE EXECUTIVE



BHARAT HEAVY ELECTRICALS LTD.
 (A GOVERNMENT OF INDIA UNDERTAKING)
 SEAMLESS STEEL TUBE PLANT
 TIRUCHIRAPPALLI - 620 014,
 TAMIL NADU.

PHONE : 0431-2579480,
 2576547,2578428,
 2578405
 FAX : 0431-2523464/363

TIN: 33243560005
 GST No. 230383
 Dated 11.06.1991

PURCHASE ENQUIRY

VENDOR CODE 22002	ENQUIRY NUMBER 9431425E	ENQUIRY DATE 28/03/2014	ENQUIRY DUE DATE 18/04/2014	No. OF ITEMS 43
----------------------	----------------------------	----------------------------	--------------------------------	--------------------

Office Copy

- IMPORTANT POINTS :**
1. Tender Closing Time - 14.30 Hrs.
 2. Tender Opening Time - 15.30 Hrs.
 3. Tender should be submitted in a sealed cover, duly indicating enquiry No., Enquiry date & Enquiry Due Date on the cover.
 4. Offer(s) received through Courier Services after 14.30 Hrs. on Enquiry Due Date will not be considered.
 5. Late Tender(s) shall be liable for rejection.
 6. Offer(s) shall be valid for 60 days from Enquiry Due Date.
 7. Offer(s) in Vendor's Letter-Head shall contain:
 - a. Offer No. and Date
 - b. Delivery Period
 - c. Delivery Terms
 - d. Payment Terms
 - e. Excise Duty with Tariff Heading Sales Tax (against form-XVII Form-D), and
 - f. Excise Regn. No. and SSI Regn. No.

Kindly arrange to submit your **COMPETITIVE OFFER** for the following item(s).
 If you are not in a position to submit your Offer, kindly arrange to send your **REGRET LETTER**.

THIS IS ONLY A REQUEST FOR OFFER AND NOT AN ORDER

Sl.No.	BHEL Material Code and Description	Unit	Requirement	
			Quantity	Delivery
23	BHEL Material Code : SP8551025481 O-RING(WIRE DIA X INNER DIA) SIZE : 3.00X48.00 mm MATERIAL : NEOPRENE RUBBER SHORE HARDNESS:80-90 DEG.A	Nos. 01	50.000	12/05/2014
24	BHEL Material Code : SP8551025490 O-RING (WIRE DIAxINNER DIA) SIZE : 3.00x49mm MATERIAL : NEOPRENE RUBBER SHORE HARDNESS : 80-90 DEG.A	Nos. 01	50.000	12/05/2014
25	BHEL Material Code : SP8551025856 O-RING (WIRE DIAxINNER DIA) SIZE : 3.00x57.2mm MATERIAL : NEOPRENE RUBBER SHORE HARDNESS : 80-90 DEG.A	Nos. 01	50.000	12/05/2014
26	BHEL Material Code : SP8551025902 O-RING (WIRE DIAxINNER DIA) SIZE : 3.00x90mm MATERIAL : NEOPRENE RUBBER SHORE HARDNESS : 80-90 DEG.A	Nos. 01	50.000	12/05/2014
27	BHEL Material Code : SP8551025910			

- IMPORTANT NOTE :**
1. Delivery Terms : Free Delivery at BHEL-SSTP STORES is preferable.
 2. Payment Terms : 100% payment within 45days after receipt and acceptance of materials by BHEL.
 3. Terms and Conditions of Tender : Please see reverse.
 4. The Technical Requirements / Specification Details / Quality Requirements/Commercial Terms & Conditions are clearly furnished in the Tender. If Deviation(s) is/are not explicitly brought out in the Offer, it will be construed that the Tenderer is complying with the requirement of BHEL in full without any deviations.

For and on behalf of
BHARAT HEAVY ELECTRICALS LTD.

PURCHASE EXECUTIVE



BHARAT HEAVY ELECTRICALS LTD.
 (A GOVERNMENT OF INDIA UNDERTAKING)
 SEAMLESS STEEL TUBE PLANT
 TIRUCHIRAPPALLI - 620 014,
 TAMIL NADU.

PHONE : 0431-2578480,
 2578647, 2578428,
 2578406
 FAX : 0431-2523464/383

TIN : 33243560005

CST No. 239383
 Dated 11.06.1991

PURCHASE ENQUIRY

VENDOR CODE 22002	ENQUIRY NUMBER 9431425E	ENQUIRY DATE 28/03/2014	ENQUIRY DUE DATE 18/04/2014	NO. OF ITEMS 43
----------------------	----------------------------	----------------------------	--------------------------------	--------------------

Office Copy

IMPORTANT POINTS :

1. Tender Closing Time - 14.00 Hrs.
2. Tender Opening Time - 15.00 Hrs.
3. Tender should be submitted in a sealed cover, duly indicating enquiry No., Enquiry date & Enquiry Due Date on its cover.
4. Offers received through Courier Services after 14.00 Hrs. on Enquiry Due Date will not be considered.
5. Late Tender (s) is/are liable for rejection.
6. Offers shall be valid for 60 days from Enquiry Due Date.
7. Offer(s) in Vendor's Letter-head shall contain,
 - a. Offer No. and Date
 - b. Delivery Period
 - c. Delivery Terms
 - d. Payment Terms
 - e. Excise Duty with Tariff-Heading Sales Tax (against form-XVII Form-C), etc.
 - f. Excise Regn. No. and ISI Regn. No.

Kindly arrange to submit your **COMPETITIVE OFFER** for the following item(s).
 If you are not in a position to submit your Offer, kindly arrange to send your **REGRET LETTER**.

THIS IS ONLY A REQUEST FOR OFFER AND NOT AN ORDER

No.	BHEL Material Code and Description	Unit	Requirement	
			Quantity	Delivery
	O-RING (WIRE DIAxINNER DIA) SIZE : 3.00x104mm MATERIAL : NEOPRENE RUBBER SHORE HARDNESS : 80-90 DEG.A	Nos. 01	50.000	12/05/2014
	BHEL Material Code : SP8551025940 O-RING (WIRE DIAxINNER DIA) SIZE : 3.00x94mm MATERIAL : NEOPRENE RUBBER SHORE HARDNESS : 80-90 DEG.A	Nos. 01	50.000	12/05/2014
	BHEL Material Code : SP8551025945 O-RING (WIRE DIA X INNER DIA) SIZE: 3 X 138 mm. MATERIAL : NEOPRENE RUBBER, SHORE HARDNESS: 80 - 90 DEG.A.	Nos. 01	50.000	12/05/2014
	BHEL Material Code : SP8551027107 O-RING (WIRE DIAxINNER DIA) SIZE : 3.50x50.4mm MATERIAL : NEOPRENE RUBBER SHORE HARDNESS : 80-90 DEG.A	Nos. 01	50.000	12/05/2014
	BHEL Material Code : SP8551030000 O-RING (WIRE) CHORD : 3.00mm	Mtr. 01	50.000	12/05/2014

IMPORTANT NOTE :

Delivery Terms : "Free Delivery at BHEL-SSTP STORES" is preferable.
 Payment Terms : 100% payment within 45days after receipt and acceptance of materials by BHEL.
 Terms and Conditions of Tender : Please see reverse.
 The Technical Requirements / Specification Details / Quality Requirements/Commercial Terms & Conditions are clearly furnished in the Tender. If Deviations are not explicitly brought out in the Offer, it will be construed that the Tenderer is complying with the requirement of BHEL in full without any deviations.

For and on behalf of
BHARAT HEAVY ELECTRICALS LTD.

Shreejaya
PURCHASE EXECUTIVE



BHARAT HEAVY ELECTRICALS LTD.
 A GOVERNMENT OF INDIA UNDERTAKING
 SEAMLESS STEEL TUBE PLANT
 TIRUCHIRAPPALLI - 620 014,
 TAMIL NADU.

PHONE : 0431-2578480,
 2578547, 2578428,
 2578436
 FAX : 0431-2520464/383

TIN : 33243580005

CST No. 238383
 Dated 11.06.1991

PURCHASE ENQUIRY

VENDOR CODE
 22002

ENQUIRY NUMBER
 9431425E

ENQUIRY DATE
 28/03/2014

ENQUIRY DUE DATE
 18/04/2014

No. OF ITEMS
 43

Office Copy

IMPORTANT POINTS :

1. Tender Closing Time - 14.00 Hrs.
2. Tender Opening Time - 15.00 Hrs.
3. Tender should be submitted in a sealed cover, duly indicating enquiry No., Enquiry Date & Enquiry Due Date on the cover.
4. Offer(s) received through Courier Services after 14.00 Hrs. or Enquiry Due Date will not be considered.
5. Late Tender(s) is/are liable for rejection.
6. Offer(s) shall be valid for 60 days from Enquiry Due Date.
7. Offer(s) in Vendor's Letter-Head shall contain:
 - a. Offer No. and Date
 - b. Delivery Period
 - c. Delivery Terms
 - d. Payment Terms
 - e. Excise Duty with Tariff Heading Sales Tax (against Form XVI/Form-C), if applicable
 - f. Excise Regn. No. and SS. Regn. No.

Kindly arrange to submit your **COMPETITIVE OFFER** for the following item(s).
 If you are not in a position to submit your Offer, kindly arrange to send your **REGRET LETTER**.

THIS IS ONLY A REQUEST FOR OFFER AND NOT AN ORDER

Sl.No.	BHEL Material Code and Description	Unit	Requirement	
			Quantity	Delivery
	MATERIAL : NEOPRENE RUBBER SHORE HARDNESS : 80-90 DEG.A			
32	BHEL Material Code : SP8551030043 O-RING (WIRE DIA X INNER DIA) SIZE : 3.53x32mm MATERIAL : NEOPRENE RUBBER SHORE HARDNESS : 80-90 DEG.A	Nos.	01 50.000	12/05/2014
33	BHEL Material Code : SP8551030051 O-RING (WIRE DIA X INNER DIA) SIZE : 3.53x32.92mm MATERIAL : NEOPRENE RUBBER SHORE HARDNESS : 80-90 DEG.A	Nos.	01 50.000	12/05/2014
34	BHEL Material Code : SP8551030078 O-RING (WIRE DIA X INNER DIA) SIZE : 3.53x33.00 MATERIAL : NEOPRENE RUBBER SHORE HARDNESS: 80-90 DEG.A	Nos.	01 50.000	12/05/2014
35	BHEL Material Code : SP8551035037 O-RING (WIRE DIA X INNER DIA) SIZE : 4.00x14mm MATERIAL : NEOPRENE RUBBER SHORE HARDNESS : 80-90 DEG.A	Nos.	01 50.000	12/05/2014

IMPORTANT NOTE :

1. Delivery Terms : Free Delivery at BHEL -SSTP STORES* is preferable.
2. Payment Terms : 100% payment within 45days after receipt and acceptance of materials by BHEL.
3. Terms and Conditions of Tender : Please see reverse.
4. The Technical Requirements / Specification Details / Quality Requirements/Commercial Terms & Conditions are clearly furnished in the Tender. If Deviation(s) is/are not explicitly brought out in the Offer, it will be construed that the Tenderer is complying with the requirement of BHEL in full without any deviations.

For and on behalf of
BHARAT HEAVY ELECTRICALS LTD.

(Signature)
PURCHASE EXECUTIVE



BHARAT HEAVY ELECTRICALS LTD.
 (A GOVERNMENT OF INDIA UNDERTAKING)
 SEAMLESS STEEL TUBE PLANT
 TIRUCHIRAPPALLI - 620 014,
 TAMIL NADU.

PHONE : 0431-2578490,
 2578547,2578428,
 2578406
 FAX : 0431-2520434/383

TIN : 33243560005

CST No. 238383
 Dated 11.06.1991

PURCHASE ENQUIRY

VENDOR CODE
 22002

ENQUIRY NUMBER
 9431425E

ENQUIRY DATE
 28/03/2014

ENQUIRY DUE DATE
 18/04/2014

No. OF ITEMS
 43

Office Copy

IMPORTANT POINTS :

1. Tender Closing Time - 14.00 Hrs.
2. Tender Opening Time - 15.00 Hrs.
3. Tender should be submitted in a sealed cover, duly indicating enquiry No. Enquiry date & Enquiry Due Date on the cover.
4. Offer(s) received through Courier Services after 14.00 Hrs. of Enquiry Due Date, not be considered.
5. Late Tender (s) are liable for rejection.
6. Offer(s) shall be valid for 60 days from Enquiry Due Date.
7. Offer(s) in Vendor's Letter-Head shall contain:
 - a. Offer No. and Date
 - b. Delivery Period
 - c. Delivery Terms
 - d. Payment Terms
 - e. Excise Duty with Tariff Heading Sales Tax (against form XVII Form-C), etc.
 - f. Excise Regn. No. and ISI Regn. No.

Kindly arrange to submit your **COMPETITIVE OFFER** for the following item(s).
 If you are not in a position to submit your Offer, kindly arrange to send your **REGRET LETTER**.

THIS IS ONLY A REQUEST FOR OFFER AND NOT AN ORDER

Sl.No.	BHEL Material Code and Description	Unit	Requirement		
			Quantity	Delivery	
36	BHEL Material Code : SP8551035100 O-RING (WIRE DIAxINNER DIA) SIZE : 4.00x52mm MATERIAL : NEOPRENE RUBBER SHORE HARDNESS : 80-90 DEG.A	Nos.	01	50.000	12/05/2014
37	BHEL Material Code : SP8551035215 O-RING (WIRE DIA X INNER DIA) SIZE: 4 X 170 mm. MATERIAL : NEOPRENE RUBBER. SHORE HARDNESS: 80 - 90 DEG.A.	Nos.	01	50.000	12/05/2014
38	BHEL Material Code : SP8551035230 O-RING (WIRE DIA X INNER DIA) SIZE: 4 X 140 mm. MATERIAL : NEOPRENE RUBBER. SHORE HARDNESS: 80 - 90 DEG.A.	Nos.	01	50.000	12/05/2014
39	BHEL Material Code : SP8551035278 O-RING (WIRE DIA X INNER DIA) SIZE: 10 X 133 mm. MATERIAL : NEOPRENE RUBBER. SHORE HARDNESS: 80 - 90 DEG.A.	Nos.	01	50.000	12/05/2014

IMPORTANT NOTE :

Delivery Terms : Free Delivery at BHEL-SSTP STORES is preferable.
 Payment Terms : 100% payment within 45 days after receipt and acceptance of materials by BHEL.
 Terms and Conditions of Tender : Please see reverse.
 The Technical Requirements / Specification Details / Quality Requirements/Commercial Terms & Conditions are clearly furnished in the Tender. If Deviations (s) were not explicitly brought out in the Offer, it will be construed that the Tenderer is complying with the requirement of BHEL in full without any deviations.

For and on behalf of
BHARAT HEAVY ELECTRICALS LTD.

Sneeshy
PURCHASE EXECUTIVE

 S40-003/D	BHARAT HEAVY ELECTRICALS LTD. (A GOVERNMENT OF INDIA UNDERTAKING) SEAMLESS STEEL TUBE PLANT TIRUCHIRAPPALLI - 620 014, TAMIL NADU.	PHONE : 0431-2579460, 2578567, 2578429, 2578403 FAX : 0431-2523464/383	TIN : 33243560005 CST No. 239383 Dated 11.06.1991	PURCHASE ENQUIRY
		VENDOR CODE 22002	ENQUIRY NUMBER 9431425E	

Office Copy

IMPORTANT POINTS :

1. Tender Closing Time - 14.00 Hrs.
2. Tender Opening Time - 15.00 Hrs.
3. Tender should be submitted in a sealed cover, duly indicating enquiry No., Enquiry date & Enquiry Due Date on the cover.
4. Offer(s) received through Courier Services after 14.00 Hrs. on Enquiry Due Date, not be considered.
5. Late Tender(s) liable for rejection.
6. Offer(s) shall be valid for 90 days from Enquiry Due Date.
7. Offer(s) in Vendor's Letter Head shall contain:
 - a. Offer No. and Date
 - b. Delivery Period
 - c. Delivery Terms
 - d. Payment Terms
 - e. Excise Duty with Tariff Heading Sales Tax (against form-XVII Form-D), etc.
 - f. Excise Regn. No. and ESI Regn. No.

Kindly arrange to submit your **COMPETITIVE OFFER** for the following item(s).
 If you are not in a position to submit your Offer, kindly arrange to send your **REGRET LETTER**.

THIS IS ONLY A REQUEST FOR OFFER AND NOT AN ORDER

No.	BHEL Material Code and Description	Unit	Requirement		
			Quantity	Delivery	
0	BHEL Material Code : SP8551035285 O-RING (WIRE DIA X INNER DIA) SIZE: 5X145 mm. MATERIAL : NEOPRENE RUBBER. SHORE HARDNESS: 80 - 90 DEG.A.	Nos.	01	50.000	12/05/2014
1	BHEL Material Code : SP8551035336 O-RING (WIRE DIA X INNER DIA) SIZE : 4 X 168 mm. MATERIAL : NEOPRENE RUBBER. SHORE HARDNESS: 80 - 90 DEG.A.	Nos.	01	50.000	12/05/2014
2	BHEL Material Code : SP8551035363 'O' RING (WIRE DIA X INNER DIA) SIZE : 4.00X180mm MATERIAL : NEOPRENE RUBBER SHORE HARDNESS : 80-90 DEG.A	Nos.	01	50.000	12/05/2014
3	BHEL Material Code : SP8551040006 O-RING (WIRE) CHORD : 4.00mm MATERIAL : NEOPRENE RUBBER SHORE HARDNESS : 80-90 DEG.A	Mtr.	01	50.000	12/05/2014

IMPORTANT NOTE:

Delivery Terms: "Free Delivery at BHEL-SSTP STORES" is preferable.
 Payment Terms: 100% payment within 45days after receipt and acceptance of materials by BHEL.
 Terms and Conditions of Tender: Please see reverse.
 The Technical Requirements / Specification Details / Quality Requirements/Commercial Terms & Conditions are clearly furnished in the Tender. If Deviation(s) is/are not explicitly brought out in the Offer, it will be construed that the Tenderer is complying with the requirement of BHEL in full without any deviation(s).

For and on behalf of
BHARAT HEAVY ELECTRICALS LTD.

Shankar
PURCHASE EXECUTIVE



BHARAT HEAVY ELECTRICALS LTD.
 (A GOVERNMENT OF INDIA UNDERTAKING)
 SEAMLESS STEEL TUBE PLANT
 TIRUCHIRAPPALLI - 620 014,
 TAMIL NADU.

PHONE : 0431-2578480
 2578547,2578428,
 2578406
 FAX : 0431-2520434/393

TIN : 33243560005
 GST No. 299385
 Dated 11.06.1991

PURCHASE ENQUIRY

VENDOR CODE
 22032

ENQUIRY NUMBER
 9431425E

ENQUIRY DATE
 28/03/2014

ENQUIRY DUE DATE
 18/04/2014

No. OF ITEMS
 43

Office Copy

- IMPORTANT POINTS :**
1. Tender Closing Time - 14.00 Hrs.
 2. Tender Opening Time - 15.00 Hrs.
 3. Tender should be submitted in a sealed cover, duly indicating enquiry No., Enquiry Date & Enquiry Due Date on the cover.
 4. Offer(s) received through Courier Services after 14.00 Hrs. on Enquiry Due Date will not be considered.
 5. Late Tender (s) is/are liable for rejection.
 6. Offer(s) shall be valid for 60 days from Enquiry Due Date.
 7. Offer(s) in vendor's Letter-Head shall contain:
 - a. Offer No. and Date
 - b. Delivery Period
 - c. Delivery Terms
 - d. Payment Terms
 - e. Excise Duty with Tariff Inclusive Sales Tax (against form-XVII-Form-CI, etc.
 - f. Exces Regn. No. and SSI Regn. No.

Kindly arrange to submit your **COMPETITIVE OFFER** for the following item(s).
 If you are not in a position to submit your Offer, kindly arrange to send your **REGRET LETTER**.

THIS IS ONLY A REQUEST FOR OFFER AND NOT AN ORDER

Sl.No.	BHEL Material Code and Description	Unit	Requirement	
			Quantity	Delivery
	Foot Note :: ----- THIS TENDER IS CALLED ON TWO BID SYSTEM. KINDLY REFER THE ANNEX.-A, B & C ATTACHED. CONFIRM THE FOLLOWING TECH/COMMERCIAL POINTS WITHOUT FAIL: ----- 1) OUR STD PAYMENT TERMS: 100% PAYMENT WILL BE MADE AFTER 45 DAYS FROM THE DATE OF ACCEPTANCE OF MATERIALS AT OUR END. THRO E-PAYMENT. FORMAT WILL BE SENT ALONG WITH PURCHASE ORDER. 2) PL QUOTE THE RATE ON DOOR DELIVERY BASIS DULY INCLUDING PKG, FORWARDING, FREIGHT AND INSURANCE CHARGES. 3) CONFIRM YR ACCEPTANCE FOR LD AND RISK PURCHASE CLAUSES. 4) Annex B & C should be filled and Enclosed with Offer letter without fail.			

IMPORTANT NOTE:

1. Delivery Terms : "Free Delivery at BHEL-SSTP STORES" is preferable.
2. Payment Terms : 100% payment within 45 days after receipt and acceptance of materials by BHEL.
3. Terms and Conditions of Tender : Please see reverse.
4. The Technical Requirements / Specification Details / Quality Requirements/Commercial Terms & Conditions are clearly furnished in the Tender. If Deviations (s) are not explicitly brought out in the Offer, it will be construed that the Tenderer is complying with the requirement of BHEL in full without any deviations(s).

For and on behalf of
BHARAT HEAVY ELECTRICALS LTD.

[Signature]
PURCHASE EXECUTIVE

REGISTERED OFFICE : BHEL HOUSE, SRI FORT, NEW DELHI - 110 043.

ALL DIMENSIONS ARE IN MM

REF	DATE	ALTERED
Q1		CHECKED
		APPROVED

✓ (✓ Ra 3.2)

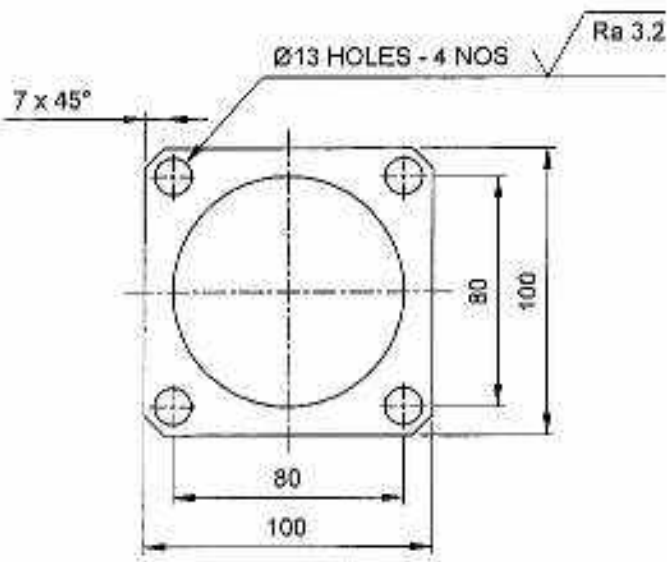
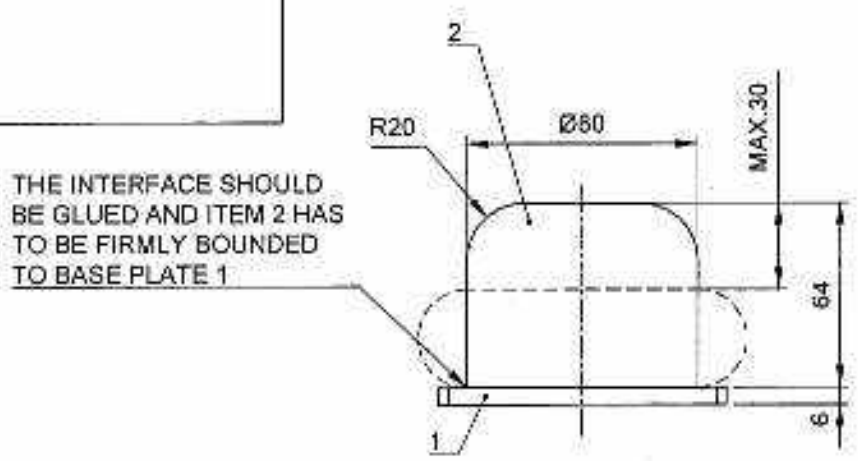

2	Ø 80 X 64 L		80 - 85 SHORE A	0.70
			HARD RUBBER	1
1	PL 100 X 100 X 6 IS 1730		E250 A IS:2062	0.45
ITEM NO	DESCRIPTION	DRAWING NO.	MATL CODE	UNIT WT
			MATL SPEC	QTY

CAUTION: THE INFORMATION ON THIS DOCUMENT IS THE PROPERTY OF BHARAT HEAVY ELECTRICALS LIMITED. IT MUST NOT BE USED DIRECTLY OR INDIRECTLY IN ANY WAY DETRIMENTAL TO THE INTEREST OF BHEL COMPANY.

EQPT. CROSS PIERCING AND ELONGATION - MAIN EQUIPMENT INCLUDING INLET PUSHER SIDE, OUTER SIDE AND THRUST BLOCK



Bharat Heavy Electricals Ltd
SEAMLESS STEEL TUBE PLANT
TRUCHRAPALL - 620014

DRN	NAME	SIGNATURE	DATE
	RAGHUVJEER/S.R.N	<i>R. Raghuvjeer/S.R.N</i>	05.02.14
CHD	SLOGAKATHAN	<i>S. Slogakathan</i>	05.02.14
APPD	V. CHANDRAKUMAR	<i>M. Chandrakumar</i>	05.02.14

DEPT	GRADE OF UNTOOL DM	SCALE	WEIGHT (Kg)	REF TO ASSY DWG NO	ITEM
SSTP				C101056-57.420	10
CODE	Q/N/E	1:2.5	1.15	REF TO OLD DWG NO	
466	IS 2192				

TITLE	CARD CODE	DRAWING NO.	REV
CPE - RUBBER BUFFER ROPE DRIVE CARRIAGE	U 01	4-7-1123-57-10253	00

FIRST ANGLE PROJECTION (ALL DIMENSIONS IN MILLIMETRES)

CAUTION THE INFORMATION ON THIS DOCUMENT IS THE PROPERTY OF BHARAT HEAVY ELECTRICALS LTD. IT MUST NOT BE USED DIRECTLY OR INDIRECTLY IN ANY WAY DETRIMENTAL TO THE INTEREST OF THE COMPANY.

REV 01	DATE	ALTERED
		CHECKED
ZONE		

~(▽)

THE INTERFACE SHOULD BE GLUED AND ITEM 2 HAS TO BE FIRMLY BONDED TO BASE PLATE 1

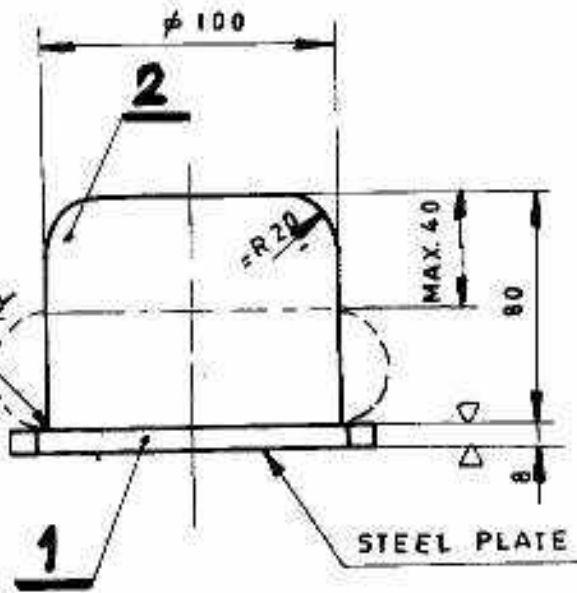

$F_{(max)} = 630 \text{ N}$
 $W_{(max)} = 8 \text{ NM}$

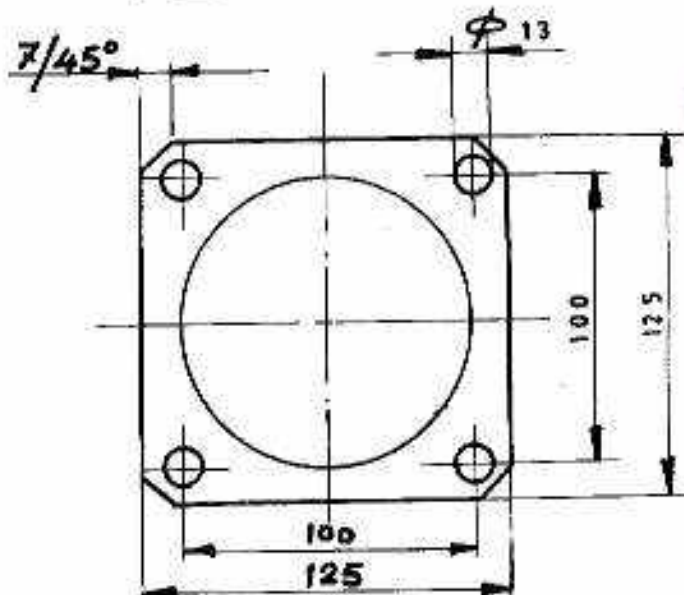

SHORE HARDNESS OF RUBBER 80° TO 85°A

2		HARD RUBBER	
1	BASE PLATE	18-226	
		CEO	
ITEM NO.	DESCRIPTION	MATL CODE	UNIT WT
		MATL SPEC	QTY

Eqpt:- REELER



Bharat Heavy Electricals Ltd.,
 SEAMLESS STEEL TUBE PLANT
 TIRUCHIRAPALLI - 620 014

DRN	NAME	SIGN	DATE
EC-007	S. MOHAN RAJ	S. Mohan Raj	21-2-84
CHD			21-2-84
APPD			21-2-84

DEPT	GRADE OF UNTOOL DIM	SCALE	WEIGHT (kg)	REF TO ASSY OLD DRG	ITEM NO.
CODE	C/M/F	1:2.5	1.5	01-21-006-11-008	
TITLE			CARD CODE	DRAWING NO.	REV
RUBBER BUFFER			U 01	4-7-1134-00-00058	00

Annexure-A

Important Note to Tenderers - for TWO BID system (including REVERSE AUCTION)

(Page No. 1 of 4)

1. This Tender is floated on TWO–BID System.
 - A. Tenderers are requested to submit their Offers in TWO-BID basis, viz.
 - a. Part I .. Technical and Un-Priced Commercial Bid
 - b. Part II .. Price Bid
 - B Both the above Bids are to be submitted (or to be made available) before 14.00 hours (Indian Time) on Tender Due Date, as detailed under Para 3 below.
Tenders received after 14.00 Hrs. on the Tender Due Date, shall not be taken into consideration, irrespective of the mode of dispatch.
2. Above Bids (Part I and Part II) are to be submitted in sealed-covers as detailed below:

A. Technical and Un-Priced Commercial Bid :

- a. Shall contain complete Scope of Supply with all Technical details, Specifications, Delivery Schedule, Delivery Terms, Payment Terms, Offer Validity, Taxes & Duties and other Commercial Terms & Conditions.
(Also please refer Clause No. 5 – General).
- b. Price columns are to be strictly filled-in only as ‘QUOTED’:

Enq. Sl. No.	BHEL Matl. Code / Description of Material.	Quantity with Unit Name	Unit Rate Rs.	Total Price Rs.
..	QUOTED	QUOTED
- c. Shall contain Point-wise confirmation for all Enquiry Clause Nos., TDC Clause Nos., and other attachments, if any.
- d. If any deviation is taken on Technical and / or Commercial points, the same shall be clearly highlighted in the Offer with Enquiry Clause No(s). and its attachments. Otherwise, it shall be construed by BHEL that the Tenderer is complying with all Enquiry Clauses in full.
- e. Any request for modification / change of Technical / Commercial points shall be entertained only before they are frozen.

B. Price Bid:

- a. Shall contain following details **only**:

Enq. Sl. No.	BHEL Matl. Code / Description of Material.	Quantity with Unit Name	Unit Rate Rs.	Total Price Rs.

- b. Wherever required / possible, Break-up-Price details are to be furnished.
- c. This Bid shall NOT contain any Technical and/or Commercial Conditions.
(If indicated, such terms shall not be taken into consideration).

Annexure-A

Important Note to Tenderers - for TWO BID system (including REVERSE AUCTION)

(Page No. 2 of 4)

3. **Details for submitting the Offer:**

A. **Cover No.1 – Technical and Un-Priced Commercial Bid :**

- a. Put the Technical & Un-Priced Commercial Bid inside Cover No.1 seal it.
- b. Mark Cover No.1 :
“Part-I -- TECHNICAL and UN-PRICED COMMERCIAL BID”
Tender No., Tender Date, Tender Due date, Address of Tenderer.

B. **Cover No.2 -- Price Bid :**

- a. Put the Price Bid inside Cover No.2 and seal it.
- b. Mark Cover No.2 :
“Part-II - PRICE BID”
Tender No., Tender Date, Tender Due date, Address of Tenderer.

C. **Cover No.3 -- Techno-Commercial Bid & Price Bid :**

- a. Put Cover No. 1 and 2 inside Cover No.3 and seal it.
- b. Mark Cover No. 3, with Tender No., Tender Date, Tender Due date, Address of Tenderer.
- c. Address the Cover No.3, to ::
Purchase Executive,
BHEL/SSTP,
Tiruchirapalli-620014, INDIA.

4. **Tender Opening:**

- A. On the Tender Due Date, Technical and Un-Priced Commercial Bid (Ref: 1.A.a. and 3.A. above), shall alone be opened, at the pre-fixed time, in presence of Responded Tenderers / their Authorized Representative, who may like to be present for Tender opening.
- B. Clarifications / Confirmations, if any, required by BHEL for Technical / Commercial evaluation, shall be sought from Bidders before opening the Price Bid.
- C. Price Bid of Technically suitable Bidders alone shall be opened, on a pre-determined date and time, in presence of the Responded Tenderers / their Authorized Representative, who may like to be present for such opening.

5. **General:**

- A. Incomplete Offers shall be liable for rejection.
- B. Fixed Price:
Bidder shall quote only Fixed Rate / Price and not subject to any escalation whatsoever during the period of Bid Validity and execution of Purchase Order. Any Bid with adjustable or price variation clause shall be treated as ‘Non-Responsive’ and liable for rejection. Prices shall be written both in numbers and words. In the event of any difference, the price in words shall be valid and binding. Unit Rate shall only be considered as correct and valid, which shall be taken for further consideration.

Annexure-A

Important Note to Tenderers - for TWO BID system (including REVERSE AUCTION)

(Page No. 3 of 4)

- C. Taxes and Duties:
All Taxes / Duties, if any, payable extra over and above the quoted rate, shall be specifically indicated in the Un-Priced Bid, failing which the quoted rates shall be considered as '**all inclusive**'.
- Offer shall carry clear details of Excise Tariff Heading No. and applicable Rate of ED / ST (along with Rate of Cess, if any).
- D. Validity of Offer:
Offer shall be kept valid for acceptance for a period of 60 days (sixty days) from the date of opening of the Technical & Un-Priced Bid.
- E. Terms of Payment:
Refer annexure B.
- F. Liquidated Damages, Risk Purchase and Warranty:
Refer annexure B
- G. Evaluation of the Offers shall be on the basis of 'To-Door Cost at SSTP' (NET Cash outflow to BHEL)
- H. BHEL reserves the right:
- a. to increase or decrease the tendered quantity(s) and split such quantities, for all or part of the Enquiry items, among more than one Tenderer based on commitments, requirements and capability of the Vendor(s), and finalise the Tender accordingly.
 - b. ~~to finalise order on Public Sector Enterprises under Price-Preference facilities as admissible in the existing policy.~~
 - c. to reject any Tender due to unsatisfactory past performance in the execution of a Contract.
 - d. **to resort for a REVERSE AUCTION (RA), i.e. ON-LINE BIDDING THROUGH INTERNET**, instead of opening the Sealed Price Bid submitted earlier, which shall be decided after evaluation of **TECHNICAL and UN-PRICED COMMERCIAL BID**
- I. **In case BHEL decides NOT to resort for RA, Price Bids and Price-Impacts, if any, already submitted by Bidder and available with BHEL, shall be opened, as detailed under Point 4 above.**
- J. **Information and General Terms and Conditions governing RA, are detailed below**

Against this enquiry for the subject item/ system with detailed scope of supply as per enquiry specifications, BHEL may resort to "REVERSE AUCTION PROCEDURE" i.e., ON LINE BIDDING (THROUGH A SERVICE PROVIDER). The philosophy followed for reverse auction shall be English Reverse (No ties).

Annexure-A

Important Note to Tenderers - for TWO BID system (including REVERSE AUCTION)

(Page No. 4 of 4)

1. For the proposed reverse auction, technically and commercially acceptable bidders only shall be eligible to participate.
2. Those bidders who have given their acceptance for Reverse Auction (quoted against this tender enquiry) will have to necessarily submit, online sealed bid in the Reverse Auction. Non-submission of „online sealed bid“ by the bidder for any of the eligible items for which techno commercially qualified, will be considered as tampering of the tender process and will invite action by BHEL as per extant guidelines in vogue.
3. BHEL will engage the services of a service provider who will provide all necessary training and assistance before commencement of on line bidding on internet.
4. In case of reverse auction, BHEL will inform the bidders the details of Service Provider to enable them to contact & get trained.
5. Business rules like event date, time, bid decrement, extension etc. also will be communicated through service provider for compliance.
6. Bidders have to fax the Compliance form (annexure IV) before start of Reverse auction. Without this, the bidder will not be eligible to participate in the event.
7. In line with the NIT terms, BHEL will provide the calculation sheet (e.g., EXCEL sheet) which will help to arrive at “Total Cost to BHEL” like Packing & forwarding charges, Taxes and Duties, Freight charges, Insurance, Service Tax for Services and loading factors (for noncompliance to BHEL standard Commercial terms & conditions) for each of the bidder to enable them to fill-in the price and keep it ready for keying in during the Auction.
8. Reverse auction will be conducted on scheduled date & time.
9. At the end of Reverse Auction event, the lowest bidder value will be known on auction portal.
10. The lowest bidder has to fax/e-mail the duly signed and filled-in prescribed format for price breakup including that of line items, if required, (Annexure VII) as provided on case-to-case basis to Service provider within two working days of Auction without fail.
11. In case BHEL decides not to go for Reverse Auction procedure for this tender enquiry, the Price bids and price impacts, if any, already submitted and available with BHEL shall be opened as per BHEL s standard practice.
12. Bidders shall be required to read the “Terms and Conditions” section of the auctions site of Service provider, using the Login IDs and passwords given to them by the service provider before reverse auction event. Bidders should acquaint themselves of the „Business Rules of Reverse Auction“, which will be communicated before the Reverse Auction.
13. If the Bidder or any of his representatives are found to be involved in Price manipulation/ cartel formation of any kind, directly or indirectly by communicating with other bidders, action as *per extant BHEL guidelines*, shall be initiated by BHEL and the results of the RA scrapped/ aborted.
14. The Bidder shall not divulge either his Bids or any other exclusive details of BHEL to any other party.
15. In case BHEL decides to go for reverse auction, the H1 bidder (whose quote is highest in online sealed bid) may not be allowed to participate in further RA process.

KINDLY PROVIDE FOLLOWING INFORMATION, IN CASE OF REVERSE AUCTION TO BE CONDUCTED

NAME OF THE PERSON:

MOBILE NO. :

LAND LINE NO. :

FAX NO. :

EMAIL ID :

.....oo0oo.....

Annexure – B.
PAYMENT TERMS

Vendor Code:	Vendor Name:	
Tender No.:	Tender Date:	Tender Due Date:

IMPORTANT NOTE TO SUPPLIERS:

If materials are receivable at Stores/Trichy <u>without PBG</u>	Payment term is 100% direct payment after 45 days from the date of receipt and acceptance of materials.
If materials are receivable at Stores/Trichy <u>with PBG</u>	Payment term is 100% direct payment after 45 days from the date of receipt and acceptance of materials and against 10% PBG valid for the warranty period.
Any deviation in the above payment term will attract loading as mentioned below. “Base rate of SBI (as applicable on the date of Techno-commercial bid opening) + 6% will be loaded for the period of relaxation sought by bidders.	

Payment through bank	Payment through Bank is not preferred. In case of Payment through Bank is opted by Supplier, BHEL prefers documents submission through bank with copy of LR and door delivery of Goods to Site/Stores with Consignee copy attached. In this case Loading will be 3% on the offered value. Offers of indigenous Suppliers with payment terms as LC/Advance Payment are liable for rejection.
-----------------------------	--

Liquidated Damages / Penalty

- a. Liquidated damages shall be 0.5% of the total order value per week or part thereof subject to a maximum of 10% of the total order value.
- b. For staggered delivery schedule, LD shall be 0.5% of the undelivered portion per week of the delay or part thereof subject to a maximum of 10% of the total order value.
- c. Any deviation from the above LD clause, loading will be applied to the extent to which it is not agreed by the bidder (at offered value).

Guarantee / Warranty Period

Normally No deviation permitted and the deviated offers are liable for rejection.

Performance Bank Guarantee

Normally No deviation permitted and the deviated offers are liable for rejection.

BHEL will consider the ranking after the loading is applied as referred above wherever deviations are observed.

Annexure – C.
Commercial Conditions

Vendor Code:	Vendor Name:		
Tender No.:	Tender Date:	Tender Due Date:	

Sl. No.	Commercial Terms	Accepted	If Not accepted , give details
C 1.	<u>Delivery Terms:</u> Free delivery at BHEL/SSTP Stores. (including Packing, Forwarding, Freight and Insurance charges)		
C 2.	<u>Payment term :</u> 100% direct payment after 45 days from the date of receipt and acceptance of materials		
C 3.	Liquidated damages @ ½% per week subject to maximum of 10% of the order value shall be applicable for delay in deliveries		
C 4.	<u>Delivery:</u>	<u>indicate no. of weeks</u>	
C 5.	<u>Validity of Offer</u> - 60 Days from the Date of Tender Opening.		
C 6.	<u>Guarantee certificate:</u> shall cover total period of 18 months from date of dispatch or 12 months from the date of actual usage of the material whichever is earlier		
C 7.	<u>Erection and Commissioning(if applicable)</u> Erection / commissioning charges if any has to be mentioned in the offer or else it will be assumed that Erection/ commissioning will be done at free of cost	<u>Pl indicate applicability</u>	
Remarks, if any (attach additional sheet, if required) :			

Sl. No.	Commercial Terms	Vendor to fill in
C 8.	a. Excise Duty Tariff Heading	
	b. Excise Duty (%)	
	c. CESS on ED (%)	
	d. Total of ED and CESS (%)	
C 9.	a. TVNAT (%)	
	b. CST (%)	
C 10.	Other Cost (if any) - % (or) Rs.	
C 11.	Are you Micro/Small/Medium Industry?	Yes / No.
	If YES, please furnish MSM Regn. No. along with a copy of MSM Certificate	MSM No. : MSM Certificate Enclosed : Yes / No

Signature with Date	Seal

Certificate by Chartered Accountant

This is to Certify that M/S,
(hereinafter referred to as 'company') having its registered office at
..... is registered under MSMED Act 2006, (Entrepreneur
MeMemorandum No (Part—II)..... dtd:.....,
Category:..... (Micro/Small)). (Copy enclosed).

Further verified from the Books of Accounts that the investment of the company as on
date as per MSMED Act 2006 is as follows:

1. **For Manufacturing Enterprises: Investment in plant and machinery** (i.e. original cost
excluding land and building and the items specified by the Ministry of Small Scale Industries vide its
notification No.5.0.1722(E) dated October 5, 2006:
Rs.Lacs
2. **For Service Enterprises: Investment in equipment** (original cost excluding land and building and
furniture, fittings and other items not directly related to the service rendered or as may be notified under the MSMED
Act, 2006:
Rs.Lacs

The above investment of Rs..... Lacs is within permissible limit of
RsLacs for Micro / Small (~~Strike off which is not applicable~~)
Category under MSMED Act 2006.

Date:

(Signature)

Name -

Membership number -

Seal of Chartered Accountant