



Bharat Heavy Electricals Limited
(Seamless steel Tube Plant)
Tiruchirappalli – 620014, TAMIL NADU, INDIA

TITLE: SUPPLY OF FASTENING PLATE & TROUGH – 3 Items	Phone: +91 431 257 8428 Email : rbmurugan@bheltry.co.in Web : www.bhel.com
--	---

Reference Number: 9440549E	Date: 22.04.2014	Due date for submission of application: 12.05.2014
-----------------------------------	-------------------------	---

BHEL/SSTP, Trichy is looking for vendors to supply of FASTENING PLATE & TROUGH – 3 Items as per Tender documents attached.

A. Important Note to New Vendors

The new vendors will be required to furnish the following documentary proof/ information along with their offers:

1. Certificate of registration (copy of certificate to be submitted).
2. Banker's information (copy of bank pass book first page to be submitted).
3. MSME vendor certificate (if applicable).
4. Address of your organization (complete postal address with PINCODE).
5. Contact person's Phone No. /Mobile No. / FAX No. /E-mail ID.
6. Statutory documents – VAT / TIN / EXCISE REGISTRATION / CST REGN / SERVICE TAX REGISTRATION etc. (copy to be furnished)
7. NSIC/SSI Certificate (if applicable)
8. ISO Certificate (if applicable)
9. Experience certificate as proof of supply of similar items to any Govt. agencies / PSU / Organisations (copy of PO's to be furnished).
10. Audit Report/ IT Return (if applicable)
11. Agency agreement with manufacturer (if applicable)
12. Partnership Deed (if applicable).

If the new vendors fail to submit the above documentary proof/information, their offers will not be considered for this enquiry.



Bharat Heavy Electricals Limited
(Seamless steel Tube Plant)
Tiruchirappalli – 620014, TAMIL NADU, INDIA

B) Important Note to MSE Vendors

1. 20% of the tendered quantity is earmarked for MSE suppliers in this tender.
2. Out of the 20% tendered quantity reserved for MSE suppliers, 4% shall be earmarked for procurement from MSE owned by SC / ST entrepreneurs.
3. In case MSE vendor participating in the tender quotes within the price band of L1 + 15%, they will be allowed to supply the portion of the requirement subject to acceptance of L1 price by MSE vendor. In case of more than one such MSE, the supply shall be shared proportionately.
4. MSE suppliers can avail the intended benefits only if they submit along with offer, attested copies of either EM II certificate having deemed validity (Two years from the date of issue of acknowledgement in EM II) or valid NSIC certificate or EM II certificate along with CA certificate (Format enclosed) applicable for the year, certifying quantum of investment in plant and machinery within the permissible limit as per the act for relevant status (Micro or small) where the deemed validity of EM IIIs over. Date to be reckoned for determining the deemed validity will be the last date of technical bid submission. Non submission of such documents will lead to consideration of their bids at par with other bidders and MSE status of such suppliers shall be shifted to Non MSE supplier till the supplier submits these documents.

Sr.Manager / Purchase /SSTP
Phone: 0431-257 8428.
Mail: rbmurugan@bheltry.co.in



BHARAT HEAVY ELECTRICALS LIMITED
(A GOVERNMENT OF INDIA UNDERTAKING)
SEAMLESS STEEL TUBE PLANT
TIRUCHIRAPALLI - 620 014.
TAMILNADU (INDIA)

PHONE : 0431-2578480/8491
: 0431-2578406/8419
: 0431-2578568
FAX : 0431-2576828

TIN : 33243560005

CST. No. : 239383

Dated : 11.06.1991

PURCHASE ENQUIRY

VENDOR CODE

19441

ENQUIRY NUMBER

9440549E

ENQUIRY DATE

22/04/2014

ENQUIRY DUE DATE

12/05/2014

No. OF ITEM

03

Office Copy

IMPORTANT POINTS :

1. Tender Closing Time : 14.00 Hrs.
2. Tender Opening Time : 15.00 Hrs.
3. Tender should be submitted in a sealed cover, duly indicating enquiry No. Enquiry date & Enquiry Due Date on the cover.
4. Offer(s) received through Courier Services after 14.00 Hrs. on Enquiry Due Date will not be considered.
5. Late Tender(s) is/are liable for rejection.
6. Offer(s) shall be valid for 60 days from Enquiry Due Date.
7. Offer(s) in Vendor's Letter head shall contain.
 - a. Offer No. and Date
 - b. Delivery Period
 - c. Delivery Terms
 - d. Payment Terms
 - e. Excise Duty with Tariff Heading Sales Tax (against form-XVII/Form-C), etc.
 - f. Excise Regn. No. and SSI Regn. No.

Kindly arrange to submit your **COMPETITIVE OFFER** for the following item(s)
If you are not in a position to submit your Offer, kindly arrange to send your **REGRET LETTER**.

THIS IS ONLY A REQUEST FOR OFFER AND NOT AN ORDER

Sl.No.	BHEL Material Code and Description	Unit	Requirement	
			Quantity	Delivery
01	BHEL Material Code : SP9115810334 ----- FASTENING PLATE TYPE:FIXED DRG.NO:3-7-1158-01-10153 MATL:C.S Gr.250-300 IS:1030	Nos.	01 5.000	30/08/2014
02	BHEL Material Code : SP9112742308 ----- TROUGH DRG.NO:1-9-1127-04-00152 MATL :S355 JRG2 NOTE:MANUFACTURING INSTRUCTION SN200	Nos.	01 1.000	30/08/2014
03	BHEL Material Code : SP9112742307 ----- TROUGH DRG.NO:1-9-1127-04-00151 MATL :S355 JRG2 NOTE:MANUFACTURING INSTRUCTION:SN200	Nos.	01 1.000	30/08/2014
Foot Note :: ----- THIS TENDER IS CALLED ON TWO BID SYSTEM.KINDLY REFER THE ANNEXURE-A & C ATTACHED. CONFIRM THE FOLLOWING COMMERCIAL POINTS WITHOUT FAIL: ----- 1.OUR STD PAYMENT TERMS IS 100 % PYT WITH IN 45 DAYS ON RECEIPT AND ACCEPTANCE OF MATERIALS THRO E-PAYMENT.FORMAT WILL BE SENT ALONG WITH PUR ORDER. 2.INSPECTION WILL BE CARRIED OUT AT YR WORKS PRIOR TO DESPATCH BY BHEL.FOR WHICH ONE WEEK ADVANCE INTIMATION IS TO BE GIVEN ON READINESS OF MATERIAL.				

IMPORTANT NOTE :

1. Delivery Terms : "Free Delivery at BHEL-SSTP STORES" is preferable.
2. Payment Terms : 100% payment after 45 days after receipt and acceptance of materials by BHEL.
3. Terms and Conditions of Tender : Please see reverse.
4. The Technical Requirements/Specification Details/Quality Requirements/Commercial Terms & Conditions are clearly furnished in the Tender. If Deviation(s) is/are not explicitly brought out in the Offer, it will be construed that the Tenderer is complying with the requirement of BHEL in full without any deviation(s).

For and on behalf of

BHARAT HEAVY ELECTRICALS LTD.

(Signature)

PURCHASE EXECUTIVE



BHARAT HEAVY ELECTRICALS LIMITED
 (A GOVERNMENT OF INDIA UNDERTAKING)
 SEAMLESS STEEL TUBE PLANT
 TIRUCHIRAPALLI - 620 014.
 TAMILNADU (INDIA)

PHONE : 0431-2578480/8491
 : 0431-2578406/8419
 : 0431-2578568
 FAX : 0431-2576828

TIN : 33243560005
 CST. No. : 239383
 Dated : 11.06.1991

PURCHASE ENQUIRY

VENDOR CODE 19441	ENQUIRY NUMBER 9440549E	ENQUIRY DATE 22/04/2014	ENQUIRY DUE DATE 12/05/2014	No. OF ITEMS 03
----------------------	----------------------------	----------------------------	--------------------------------	--------------------

Office Copy

- IMPORTANT POINTS :**
1. Tender Closing Time : 14.00 Hrs.
 2. Tender Opening Time : 15.00 Hrs.
 3. Tender should be submitted in a sealed cover, duly indicating enquiry No. Enquiry date & Enquiry Due Date on the cover.
 4. Offer(s) received through Courier Services after 14.00 Hrs. on Enquiry Due Date will not be considered.
 5. Late Tender(s) is/are liable for rejection.
 6. Offer(s) shall be valid for 60 days from Enquiry Due Date.
 7. Offer(s) in Vendor's Letter head shall contain,
 - a. Offer No. and Date
 - b. Delivery Period
 - c. Delivery Terms
 - d. Payment Terms
 - e. Excise Duty with Tariff Heading Sales Tax (against form-XVII/Form-C), etc.
 - f. Excise Regn. No. and SSI Regn. No.

Kindly arrange to submit your COMPETITIVE OFFER for the following item(s)
 If you are not in a position to submit your Offer, kindly arrange to send your REGRET LETTER.

THIS IS ONLY A REQUEST FOR OFFER AND NOT AN ORDER

Sl.No.	BHEL Material Code and Description	Unit	Requirement	
			Quantity	Delivery
	3.PL QUOTE THE RATE ON DOOR DELIVERY BASIS DULY INCLUDING PKG, FORWARDING, FREIGHT AND INSURANCE CHARGES.			
	4.TEST CERTIFICATES FOR MATERIAL CHEMICAL COMPOSITION TO BE SUBMITTED ALONG WITH SUPPLIES.			
	5.PERFORMANCE BANK GUARANTEE FOR 10 % ON BASIC VALUE IS TO BE SUBMITTED WHILE RELEASING PAYMENT.			
	6.CONFIRM YR ACCEPTANCE FOR LD AND RISK PURCHASE CLAUSES.			

IMPORTANT NOTE :
 Delivery Terms : "Free Delivery at BHEL-SSTP STORES" is preferable.
 Payment Terms : 100% payment after 45 days after receipt and acceptance of materials by BHEL.
 Terms and Conditions of Tender : Please see reverse.
 The Technical Requirements/Specification Details/Quality Requirements/Commercial Terms & Conditions are clearly furnished in the Tender. If Deviation(s) is/are not explicitly brought out in the Offer, it will be construed that the Tenderer is complying with the requirement of BHEL in full without any deviation(s).

For and on behalf of
BHARAT HEAVY ELECTRICALS LTD.

PURCHASE EXECUTIVE

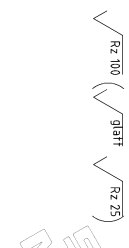
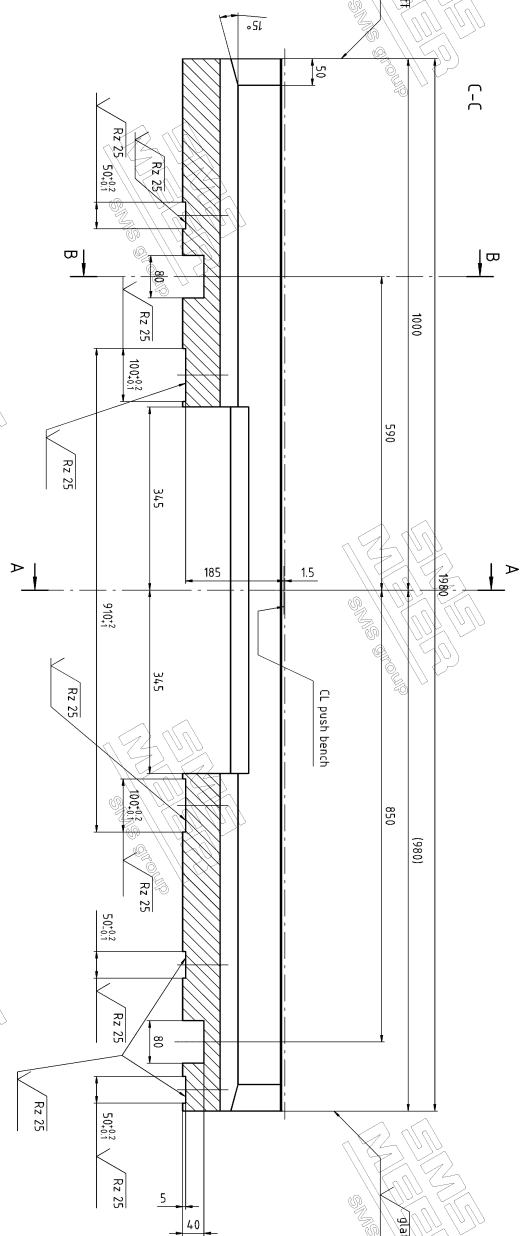
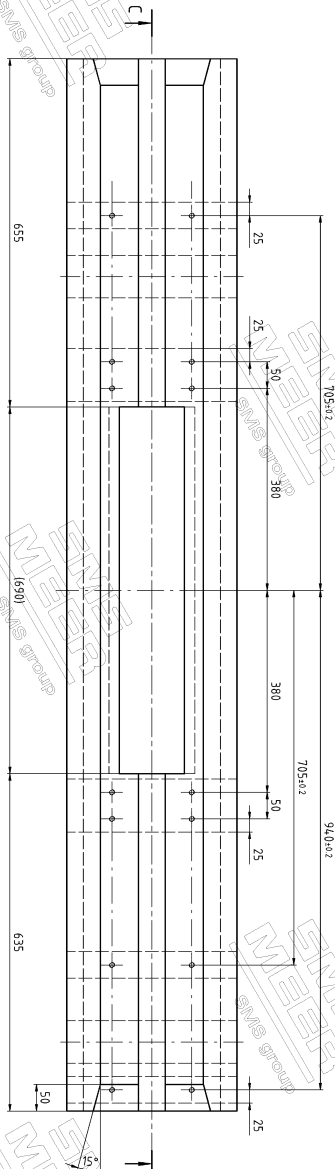
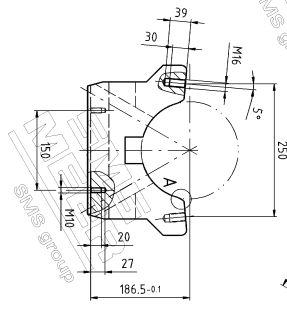
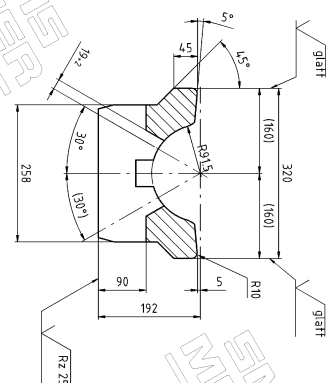
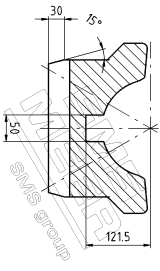

Part description		Drawing / design		Material	
Verarbeitungsverfahren SN 200		Verarbeitungsverfahren S355 JR62		Material S355 JR62	
Revision		Date		Drawing No. 0115.019-42.308	
Author		Date		Drawing No. 0115.019-42.308	
Designer		Date		Drawing No. 0115.019-42.308	
Checker		Date		Drawing No. 0115.019-42.308	
Approver		Date		Drawing No. 0115.019-42.308	
Release		Date		Drawing No. 0115.019-42.308	
Drawing No. 0115.019-42.308		Drawing No. 0115.019-42.308		Drawing No. 0115.019-42.308	
Drawing No. 0115.019-42.308		Drawing No. 0115.019-42.308		Drawing No. 0115.019-42.308	
Drawing No. 0115.019-42.308		Drawing No. 0115.019-42.308		Drawing No. 0115.019-42.308	

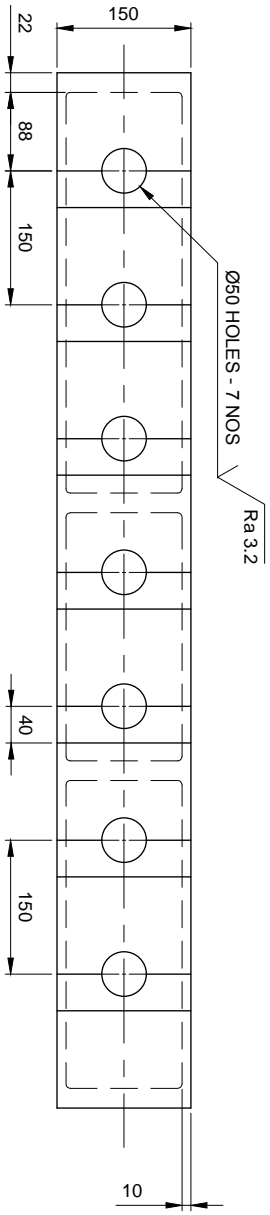
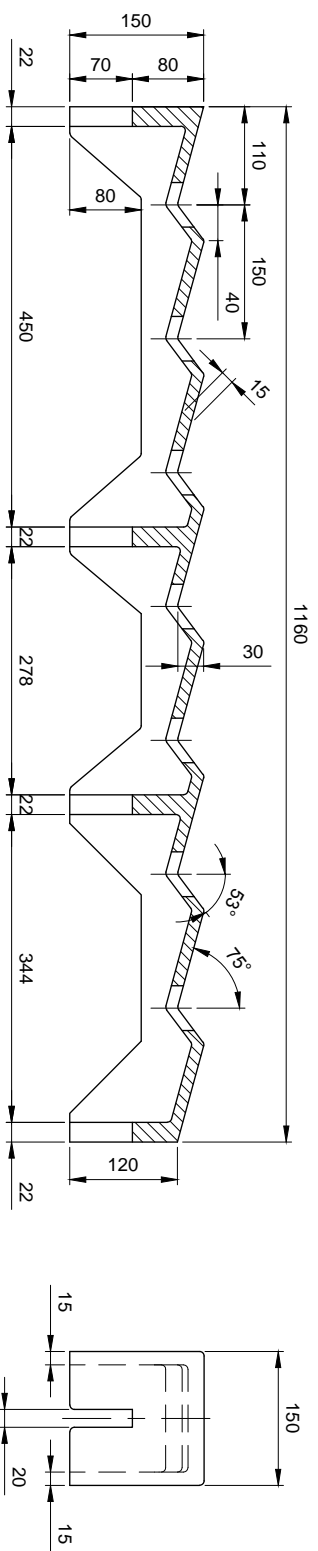
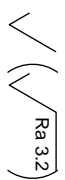

LIFTING WEIGHT - 50 Kg

CAUTION: THE INFORMATION ON THIS DOCUMENT IS THE PROPERTY OF BHARAT HEAVY ELECTRICALS LIMITED. IT MUST NOT BE USED DIRECTLY OR INDIRECTLY IN ANY WAY DETRIMENTAL TO THE INTEREST OF THE COMPANY.

REV	DATE	ALTERED
01		CHECKED APPROVED

DEPT	GRADE OF UNITOL. DIM	SCALE	WEIGHT (Kg)
SSTP	ϕ / \sqrt{M} / \sqrt{F}	1:1	19
CODE	IS:2102		

ITEM NO	DESCRIPTION	DRAWING NO	UNIT WT	QTY
			C.S GR 250 - 300 IS:1030	1
			MATL CODE	
			MATL SPEC	

DRN	NAME	SIGNATURE	DATE
R.RAGHUVIEER/S,RN	R. Raghuvieer/S.RN	<i>R. Raghuvieer/S.RN</i>	22.02.14
G.LOGANATHAN	G. Loganathan	<i>G. Loganathan</i>	22.02.14
M.CHANDRAKUMAR	M. Chandrakumar	<i>M. Chandrakumar</i>	22.02.14

APPD	REF TO ASSY DWG NO	REF TO OLD DWG NO
M.CHANDRAKUMAR	TAT764.01.00AZ	TAT764.01.03AZ

TITLE	CARD CODE	DRAWING NO :	REV
WBC - FASTENING PLATE	U 01	3-7-1158-01-10153	00
FIXED RACK ASSY.			

Annexure-A

Important Note to Tenderers

This Tender is floated on TWO-BID System. Tenders are requested to submit their offers in TWO-BIDS (Part I: Un priced bid and Part II: Price Bid) separately in a sealed cover as follows.

1. **Part I: UN PRICED BID:** (Complete with technical & Commercial conditions as per enquiry including un priced copy of price schedule i.e. identical to part II with prices blanked and replaced by "Quoted")
The Tenderer should confirm their acceptance / comments to each and every clause of Annexure-A to Enquiry along with other commercial Terms & Conditions of Tender. In case any deviation is taken by the Tenderer from the Tender requirements, it is to be clearly indicated in the offer with reference to the particular clause. If such deviations are not explicitly indicated in the offer, it will be construed by BHEL that the Tenderer is complying with Annexure Clause(s), Commercial terms & conditions and other conditions in full. Any such non-compliance on these points, if raised / highlighted by the Tenderer, after opening the Price Bid, it will not be accepted by BHEL and the tender evaluation will be done based on the original offer submitted by them.
2. **Part II: PRICE BID:** Price (with break-up details wherever required) alone to be indicated. Price bid shall **not** contain any technical and commercial details.
3. **Both Un priced Bid and Price Bid is** to be submitted in a single envelop before 14.00 hours (Indian Time) on tender Due Date.
4. The **Unpriced Bid** shall be put in a separate sealed cover superscribed with Tender number, Tender Date & Tender Due Date and also the cover should be clearly marked with "UNPRICED BID".
5. The **Price Bid** shall be put in a separate sealed cover superscribed with Tender number, Tender Date & Tender Due Date & the cover should be clearly marked with "PRICE BID".
6. Both the individually enveloped **UNPRICED BID** and **PRICE BID** covers as mentioned above, have to be put in another single bigger cover clearly indicating Tender number, Tender Date & Tender Due Date at the top of the cover. This cover is to be addressed to Purchase Executive, Purchase Department, Seamless Steel Tube Plant (SSTP), BHEL, Tiruchirapalli-620014, India.
7. Unpriced Bid shall only be opened on the Tender Due Date mentioned in the Tender, in the presence of Tenderers / their Authorized Representative, who may like to be present for such opening. The price bid will NOT be opened on the date of tender opening.
8. After opening the Unpriced Bid, they shall be evaluated by BHEL for their suitability. BHEL shall hold discussions with the responded Tenderers on the Technical and Commercial terms and freeze the technical specifications. These frozen technical specifications will be communicated to responded tenderers.
9. BHEL shall offer opportunity to the responded and technically / commercially suitable Tenderers, to submit their latest Price Bid in line with the frozen technical delivery conditions.
10. This latest Price Bid for the frozen technical specifications submitted by the Tenderers will be opened in the presence of those Tenderers who have submitted the latest Price Bid. Based on the latest Price Bid only, the ranking of the Tenderers shall be made and accordingly the Tender shall be finalized.

Annexure – C.
Commercial Conditions

Vendor Code:	Vendor Name:	
Tender No.:	Tender Date:	Tender Due Date:

Sl.No	Commercial Terms	Accepted
C1.	<u>Delivery Terms :</u> Free delivery at BHEL/SSTP Stores duly including Packing, Forwarding, Freight and Insurance charges	
C2.	<u>Payment :</u> 100% after 45 days after receipt and acceptance of materials by BHEL	
C3.	<u>LIQUIDATED DAMAGES:</u> It is clearly understood among the parties to the Contract that TIME IS THE ESSENCE OF THE CONTRACT. Therefore, the delivery of the goods specified in the Purchase Order shall be made within the time prescribed. Where the Seller supplies or despatches the goods, beyond the delivery period specified, and the Purchaser will have no obligation to accept the goods. If accepted, Liquidated Damages at the rate of 0.5% (Zero point five Percent) of the value of goods delayed, per week of delay, subject to a maximum of 10% (Ten Percent) or part thereof, will be levied without prejudice to any other relief or compensation due to the Purchaser under any other conditions of the Contract. <u>RISK PURCHASE:</u> Alternatively, the Purchaser, at his option, will be entitled to terminate the Contract and to purchase elsewhere at the risk and cost of Seller, either the whole of the goods or any part, which the Seller has failed to deliver or dispatch within the time stipulated as aforesaid or if the same were not available the best and nearest available substitute thereof. The Seller shall be liable for any loss, which the Purchaser may sustain by reason of such Risk Purchase(s), in addition to penalty at the rate mentioned in Clause No.06 above.	
C4.	<u>Delivery Period :</u> As per Enquiry schedule.	
C5.	<u>Validity – minimum 60 Days from the date of Tender Opening.</u>	
<u>Deviations if any (attach additional sheet, if required) :</u>		

Sl.No.	Commercial Terms	
C6.	Validity of Offer (Date)	
C7.	Excise Duty (including Cess) % (with Break up details)	
C8.	TVNAT / CST (%)	
C9.	Delivery Period (Days/Weeks/Months) Please refer the Enquiry.	
C10.	Other Cost (if any) - % (or) Rs.	
C11.	Are you Micro/Small/Medium Industry? (If YES, please furnish MSM Regn.No., along with a copy of MSM Certificate)	YES / NO MSM No. MSM Certificate enclosed(Yes/NO)

Signature with Date :

Respective procurement Groups shall incorporate the applicable conditions in the NIT for Indigenous and Imports separately.

Payment Term (Indigenous)	
If materials are receivable at Stores/Trichy <u>without PBG</u>	Payment term is 100% direct payment after 45 days from the date of receipt and acceptance of materials.
If materials are receivable at Stores/Trichy <u>with PBG</u>	Payment term is 100% direct payment after 45 days from the date of receipt and acceptance of materials and against 10% PBG valid for the warranty period.
Any deviation in the above payment term will attract loading as mentioned below. “Base rate of SBI (as applicable on the date of bid opening. Techno-commercial bid opening in case of two part bids) + 6% shall be considered for loading for the period of relaxation sought by bidders.	

Payment Term (Indigenous)	
If materials are receivable at Project Sites without PBG	Option-1: Payment term is 100% direct payment after 45 days from the date of dispatch against site acknowledgement Option-2: Payment term is 90% direct payment after 45 days from the date of dispatch against submission of dispatch documents and balance 10% against site acknowledgement. For this option -2, a loading of 2% on the 90% of the offered value shall be made.
If materials are receivable at Project Sites with PBG	Option-1: Payment term is 100% direct payment after 45 days from the date of dispatch against site acknowledgement and against 10% PBG valid for the warranty period. Option-2: Payment term is 90% direct payment after 45 days from the date of dispatch against submission of dispatch documents and 10% PBG valid for the warranty period and balance 10% against site acknowledgement. For this option -2, a loading of 2% on the 90% of the offered value shall be made.

To be incorporated in all NITs addressed to Indigenous Suppliers	Payment through Bank is not preferred. In case of Payment through Bank is opted by Supplier, BHEL prefers documents submission through bank with copy of LR and door delivery of Goods to Site/Stores with Consignee copy attached. In this case Loading will be 3% on the offered value. In case of Direct to Site (DTS), only 90% through bank will be considered.
	Offers of indigenous Suppliers with payment terms as LC/Advance Payment are liable for rejection.

Payment Term (Imports) - To be incorporated in all NITs addressed to Import Suppliers

BHEL Payment term is 100% payment on CAD basis after 45 days from the date of receipt of documents, specified in PO, at BHEL bank. Respective bank charges to respective account.

Any deviation in the above payment term will attract loading as mentioned below. “Base rate of SBI (as applicable on the date of bid opening. Techno-commercial bid opening in case of two part bids) + 6% shall be considered for loading for the period of relaxation sought by bidders.

In the case of Usance LCs the loading will be considered @ 1.5% on the offered Value.

For LC at sight the loading will be considered @ 3.5% on the offered Value.

Normally CAD at sight and Confirmed LCs are liable for rejection.

Liquidated Damages / Penalty - To be incorporated in all NITs addressed to both Indigenous and Import Suppliers

Liquidated damages shall be 0.5% of the total order value per week or part thereof subject to a maximum of 10% of the total order value.

For staggered delivery schedule, LD shall be 0.5% of the undelivered portion per week of the delay or part thereof subject to a maximum of 10% of the total order value.

Any deviation from the above LD clause, loading will be applied to the extent to which it is not agreed by the bidder (at offered value).

Guarantee / Warranty Period - To be incorporated in all NITs addressed to both Indigenous and Import Suppliers

Normally No deviation permitted and the deviated offers are liable for rejection.

Performance Bank Guarantee - To be incorporated in all NITs addressed to both Indigenous and Import Suppliers

Normally No deviation permitted and the deviated offers are liable for rejection.

To be incorporated in all NITs addressed to both Indigenous and Import Suppliers

BHEL will consider the ranking after the loading is applied as referred above wherever deviations are observed.

Certificate by Chartered Accountant

This is to Certify that M/S,
(hereinafter referred to as 'company') having its registered office at
..... is registered under MSMED Act 2006, (Entrepreneur
MeMemorandum No (Part—II).....dtd:.....,
Category:..... (Micro/Small)). (Copy enclosed).

Further verified from the Books of Accounts that the investment of the company as on
date as per MSMED Act 2006 is as follows:

1. **For Manufacturing Enterprises: Investment in plant and machinery** (i.e. original cost
excluding land and building and the items specified by the Ministry of Small Scale Industries vide its
notification No.5.0.1722(E) dated October 5, 2006:
Rs.Lacs
2. **For Service Enterprises: Investment in equipment** (original cost excluding land and building and
furniture, fittings and other items not directly related to the service rendered or as may be notified under the MSMED
Act, 2006:
Rs.Lacs

The above investment of Rs..... Lacs is within permissible limit of
RsLacs for Micro / Small (~~Strike off which is not applicable~~)
Category under MSMED Act 2006.

Date:

(Signature)

Name -

Membership number -

Seal of Chartered Accountant