



**Bharat Heavy Electricals Limited**  
**(Seamless steel Tube Plant)**  
Tiruchirappalli – 620014, TAMIL NADU, INDIA

<b>TITLE:</b> <b>SUPPLY OF CHARGING ROLLER ASSEMBLY</b>	Phone: +91 431 257 8439 Email : pcsn@bheltry.co.in Web : <a href="http://www.bhel.com">www.bhel.com</a>
--	---

<b>Reference Number: 9440577E</b>	<b>Date: 06.05.2014</b>	<b>Due date for submission of application: 27.05.2014</b>
-----------------------------------	-------------------------	---

**BHEL/SSTP, Trichy is looking for vendors to supply of CHARGING ROLLER ASSEMBLY as per Tender documents attached.**

**A. Important Note to New Vendors (Viewers thro' web site)**

The new vendors will be required to furnish the following documentary proof/ information along with their offers:

1. Certificate of registration (copy of certificate to be submitted).
2. Banker's information (copy of bank pass book first page to be submitted).
3. MSME vendor certificate (if applicable).
4. Address of your organization (complete postal address with PINCODE).
5. Contact person's Phone No. /Mobile No. / FAX No. /E-mail ID.
6. Statutory documents – VAT / TIN / EXCISE REGISTRATION / CST REGN / SERVICE TAX REGISTRATION etc. (copy to be furnished)
7. NSIC/SSI Certificate (if applicable)
8. ISO Certificate (if applicable)
9. Experience certificate as proof of supply of similar items to any Govt. agencies / PSU / Organisations (copy of PO's to be furnished).
10. Audit Report/ IT Return (if applicable)
11. Agency agreement with manufacturer (if applicable)
12. Partnership Deed (if applicable).

**If the new vendors fail to submit the above documentary proof/information, their offers will not be considered for this enquiry.**

**"MSE suppliers can avail the intended benefits only if they submit along with offer, attested copies of either EM II certificate having deemed validity (Two years from the date of issue of acknowledgement in EM-II) or valid NSIC certificate or EM II certificate along with CA certificate (Format enclosed ) applicable for the year,**



An ISO 9001  
Company

## **Bharat Heavy Electricals Limited** **(Seamless steel Tube Plant)**

Tiruchirappalli – 620014, TAMIL NADU, INDIA

**certifying quantum of investment in plant and machinery within the permissible limit as per the act for relevant status (Micro or small) where the deemed validity of EM II is over. Date to be reckoned for determining the deemed validity will be the last date of bid submission. Non submission of such documents will lead to consideration of their bids at par with other bidders and MSE status of such suppliers shall be shifted to Non MSE supplier till the supplier submits these documents".**

Purchase Officer / Purchase /SSTP

Phone: 0431-257 8440.

Mail: [neerajxalxo@bheltry.co.in](mailto:neerajxalxo@bheltry.co.in)



**BHARAT HEAVY ELECTRICALS LIMITED**  
 (A GOVERNMENT OF INDIA UNDERTAKING)  
 SEAMLESS STEEL TUBE PLANT  
 TIRUCHIRAPALLI - 620 014.  
 TAMILNADU (INDIA)

PHONE : 0431-2578480/8491  
 : 0431-2578406/8419  
 : 0431-2578568  
 FAX : 0431-2576828

TIN : 33243560005

CST. No. : 239383  
 Dated : 11.06.1991

**PURCHASE ENQUIRY**

VENDOR CODE  
 23009

ENQUIRY NUMBER  
 9440577E

ENQUIRY DATE  
 06/05/2014

ENQUIRY DUE DATE  
 27/05/2014

No. OF ITEMS  
 01

Office Copy

**IMPORTANT POINTS :**

1. Tender Closing Time : 14.00 Hrs.
2. Tender Opening Time : 15.00 Hrs.
3. Tender should be submitted in a sealed cover, duly indicating enquiry No. Enquiry date & Enquiry Due Date on the cover.
4. Offer(s) received through Courier Services after 14.00 Hrs. on Enquiry Due Date will not be considered.
5. Late Tender(s) is/are liable for rejection.
6. Offer(s) shall be valid for 60 days from Enquiry Due Date.
7. Offer(s) in Vendor's Letter head shall contain.
  - a. Offer No. and Date
  - b. Delivery Period
  - c. Delivery Terms
  - d. Payment Terms
  - e. Excise Duty with Tariff Heading Sales Tax (against form-XVII/Form-C). etc.
  - f. Excise Regn. No. and SSI Regn. No.

Kindly arrange to submit your COMPETITIVE OFFER for the following item(s)  
 If you are not in a position to submit your Offer, kindly arrange to send your REGRET LETTER.

**THIS IS ONLY A REQUEST FOR OFFER AND NOT AN ORDER**

No.	BHEL Material Code and Description	Unit	Requirement	
			Quantity	Delivery
01	<p>BHEL Material Code : SP9115011201</p> <p>-----</p> <p>CHARGING ROLLER ASSEMBLY AS PER            DRG.NO :1-7-1150-10-10003 Rev01</p> <p>CONSISTING OF THE FOLLOWING COMPONENTS            IN ASSEMBLED CONDITION:</p> <p>1.CHARGE ROLLER            DRG.NO:1-7-1150-00-10001Rev01            MATL.HK ALLOY (25% Cr,20% Ni)</p> <p>2.PIPE ASSY            ITEM NO.2            DRG.NO:1-7-1150-10-10002 Rev01            MATL.SS 304</p> <p>3.SHAFT            ITEM NO.3            DRG.NO:1-7-1150-10-10002Rev01            MATL.SS 304</p> <p>4.PLATE            ITEM NO.4            DRG.NO:1-7-1150-10-10002Rev01            MATL.SS310</p>	Set	01 10.000	08/07/2014
	<p>Foot Note ::</p> <p>-----</p> <p>1)THE ROLLER CASTINGS SHOULD BE OF HEAT RESISTANT ALLOY STEEL AND NICKEL BASED CASTINGS, IS:4522-1986GR.9</p> <p>2)TEST CERTIFICATE FOR CHEMICAL COMPOSITION,TENSILE TESTING,HARDNESS AND DIMENSION SHOULD BE PRODUCED ALONG WITH THE SUPPLY.</p> <p>3)ROLLER CASTINGS HAS TO BE SUPPLIED WITHOUT ANY DEFECTS LIKE BLOW HOLES,CRACKS AND POROSITY.</p> <p>4)INSPECTION OF ROLLER ASSEMBLY WILL BE DONE BY BHEL/SSTP AT YOUR WORKS BEFORE DESPATCH, FOR WHICH 15 DAYS ADVANCE INTIMATION TO BE GIVEN ALONG WITH YOUR INSPECTION REPORT.</p>			

**IMPORTANT NOTE :**

Delivery Terms : "Free Delivery at BHEL-SSTP STORES" is preferable.  
 Payment Terms : 100% payment after 45 days after receipt and acceptance of materials by BHEL.  
 Terms and Conditions of Tender : Please see reverse.  
 The Technical Requirements/Specification Details/Quality Requirements/Commercial Terms & Conditions are clearly furnished in the Tender. If Deviation(s) is/are not explicitly brought out in the Offer, it will be construed that the Tenderer is complying with the requirement of BHEL in full without any deviation(s).

For and on behalf of  
**BHARAT HEAVY ELECTRICALS LTD.**

*(Signature)*  
 PURCHASE EXECUTIVE



**BHARAT HEAVY ELECTRICALS LIMITED**  
 (A GOVERNMENT OF INDIA UNDERTAKING)  
 SEAMLESS STEEL TUBE PLANT  
 TIRUCHIRAPALLI - 620 014.  
 TAMILNADU (INDIA)

PHONE : 0431-2578480/8491  
 : 0431-2578406/8419  
 : 0431-2578568  
 FAX : 0431-2576828

TIN : 33243560005  
 CST. No. : 239383  
 Dated : 11.06.1991

**PURCHASE ENQUIRY**

VENDOR CODE <b>23009</b>	ENQUIRY NUMBER <b>9440577E</b>	ENQUIRY DATE <b>06/05/2014</b>	ENQUIRY DUE DATE <b>27/05/2014</b>	No. OF ITEMS <b>01</b>
-----------------------------	-----------------------------------	-----------------------------------	---------------------------------------	---------------------------

Office Copy  
 -----

- IMPORTANT POINTS :**
1. Tender Closing Time : 14.00 Hrs.
  2. Tender Opening Time : 15.00 Hrs.
  3. Tender should be submitted in a sealed cover, duly indicating enquiry No. Enquiry date & Enquiry Due Date on the cover.
  4. Offer(s) received through Courier Services after 14.00 Hrs. on Enquiry Due Date will not be considered.
  5. Late Tender(s) is/are liable for rejection.
  6. Offer(s) shall be valid for 60 days from Enquiry Due Date.
  7. Offer(s) in Vendor's Letter head shall contain.
    - a. Offer No. and Date
    - b. Delivery Period
    - c. Delivery Terms
    - d. Payment Terms
    - e. Excise Duty with Tariff Heading Sales Tax (against form-XVII/Form-C), etc.
    - f. Excise Regn. No. and SSI Regn. No.

Kindly arrange to submit your COMPETITIVE OFFER for the following item(s)  
 If you are not in a position to submit your Offer, kindly arrange to send your REGRET LETTER.

**THIS IS ONLY A REQUEST FOR OFFER AND NOT AN ORDER**

No.	BHEL Material Code and Description	Unit	Requirement	
			Quantity	Delivery
<p><b>SPECIAL NOTE:-</b>            =====  <b>THIS TENDER IS CALLED ON TWO BID SYSTEM.KINDLY REFER THE ANNEXURE-A &amp; C ATTACHED.</b>  <b>CONFIRM THE FOLLOWING COMMERCIAL POINTS WITHOUT FAIL:</b>            -----</p> <ol style="list-style-type: none"> <li>1.OUR STD PAYMENT TERMS IS 100 % PYT WITH IN 45 DAYS ON RECEIPT AND ACCEPTANCE OF MATERIALS THRO E-PAYMENT.FORMAT WILL BE SENT ALONG WITH PUR ORDER.</li> <li>2.PL QUOTE THE RATE ON DOOR DELIVERY BASIS DULY INCLUDING PKG,FORWARDING, FREIGHT AND INSURANCE CHARGES.</li> <li>3.TEST AND GUARANTEE CERTIFICATES ARE TO BE SUBMITTED ALONG WITH SUPPLIES.</li> <li>4.PERFORMANCE BANK GUARANTEE FOR 10 % ON BASIC VALUE IS TO BE SUBMITTED WHILE RELEASING PAYMENT.</li> <li>5.CONFIRM YR ACCEPTANCE FOR LD AND RISK PURCHASE CLAUSES.</li> </ol>				

**IMPORTANT NOTE :**  
 Delivery Terms : "Free Delivery at BHEL-SSTP STORES" is preferable.  
 Payment Terms : 100% payment after 45 days after receipt and acceptance of materials by BHEL.  
 Terms and Conditions of Tender : Please see reverse.  
 The Technical Requirements/Specification Details/Quality Requirements/Commercial Terms & Conditions are clearly furnished in the Tender. If Deviation(s) is/are not explicitly brought out in the Offer, it will be construed that the Tenderer is complying with the requirement of BHEL in full without any deviation(s).

For and on behalf of  
**BHARAT HEAVY ELECTRICALS LTD.**  
  
**PURCHASE EXECUTIVE**

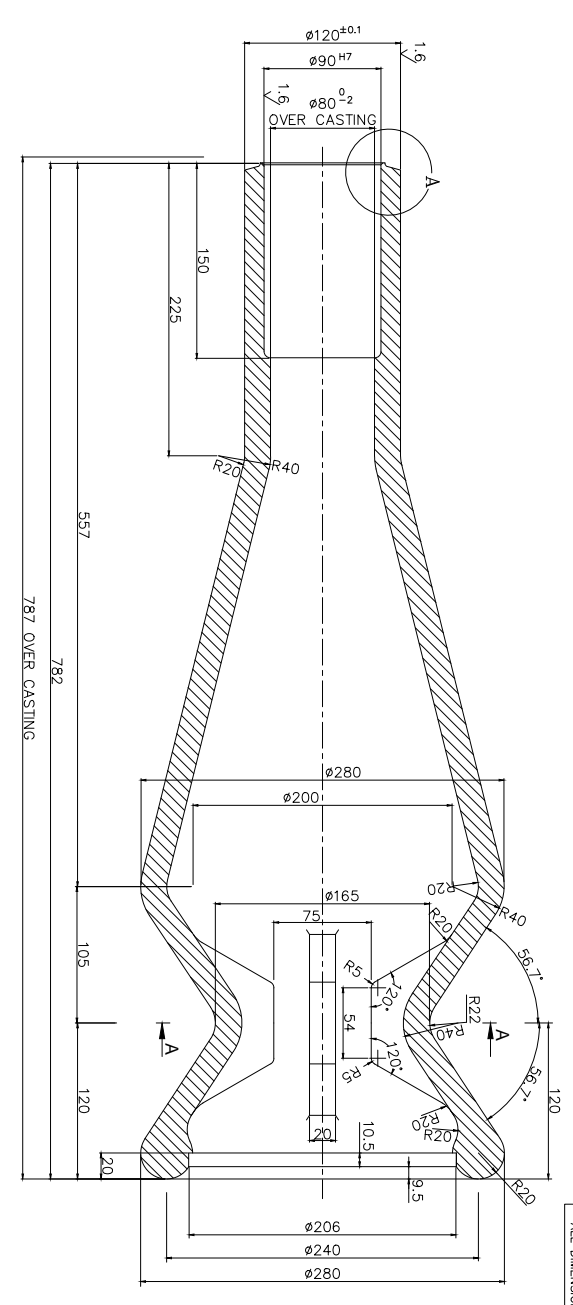
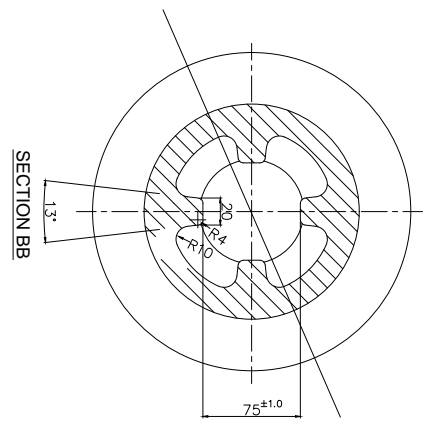
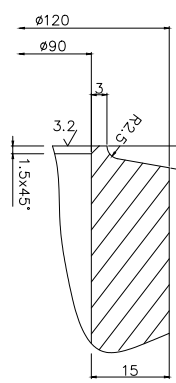
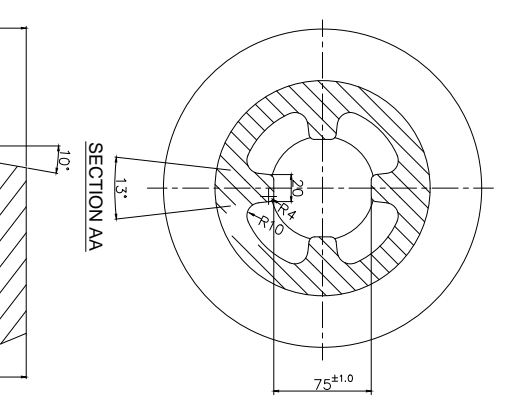

DETAIL OF CHARGE AND DISCHARGE ROLLER  
MATERIAL - HK ALLOY (25% Cr, 20% Ni.)

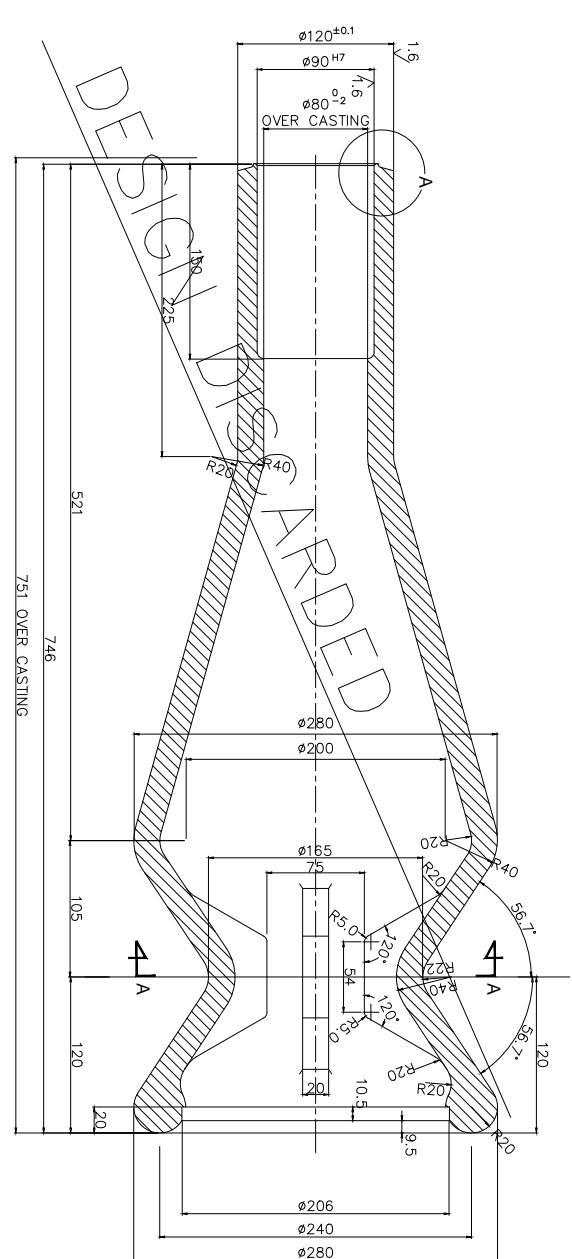

DETAIL OF DISCHARGE ROLLER  
MATERIAL - HK ALLOY (25% Cr, 20% Ni.)

1:6, 3:2:1  
H7 +0.035  
90 0

CAUTION: THE INFORMATION ON THIS DOCUMENT IS THE PROPERTY OF BHARAT HEAVY ELECTRICALS LIMITED. IT MUST NOT BE USED DIRECTLY OR INDIRECTLY IN ANY WAY DETRIMENTAL TO THE INTEREST OF THE COMPANY.

ITEM NO.	DESCRIPTION	DRAWING NO.	MATERIAL	UNIT	QTY
1	WALKING BEAM FURNACE				
DEPT: BHARAT HEAVY ELECTRICALS LTD BRANCH: THRIKUPPALLI - 620014 SCALE: 1:2 WEIGHT (KG): 45 DATE: 24.11.10 DRAWING NO.: 1-7-1150-00-10001 REV: 01					

3/2/16/

Ø100j7	+0.020
Ø65H7	+0.015
Ø65H7	+0.030
Ø65H6	-0.030
Ø65H7	+0.048
Ø65H7	+0.030
Ø65H7	0

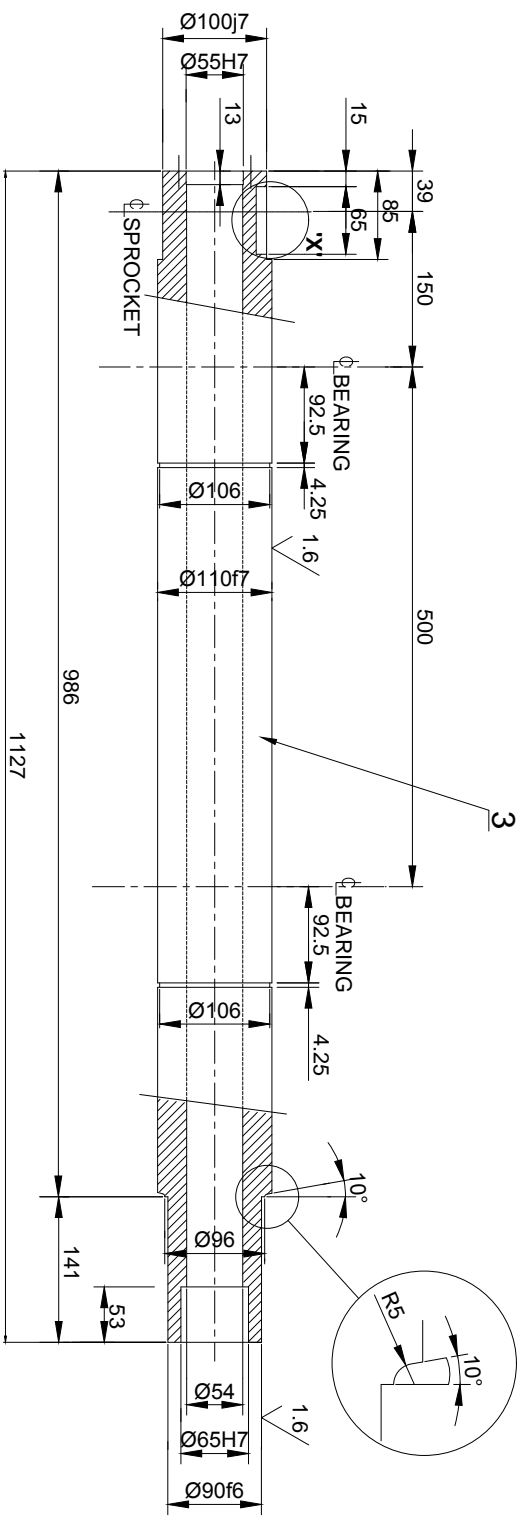
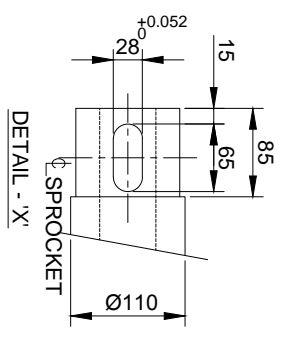
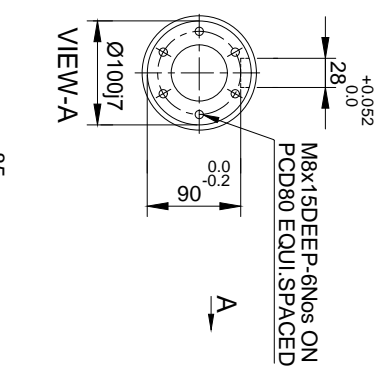
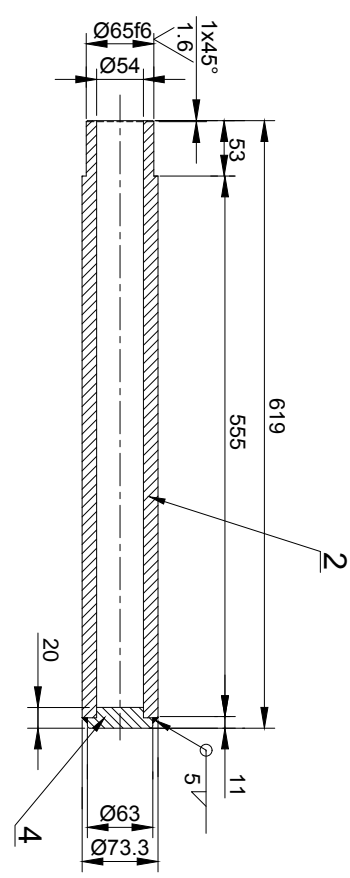
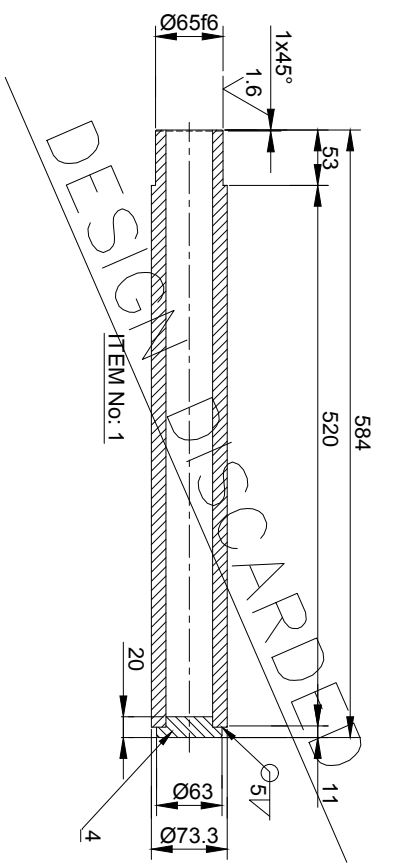

- NOTES:
- ITEM NO. 2 & 3 TO BE ASSEMBLED AND WELDED (from FILLET) STRAIGHTNESS TO BE MAINTAINED WITH THE AXIS.
  - HYDRO TEST SHOULD BE DONE AT 1.5 ATA AFTER ASSY.
  - FOR CHARGE/DISCHARGE ROLLER ASSEMBLY, REFER DRG NO: 7-1150-10-10003

REV	DATE	BY	CHKD	DESCRIPTION
01	21/11/15	SRINIVAS	SRINIVAS	ISSUED FOR MANUFACTURE

CAUTION: THE INFORMATION ON THIS DOCUMENT IS THE PROPERTY OF BHARAT HEAVY ELECTRICALS LIMITED. IT MUST NOT BE USED DIRECTLY OR INDIRECTLY IN ANY WAY DETRIMENTAL TO THE INTEREST OF THE COMPANY.

ITEM NO.	DESCRIPTION	QTY	UNIT	WGT	WGT CODE	UNIT WGT
4	PL 20 X Ø65	2	0.5			
3	SHAFT	1	64			
2	PIPE ASSY	1	13			
1	PIPE ASSY (PIPE)	1	13			

DATE	SCALE	WEIGHT (KG)	WGT TO ASST NO	REV
21/11/15	1:1	110	1-7-1150-10-10002	01

NO.	DATE	BY	CHKD	DESCRIPTION
01	21/11/15	SRINIVAS	SRINIVAS	ISSUED FOR MANUFACTURE



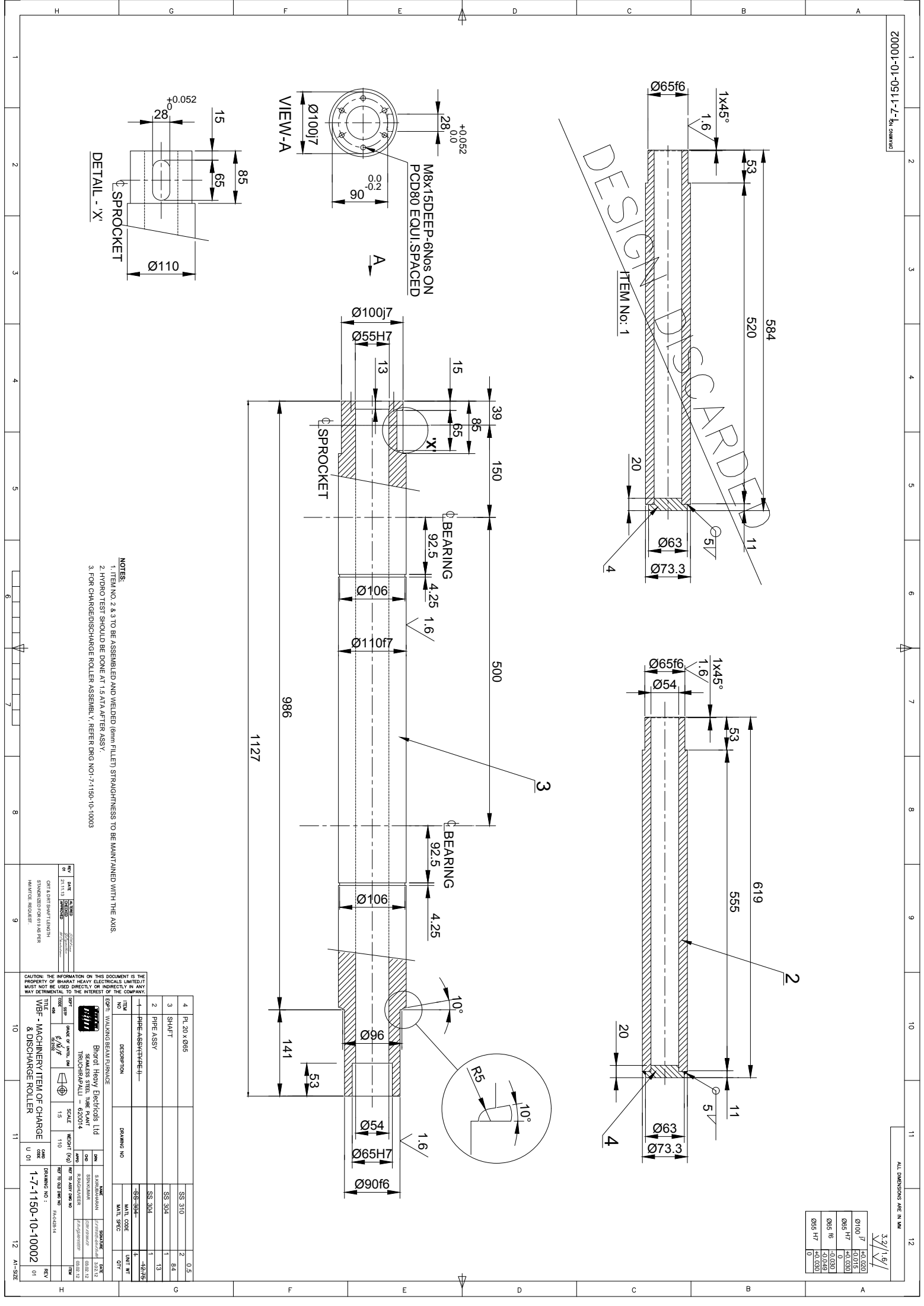

## Annexure-A

### **Important Note to Tenderers - for TWO BID system (including REVERSE AUCTION)**

(Page No. 1 of 4)

1. This Tender is floated on TWO–BID System.
  1. Tenderers are requested to submit their Offers in TWO-BID basis, viz.,
    1. Part I .. Technical and Un-Priced Commercial Bid
    2. Part II .. Price Bid
  2. Both the above Bids are to be submitted before 14.00 hours (Indian Time) on Tender Due Date, as detailed under Point 3.

2. Above Bids are to be submitted in sealed-covers as detailed below :

#### **1. Technical and Un-Priced Commercial Bid :**

1. Shall contain complete Scope of Supply with all Technical details, Specifications, Delivery and other Commercial Terms and Conditions.

2. Shall contain all Commercial Conditions, like Payment Terms, Delivery Terms, Taxes, Duties, Delivery Schedule, Offer Validity.

3. Price columns are to be filled-in only as 'QUOTED' ::

Enq. Sl.No.	BHEL Matl. Code / Description of Material.	Quantity with Unit Name	Unit Rate Rs.	Total Price Rs.
..	..	..	<b>QUOTED</b>	<b>QUOTED</b>

4. Shall contain Point-wise confirmation for all Enquiry Clause Nos., TDC Clause Nos., and other attachments, if any.

5. If any deviation is taken, Technical or Commercial points, the same shall be clearly highlighted in the Offer with Enquiry Clause No(s). and its attachments. Otherwise, it shall be construed by BHEL that the Tenderer is complying with all Enquiry Clauses in full.

6. Any request for modification/change of Technical / Commercial points shall be entertained only before they are frozen..

#### **2. Price Bid :**

1. Shall contain following details **only** ::

Enq. Sl.No.	BHEL Matl. Code / Description of Material.	Quantity with Unit Name	Unit Rate Rs.	Total Price Rs.

2. Wherever required / possible, Break-up-Price details are to be furnished.

3. This Bid shall NOT contain any Technical and/or Commercial Conditions. (If indicated, such terms shall not be taken into consideration).

## Annexure-A

### **Important Note to Tenderers - for TWO BID system (including REVERSE AUCTION)**

(Page No. 2 of 4)

#### 3. **Details for submitting the Offer :**

##### 1. **Cover No.1 – Technical and Un-Priced Commercial Bid :**

1. Put the Technical & Un-Priced Commercial Bid inside Cover No.1 seal it.
2. Mark Cover No.1 as :  
**“Part-I -- TECHNICAL AND UN-PRICED COMMERCIAL BID”**  
**Tender No., Tender Date, Tender Due date, Address of Tenderer..**

##### 2. **Cover No.2 -- Price Bid :**

1. Put the Price Bid inside Cover No.2 and seal it.
2. Mark Cover No.2 as :  
**“Part-II - PRICE BID”**  
**Tender No., Tender Date, Tender Due date, Address of Tenderer..**

##### 3. **Cover No.3 -- Techno-Commercial Bid & Price Bid :**

1. Put Cover No. 1 and 2 inside Cover No.3 and seal it.
2. Mark Cover No. 3, with Tender No., Tender Date, Tender Due date, Address of Tenderer..
3. Address the Cover No.3, to Purchase Executive, BHEL/SSTP, Tiruchirapalli-620014, INDIA.

#### 4. **Tender Opening :**

1. On the Tender Due Date, Technical and Un-Priced Commercial Bid shall alone be opened, in presence of Responded Tenderers / their Authorized Representative, who may like to be present for Tender opening..
2. Clarifications / Confirmations, if any, required by BHEL for Technical / Commercial evaluation , shall be sought from Bidders before opening the Price Bid.
3. Price Bid of Technically suitable Bidders alone would be opened, on a pre-determined date, in presence of the Responded Tenderers / their Authorized Representative, who may like to be present for such opening.

#### 5. **General :**

1. Incomplete Offers shall be liable for rejection.
2. Fixed Price :  
Bidder shall quote only Fixed Rate / Price and not subject to any escalation whatsoever during the period of Bid Validity and execution of Purchase Order. Any Bid with adjustable or price variation clause shall be treated as ‘Non-Responsive’ and liable for rejection. Prices shall be written both in numbers and words. In the event of any difference, the price in words shall be valid and binding. Unit Rate shall only be considered as correct and valid, which shall be taken for further consideration.

## Annexure-A

### **Important Note to Tenderers - for TWO BID system (including REVERSE AUCTION)**

(Page No. 3 of 4)

3. Taxes and Duties :  
All Taxes / Duties payable extra to the quoted rate, shall be specifically indicated in the Un-Priced Bid, failing which the quoted rates shall be considered as 'all inclusive'.  
  
Offer shall carry clear details of Tariff Heading No. and applicable Rate of ED / ST (along with Rate of Cess, if any).
4. Validity :  
Offer shall be kept valid for acceptance for a period of 60 days (sixty days) from the date of opening of the Technical & Un-Priced Bid.
5. Terms of Payment :  
100% payment shall be paid within 60 to 90 days, after receipt and acceptance of materials at BHEL/SSTP.
6. Liquidated Damages, Risk Purchase and Warranty :  
BHEL standard Clauses are applicable  
(Ref : Clause Nos. 6,7 & 9 of Terms and Conditions of Enquiry available on the reverse of pre-printed Enquiry sheet).
7. Evaluation of the Offers shall be on the basis of 'To-Door Cost at SSTP' (NET Cash outflow to BHEL)
8. BHEL reserves the right to ordering on Public Sector Enterprises under Price-Preference facilities as admissible in the existing policy.
9. BHEL reserves the right to reject any Tender due to unsatisfactory past performance in the execution of a Contract.
10. **BHEL reserves the right to resort for a REVERSE AUCTION (RA), i.e. ON-LINE BIDDING THROUGH INTERNET,** instead of opening the sealed Price Bid submitted earlier, which shall be decided after Technical evaluation.
11. **In case BHEL decides NOT to resort for RA, Price Bids and Price-Impacts, if any, already submitted by Bidder and available with BHEL, shall be opened, as detailed under Point 4 above.**
12. **Information and General Terms and Conditions governing RA, are detailed below:**
  1. Technically and Commercially acceptable Bidders shall only be eligible to participate in the RA.
  2. BHEL shall engage the services of a Service Provider, who shall extend all necessary training and assistance before commencement of ON-LINE-BIDDING through Internet, at NO extra-cost to the Bidders.
  3. Eligible Bidders shall be informed in writing, about the details of Service Provider, to enable Vendors to contact the Service Provider and get trained.

## Annexure-A

### **Important Note to Tenderers - for TWO BID system (including REVERSE AUCTION)**

(Page No. 4 of 4)

4. RA Business Rules, like Event Date, Time, Start Price, Bid Decrement, Time-Extensions, etc. shall also be communicated through the Service Provider for compliance by Bidders.
5. Vendors have to FAX the Compliance Form in the prescribed format (to be furnished by the Service Provider), before start of RA. Without furnishing the above Compliance Form, Bidders shall not be eligible to participate in the RA.
6. BHEL shall provide the calculation sheet (eg., EXCELL sheet) through the Service Provider, which shall be helpful to arrive at “TOTAL COST to BHEL”, like Packing and Forwarding Charges, Taxes and Duties, Freight Charges, Insurance, Service Tax and other loading factors (for non-compliance to BHEL Standard Commercial Terms and Conditions), for each of the Bidder, to enable them to fill in the price and keep it ready for inputting data during the RA.
7. RA shall be conducted on a pre-determined Date and Time.
8. At the end of RA, the lowest Bid Value will be known on the Network.
9. Lowest Bidder has to FAX the Prescribed Format, duly filled in and signed in, as provided, on a case-to-case basis, to the Service Provider, within 24 Hours of RA without fail.
10. Any variation between the ON-LINE Bid Value and the signed document will be considered as unethical the Tender process and will invite disqualification of Bidder, for further business dealings with BHEL as per the prevailing procedure.

.....oo0oo.....

**Annexure – C.**  
**Commercial Conditions**

Vendor Code:	Vendor Name:	
Tender No.:	Tender Date:	Tender Due Date:

Sl.No	Commercial Terms	Accepted
C1.	<u>Delivery Terms :</u> Free delivery at BHEL/SSTP Stores duly including Packing, Forwarding, Freight and Insurance charges	
C2.	<u>Payment :</u> 100% after 45 days after receipt and acceptance of materials by BHEL	
C3.	<u>LIQUIDATED DAMAGES:</u> It is clearly understood among the parties to the Contract that <b>TIME IS THE ESSENCE OF THE CONTRACT</b> . Therefore, the delivery of the goods specified in the Purchase Order shall be made within the time prescribed. Where the Seller supplies or despatches the goods, beyond the delivery period specified, and the Purchaser will have no obligation to accept the goods. If accepted, Liquidated Damages at the rate of 0.5% (Zero point five Percent) of the value of goods delayed, per week of delay, subject to a maximum of 10% (Ten Percent) or part thereof, will be levied without prejudice to any other relief or compensation due to the Purchaser under any other conditions of the Contract.  <u>RISK PURCHASE:</u> Alternatively, the Purchaser, at his option, will be entitled to terminate the Contract and to purchase elsewhere at the risk and cost of Seller, either the whole of the goods or any part, which the Seller has failed to deliver or dispatch within the time stipulated as aforesaid or if the same were not available the best and nearest available substitute thereof. The Seller shall be liable for any loss, which the Purchaser may sustain by reason of such Risk Purchase(s), in addition to penalty at the rate mentioned in Clause No.06 above.	
C4.	<u>Delivery Period :</u> As per Enquiry schedule.	
C5.	<u>Validity – minimum 60 Days from the date of Tender Opening.</u>	
<u>Deviations if any (attach additional sheet, if required) :</u>		

Sl.No.	Commercial Terms	
C6.	Validity of Offer (Date)	
C7.	Excise Duty (including Cess) % (with Break up details)	
C8.	TVNAT / CST (%)	
C9.	Delivery Period (Days/Weeks/Months) Please refer the Enquiry.	
C10.	Other Cost (if any) - % (or) Rs.	
C11.	Are you Micro/Small/Medium Industry? (If YES, please furnish MSM Regn.No., along with a copy of MSM Certificate)	YES / NO MSM No. MSM Certificate enclosed(Yes/NO)

Signature with Date :

**Respective procurement Groups shall incorporate the applicable conditions in the NIT for Indigenous and Imports separately.**

<b>Payment Term (Indigenous)</b>	
<b>If materials are receivable at Stores/Trichy <u>without PBG</u></b>	Payment term is 100% direct payment after 45 days from the date of receipt and acceptance of materials.
<b>If materials are receivable at Stores/Trichy <u>with PBG</u></b>	Payment term is 100% direct payment after 45 days from the date of receipt and acceptance of materials and against 10% PBG valid for the warranty period.
<b>Any deviation in the above payment term will attract loading as mentioned below. “Base rate of SBI (as applicable on the date of bid opening. Techno-commercial bid opening in case of two part bids) + 6% shall be considered for loading for the period of relaxation sought by bidders.</b>	

<b>Payment Term (Indigenous)</b>	
<b>If materials are receivable at Project Sites without PBG</b>	<b>Option-1:</b> Payment term is 100% direct payment after 45 days from the date of dispatch against site acknowledgement <b>Option-2:</b> Payment term is 90% direct payment after 45 days from the date of dispatch against submission of dispatch documents and balance 10% against site acknowledgement. <b>For this option -2, a loading of 2% on the 90% of the offered value shall be made.</b>
<b>If materials are receivable at Project Sites with PBG</b>	<b>Option-1:</b> Payment term is 100% direct payment after 45 days from the date of dispatch against site acknowledgement and against 10% PBG valid for the warranty period. <b>Option-2:</b> Payment term is 90% direct payment after 45 days from the date of dispatch against submission of dispatch documents and 10% PBG valid for the warranty period and balance 10% against site acknowledgement. <b>For this option -2, a loading of 2% on the 90% of the offered value shall be made.</b>

<b>To be incorporated in all NITs addressed to Indigenous Suppliers</b>	Payment through Bank is not preferred. In case of Payment through Bank is opted by Supplier, BHEL prefers documents submission through bank with copy of LR and door delivery of Goods to Site/Stores with Consignee copy attached. In this case Loading will be 3% on the offered value. In case of Direct to Site (DTS), only 90% through bank will be considered.
	Offers of indigenous Suppliers with payment terms as LC/Advance Payment are liable for rejection.

**Payment Term (Imports) - To be incorporated in all NITs addressed to Import Suppliers**

BHEL Payment term is 100% payment on CAD basis after 45 days from the date of receipt of documents, specified in PO, at BHEL bank. Respective bank charges to respective account.

**Any deviation in the above payment term will attract loading as mentioned below. “Base rate of SBI (as applicable on the date of bid opening. Techno-commercial bid opening in case of two part bids) + 6% shall be considered for loading for the period of relaxation sought by bidders.**

**In the case of Usance LCs the loading will be considered @ 1.5% on the offered Value.**

**For LC at sight the loading will be considered @ 3.5% on the offered Value.**

**Normally CAD at sight and Confirmed LCs are liable for rejection.**

**Liquidated Damages / Penalty - To be incorporated in all NITs addressed to both Indigenous and Import Suppliers**

Liquidated damages shall be 0.5% of the total order value per week or part thereof subject to a maximum of 10% of the total order value.

For staggered delivery schedule, LD shall be 0.5% of the undelivered portion per week of the delay or part thereof subject to a maximum of 10% of the total order value.

Any deviation from the above LD clause, loading will be applied to the extent to which it is not agreed by the bidder (at offered value).

**Guarantee / Warranty Period - To be incorporated in all NITs addressed to both Indigenous and Import Suppliers**

Normally No deviation permitted and the deviated offers are liable for rejection.

**Performance Bank Guarantee - To be incorporated in all NITs addressed to both Indigenous and Import Suppliers**

Normally No deviation permitted and the deviated offers are liable for rejection.

**To be incorporated in all NITs addressed to both Indigenous and Import Suppliers**

BHEL will consider the ranking after the loading is applied as referred above wherever deviations are observed.

## Certificate by Chartered Accountant

This is to Certify that M/S .....  
(hereinafter referred to as 'company') having its registered office at  
..... is registered under MSMED Act 2006, (Entrepreneur  
MeMemorandum No (Part—II)..... dtd:.....,  
Category:..... (Micro/Small)). (Copy enclosed).

Further verified from the Books of Accounts that the investment of the company as on  
date ..... as per MSMED Act 2006 is as follows:

1. **For Manufacturing Enterprises: Investment in plant and machinery** (i.e. original cost excluding land and building and the items specified by the Ministry of Small Scale Industries vide its notification No.5.0.1722(E) dated October 5, 2006:  
**Rs. ....Lacs**
2. **For Service Enterprises: Investment in equipment** (original cost excluding land and building and furniture, fittings and other items not directly related to the service rendered or as may be notified under the MSMED Act, 2006:  
**Rs. ....Lacs**

The above investment of Rs..... Lacs is within permissible limit of  
Rs .....Lacs for ..... Micro / Small (~~Strike off which is not applicable~~)  
Category under MSMED Act 2006.

Date:

(Signature)

Name -

Membership number -

Seal of Chartered Accountant