



Bharat Heavy Electricals Limited
(Seamless steel Tube Plant)
Tiruchirappalli – 620014, TAMIL NADU, INDIA

TITLE: SUPPLY OF KR – 75 Rolls	Phone: +91 431 257 8480 Email : neerajxalxo@bheltry.co.in Web : www.bhel.com
---------------------------------------	--

Reference Number: 9231402E	Date: 20.03.2014	Due date for submission of application: 10.04.2014
-----------------------------------	-------------------------	---

BHEL/SSTP, Trichy is looking for vendors to supply KR-75 Rolls as per Tender documents attached.

A. Important Note to New Vendors

The new vendors will be required to furnish the following documentary proof/ information along with their offers:

1. Certificate of registration (copy of certificate to be submitted).
2. Banker's information (copy of bank pass book first page to be submitted).
3. MSME vendor certificate (if applicable).
4. Address of your organization (complete postal address with PINCODE).
5. Contact person's Phone No. / Mobile No. / FAX No. / E-mail ID.
6. Statutory documents – VAT / TIN / EXCISE REGISTRATION / CST REGN / SERVICE TAX REGISTRATION etc. (copy to be furnished)
7. NSIC/SSI Certificate (if applicable)
8. ISO Certificate (if applicable)
9. Experience certificate as proof of supply of similar items to any Govt. agencies / PSU / Organisations (copy of PO's to be furnished).
10. Audit Report/ IT Return (if applicable)
11. Agency agreement with manufacturer (if applicable)
12. Partnership Deed (if applicable).

If the new vendors fail to submit the above documentary proof/information, their offers will not be considered for this enquiry.



An ISO 9001
Company

Bharat Heavy Electricals Limited (Seamless steel Tube Plant)

Tiruchirappalli – 620014, TAMIL NADU, INDIA



B. Important Note to MSE Vendors

1. 20% of the tendered quantity is earmarked for MSE suppliers in this tender.
2. Out of the 20% tendered quantity reserved for MSE suppliers, 4% shall be earmarked for procurement from MSE owned by SC / ST entrepreneurs.
3. In case MSE vendor participating in the tender quotes within the price band of L1 + 15%, they will be allowed to supply the portion of the requirement subject to acceptance of L1 price by MSE vendor. In case of more than one such MSE, the supply shall be shared proportionately.
4. MSE suppliers can avail the intended benefits only if they submit along with offer, attested copies of either EM II certificate having deemed validity (Two years from the date of issue of acknowledgement in EM II) or valid NSIC certificate or EM II certificate along with CA certificate (Format enclosed) applicable for the year, certifying quantum of investment in plant and machinery within the permissible limit as per the act for relevant status (Micro or small) where the deemed validity of EM IIIs over. Date to be reckoned for determining the deemed validity will be the last date of technical bid submission. Non submission of such documents will lead to consideration of their bids at par with other bidders and MSE status of such suppliers shall be shifted to Non MSE supplier till the supplier submits these documents.

Purchase Officer / Purchase /SSTP

Phone: 0431-257 8440.

Mail: neerajxalxo@bheltry.co.in

 S40-003/D	BHARAT HEAVY ELECTRICALS LTD. (A GOVERNMENT OF INDIA UNDERTAKING) SEAMLESS STEEL TUBE PLANT TIRUCHIRAPPALLI - 620 014. TAMIL NADU.	PHONE : 0431-2578480, 2578547,2578428, 2578406	TIN : 33243560005		
		FAX : 0431-2520464/383	CST No. 239383 Dated 11.06.1991		PURCHASE ENQUIRY
VENDOR CODE 25376	ENQUIRY NUMBER 9231402E	ENQUIRY DATE 20/03/2014	ENQUIRY DUE DATE 10/04/2014	No. OF ITEMS 01	
Office Copy -----		IMPORTANT POINTS : 1. Tender Closing Time - 14.00 Hrs. 2. Tender Opening Time - 15.00 Hrs. 3. Tender should be submitted in a sealed cover, duly indicating enquiry No., Enquiry date & Enquiry Due Date on the cover. 4. Offer(s) received through Courier Services after 14.00 Hrs. on Enquiry Due Date not be considered. 5. Late Tender (s) is/are liable for rejection. 6. Offer(s) shall be valid for 60 days from Enquiry Due Date. 7. Offer(s) in Vendor's Letter-Head shall contain: a. Offer No. and Date b. Delivery Period c. Delivery Terms d. Payment Terms e. Excise Duty with Tariff Heading Sales Tax (against form-XVIII-Form-C), etc. f. Excise Regn. No. and SSI Regn. No.			
Kindly arrange to submit your COMPETITIVE OFFER for the following item(s). If you are not in a position to submit your Offer, kindly arrange to send your REGRET LETTER .					
THIS IS ONLY A REQUEST FOR OFFER AND NOT AN ORDER					
Sl.No.	BHEL Material Code and Description	Unit	Requirement		
			Quantity	Delivery	
01	BHEL Material Code : SP6925110014 ----- KR 75 ROLL DRAWING No. : 20.ST.232.01.008/03 TDC No. : TDC/TE/MFG - 14 REV.No. : 01 DATE : 17.07.2009	Nos.	01	36.000	30/09/2014
Foot Note :: ----- 1. This Tender is floated on TWO-BID basis. 2. Following details are enclosed. a. Annexure-A - Important Note to Tenderers. Tenderers are requested to submit their Offers in TWO-BID basis, viz., I. Part I .. Technical and Un-Priced Commercial Bid II. Part II .. Price Bid b. Annexure-B - Technical Conditions c. Annexure-C - Commercial Conditions 3. Tenderers are required to fill in above Annexure-B and C and enclose them along with their UN-PRICED BID. 4.a. Delivery date furnished in the Enquiry is only indicative. 4.b. For Delivery Schedule - Pl. refer Clause No. C.4 of Annexure- C. 5. Price Bid of Vendors, who accept the Clause No. B.1 & B.2 of Annexure-B & C.1 to C.5 of Annexure- C. shall only be considered for further processing. Fill the Annexure-B & C and enclose it with Technical and Un-Priced Commercial Bid. 6. Annexure-D Note to MSE Vendors enclosed. Send your MSE Certificate accordingly. 7. We highlight Clause Nos. 6 and 7 (LD and Risk Purchase) of Enquiry Terms and Conditions, printed overleaf.					
Indent Details -----					
IMPORTANT NOTE : Delivery Terms : "Free Delivery at BHEL-SSTP STORES" is preferable. Payment Terms : 100% payment within 45days after receipt and acceptance of materials by BHEL. Terms and Conditions of Tender : Please see reverse. The Technical Requirements / Specification Details / Quality Requirements/Commercial Terms & Conditions are clearly furnished in the Tender. If Deviation(s) is/are not explicitly brought out in the Offer, it will be construed that the Tenderer is complying with the requirement of BHEL in full without any deviation(s).			For and on behalf of BHARAT HEAVY ELECTRICALS LTD.  PURCHASE EXECUTIVE		

IMPORTANT NOTE TO TENDERERS
(FOR INDIGENOUS & OVERSEAS SUPPLIERS)

This Tender is floated on TWO-BID System. Tenders are requested to submit their offers in TWO-BIDS (Part I: Un priced bid and Part II: Price Bid) separately in a sealed cover as follows.

1. **Part I: UN PRICED BID:** (Complete with technical & Commercial conditions as per enquiry including un priced copy of price schedule i.e. identical to part II with prices blanked and replaced by “Quoted”) .

The Tenderer should confirm their acceptance / comments to the Enquiry along with other commercial Terms & Conditions of the Tender. In case any deviation is taken by the Tenderer from the Tender requirements, it is to be clearly indicated in the offer with reference to the particular clause. If such deviations are not explicitly indicated in the offer, it will be construed by BHEL that the Tenderer is complying with Annexure Clause(s), Commercial terms & conditions and other conditions in full.

2. **Part II: PRICE BID:** Price (with break-up details wherever required) to be indicated.
3. **Both Un priced Bid and Price Bid is** to be submitted in a single envelop before 1400 hours (Indian Time) on tender Due Date.
4. The **Unpriced Bid** shall be put in a separate sealed cover superscribed with Tender number, Tender Date & Tender Due Date and also the cover should be clearly marked with “UNPRICED BID”.
5. The **Price Bid** shall be put in a separate sealed cover superscribed with Tender number, Tender Date & Tender Due Date & the cover should be clearly marked with “PRICE BID”.
6. Both the individually enveloped **UNPRICED BID** and **PRICE BID** covers as mentioned above, have to be put in another single bigger cover clearly indicating Tender number, Tender Date & Tender Due Date at the top of the cover.
This cover is to be addressed to

Purchase Executive,
Purchase Department,
Seamless Steel Tube Plant (SSTP),
BHEL, Tiruchirapalli-620014, India.
Phone No: 91 431 2578502, 2578491

7. Unpriced Bid shall only be opened on the Tender Due Date mentioned in the Tender, in the presence of Tenderers / their Authorized Representative, who may like to be present for such opening. The price bid will NOT be opened on the date of tender opening.
8. After opening the Unpriced Bid, they shall be evaluated by BHEL for their suitability. BHEL shall hold discussions with the responded Tenderers on the Technical and Commercial terms and freeze the terms & conditions of the offer.. These frozen technical specifications will be communicated to responded tenderers.
9. BHEL shall offer opportunity to the responded and technically / commercially suitable Tenderers, to submit their latest Price Bid/ Impact of prices, if any in line with the frozen technical, Commercial, delivery conditions.
10. This latest Price Bid & the Impact of prices for the frozen technical specifications submitted by the Tenderers will be opened in the presence of Tenderers. Based on the above, the ranking of the Tenderers shall be made and accordingly the Tender shall be finalized.

Annexure – B.
Technical Conditions
(Page No. 1 of 2)

Vendor Code:	Vendor Name:	
Tender No.:	Tender Date:	Tender Due Date:

:

Sl.No.	Technical Requirement	Accepted
B.1.	To supply of Materials as per Tender Specifications / Drawings without any deviation.	
B.2.	The Roll profile checking template shall be collected by the supplier from SSTP / BHEL to check the Roll profile.	
B.3.	The template shall be returned along with the final supply by the supplier without fail. Otherwise the cost of the template will be recovered from the suppliers Bill.	
B.4.	To supply of materials with suitable preservation and packing	

Deviations, if any (attach additional sheet, if reqd) :

Signature with Date	Seal

Annexure – C.
Commercial Conditions
(Page No. 2 of 2)

Vendor Code:	Vendor Name:	
Tender No.:	Tender Date:	Tender Due Date:

Sl.No.	Commercial Terms	Accepted						
C1.	<u>Delivery Terms</u> : Free delivery at BHEL/SSTP Stores.							
C2.	<u>Payment</u> : 100% after 45 days after receipt and acceptance of materials by BHEL							
C3.	<u>LIQUIDATED DAMAGES</u> : It is clearly understood among the parties to the Contract that TIME IS THE ESSENCE OF THE CONTRACT. Therefore, the delivery of the goods specified in the Purchase Order shall be made within the time prescribed. Where the Seller supplies or despatches the goods, beyond the delivery period specified, and the Purchaser will have no obligation to accept the goods. If accepted, Liquidated Damages at the rate of 0.5% (Zero point five Percent) of the value of goods delayed, per week of delay, subject to a maximum of 10% (Ten Percent) or part thereof, will be levied without prejudice to any other relief or compensation due to the Purchaser under any other conditions of the Contract. <u>RISK PURCHASE</u> : Alternatively, the Purchaser, at his option, will be entitled to terminate the Contract and to purchase elsewhere at the risk and cost of Seller, either the whole of the goods or any part, which the Seller has failed to deliver or dispatch within the time stipulated as aforesaid or if the same were not available the best and nearest available substitute thereof. The Seller shall be liable for any loss, which the Purchaser may sustain by reason of such Risk Purchase(s), in addition to penalty at the rate mentioned in Clause No.06 above.							
C4.	<u>Delivery period required</u> : <table border="1" style="margin-left: auto; margin-right: auto;"> <tr> <td>Delivery from PO Date</td> <td>Enq.Sl. Nos. 1</td> </tr> <tr> <td>Within 4 Months</td> <td>12 Nos</td> </tr> <tr> <td>Within 6 Months</td> <td>24 Nos</td> </tr> </table>	Delivery from PO Date	Enq.Sl. Nos. 1	Within 4 Months	12 Nos	Within 6 Months	24 Nos	
Delivery from PO Date	Enq.Sl. Nos. 1							
Within 4 Months	12 Nos							
Within 6 Months	24 Nos							
C5.	Validity of Offer - 60 Days from the Date of Tender Opening.							

Sl.No.	Commercial Terms	
C6.	a. Excise Duty Tariff Heading	
	b. Excise Duty (%)	
	c. CESS on ED (%)	
	d. Total of ED and CESS (%)	
C7	a. TVNAT (%)	
	b. CST (%)	
C8.	Other Cost (if any) - % (or) Rs.	
C9	Are you Micro/Small/Medium Industry? (If YES, please furnish MSM Regn.No., along with a copy of MSM Certificate)	YES / NO MSM No. MSM Certificate enclosed(Yes/NO)

Signature with Date & Seal ::

Annexure-D

Important Note to MSE Vendors

1. 20% of the tendered quantity is earmarked for MSE suppliers in this tender.
2. Out of the 20% tendered quantity reserved for MSE suppliers, 4% shall be earmarked for procurement from MSE owned by SC / ST entrepreneurs.
3. In case MSE vendor participating in the tender quotes within the price band of L1 + 15%, they will be allowed to supply the portion of the requirement subject to acceptance of L1 price by MSE vendor. In case of more than one such MSE, the supply shall be shared proportionately.
4. MSE suppliers can avail the intended benefits only if they submit along with offer, attested copies of either EM II certificate having deemed validity (Two years from the date of issue of acknowledgement in EM II) or valid NSIC certificate or EM II certificate along with CA certificate (Format enclosed) applicable for the year, certifying quantum of investment in plant and machinery within the permissible limit as per the act for relevant status (Micro or small) where the deemed validity of EM II is over. Date to be reckoned for determining the deemed validity will be the last date of technical bid submission. Non submission of such documents will lead to consideration of their bids at par with other bidders and MSE status of such suppliers shall be shifted to Non MSE supplier till the supplier submits these documents.

Certificate by Chartered Accountant

This is to Certify that M/S,
(hereinafter referred to as 'company') having its registered office at
..... is registered under MSMED Act 2006, (Entrepreneur
MeMemorandum No (Part—II).....dtd:.....,
Category:..... (Micro/Small)). (Copy enclosed).

Further verified from the Books of Accounts that the investment of the company as on
date as per MSMED Act 2006 is as follows:

1. For Manufacturing Enterprises: Investment in plant and machinery (i.e. original cost excluding land and building and the items specified by the Ministry of Small Scale Industries vide its notification No.5.0.1722(E) dated October 5, 2006:

Rs. Lacs

2. For Service Enterprises: Investment in equipment (original cost excluding land and building and furniture, fittings and other items not directly related to the service rendered or as may be notified under the MSMED Act, 2006:

Rs. Lacs

The above investment of Rs Lacs is within permissible limit of
Rs Lacs for Micro / Small (Strike off which is not
applicable)

Category under MSMED Act 2006.

Date:

(Signature)

Name -

Membership number -

Seal of Chartered Accountant

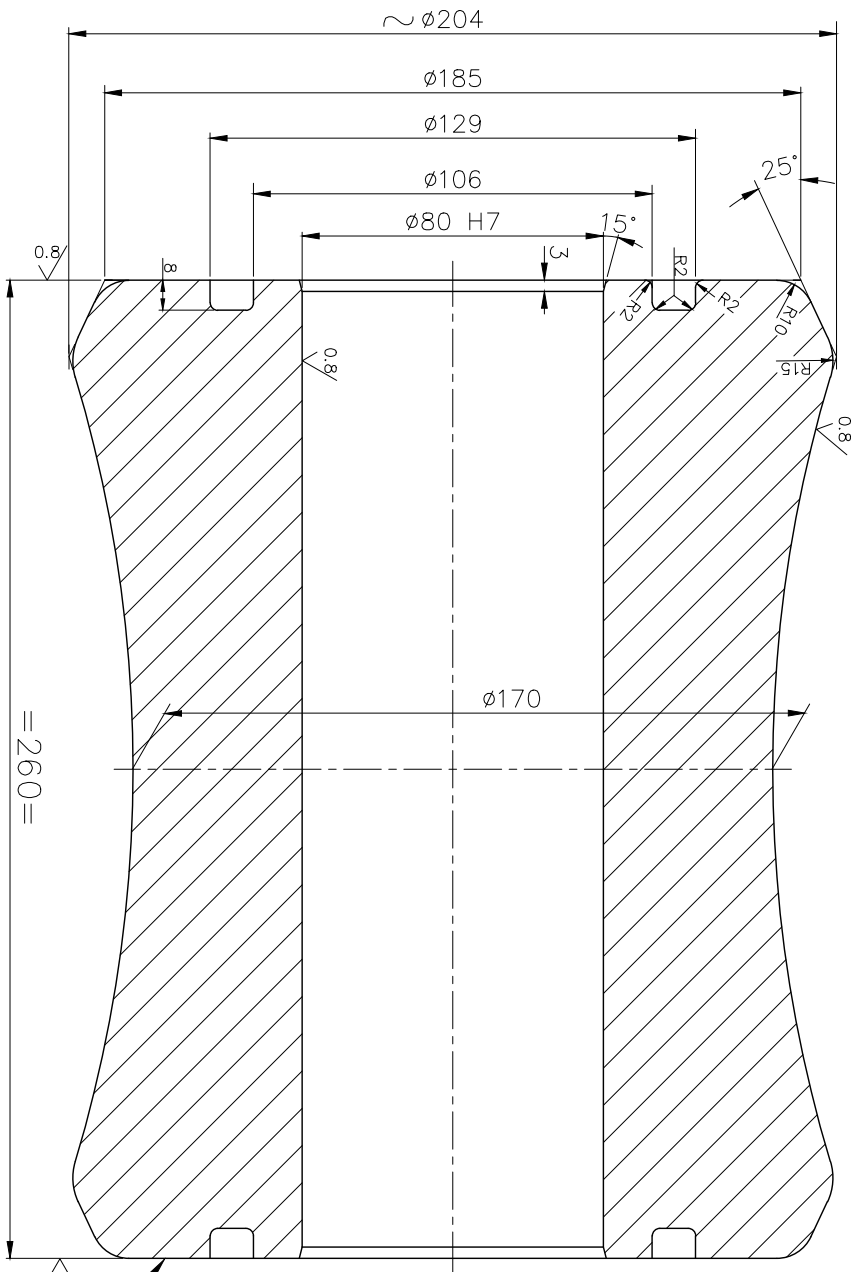

PROFILE AREA	POSITION OF ϕ	1.6/0.8/
	PROFILE	
	ADMISSIBLE DIFFERENCE BETWEEN "A" AND "B"	80 H7 0
	ADMISSIBLE RADIAL RUNOUT 0.05mm	+0.030 0

* MARK : MATERIAL CODE No., FIRM'S NAME, P.O. No. & S.L. No.
SUPPLY TO BE AS PER TDC/TE/MFG-14
OIL HARDEN TO 58 ±2HRC

MATERIAL: X165CrMoV12(DIN 1.2601)
CHEMICAL COMPOSITION

C	Si	Mn	P	S	Cr	Mo	V	W
1.55	0.25	0.20	max: 0.035	max: 0.035	11.00	0.50	0.10	0.40
1.75	0.40	0.40			12.00	0.70	0.50	0.60

MATERIAL CODE No. 69 25 11 001 4

		Bharat Heavy Electricals Ltd SEAMLESS STEEL TUBE PLANT THIRUCHIRAPPALLI - 620014		DATE: 25.03.09 DRAWN BY: IN ARJUNGANANAR CHECKED BY: M. MARUDHAYANAN	
DEPT	T E	SCALE	WEIGHT (Kg)	DATE	DATE
03	25.03.09	1:1	44.0	06.03.14	07.03.14
TDC NOTE ADDED			DRAWING NO.: 20-ST-232-01-008		
REV: 03			REV: 03		

BHEL, Tiruchirapalli-620014		SSTP / Tool Engineering		Technical Delivery Conditions	
Product : KR75 & KR150ROLL					
Document No.		Revision No.		Effective Date	
TDC/TE/MFG- 14		01		17.07.09	
Revision Record		01 - TDC reviewed and revised			

1.0 PRODUCT:

Sl.No.	Equipment / Product	Drg. No.	Drg. Rev. No.
1.	KR 75 Roll	20.ST.232.01.008	AS PER LATEST ENQUIRY / PURCHASE ORDER
2.	KR150 Roll	20.ST.231.01.149	

2.0 APPLICATION:

For straightening the finished tubes in cold condition.

3.0 MATERIAL:

1. **DIN 1.2601 – X165CrMoV12 (Rolled Steel)**

2. Conduct Ultrasonic Test on Raw Material after proof machining in accordance with SA 388.

3. Acceptance Standard in accordance with AM 203.2(c), ASME Sec VIII Div.2. Shall be certified by NDT Level II qualified personnel as per SNT-TC-1A (Society for Non destructive Testing)

4. **Chemistry** : As per drawing

Original mill test certificate shall be provided. Otherwise copy of original mill test certificate and test report from NABL accredited lab for chemical check on sample from the procured material shall be provided.

4.0 DIMENSIONS AND TOLERANCE:

As given in the drawing

5.0 HEAT TREATMENT:

Sl.No.	Process	Detail
1.	Stress Relieving	600 - 650 Deg.C ; Soaking 1 Hr. Furnace Cooling
2.	Hardening	980 - 1020 Deg.C Oil quenching
3.	Tempering	300 - 400°C

6.0 DIMENSIONAL INSPECTION:

Dimensional inspection shall be carried out by the supplier - Acceptance as per drawing.

7.0 NON DESTRUCTIVE TESTING :

1.LIQUID PENETRANT INSPECTION:

To be conducted on entire surface after finish machining as per **ASTM E165-02** and shall be certified by NDT Level II qualified personnel as per SNT-TC-1A

BHEL, Tiruchirapalli-620014	SSTP / Tool Engineering	Technical Delivery Conditions	
Product KR75 & KR150 ROLL			
Document No.	Revision No.	Effective Date	Page No.
TDC/TE/MFG- 14	01	17.07.09	2 of 2

8.0 MECHANICAL TESTING :

1. Hardness Test on job as per DIN EN ISO 6508-1. - Acceptance as per Drawing.

9.0 MARKING:

As given in the drawing.



10.0 TEST CERTIFICATE/REPORT:

Following test certificates shall be sent with materials. In all the TCs & reports BHEL PO No., component name, TDC NO. and drawing no. shall be mentioned where ever applicable: Traceability data like Heat / Melt No. & job Sl. No. shall be provided in all the reports.

1. Raw Material Chemistry (Clause 3.0)
2. Hardness Test (Clause 8.0)
3. Temperature-Time-Recorder Chart for the Heat Treatment Cycle followed
4. Ultrasonic Test Report for Raw Material (Clause 3.0)
5. Liquid Penetrant Test (Clause 7.0)
6. Dimension Report (Clause 6.0)

11.0 PRESERVATION & PACKING :

1. Supply with rust preventive coating which shall be dry after application and removable by common solvents.
2. Pack suitably to avoid transit & handling damages

Prepared By	Reviewed By	Approved By
 DM / TE	 DGM / QA&C	 AGM / TE