

**1X700 MW BELLARY THERMAL POWER STATION UNIT NO. 3, STAGE-3**

**VOLUME: II B & III**

TECHNICAL SPECIFICATION  
FOR  
**OZONE GENERATION PLANT**  
REV 00

**SPECIFICATION NO.: PE-TS-367-174-14000A-A001**



**BHARAT HEAVY ELECTRICALS LIMITED**  
**POWER SECTOR**  
**PROJECT ENGINEERING MANAGEMENT**  
**NOIDA, INDIA**



TITLE: <b>TECHNICAL SPECIFICATION FOR OZONE GENERATION PLANT 1X700 MW BELLARY THERMAL POWER STATION UNIT NO. 3, STAGE-3</b>	BHEL DOCUMENTS NO.: PE-TS-367-174-14000A-A001	
	REV. NO. 01	DATE: 24/02/2014

**CONTENTS**  
**VOLUME-IIB & III**  
**VOLUME-IIB**

SECTION	DESCRIPTION	PAGE NO.
SECTION – A	SCOPE OF ENQUIRY	1
SECTION – B	PROJECT INFORMATION	3
SECTION – C	SPECIFIC TECHNICAL REQUIREMENTS	6
SECTION – C1	• SPECIFIC TECHNICAL REQUIREMENTS FOR MECHANICAL	7
ANNEXURE-I	• LIST OF DRAWING / DOCUMENTS TO BE SUBMITTED AFTER AWARD OF CONTRACT	10
ANNEXURE-II	• CLARIFIED WATER ANALYSIS & COOLING TOWER PARAMETERS	14
ANNEXURE-III	• POTABLE WATER ANALYSIS	16
ANNEXURE-IV	• LIST OF INDICATIVE SUB VENDOR LIST	17
ANNEXURE-V	• PAINTING SCHEME DETAILS	23
ANNEXURE-VI	• DRAWING / DOCUMENT DISTRIBUTION SCHEDULE	27
ANNEXURE-VII	• P&ID	28
ANNEXURE-VIII	• DATASHEET -A	30
ANNEXURE- IX	• QUALITY PLAN	35
SECTION – C2	• SPECIFIC TECHNICAL REQUIREMENTS FOR ELECTRICAL	52
	• ELECTRICAL SCOPE BETWEEN BHEL AND VENDOR	54
	• ELECTRICAL LOAD FORMAT	57
	• QAP FOR MOTORS	59
SECTION – C3	• SPECIFIC TECHNICAL REQUIREMENTS FOR C&I	71
	• PLC SYSTEM CONFIGURATION DIAGRAM	74
	• QUALITY PLAN FOR PLC SYSTEM	76
	• QUALITY PLAN FOR C&I ITEMS	85
	• SPECIFIC TECHNICAL REQUIREMENT FOR C&I ITEMS	99
SECTION – D	GENERAL TECHNICAL REQUIREMENT	124
SECTION – D1	• GENERAL TECHNICAL REQUIREMENT FOR MECHANICAL	125
	• GENERAL TECHNICAL REQUIREMENTS FOR ELECTRIC HOIST	133
SECTION – D2	GENERAL TECHNICAL REQUIREMENT FOR ELECTRICAL	137
	• GENERAL TECHNICAL REQUIREMENT FOR MOTORS	138
	• DATA SHEET – C OF MOTORS	145
	• GENERAL TECHNICAL REQUIREMENTS FOR CABLES	148
	• GENERAL TECHNICAL REQUIREMENTS FOR PANELS, CABINETS & MISCELLANEOUS ELECTRICAL EQUIPMENTS	155
SECTION – D3	GENERAL TECHNICAL REQUIREMENT FOR C&I	159
	GENERAL TECHNICAL REQUIREMENTS FOR INSTRUMENTS	161
	GENERAL TECHNICAL REQUIREMENTS FOR PLC	194
ANNEXURE-X	TG EQUIPMENT LAYOUT PLAN AT EL. 0.0M	211
ANNEXURE-XI	PLOT PLAN	212

**VOLUME-III**

LIST OF SCHEDULE	213
UNPRICED SCHEDULE	214
COMPLIANCE CUM CONFIRMATION SCHEDULE	215
DEVIATION SHEET (COST OF WITHDRAWL)	216
SCHEDULE OF DECLARATION	217



**TITLE:**  
**TECHNICAL SPECIFICATION FOR  
OZONE GENERATION PLANT**  
  
**1X700 MW BELLARY THERMAL POWER  
STATION UNIT NO. 3, STAGE-3**

BHEL DOCUMENTS NO.: PE-TS-367-174-14000A-A001

VOLUME II-B

SECTION -A

REV. NO. 01

DATE: 24/02/2014

**SECTION - A**  
**(SCOPE OF ENQUIRY)**



**TITLE:**  
**TECHNICAL SPECIFICATION FOR  
OZONE GENERATION PLANT**  
**1X700 MW BELLARY THERMAL POWER  
STATION UNIT NO. 3, STAGE-3**

BHEL DOCUMENTS NO.: PE-TS-367-174-14000A-A001

VOLUME II-B

SECTION -A

REV. NO. 01

DATE: 24/02/2014

**1.0 SCOPE:**

- 1.1 This specification is intended to cover design, engineering, manufacturing, painting, inspection & testing, supply, delivery, installation, packing and forwarding of equipments to site, loading, unloading, storage and handling at site, in site transportation, complete with all accessories including start up and commissioning spares, site testing, erection, testing & commissioning, trial run, performance guarantee test and handing over to customer the **OZONE GENERATION PLANT** for **1X700 MW BELLARY THERMAL POWER STATION UNIT NO. 3, STAGE-3**. The scope of supply shall fully cover the requirement of the Design Criteria and Technical Specification of this specification.
- 1.2 It is not the intent to specify all the details of the design & manufacturer. However, the equipment shall conform in all respect to high standard of design, engineering, & workmanship and shall be capable of performing the required duties in a manner acceptable to Engineer / Owner, who will interpret the meaning of drawing & the specification & shall be entitled to reject any work or material, which is not in full accordance herewith.
- 1.3 Items though not specifically mentioned but needed to make the system complete as stipulated under these specifications are also to be included in the specification unless otherwise specifically excluded.
- 1.4 The omission of specific reference to any component/accessory necessary for the proper performance of Ozone Generation Plant shall not relieve the bidder of the responsibility of providing such facilities to complete the supply of equipment at quoted prices.
- 1.5 BHEL's / Customer's representative shall be given full access to the shop in which the equipments are being manufactured or tested and all test records shall be made available to him.
- 1.6 In case of any deviation, the Bidder shall indicate the same clause by clause in the deviation schedule attached with the specification duly filling all the information as per deviation schedule. In the absence of the same it will be construed that the bid conform strictly to the specification.
- 1.7 In case of any contradiction between two clauses / requirements of the specification, bidder to point out those contradictions during pre-bid clarification stage else BHEL / Customer interpretation shall be followed without any commercial & delivery implication to BHEL/Customer after award of contract.
- 1.8 General terms & conditions instructions to the bidder and other attachments referred to elsewhere, make part of tender specification. The bidder shall be responsible for all governed by requirements stipulated hereinafter.
- 1.9 In case of any data/requirement stipulated in the drawings but not in the specification and vice-versa, such data/requirement shall be deemed to be contained in the both. Contradictions between drawings and specification, if any, shall be brought to the attention of the BHEL by the bidder during pre-bid and the correct requirement shall be obtained else BHEL interpretation shall prevail without any commercial & delivery implication to BHEL/Customer.
- 1.10 The equipments covered under this specification shall not be dispatched unless the same have been finally inspected, accepted and shipping release issued by BHEL/Customer.
- 1.11 Un priced copy of the price bid in BHEL format only shall be furnished along with the technical bid.



TITLE:

**TECHNICAL SPECIFICATION FOR  
OZONE GENERATION PLANT  
1X700 MW BELLARY THERMAL POWER  
STATION UNIT NO. 3, STAGE-3**

BHEL DOCUMENTS NO.: PE-TS-367-174-14000A-A001

VOLUME-IIB

SECTION -B

REV. NO. 01

DATE: DATE: 24/02/2014

**SECTION B  
PROJECT INFORMATION**



TITLE:

TECHNICAL SPECIFICATION FOR  
OZONE GENERATION PLANT  
1X700 MW BELLARY THERMAL POWER  
STATION UNIT NO. 3, STAGE-3

BHEL DOCUMENTS NO.: PE-TS-367-174-14000A-A001

VOLUME-IIB

SECTION -B

REV. NO. 01

DATE: DATE: 24/02/2014

- 1.0 Owner : Karnataka Power Corporation Ltd  
Shakthi Bhavan  
No.82, Race Course Road  
Bangalore-560 001  
Karnataka, India
- 2.0 Project Title : 1x700 MW Bellary Thermal Power Station Unit No3,  
Stage-3
- 3.0 Location : **Kudatini Village  
Bellary Dist  
Karnataka state INDIA**
- 4.0 Latitude and Longitude : 15° 11' 58" N Latitude  
76° 43' 23" E Longitude
- 5.0 Elevation above mean sea level : 478 meters
- 6.0 Climatic Conditions
- (a) Temperature
- i. Monthly basis
- Mean of daily maximum temperature : 42.5° C (in the month of April)
- Mean of daily minimum temperature : 19.5° C ( in the month of Dec )
- ii. Monthly basis
- Mean of daily maximum : 37.5° C
- Mean of daily minimum : 19.5° C
- iii Highest temperature recorded : 42.5° C
- iv Lowest temperature recorded : 14.6° C
- (b) Relative Humidity : Varies between 11% and 70%
- (c) Rainfall
- Annual average rain : 492 to 846 mm most of which occurs during August to October6
- (d) Wind Speed
- 1 Annual mean wind speed : 8.4 km / hr
- 2 Maximum mean wind speed : 19 km / hr in the month of July.
- 7.0 Wind Load
- (a) Basic wind speed of 39 m/sec as given in Fig.1 of the code.
- (b) Factor K1 shall be taken as 1.06
- (c) Terrain category shall be 2 and corresponding values shall be taken for K2
- (d) Factor K3 shall be taken as 1.0
- 8.0 Wind Loading for Stack
- (a) For wind pressure as per clause 8.0 above
- (b) For RC stacks as per IS: 4998
- 9.0 Seismic data (as per IS:1893 latest issue)
- (a) Zone : Zone III
- (b) Importance factor (I) : 2.5 for electrical equipment 1.5 for others.



TITLE:

**TECHNICAL SPECIFICATION FOR  
OZONE GENERATION PLANT  
1X700 MW BELLARY THERMAL POWER  
STATION UNIT NO. 3, STAGE-3**

BHEL DOCUMENTS NO.: PE-TS-367-174-14000A-A001

VOLUME-IIB

SECTION -B

REV. NO. 01

DATE: DATE: 24/02/2014

- 10.0 Auxiliary power supply : Auxiliary electrical equipment to be supplied against this specification shall be suitable for operation on the following supply system.
- (a) For motors rated above 175 kW : 11000V, 3 phase, 3 wire, 50Hz medium earthed AC  
3300V, 3 phase, 3 wire, 50Hz medium earthed AC
- (b) For motor control centre : 415V, 3 phase, 3 wire solidly earthed AC
- (c) For motor rated 175 kW and below : 415, 3 phase, 3 wire solidly earthed AC
- (d) DC. motor starters, DC solenoids, DC alarm, control and protections : 220 V DC, 2 wire, unearthed DC
- (e) AC control & protective devices : 110 V 1 phase, 50Hz, 2 wire AC supply. The single-phase 110V AC supply shall be derived by Contractor by providing 415V/110V control transformers of adequate rating with MCCB /MCB on both the primary and secondary sides.
- (f) Uninterrupted power supply : 110 V, 1 phase, 50Hz, 2 wire AC supply from UPS system for I&C (including indicator recorders) and UCMS only
- (g) AC solenoids, indicators/recorders, space heaters (for motors rated 30KW and above) : 240V 1 phase, 2 wire, 50Hz AC system with effectively earthed neutral. The power supply shall be derived by Contractor by providing 415V/ 240V transformer of adequate rating with MCCB/MCB on primary/secondary sides.
- (h) Winding heating of motors below 30kW : 24 V 1 phase, 50Hz, AC with one point earthed. This shall be derived by Contractor by providing 415V 3 phase, 3 wire, AC supply through an adequately rated step-down transformer of adequate rating with MCCB / MCB on primary/secondary sides.
- (i) Solid state controls (including solenoid valves) : 24 V DC, 2 wire, supply from Battery chargers for instrumentation system only.
- (j) Lighting fixtures : 240 V, 1 phase, 2 wire, 50Hz system.
- (k) Lighting fixtures and space heaters in panels : 240 V, 1 phase, 2 wire, 50Hz system.
- (l) Construction supply : 415 V, 3 phase, 4 wire, 50 Hz AC supply with neutral lead solidly earthed. .
- (m) The above voltages may vary as follows:  
All devices shall be suitable for continuous operation over the entire range of voltage and frequency indicated below without any change in their performance.
- i. AC supply : Voltage variation  $\pm 10\%$   
Frequency variation  $\pm 5\%$   
Combined voltage & frequency variation  $\pm 10\%$
- ii. DC supply : Voltage variation  $+10\% -20\%$



**TITLE:**

**TECHNICAL SPECIFICATION FOR  
OZONE GENERATION PLANT**

**1X700 MW BELLARY THERMAL POWER  
STATION UNIT NO. 3, STAGE-3**

BHEL DOCUMENTS NO.: PE-TS-367-174-14000A-A001

VOLUME II-B

SECTION -C

REV. NO. 01

DATE: 24/02/2014

## **SECTION – C**

### **SPECIFIC TECHNICAL REQUIREMENTS**

**C1: SPECIFIC TECHNICAL REQUIREMENTS FOR MECHANICAL**

**C2: SPECIFIC TECHNICAL REQUIREMENTS FOR ELECTRICAL**

**C3: SPECIFIC TECHNICAL REQUIREMENTS FOR C&I**



**TITLE:**

**TECHNICAL SPECIFICATION FOR  
OZONE GENERATION PLANT**

**1X700 MW BELLARY THERMAL POWER  
STATION UNIT NO. 3, STAGE-3**

BHEL DOCUMENTS NO.: PE-TS-367-174-14000A-A001

VOL- IIB

SECTION-C1

REV. NO. 01

DATE: 24/02/2014

**SECTION – C1**

**SPECIFIC TECHNICAL REQUIREMENTS-MECHANICAL**



**TITLE:**  
**TECHNICAL SPECIFICATION FOR  
OZONE GENERATION PLANT**  
**1X700 MW BELLARY THERMAL POWER  
STATION UNIT NO. 3, STAGE-3**

BHEL DOCUMENTS NO.: PE-TS-367-174-14000A-A001  
VOL- IIB  
SECTION-C1  
REV. NO. 01      DATE: 24/02/2014

## 1.0 GENERAL

The Ozone generation plant and associated accessories shall conform to the technical specification.

## 2.0 SCOPE OF SUPPLY

Broad scope of work of this package includes all equipment and accessories as listed under. Please refer Electrical and C&I sections also for respective scopes.

The Ozone generation plant, as specified in Technical specification, Data sheets, P&ID, and shall consist of at least the followings and shall be in the scope of the bidder:

- 2.1 Entire Ozone generation plant of 18 Kg/Hr capacity as per P&ID (PE-DG-367-174-14000A-A001 Rev 01), Data Sheet-A and technical specification requirements.
- 2.2 Oxygen generation plant consist of at least the following:
  - 2.2.1 Three numbers (3) nos. (2 working + 1 standby) Screw type air cooled compressors complete with drive motors, silencer, Intake filters, inter coolers, after coolers, step up gear box, moisture separator, ducting arrangement and other accessories.
  - 2.2.2 One (01) no. unit air receiver of 3 M<sup>3</sup> capacity (minimum) with all accessories.
  - 2.2.3 Two nos (2x100%) Air driers unit per stream (Total 4 numbers for two streams) with all accessories.
  - 2.2.4 Two nos (2x100%) Oxygen generators/concentrator per stream (Total 4 numbers for two streams) with all accessories.
  - 2.2.5 Two nos (2x50%) Oxygen receiver of 2.5 M<sup>3</sup> capacity (minimum) each (One number per stream) with all accessories.
- 2.3 Ozone generator with N (working) + 0 (standby) configuration with all accessories along with transformers, rectifiers, VFD etc. Total capacity of Ozone generator = 18 Kg/hr.
- 2.4 Cooling water plant consist of at least the following:
  - 2.4.1 Two nos (2X100%) chilled water re circulation pumps complete with drive motors along with strainers, instruments, isolation valves, piping, flanges, pipe fittings etc.
  - 2.4.2 Two numbers (2X100%) air cooled chillers with all accessories.
  - 2.4.3 One number potable water storage tanks of 8M<sup>3</sup> capacity (minimum) with all accessories.
- 2.5 Ozone dosing system consist of two numbers (2X100%) Ozone dosing pumps complete with drive motors along with strainers, instruments, injector, isolation valves, piping, Ozone static mixtures as required in the pipe line, flanges, pipe fittings alongwith accessories as required.
- 2.6 Motive water line of 300 meters piping length.
- 2.7 Ozonated water dosing line of 350 meters piping length.
- 2.8 All tanks complete with inlet and outlet connections, all fittings, flanges and appurtenances etc. as specified and as required.
- 2.9 PLC based control system.
- 2.10 Electrical scope shall be as per "Electrical scope between BHEL and Vendor" enclosed with the technical specification.
- 2.11 All necessary drains, vents, and sampling points, with valves, as specified and as required.
- 2.12 Hangers and supports as per the requirement.
- 2.13 All Instrumentation (minimum) as per the enclosed P&ID (PE-DG-367-174-14000A-A001 Rev01) including the electronic on line dew point transmitter, Ozone analyzer, Oxygen purity analyzer, Ozone leak detector, residual ozone analyser, Ozone destructor (if applicable) etc. with suitable sampling connection and isolation valve
- 2.14 Safety requirement as applicable.
- 2.15 Air conditioning and ventilation system.
- 2.16 Commissioning spares as required.
- 2.17 All special tools necessary for proper maintenance or adjustment of the equipment packed in permanent box.
- 2.18 Oil & lubricants for consumption during the commissioning, trial operation.
- 2.19 Painting as per enclosed painting schedule (Annexure-V). However, any variation in the painting schedule as finally approved by customer shall be taken care by the bidder without any commercial and delivery implication.
- 2.20 Finish paints for touch up painting of equipments after erection at site in sealed container.
- 2.21 Initial charge of all lubricants and grease.



**TITLE:**  
**TECHNICAL SPECIFICATION FOR  
OZONE GENERATION PLANT**  
**1X700 MW BELLARY THERMAL POWER  
STATION UNIT NO. 3, STAGE-3**

BHEL DOCUMENTS NO.: PE-TS-367-174-14000A-A001

VOL- IIB

SECTION-C1

REV. NO. 01

DATE: 24/02/2014

- 2.22 Monitoring gadgets, instruments, and equipments required for maintenance (till performance guarantee test and plant handover).
- 2.23 All blank flanges/counter flanges, isolations valves, tees etc. to interconnect the pipes and all terminal points.
- 2.24 All handling facilities including electric hoist.
- 2.25 Softeners if required.
- 2.26 All necessary structural steel for pipe supporting structure, platforms, walkways / pathways and access stairs, mechanical plant and equipment, mechanical services and pipe work associated with Ozone generation Plant.
- 2.27 Permanent ladder (not rungs) for approaching the top of tanks & valves. All steel inserts with lugs, plates, bolts, nuts, sleeves, edge angles and all other embedding components etc as required to grout in civil works and to support/hold the equipments being supplied under this specification for opening/maintenance purpose.
- 2.28 All auxiliary steel structures (U-clamps, nuts, bolts, channels etc.) for fixing the pipe on the pedestal or trestles.
- 2.29 Wrapping, coating and protection of the buried piping.
- 2.30 Recommended spares for three years normal operation (optional item).

### 3.0 SCOPE OF SERVICE

The bidder's scope also includes following services for scope under this specification:

- 1) Transportation of equipments, packing & forwarding, Erection and commissioning, unloading, storage and handling at site.
- 2) In site transportation.
- 3) Arrangement of all instruments and lab facilities to carry out trial run/commissioning and performance guarantee test.
- 4) Complete grouting for equipment, fixing and any concreting inside the vessels and lining.
- 5) All personnel required during commissioning, trial run and performance guarantee test.
- 6) Final touch up paint at site.

### 4.0 TERMINAL POINT

- 4.1 Service water line: At 20 meters from Ozone generation plant building. Further distribution of service water is in bidder's scope.
- 4.2 Potable water (RO water) line: At 20 meters from Ozone generation plant building. Further distribution of potable water is in bidder's scope. The Potable water analysis (Annexure – II) has been attached elsewhere in the specification.
- 4.3 Motive water line: The tap off of 250 NB in ACW system for motive water line for Ozone generation plant shall be provided by BHEL. Further piping from the tap off upto the ozone generation plant is in bidder's scope. The piping distance between tap off to Ozone generation Plant building is 300 meters. Further all the piping inside the building as per system requirement shall be in bidder's scope also.
- 4.4 Instrument air line: At 20 meters from Ozone generation plant building. Further distribution of instrument air is in bidder's scope. The pressure of instrument air shall be 5-8 kg/cm<sup>2</sup> (g).
- 4.5 Ozonated water dosing line from each dosing pump in Ozone generation plant upto Condenser inlet and outlet dosing point is also in bidder' scope. The piping distance from Ozone generation building to dosing point in the Condenser inlet and outlet dosing point is 350 meters & in bidder's scope. Further all the piping inside the building as per system requirement shall be in bidder's scope also.
- 4.6 All drains: Drains from all the systems shall be terminated at one point.

### 5.0 QP AND SUB VENDOR APPROVAL

- 5.1 Minimum QP requirements part of section-C1 shall be as per the enclosed QP (Annexure – IX) subject to BHEL/CUSTOMER approval. However, any additional comments as given by BHEL/CUSTOMER shall be adhered by the bidder without any commercial and delivery implication to BHEL. The cost of third party inspection for all imported components shall also be in bidder's scope.
- 5.2 The sub vendor list (Annexure- IV) enclosed is indicative only and is subject to approval / acceptance by customer. Bidder to propose his sub vendor list with back up documents (experience list, end user performance certificate as applicable) etc. The same shall subject to BHEL and Customer approval during detailed engineering stage without any commercial & delivery implication to BHEL.



**TITLE:**  
**TECHNICAL SPECIFICATION FOR  
 OZONE GENERATION PLANT**  
**1X700 MW BELLARY THERMAL POWER  
 STATION UNIT NO. 3, STAGE-3**

BHEL DOCUMENTS NO.: PE-TS-367-174-14000A-A001	
VOL- IIB	
SECTION-C1	
REV. NO. 01	DATE: 24/02/2014

**6.0 DESIGN/CONSTRUCTION**

In addition to the requirements of Section-C & D the following shall also be complied under scope of this specification:

The P&ID is enclosed herein in this section for bidder's compliance.

The material of construction specified in Data Sheet-A are minimum requirements and material of construction for other components not specified shall be similarly selected by the bidder for intended duty which shall be subjects to customer approval during detailed engineering.

The technical specification requirement for items which are not included shall be subject to customer/BHEL approval during detailed engineering stage. Vendor will submit all the back up documents for proveness of the technical details selected.

**7.0 DRAWING/DOCUMENTS REQUIREMENT**

After award of LOI, following minimum drawing/documents shall be submitted by the bidder for BHEL/Customer approval. However any additional drawing/document if found necessary for completion of the engineering, the same shall be submitted by bidder without any commercial & delivery implication to BHEL.

For the Drawings/Documents Submission Procedure, please refer following Annexure-I. Bidder has to submit the revised drawing/document along with the compliance sheet indicating enumerate reply to all BHEL and customer comments or observations. Without compliance sheet the submission of the drawings/documents will not be considered and the delay on this account will be solely on bidder's side only. The number of drawing/documents to be submitted by the bidder shall be as per enclosed Annexure-VI.

Every revised submission incorporating comments shall be resubmitted within 7 days.

BHEL shall provide observation / approval within 15 days from the date of document submission by bidder.

Bidder to note that drawings submitted shall be complete in all respects with revised drawing submitted incorporating all comments. Any incomplete drawing submitted shall be treated as non-submission with delays attributable to bidder's account. Engineering meeting shall be held fort nightly, for which the bidder shall depute his concerned engineers along with project manager to PEM office or at customer office without fail.

**ANNEXURE - I**

SL. NO.	BHEL DRAWING/ DOCUMENT NUMBER	DRAWING/ DOCUMENT TITLE	NO. OF WEEKS FOR DRAWING/ DOCUMENT SUBMISSION AFTER PLACING LOI/PO	SIZE OF DRAWING/ DOCUMENT
1.	PE-V13-367-174-14000A-A001	PIPING & INSTRUMENTATION DIAGRAM	4	A0
2.	PE-V13-367-174-14000A-A002	PROCESS DESIGN BASIS AND SIZING CALCULATION	4	A4
3.	PE-V13-367-174-14000A-A003	EQUIPMENT LAYOUT	6	A0
4.	PE-V13-367-174-14000A-A004	SUB VENDOR LIST & INSPECTION CRITERIA	4	A4
5.	PE-V13-367-174-14000A-A005	CONTROL PHILOSOPHY WITH PLC SYSTEM CONFIGURATION DIAGRAM	4	A4
6.	PE-V13-367-174-14000A-A006	CIVIL ASSIGNMENT DRAWING	8	A0
7.	PE-V13-367-174-14000A-A007	ELECTRICAL LOAD LIST	8	A4
8.	PE-V13-367-174-14000A-A008	PIPING LAYOUT	8	A0



**TITLE:**  
**TECHNICAL SPECIFICATION FOR  
 OZONE GENERATION PLANT**  
**1X700 MW BELLARY THERMAL POWER  
 STATION UNIT NO. 3, STAGE-3**

BHEL DOCUMENTS NO.: PE-TS-367-174-14000A-A001

VOL- IIB

SECTION-C1

REV. NO. 01

DATE: 24/02/2014

9.	PE-V13-367-174-14000A-A009	DATASHEET & SLD FOR UPS, UPS SIZING CALCULATIONS, BATTERY SIZING CALCULATIONS	10	A4
10.	PE-V13-367-174-14000A-A010	TECHNICAL DATA SHEET OF HORIZONTAL PUMPS	8	A4
11.	PE-V13-367-174-14000A-A011	TECHNICAL DATA SHEET OF COMPRESSORS	8	A4
12.	PE-V13-367-174-14000A-A012	GA & DATA SHEET OF MOTORS	8	A4
13.	PE-V13-367-174-14000A-A013	QAP FOR HORIZONTAL PUMPS WITH MOTOR	4	A4
14.	PE-V13-367-174-14000A-A014	QAP FOR COMPRESSORS WITH MOTOR	4	A4
15.	PE-V13-367-174-14000A-A015	DATA SHEET FOR INSTRUMENTS AND ANALYSER ALONG WITH INSTRUMENT HOOK UP DRAWING	8	A4
16.	PE-V13-367-174-14000A-A016	DATASHEET & GA OF OZONE GENERATOR	8	DATASHEET - A4, GA- A2
17.	PE-V13-367-174-14000A-A017	QAP OF OZONE GENERATOR	4	A4
18.	PE-V13-367-174-14000A-A018	GA OF ATMOSPHERIC TANKS	8	A2
19.	PE-V13-367-174-14000A-A019	GA OF PRESSURE VESSELS	4	A2
20.	PE-V13-367-174-14000A-A020	MECHANICAL DATASHEET & GA FOR AIR DRIER, OXYGEN GENERATOR, CHILLER, VENTURI INJECTOR ETC.	8	DATASHEET - A4, GA- A2
21.	PE-V13-367-174-14000A-A021	MECHANICAL DATASHEET & GA FOR STRAINERS & VALVES	10	A4
22.	PE-V13-367-174-14000A-A022	DATASHEET FOR SAFETY ITEMS	10	A4
23.	PE-V13-367-174-14000A-A023	INSTRUMENT SCHEDULE	10	A4
24.	PE-V13-367-174-14000A-A024	VALVE SCHEDULE	10	A4
25.	PE-V13-367-174-14000A-A025	PLC DOCUMENTS , GA & WIRING DETAILS OF PLC PANEL, I/O LIST, BOM, MIMIC DIAGRAM, PLC CONTROL SCHEMES (BLOCK LOGIC), CONTROL DESK LAYOUT / GA DRAWING, PLC HEAT DISSIPATION DATA ALONG WITH PROCESS GRAPHIC MANUSCRIPTS, PANEL & ELECTRONIC EARTHING REQUIREMENT, PLC CATALOGUE, PLC OWS/PRINTER FURNITURE BOM	12	A4 & A2 AS REQUIRED.
26.	PE-V13-367-174-14000A-A026	LIST OF SOFT SIGNAL EXCHANGE WITH DDCMIS & FIELD JB TERMINATIONS	12	A4
27.	PE-V13-367-174-14000A-A027	PROCESS GRAPHIC MANUSCRIPTS PLC & DDCMIS		
28.	PE-V13-367-174-14000A-A028	QAP AND FAT PROCEDURE FOR PLC	4	A4
29.	PE-V13-367-174-14000A-A029	CABLE TRAY LAYOUT	10	A1
30.	PE-V13-367-174-14000A-A030	QAP / ICL OF OZONE GENERATION PLANT (BALANCE OF ITEMS)	4	A4
31.	PE-V13-367-174-14000A-A031	DESIGN CALCULATION AND DATASHEET OF VENTILATION FANS.	8	A4



**TITLE:**  
**TECHNICAL SPECIFICATION FOR  
 OZONE GENERATION PLANT**  
**1X700 MW BELLARY THERMAL POWER  
 STATION UNIT NO. 3, STAGE-3**

BHEL DOCUMENTS NO.: PE-TS-367-174-14000A-A001

VOL- IIB

SECTION-C1

REV. NO. 01

DATE: 24/02/2014

32	PE-V13-367-174-14000A-A032	DESIGN CALCULATION AND DATASHEET OF AIR CONDITIONERS	8	A4
33	PE-V13-367-174-14000A-A033	QUALITY PLAN FOR ELECTRIC HOIST	8	A4
34	PE-V13-367-174-14000A-A034	GA DRAWING FOR ELECTRIC HOIST	8	A2
35	PE-V13-367-174-14000A-A035	ELECTRIC CIRCUIT DIAGRAM FOR ELECTRIC HOIST	8	A4
36	PE-V13-367-174-14000A-A036	SIZING CALCULATIONS FOR ELECTRIC HOIST	8	A4
37	PE-V13-367-174-14000A-A037	DOWN SHOP LEAD ARRANGEMENT OF ELECTRIC HOIST FOR STRAIGHT PATH	8	A4
38	PE-V13-367-174-14000A-A038	ERECTION PROCEDURE	8	A4
39	PE-V13-367-174-14000A-A039	CABLE SCHEDULE, SUBMISSION OF CABLE INTERCONNECTION DIAGRAM ALONG WITH FIELD JUNCTION BOX TERMINATIONS	10	A4
40	PE-V13-367-174-14000A-A040	PAINTING SCHEDULE	8	A4
41	PE-V13-367-174-14000A-A041	ENGINEERING BOQ	10	A4
42	PE-V13-367-174-14000A-A042	IPG TEST PROCEDURE	12	A4
43	PE-V13-367-174-14000A-A043	O&M MANUAL	12	A4,A2,A1,A0 AS REQUIRED.

**8.0 DRAWING/DOCUMENTS REQUIRED ALONG WITH THE BID (Please also refer Electrical and C&I portion).**

- Deviation schedule (in strictly BHEL Format only) duly fill for deviation, if any.
- Equipment lay out (for information only).
- Un Price Schedule duly filled.
- Compliance cum confirmation schedule.

Documents other than above shall not be reviewed and the same shall be considered as null and void.

**9.0 EXCLUSIONS**

9.1 Potable water, service water and motive water.

9.2 All Civil works at site. However the civil assignment drawing/civil input shall be submitted by the bidder.

**NOTE-1:** - Any item/work either supply of equipment or erection material which have not been specifically mentioned but are necessary to complete the works for trouble free and efficient operation of the plant shall be deemed to be included within the scope of this specification. The bidder without any extra charge shall provide the same.

**NOTE-2:** All drawings/documents shall be approved by BHEL/Customer during detailed engineering stage. Successful vendor shall comply with the comment of the customer/BHEL without price & delivery implication.

**NOTE-3:** Site facility as available or as extended by Customer shall only be provided.

**NOTE-4:** Bidder shall demonstrate the parameters as per the specification requirement to the satisfaction of Customer. The exact modalities of verifying testing of the parameters indicated in the specification shall be finally as agreed with the BHEL/ Customer during detailed engineering & mutually agreed.

**TITLE:****TECHNICAL SPECIFICATION FOR  
OZONE GENERATION PLANT****1X700 MW BELLARY THERMAL POWER  
STATION UNIT NO. 3, STAGE-3**

BHEL DOCUMENTS NO.: PE-TS-367-174-14000A-A001

VOL- IIB

SECTION-C1

REV. NO. 01

DATE: 24/02/2014

**NOTE-5:** Bidder to note that drg/doc submission shall be through web based Document Management System. Bidder would be provided access to the DMS for drg/doc approval and adequate training for the same. Detailed methodology would be finalized during the kick-off meeting. Bidder to ensure following at their end.

- a. Internet explorer version – Minimum Internet Explorer 7
- b. Internet speed – 2 mbps (Minimum preferred)
- c. Pop ups from our external DMS IP (124.124.36.198) should not be blocked
- d. Vendor's Internal proxy setting should not block DMS application's link  
(<http://124.124.36.198/wrenchwebaccess/login.aspx>)



**TITLE:**  
**TECHNICAL SPECIFICATION FOR  
 OZONE GENERATION PLANT**  
**1X700 MW BELLARY THERMAL POWER  
 STATION UNIT NO. 3, STAGE-3**

BHEL DOCUMENTS NO.: PE-TS-367-174-14000A-A001  
 VOL- IIB  
 SECTION-C1  
 REV. NO. 01      DATE: 24/02/2014

**DESIGN RAW WATER ANALYSIS      ANNEXURE –II**

SI.No	Description	Unit	Water Quality Considered for design
<b>Physical Parameters</b>			
1	pH		7.5-8.5
2	Temperature	Deg. C	30
3	Conductivity	mic.mhos/cm	1980
4	Total Suspended Solids	mg/l	100.0
5	Total Dissolved Solids	mg/l	1500 (max)
6	Turbidity	NTU	51.0
7	Oil & grease	mg/l	Nil
<b>Chemical Parameters</b>			
8	Calcium as Ca	mg/l	50.0
9	Magnesium as Mg	mg/l	40.0
10	Sodium as Na	mg/l	347
11	Potassium	mg/l	5.1
12	Iron - Total (Fe)	mg/l	1.0
13	Alkalinity-m as CaCO3	mg/l	550.0
14	Alkalinity-p as CaCO3	mg/l	50.0
15	Bicarbonate as HCO3	mg/l	671
16	Carbonate as CO3	mg/l	10
17	Sulphate as SO4	mg/l	24.0
18	Chloride as Cl	mg/l	307
19	Silica reactive as SiO2	mg/l	32.0
20	C.O.D	mg/l	60.0
21	Colloidal silica	mg/l	3 to 18
22	Dissolved oxygen	mg/l	5.2
<b>Additional Parameters</b>			
23	BOD	mg/l	8.2
24	TOC	mg/l	12.4
25	Nitrate	mg/l	19.0
26	Ammonia	mg/l	Nil
27	Total Silica	mg/l	22 to 46
28	Zinc	mg/l	0.37
29	Nickel	mg/l	< 0.005
30	Chromium Total	mg/l	0.009
31	Barium	mg/l	Nil
32	Bromide	mg/l	Nil
33	Fluoride	mg/l	0.9



**TITLE:**  
**TECHNICAL SPECIFICATION FOR  
OZONE GENERATION PLANT**  
**1X700 MW BELLARY THERMAL POWER  
STATION UNIT NO. 3, STAGE-3**

BHEL DOCUMENTS NO.: PE-TS-367-174-14000A-A001

VOL- IIB

SECTION-C1

REV. NO. 01

DATE: 24/02/2014

Sl.No	Description	Unit	Water Quality Considered for design
34	Hydrogen Sulphide	mg/l	Nil
35	Manganese	mg/l	0.16
36	Strontium	mg/l	Nil
37	Ammonical Nitrogen	mg/l	<0.1
38	Phosphate	mg/l	1 to 2
	<b>Bacteriological Parameters</b>		
39	Coliforms (e coli)	Cfu/ml	present
40	Feacal Colifrms	Cfu/100ml	86.0
41	Total Viable Count at 48 hrs	Cfu/100ml	$67 \times 10^{-2}$

Clarified water analysis is as follows.

1. Turbidity <20 NTU
2. TSS <20 ppm
3. P<sup>H</sup> 7.5 to 8.5
4. Residual chlorine <0.5 ppm

**A. THE CYCLE OF CONCENTRATION (COC) SHALL BE CONSIDERED AS 5.**

**B. DATA FOR COOLING TOWER:**

- i. Total CW circuit water flow = 82109 Cum/hr.
- ii. Storage/Holdup volume of cooling tower basin=8100 m<sup>3</sup>.
- iii. Temperature difference across cooling tower is 9.8 Deg C.
- iv. MOC of Condenser tube is Ti (ASTM A249 TP304).
- v. Cooling Tower blow down= 354 M3/Hr.



**TITLE:**

**TECHNICAL SPECIFICATION FOR  
OZONE GENERATION PLANT**

**1X700 MW BELLARY THERMAL POWER  
STATION UNIT NO. 3, STAGE-3**

BHEL DOCUMENTS NO.: PE-TS-367-174-14000A-A001

VOL- IIB

SECTION-C1

REV. NO. 01

DATE: 24/02/2014

## **ANNEXURE – II**

### **PORTABLE WATER ANALYSIS**

- 1) RO Permeate TDS: less than 80 ppm at the end of membrane life.**



**TITLE:**  
**TECHNICAL SPECIFICATION FOR  
 OZONE GENERATION PLANT**  
**1X700 MW BELLARY THERMAL POWER  
 STATION UNIT NO. 3, STAGE-3**

BHEL DOCUMENTS NO.: PE-TS-367-174-14000A-A001  
 VOL- IIB  
 SECTION-C1  
 REV. NO. 01      DATE: 24/02/2014

**INDICATIVE SUB VENDOR LIST  
 ANNEXURE - IV**

SL NO.	ITEM	APPROVED SUPPLIERS	PLACE
1.	OIL FREE SCREW COMPRESSOR	ATLAS COPCO	PUNE
		KOBELCO (KPC)	PUNE
		ELGI	COIMBTORE
		INGERSOLL RAND	AHMADABAD
2.	AIR RELEASE VALVES	H.SARKER & COMPANY	
		LEADER VALVES LTD.	
		R&D MULTIPLES (METAL CAST) PVT. LTD.	
		A.V. VALVES LIMITED	
		G.M.DALUI & SONS PVT.LTD.	
3.	MS ROD FOR BELOW GROUND EARTHING	STEEL AUTHORITY OF INDIA LIMITED	
		RASHTRIYA ISPAT NIGAM LIMITED	
4.	CHAIN PULLEY BLOCK	HERCULES HOISTS LTD	
		LIFTING EQUIPMENTS & ACCESSORIES	
		ARMSEL MHE PVT. LTD., BANGALORE	
5.	ELECTRIC HOISTS	AVON CRANES PVT.LTD.	
		EDDYCRANES PVT.LTD.	
		LIFTING EQUIPMENTS & ACCESSORIES	
		REVA INDUSTRIES LTD.	
		CONSOLIDTED HOIST PVT LTD	
		HERCULES HOISTS LTD	
		ARMSEL MHE PVT. LTD.,BANGALORE	
6.	BALL VALVES	AKAY INDUSTRIES PVT.LTD.	
		FLOW CHEM INDUSTRIES	
		FISHER SANMAR LIMITED	
		KIRLOSKAR BROS. LTD.	
		LEADER VALVES LTD.	
		KSB PUMPS LTD.	
		MICROFINISH VALVES PVT LTD.	
		MICON VALVES (INDIA) PVT.LTD	
		PEC VALVES PVT.LTD.	
		VIRGO ENGINEERS LTD.	
		A.V. VALVES LIMITED	
		FLUIDLINE VALVES COMPANY PRIVATE MUMBAI	
		STEELSTRONG VALVES (I) PVT.LTD.,MUMBAI	
		B.D.K. ENGINEERING INDUSTRIES LTD.	
		SURYA VALVES &INSTRUMENTS MANUFACTURING COMPANY, CHENNAI	
		VAL TECH INDUSTRIES ,MUMBAI	
FEDERAL HARDWARE ENGINEERING CO PTE LTD., SINGAPORE			
CRESCENT VALVES MFG. CO. PVT. LTD.			



**TITLE:**  
**TECHNICAL SPECIFICATION FOR**  
**OZONE GENERATION PLANT**  
**1X700 MW BELLARY THERMAL POWER**  
**STATION UNIT NO. 3, STAGE-3**

BHEL DOCUMENTS NO.: PE-TS-367-174-14000A-A001

VOL- IIB

SECTION-C1

REV. NO. 01

DATE: 24/02/2014

7.	CONTROL VALVE	DeZURIK -COPES VULCAN LTD., U.K	
		CONTROL COMPONENT INC., USA	
		DRESSER VALVE INDIA PVT. LTD UP TO 45ksc ONLY	
		FOURESS ENGG.INDIA LTD.UP TO 45ksc ONLY	
		FISHER SANMAR LTD	
		INSTRUMENTATION LTD. UP TO 45ksc ONLY	
		MIL. CONTROLS LTD.	
8.	STEEL GATE /GLOBE/NRV VALVES	A.V. VALVES LTD	
		NITON VALVE INDUSTRIES PRIVATE LTD	
		WEIR VALVES & CONTROLS M.E.	
		BABCOCK BORSIG ESPANA, S.A.	
		B.D.K. ENGINEERING INDUSTRIES LTD.	
		KIRLOSKAR BROTHERS LTD.	
		LEADER VALVES LTD.	
		KSB PUMPS LTD.	
		MICON VALVES (INDIA) PVT. LTD	
		OSWAL INDUSTRIES LTD.	
		PETROL VALVES S.R.L. ITALY	
		FOURESS ENGG. INDIA LTD.	
		FLUIDLINE VALVES COMPANY PRIVATE LTD., MUMBAI	
		STEEL STRONG VALVES (I) PVT. LTD., MUMBAI	
		VALTECH INDUSTRIES ,MUMBAI	
		SURYA VALVES AND INSTRUMENTS MANUFACTURING COMPANY, CHENNAI	
9.	CAST IRON/ GATE/GLOBE/NRV/SAFETY RELIEF VALVES	A.V. VALVES LTD	
		H.SARKER & COMPANY	
		G.M. DALUI & SONS PVT. LTD.	
		KIRLOSKAR BROS. LTD.	
		LEADER VALVES LTD.	
		MICON VALVES (INDIA) PVT. LTD	
		FLUIDLINE VALVES COMPANY PRIVATE	
		FEDERAL HARDWARE ENGINEERING CO PTE LTD., SINGAPORE	
		CRESCENT VALVES MFG. CO. PVT. LTD.	
		SURYA VALVES AND INSTRUMENTS MANUFACTURING COMPANY, CHENNAI	



**TITLE:**  
**TECHNICAL SPECIFICATION FOR  
 OZONE GENERATION PLANT**  
**1X700 MW BELLARY THERMAL POWER  
 STATION UNIT NO. 3, STAGE-3**

BHEL DOCUMENTS NO.: PE-TS-367-174-14000A-A001

VOL- IIB

SECTION-C1

REV. NO. 01

DATE: 24/02/2014

10.	BF VALVES (WATER SERVICE)	ADVANCE VALVES PVT. LTD	
		B.D.K. ENGINEERING INDUSTRIES LTD.	
		INTER VALVE (INDIA) LTD.	
		FOURESS ENGG. INDIA LTD.	
		INSTRUMENTATION LTD.	
		LARSEN & TOUBRO LTD.	
		KIRLOSKAR BROS. LTD.	
		MICON VALVES (INDIA) PVT. LTD	
		R&D MULTIPLES (METAL CAST) PVT. LTD.	
		SURYA VALVES AND INSTRUMENTS MANUFACTURING COMPANY, CHENNAI	
		STAFFORD CONTROLS LIMITED, PUNE	
		FLUIDLINE VALVES COMPANY PRIVATE LTD., MUMBAI	
TYCO VALVES & CONTROLS INDIA PVT.LTD.,HALOL			
11.	A/C SYSTEM	ABB,LTD.	
		BLUE STAR LTD.	
		VOLTAS LTD.	
12.	VENTILATION SYSTEM	ASEA BROWN BOVERI LTD.	
		ALSTOM LTD.	
		BLUE STAR LTD.	
		HYDERABAD POLLUTION CONTROLS LTD.	
		VOLTAS LTD.	
		C. DOCTOR & CO. PVT. LTD.	
13.	FLOW ELEMENT	ENGINEERING SPECIALTIES PRIVATE LTD	
		INSTRUMENTATION LTD.	
		MICRO PRECISION PRODUCTS	
		STAR-MECH CONTROLS (I) PVT.LTD	
14.	PUMPS (HORIZONTAL)	BEST & CROMPTON ENGG. LTD.	
		FLOWMORE LTD.	
		JYOTI LTD.	
		KIRLOSKAR BROS. LTD.	
		MATHER & PLAN PUMPS LTD.	
		KSB PUMPS LTD.	
		SULZER PUMPS INDIA LTD.	
		WPIL LIMITED	
SAM TURBO INDUSTRY LTD.			
15.	PROGRAMMABLE LOGIC CONTROLS	SIEMENS LTD	
		ABB LIMITED	
		SCHNEIDER ELECTRIC INDIA PVT. LTD., NEW DELHI	



**TITLE:**  
**TECHNICAL SPECIFICATION FOR  
 OZONE GENERATION PLANT**  
**1X700 MW BELLARY THERMAL POWER  
 STATION UNIT NO. 3, STAGE-3**

BHEL DOCUMENTS NO.: PE-TS-367-174-14000A-A001  
 VOL- IIB  
 SECTION-C1  
 REV. NO. 01      DATE: 24/02/2014

16.	ROTAMETER	CHEMTROLS SAMIL (INDIA) PVT. LTD., MUMBAI	
17.	DIAPHRAGM VALVE	BDK VALVES –HUBLI CRANE FLOW PROCESS-SATARA	
18.	CHECK VALVES (FLAT TYPE SIZE UPTO 50 NB)	B BDK VALVES –HUBLI H SARKAR-HOWRAH LEADER-JALANDHAR MAJESTIC WORKS, MUMBAI	
19.	DUAL PLATE NON RETURN VALVES (SS & CI UPTO 100 NB CLASS 150)	ADVANCE VALVES-NOIDA R&D MULTIPLES-VALSAD B BDK VALVES –HUBLI	
20.	SOLENOID VALVES	ROTEX AUTOMATION-BARODA ASCO - CHENNAI	
21.	Y-TYPE STRAINER	OTOKLIN-MUMBAI GRAND PRIX-NEW DELHI JAYPEE-NEW DELHI GREAVES COTTON-MUMBAI MULTITEX- NEW DELHI	
22.	MS PIPES (IS: 1239 & 3589)	SAIL-ROUR KELA JINDAL (UPTO 350 NB)-GHAZIABAD TISCO (UPTO 150 NB)-JAMSHEDPUR MSL (FOR IS 3589-200 NB TO 500 NB)- RAIGAD	
23.	MS PLATES	SAIL	
24.	LEVEL GAUGES	SIGMA INSTRUMENTS LEVCON SBEM V. AUTOMAT	MUMBAI KOLKATA PUNE NEW DELHI
25.	LEVEL TRANSMITTER (FOR ULTRA SONIC TYPE)	EMERSON PROCESS MANAGEMENT (I) LTD SIEMENS	
26.	ANALYSERS	POLYTRON HACH ULTRA ABB ORION SWAN EMERSON PROCESS MANAGEMENT	FRANCE FRANCE UK USA USA CHENNAI



**TITLE:**  
**TECHNICAL SPECIFICATION FOR  
 OZONE GENERATION PLANT**  
**1X700 MW BELLARY THERMAL POWER  
 STATION UNIT NO. 3, STAGE-3**

BHEL DOCUMENTS NO.: PE-TS-367-174-14000A-A001  
 VOL- IIB  
 SECTION-C1  
 REV. NO. 01      DATE: 24/02/2014

27.	PRESSURE / DP TRANSMITTER	EMERSON PROCESS MANAGEMENT	USA/DAMAN
		FUJI ELECTRIC	JAPAN
		HONEYWELL	USA
		YOKOGAWA	JAPAN
		ABB	ITALY/FARIDABAD/BANGALORE
28.	PRESSURE AND DIFFERENTIAL PRESSURE GAUGE	A.N.INST	KOLKATTA
		WAREE	MUMBAI
		SWITZER INSTRUMENTS	CHENNAI
		GENERAL INSTRUMENTS CONSORTIUM	GOA / MUMBAI
		MANOMETER	MUMBAI
29.	TEMPERATURE GAUGE	A.N.INST	KOLKATTA
		H.GURU (SI) P LTD	BANGALORE
		GIC	GOA/MUMBAI
		PYRO ELECTRIC INSTRUMENTS P LTD	GOA
30.	TEMPERATURE ELEMENT	GENERAL INST CONSORTIUM	NEW DELHI
		PYRO ELECTRIC	GOA
		TOSHINWAL BROS	NEW DELHI
31.	TEMPERATURE TRANSMITTER	SOR INC	USA
		DELTA CONTROLS LIMITED	USA
		ABB	CHENNAI
32.	PNEUMATIC ACTUATORS (POWER CYLINDER)	INSTRUMENTATION LTD	
		KELTRON CONTROLS	
		ROTEX MANUFACTURERS & ENGINEERS PVT LTD	
33.	LT MOTORS	BBL	MUMBAI
		CGL	MUMBAI/AHEMDABAD
		ALSTOM	KOLKATTA
		KEC	BANGALORE/HUBLI
		SEIMENS	MUMBAI
		ABB	FARIDABAD
34.	UPS	HITACHI	GANDHI NAGAR
		EMERSON PROCESS MANAGEMENT	CHENNAI
35.	AGITATOR/STIRRER	FIBRE & FIBRE	MUMBAI
36.	FITTINGS	BHARAT FORGE	PUNE
		RELIANCE FORGE	PUNE
37.	FLANGES	BHARAT FORGE	PUNE
		RELIANCE FORGE	PUNE
38.	220V DC BATTERY CHARGER	CHHABI ELECTRICALS PVT. LTD.	
		CALDYNE AUTOMATICS LTD.	
		HBL POWER SYSTEMS LTD	
		AFCO INDUSTRIAL AND CHEMICALS LTD.	
		STATCON POWER CONTROLS L. TD.	
		AMARA RAJA POWER SYSTEMS PVT. LTD	



**TITLE:**  
**TECHNICAL SPECIFICATION FOR  
OZONE GENERATION PLANT**  
  
**1X700 MW BELLARY THERMAL POWER  
STATION UNIT NO. 3, STAGE-3**

BHEL DOCUMENTS NO.: PE-TS-367-174-14000A-A001

VOL- IIB

SECTION-C1

REV. NO. 01

DATE: 24/02/2014

39.	220V DC LEAD ACID BATTERIES (TUBULAR AND PLANTE)	EXIDE INDUSTRIES LTD	
		HBL NIFE POWER SYSTEMS LTD.	

**NOTE:** - THE SUB VENDOR LIST ENCLOSED IS INDICATIVE ONLY AND IS SUBJECT TO APPROVAL / ACCEPTANCE BY CUSTOMER BIDDER TO PROPOSE HIS SUB VENDOR LIST WITH BACK UP DOCUMENTS (EXPERIENCE LIST, END USER CERTIFICATE AS APPLICABLE) ETC. THE SAME SHALL SUBJECT TO BHEL AND CUSTOMER APPROVAL DURING DETAILED ENGINEERING STAGE WITHOUT ANY COMMERCIAL & DELIVERY IMPLICATION TO BHEL.



**TITLE:**  
**TECHNICAL SPECIFICATION FOR  
OZONE GENERATION PLANT**  
**1X700 MW BELLARY THERMAL POWER  
STATION UNIT NO. 3, STAGE-3**

BHEL DOCUMENTS NO.: PE-TS-367-174-14000A-A001  
VOL- IIB  
SECTION-C1  
REV. NO. 01      DATE: 24/02/2014

**PAINTING SCHEME DETAILS  
ANNEXURE – V**

**1.0 SCOPE**

1.1 This section covers the painting requirements for the Ozone generation plant as applicable.

**2.0 CODES AND STANDARDS**

Painting of equipment shall be carried out as per the specifications indicated below and shall conform to the relevant IS specification for the material and workmanship.

The following Indian Standards may be referred to for carrying out the painting job:

- IS:5 : Colours for ready mixed paints and enamels
- IS:1303 : Glossary of terms relating to paints
- IS:2379 : Colour code for identification of pipelines
- IS:1477 : Code of practice for painting of ferrous metals in buildings (Parts I & II)
- IS:2524 : Code of practice for painting of non-ferrous metals in buildings (Parts I & II)
- IS:2395 : Code of practice for painting of concrete, masonry and plaster surfaces (Parts I & II)
- IS:2338 : Code of practice for finishing of wood and wood based materials (Parts I & II)
- IS:6278 : Code of practice for white washing and colour Washing
- IS:3140 : Code of practice for painting asbestos cement building products
- IS:158 : Ready mixed paint, brushing, bituminous, black, lead-free, acid, alkali, water and heat resisting
- IS:2074 : Ready mixed paint, air drying, red Oxide Zinc Chrome, priming
- IS:104 : Ready mixed paint, brushing, Zinc Chrome, priming
- IS: 2932 : Enamel , synthetic, exterior  
(a) undercoating  
(b) finishing

**3.0 PREPARTION OF SURFACES**

All surfaces to be painted shall be thoroughly cleaned of all grease, oil, loose mill scale , dust , rust and any other foreign matter. Mechanical cleaning by power tool and scrapping with steel wire brushes shall be adopted to clear the surfaces. However, in certain locations where power tool cleaning cannot be carried out sand scrapping may be permitted with steel wire brushes and /or abrasive paper. Cleaning with solvents shall be resorted to only in such areas where other methods specified above have not achieved the desired results. Cleaning with solvents shall be adopted only after written approval of the CUSTOMER /CUSTOMER RESPRESENTATIVE. The sheet steel of electrical and instrumentation panels shall be pre-treated through chemical cleaning (7 tank) process of rinsing, degreasing, rinsing, derusting, rinsing, phosphating and rinsing. However, in case mechanical cleaning is also required Bidder shall carry out the same to get a smooth finish.

**4.0 PRIMER PAINT**

After the surface is prepared one coat of Zinc Phosphate primer conforming to IS 2074 shall be applied. After this first coat is dried up completely, second coat of primer shall be applied. Primer shall be applied by brushing, spray, roller as per manufacture recommendation to ensure a continuous film. The dry film thickness of each coat shall be as indicated in Annexure-A enclosed. Insulated surfaces will have only primer coating and no finish painting.



**TITLE:**  
**TECHNICAL SPECIFICATION FOR  
OZONE GENERATION PLANT**  
**1X700 MW BELLARY THERMAL POWER  
STATION UNIT NO. 3, STAGE-3**

BHEL DOCUMENTS NO.: PE-TS-367-174-14000A-A001

VOL- IIB

SECTION-C1

REV. NO. 01

DATE: 24/02/2014

## 5.0 FINISH PAINT

Synthetic enamel paint conforming to IS 2932 shall be used for finish coats. The colour /shade shall be as approved by BHEL/Customer. After cleaning the dust on the dried up primer, first coat of synthetic enamel shall be applied. After this first coat dries up hard, the surface is wet scrubbed cutting down to a smooth finish and ensuring that at no place the first coat is completely removed. After allowing the water to get evaporated completely, the second finish coat of synthetic enamel paint shall be applied.

## 6.0 PAINTING AND CORROSION PROTECTION FOR PIPES & FITTINGS

- 6.1 All uninsulated piping systems, hangers and supports shall have two coats of Zinc Phosphate Primer (conforming to IS 2074) and finish paint using synthetic enamel paint to give a finish coat. Shades shall be as per IS 5 or as indicated by BHEL/Customer. Service of the pipeline designations shall be painted on all pipes at visible locations.
- 6.2 Before application of paint, Contractor shall clean the pipes of all mill scale, dirt dust, soot grease, rust etc.
- 6.3 All pipe lines, piping components shall be adequately protected against corrosion during manufacture, fabrication, shipment and storage by appropriate protective paint.
- 6.4 Shop fabricated equipment/items shall be dispatched with final paint. Necessary touch up shall be done at site. Site fabricated equipment/items shall be dispatched with primer painting only and final painting shall be applied at site.

## 7.0 PAINTING AND CORROSION PROTECTION FOR VALVES & SPECIALTIES

Two coats of primer of thickness as indicated in Annexure-A shall be applied to all steel and cast iron exposed surfaces as required to prevent corrosion before dispatch. The use of grease or oil, other than light grade mineral oil, for corrosion protection is prohibited. Bores of all valves shall be covered immediately after testing, draining and drying with suitable plastic end covers to avoid ingress of foreign materials.

## 8.0 Suggested Colour Codes for Painting

Suggested colour codes has been enclosed for adherence. Colour codes for piping shall be as per IS 2379 with necessary modifications. Where band colour is specified for piping, same shall be provided at 30 metre intervals on long uninterrupted lines and also adjacent to valves and junctions.

## 9 PAINTING SCHEDULES

- 9.1 Painting schedules for various systems/ items are furnished as per enclosed Annexures-A . Vendors will furnish detailed painting schedule for customer approval during detail engineering stage as per specification.



**TITLE:**  
**TECHNICAL SPECIFICATION FOR**  
**OZONE GENERATION PLANT**  
**1X700 MW BELLARY THERMAL POWER**  
**STATION UNIT NO. 3, STAGE-3**

BHEL DOCUMENTS NO.: PE-TS-367-174-14000A-A001

VOL- IIB

SECTION-C1

REV. NO. 01

DATE: 24/02/2014

**ANNEXURE - A**

Paint Reference Scheme	Surface Preparation Grade / Surface Profile	Primer Coat			Intermediate Coat			Finish Coat			Total DFT in microns
		Premier Paint	No. of Coats	DFT in Microns	Intermediate Paint	No. of Coats	DFT in Microns	Finish Paint (See Note)	No. of Coats	DFT in Microns	
Various type of equipment /valve, etc. (Temp. upto 90°C)	Degreasing and Mech. Cleaning with wire brushing/hand tool (Sa1/St2/St3 as applicable)	HB Zinc Phosphate (alkyd Medium) as per IS:2074	2	35-45 per coat	- NA	-	-	Synthetic enamel (alkyd med.) as per IS:2932	2	20 – 25 per coat	110 - 140
LP Piping/structurals/ Vessels, etc. (Temp. upto 90°)	- do -	HB Zinc Phosphate as per IS:2074 (alkyd medium)	2	35 – 45 per coat	- NA	-	-	Synthetic enamel (alkyd med.) as per IS:2932	2	20 – 25 per coat	110-140
Equipment with (Temp. upto 250°)	- do -	Heat resistant Al – paint	2	20 per coat	- NA	-	-	NA	Insulated	NA	40
Equipment in corrosive areas.	Blast clean to Sa 2 1/2	HB Epoxy resin based zinc phosphate primer	1	50 per coat	Epoxy based MIO pigmented paint	1	50 per coat	Polyamide cured Epoxy finish coat	2	25 – 35 per coat	150 - 170
Elect. / Control Panels, etc.	Seven tank process	HB Zinc phosphate (alkyd Medium) as per IS:2074	2	35 – 45 per coat	-NA	-	-	Synthetic enamel (alkyd med.) as per IS:2932	2	20 – 25 per coat	110 - 140

**Notes:**

- Surface preparation shown is as per Swedish Standards SIS 05-5900 or equivalent Indian std. Degreasing will be as per Standard SSPC-SP1.
- Incase of insulated surfaces, only primer coats shall be applied.
- GM/SS items with piping and G.I. pipes will not be painted. Further SS/GI piping shall be given necessary colour banding for identification as per colour scheme.
- All instruments shall be painted as per manufacturer standard practice.
- All structural steel items shall be painted at site. Piping shall go with primer coating & finish paint shall be applied at site. Equipment shall be finish painted at shop.
- Method of painting application shall be as per paint manufacturer's recommendation.
- Based on above detailed painting schedule will be prepared by Ozone Generation plant supplier and will be submitted to BHEL for their approval.
- The above mentioned painting requirements are bare minimum. Any variation as required by BHEL/customer during detailed engineering stage shall be adhered by the bidder without any delivery/commercial implication to BHEL.



**TITLE:**  
**TECHNICAL SPECIFICATION FOR  
 OZONE GENERATION PLANT**  
**1X700 MW BELLARY THERMAL POWER  
 STATION UNIT NO. 3, STAGE-3**

BHEL DOCUMENTS NO.: PE-TS-367-174-14000A-A001  
 VOL- IIB  
 SECTION-C1  
 REV. NO. 01      DATE: 24/02/2014

**SUGGESTED COLOUR CODES FOR PAINTING**

SL. NO.	ITEM/SERVICE	COLOUR	IS-5 Grade	COLOUR (BAND)	IS-5
1.0	Structures, platforms, galleries, ladders and handrails	Dark Admiralty Grey	632	-	-
2.0	Crane				
2.1	Crane structure	Golden Yellow	356	-	-
2.2	Trolley and hook	Crimson	540	-	-
3.0	Fans, pumps, motors, compressors	Light Grey	631	-	-
4.0	Tanks (without insulation and cladding)				
4.1	Outdoor	Aluminium	-	-	-
4.2	Indoor	Light grey	631	-	-
5.0	Vessels & all other proprietary equipment (without insulation & cladding)	Light grey	631	-	-
6.0	Control & relay panels	Light grey	631/7078 of IS 1650	-	-
7.0	Transformers	Aluminium	-	-	-
8.0	Machinery guards	Signal red	537	-	-
9.0	Piping				
9.1	Potable, Service water & Ozonated water	Sea green	217	French blue	166
9.2	Compressed air, Oxygen, Ozone, instrument air	Sky blue	101	White	-
9.3	Vacuum pipes	Sky blue	101	Black	-
9.4	Drainage	Black	-	-	-

**Notes:**

1. This colour code basically refers to IS:2379 for piping with necessary modifications
2. Where band colour is specified, same shall be provided at 30 meter intervals on long uninterrupted lines and also adjacent to valves and junctions.
3. The above mentioned painting requirements are bare minimum. Any variation as required by BHEL/customer during detailed engineering stage shall be adhered to the bidder without any delivery/commercial implication to BHEL.



**TITLE:**  
**TECHNICAL SPECIFICATION FOR  
 OZONE GENERATION PLANT**  
**1X700 MW BELLARY THERMAL POWER  
 STATION UNIT NO. 3, STAGE-3**

BHEL DOCUMENTS NO.: PE-TS-367-174-14000A-A001  
 VOL- IIB  
 SECTION-C1  
 REV. NO. 01      DATE: 24/02/2014

**DRAWING / DOCUMENT DISTRIBUTION SCHEDULE**  
**ANNEXURE - VI**

S. NO.	DESCRIPTION	CONSULTANT	KPCL HEAD OFFICE	KPCL SITE	BHEL UNIT	BHEL SITE
A	POST CONTRACT CORRESPONDENCE	1	S	1	1	0
		0	1	S	1	1
		0	1	1	S	1
		0	1	1	1	S
B	<b>DRAWINGS/DOCUMENT SUBMISSION</b>					
	A) SUBMISSION	2	11	2	S	2
	B) RETURN OF SUBMISSION WITH COMMENTS/APPROVAL BY RPCL	1	S	1	2	0
	C) RFC ISSUE	2	11	2	S	4
	D) AS BUILT	2	11	2	S	4
	E) ERECTION DRAWINGS	2	11	3	S	5
C	<b>PROGRESS REPORT (MONTHLY)</b>					
	EPC CONTRACTOR'S REPORT	2	11	5	S	4
D	<b>INSTRUCTION MANUALS</b>					
	ERECTION & COMMISSIONING	2	11	3	S	3
	O & M MANUAL	2	1 + 8CD	5 + 11CD	S	2 + 5CD

**KPCL- KARNATAKA POWER CORPORATION LIMITED**  
**CONSULTANT –TRACTEBEL ENGINEERING PVT. LTD.**  
**S SOURCE**  
**CD SOFT COPY**

Note:

- Quantity of prints may change during detailed engineering stage based on BHEL / Customer requirement. However the same will be adhered by the bidder without any delivery/commercial implication to BHEL.
- Initial submission of drawings / documents will be in soft format (pdf only) through email followed by Thirteen (13) hard copies.
- All the drawing documents along with the O&M manual (of all the revisions) are necessarily to be submitted in soft copies in addition to hard copies.
- All the drawings shall be prepared on computer auto cad and other documents (like datasheet etc.) on MS office software. Bidder not complying to the requirement shall not be considered. For the execution of the contract regular meeting (generally once in 15 days or as per project requirement) is required. Vendor to come for meeting with the concerned dealing persons as per BHEL or customer (RPCL) requirement in a short notice.
- Bidder to also furnish the auto cad copy of the following documents after award of contract. However any other auto cad copy of any other document as per the insistence of BHEL / customer will also be submitted by the bidder without any delivery/commercial implication to BHEL.
  - Equipment lay out.
  - Cable tray lay out.
  - Civil scope drawings.
  - Piping lay out drawing.
- Cable schedule in BHEL format (shall be provided during detailed engineering stage).



**TITLE:**

**TECHNICAL SPECIFICATION FOR  
OZONE GENERATION PLANT**

**1X700 MW BELLARY THERMAL POWER  
STATION UNIT NO. 3, STAGE-3**

BHEL DOCUMENTS NO.: PE-TS-367-174-14000A-A001

VOL- IIB

SECTION-C1

REV. NO. 01

DATE: 24/02/2014

**P & ID  
ANNEXURE - VII**

FIRST ANGLE PROJECTION ALL DIMENSIONS ARE IN MM

**TERMINAL POINT DETAILS**

- TERMINAL POINT #1 - THE TAP OFF OF 200 NB IN C/W SYSTEM FOR MOTIVE WATER LINE FOR OZONE GENERATION PLANT SHALL BE PROVIDED BY BHEL, FURTHER IRING FROM THE TAP OFF UP TO THE OZONE GENERATION PLANT BLDG IS BEEDER'S SCOPE, THE PIPING BEING BETWEEN TAP OFF TO OZONE GENERATION PLANT BUILDINGS - 300 METERS.
- TERMINAL POINT #2 - OZONE DOZING LINE FROM COOLING WATER OZONE GENERATION PLANT UP TO THE CONDENSER INLET AND OUTLET CONNECTION IS ALSO IN BEEDER'S SCOPE, THE PIPING BEING FROM OZONE GENERATION BUILDING TO SING POINT IN THE CONDENSER INLET AND OUTLET DOING POINT 8730 METERS.
- TERMINAL POINT #3 - PORTABLE WATER WATER DOZING LINE FROM COOLING WATER OZONE GENERATION UNIT SHALL BE PROVIDED BY BHEL, FURTHER DISTRIBUTION OF PORTABLE WATER IN BEEDER'S SCOPE.
- TERMINAL POINT #4 - INSTRUMENT AIR LINE AT 20 METERS FROM COOLING WATER OZONE GENERATION PLANT AREA SHALL BE PROVIDED BY BHEL, FURTHER DISTRIBUTION OF INSTRUMENT AIR IS IN BEEDER'S SCOPE.

LEGENDS		
DESCRIPTION	INDICATION	
NON RETURN VALVE	↗	
DOUBLE ACTING PNEUMATIC OPERATOR	⊕	
BALL VALVE	⊠	
BUTTERFLY VALVE	⊞	
GATE VALVE	⊠	
SAFETY RELIEF VALVE	⊖	
PRESSURE GAUGE	⊕	
PRESSURE INDICATOR CUM TRANSMITTER	⊕	
TEMPERATURE GAUGE	⊖	
TEMPERATURE INDICATOR CUM TRANSMITTER	⊖	
FLOW INDICATOR	⊖	
FLOW INDICATOR CUM TRANSMITTER	⊖	
PRESSURE REDUCING VALVE	⊖	
LEVEL INDICATOR CUM TRANSMITTER	⊖	
LEVEL GAUGE	⊖	
STRAINER	⊞	
OZONE CONCENTRATION INDICATOR	⊖	
RESIDUAL OZONE ANALYSER	⊖	

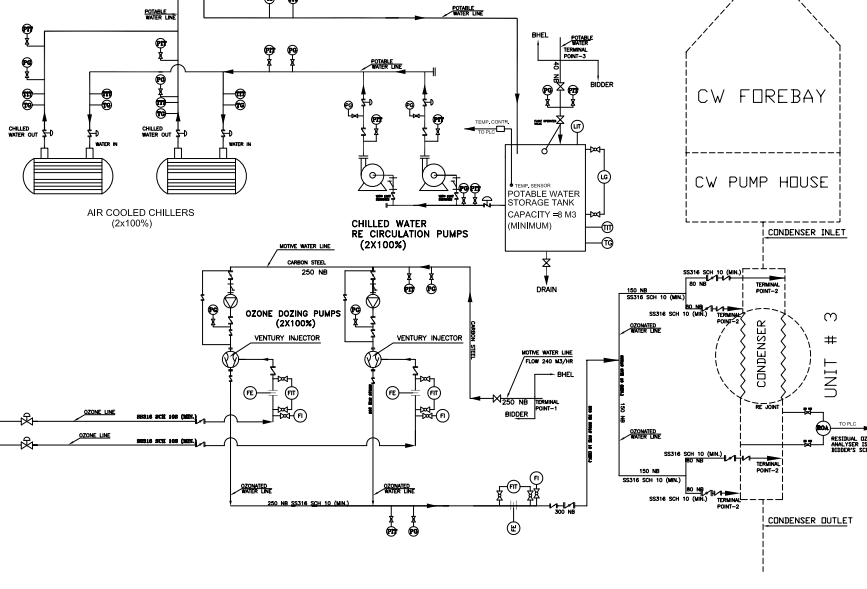
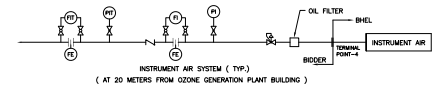
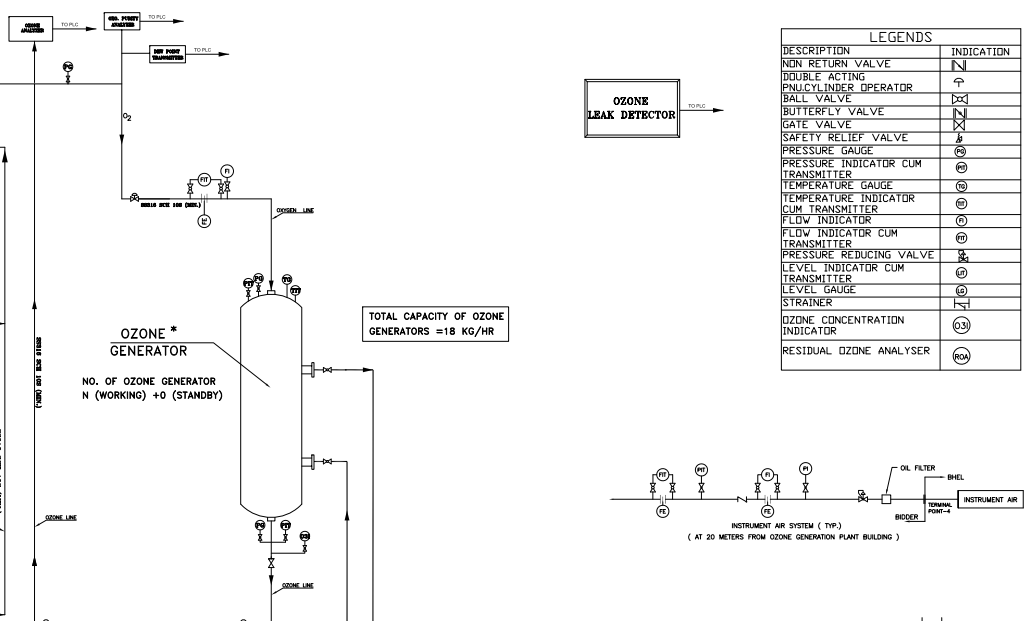
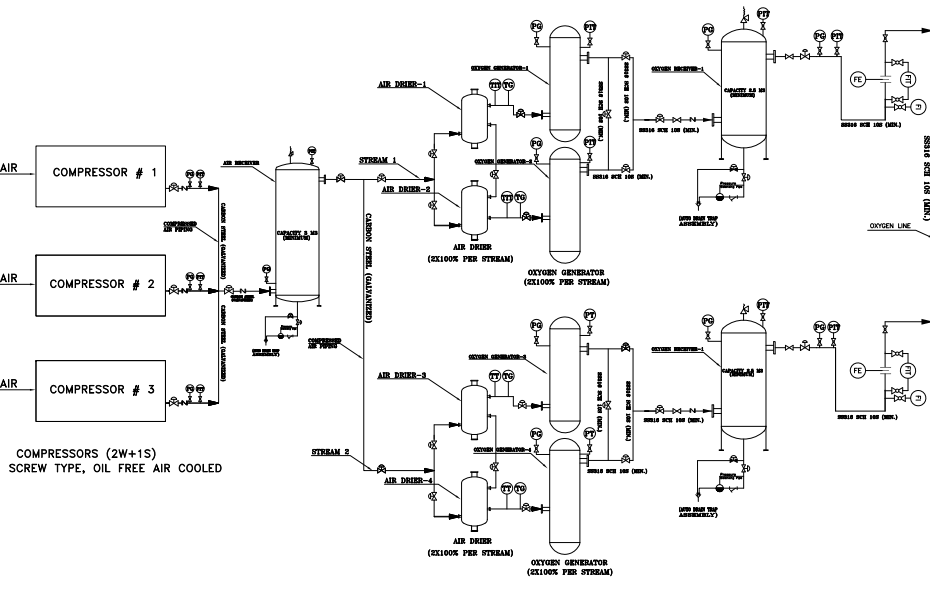

**PIPE SIZES OF CARBON STEEL PIPES**

NB	OD	THICK.	NB	OD	THICK.	NB	OD	THICK.
200	219.1	7.0	500	508.0	8.0	1200	1219	12.0
250	273.0	7.0	600	610.0	8.0	1600	1626	16.0
300	323.9	7.0	700	711.0	10.0	2000	1990	20.0
350	355.6	8.0	800	813.0	10.0			
400	406.4	8.0	900	914.0	10.0			
450	457.0	8.0	1100	1118	12.0			

- NOTES:**
- \* THE NUMBERS AND CAPACITY OF EACH OZONE GENERATOR WILL BE BASED ON SUPPLIER RECOMMENDATION.
  - ALL THE CONTROL MEASUREMENT, ANALYSERS & INTERLOCK SHALL HAVE REDUNDANT SENSORS, PLC SHALL BE PLACED IN AC ROOM, UPS SUPPLY TO BE USED FOR PLC.
  - ALL THE VALVES COMING IN SEQUENCE SHALL BE AUTOMATIC VALVES.
  - SOFT SIGNAL INTERFACE TO MAIN CONTROL ROOM CCR FOR MONITORING.
  - ALL THE ISOLATION VALVES OF ALL THE INSTRUMENTS SHALL BE OF SS316.
  - ALL THE SIGNALS USED IN CONTROL & INTERLOCKS, TRIPS SHALL BE REDUNDANT SIGNALS/MEASUREMENT.
  - BLANK FLANGES, COUNTER FLANGES & ISOLATION VALVES SHALL BE PROVIDED BY THE BIDDER AT THE TERMINAL POINTS.
  - ALL THE EQUIPMENTS, VALVES, INSTRUMENTS, PIPING ETC SHOWN IN THE P & ID IS IN BIDDER'S SCOPE UNLESS EXPLICITLY MENTIONED.
  - 2-VALVE MANIFOLD FOR PRESSURE MEASURING INSTRUMENTS/3-VALVE MANIFOLD FOR DP MEASURING INSTRUMENTS/ 5-VALVE MANIFOLD FOR OPTS, BALL VALVE FOR FLOW INDICATORS/ANALYTICAL INSTRUMENT SHALL BE PROVIDED.
  - ALL THE VALVES, INSTRUMENTS, EQUIPMENTS ETC. SHOWN IN THE P&ID ARE BARE MINIMUM, HOWEVER ANY ADDITIONAL VALVES, INSTRUMENTS, EQUIPMENTS ETC., AS REQUIRED BY BHEL/CUSTOMER DURING DETAILED ENGINEERING/EXECUTION E&C STAGE SHALL BE PROVIDED BY THE BIDDER WITHOUT ANY DELIVERY AND COMMERCIAL IMPLICATION TO BHEL/CUSTOMER.

JOB NO. : 367  
STATUS : CONTRACT  
DISTRIBUTION :  
TO :  
BY :  
DATE :

**1X700 MW BELLARY THERMAL POWER STATION UNIT NO. 3, STAGE-3**  
**KARNATAKA POWER CORPORATION LIMITED**

DESIGNED BY : BHARAT HEAVY ELECTRICALS LTD  
POWER SECTOR  
PROJECT : ENGINEERING MANAGEMENT  
NEW DELHI  
DATE :

**P&ID OF OZONE GENERATION PLANT**

REV	DATE	BY	CHKD	APPRO	REASON

DEPT. SCALE NTS  
DRAWING NO. PE-DG-367-174-14000A-A001  
SHEET 01 OF 01 REV. 01  
FORM NO. P&ID



**TITLE:**

**TECHNICAL SPECIFICATION FOR  
OZONE GENERATION PLANT**

**1X700 MW BELLARY THERMAL POWER  
STATION UNIT NO. 3, STAGE-3**

BHEL DOCUMENTS NO.: PE-TS-367-174-14000A-A001

VOL- IIB

SECTION-C1

REV. NO. 01

DATE: 24/02/2014

**DATASHEET -A  
ANNEXURE - VIII**



**TITLE:**  
**TECHNICAL SPECIFICATION FOR  
 OZONE GENERATION PLANT**  
**1X700 MW BELLARY THERMAL POWER  
 STATION UNIT NO. 3, STAGE-3**

BHEL DOCUMENTS NO.: PE-TS-367-174-14000A-A001  
 VOL- IIB  
 SECTION-C1  
 REV. NO. 01      DATE: 24/02/2014

**DATA SHEET-A**

SL NO.	DESCRIPTION	PARAMETERS
<b>1.0</b>	<b>OXYGEN GENERATION PLANT</b>	
<b>1.1</b>	<b>COMPRESSORS</b>	
1.1.1	No. of Compressors	3 Nos (2 Working +1 Standby)
1.1.2	Type	Multi stage , Screw type air cooled, oil free compressors
1.1.3	Capacity & Head	As per system requirements
1.1.4	Material of construction	
1.1.4.1	Casing	Cast Iron
1.1.4.2	Rotors	Carbon steel
1.1.5	Medium to be handled	Air
1.1.6	Suction temperature	Ambient
1.1.7	Accessories	Intake air filters, drive motor, intake silencer, step up gear box, moisture separator, ducting etc.
1.1.8	Dive motor	Electric drive motor
<b>1.2</b>	<b>AIR RECEIVER</b>	
1.2.1	Numbers	1 No.
1.2.2	Capacity	3.0 M <sup>3</sup> (minimum) or as per system requirement whichever is higher
1.2.3	Material of construction	Carbon Steel to IS 2062/IS 2002
1.2.4	Design Code for vessel	IS 2825/ASME Sec VIII Div. 1 or equivalent
1.2.5	Type	Vertical self-supporting cylindrical vessel
<b>1.3</b>	<b>AIR DRYERS</b>	
1.3.1	Numbers	2 Nos (2 x 100%) per stream. Total 4 nos for both the streams.
1.3.2	Capacity	As per system requirements
1.3.3	Material of construction	Carbon Steel to IS 2062/IS 2002
1.3.4	Design Code for vessel	IS 2825/ASME Sec VIII Div. 1 or equivalent
1.3.5	Desiccant	
1.3.5.1	Type	Activated alumina or equivalent material
<b>1.4</b>	<b>OXYGEN GENERATORS</b>	
1.4.1	Numbers	2 Nos (2 x 100%) per stream. Total 4 nos for both the streams.
1.4.2	Capacity	As per system requirements
1.4.3	Material of construction	Carbon Steel to IS 2062/IS 2002
1.4.4	Design Code for vessel	IS 2825/ASME Sec VIII Div. 1 or equivalent
<b>1.5</b>	<b>OXYGEN RECEIVER</b>	
1.5.1	Numbers	2 Nos (2 x 50%)
1.5.2	Capacity	2.5 M3 each (minimum) or as per system requirement whichever is higher
1.5.3	Material of construction	Carbon Steel to or IS 2062/IS 2002
1.5.4	Design Code	IS 2825/ASME Sec VIII Div. 1 or equivalent
1.5.5	Type	Vertical self-supporting cylindrical vessel
<b>2.0</b>	<b>OZONE GENERATION PLANT</b>	Total Capacity 18 Kg/hr
<b>2.1</b>	<b>OZONE GENERATORS</b>	
2.1.1	Numbers	N (Working)+0(Standby)*
2.1.2	Capacity	Supplier Specific*
2.1.3	Type	Vertical/Horizontal tubular
2.1.4	Material of construction	SS316L or better
2.1.4.1	Material of Tube	SS316L or better
2.1.4.2	Material of construction of Electrode	SS316L or better
<b>2.2</b>	<b>DI ELECTRIC GLASS TUBE</b>	
2.2.1	Type	Cylindrical
2.2.2	Material of construction	Borosilicate glass tube/ equivalent based on supplier recommendations
2.2.3	Construction	Close at one end or based on supplier recommendations
<b>3.0</b>	<b>OZONE DOSING PUMPS</b>	



**TITLE:**  
**TECHNICAL SPECIFICATION FOR  
 OZONE GENERATION PLANT**  
**1X700 MW BELLARY THERMAL POWER  
 STATION UNIT NO. 3, STAGE-3**

BHEL DOCUMENTS NO.: PE-TS-367-174-14000A-A001  
 VOL- IIB  
 SECTION-C1  
 REV. NO. 01      DATE: 24/02/2014

3.1	Number	2 Nos (2 x 100%)
3.2	Location	Indoor.
3.3	Fluid to be handled	Ozone with water
3.4	Service	To dose ozonised water in the inlet & outlet of condenser.
3.5	Type of Pump	Horizontal Centrifugal
3.6	Rated Capacity	As per supplier recommendations
3.7	Head to be developed	As per system requirements
3.8	Operation	Continuous
3.8	<b>Material of construction</b>	
	• Casing	CI to IS 210 Gr. FG 260
	• Impeller	SS316
	• Shaft	SS 410
	• Shaft sleeve material	SS 410
3.9	Pressure gauge	One for each pump with teflon diaphragm seal.
3.10	Accessories required for each pump	Coupling guard, drain plug, vent valve, suction hoses, isolation valves, Y- type strainers (SS316), pressure gauges, pulsation dampener.
3.11	Dive motor	Electric drive motor
<b>4.0</b>	<b>COOLING WATER PLANT</b>	
<b>4.1</b>	<b>CHILLED WATER RECIRCULATION PUMPS</b>	
4.1.1	Number	2 Nos (2 x 100%)
4.1.2	Location	Indoor
4.1.3	Fluid to be handled	Potable water
4.1.4	Type of Pump	Horizontal Centrifugal
4.1.5	Rated Capacity	As per supplier recommendations
4.1.6	Operation	Continuous
4.1.7	<b>Material of construction</b>	
	• Casing	SS316
	• Impeller	SS316
	• Shaft	SS 410
	• shaft sleeve material	SS 410
4.1.8	Pressure gauge	One for each pump with teflon diaphragm seal.
4.1.9	Accessories required for each pump	Coupling guard, drain plug, vent valve, suction hoses, isolation valves, Y- type strainers (SS316), pressure gauges, pulsation dampener.
4.1.10	Dive motor	Electric drive motor
<b>4.2</b>	<b>CHILLER</b>	
4.2.1	Numbers	2 Nos (2 x 100%)
4.2.2	Type	Air cooled
4.2.3	Capacity	As per system requirements based on supplier recommendations
4.2.4	Material of Construction	Caron Steel
<b>4.3</b>	<b>POTABLE WATER STORAGE TANK</b>	
4.3.1	Numbers	One number



**TITLE:**  
**TECHNICAL SPECIFICATION FOR  
 OZONE GENERATION PLANT**  
**1X700 MW BELLARY THERMAL POWER  
 STATION UNIT NO. 3, STAGE-3**

BHEL DOCUMENTS NO.: PE-TS-367-174-14000A-A001  
 VOL- IIB  
 SECTION-C1  
 REV. NO. 01      DATE: 24/02/2014

4.3.2	Capacity	8 M3 (minimum).
4.3.3	Material of construction	Carbon Steel Rubber Lined (Rubber lined shall be 4.5 mm thick in three layers)
4.3.4	Thickness	6 mm (minimum).
4.3.5	Type	Vertical cylindrical with dished bottom.
4.3.6	Accessories	Manhole, vent, drain, sample connection, level transmitter, operating platform, ladders , lifting lugs (4 nos minimum) etc.
<b>5.0</b>	<b>PIPING , FITTINGS &amp; FLANGES</b>	
5.1	Material of construction of piping, fittings and flanges handling Compressed air and instrument air.	Piping shall conform to Carbon steel to IS 1239 heavy grade /IS 3589 grade 410 galvanized to IS-4736. For pipe size > 150 NB the thickness shall be as indicated in the P&ID. The material of fittings and flanges shall be either same as the parent material or malleable iron to IS-1879 (galvanised).
5.2	Material of construction of piping, fittings and flanges handling Oxygen and Ozone gas	Piping shall be of Stainless steel to ASTM A 312 TP 316 sch. 10S (minimum) seamless. The material of fittings and flanges shall be of SS316 class 150 (minimum).
5.3	Material of construction of piping, fittings and flanges handling Ozonated water	Piping shall be of Stainless steel to ASTM A 312 TP 316 sch. 10 (minimum). The material of fittings and flanges shall be of SS316 class 150 (minimum).
5.4	Material of construction of piping, fittings and flanges handling Motive water. Design pressure of Motive water line shall be 7.5 kg/cm <sup>2</sup> (g) and design mechanical temperature shall be 50°C.	<ul style="list-style-type: none"> <li>• Piping upto and including 50 NB shall be of SS conforming to ASTM-A-312 Gr. 316 SCH 40S. The material of fittings and flanges shall be of SS316 class 150 (minimum).</li> <li>• Piping from 65 NB to 150 NB (including) shall be of SS conforming to ASTM-A-312 Gr. 316 SCH 10S. The material of fittings and flanges shall be of SS316 class 150 (minimum).</li> <li>• Piping 200 NB and above shall be of Carbon steel rolled and welded as per IS:3589 from CS plates as per IS:2062 with PU (Polyurethane) coating internally with minimum 2mm DFT as per AWWA-C-222. The material of fittings and flanges shall be of Carbon steel class 150 (minimum). The thickness of the piping shall be as indicated in P&amp;ID.</li> </ul>
5.5	Material of construction of piping, fittings and flanges handling Potable water. Design pressure of portable water line shall be 10 kg/cm <sup>2</sup> (g) and design mechanical temperature shall be 60°C.	Piping less than or equal to 150 NB shall be of carbon steel, ERW conforming to IS: 1239 (Heavy grade) and shall be galvanized as per IS 4736 or Equivalent. Pipe end connections shall be screwed. The material of fittings and flanges shall be of Carbon steel class 150 (minimum).



**TITLE:**  
**TECHNICAL SPECIFICATION FOR  
 OZONE GENERATION PLANT**  
**1X700 MW BELLARY THERMAL POWER  
 STATION UNIT NO. 3, STAGE-3**

BHEL DOCUMENTS NO.: PE-TS-367-174-14000A-A001  
 VOL- IIB  
 SECTION-C1  
 REV. NO. 01      DATE: 24/02/2014

VALVES							
6.1	Valves handling Compressed Air Services & Instrument air: Type of valves shall be inline with the P&ID. The material of all the safety relief valves shall be SS316.	For compressed air, instrument air application, valve material shall be galvanized cast carbon steel as mentioned below:					
		SIZE	BODY BONNET	DISC/GATE	STEM	HAND WHEEL	VALVE ENDS
		≥ 65 NB	ASTM A 216 Gr. WCB	ASTM A 216 Gr WCB	ASTM A479 Type 410-2	ASTM A47 Gr. 32510	FLANGED RAISED FACE
	≤50 NB	ASTM A 105	13% Cr Steel	ASTM A479 Type 410-2	ASTM A47 Gr. 32510	SCREWED TYPE	
6.2	Valves handling Oxygen, Ozone, Ozonated water: Type of valves shall be inline with the P&ID. The material of all the safety relief valves shall be SS316.	<b>GATE AND CHECK VALVES</b>					
		Body & Bonnet	SS316				
		Seating surface	SS 316				
		Stem & Disc/Gate	SS 316				
		Hinge pin	SS 316				
		<b>BUTTERFLY VALVES</b>					
		Body & Disc/flange	SS316				
		Shaft	SS316				
		<b>BALL VALVES (Full bore type)</b>					
		Body & Bonnet	SS316				
		Seating surface	SS316				
		Stem & ball	SS316				
		Hinge pin	SS316				
6.3	Valves handling Motive water, Potable water: The Type of valves shall be inline with the P&ID. The material of all the safety relief valves shall be SS316.	SIZE	BODY BONNET	DISC/GATE	STEM	HAND WHEEL	VALVE ENDS
		≥ 65 NB	ASTM A 216 Gr. WCB	ASTM A 216 Gr. WCB	ASTM A479TYPE 410-2	ASTM A47 Gr. 32510	FLANGED RAISED FACE
		≤50 NB	ASTM B62	ASTM B62	ASTM B312 GR. A	ASTM A47 Gr. 32510	SCREWED TYPE



**TITLE:**

**TECHNICAL SPECIFICATION FOR  
OZONE GENERATION PLANT**

**1X700 MW BELLARY THERMAL POWER  
STATION UNIT NO. 3, STAGE-3**

BHEL DOCUMENTS NO.: PE-TS-367-174-14000A-A001

VOL- IIB

SECTION-C1

REV. NO. 01

DATE: 24/02/2014

**QUALITY ASSURANCE PLAN  
ANNEXURE- IX**



TECHNICAL SPECIFICATION FOR OZONE GENERATION PLANT  
1X700 MW BELLARY THERMAL POWER STATION UNIT NO. 3, STAGE-3  
BHEL DOCUMENTS NO.: PE-TS-367-174-14000A-A001  
VOL-IIB, SECTION - C1.

**QUALITY ASSURANCE PLAN FOR PRESSURE VESSELS**

Sl.No.	Component & Operation	Characteristics	Class of check	Type of check	Quantum / Frequency of Check	Reference Document	Acceptance Standard	Format of Record	Scope of Check			Remarks
									BIDDER	BHEL	CUSTOMER	
<b>I ) Initial Procedure Qualifications :</b>												
a	Welding Procedure Qualification Tests	Procedure Qualification	Major	Visual & Mech Checks on Test Piece	100%	ASME SEC IX	ASME SEC IX	WPS - QW 482 & PQR - QW 483	P	V	V	<b>Note 1</b>
b	Welder Performance Qualification Tests	Performance Qualification	Major	Visual & Mech Checks on Test Piece	100%	ASME SEC IX	ASME SEC IX	WPQ - QW 484	P	V	V	<b>Note 1</b>
<b>II ) Raw Material Inspection :</b>												
a	Raw Material Identification for Shell, D/Ends, Pipes & Flanges	Verification of MTC & Chemical, Mechanical Properties	Major	Chemical & Mechanical Check	1 Per Heat / Lot	App.Drg. / Relevant code	ASME SEC II Part A for D/ends & IS 2062 for Shell	Mfr TC / Check Test Report	P	V	V	<b>Note 2 &amp; 3</b>
b	Surface Defects	Verification of Surface	Major	Visual	100%	No Pitting / Corrosion	No Pitting & Corrosion	SIR	P	V	V	
<b>III ) Inspection of Dished Ends :</b>												
a	Dimension & Visual Check	Dimensional Conformance, Thinning after forming & Visual	Major	Measurement & Visual	100%	App.Drg.	ASME SEC VIII / IS 4049	SIR	P	V	V	Thickness Check by De meter
b	DP Check on KR, SF & Edge	NDT	Major	Visual	100%	ASME SEC V	ASME SEC VIII Appendix 8	DP Report	P	V	V	
c	RT on D/end cordial seam	RT	Major	Visual	100%	ASME SEC V	ASME SEC VIII DIV I	RT Report	V	V	V	Review of RT Films by BHEL & CUSTOMER.
<b>IV ) In Process Inspection :</b>												
a	Shell Fabrication	Marking, Edge Preparation, rolling & Fit up	Major	Dimensional Conformance & Root Gap	100%	App.Drg.	App.Drg.	SIR	P	V	V	
b	Joint Preparation, Weld set-ups & Nozzles fittings	Alignment & Dimensions	Major	Measurement & Visual	100%	App.Drg.	App.Drg.	SIR	P	V	V	
c	Welding of shells, shell to D/ends & nozzles	Weld Parameter	Major	Visual	100%	AWPS & ASME SEC IX	AWPS & ASME SEC IX	Log Book	P	V	V	
d	DP Check on Butt Joints & Fillet Joints	NDT	Major	Visual	100% on Butt Joints & 10% on Fillet Joints	ASME SEC V	ASME SEC VIII Appendix 8	DP Report	P	V	V	
e	RT on T Joints & Butt Joints	RT	Major	Visual	As per Spec. / Drg	ASME SEC V	ASME SEC VIII ADIV I	RT Report	V	V	V	Review of RT Films by BHEL & CUSTOMER.
f	Air Leak Test (Soap Bubble Test) for Nozzle RF Pads	Weld Soundness	Major	Visual	100%	App.Drg. / Relevant code	No Leakage / Bubbles	FIR	W	V	V	Bubble Test @ 1.05 kg/cm <sup>2</sup> (g)

Contd...2



TECHNICAL SPECIFICATION FOR OZONE GENERATION PLANT  
 1X700 MW BELLARY THERMAL POWER STATION UNIT NO. 3, STAGE-3  
 BHEL DOCUMENTS NO.: PE-TS-367-174-14000A-A001  
 VOL-IIB, SECTION - C1,

**QUALITY ASSURANCE PLAN FOR PRESSURE VESSELS**

Sl.No.	Component & Operation	Characteristics	Class of check	Type of check	Quantum / Frequency of Check	Ref.Document	Acceptance Standard	Format of Record				Remarks
									Bidder	BHEL	CUSTOMER	
<b>V ) Stage Inspection</b>												
a	Dimension Check	Dimensional	Major	Measurement	100%	App.Drg.	App.Drg.	FIR	P	W	V	
b	Visual Check	Visual	Major	Visual Inspection	100%	App.Drg.	App.Drg.	FIR	P	W	V	
c	Hydro Static Pressure Test / Water Fill Test (As Applicable)	With stand of Hydro Test / Water Fill Test	Critical	Visual Inspection	100%	App.Drg.	No Leakage or Seepage	FIR	P	W	W	
d	Painting	DFT	Major	Visual Inspection	100%	App.Drg.	App.Drg.	FIR	P	V	V	
e	Stamping / Stenciling	To identify the Equipment	Major	Visual Inspection	100%	App.Drg.	App.Drg.	FIR	P	V	V	
f	Review of Testing and Measuring Instruments	To ensure the accuracy	Minor	Verification	100%	Calibration Certificate	National & International	TC	V	V	V	

NOTE 1: Only qualified welders & WPS to be used. In case welders are already qualified by customer / BHEL / LRIS / BVQI / DNV & doing similar jobs re-qualification is not required.

NOTE 2: Check Test shall be carried out on plates where ever corelation of TC with material is not available. Sample shall be identified & test Certificates shall be Verified by BHEL & CUSTOMER.

NOTE 3: All plates of pressure vessels shall be ultrasonically tested as follows:

(a) For nominal thickness 20 mm and higher when used for fabrication of dished ends

(b) For nominal thickness 40 mm and higher when used for fabrication of shells

(c) For nominal thickness 50 mm and higher when used for blind flanges

All thicknesses, when used for body flanges

NOTE 4: All test reports / Inspection reports related to the tank shall be furnished for BHEL / CUSTOMER review.

NOTE 5: Hydro test duration shall be 1hr at 1.5 times of design pressure or 2 times of working pressure whichever is higher & No Leakage will be permitted.

NOTE 6: The above mentioned quality inspection requirement are bare minimum. However any other test of any item as required by BHEL/Customer the same shall be provided by the bidder without and commercial and delivery implication to BHEL.

**ABBREVIATIONS:**

TC: Test Certificate  
 DFT: Dry Film Thickness  
 W: Witness

SIR: Stage Inspection Report  
 App.Drg. Approved Drawing  
 V: Verify Documents

FIR: Final Inspection Report  
 P: Perform



TECHNICAL SPECIFICATION FOR OZONE GENERATION PLANT  
1X700 MW BELLARY THERMAL POWER STATION UNIT NO. 3, STAGE-3  
BHEL DOCUMENTS NO.: PE-TS-367-174-14000A-A001  
VOL-IIB, SECTION - C1,

**QUALITY ASSURANCE PLAN FOR ATMOSPHERIC TANKS**

Sl.No.	Component & Operation	Characteristics	Class of check	Type of check	Quantum / Frequency of Check	Reference Document	Acceptance Standard	Format of Record	Scope of Check			Remarks
									BIDDER	BHEL	CUSTOMER	
<b>I ) Initial Procedure Qualifications :</b>												
a	Welding Procedure Qualification Tests	Procedure Qualification	Major	Visual & Mech Checks on Test Piece	100%	ASME SEC IX	ASME SEC IX	WPS - QW 482 & PQR - QW 483	P	V	V	<b>Note 1</b>
b	Welder Performance Qualification Tests	Performance Qualification	Major	Visual & Mech Checks on Test Piece	100%	ASME SEC IX	ASME SEC IX	WPQ - QW 484	P	V	V	<b>Note 1</b>
<b>II ) Raw Material Inspection :</b>												
a	Raw Material Identification for Shell, D/Ends, Pipes & Flanges	Verification of MTC & Chemical, Mechanical Properties	Major	Chemical & Mechanical Check	1 Per Heat / Lot	App.Drg. / Relevant code	ASME SEC II Part A for D/ends & IS 2062 for Shell	Mfr TC / Check Test Report	P	V	V	<b>Note 2 &amp; 3</b>
<b>III ) Inspection of Dished Ends :</b>												
a	Dimension & Visual Check	Dimensional Conformance, Thinning after forming & Visual	Major	Measurement & Visual	100%	App.Drg.	ASME SEC VIII / IS 4049	SIR	P	V	V	Thickness Check by De meter
b	DP Check on KR, SF & Edge	NDT	Major	Visual	100%	ASME SEC V	ASME SEC VIII Appendix 8	DP Report	P	V	V	
c	RT on D/end cordial seam	NDT	Major	Visual	As per Appd. Drg	ASME SEC V	ASME SEC VIII DIV I	RT Report	V	V	V	Review of RT Films by BHEL & CUSTOMER.
<b>IV ) In Process Inspection :</b>												
a	Shell Fabrication	Marking, Edge Preparation, rolling & Fit up	Major	Dimensional Conformance & Root Gap	100%	App.Drg.	App.Drg.	SIR	P	V	V	
b	Joint Preparation, Weld set-ups & Nozzles fittings	Alignment & Dimensions	Major	Measurement & Visual	100%	App.Drg.	App.Drg.	SIR	P	V	V	
c	Welding of shells, shell to D/ends & nozzles	Weld Parameter	Major	Visual	100%	AWPS & ASME SEC IX	AWPS & ASME SEC IX	Log Book	P	V	V	
d	DP Check on Butt Joints & Fillet Joints	NDT	Major	Visual	100% on Butt Joints & 10% on Fillet Joints	ASME SEC V	ASME SEC VIII Appendix 8	DP Report	P	V	V	
e	RT on T Joints & Butt Joints	NDT	Major	Visual	As per Spec. / Drg	ASME SEC V	ASME SEC VIII DIV I	RT Report	V	V	V	Review of RT Films by BHEL & CUSTOMER.
f	Air Leak Test (Soap Bubble Test) for Nozzle RF Pads	Weld Soundness	Major	Visual	100%	App.Drg. / Relevant code	No Leakage / Bubbles	FIR	W	V	V	Bubble Test @ 1.05 kg/cm2 (g)

Contd...2



TECHNICAL SPECIFICATION FOR WATER OZONE GENERATION PLANT  
1X700 MW BELLARY THERMAL POWER STATION UNIT NO. 3, STAGE-3  
BHEL DOCUMENTS NO.: PE-TS-367-174-14000A-A001  
VOL-IIB, SECTION - C1,

**QUALITY ASSURANCE PLAN FOR ATMOSPHERIC TANKS**

Sl.No.	Component & Operation	Characteristics	Class of check	Type of check	Quantum / Frequency of Check	Ref.Document	Acceptance Standard	Format of Record	Scope of Check			Remarks
									BIDDER	BHEL	CUSTOMER	
<b>V ) Stage Inspection before Rubber Lining :</b>												
a	Dimension Check	Dimensional	Major	Measurement	100%	App.Drg.	App.Drg.	FIR	P	W	V	
b	Visual Check	Visual	Major	Visual Inspection	100%	App.Drg.	App.Drg.	FIR	P	W	V	
c	Hydro Static Pressure Test / Water Fill Test (As Applicable)	With stand of Hydro Test / Water Fill Test	Critical	Visual Inspection	100%	App.Drg.	No Leakage or Seepage	FIR	P	W	W	
f	Painting	DFT	Major	Visual Inspection	100%	App.Drg.	App.Drg.	FIR	P	V	V	
g	Stamping / Stenciling	To identify the Equipment	Major	Visual Inspection	100%	App.Drg.	App.Drg.	FIR	P	V	V	
h	Review of Testing and Measuring Instruments	To ensure the accuracy	Minor	Verification	100%	Calibration Certificate	National & International Standards	TC	V	V	V	

NOTE 1: Only qualified welders & WPS to be used. In case welders are already qualified by customer / BHEL / LRIS / BVQI / DNV & doing similar jobs re-qualification is not required.

NOTE 2: Check Test shall be carried out on plates where ever correlation of TC with material is not available. Sample shall be identified & test Certificates shall be Verified by BHEL.

NOTE 3: All test reports / Inspection reports related to the tank shall be furnished for BHEL / CUSTOMER review.

NOTE 4: Hydro test duration shall be 1hr at 1.5 times of design pressure or 2 times of working pressure whichever is higher & No Leak shall be permitted.

NOTE 5: For Rubber Lining refer separate QAP. Rubber Lining shall be carried out after Hydro Test and clearance from BHEL.

NOTE 6: Hydro test will be conducted before Rubber Lining.

NOTE 7: The above mentioned quality inspection requirement are bare minimum. However any other test of any item as required by BHEL/Customer the same shall be provided by the bidder without and commercial and delivery implication to BHEL.

**ABBREVIATIONS:**

TC: Test Certificate  
DFT: Dry Film Thickness  
W: Witness

SIR: Stage Inspection Report  
App.Drg. Approved Drawing  
V : Verify Documents

FIR: Final Inspection Report  
P: Perform



TECHNICAL SPECIFICATION FOR OZONE GENERATION PLANT  
1X700 MW BELLARY THERMAL POWER STATION UNIT NO. 3, STAGE-3  
BHEL DOCUMENTS NO.: PE-TS-367-174-14000A-A001  
VOL-IIB, SECTION - C1,

**QUALITY ASSURANCE PLAN FOR RUBBER LINING**

Sl.No.	Component & Operation	Characteristics	Class of check	Type of check	Quantum / Frequency of	Reference Document	Acceptance Standard	Format of Record	Scope of Check			Remarks
									BIDDER	BHEL	CUSTOMER	
<b>I ) RUBBER SHEET :</b>												
a	Rubber Sheet Inspection	Surface and Thickness check	Major	Visual & Measurement	100%	App.Drg.	App.Drg	SIR	P	V	V	
b	Tensile Strength & % Elongation	Strength	Major	Mechanical Test	1 Sample per Batch	IS 3400 Part 1	TS > 120 kg/cm2 & Elongation > 350%	TC	P	V	V	
c	Resistance to Bleeding Test	Resistivity	Major	Chemical Test	1 Sample per Batch	IS 3400 Part 1	No Discoloration & Weight gain limit -0% to +2%	TC	P	V	V	<b>Note 1</b>
<b>II ) IN PROCESS INSPECTION</b>												
a	Surface Preparation	Blast Clean Surface free from foreign mats.	Major	Visual Inspection	100%	App.Drg. / IS4682	App.Drg / IS4682	SIR	P	V	V	
b	Adhesive Coat I	--	Major	Visual Inspection	100%	App.Drg. / IS4682	App.Drg / IS4682	SIR	P	V	V	
c	Adhesive Coat II	--	Major	Visual Inspection	100%	App.Drg. / IS4682	App.Drg / IS4682	SIR	P	V	V	
d	Continuity of Lining	Spark Test	Major	Visual Inspection	100%	App.Drg. / IS4682	No spark at 5KV / mm of lining thk	FIR	P	V	V	
e	Curing of Rubber Lining	Control of Pressure / Temperature / Time of Steam / Water	Major	Measurement & visual	100%	IS4682	IS4682 Part 1	Log book	P	V	V	
<b>III ) FINAL INSPECTION FOR LINED VESSELS</b>												
a	Visual Check	Visual	Major	Visual Inspection	100%	App.Drg.	App.Drg / IS4682	FIR	P	V	W	
b	Adhesion Test	Adhesion Strength*	Critical	Measurement & visual	100%	App.Drg. / IS4682	IS 4682 Part 1	FIR	P	V	W	*1 test piece per lot
c	Thickness Verification	Thickness	Major	Measurement	Random	App.Drg.	Thk Tolerance = -10% to +15%	FIR	P	V	W	
d	Hardness Check	Hardness Shore A	Major	Visual Inspection	100%	App.Drg. / IS4682	App.Drg	FIR	P	V	W	
e	Continuity of Lining	Spark Test	Major	Visual Inspection	100%	App.Drg. / IS4682	No spark at 5KV / mm of lining thk	FIR	P	V	W	
f	Review of Testing and Measuring	To ensure the accuracy	Minor	Verification	100%	Calibration Certificate	National & Intl. Standards	TC	V	V	W	

**NOTE 1:** Sample to be kept in 33% HCl, 48% NaOH & DM Water for 72Hrs at 50 Deg C and shall pass as per Acceptance standard.

**NOTE 2:** The above mentioned quality inspection requirement are bare minimum. However any other test of any item as required by BHEL/Customer the same shall be provided by the bidder without and commercial and delivery implication to BHEL.

**ABBREVIATIONS:**

TC: Test Certificate  
DFT: Dry Film Thickness  
W: Witness

SIR: Stage Inspection Report  
App.Drg. Approved Drawing  
V: Verify Documents

FIR: Final Inspection Report  
RW: Random Witness

P: Perform  
R: Review



TECHNICAL SPECIFICATION FOR COOLING WATER OZONE GENERATION PLANT  
1X700 MW BELLARY THERMAL POWER STATION UNIT NO. 3, STAGE-3  
BHEL DOCUMENTS NO.: PE-TS-367-174-14000A-A001  
VOL-IB, SECTION - C1,

**QUALITY ASSURANCE PLAN FOR CENTRIFUGAL PUMPS**

SI.No.	Component & Operation	Characteristics	Class of check	Type of check	Quantum / Frequency of Check	Ref.Document	Acceptance Standard	Format of Record	Scope of Check			Remarks
									BIDDER	BHEL	CUSTOMER	
<b>I) Raw Material Inspection :</b>												
a	Raw Material Identification for Casing, Impeller, Shaft, Casing Wearing ring & Shaft sleeve.	Chemical Analysis & Mechanical Tests	Major	Chemical Analysis & Mechanical Tests	1 Per Heat / Lot	App.Drg. / Relevant code	App.Drg. / Relevant code	Mfr TC / IR	P	V	V	<b>Note 1 &amp; 3</b>
b	Check for Surface defects and Dimensional conformity of the Raw materials.	Dimensional & Visual	Major	Visual & Measurement	100%	App.Drg. / Relevant code	App.Drg. / Relevant code	Mfr TC / IR	P	V	V	
c	Motors	Speed, Power, IP, Mounting Type	Major	Visual	100%	As Per IS 325	Relevant code	Routine Test Report	R	V	V	
<b>II) In Process Inspection :</b>												
a	Machining of Casings, Impeller	Dimensions & Alignment	Major	Visual & Measurement	100%	Appd. Drg & Data Sheet	Appd. Drg	SIR	P	V	V	
b	DP Check on Machined Surface	NDT	Major	Visual	100%	ASME SEC V	ASME SEC VIII & Appendix 8	SIR	P	V	V	
c	Hydro test for casings	With stand of Hydro Static	Critical	Hydro	100%	Appd. Drg & Data Sheet / IS 5120	Appd. Drg & Data Sheet / IS 5120 & No Leakage	SIR	P	W	V	
d	Dynamic Balancing of Impeller	Dynamic / Static Balancing	Critical	Visual & Measurement	100%	ISO 1940 Gr.6.3	Relevant code	SIR	P	V	V	
e	Assembly of Pump	Alignment, Fitment	Major	Visual & Measurement	100%	Appd. Drg & Data Sheet	Appd. Drg	--	P	V	V	
<b>III) Final Inspection :</b>												
a	Dimension Check	Dimensions	Major	Measurement	100%	Appd. Drg & Data Sheet	Appd. Drg	FIR	P	W	V	<b>NOTE 5</b>
b	Performance Test (With Job Motor)	Capacity vs Head, Capacity vs Power and Capacity vs Efficiency	Major	Measurement	100%	Appd. Drg & Data Sheet / HIS	Appd. Drg & Data Sheet / HIS	PTR	P	W	W	
		Temperature raise in Oil & Bearing Hsg.	Critical	Measurement	100%	Appd. Drg & Data Sheet	Appd. Drg & Data Sheet		P	W	W	
		Vibration & Noise Level	Major	Measurement	100%	Appd. Drg & Data Sheet	Appd. Drg & Data Sheet		P	W	W	
c	Strip Down Test	Wear & Tear	Major	Visual / Strip test	100%	IS 5120	As per IS 5120	FIR	P	W	V	
d	Rotor Run out Test	Alignment	Major	Visual & Measurement	100%	IS 5120	As per IS 5120	FIR	P	W	V	

Contd...2



TECHNICAL SPECIFICATION FOR OZONE GENERATION PLANT  
 1X700 MW BELLARY THERMAL POWER STATION UNIT NO. 3, STAGE-3  
 BHEL DOCUMENTS NO.: PE-TS-367-174-14000A-A001  
 VOL-IIB, SECTION - C1,

**QUALITY ASSURANCE PLAN FOR CENTRIFUGAL PUMPS**

Sl.No.	Component & Operation	Characteristics	Class of check	Type of check	Quantum / Frequency of Check	Ref.Document	Acceptance Standard	Format of Record	Scope of Check			Remarks
									BIDDER	BHEL	CUSTOMER	
<b>IV ) Painting :</b>												
a	Surface Preparation	Roughness / Free from foreign matls.	Major	Visual	100%	Approved Drg. & Data Sheet	Approved Drg. & Data Sheet	SIR	P	V	V	
<b>V ) Stamping / Stenciling :</b>												
a	Identification	To identify the Equipment	Major	Visual	100%	Approved Drg. & Data Sheet	Approved Drg. & Data Sheet	SIR	P	V	V	
<b>VI ) Testing and Measuring Equipment :</b>												
a	Calibration status of equipments	To ensure the accuracy	Major	Verification	100%	National & Intl Standards	National & Intl Standards	Calibration Certificates	P	V	V	

NOTE 1: UT shall be carried out for plates thickness 20mm and above & Forgings 50mm dia and above.

NOTE 3: MTC shall be provided for metallic parts.

NOTE 4: Hydro Test on casings shall be carried out at 2 times of rated head or 1.5 times of shut off head which ever is higher and the test pressure shall be maintained for 30 minutes & No Leakage shall be permitted.

NOTE 5: The duration of performance test shall be minimum 1 hour.

NOTE 6: The above mentioned quality inspection requirement are bare minimum. However any other test of any item as required by BHEL/Customer the same shall be provided by the bidder without and commercial and delivery implication to BHEL.

**ABBREVIATIONS:**

TC: Test Certificate

PTR: Performance Test Report

W: Witness

SIR: Stage Inspection Report

Appd. Drg. Approved Drawing

V : Verify Documents

FIR:

RW: Random Witness

Mft's Std.

Final Inspection Report

Random Witness

Manufacturer's Standard

P: Perform

R: Review



**QUALITY ASSURANCE PLAN FOR CHECK VALVES**

Sl.No.	Component & Operation	Characteristics	Class of check	Type of check	Quantum / Frequency of Check	Ref.Document	Acceptance Standard	Format of Record	SCOPE OF CHECK			Remarks
									BIDDER	BHEL	CUSTOMER	
<b>I ) Raw Material Inspection :</b>												
a	Material identification for Body, Plate Castings	Material Properties	Major	Chemical & Mechanical	100%	Appd. drg., Appd. Data Sheet & Relevant Mtrl.specs	Appd. drg., Appd. Data Sheet & Relevant Mtrl.specs	FOUNDARY TC/COC	P	V	V	
			Major	Physical	100%	Appd. drg., Appd. Data Sheet & Relevant Mtrl.specs	Appd. drg., Appd. Data Sheet & Relevant Mtrl.specs	FOUNDARY TC/COC	P	V	V	
			Major	Dimension & Surface Check	100%	Appd. drg., Appd. Data Sheet & Relevant Mtrl.specs	Appd. drg., Appd. Data Sheet & Relevant Mtrl.specs	Inspection Reports	P	V	V	
b	Hinge/ Stop Pin	Material Properties	Major	Chemaical Analysis	1 sampel per Heat number	Appd. drg., Appd. Data Sheet & Relevant Mtrl.specs	Appd. drg., Appd. Data Sheet & Relevant Mtrl.specs	MTC/COC	P	V	V	
			Major	Visual Inspection	100%	Appd. drg., Appd. Data Sheet & Relevant Mtrl.specs	Appd. drg., Appd. Data Sheet & Relevant Mtrl.specs	Inspection Report	P	V	V	
c	Spring	Material Properties	Major	Chemaical Analysis	1 sampel per Heat number	Relevant Mtrl.specs	Relevant Mtrl.specs	MTC/COC	P	V	V	
<b>II ) In Process Inspection :</b>												
a	Body & Plate Machining	Dimensions	Major	Measurement	Sample	Manufacturing drng	Manufacturing drng	SIR	P	V	V	
		Finish	Major	Visual	100%	Manufacturing drng	Manufacturing drng	-	P	V	V	
		DPT	Major	Visual	100%	As per ASME Sec V.	As per ASME Sec V.	DPT Report	P	V	V	
b	Rubber Lining on body	Vulcanising Soundness	Major	Visual, Spark leak Test & Hardness	100%	As per Procudure for Rubber Linign	As per Procudure for Rubber Linign	Inspection Report	P	V	V	
<b>III ) Final Inspection :</b>												
a	Assembly of Valve	Dimensions & Overall Finishing	Major	Measurement	100%	Appd.Drg/Datas sheet.	Appd.Drg/Dtas sheet.	FIR	W	V	V	
b	Hydrostatic Test	Body Hydro Test	Major	Pr.Test Hydro	100%	Appd.Drg/Datas sheet/No Leakage. API 598	Appd.Drg/Datas sheet/No Leakage. API 598	FIR	W	W	W	
		Seat Hydro Test	Major	Pr.Test Hydro	100%	Appd.Drg/Datas sheet/No Leakage. API 598	Appd.Drg/Datas sheet/No Leakage. API 598	FIR	W	W	W	
c	Performance Test	Smooth Operation of Plates	Critical	Operational(open-close)	100%	Appd. Drg & Data Sheet, API 594 / API 598	Appd. Drg & Data Sheet, API 594 / API 598	FIR	W	W	W	
d	Surface Preparation	Painting	Major	Visual	100%	Appd.Drg/Data sheet.	Appd.Drg/Data sheet.	Test Certificate	W	V	V	
<b>IV) Documents Review &amp; Release Note</b>												
a	Document Review & Issue of Release note	Final document review	Critical	Document Review	100%	-	-	Inspection Reports,Test certificates,Issue of Release note	V	V	V	

NOTE 1: The above mentioned quality inspection requirement are bare minimum. However any other test of any item as required by BHEL/Customer the same shall be provided by the bidder without and commercial and delivery implication to BHEL.

**ABBREVIATIONS:**

TC: Test Certificate  
W: Witness

SIR: Stage Inspection Report  
Appd. Drg. Approved Drawing

FIR: Final Inspection Report  
V: Verify Documents

P: Perform  
COC: Certificate of Compliance



**TECHNICAL SPECIFICATION FOR OZONE GENERATION PLANT  
1X700 MW BELLARY THERMAL POWER STATION UNIT NO. 3, STAGE-3**

BHEL DOCUMENTS NO.: PE-TS-367-174-14000A-A001

VOL-IIIB, SECTION - C1,

**QUALITY ASSURANCE PLAN FOR BUTTERFLY VALVES (MANUAL / ACTUATED)**

Sl.No.	Component & Operation	Characteristics	Class of check	Type of check	Quantum / Frequency of Check	Ref.Document	Acceptance Standard	Format of Record	SCOPE OF CHECK			Remarks
									BIDDER	BHEL	CUSTOMER	
<b>I ) Raw Material Inspection :</b>												
a	Material identification for Body, Disc & Wetted Parts	Mechanical & chemical Property Check	Major	Verification with respect stds	100%	Appd. drg., Appd. Data Sheet & Relevant code	Appd. drg., Appd. Data Sheet & Relevant code	Mfr. TC or Check Test Report	P	V	V	<b>Note 1 &amp; 2</b>
b	Receiving Inspection of Bought outs	Visual Defects	Major	Verification with respect stds & Visual Check	100%	Appd. drg. & Relevant code	Appd. drg. & Relevant code	Receiving Inspection	P	V	V	
<b>II ) In Process Inspection :</b>												
a	Machining of Body, Disc ,Components & Actuators.	Dimensions & Alignment	Major	Visual & Measurement	100%	App.Drg.	App.Drg.	SIR	P	V	V	
b	DP Check on Machined Surface & Actuators	Surface Defects	Major	Visual	100%	ASME SEC V	ASME SEC VIII	DP Report	P	V	V	
<b>III B ) Assembly Check :</b>												
a	Assembly of Valves	Verification of all stages	Major	Verification with equipment drg	100%	Assy. Procedure, Equip. drg & Appd. Data Sheet	Assy. Procedure, Equip. drg & Appd. Data Sheet	--	P	V	V	
b	Assembly of Actuators	Verification of all stages	Major	Verification with Appd. Drg	100%	Assy. Procedure, Appd. drg & Appd. Data Sheet	Assy. Procedure, Appd. drg & Appd. Data Sheet	--	P	V	V	
<b>IV ) Final Inspection :</b>												
a	Dimension Check	Dimensions	Major	Measurement	100%	Appd. Drg & Data Sheet	Appd. Drg & Data Sheet	FIR	P	V	V	<b>Note 3</b>
b	Operational Check	Smooth Movement	Major	Visual	100%	Appd. Drg & Data Sheet	Appd. Drg & Data Sheet	FIR	P	W	W	
c	Pneumatic Test for Valve Seat	Leakage Proof	Major	Visual	100%	Appd. Drg & Data Sheet	Appd. Drg & Data Sheet	FIR	P	V	V	
d	Hydro Static Pressure Test on Seat & Body	With stand of Hydro Static & Leak Proof	Critical	Visual	100%	Appd. Drg & Data Sheet	Appd. Drg & Data Sheet	FIR	P	W	W	<b>Note 4</b>
e	Actuator performance (Job Actuator)	Leak tightness,Accuracy& simulation(Air to open/close)	Major	Visual	100%	Appd. Drg & Data Sheet	Appd. Drg & Data Sheet	FIR	P	W	W	
<b>V ) Painting :</b>												
a	Surface Preparation	Roughness / Free from foreign matls.	Major	Visual	100%	Appd. Drg & Data Sheet	Appd. Drg & Data Sheet	SIR	P	V	V	
<b>VI ) Stamping / Stenciling :</b>												
a	Identification	To identify the Equipment	Major	Visual	100%	Appd. Drg & Data Sheet	Appd. Drg & Data Sheet	SIR	P	V	V	
<b>VII ) Testing and Measuring Equipment :</b>												
a	Calibration status of equipments	To ensure the accuracy	Major	Verification	100%	National & Intl Standards	National & Intl Standards	Calibration Certificates	P	V	V	

**NOTE 1 :** UT shall be carried out for plates thickness 20mm and above & Forgings 50mm dia and above (Only for Metallic).

**NOTE 2:** MTC shall be provided for metallic parts.

**Note 3:** Hydrostatic test for seat and body-1.1 X Maximum working pressure for seat and 1.5 X Maximum working pressure for shell& No Leakage will be permitted.

**Note 4:** Seat Leakage Test should be done in both the directions

**Note 5:** Proof of Design and Disc strength as per AWWAC-504 requirements needs to be conducted.

**NOTE 6:** The above mentioned quality inspection requirement are bare minimum. However any other test of any item as required by BHEL/Customer the same shall be provided by the bidder without and commercial and delivery implication to B

**ABBREVIATIONS:**

TC: Test Certificate

W: Witness

SIR: Stage Inspection Report

Appd. Drg. Approved Drawing

FIR: Final Inspection Report

V : Verify Documents

P: Perform

UT: Ultrasonic Testing



**TECHNICAL SPECIFICATION FOR OZONE GENERATION PLANT**  
**1X700 MW BELLARY THERMAL POWER STATION UNIT NO. 3, STAGE-3**  
**BHEL DOCUMENTS NO.: PE-TS-367-174-14000A-A001**  
**VOL-IIB, SECTION - C1,**

**QUALITY ASSURANCE PLAN FOR BALL VALVES (MANUAL / ACTUATED)**

Sl.No.	Component & Operation	Characteristics	Class of check	Type of check	Quantum / Frequency of Check	Ref.Document	Acceptance Standard	Format of Record	SCOPE OF CHECK			Remarks
									BIDDER	BHEL	CUSTOMER	
<b>I ) Raw Material Inspection :</b>												
a	Material identification for Body,Ball,&stem.	Material Properties	Major	Chemical+Mechanical	100%	Appd. drg., Appd. Data Sheet & Relevant Mtrl.specs	Appd. drg., Appd. Data Sheet & Relevant Mtrl.specs	FOUNDARY TC/COC	P	V	V	
			Major	Physical	100%	Appd. drg., Appd. Data Sheet & Relevant Mtrl.specs	Appd. drg., Appd. Data Sheet & Relevant Mtrl.specs	FOUNDARY TC/COC	P	V	V	
<b>II ) In Process Inspection :</b>												
a	Body,Ball & Stem	Dimensions	Major	Measurement	Sample	Manufacturing drng	Manufacturing drng	SIR	P	V	V	
		Finish	Major	Visual	100%	Manufacturing drng	Manufacturing drng	-	P	V	V	
		UT for shaft (Dia>50 mm)	Critical	Visual & Measurement	100%	ASTM A388	BE>80 & DE<20%	Test Report	P	V	V	
<b>III ) Final Inspection :</b>												
a	Assembly of Valve	Dimensions	Major	Measurement	100%	Appd.Drg/Dtas sheet.	Appd.Drg/Dtas sheet.	FIR	W	V	V	
b	Operational Check	Smooth Movement	Major	Visual	100%	Appd. Drg & Data Sheet	Appd. Drg & Data Sheet	FIR	P	W	V	
c	Pneumatic Test for Valve Seat	Leakage Proof	Major	Visual	100%	Appd. Drg & Data Sheet	Appd. Drg & Data Sheet	FIR	P	W	V	
d	Hydro Static Pressure Test on Seat & Body	Body Hydro Test	Major	Pr.Test Hydro	100%	Appd.Drg/Dtas sheet/No Leakage.	Appd.Drg/Dtas sheet/No Leakage.	FIR	W	W	V	Note 1
		Seat Hydro Test	Major	Pr.Test Hydro	100%	Appd.Drg/Dtas sheet/No Leakage.	Appd.Drg/Dtas sheet/No Leakage.	FIR	W	W	V	Note 1
e	Actuator performance (Job Actuator)	Leak tightness,Accuracy& simulation(Air to	Major	Visual	100%	Appd. Drg & Data Sheet	Appd. Drg & Data Sheet	FIR	P	W	V	
f	Surface Preparation	Painting	Major	Visual	100%	Appd. Drg & Data Sheet	Appd. Drg & Data Sheet	Test Certificate	V	V	V	
III b	Document Review & Issue of Release note	Final document review	Critical	Document Review	100%	-	-	Inspection Reports,Test certificates,Issue of Release note	V	V	V	

**Note 1:** Hydrostatic test for seat and body-1.1 X Maximum working pressure for seat and 1.5 X Maximum working pressure for shell & No Leakage will be permitted.  
**NOTE 6:** The above mentioned quality inspection requirement are bare minimum. However any other test of any item as required by BHEL/Customer the same shall be provided by the bidder without and commercial and delivery implication to BHEL.

**ABBREVIATIONS:**

TC: Test Certificate  
W: Witness

SIR: Stage Inspection Report  
Appd. Drg. Approved Drawing

FIR: Final Inspection Report  
V: Verify Documents

P: Perform  
UT: Ultrasonic Testing



TECHNICAL SPECIFICATION FOR OZONE GENERATION PLANT  
1X700 MW BELLARY THERMAL POWER STATION UNIT NO. 3, STAGE-3  
BHEL DOCUMENTS NO.: PE-TS-367-174-14000A-A001  
VOL-IIB, SECTION - C1,

**QUALITY ASSURANCE PLAN FOR OZONE GENERATOR**

Sl.No.	Component & Operation	Characteristics	Class of check	Type of check	Quantum / Frequency of Check	Reference Document	Acceptance Standard	Format of Record	Scope of Check			Remarks
									BIDDER	BHEL	CUSTOMER	
<b>I ) Initial Procedure Qualifications :</b>												
a	Welding Procedure Qualification Tests	Procedure Qualification	Major	Visual & Mech Checks on Test Piece	100%	ASME SEC IX	ASME SEC IX	WPS - QW 482 & PQR - QW 483	P	V	V	<b>Note 1</b>
b	Welder Performance Qualification Tests	Performance Qualification	Major	Visual & Mech Checks on Test Piece	100%	ASME SEC IX	ASME SEC IX	WPQ - QW 484	P	V	V	<b>Note 1</b>
<b>II ) Raw Material Inspection :</b>												
a	Raw Material Identification for Shell, D/Ends, Pipes & Flanges	Verification of MTC & Chemical, Mechanical Properties	Major	Chemical & Mechanical Check	1 Per Heat / Lot	App.Drg. / Relevant code	ASME SEC II Part A for D/ends & IS 2062 for Shell	Mfr TC / Check Test Report	P	V	V	<b>Note 2 &amp; 3</b>
b	Surface Defects	Verification of Surface	Major	Visual	100%	No Pitting / Corrosion	No Pitting & Corrosion	SIR	P	V	V	
<b>III ) Inspection of Dished Ends :</b>												
a	Dimension & Visual Check	Dimensional Conformance, Thinning after forming & Visual	Major	Measurement & Visual	100%	App.Drg.	ASME SEC VIII / IS 4049	SIR	P	V	V	Thickness Check by De meter
b	DP Check on KR, SF & Edge	NDT	Major	Visual	100%	ASME SEC V	ASME SEC VIII Appendix 8	DP Report	P	V	V	
c	RT on D/end cordial seam	RT	Major	Visual	100%	ASME SEC V	ASME SEC VIII DIV I	RT Report	V	V	V	Review of RT Films by BHEL & CUSTOMER.
<b>IV ) In Process Inspection :</b>												
a	Shell Fabrication	Marking, Edge Preparation, rolling & Fit up	Major	Dimensional Conformance & Root Gap	100%	App.Drg.	App.Drg.	SIR	P	V	V	
b	Joint Preparation, Weld set-ups & Nozzles fittings	Alignment & Dimensions	Major	Measurement & Visual	100%	App.Drg.	App.Drg.	SIR	P	V	V	
c	Welding of shells, shell to D/ends & nozzles	Weld Parameter	Major	Visual	100%	AWPS & ASME SEC IX	AWPS & ASME SEC IX	Log Book	P	V	V	
d	DP Check on Butt Joints & Fillet Joints	NDT	Major	Visual	100% on Butt Joints & 10% on Fillet Joints	ASME SEC V	ASME SEC VIII Appendix 8	DP Report	P	V	V	
e	RT on T Joints & Butt Joints	RT	Major	Visual	As per Spec. / Drg	ASME SEC V	ASME SEC VIII ADIV I	RT Report	V	V	V	Review of RT Films by BHEL & CUSTOMER.
f	Pneumatic Test	Pressure Test	Major	Measurement	100%	App.Drg. / Relevant code	App.Drg. / Relevant code	Test Certificates, Inspection Reports	W	V	V	Bubble Test @ 1.05 kg/cm2 (g)

Contd...2



TECHNICAL SPECIFICATION FOR OZONE GENERATION PLANT  
1X700 MW BELLARY THERMAL POWER STATION UNIT NO. 3, STAGE-3  
BHEL DOCUMENTS NO.: PE-TS-367-174-14000A-A001  
VOL-IIB, SECTION - C1,

**QUALITY ASSURANCE PLAN FOR OZONE GENERATOR**

Sl.No.	Component & Operation	Characteristics	Class of check	Type of check	Quantum / Frequency of Check	Ref.Document	Acceptance Standard	Format of Record				Remarks
									Bidder	BHEL	CUSTOMER	
<b>V ) Stage Inspection</b>												
a	Dimension Check	Dimensional	Major	Measurement	100%	App.Drg.	App.Drg.	FIR	P	W	V	
b	Visual Check	Visual	Major	Visual Inspection	100%	App.Drg.	App.Drg.	FIR	P	W	V	
c	Hydro Static Pressure Test	With stand of Hydro Test	Critical	Visual Inspection	100%	App.Drg.	No Leakage or Seepage	FIR	P	W	W	
d	Stamping / Stenciling	To identify the Equipment	Major	Visual Inspection	100%	App.Drg.	App.Drg.	FIR	P	V	V	
e	Review of Testing and Measuring Instruments	To ensure the accuracy	Minor	Verification	100%	Calibration Certificate	National & International	TC	V	V	V	

NOTE 1: Only qualified welders & WPS to be used. In case welders are already qualified by customer / BHEL / LRIS / BVQI / DNV & doing similar jobs re-qualification is not required.

NOTE 2: Check Test shall be carried out on plates where ever correlation of TC with material is not available. Sample shall be identified & test Certificates shall be Verified by BHEL & CUSTOMER.

NOTE 3: All plates of pressure vessels shall be ultrasonically tested as follows:

(a) For nominal thickness 20 mm and higher when used for fabrication of dished ends

(b) For nominal thickness 40 mm and higher when used for fabrication of shells

(c) For nominal thickness 50 mm and higher when used for blind flanges

All thicknesses, when used for body flanges

NOTE 4: All test reports / Inspection reports related to the tank shall be furnished for BHEL / CUSTOMER review.

NOTE 5: Hydro test duration shall be 1hr at 1.5 times of design pressure or 2 times of working pressure whichever is higher & No Leakage will be permitted.

NOTE 6: The above mentioned quality inspection requirement are bare minimum. However any other test of any item as required by BHEL/Customer the same shall be provided by the bidder without and commercial and delivery implication to BHEL.

**ABBREVIATIONS:**

TC: Test Certificate  
DFT: Dry Film Thickness  
W: Witness

SIR: Stage Inspection Report  
App.Drg. Approved Drawing  
V: Verify Documents

FIR: Final Inspection Report  
P: Perform



**QUALITY ASSURANCE PLAN FOR CHILLER**

Sl.No.	Component & Operation	Characteristics	Class of check	Type of check	Quantum / Frequency of Check	Reference Document	Acceptance Standard	Format of Record	Scope of Check			Remarks
									BIDDER	BHEL	CUSTOMER	
<b>I ) Initial Procedure Qualifications :</b>												
a	Welding Procedure Qualification Tests	Procedure Qualification	Major	Visual & Mech Checks on Test Piece	100%	ASME SEC IX	ASME SEC IX	WPS - QW 482 & PQR - QW 483	P	V	V	<b>Note 1</b>
b	Welder Performance Qualification Tests	Performance Qualification	Major	Visual & Mech Checks on Test Piece	100%	ASME SEC IX	ASME SEC IX	WPQ - QW 484	P	V	V	<b>Note 1</b>
<b>II ) Raw Material Inspection :</b>												
a	Raw Material Identification for tubes,tube sheet Shell etc.	Verification of MTC & Chemical, Mechanical Properties	Major	Chemical & Mechanical Check	1 Per Heat / Lot	App.Drg. / Relevant code	App.Drg. / Relevant code	Mfr TC / Check Test Report	P	V	V	<b>Note 2 &amp; 3</b>
b	Surface Defects	Verification of Surface	Major	Visual	100%	No Pitting / Corrosion	No Pitting & Corrosion	SIR	P	V	V	
<b>III ) In Process Inspection :</b>												
a	Condenser Assembly	i. Pressure Test (Shell side)	Major	Pneumatic under water	100%	App.Drg.	No leakage	SIR	P	V	V	
		i. Pressure Test (Tube side)	Major	Hydraulic	100%	App.Drg.	No leakage	SIR	P	V	V	
b	Cooler Assembly	i. Pressure Test (Shell side)	Major	Pneumatic under water	100%	App.Drg.	No leakage	SIR	P	V	V	
		i. Pressure Test (Tube side)	Major	Hydraulic	100%	App.Drg.	No leakage	SIR	P	V	V	
<b>IV ) Stage Inspection</b>												
a	Dimension Check	Dimensional	Major	Measurement	100%	App.Drg.	App.Drg.	FIR	P	W	V	
b	Visual Check	Visual	Major	Visual Inspection	100%	App.Drg.	App.Drg.	FIR	P	W	V	
c	Pressure Test of Refrigerant System	Pneumatic	Critical	Pneumatic	100%	App.Drg.	No Leakage	FIR	P	W	W	

NOTE 1: Only qualified welders & WPS to be used. In case welders are already qualified by customer / BHEL / LRIS / BVQI / DNV & doing similar jobs re-qualification is not required.

NOTE 2: Check Test shall be carried out on plates where ever correlation of TC with material is not available. Sample shall be identified & test Certificates shall be Verified by BHEL & CUSTOMER.

NOTE 3: All plates of pressure vessels shall be ultrasonically tested as follows:

- (a) For nominal thickness 20 mm and higher when used for fabrication of dished ends
- (b) For nominal thickness 40 mm and higher when used for fabrication of shells
- (c) For nominal thickness 50 mm and higher when used for blind flanges

All thicknesses, when used for body flanges

NOTE 4: All test reports / Inspection reports related to the tank shall be furnished for BHEL / CUSTOMER review.

NOTE 5: Hydro test duration shall be 1hr at 1.5 times of design pressure or 2 times of working pressure whichever is higher & No Leakage will be permitted.

NOTE 6: The above mentioned quality inspection requirement are bare minimum. However any other test of any item as required by BHEL/Customer the same shall be provided by the bidder without and commercial and delivery implication to BHEL.

**ABBREVIATIONS:**

TC: Test Certificate  
DFT: Dry Film Thickness  
W: Witness

SIR: Stage Inspection Report  
App.Drg.: Approved Drawing  
V: Verify Documents

FIR: Final Inspection Report  
P: Perform

**THIS IS A PART OF TECHNICAL SPECIFICATION FOR OZONE GENERATION PLANT  
(TECHNICAL SPECIFICATION NUMBER: PE-TS-367-174-14000A-A001 REV 01)**

## QUALITY ASSURANCE PLAN FOR COMPRESSORS

SR. NO.	COMPONENTS AND OPERATORS	CHARACTERISTICS	CLASS	TYPE OF CHECK	QUANTUM OF CHECK		REFERENCE DOCUMENTS	ACCEPTANCE NORM	FORMAT OF RECORD	AGENCY			REMARKS	
					M	C/N				D	M	C		N
1	2	3	4	5	6	7	8	9	10	11	12	13	14	
<b>A. MATERIAL INSPECTION</b>														
1.1	ROTOR	PHYSICAL PROPERTIES CHEMICAL COMPOSITION HARDNESS INTERNAL DEFECTS DIMENSION	MAJOR " CRITICAL MAJOR	MECH. TEST CHEMICAL ANALYSIS HARDNESS CHECK ULTRASONIC TESTING MEASUREMENT	1/ BATCH  100% 100%		APPD DRG/DATA SHEET " " AC STANDARD MFG DRG	IN COMPLIANCE WITH "7" " " AC STANDARD MFG DRG	EN 10204-CI-2.2  COC Log book	√  √ V	V  V V	V  V V	V  V -	A- AIRPOWER  A- AIRPOWER  -
1.2	COMPRESSOR CASING / ROTOR HOUSING	CHEMICAL COMPOSITION  DIMENSION	MAJOR  MAJOR	CHEMICAL ANALYSIS  MEASUREMENT	1/BATCH  100%		APPD DRG/DATA SHEET  MFG DRG	IN COMPLIANCE WITH "7"  MFG DRG	EN 10204-CI-2.2  Log book	√  V	V  V	V  V	V  -	A- AIRPOWER  -
1.3	TIMING GEARS	PHYSICAL PROPERTIES CHEMICAL COMPOSITION HARDNESS DIMENSION	MAJOR " MAJOR	MECH. TEST CHEMICAL ANALYSIS HARDNESS CHECK MEASUREMENT	1/ BATCH  100%		APPD DRG/DATA SHEET " " MFG DRG	IN COMPLIANCE WITH "7" " " MFG DRG	EN 10204-CI-2.2  Log book	√  V	V  V	V  V	V  -	A- AIRPOWER  -
1.4	STEP UP GEARS	PHYSICAL PROPERTIES CHEMICAL COMPOSITION HARDNESS DIMENSION	MAJOR " MAJOR	MECH. TEST ANALYSIS HARDNESS CHECK MEASUREMENT	1/ BATCH  100%		APPD DRG/DATA SHEET " " MFG DRG	IN COMPLIANCE WITH "7" " " MFG DRG	EN 10204-CI-2.2  Log book	√  V	V  V	V  V	V  -	A- AIRPOWER  -
1.5	DRIVE SHAFT	PHYSICAL PROPERTIES CHEMICAL COMPOSITION HARDNESS INTERNAL DEFECTS DIMENSION	MAJOR " CRITICAL MAJOR	MECH. TEST CHEMICAL ANALYSIS HARDNESS CHECK ULTRASONIC TESTING MEASUREMENT	1/ BATCH  100% 100%		APPD DRG/DATA SHEET " " AC STANDARD MFG DRG	IN COMPLIANCE WITH "7" " " AC STANDARD MFG DRG	EN 10204-CI-2.2  COC Log book	√  √ V	V  V V	V  V V	V  V -	A- AIRPOWER  A- AIRPOWER  -
1.6	INTERCOOLER TUBES AFTER COOLER TUBES INTERCOOLER SHELL AFTER COOLER SHELL	MATERIAL CHECK	MAJOR	COMPOSITION TENSILE STRENGTH	1/ BATCH		APPD DRG/DATA SHEET	IN COMPLIANCE WITH "7"	COC	√	V	V	V	A- AIRPOWER
1.7	OIL COOLER PLATE TYPE	MATERIAL CHECK  DIMENSION CHECK	MAJOR  MAJOR	COMPOSITION TENSILE STRENGTH MEASUREMENT	1/BATCH  100%		APPD DRG/DATA SHEET  MFG DRG	IN COMPLIANCE WITH "7"  MFG DRG	COC  Log book	√  V	V  V	V  V	V  -	A- AIRPOWER  -
<small>                 LEGEND: * Remarks identified with "Tol" ) shall be as per the relevant standard or as per the QA document.                  M: Manufacturer / Sub Supplier, C: Supplier controlled inspection agency, RPL: Perform, W: Witness and V: Verification.                  A: Approve, CH: RPL / QA identify account "V"             </small>														

**THIS IS A PART OF TECHNICAL SPECIFICATION FOR OZONE GENERATION PLANT  
(TECHNICAL SPECIFICATION NUMBER: PE-TS-367-174-14000A-A001 REV 01)**

## QUALITY ASSURANCE PLAN FOR COMPRESSORS

SR. NO.	COMPONENTS AND OPERATORS	CHARACTERISTICS	CLASS	TYPE OF CHECK	QUANTUM OF CHECK		REFERENCE DOCUMENTS	ACCEPTANCE NORM	FORMAT OF RECORD	AGENCY			REMARKS	
					M	C				N	D	10		11
1	2	3	4	5	6	7	8	9	10	11	12	13		
					M	C/N								
<b>B INPROCESS INSPECTION</b>														
2.1	OIL COOLERS INTERCOOLER AFTERCOOLER	TIGHTNESS	MAJOR	HYDROSTATIC	100%		1.5 X DESIGN PRESSURE FOR 5 MIN.	NO LEAKAGE	COC (SEE NOTE2)	√	V	V	V	A- AIRPOWER
2.2	SAFETY VALVE	SET PRESSURE	MAJOR	MEASUREMENT	100%		AC STANDARD	AC STANDARD	COC	√	V	V	V	A- AIRPOWER
2.3	ROTOR ELEMENT	SURFACE FINISH	MAJOR	VISUAL	100%		AC STANDARD	AC STANDARD	COC	√	P/V	V	V	A- AIRPOWER
		COATING QUALITY	MAJOR	MEASUREMENT	100%		AC STANDARD	AC STANDARD	COC	√	P/V	V	V	A- AIRPOWER
		DYNAMIC BALANCING	MAJOR	BALANCING	100%		ISO 1940	ISO 1940 (grade 6.3 OR BETTER)	COC (SEE NOTE 3)	√	P/V	V	V	A- AIRPOWER
2.4	COMPRESSOR CASING / ROTOR HOUSING LP & HP.	DIMENSION CHECK	MAJOR	MEASUREMENT	100%		APPROVED DRG/ MFG DRG	IN COMPLIANCE WITH "7"	COC	√	P/V	V	V	A- AIRPOWER
		TIGHTNESS	MAJOR	HYDROTEST	100%		HYDROTEST	NO LEAKAGE	COC (SEE NOTE2)	√	P/V	V	V	A- AIRPOWER
2.5	AIR ENDS (HP & LP MODULE)	RUN TEST- FAD, LEAKAGE, ABNORMAL NOISE	MAJOR	FAD LEAKAGE ABNORMAL NOISE	100%		1.5 X DESIGN PR AIRPOWER STDS. / ISO 1217	IN COMPLIANCE WITH "7"	COC	√	P	V	V	A- AIRPOWER
2.6A	ELECTRONIKON MICROPROCESSOR MODULE	FUNCTIONAL INTERLOCKS ALARMS	MAJOR	FUNCTIONAL TEST	100%		INT DRAWING	IN COMPLIANCE WITH "7"	COC	√	V	V	V	A- AIRPOWER
2.6B	CONTROL PANEL (ELECTRONIKON + ** CONTACTORS + ** WIRING HARNESS)	FUNCTIONAL CHECK: DISPLAY, INTERLOCKS, ALARMS ETC	MAJOR	MEASUREMENT	100%		APPRD DRG/ INT DRAWING	APPRD DRG/ INT DRAWING	INSP REPORT	√	P	V	V	** B - AC INDIA
2.7	OIL FILTER AIR FILTER THROTTLE VALVE OIL PUMP	FITMENT / APPEARANCE	MAJOR	VISUAL	1/BATCH		INT DRAWING	INT DRAWING	COC	√	V	V	V	A- AIRPOWER
		PERFORMANCE		VERIFICATION	1/BATCH				COC	√	V	V	V	A- AIRPOWER
		PERFORMANCE		VERIFICATION	100%				COC	√	V	V	V	A- AIRPOWER
2.8	CANOPY BASE FRAME VENTILATION FAN	COMPLETENESS	MAJOR	VISUAL	100%		APPRD DRG/ INT DRAWING	APPRD DRG/ INT DRAWING	INSP REPORT	√	P	V	V	B- AC INDIA
		DIMENSIONS		MEASUREMENT	100%		INT DRAWING	PROPER MOUNTING						

LEGEND: \* Record identified with "Tick" ( ) shall be explicitly included by supplier in COC documentation.  
 \*\* M- Manufacturer; S- Sub Supplier; C- Supplier nominated inspection agency; N- RPCL; P- Purifier; W- Washes and V- Ventilator.  
 As appropriate CHP/ RPCL shall identify in column "11".

**THIS IS A PART OF TECHNICAL SPECIFICATION FOR OZONE GENERATION PLANT  
(TECHNICAL SPECIFICATION NUMBER: PE-TS-367-174-14000A-A001 REV 01)**

## QUALITY ASSURANCE PLAN FOR COMPRESSORS

SR. NO.	COMPONENTS AND OPERATORS	CHARACTERISTICS	CLASS	TYPE OF CHECK	QUANTUM OF CHECK		REFERENCE DOCUMENTS	ACCEPTANCE NORM	FORMAT OF RECORD	AGENCY			REMARKS	
					M	C				N				
1	2	3	4	5	6	7	8	9	D	10	11	11		
					M	C/N								
	<b>C FINAL INSPECTION</b>													
3.0	OVERALL ASSLY. ALONG WITH MOTOR, CONTROL PANEL AND OTHER ACC	DIMENSION COMPLETENESS	MAJOR	MEASUREMENT VISUAL	100%	100%	APPROVED DRG	APPROVED DRG	INSP. REPORT	√	P	W	W	B-AC INDIA
		TIGHTNESS OF AIR/OIL/WATER LINE	MAJOR	VISUAL	100%	100%	NO LEAKAGE	NO LEAKAGE	INSP. REPORT	√	P	W	W	B- AC INDIA
3.1	RUN TEST AND PERFORMANCE TEST	FREE AIR DELIVERY AIR OUTLET PRESSURE SPECIFIC POWER NOISE & VIBRATIONS (SEE NOTE 5)	CRITICAL	OPERATION & CONFORMANCE	100%	100%	APPD. DATA SHEETS / DRGS & ISO 1217	APPD. DATA SHEETS / DRGS	INSP. REPORT	√	P	W	W	CHP- TESTING WITH CONTRACT MOTOR AND CONTROL PANEL AT AC INDIA Sveanagar, Dapodi Pune 411012
	<b>D PACKING AND DESPATCH</b>													
4	PACKING SHIPPING	PACKING AND TRANSPORTATION	MAJOR	VERIFICATION	100%		AS PER PACKING PROCEDURE	AS PER PACKING PROCEDURE	ALL SHIPPING DOCUMENTS		P/V	V		B - AC INDIA
<b>REMARKS</b> A- PERFORMED / ISSUED BY <b>BIDDER</b> B- PERFORMED / ISSUED BY <b>BIDDER</b> NOTE 1 MATERIAL SHALL BE AS PER APPROVED DRG/TDS. INCASE NOT MENTIONED IN APPROVED DRG/TDS THEN AC STANDARDS SHALL BE APPLICABLE NOTE 2 SPECIFIC CONFIRMATION FROM AIRPOWER REGARDING THE HYDROTEST PRESSURE NOTE 3 SPECIFIC CONFIRMATION FROM AIRPOWER REGARDING THE BALANCING STD AND THE GRADE OF BALANCING NOTE 4 EN 10204 CL 2.2 CERTIFICATE : DOCUMENT IN WHICH MANUFACTURER DECLARES THAT THE PRODUCTS SUPPLIED ARE IN COMPLIANCE WITH THE REQUIREMENTS OF THE ORDER AND IN WHICH HE SUPPLIES TEST RESULTS BASED ON NON SPECIFIC INSPECTION NOTE 5 NOISE & VIBRATION MEASURED AT SHOP FOR REFERENCE PURPOSE. HOWEVER VALUES SHALL BE DEMONSTRATED AT SITE. AS PER APPROVED TDS NOTE 6 DRIVE MOTOR INSPECTION AND TESTING AS PER SEPARATE APPROVED QP NOTE 7 CALIBRATION STATUS OF MEASURING INSTRUMENTS USED FOR PERFORMANCE TESTING SHALL BE VERIFIED DURING INSPECTION <b>NOTE 8</b> The above mentioned quality inspection requirement are bare minimum. However any other test of any item as required by BHEL/Customer the same shall be provided by the bidder without and commercial and delivery implication to BHEL.														



**TITLE:**

**TECHNICAL SPECIFICATION FOR  
OZONE GENERATION PLANT**

**1X700 MW BELLARY THERMAL POWER  
STATION UNIT NO. 3, STAGE-3**

BHEL DOCUMENTS NO.: PE-TS-367-174-14000A-A001

VOLUME **II-B**

SECTION -C2

REV. NO. 01

DATE: 24/02/2014

## **SECTION C2**

### **SPECIFIC TECHNICAL REQUIREMENTS FOR ELECTRICAL**



TECHNICAL SPECIFICATION FOR  
**OZONE GENERATION PLANT**  
**(ELECTRICAL PORTION)**

SPEC NO. PE-TS-367-174-14000A-A001

VOLUME II B  
SECTION-C2  
REV 01  
PAGE 1 OF 1

DATE 24.02.2014

**ELECTRICAL EQUIPMENT SEPCIFICATION FOR OZONE GENERATION PLANT**

1.0 EQUIPMENT & SERVICES TO BE PROVIDED BY BIDDER/ PURCHASER

- 1.1 Scope for supply, and erection & commissioning of various equipment forming part of electrical system for this package shall be as per Annexure-I to Section -C2 [Electrical Scope between BHEL & Vendor].
- 1.2 Make of various equipment/ items in the scope of bidder shall be to approval of owner during detailed engineering stage without any commercial implications.
- 1.3 Bidder shall furnish all 415V AC loads required for the system such as motor feeders, supply feeders in PEM format along with the offer.
- 1.4 All electrical equipment shall be suitable for the power supplies, fault levels and climatic conditions indicated in project information enclosed with the specification.
- 1.5 All drawings, data sheets, Quality Plan, calculations, test reports, test certificates, etc. shall be submitted during detailed engineering stage. The same shall be subject to approval without any commercial implications.
- 1.6 Technical requirements shall be as per specifications listed in Clause 4.1, 4.2, 4.3& 4.4 below.

3.0 DOCUMENTS TO BE SUBMITTED ALONG WITH BID

- 3.1 Bidder shall confirm total compliance to the electrical specification without any deviation from the technical/ quality assurance requirements stipulated. In line with this, the bidder as technical offer shall furnish two signed and stamped copies of the following:
  - a) A copy of this sheet "Electrical Equipment Specification for Ozone Generation plant System and sheet "Electrical Scope between BHEL and Vendor" with bidder's signature and company stamp.
  - b) List of Erection and Commissioning spares.
  - c) List of Erection & Maintenance tools & tackles.
  - d) Electrical load requirement in the load data format.
- 3.2 No technical submittal such as copies of data sheets, drawings, write-up, quality plans, type test certificates, technical literature, etc. is required during tender stage. Any such submission even if made, shall not be considered as part of offer.

4.0 LIST OF ENCLOSURES

- 4.1 Electrical Scope Matrix between BHEL & vendor (Annexure-I).
- 4.2 Technical specification and Data Sheets for 415V Electric Motors.
- 4.3 Technical Specification for Power, Control, Instrumentation Control Cable & Miscellaneous electrical item
- 4.4 Quality Plan for motors, Power, Control & Screened control cables.
- 4.5 Load data format (Annexure-II).



**TITLE:**

**TECHNICAL SPECIFICATION FOR  
OZONE GENERATION PLANT**

**1X700 MW BELLARY THERMAL POWER  
STATION UNIT NO. 3, STAGE-3**

BHEL DOCUMENTS NO.: PE-TS-367-174-14000A-A001

VOLUME **II-B**

SECTION -C2

REV. NO. 01

DATE: 24/02/2014

## **ELECTRICAL SCOPE BETWEEN BHEL AND VENDOR**

## ANNEXURE – I TO SECTION – C2: STANDARD ELECTRICAL SCOPE BETWEEN BHEL AND VENDOR

**PROJECT: 1X700 MW BELLARY THERMAL POWER  
STATION UNIT NO. 3, STAGE-3**

**PACKAGE: OZONE GENERATION PLANT (CIVIL IN BHEL SCOPE)**

S.NO	DETAILS	SCOPE SUPPLY	SCOPE E&C	REMARKS
1	415V MCC	BHEL	BHEL	<ol style="list-style-type: none"> <li>415 V AC(3-Ph, 4Wire)/240 V AC supply shall be provided by BHEL based on load data provided by vendor at contract stage for all equipment supplied by vendor as part of contract including power supply equipment (battery charger etc) required for the PLC/control panel (as applicable) for the system supplied by vendor. Any other voltage level shall be in the scope of vendor.</li> <li>Interposing relays (RE 302 of Jyoti make or equivalent), if required for PLC and microprocessor based systems, shall be provided by BHEL in MCCs. Requirement of these relays shall be furnished by vendor during detailed engineering stage.</li> </ol>
2	Local Push Button Station (for motors)	VENDOR	VENDOR	Located near the motor.
3	Power cables, control cables and screened control cables for a) both end equipment in BHEL's scope b) both end equipment in vendor's scope c) one end equipment in vendor's scope	BHEL BHEL BHEL	BHEL Vendor BHEL	<ol style="list-style-type: none"> <li>Sizes and quantity of cables required shall be informed by vendor at contract stage (based on inputs provided by BHEL). Finalisation of cable sizes shall be done by BHEL. Vendor shall provide lugs &amp; glands accordingly.</li> <li>Laying of cables by BHEL except for cabling in vendor scope.</li> <li>Termination at BHEL equipment terminals by BHEL.</li> <li>Termination at Vendor equipment terminals by Vendor.</li> </ol>
4	Any special type of cable like compensating, co-axial, prefab, MICC, fibre optical etc.	Vendor	Vendor	
5	Cable trays, accessories & cable trays supporting system	BHEL	BHEL	
6	Cable glands and lugs for equipments supplied by Vendor	Vendor	Vendor	<ol style="list-style-type: none"> <li>Double compression Ni-Cr plated brass cable glands</li> <li>Solder less crimping type heavy duty tinned copper lugs for power cables</li> <li>Solder less crimping type heavy duty copper lugs for control cables.</li> </ol>
7	Conduit and conduit accessories for cabling between equipments supplied by vendor	Vendor	Vendor	Conduits shall be medium duty, hot dip galvanised cold rolled mild steel rigid conduit as per IS: 9537. Makes of conduits shall be subject to customer/ BHEL approval at contract stage.

## ANNEXURE – I TO SECTION – C: STANDARD ELECTRICAL SCOPE BETWEEN BHEL AND VENDOR

PROJECT: 1x700MW BELLARY-3 TPS

PACKAGE: OZONE GENERATION PLANT (CIVIL IN BHEL SCOPE)

S.NO	DETAILS	SCOPE SUPPLY	SCOPE E&C	REMARKS
8	Lighting	BHEL	BHEL	
9	Lightning protection	BHEL	BHEL	
10	Equipment grounding	Vendor	Vendor	
11	Below grade grounding	BHEL	BHEL	
12	LT Motors with base plate and foundation hardware	Vendor	Vendor	Makes shall be subject to customer/ BHEL approval at contract stage.
13	Mandatory spares (if applicable)	Vendor -		Vendor to quote as per specification.
14	Recommended O & M spares, E & C spares, erection & maintenance tools & tackle.	Vendor	-	As per specification
15	Any other equipment/material/service required for completeness of system but not specified above (to ensure trouble free and efficient operation of the system).	Vendor	Vendor	
16	a) Input cable schedules (C & I) b) Cable interconnection details for above c) Cable block diagram	Vendor Vendor Vendor	- - -	Cable listing for C & I systems for vendor supplied equipment shall be furnished during detail engineering by vendor in soft copies in the BHEL cable schedule format.
17	Equipment layout drawings	Vendor	-	For ensuring cabling requirements are met, vendor shall furnish layout drawings (both in print form as well as in AUTOCAD) of the complete plant (including electrical area) indicating location and identification of all equipments requiring cabling, and shall incorporate cable trays routing details marked on the drawing as per PEM interface comments. Electrical equipment layout drawing shall be to BHEL approval.
18	Electrical Equipment GA drawing	Vendor	-	For necessary interface review.

NOTES:

1. Make of all electrical equipments/items supplied shall be reputed make & shall be subject to approval of BHEL/customer after award of contract.
2. All QPs shall be subject to approval of BHEL/customer after award of contract without any commercial implication.



**TITLE:**  
**TECHNICAL SPECIFICATION FOR  
OZONE GENERATION PLANT**  
**1X700 MW BELLARY THERMAL POWER  
STATION UNIT NO. 3, STAGE-3**

BHEL DOCUMENTS NO.: PE-TS-367-174-14000A-A001

VOLUME **II-B**

SECTION -C2

REV. NO. 01

DATE: 24/02/2014

## ELECTRICAL LOAD FORMAT

LOAD TITLE	RATING (KW / A)		UNIT (U)/STN (S)	Nos.		VOLTAGE CODE*	FEEDER CODE**	EMER. LOAD (Y)	CONT.(C)/ INTT.(I)	STARTING TIME >5 SEC (Y)	LOCATION	BOARD NO.	CABLE		BLOCK CABLE DRG. No.	CONTROL CODE	REMARKS	LOAD No.
	NAME PLATE	MAX. CONT. DEMAND (MCR)		RUNNING	STANDBY								SIZE CODE	NOs				
1	2	3	4	5	6	7	8	9	10	11	12	13	14	15	16	17	18	19

**ANNEXURE-II**

**NOTES:** 1. COLUMN 1 TO 12 & 18 SHALL BE FILLED BY THE REQUISITIONER (ORIGINATING AGENCY); REMAINING COLUMNS ARE TO BE FILLED UP BY PEM (ELECTRICAL)  
2. ABBREVIATIONS : \* VOLTAGE CODE (7):- (ac) A=11 KV, B=6.6 KV, C=3.3 KV, D=415 V, E=240 V (1 PH), F=110 V (DC): G=220 V, H=110 V, J=48 V, K=+24V, L=-24 V  
: \*\* FEEDER CODE (8):- U=UNIDIRECTIONAL STARTER, B=BI-DIRECTIONAL STARTER, S=SUPPLY FEEDER, D=SUPPLY FEEDER (CONTACTER CONTROLLED)

	<b>LOAD DATA (ELECTRICAL)</b>	JOB NO.	367	ORIGINATING AGENCY		PEM (MAUX)	
		PROJECT TITLE	BELLARY-3 TPS,1X700 MW	NAME		DATA FILLED UP ON	
		SYSTEM	OZONE GENERATION PLANT	SIGN.		DATA ENTERED ON	
		DEPTT. / SECTION	MAUX	SHEET 1 OF 1	REV. 00	DE'S SIGN. & DATE	Page 58 of 217



**TITLE:**

**TECHNICAL SPECIFICATION FOR  
OZONE GENERATION PLANT**

**1X700 MW BELLARY THERMAL POWER  
STATION UNIT NO. 3, STAGE-3**

BHEL DOCUMENTS NO.: PE-TS-367-174-14000A-A001

VOLUME **II-B**

SECTION -C2

REV. NO. 01

DATE: 24/02/2014

## QUALITY PLAN FOR MOTORS

THIS IS A PART OF TECHNICAL SPECIFICATION FOR OZONE GENERATION PLANT  
(TECHNICAL SPECIFICATION NUMBER: PE-TS-367-174-14000A-A001 REV 01)

QUALITY PLAN			CUSTOMER			PROJECT TITLE			SPECIFICATION NUMBER			
SHEET 1 OF 9			BIDDER/VENDOR			QUALITY PLAN NUMBER PED-506-00-Q-007 REV-03			SPECIFICATION TITLE			
SL. NO.	COMPONENT/OPERATION	CHARACTERISTIC CHECK	CAT.	TYPE/METHOD OF CHECK	EXTENT OF CHECK	REFERENCE DOCUMENT	ACCEPTANCE NORM	FORMAT OF RECORD	SECTION AGENCY			REMARKS
									P	W	V	
1	2	3	4	5	6	7	8	9	10			11
1.0	RAW MATERIAL & BOUGHT OUT CONTROL											
1.1	SHEET STEEL, PLATES, SECTION, EYEBOLTS	1.SURFACE CONDITION	MA	VISUAL	100%	-	FREE FROM BLINKS, CRACKS, WAVINESS ETC	LOG BOOK	3	-	-	
		2.DIMENSIONS	MA	MEASUREMENT	SAMPLE	MANFR'S DRG./SPEC	MANFR'S DRG./SPEC	-DO-	3	-	-	
		3.PROOF LOAD TEST (EYE BOLT)	MA	MECH. TEST	-DO-	-DO-	-DO-	INSPEC. REPORT	3	-	2	
1.2	HARDWARES	1.SURFACE CONDITION	MA	VISUAL	100%		FREE FROM CRACKS, UNEVENNESS ETC.	-DO-	3	-	-	
		2.PROPERTY CLASS	MA	VISUAL	SAMPLES	MANFR'S DRG./SPEC BOOK	RELEVANT IS/SPEC.	SUPPLIER'S TC & LOG	3	-	2	PROPERTY CLASS MARKING SHALL BE CHECKED BY THE VENDOR
1.3	CASTING	1.SURFACE CONDITION	MA	VISUAL	100%		FREE FROM CRACKS, BLOW HOLES ETC.	LOG BOOK	3	-	2	
		2.CHEM. & PHY. PROP.	MA	CHEM & MECH TEST	1/HEAT NO.	MANFR'S DRG./SPEC	RELEVANT IS/	SUPPLIER'S TC	3	-	2	HEAT NO. SHALL BE VERIFIED
		3.DIMENSIONS	MA	MEASUREMENT	100%	MANUFR'S DRG.	MANUFR'S DRG.	LOG BOOK	3	-	2	
1.4	PAINT & VARNISH	1.MAKE, SHADE, SHELF LIFE & TYPE	MA	VISUAL	100% CONTINUOUS	MANFR'S DRG./SPEC	MANFR'S DRG./SPEC	LOG BOOK	3	-	2	
BHEL			PARTICULARS			BIDDER/VENDOR						
			NAME									
			SIGNATURE									
			DATE									BIDDER'S/VENDORS COMPANY SEAL

THIS IS A PART OF TECHNICAL SPECIFICATION FOR OZONE GENERATION PLANT  
(TECHNICAL SPECIFICATION NUMBER: PE-TS-367-174-14000A-A001 REV 01)

		QUALITY PLAN			CUSTOMER			PROJECT			SPECIFICATION		
		SHEET 2 OF 9			BIDDER/ VENDOR			TITLE			NUMBER		
		SYSTEM			SYSTEM			QUALITY PLAN NUMBER PED-508-00-Q-007, REV-03			SPECIFICATION TITLE		
		ITEM: AC ELECT. MOTORS 55 KW & ABOVE (LV & MV)			SECTION			FORMAT OF RECORD			VOLUME III		
SL. NO.	COMPONENT/OPERATION	CHARACTERISTIC CHECK	CAT.	TYPE/ METHOD OF CHECK	EXTENT OF CHECK	REFERENCE DOCUMENT	ACCEPTANCE NORM		AGENCY			REMARKS	
									P	W	V		
1	2	3	4	5	6	7	8	9	10			11	
1.5	SHAFT (FORGED OR ROLLED)	1. SURFACE COND.	MA	VISUAL	100%	-	FREE FROM VISUAL DEFECTS	-DO-	3	-	-	VENDOR'S APPROVAL IDENTIFICATION SHALL BE MAINTAINED	
		2. CHEM. & PHYSICAL PROPERTIES	MA	CHEM. & PHYSICAL TESTS	1/HEAT NO. OR HEAT TREATMENT BATCH NO	MFG. DRG. SPEC.	RELEVANT IS	SUPPLIER'S TC	3	-	2		
		3. DIMENSIONS	MA	MEASUREMENT	100%	-DO-	MANUFR'S DRG.	LOG BOOK	3	-	2		
		4. INTERNAL FLAWS	CR	UT	-DO-	ASTM-A388	MANUFR'S SPEC. BHEL SPEC.	-DO-	3	2	1		FOR DIA OF 55 MM & ABOVE
1.6	SPACE HEATERS, CONNECTORS, TERMINAL BLOCKS, CABLES, CABLE LUGS, CARBON BRUSH TEMP. DETECTORS, RTD, BTD'S	1. MAKE & RATING	MA	VISUAL	-DO-	MANUFR'S DRG. SPEC.	MANUFR'S DRG. SPEC.	-DO-	3	-	2		
		2. PHYSICAL COND.	MA	-DO-	-DO-	-	NO PHYS. DAMAGE NO ELECTRICAL DISCONTINUITY	-DO-	3	-	2		
		3. DIMENSIONS (WHEREVER APPLICABLE)	MA	MEASUREMENT	SAMPLE	MANUFR'S DRG./ SPEC.	MANUFR'S DRG. / SPEC.	-DO-	3	-	2		
		4. PERFORMANCE/ CALIBRATION	MA	TEST	100%	-DO-	-DO-	INSP. REPORT	3	-	2		
BHEL			PARTICULARS			BIDDER/VENDOR							
			NAME										
			SIGNATURE										
			DATE						BIDDER'S/VENDORS COMPANY SEAL				

THIS IS A PART OF TECHNICAL SPECIFICATION FOR OZONE GENERATION PLANT  
(TECHNICAL SPECIFICATION NUMBER: PE-TS-367-174-14000A-A001 REV 01)

		QUALITY PLAN			CUSTOMER				PROJECT			SPECIFICATION		
		SHEET 3 OF 9			BIDDER/ VENDOR				TITLE			NUMBER		
SYSTEM		SYSTEM			ITEM: AC ELECT. MOTORS 55 KW & ABOVE (LV & MV)				SECTION			VOLUME III		
SL. NO.	COMPONENT/OPERATION	CHARACTERISTIC CHECK	CAT.	TYPE/ METHOD OF CHECK	EXTENT OF CHECK	REFERENCE DOCUMENT	ACCEPTANCE NORM	FORMAT OF RECORD	AGENCY			REMARKS		
									P	W	V			
1	2	3	4	5	6	7	8	9	10			11		
1.7	OTHER INSULATING MATERIALS LIKE SLEEVES, BINDINGS CORDS, PAPERS, PRESS BOARDS ETC.	1. SURFACE COND. ETC.	MA	VISUAL	100%	-	NO VISUAL DEFECTS	INSPT. REPORT	3	-	2			
		2. OTHER CHARACTERISTICS	MA	TEST	SAMPLE	-	MANUF'S SPEC.	LOG BOOK AND OR SUPPLIER'S TC	3	-	2			
1.8	SHEET STAMPING (PUNCHED)	1. SURFACE COND.	MA	VISUAL	100%	-	NO VISUAL DEFECTS (FREE FROM BURS)	LOG BOOK	3	-	-			
		2. DIMENSIONS INCLUDING BURS HEIGHT	MA	MEASUREMENT	SAMPLE	-	MANUF'S DRG.	-DO-	3	-	2			
		3. ACCEPTANCE TESTS	MA	ELECT. & MECH TESTS	-DO-	-	MANUF'S SPEC / RELEVANT IS	RELEVANT IS	SUPPLIER'S TC	3	-		2	
1.9	CONDUCTORS	1. SURFACE FINISH	MA	VISUAL	100%	-	FREE FROM VISUAL DEFECTS	LOG BOOK	3*	-	2*	* MOTOR MANUFACTURER TO CONDUCT VISUAL CHECK FOR SURFACE FINISH ON RANDOM BASIS (10% SAMPLE) AT HIS WORKS AND MAINTAIN RECORD FOR VERIFICATION BY BHEL/CUSTOMER.		
		2. ELECT. PROP. & MECH. PROP	MA	ELECT. & MECH. TEST	SAMPLES	-	RELEVANT IS/ BS OR OTHER STANDARDS	RELEVANT IS/ BS OR OTHER STANDARDS	SUPPLIER'S TC & VENDOR'S INSPN. REPORTS	3	-		2	
<b>BHEL</b>			<b>PARTICULARS</b>			<b>BIDDER/VENDOR</b>								
			NAME											
			SIGNATURE											
			DATE						BIDDER'S/VENDORS COMPANY SEAL					

THIS IS A PART OF TECHNICAL SPECIFICATION FOR OZONE GENERATION PLANT  
(TECHNICAL SPECIFICATION NUMBER: PE-TS-367-174-14000A-A001 REV 01)

		QUALITY PLAN			CUSTOMER :				PROJECT TITLE			SPECIFICATION NUMBER		
SHEET 4 OF 9		BIDDER/VENDOR SYSTEM			ITEM AC ELECT. MOTORS 55 KW & ABOVE (LV & MV)				SECTION			VOLUME III		
SL. NO.	COMPONENT/OPERATION	CHARACTERISTIC CHECK	CAT.	TYPE/METHOD OF CHECK	EXTENT OF CHECK	REFERENCE DOCUMENT	ACCEPTANCE NORM	FORMAT OF RECORD	P	W	V	REMARKS		
1	2	3	4	5	6	7	8	9	10			11		
1.10	BEARINGS	3.DIMENSIONS	MA	MEASUREMENT	-DO-	-DO-	-DO-	Log Book	3	-	2			
		1.MAKE & TYPE	MA	VISUAL	100%	MANFR'S DRG./ APPROVED DATASHEET	MANFR'S DRG./ APPROVED DATASHEET	-DO-	3	-	2			
		2.DIMENSIONS	MA	MEASUREMENT	SAMPLE	BHEL DATA SHEET	BHEL DATA SHEET BEARING MANUF'S CATALOGUES	-DO-	3	-	2			
1.11	SLIP RING (WHEREVER APPLICABLE)	3.SURFACE FINISH	MA	VISUAL	100%	-	FREE FROM VISUAL DEFECTS	-DO-	3	-	2			
		1.SURFACE COND.	MA	VISUAL	100%	-	-DO-	-DO-	3	-	-			
		2.DIMENSIONS	MA	MEASUREMENT	SAMPLE	MANUF'S DRG	MANUF'S DRG	-DO-	3	-	-			
		3.TEMP. WITH-STAND CAPACITY	MA	ELECT.TEST	-DO-	MANUF'S SPEC./ BHEL SPEC.	MANUF'S SPEC./ BHEL SPEC.	-DO-	3	-	2			
1.12	OIL SEALS & GASKETS	4.HVIR	MA	-DO-	100%	-DO-	-DO-	-DO-	3	-	2			
		1.MATERIAL OF GASKET	MA	VISUAL	100%	MANUF'S DRG/SPECS	MANUF'S DRG./ SPECS.	-DO-	3	-	-			
		2.SURFACE COND.	MA	VISUAL	100%	-	FREE FROM VISUAL DEFECTS	-DO-	3	-	-			
		3.DIMENSIONS	MA	MEASUREMENT	SAMPLE	MANUF'S DRG	MANUF'S DRG	-DO-	3	-	-			
BHEL			PARTICULARS			BIDDER/VENDOR								
			NAME											
			SIGNATURE											
			DATE			BIDDER'S/VENDORS COMPANY SEAL								

THIS IS A PART OF TECHNICAL SPECIFICATION FOR OZONE GENERATION PLANT  
(TECHNICAL SPECIFICATION NUMBER: PE-TS-367-174-14000A-A001 REV 01)

		QUALITY PLAN			CUSTOMER			PROJECT			SPECIFICATION :		
		SHEET 5 OF 9			BIDDER/ VENDOR			TITLE			NUMBER :		
		SYSTEM			ITEM: AC ELECT. MOTORS 55 KW & ABOVE (LV & MV)			QUALITY PLAN NUMBER PED-508-00-Q-007, REV-03			SPECIFICATION TITLE		
SL. NO.	COMPONENT/OPERATION	CHARACTERISTIC CHECK	CAT.	TYPE/ METHOD OF CHECK	EXTENT OF CHECK	REFERENCE DOCUMENT	ACCEPTANCE NORM	FORMAT OF RECORD	AGENCY			REMARKS	
									P	W	V		
1	2	3	4	5	6	7	8	9	10			11	
2.0	IN PROCESS												
2.1	STATOR FRAME WELDING (IN CASE OF FABRICATED STATOR )	1.WORKMANSHIP & CLEANNESS	MA	VISUAL	100%	-DO-	GOOD FINISH	LOG BOOK	3/2	2	-		
		2.DIMENSIONS	MA	MEASUREMENT	-DO-	MANUF'S DRG	MANUF'S DRG	-DO-	2	-	-		
2.2	MACHINING	1.FINISH	MA	VISUAL	100%	-DO-	GOOD FINISH	LOG BOOK	2	-	-		
		2.DIMENSIONS	MA	MEASUREMENT	-DO-	MANUF'S DRG	MANUF'S DRG	-DO-	2	-	-		
		3.SHAFT SURFACE FLOWS	MA	PT	-DO-	RELEVANT SPEC./ ASTM-E165	MANUF'S SPEC./ BHEL SPEC./	-DO-	2	-	1		
2.3	PAINING	1.SURFACE PREPARATION	MA	VISUAL	100%	MANFR'S SPEC/BHEL SPEC./ RELEVANT STAND	BHEL SPEC. SAME AS COL.7	LOG BOOK	2	-	-		
		2.PAINT THICKNESS (BOTH PRIMER & FINISH COAT)	MA	MEASUREMENT BY ELCOMETER	SAMPLE	-DO-	-DO-	-DO-	2	-	-		
		3.SHADE	MA	VISUAL	-DO-	-DO-	-DO-	Log Book	2	-	-		
		4.ADHESION	MA	CROSS CUTTING & TAPE TEST	-DO-	-DO-	-DO-	Log Book	2	-	-		
BHEL			PARTICULARS			BIDDER/VENDOR							
			NAME										
			SIGNATURE										
			DATE						BIDDER'S/VENDORS COMPANY SEAL				

THIS IS A PART OF TECHNICAL SPECIFICATION FOR OZONE GENERATION PLANT  
(TECHNICAL SPECIFICATION NUMBER: PE-TS-367-174-14000A-A001 REV 01)

 <b>QUALITY PLAN</b>			CUSTOMER			PROJECT TITLE			SPECIFICATION NUMBER				
SHEET 6 OF 9			BIDDER/VENDOR			QUALITY PLAN NUMBER PED-508-00-Q-007, REV-03			SPECIFICATION TITLE				
SL. NO.	COMPONENT/OPERATION	CHARACTERISTIC CHECK	SYSTEM			ITEM: AC ELECT. MOTORS 55 KW & ABOVE (LV & MV)			SECTION			REMARKS	
			CAT.	TYPE/METHOD OF CHECK	EXTENT OF CHECK	REFERENCE DOCUMENT	ACCEPTANCE NORM	FORMAT OF RECORD	AGENCY				
1	2	3	4	5	6	7	8	9	10	11			
2.4	SHEET STACKING	1.COMPLETENESS	MA	MEASUREMENT	SAMPLE	MANUFR'S SPEC.	MANUFR'S SPEC.	Log Book	2	-	-	(FOR MOTORS OF 2MW AND ABOVE) * ON 10% RANDOM SAMPLE	
		2.COMPRESSION & TIGHTENING	MA	MEASUREMENT	100%	-DO-	-DO-	Log Book	2	-	-		
		3.CORE LOSS & HOTSPOT	MA	ELECT.TEST	-DO-	-DO-	-DO-	Log Book	2	1*	1		
2.5	WINDING	1.COMPLETENESS	CR	VISUAL	100%	MANUFR'S SPEC./BHEL SPEC.	MANUFR'S SPEC./BHEL SPEC.	Log Book	2	-	-		
		2.CLEANLINESS	CR	-DO-	-DO-	-DO-	-DO-	Log Book	2	-	-		
		3.IR-HV-IR	CR	ELECT. TEST	-DO-	-DO-	-DO-	Log Book	2	-	1		
		4.RESISTANCE	CR	-DO-	-DO-	-DO-	-DO-	Log Book	2	-	1		
		5.INTERTURN INSULATION	CR	-DO-	-DO-	-DO-	-DO-	Log Book	2	-	-		
		6.SURGE WITH STAND AND TAN, DELTA TEST	CR	-DO-	-DO-	-DO-	-DO-	Log Book	2	-	1		FOR MV MOTOR
2.6	IMPREGNATION	1.VISCOSCITY	MA	PHY. TEST	AT STARTING	-DO-	-DO-	Log Book	2	-	-		
		2.TEMP. PRESSURE VACCUM	MA	PROCESS CHECK	CONTINUOUS	-DO-	-DO-	Log Book	2	-	-		
		3.NO. OF DIPS	MA	-DO-	-DO-	-DO-	-DO-	Log Book	2	-	1	THREE DIPS TO BE GIVEN	
<b>BHEL</b>			<b>PARTICULARS</b>			<b>BIDDER/VENDOR</b>							
			NAME										
			SIGNATURE										
			DATE						BIDDER'S/VENDORS COMPANY SEAL				

THIS IS A PART OF TECHNICAL SPECIFICATION FOR OZONE GENERATION PLANT  
(TECHNICAL SPECIFICATION NUMBER: PE-TS-367-174-14000A-A001 REV 01)

 <b>QUALITY PLAN</b>			CUSTOMER				PROJECT TITLE			SPECIFICATION NUMBER		
SHEET 7 OF 9			BIDDER/VENDOR				QUALITY PLAN NUMBER PED-506-00-Q-007, REV-03			SPECIFICATION TITLE		
SL. NO.	COMPONENT/OPERATION	CHARACTERISTIC CHECK	CAT.	TYPE/METHOD OF CHECK	EXTENT OF CHECK	REFERENCE DOCUMENT	ACCEPTANCE NORM	FORMAT OF RECORD	SECTION			REMARKS
									P	W	V	
1	2	3	4	5	6	7	8	9	10			11
2.7	COMPLETE STATOR ASSEMBLY	4.DURATION 1.COMPACTNESS & CLEANLINESS	MA	-DO-	-DO-	-DO-	-DO-	Log Book	2	-	1	
2.8	BRAZING/COMPRESSION JOINT	1.COMPLETENESS 2.SOUNDNESS	CR	-DO-	-DO-	-DO-	-DO-	Log Book	2	-	-	
		3.HV	CR	MALLET TEST & UT	-DO-	-DO-	-DO-	Log Book	2	-	1	
2.9	COMPLETE ROTOR ASSEMBLY	1.RESIDUAL UNBALANCE 2.SOUNDNESS OF DIE CASTING	MA	ELECT. TEST	-DO-	-DO-	-DO-	Log Book	2	-	1	
		3.DYN. BALANCE	CR	DYN. BALANCE	-DO-	MFG SPEC./ ISO 1940	MFG. DWG.	Log Book	2	-	1	VERIFICATION FOR MV MOTOR ONLY
		4.ELECT. (GROWLER TEST)	CR	ELECT. (GROWLER TEST)	-DO-	MFG. SPEC.	MFG. SPEC.	Log Book	2	-	1	
2.10	ASSEMBLY	1.ALIGNMENT	MA	MEAS.	-DO-	-DO-	-DO-	Log Book	2	-	-	
		2.WORKMANSHIP	MA	VISUAL	-DO-	-DO-	-DO-	Log Book	2	-	-	
		3.AXIAL PLAY	MA	MEAS.	-DO-	-DO-	-DO-	Log Book	2	-	1	
		4.DIMENSIONS	MA	-DO-	-DO-	MFG.DRG./ MFG SPEC.	MFG. DRG/ RELEVANT IS	Log Book	2	-	-	
		5.CORRECTNESS, COMPLETENESS TERMINATIONS/ MARKING/ COLOUR CODE	MA	VISUAL	100%	MFG SPEC. RELEVANT IS	MFG SPEC. RELEVANT IS	Log Book	2	-	-	
		6. RTD, BTD & SPACE HEATER MOUNTING.	MA	VISUAL	100%	MFG SPEC. RELEVANT IS	MFG SPEC. RELEVANT IS	Log Book	2	-	1	
BHEL			PARTICULARS		BIDDER/VENDOR							
			NAME									
			SIGNATURE									
			DATE					BIDDER'S/VENDORS COMPANY SEAL				

THIS IS A PART OF TECHNICAL SPECIFICATION FOR OZONE GENERATION PLANT  
(TECHNICAL SPECIFICATION NUMBER: PE-TS-367-174-14000A-A001 REV 01)

SL. NO.	COMPONENT/OPERATION	CHARACTERISTIC CHECK	CUSTOMER			PROJECT TITLE			SPECIFICATION NUMBER			
												BIDDER/VENDOR SYSTEM
SHEET 8 OF 9												
1	2	3	4	5	6	7	8	9	SECTION			REMARKS
									P	W	V	
VOLUME III												
3.0	TESTS	1. TYPE TESTS INCLUDING SPECIAL TESTS AS PER BHEL SPEC.	MA	ELECT. TEST	1/TYPE/SIZE	IS-325/ BHEL SPEC./ DATA SHEET	IS-325/ BHEL SPEC./ DATA SHEET	TEST REPORT	2	1*	1	NOTE - 1
		2. ROUTINE TESTS INCLUDING SPECIAL TEST AS PER BHEL SPEC.	MA	-DO-	100%	-DO-	-DO-	-DO-	2	1*	1	NOTE - 2
		3. VIBRATION & NOISE LEVEL	MA	-DO-	100%	IS-12075 & IS-12065	IS-12075 & IS-12065	-DO-	2	1*	1	NOTE - 2
		4. OVERALL DIMENSIONS AND ORIENTATION	MA	MEASUREMENT & VISUAL	100%	APPROVED DRG/DATA SHEET	APPROVED DRG/DATA SHEET & RELEVANT IS	INSPC. REPORT	2	1	-	
		5. DEGREE OF PROTECTION	MA	ELECT. & MECH. TEST	1/TYPE/SIZE	RELEVANT IS	BHEL SPEC. AND DATA SHEET	TC	2	-	1	TC FROM AN INDEPENDENT LABORATORY, REFER NOTE-3
		6. MEASUREMENT OF RESISTANCE OF RTD & BTD	MA	-DO-	100%	-DO-	-DO-	-DO-	2	1*	1	NOTE - 2
		7. MEASUREMENT OF RESISTANCE, IR OF SPACE HEATER	MA	-DO-	100%	-DO-	-DO-	-DO-	2	1*	1	NOTE - 2
		8. NAMEPLATE DETAILS	MA	VISUAL	100%	IS-325 & DATA SHEET	IS-325 & DATA SHEET	INSPC. REPORT	2	1*	1	NOTE - 2
		9. EXPLOSION FLAME PROOF NESS (IF SPECIFIED)	MA	EXPLOSION FLAME PROOF TEST	1/TYPE	IS-3682 IS-8239 IS-8240	IS-3682 IS-8239 IS-8240	TC	2	-	1	TC FROM AN INDEPENDENT LABORATORY, REFER NOTE-3
		10. PAINT SHADE, THICKNESS & FINISH	MA	VISUAL & MEASUREMENT BY ELKOMETER	SAMPLE	BHEL SPEC. & DATA SHEET	BHEL SPEC. & DATA SHEET	TC	2	1*	1	SAMPLING PLAN TO BE DECIDED BY INSPECTION AGENCY NOTE - 2
BHEL			PARTICULARS			BIDDER/VENDOR						
			NAME									
			SIGNATURE									
			DATE						BIDDER'S/VENDORS COMPANY SEAL			

THIS IS A PART OF TECHNICAL SPECIFICATION FOR OZONE GENERATION PLANT  
(TECHNICAL SPECIFICATION NUMBER: PE-TS-367-174-14000A-A001 REV 01)

		<b>QUALITY PLAN</b>			CUSTOMER			PROJECT TITLE			SPECIFICATION NUMBER :	
		SHEET 9 OF 9			BIDDER/VENDOR SYSTEM			QUALITY PLAN NUMBER PED-506-00-Q-007, REV-03			SPECIFICATION TITLE	
					ITEM AC ELECT. MOTORS 55 KW & ABOVE (LV & MV)			SECTION		VOLUME III		
SL. NO.	COMPONENT/OPERATION	CHARACTERISTIC CHECK	CAT.	TYPE/METHOD OF CHECK	EXTENT OF CHECK	REFERENCE DOCUMENT	ACCEPTANCE NORM	FORMAT OF RECORD	P	W	V	REMARKS
1	2	3	4	5	6	7	8	9	10	11		
<p>NOTES:</p> <ol style="list-style-type: none"> <li>1 DEPENDING UPON THE SIZE AND CRITICALLY, WITNESSING BY BHEL SHALL BE DECIDED.</li> <li>2 ROUTINE TESTS ON 100% MOTORS SHALL BE DONE BY THE VENDOR. HOWEVER, BHEL SHALL WITNESS ROUTINE TESTS ON RANDOM SAMPLES. THE SAMPLING PLAN SHALL BE MUTUALLY AGREED UPON.</li> <li>3 IN CASE TEST CERTIFICATES FOR THESE TESTS ON SIMILAR TYPE, SIZE AND DESIGN OF MOTOR FROM INDEPENDENT LABORATORY ARE AVAILABLE, THESE TEST MAY NOT BE REPEATED.</li> <li>4 WHEREVER CUSTOMER IS INVOLVED IN INSPECTION, AGENCY (1) SHALL MEAN BHEL AND CUSTOMERS BOTH TOGETHER.</li> </ol> <p><u>Legends for Inspection agency</u></p> <ol style="list-style-type: none"> <li>1. BHEL/CUSTOMER</li> <li>2. VENDOR (MOTOR MANUFACTURER)</li> <li>3. SUB-VENDOR (RAW MATERIAL/COMPONENTS SUPPLIER)</li> </ol> <p>P. PERFORM W. WITNESS V. VERIFY</p>												
BHEL			PARTICULARS			BIDDER/VENDOR						
			NAME									
			SIGNATURE									
			DATE						BIDDER'S/VENDORS COMPANY SEAL			

THIS IS A PART OF TECHNICAL SPECIFICATION FOR OZONE GENERATION PLANT  
(TECHNICAL SPECIFICATION NUMBER: PE-TS-367-174-14000A-A001 REV 01)

		QUALITY PLAN		CUSTOMER :			PROJECT			SPECIFICATION :			
				BIDDER/ VENDOR			TITLE			NUMBER :			
SHEET 1 OF 2		SYSTEM			ITEM AC ELECT. MOTORS BELOW 55KW (LV)			SECTION			VOLUME III		
SL. NO.	COMPONENT/OPERATION	CHARACTERISTICS CHECK	CAT.	TYPE/ METHOD OF CHECK	EXTENT OF CHECK	REFERENCE DOCUMENT	ACCEPTANCE NORM	FORMAT OF RECORD	AGENCY			REMARKS	
1	2	3	4	5	6	7	8	9	P	W	V	11	
1.0	ASSEMBLY	1.WORKMANSHIP 2.DIMENSIONS 3.CORRECTNESS COMPLETENESS TERMINATIONS/ MARKING/COLOUR CODE	MA MA MA	VISUAL -DO- VISUAL	100% -DO- 100%	MANUF'S SPEC MFG. DRG./ MFG. SPEC. MFG.SPEC./ RELEVANT IS	MANUF'S SPEC MFG. DRG./ MFG. SPEC. MFG.SPEC. RELEVANT IS	-DO- -DO- -DO-	2 2 2	- - -	- - -		
2.0	PAINTING	1.SHADE	MA	VISUAL	SAMPLE	MANUFR'S SPEC/BHEL SPEC./RELEVANT STANDARD	BHEL SPEC. SAME AS COL.7	LOG BOOK	2	-	-		
3.0	TESTS	1.ROUTINE TEST INCLUDING SPECIAL TEST AS PER BHEL SPEC. 2.OVERALL DIMENSIONS & ORIENTATION	MA MA	-DO- MEASUREMENT & VISUAL	100% 100%	IS-325/ BHEL SPEC./ DATA SHEET APPROVED DRG/DATA SHEET	SAME AS COL.7 APPROVED DRG/DATA SHEET & RELEVANT IS	TEST REPORT INSPN. REPORT	2 2	1 1	- -	NOTE -1 & NOTE-3 NOTE -1 & NOTE-3	
BHEL			PARTICULARS			BIDDER/VENDOR							
			NAME										
			SIGNATURE										

THIS IS A PART OF TECHNICAL SPECIFICATION FOR OZONE GENERATION PLANT  
(TECHNICAL SPECIFICATION NUMBER: PE-TS-367-174-14000A-A001 REV 01)

	<b>QUALITY PLAN</b>		CUSTOMER :			PROJECT			SPECIFICATION :			
	SHEET 2 OF 2		BIDDER/ VENDOR SYSTEM			TITLE QUALITY PLAN NUMBER PED-506-00-Q-006, REV-01			NUMBER : SPECIFICATION : TITLE :			
SL. NO.	COMPONENT/OPERATION	CHARACTERISTICS CHECK	CAT.	TYPE/ METHOD OF CHECK	EXTENT OF CHECK	REFERENCE DOCUMENT	ACCEPTANCE NORM	FORMAT OF RECORD	SECTION			REMARKS
									P	W	V	
1	2	3	4	5	6	7	8	9	10			11
		3.NAMEPLATE DETAILS	MA	VISUAL	100%	IS-325 & DATA SHEET	IS-325 & DATA SHEET	INSPN. REPORT	2	1	-	
<p>NOTES:</p> <p>1 ROUTINE TESTS ON 100% MOTORS SHALL BE DONE BY THE VENDOR. HOWEVER, BHEL SHALL WITNESS ROUTINE TESTS ON RANDOM SAMPLES. THE SAMPLING PLAN SHALL BE MUTUALLY AGREED UPON</p> <p>2 WHERE EVER CUSTOMER IS INVOLVED IN INSPECTION, (1) SHALL MEAN BHEL AND CUSTOMERS BOTH TOGETHER.</p> <p>3 FOR EXHAUST/VENTILATION FAN MOTORS OF RATING UPTO 1.5KW , ONLY ROUTINE TEST CERTIFICATES SHALL BE FURNISHED FOR SCRUTINY.</p> <p><u>Legends for inspection agency</u></p> <p>1. BHEL/CUSTOMER 2. VENDOR (MOTOR MANUFACTURER) 3. SUB-VENDOR (RAW MATERIAL/COMPONENTS SUPPLIER)</p> <p>P. PERFORM W. WITNESS V. VERIFY</p>												
BHEL			PARTICULARS			BIDDER/VENDOR						
			NAME									
			SIGNATURE									
			DATE						BIDDER'S/VENDORS COMPANY SEAL			



**TITLE:**  
**TECHNICAL SPECIFICATION FOR  
OZONE GENERATION PLANT**  
**1X700 MW BELLARY THERMAL POWER  
STATION UNIT NO. 3, STAGE-3**

BHEL DOCUMENTS NO.: PE-TS-367-174-14000A-A001

VOLUME **II-B**

SECTION -C3

REV. NO. 01

DATE: 24/02/2014

### **SECTION C3: SPECIFIC TECHNICAL REQUIREMENTS FOR C&I**

## **SCOPE OF C&I FOR OZONE GENERATION PLANT**

1. The controls for Ozone generation plant/Electric breaker control shall be realized in PLC based control system. PLC based control system as defined in the enclosed specification and datasheets in the bidder's scope. The PLC system shall be comprised of:
  - i. PLC based control panel
  - ii. UPS power supply
  - iii. Operator interface (CRT), keyboard, mouse and OWS along with required furniture.
  - iv. Laser printer
  - v. PLC based annunciation system
2. The requirements given below are to be read in conjunction with detailed Technical specification & data sheets-A, B & C enclosed elsewhere in the specification. Further in case of any discrepancy in the requirement within the same section noted by the bidder in the specification, the same will be brought to the notice of BHEL in the form of pre-bid clarification, the more stringent requirement as per interpretation of customer/BHEL shall prevail without any commercial implication.
3. PLC based control system shall be provided with hot redundant processors. The Switch over from one processor to another processor shall be bumping less and the switch over time shall be within 50 msec. The processor shall be of 32 bits minimum.
4. Plant schematic for monitoring & operation shall be available on OWS, bidder to further submit list of important signal along with applicable schematic for monitoring in DCS.
5. The PLC based control system shall include all Primary and Secondary Instruments, Local control panels. All instruments required for the package shall be supplied, mounted on the gauge board racks, along with accessories like impulse pipe, fittings & valve manifolds etc.
6. PLC shall have facility to synchronize its time with BHEL supplied GPS. Necessary hardware (IRIG-B) /software for same at PLC end shall be provided by vendor.
7. PLC shall be connected to DCS through OFC with MODBUS Protocol for monitoring.
8. Vendor shall provide at least 20% or minimum one no. spare channels as hot-on-rail spares in each configured cards/modules. In addition to this 10% or minimum one no. extra assigned complete spare cards mounted on rails in sub-racks for each type of I/O modules shall also to be provided.
9. All bidirectional drives are with integral starter, typical Hook-up diagram of drives is attached for reference.
10. Bidder to provide redundant UPS (having necessary redundant power packs for PLC panel, PC, OWS, printer etc,) battery charger, switches & battery bank (lead Acid PLANTE type) for minimum 60 minute back up at 100 % load.
11. Soft link communication between PLC & DDCMIS shall be redundant Bi-directional OPC link. Bidder shall include required hardware and software. Communication protocol between PLC & DDCMIS shall be TCP/IP Ethernet & the maximum communication time for receipt of signal at DDCMIS end should not exceed 2 seconds. Necessary patch chords/converters, LIU at PLC end shall be under bidder's scope.
12. Bidder shall provide LPB station for start/stop & open/close shall be provided for testing & maintenance facility.
13. Connected data cable for PLC to remote I/O panels shall be through redundant cable/optic fibre with redundant I/O.

14. Bidder to include field instrumentation and field junction box (JB's) in his scope. All instruments/Drives shall be terminated on JB/Panel in field & instrument/Drives & JB/Panel & connecting Instrument & control cable is in bidder scope.
15. Bidder shall include 10% or 1 No. (whichever is higher) each type of module, which shall include controller card, communication card, I/O card, Power supply card/unit, relays, push button, lamps etc.
16. Bidder shall maintain redundancy in all the I/O's.
17. Bidder shall include measurement and control instruments of transmitters only. No switches shall be considered. All the control measurement and analysers and interlocks shall have redundant sensors.
18. All the valves corresponding under sequence shall be automatic valves.
19. VMS to be included in bidder's scope for HT drives, if applicable.



**TITLE:**  
**TECHNICAL SPECIFICATION FOR  
OZONE GENERATION PLANT**  
**1X700 MW BELLARY THERMAL POWER  
STATION UNIT NO. 3, STAGE-3**

BHEL DOCUMENTS NO.: PE-TS-367-174-14000A-A001

VOLUME **II-B**

SECTION -C3

REV. NO. 01

DATE: 24/02/2014

## PLC SYSTEM CONFIGURATION DIAGRAM

THIS IS A PART OF TECHNICAL SPECIFICATION FOR OZONE GENERATION PLANT  
(TECHNICAL SPECIFICATION NUMBER: PE-TS-367-174-14000A-A001 REV 01)

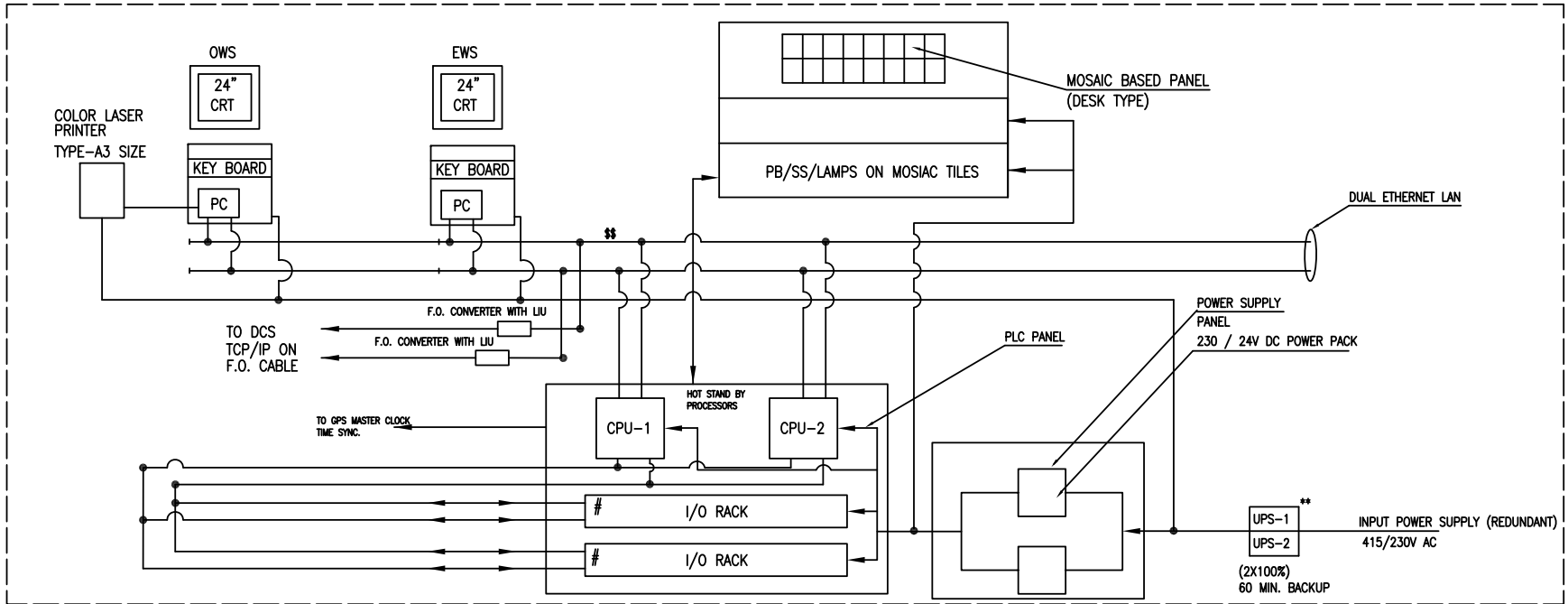

Notes:

- # : Redundancy to be provided for all the I/O's.
  - \*\* : For details kindly refer UPS scheme included in C&I Specification.
  - \$\$ Redundant Ethernet Switches to be provided to maintain overall Network redundancy at all levels.
- All the items shown here are in bidder's scope.

JOB No. : 367		<b>KARNATAKA POWER CORPORATION LTD.</b>	
STATUS: CONTRACT		<b>BELLARY TPS UNIT#3, 1 X 700 MW</b>	
DISTRIBUTION		BHARAT HEAVY ELECTRICALS LTD POWER SECTOR PROJECT ENGINEERING MANAGEMENT NOIDA	
TO		TITLE <b>SYSTEM CONFIGURATION DIAGRAM FOR OZONE GENERATION PLANT</b>	
REV	DATE 20.09.2012	DEPT.	DRAWING No.
01		SIGN	PE-DG-367-174-14000A-A002
		DATE	Page 75 of 217
			SHEET OF 1 REV 00



**TITLE:**  
**TECHNICAL SPECIFICATION FOR  
OZONE GENERATION PLANT**  
**1X700 MW BELLARY THERMAL POWER  
STATION UNIT NO. 3, STAGE-3**

BHEL DOCUMENTS NO.: PE-TS-367-174-14000A-A001

VOLUME **II-B**

SECTION -C3

REV. NO. 01

DATE: 24/02/2014

**QUALITY PLAN FOR PLC**



## STANDARD QUALITY PLAN FOR PROGRAMMABLE LOGIC CONTROLLER

QUALITY PLAN NO.: <b>PE-QP-999-145-I036</b>	
VOLUME	IIB
SECTION	C3
REV. NO.	01
SHEET	1 OF 8

Sl. No.	Component / operation	Characteristics Checked	* Category	Type/Method of Check	Extent of Check	Reference documents	Acceptance Norms	Format of Records	Agency <sup>§</sup>			Remarks
									P	W	V	
<b>1.0</b>	<b>Materials /Components</b>											
1.1	Panels & Control Desks	Physical Inspection for Dimensions, Painting, Cutouts, Lifting / Locking Arrangements, Components, Drawing Pocket, Mounting accessories, Plinth & AV Pads, Cable Gland Plates, Hardwares, Hinges, Louvers & Filters, Fans & Panel Lamps	MA	Visual	100%	Contract specifications, Approved GA Drawings, BOQ	As per ref documents. No physical damage.	BHEL Quality Inspection Report.	3/2	2	1	
1.2	Power Supply/Packs, Battery & Battery charger, Transformer, UPS.	Physical Inspection Physical Damages Dimensions Mounting Accessories	MA	Visual	100%	Contract specifications, BOQ.	As per reference documents, Test Report	BHEL Quality Inspection Report.	3/2	2	1	
1.3	Indicating Lamp, Annunciator, Meters, Transducers, Signal Converters, Instruments, Single Loop Controllers	Physical Verification Physical Damages Dimensions Accessories	MA	Visual	100%	Contract specifications, BOQ.	As per ref documents No physical damage. Test/ Calibration report.	BHEL Quality Inspection Report	3/2	2	1	
1.4	PLC processors, I/O modules, Power Supply modules, Communication modules, Mounting Racks, Ethernet	Physical Inspection <ul style="list-style-type: none"> <li>• Identification Labels</li> <li>• Physical Damages</li> <li>• Quantity</li> <li>• Spare Capacity</li> </ul>	MA	Visual	100%	Product Catalogue, Data sheets, Approved Configuration diagram, BOQ	As per ref documents. Test Certificates	BHEL Quality Inspection Report.	3/2	2	1	

LEGEND:	* CR - Critical characteristics	§ P - Agency Performing the Test.	1 - BHEL
	MA - Major characteristics	W - Agency Witnessing the Test.	2 - Vendor
	MI - Minor characteristics	V - Agency Verifying the Test.	3 - Sub-vendor

 PEM :: C&I	<b>STANDARD QUALITY PLAN FOR PROGRAMMABLE LOGIC CONTROLLER</b>							QUALITY PLAN NO.: <b>PE-QP-999-145-I036</b>				
								VOLUME	IIB			
								SECTION	C3			
								REV. NO.	01			
								SHEET	2	OF	8	
SI. No.	Component / operation	Characteristics Checked	* Category	Type/Method of Check	Extent of Check	Reference documents	Acceptance Norms	Format of Records	Agency <sup>\$</sup>			Remarks
									P	W	V	
1.5	CPU, Monitor, Keyboard, Mouse, CD Drives, Printers, OS, System Software, Engineering software in the form of Licensed CD.	Physical Inspection Identification Labels, <a href="#">Tech. Specification</a> Physical Damages Accessories Installation arrangements for Computers & Printers	MA	Visual	100%	Contract specifications, Product Catalogue, Approved GA / Configuration drawing, BOQ.	As per reference documents.	BHEL Quality Inspection Report.	3/2	2	1	

LEGEND: * CR - Critical characteristics MA - Major characteristics MI - Minor characteristics	<sup>\$</sup> P - Agency Performing the Test. W - Agency Witnessing the Test. V - Agency Verifying the Test.	1 - BHEL 2 - Vendor 3 - Sub-vendor
---	--	--



## STANDARD QUALITY PLAN FOR PROGRAMMABLE LOGIC CONTROLLER

QUALITY PLAN NO.: **PE-QP-999-145-I036**

VOLUME IIB

SECTION C3

REV. NO. 01

SHEET 3 OF 8

Sl. No.	Component / operation	Characteristics Checked	* Category	Type/Method of Check	Extent of Check	Reference documents	Acceptance Norms	Format of Records	Agency §			Remarks
									P	W	V	
<b>2.0</b>	<b>Assembly</b>											
2.1	Functional Test for HMI/OVS devices such as Monitors, Keyboards, Mouse, Printers etc.	Operation	MA	Functional	100%	Approved Configuration Diagram & BOQ and FAT	Correct Operation of interconnected Devices of HMI system.	BHEL Quality Inspection Report.	2	1	1	
2.2	Hardware Functional Verification.	Physical arrangement, Wiring check & labeling, Continuity Checking, IR & HV test	MA	Visual/ Electrical	100%	Approved GA Drawing, Panel Wiring Diagram, IR & HV as per relevant International standard	Test Certification	BHEL Quality Inspection Report.	2	2	1	
2.3	Powering Up	Healthiness of all the modules/equipment, associated with Powering of PLC system	MA	Visual /Electrical	100%	Approved power supply scheme	All equipment to be healthy on power ON	BHEL Quality Inspection Report.	2	1	1	
2.4	Burn in test for PLC modules	Healthiness of PLC modules on Continuous Energisation, Temperature maintenance	MA	Visual/ Electrical	100%	FAT Procedure	Test certification as per FAT	BHEL Quality Inspection Report.	2	2	1	

LEGEND: \* CR - Critical characteristics  
MA - Major characteristics  
MI - Minor characteristics

§ P - Agency Performing the Test.  
W - Agency Witnessing the Test.  
V - Agency Verifying the Test.

1 - BHEL  
2 - Vendor  
3 - Sub-vendor



PEM :: C&I

## STANDARD QUALITY PLAN FOR PROGRAMMABLE LOGIC CONTROLLER

QUALITY PLAN NO.: <b>PE-QP-999-145-I036</b>	
VOLUME	IIB
SECTION	C3
REV. NO.	01
SHEET	4 OF 8

Sl. No.	Component / operation	Characteristics Checked	* Category	Type/Method of Check	Extent of Check	Reference documents	Acceptance Norms	Format of Records	Agency <sup>§</sup>			Remarks
									P	W	V	
<b>3.0</b>	<b>Factory Acceptance Test (FAT)</b>											
3.1	Input Output Functional Verification	I/O configuration, I/O operation	MA	Visual/Electrical	100%	FAT Procedure	AS per FAT	BHEL Quality Inspection Report.	2	1	1	
3.2	Processor Verification	Processor configuration, Powering up, standby operation ( as applicable) and Loading	MA	Visual	100%	FAT Procedure	AS per FAT	BHEL Quality Inspection Report.	2	1	1	
3.3	Power Supply Module Verification	Redundancy Operation	MA	Electrical	100%	FAT Procedure	AS per FAT	BHEL Quality Inspection Report.	2	1	1	
3.4	Communication System Verification	Redundancy operation of Communication System, Measurement of Response Time, Communication with third party system	MA	Electrical	100%	FAT Procedure	AS per FAT	BHEL Quality Inspection Report.	2	1	1	
3.5	Diagnostic Verification	Self Diagnostic features of PLC system	MA	Visual	100%	FAT Procedure	AS per FAT	BHEL Quality Inspection Report.	2	1	1	
3.6	Control Panel/Desk Verification	Operation of PLC driven annunciation system, Mosaic, Push buttons & selector switches, Indicating lamps	MA	Visual	100%	FAT Procedure	AS per FAT	BHEL Quality Inspection Report.	2	1	1	
3.7	Software Verification	(i) Control Logics (ii) Engineering Features (iii) HMI Features	MA	Visual	100%	FAT Procedure	AS per FAT	BHEL Quality Inspection Report.	2	1	1	

<b>LEGEND:</b> * CR - Critical characteristics MA - Major characteristics MI - Minor characteristics	<sup>§</sup> P - Agency Performing the Test. W - Agency Witnessing the Test. V - Agency Verifying the Test.	1 - BHEL 2 - Vendor 3 - Sub-vendor
--	---	--

**STANDARD QUALITY PLAN  
FOR  
PROGRAMMABLE LOGIC CONTROLLER**

QUALITY PLAN NO.: <b>PE-QP-999-145-I036</b>			
VOLUME IIB			
SECTION C3			
REV. NO. <b>01</b>			
SHEET	5	OF	8

THIS IS A PART OF TECHNICAL SPECIFICATION FOR OZONE GENERATION PLANT  
(TECHNICAL SPECIFICATION NUMBER: PE-TS-367-174-14000A-A001 REV 01)

**FACTORY ACCEPTANCE TEST (FAT) PROCEDURE**

This document covers procedure to conduct/witness PLC system functional tests in order to demonstrate conformity to purchase specifications and related engineering documents. The test shall be conducted at the system suppliers works. The system supplier shall conduct all functional tests before commencing FAT and test results shall be made available during FAT. Vendor must furnish following relevant drawings, duly approved by BHEL Engineering, for reference during FAT.

- a) Technical Specification of PLC.
- b) PLC System Configuration
- c) General Assembly Drawings.
- d) Panel Wiring Diagrams.
- e) Bill of Quantity for PLC System.
- f) Logic Diagram.
- g) HMI Schematics.
- h) Input / Output List.

Further the vendor shall furnish applicable product specification, datasheets, catalogues, test-certificates, and internal inspection records to enable FAT. Vendor shall also submit, [to the inspecting agency](#), his standard test procedure, for clauses given below; where vendor's standard practice has been referred.

**APPLICABLE TEST PROCEDURE:**

**1. Input/Output Functional Verification.**

Check for correctness of addressing of racks, slots and I/O modules as per applicable PLC configuration diagram. Appropriate signal generators shall be used to simulate Inputs and outputs to check operation and SCAN time. [Check online replacement of cards, processors, power supply etc.](#)

**2. Processor Verification**

PLC Configuration drawing to be referred for ascertaining

- i) Redundancy

**STANDARD QUALITY PLAN  
FOR  
PROGRAMMABLE LOGIC CONTROLLER**

QUALITY PLAN NO.:	PE-QP-999-145-I036
VOLUME	IIB
SECTION	C3
REV. NO.	01
SHEET	6 OF 8

ii) Type (Hot or Cold)

Both the processors are to be checked for healthiness in case of redundant configuration as per vendor's standard practice. In case of hot redundancy, switchover of control from primary processor to standby processor shall be demonstrated for uninterrupted control and data processing as per vendor's standard practice. Switchover shall be witnessed, by manual power off or resetting the Primary CPU or simulating failure of primary processor. Checking should be by witnessing the lighting up of Processor's LEDs as per manufacturer's product standard.

Vendor shall demonstrate, as per Vendor's standard practice, adequate Loading (Spare Capacity) of Processors, as mentioned in contract specs. This shall be done, by simulating worst load operation of fully integrated PLC system.

**3. Power Supply Module Verification**

Check if PSM is in redundant mode as per specification. Check the healthiness of power supply from both the modules' lamp indication/measurement. Simulate failure of one PSM and verify that standby PSM has taken over without any interruption.

**4. Communication System Verification**

Communication system has to be in line with approved PLC Configuration Diagram. Verify that both the communication buses are intact and connected. Communication between PLC processors, I/O rack, OWS etc. is to be checked through simulation of input data. Simulate the bus failure by disconnection of working bus. Check that the communication continues without interruption or loss of data.

Following response times are to be demonstrated as per vendor's standard practice for conformance to contract specifications:

1. Screen update time
2. I/O scan time
3. SOE resolution time
4. Data transfer time with third party system using Communication Protocol as per Contract specification and as per quantum of data as per approved signal exchange list.

**5. Diagnostic Verification**

Product Catalogue/Literature shall be referred for checking of all diagnostic features. Hardware failure to be simulated by removing an I/O

**STANDARD QUALITY PLAN  
FOR  
PROGRAMMABLE LOGIC CONTROLLER**

QUALITY PLAN NO.:	PE-QP-999-145-I036		
VOLUME	IIB		
SECTION	C3		
REV. NO.	01		
SHEET	7	OF	8

**6. Control Panel /Desk Verification**

- i) PLC driven annunciation system should be checked by alarm signal simulation.
- ii) Push Button and selector switch operation should be checked by verification of corresponding change of status of Data Base point.
- iii) Indicating lamp / MIMIC should be checked by corresponding Data Base point simulation.

**7. Software Verification**

- i). Control Logics:- Software switches, lamps and Analog sources shall be used for simulation of field conditions .Control logics shall be checked for its correct functionality as per approved logic schemes
- ii). Engineering features:-
  - a) Online changing of parameters, set points.
  - b) Online modification in Control Logic Diagrams.
  - c) Online configuration of Graphics, Trends, Logs, HSR.
- iii). HMI features:-  
Check for configuration & operation of Graphics, Trends, Logs, HSR and Alarms, in the form of Displays and Printouts, by simulation of Inputs as per approved documents.

**8. Burn in Elevated Temperature test**

Electronic equipments shall be subjected to Burn in elevated temperature test as per the procedure detailed below:

- a) (i) PLC modules are kept at 50 Deg c under continuous energized condition for 48 hours.

**STANDARD QUALITY PLAN  
FOR  
PROGRAMMABLE LOGIC CONTROLLER**

QUALITY PLAN NO.: <b>PE-QP-999-145-1036</b>
VOLUME IIB
SECTION C3
REV. NO. 01
SHEET 8 OF 8

ii) 48 hours test period shall be divided into 4 equal time segment of 12 hours duration each. For every 12 hours duration segment, after lapse of first 11 hours 110% of nominal voltage shall be applied to the panel under test for a period of 30 minutes followed by application of 90% of nominal voltage for the next 30 minutes.

b) Assembled Panels with complete wiring shall be kept under continuous energized condition for 120 hours at ambient temperature. Temperature rise in panels should be below 10 Deg C above ambient.



**TITLE:**  
**TECHNICAL SPECIFICATION FOR  
OZONE GENERATION PLANT**  
**1X700 MW BELLARY THERMAL POWER  
STATION UNIT NO. 3, STAGE-3**

BHEL DOCUMENTS NO.: PE-TS-367-174-14000A-A001

VOLUME **II-B**

SECTION -C3

REV. NO. 01

DATE: 24/02/2014

**QUALITY PLAN FOR C&I ITEMS**



PEM :: C&I

## STANDARD QUALITY PLAN FOR PRESSURE AND DIFFERENTIAL PRESSURE GAUGES

QUALITY PLAN NO.: PE-QP-999-145-I026	
VOLUME	IIB
SECTION	C3
REV. NO.	01
SHEET	1 OF 2

Sl. No.	Component / operation	Characteristics Checked	* Category	Type/Method of Check	Extent of Check	Reference documents	Acceptance Norms	Format of Records	Agency <sup>\$</sup>			Remarks
									P	W	V	
1.0	<b>Material / Components</b>											
1.1	Casing, Bourdon tube and Movement	1. Chemical composition	MA	Chemical Test	One Sample from each lot	Approved drg. / data sheet / BHEL Spec.	Relevant raw material std.	Test Certificate	3/2	---	2,1#	# Compliance certificate to be verified.
		2. Workmanship, finish and dimensions	MA	Visual, Measurement	100%	Approved drg. / data sheet / BHEL Spec.	Approved drg. / data sheet / BHEL Spec.	Inspection Report / Log Book	3/2	---	2,1#	
1.2	Switch <sup>⊕</sup>	Contact type & number	MA	Visual	100%	Approved drg. / data sheet / BHEL Spec.	Approved drg. / data sheet / BHEL Spec.	Test Certificate/ Inspection Report	3	---	2,1#	⊕Applicable for gauge with switch device
2.0	<b>Assembly</b>	1. Marking – Tag No., Model, Range	MA	Visual	100%	- do -	- do -	Inspection Report	2	1	---	
		2. Workmanship	MA	Visual	100%	- do -	- do -	- do -	2	1	---	
		3. Dial size, scale graduation	MA	Visual	100%	- do -	- do -	- do -	2	1	---	
		4. End connections	MA	Measurement	100%	- do -	- do -	- do -	2	1**	1	**10% of total quantity with minimum of 2 piece / type & size
		⊕5. Switch – contact type & nos.	MA	Visual	100%	- do -	- do -	Inspection Report	2	1	---	
3.0	<b>Routine Test</b>	1. Calibration, accuracy, Hysteresis, overload, set point adjustment <sup>⊕</sup> / repeatability	CR	Measurement	100%	- do -	- do -	- do -	2	1**	1	

LEGEND: \* CR - Critical characteristics  
MA - Major characteristics  
MI - Minor characteristics

<sup>\$</sup> P - Agency Performing the Test.  
W - Agency Witnessing the Test.  
V - Agency Verifying the Test.

1 - BHEL  
2 - Vendor  
3 - Sub-vendor



## STANDARD QUALITY PLAN FOR PRESSURE AND DIFFERENTIAL PRESSURE GAUGES

QUALITY PLAN NO.: PE-QP-999-145-I026

VOLUME IIB

SECTION C3

REV. NO. 01

SHEET 2 OF 2

Sl. No.	Component / operation	Characteristics Checked	* Category	Type/Method of Check	Extent of Check	Reference documents	Acceptance Norms	Format of Records	Agency <sup>\$</sup>			Remarks
									P	W	V	
		2. Hydraulic Test	CR	Measurement	100%	Approved drg. / data sheet / BHEL Spec.	No Leakage	Inspection Report	2	1**	1	
		⊕3. IR, HV	CR	Measurement	100%	Relevant standard	Relevant standard	- do -	2	1**	1	
4.0	Type Test	1. Enclosure Protection Class	CR	Verification	Each type	Approved drg. / data sheet / BHEL Spec.	Approved drg. / data sheet / BHEL Spec.	Test Certificate	2	---	1•	•Type Test Certificate to be verified
		2. Blow out disc	CR	Verification	Each type	- do -	- do -	- do -	2	---	2•	
		⊕3. Switch contact rating	CR	Verification	Each type	- do -	- do -	- do -	2	---	2•	
5.0	Painting	Shade & Finish	MA	Visual	100%	Approved drg. / data sheet / BHEL Spec. / Manufacturer's std.	Approved drg. / data sheet / BHEL Spec. / Manufacturer's std.	Inspection Report	2	---	2	
6.0	Packing	Soundness	MA	Visual	100%	- do -	- do -	- do -	2	---	---	

LEGEND: \* CR - Critical characteristics  
MA - Major characteristics  
MI - Minor characteristics

<sup>\$</sup> P - Agency Performing the Test.  
W - Agency Witnessing the Test.  
V - Agency Verifying the Test.

1 - BHEL  
2 - Vendor  
3 - Sub-vendor



PEM :: C&I

## STANDARD QUALITY PLAN FOR TEMPERATURE GAUGE AND THERMOWELL

QUALITY PLAN NO.: **PE-QP-999-145-I027**

VOLUME IIB

SECTION C3

REV. NO. **01**

SHEET 1 OF 4

Sl. No.	Component / operation	Characteristics Checked	* Category	Type/Method of Check	Extent of Check	Reference documents	Acceptance Norms	Format of Records	Agency <sup>§</sup>			Remarks
									P	W	V	
<b>1.0 Raw Material / Component</b>												
1.1	Capillary Bulb and Thermowell	1. Chemical composition	CR	Chemical analysis	one sample/lot	BHEL spec. / approved data sheet	Relevant raw material std.	Test report	3/2	---	2,1	Relevant compliance certificate to be verified by <b>BHEL</b>
		2. Marking,	MA	Visual	100%	BHEL spec. / Mfr. Standard	BHEL spec. / Mfr. Standard	Log Book	2	---	---	
		3. Dimensions	MA	Measurement	100%	BHEL spec. / approved doc	BHEL spec. / approved doc	Log Book	2	---	---	
1.2	Casing and Bezel	1. Material	MA	Chemical analysis	Sample	BHEL spec.	BHEL spec.	Test report	3/2	---	2,1	Relevant compliance certificate to be verified by <b>BHEL</b>
		2. Defects	MA	Visual	100%	Mfr. Standard	Mfr. Standard	Log Book	2	---	---	
		3. Dimension	MA	Measurement	Sample	BHEL spec. / approved doc.	BHEL spec. / approved doc.	Log Book	2	---	---	
		4. Threading	MA	Thread matching	100%	-----do-----	-----do-----	Log Book	2	---	---	
1.3	Dial	1. Size, range, scale length, least-count, spacing and graduation.	MA	Measurement and Visual	Sample	BHEL spec.	BHEL spec.	Log Book	2	---	---	
		2. Colour	MA	Visual	100%	BHEL spec.	BHEL spec.	Log Book	2	---	---	
		3. Resistance to dry heat and hot water	MA	Oven & Bath	Sample	Mfr. Standard	Mfr. Standard	Test report	3/2	---	---	

LEGEND: \* CR - Critical characteristics  
MA - Major characteristics  
MI - Minor characteristics

<sup>§</sup> P - Agency Performing the Test.  
W - Agency Witnessing the Test.  
V - Agency Verifying the Test.

1 - BHEL  
2 - Vendor  
3 - Sub-vendor



PEM :: C&I

## STANDARD QUALITY PLAN FOR TEMPERATURE GAUGE AND THERMOWELL

QUALITY PLAN NO.: <b>PE-QP-999-145-I027</b>	
VOLUME	IIB
SECTION	C3
REV. NO.	<b>01</b>
SHEET	2 OF 4

Sl. No.	Component / operation	Characteristics Checked	* Category	Type/Method of Check	Extent of Check	Reference documents	Acceptance Norms	Format of Records	Agency <sup>§</sup>			Remarks
									P	W	V	
1.4	Complete sensing element	1. Correct assembly and workmanship.	MA	Visual	100%	Mfr. Standard drawing	Mfr. Standard drawing	Log Book	2	---	---	
		2. Dimensions	MA	Measurement	100%	Mfr. Standard drawing	Mfr. Standard drawing	Log Book	2	---	---	
		3. Welding & other defects	MA	Visual	100%	Mfr. Standard	Mfr. Standard	Log Book	2	---	---	
1.5	Thermowell ⊕	1. Dimensions of wall thickness, concentricity of bore OD & Length.	MA	Measurement	100%	BHEL spec. / approved data sheet / Drg.	BHEL spec. / approved data sheet / Drg.	Log Book	2	1	1	BHEL to witness 10 % random samples.
		2. Leak Test	CR	Hyd. test at 1.5 times of design pressure.	100%	BHEL spec. / approved data sheet / Drg.	BHEL spec. / approved data sheet / Drg.	Inspection report	3/2	2,1	1	⊕ IBR cert. wherever specified to be verified.
		3. Threading	MA	Thread matching	100%	BHEL spec. / approved data sheet / Drg	BHEL spec. / approved data sheet / Drg	Inspection report	2	2,1	1	BHEL to witness 10% samples.
2.0	Final Inspection											
2.1	Assembly	1. Correct assembly, workmanship and finish	MA	Visual	100%	BHEL spec. / approved data sheet	BHEL spec. / approved data sheet	Inspection report	2	1	---	

LEGEND: \* CR - Critical characteristics  
MA - Major characteristics  
MI - Minor characteristics

<sup>§</sup> P - Agency Performing the Test.  
W - Agency Witnessing the Test.  
V - Agency Verifying the Test.

1 - BHEL  
2 - Vendor  
3 - Sub-vendor



PEM :: C&I

## STANDARD QUALITY PLAN FOR TEMPERATURE GAUGE AND THERMOWELL

QUALITY PLAN NO.: **PE-QP-999-145-I027**

VOLUME IIB

SECTION C3

REV. NO. **01**

SHEET 3 OF 4

Sl. No.	Component / operation	Characteristics Checked	* Category	Type/Method of Check	Extent of Check	Reference documents	Acceptance Norms	Format of Records	Agency <sup>§</sup>			Remarks
									P	W	V	
		2. Mounting and connection	MA	Visual ad measurement	100%	-----do-----	-----do-----	Inspection report	2	1	---	
		3. Dial Scale	MA	Visual	100%	-----do-----	-----do-----	Log Book	2	1	---	
		1. Cleanliness	MA	Visual	100%	-----do-----	Free from scratches, dirt etc.	Log Book	2	---	<b>2</b>	
		5. Marking (S.No., Tag No.)	MA	Visual	100%	BHEL spec. / approved data sheet	BHEL spec. / approved data sheet	Log Book	2	1	---	
2.2	Routine Test	1. Accuracy	MA	Measurement	100%	BHEL spec. / Approved data Sheet.	BHEL spec. / Approved data Sheet.	Test Report	2	1	1	BHEL to witness <b>10% random</b> Samples.
		2. Overload	CR	Measurement	10%	125% of FSD for range upto 400 Deg. C. 110% of FSD for range between 400 to 500 Deg. C. 100% of FSD for range above 500 Deg. C.	<b>No Damage</b>	Test Report	2	1	---	

LEGEND: \* CR - Critical characteristics  
MA - Major characteristics  
MI - Minor characteristics

<sup>§</sup> P - Agency Performing the Test.  
W - Agency Witnessing the Test.  
V - Agency Verifying the Test.

1 - BHEL  
2 - Vendor  
3 - Sub-vendor

 PEM :: C&I	<b>STANDARD QUALITY PLAN FOR TEMPERATURE GAUGE AND THERMOWELL</b>							QUALITY PLAN NO.: <b>PE-QP-999-145-I027</b>				
								VOLUME IIB				
								SECTION C3				
								REV. NO. <b>01</b>				
							SHEET 4 OF 4					
Sl. No.	Component / operation	Characteristics Checked	* Category	Type/Method of Check	Extent of Check	Reference documents	Acceptance Norms	Format of Records	Agency <sup>§</sup>			Remarks
									P	W	V	
		3. Response Time	MA	Measurement	10%	ASME PTC19.3	ASME PTC19.3	Test Report	2	1	1	BHEL to witness 10% random samples.
2.3	Type Test	1. Ambient temperature compensation 0-60 Deg. C	MA	Measurement	Sample	Bulb at constant temp. & case temp varied 0-60 Deg. C	No variation in measurement	Test Certificate	2	---	1	Existing test certificate (Not more than 5 year old) shall be furnished.
		2. Weather proofness	CR	Measurement	Sample	BHEL spec. / Approved data sheet.	BHEL spec. / Approved data sheet.	Test Certificate	3/2	---	1	---do---
3.0	Packing	Soundness of packing	MA	Visual	100%	BHEL Spec.	BHEL Spec.	Log Book	3/2	2	---	Refer Note-1

**Note: 1.** In the absence of BHEL specification for painting, vendor to obtain BHEL's approval on their painting specification / procedure.

LEGEND: * CR - Critical characteristics MA - Major characteristics MI - Minor characteristics	<sup>§</sup> P - Agency Performing the Test. W - Agency Witnessing the Test. V - Agency Verifying the Test.	1 - BHEL 2 - Vendor 3 - Sub-vendor
---	---	--

THIS IS A PART OF TECHNICAL SPECIFICATION FOR OZONE GENERATION PLANT  
(TECHNICAL SPECIFICATION NUMBER: PE-TS-367-174-14000A-A001 REV 01)

Sl. No.	Component / operation	Characteristics Checked	* Category	Type/Method of Check	Extent of Check	Reference documents	Acceptance Norms	Format of Records	Agency <sup>§</sup>			Remarks
									P	W	V	
 <b>STANDARD QUALITY PLAN FOR LOCAL CONTROL PANEL</b>									STD QUALITY PLAN NO.: <b>PE-QP-999-145-I056</b> VOLUME IIB SECTION C3 REV. NO. <b>01</b> SHEET 1 OF 7			
1.0	<b>INCOMING</b> Sheet Steel (CRCA & HR)	1. Chemical Composition 2. Bend Test 3. Surface finish 4. Waviness 5. Thickness 6. Mill marking	MA CR MA MA MA MA	Chemical analysis Mech. test Visual Visual Measurement Visual	Sample Sample 100% 100% 100% 100%	IS:1079 IS:513 IS:1079 IS:513 Factory Standard / Sample Factory Standard BHEL Spec. Factory Standard	IS:1079 IS:513 IS:1079 IS:513 Factory Standard / Sample No Waviness BHEL Spec. Factory Standard	Test Certificate Log Book Log Book Log Book Log Book Log Book	3 2 2 2 2 2	--- --- --- --- --- ---	2 --- --- --- --- 1	
2.0	Flats / Angles / Channels	1. Dimensions 2. Surface Defects 3. Straightness 4. Mill marking	MA MA MA MA	Measurement Visual Measurement Visual	Sample 100% 100% 100%	IS:2062 Factory Standard / Sample Factory Std. IS:2062	IS:2062 Factory Standard / Sample Factory Std. IS:2062	Log Book Log Book Log Book Log Book	2 2 2 2	--- --- --- ---	--- --- --- 1	
3.0	Cables / Wires	1. Visual / Surface defects 2. IR and HV	MA MA	Visual Electrical	100% 100%	BHEL Spec. and IS:1554 or IS:694 BHEL Spec. and IS:1554 or IS:694	BHEL Spec. and IS:1554 or IS:694 BHEL Spec. and IS:1554 or IS:694	Log Book Log Book	2 2	--- ---	--- ---	
<b>LEGEND:</b> * CR - Critical characteristics      § P - Agency Performing the Test.      1 - BHEL MA - Major characteristics                      W - Agency Witnessing the Test.                      2 - Vendor MI - Minor characteristics                        V - Agency Verifying the Test.                        3 - Sub-vendor												

Sl. No.	Component / operation	Characteristics Checked	* Category	Type/Method of Check	Extent of Check	Reference documents	Acceptance Norms	Format of Records	Agency <sup>§</sup>			Remarks
									P	W	V	
 <b>STANDARD QUALITY PLAN FOR LOCAL CONTROL PANEL</b>									STD QUALITY PLAN NO.: <b>PE-QP-999-145-I056</b> VOLUME IIB SECTION C3 REV. NO. <b>01</b> SHEET 2 OF 7			
		3. Conductor a) Resistance b) Size c) Sheet colour	MA MA MA	Electrical Measurement Visual	100% 100% 100%	BHEL Spec. and IS:1554 or IS:694	BHEL Spec. and IS:1554 or IS:694	Log Book	2	---	---	
		4. Type / Routine Test Certificates	MA	Verification	100%	BHEL Spec. and IS:1554 or IS:694	BHEL Spec. and IS:1554 or IS:694	Log Book	3	---	<b>2</b>	
4.0	Electrical Components like Annunciator Transformers Lamps Switches PBs Contactors Relays Timers Space Heaters Thermostat Indicating meters etc.	1. Verification at make and Type 2. Verification of Test Certificates 3. Operation / Functional check 4. I.R. 5. H.V. 6. Calibration 7. Pick up / Drop off Voltage	CR CR CR MA MA MA MA	Visual Scrutiny of Type / Routine T.Cs. Electrical Electrical Electrical Electrical	Sample 100% Sample+ 100% 100% 100% 100%	BHEL Spec. and BOM Relevant IS Relevant Indian Std & Catalogue Relevant Indian Std & Catalogue Relevant Indian Std & Catalogue Relevant Indian Std & Catalogue	BHEL Spec. and BOM Relevant IS Relevant Indian Std & Catalogue Relevant Indian Std & Catalogue Relevant Indian Std & Catalogue Relevant Indian Std & Catalogue	Log Book Log Book Log Book Log Book Log Book Log Book Log Book	2 2 2 2 2 2 2	--- --- --- --- --- --- ---	--- --- --- --- --- --- ---	+ for relay & contactors only @ for all components except relays & contactors.      <b>1</b>
LEGEND: * CR - Critical characteristics      § P - Agency Performing the Test.      1 - BHEL MA - Major characteristics            W - Agency Witnessing the Test.        2 - Vendor MI - Minor characteristics            V - Agency Verifying the Test.         3 - Sub-vendor												



PEM :: C&I

## STANDARD QUALITY PLAN FOR LOCAL CONTROL PANEL

STD QUALITY PLAN NO.: **PE-QP-999-145-I056**

VOLUME IIB

SECTION C3

REV. NO. **01**

SHEET 3 OF 7

Sl. No.	Component / operation	Characteristics Checked	* Category	Type/Method of Check	Extent of Check	Reference documents	Acceptance Norms	Format of Records	Agency <sup>§</sup>			Remarks
									P	W	V	
5.0	Misc. Components like <b>Gaskets, Terminal Blocks etc.</b>	1. Verification of Type / Make	MA	Visual	Sample	BHEL Spec. & Mfrs. Catalogue	BHEL Spec. & Mfrs. Catalogue	Log Book	2	---	---	
		2. Surface defects	MA	Visual	Sample	BHEL Spec. & Mfrs. Catalogue	BHEL Spec. & Mfrs. Catalogue	Log Book	2	---	---	
		3. IR / HV on Terminal Blocks	MA	Electrical	Sample	BHEL Spec. & Mfrs. Catalogue	BHEL Spec. & Mfrs. Catalogue	Log Book	2	---	---	
6.0	<b>IN PROCESS</b> Blanking / Bending / Forming	1. Dimensions	MI	Measurement	100%	Approved Mfr. drgs.	Approved Mfr. drgs.	Log Book	2	---	---	
		2. Surface defects after bending	MA	Visual	100%	<b>Factory Standard</b>	<b>Factory Standard</b>	Log Book	2	---	---	
7.0	Nibbling / Punching	1. Cutout Sizes	MI	Measurement	100%	Approved Mfr. drgs.	Approved Mfr. drgs.	Log Book	2	---	---	
		2. Deburring	MA	Visual	100%	Approved Mfr. drgs.	Approved Mfr. drgs.	Log Book	2	---	---	
8.0	<b>ASSEMBLY</b> Frame Assembly & Sheet fixing	1. Dimensions	MA	Measurement	100%	Approved drg. / Mfr. Standards	Approved drg. / Mfr. Standards	Log Book	2	---	2	
		2. Alignment	MA	Measurement	100%	Approved drg. / Mfr. Standards	Approved drg. / Mfr. Standards	Log Book	2	---	2	
		3. Welding Quality	MA	Visual	100%	Approved drg. / Mfr. Standards	Approved drg. / Mfr. Standards	Log Book	2	---	2	
		4. Surface defects	MA	Visual	100%	Approved drg. / Mfr. Standards	Approved drg. / Mfr. Standards	Log Book	2	---	2	

LEGEND: \* CR - Critical characteristics  
MA - Major characteristics  
MI - Minor characteristics

<sup>§</sup> P - Agency Performing the Test.  
W - Agency Witnessing the Test.  
V - Agency Verifying the Test.

1 - BHEL  
2 - Vendor  
3 - Sub-vendor

THIS IS A PART OF TECHNICAL SPECIFICATION FOR OZONE GENERATION PLANT  
(TECHNICAL SPECIFICATION NUMBER: PE-TS-367-174-14000A-A001 REV 01)

Sl. No.	Component / operation	Characteristics Checked	* Category	Type/Method of Check	Extent of Check	Reference documents	Acceptance Norms	Format of Records	Agency <sup>§</sup>			Remarks
									P	W	V	
		<b>STANDARD QUALITY PLAN FOR LOCAL CONTROL PANEL</b>						STD QUALITY PLAN NO.: <b>PE-QP-999-145-I056</b>				
								VOLUME		IIB		
								SECTION		C3		
								REV. NO.		01		DATE: 08.08.2008
								SHEET		4	OF	7
9.0	Pre-treatment and Painting	<b>1. Pretreatment Process</b>  2. Process parameters like bath temp. concentration etc.  3. Dipping / Removal Time  4. Surface quality after every dip  5. Primer after phosphating  6. Putty Application & Rubbing <b>after primer</b>  7. Paint first coat  8. Putty Application and Rubbing <b>after first coat of paint</b>  9. Paint second coat	MA  MA  MA  MA  MA  MA  MA  MA	Visual  Measurement  Measurement  Visual  Visual, Thickness  Visual  Visual, Thickness  Visual  Visual, Thickness, Scratch test Colour adhesion	100%  Periodic  100%  100%  100%  100%  100%	Factory Standard & IS: 6005  Factory Standard & IS: 6005  Factory Standard & IS: 6005  Factory Standard & IS: 6005  Factory Standard & IS: 6005  Factory Standard & IS: 6005  Factory Standard & IS: 6005  Factory Standard & IS: 6005	Factory Standard & IS: 6005  Factory Standard & IS: 6005  Factory Standard & IS: 6005  Factory Standard & IS: 6005  Factory Standard & IS: 6005  Factory Standard & IS: 6005  Factory Standard & IS: 6005	Log Book  Log Book  Log Book  Log Book  Log Book  Log Book  Log Book  Log Book	2  2  2  2  2  2  2  2	---  ---  ---  ---  ---  ---  ---	1  1  1  1  1  1	
LEGEND: * CR - Critical characteristics      § P - Agency Performing the Test.      1 - BHEL MA - Major characteristics            W - Agency Witnessing the Test.      2 - Vendor MI - Minor characteristics            V - Agency Verifying the Test.        3 - Sub-vendor												

Sl. No.	Component / operation	Characteristics Checked	* Category	Type/Method of Check	Extent of Check	Reference documents	Acceptance Norms	Format of Records	Agency <sup>\$</sup>			Remarks
									P	W	V	
 <b>STANDARD QUALITY PLAN FOR LOCAL CONTROL PANEL</b>									STD QUALITY PLAN NO.: <b>PE-QP-999-145-I056</b> VOLUME IIB SECTION C3 REV. NO. <b>01</b> SHEET 5 OF 7			
10.	Panel Wiring	1. Wiring Layout 2. Wiring Termination (Crimped Lugs) 3. Ferrule numbers 4. Colour of wiring 5. Size of <b>Conductor</b>	MA	Visual	100%	Approved drgs. & Specs.	Approved drgs. & Specs.	Log Book	2	---	---	
			MA	Visual	100%	Approved drgs. & Specs.	Approved drgs. & Specs.	Log Book	2	---	---	
			MA	Visual	100%	Approved drgs. & Specs.	Approved drgs. & Specs.	Log Book	2	---	---	
			MA	Visual	100%	Approved drgs. & Specs.	Approved drgs. & Specs.	Log Book	2	---	1	
			MA	<b>Measurement</b>	100%	Approved drgs. & Specs.	Approved drgs. & Specs.	Log Book	2	---	1	
11.	Component Mounting	1. <b>Correct components</b> 2. <b>Fixing</b>	MA	Visual	100%	Approved drgs., Specs. & BOM	Approved drgs., Specs. & BOM	Log Book	2	---	---	
			MA	Visual	100%	Approved drgs., Specs. & BOM	Approved drgs., Specs. & BOM	Log Book	2	---	---	
12.	<b>FINAL</b> Final Inspection	1. Workmanship 2. Component layout (neatness, accessibility & safety) Mounting / Proper fixing of all components 3. Components identification Marking / Name plates	MA	Visual	100%	<b>Factory Standard</b>	<b>Factory Standard</b>	<b>Inspection Report</b>	2	1	1	} At Random by BHEL, based on 100 % internal test reports by Mfr.
			MA	Visual	100%	<b>BHEL approved drg. / Spec.</b>	<b>BHEL approved drg. / Spec.</b>	<b>Inspection Report</b>	2	1	1	
			MA	Visual	100%	<b>BHEL approved drg. / Spec.</b>	<b>BHEL approved drg. / Spec.</b>	<b>Inspection Report</b>	2	1	1	

LEGEND: \* CR - Critical characteristics  
 MA - Major characteristics  
 MI - Minor characteristics

<sup>\$</sup> P - Agency Performing the Test.  
 W - Agency Witnessing the Test.  
 V - Agency Verifying the Test.

1 - BHEL  
 2 - Vendor  
 3 - Sub-vendor

 PEM :: C&I	<b>STANDARD QUALITY PLAN FOR LOCAL CONTROL PANEL</b>								STD QUALITY PLAN NO.: <b>PE-QP-999-145-I056</b>			
									VOLUME	IIB		
									SECTION	C3		
									REV. NO.	0 } }		
								SHEET	6	OF	7	
Sl. No.	Component / operation	Characteristics Checked	* Category	Type/Method of Check	Extent of Check	Reference documents	Acceptance Norms	Format of Records	Agency <sup>§</sup>			Remarks
									P	W	V	
		5. Dimensions	MA	Measurement	100%	BHEL approved drg. / Spec., BOM	BHEL approved drg. / Spec., BOM	Inspection Report	2	1	1	At Random by BHEL, based on 100 % internal test reports by Mfr.
		6. Door functioning	MA	Functional	100%	BHEL approved drg. / Spec.	BHEL approved drg. / Spec.	Inspection Report	2	1	1	
		7. Paint Shade	CR	Visual	100%	BHEL approved drg. / Spec.	BHEL approved drg. / Spec.	Inspection Report	2	1	1	
		8. Paint Thickness	CR	Measurement	100%	BHEL approved drg. / Spec.	BHEL approved drg. / Spec.	Inspection Report	2	1	1	
		9. Workmanship of Gaskets	MA	Visual	100%	Factory Standard	Factory Standard	Inspection Report	2	1	1	
		10. Wiring Layout	MA	Visual	100%	BHEL approved drg.	BHEL approved drg.	Inspection Report	2	1	1	
		11. Wire Termination	MA	Pulling manually	Sample	----	Firm termination	Inspection Report	2	1	1	
		12. Continuity	MA	Electrical	100%	----	Continuity OK	Inspection Report	2	1	1	

LEGEND: * CR - Critical characteristics MA - Major characteristics MI - Minor characteristics	<sup>§</sup> P - Agency Performing the Test. W - Agency Witnessing the Test. V - Agency Verifying the Test.	1 - BHEL 2 - Vendor 3 - Sub-vendor
---	---	--

Sl. No.	Component / operation	Characteristics Checked	* Category	Type/Method of Check	Extent of Check	Reference documents	Acceptance Norms	Format of Records	Agency <sup>\$</sup>			Remarks
									P	W	V	
 <b>STANDARD QUALITY PLAN FOR LOCAL CONTROL PANEL</b>									STD QUALITY PLAN NO.: <b>PE-QP-999-145-I056</b>			
									VOLUME IIB			
									SECTION C3			
									REV. NO. 01			
									SHEET 7 OF 7			
13.	<b>TYPE TEST</b>	Degree of Protection	CR	Mech. Protection	Sample	BHEL approved spec., drg relevant IS-13947 Part-1, IS-2148.	BHEL approved spec., drg relevant IS-13947 Part-1, IS-2148.	Type Test Certificate	3	---	1	
14	<b>ROUTINE TEST</b>	IR before & after HV Test	CR	Electrical	100%	BHEL approved spec., drg., BOM & relevant IS.	BHEL approved spec., drg., BOM & relevant IS.	Test Report	2	1	1	
15	<b>FUNCTIONAL TEST</b>	1. Control Logic Operation	CR	Electrical	100%	BHEL approved spec. / drg.	BHEL approved spec. / drg.	Inspection Report	2	1	1	
		2. Instrument Calibration	CR	Electrical	10%	BHEL approved spec. / drg.	BHEL approved spec. / drg.	Inspection Report	2	1	1	
		3. Temperature rise	CR	Electrical	100%	BHEL approved spec/drg. & relevant IS.	BHEL approved spec/drg & relevant IS.	Inspection Report	2	1	1	

LEGEND: \* CR - Critical characteristics  
 MA - Major characteristics  
 MI - Minor characteristics

<sup>\$</sup> P - Agency Performing the Test.  
 W - Agency Witnessing the Test.  
 V - Agency Verifying the Test.

1 - BHEL  
 2 - Vendor  
 3 - Sub-vendor



**TITLE:**  
**TECHNICAL SPECIFICATION FOR  
OZONE GENERATION PLANT**  
**1X700 MW BELLARY THERMAL POWER  
STATION UNIT NO. 3, STAGE-3**

BHEL DOCUMENTS NO.: PE-TS-367-174-14000A-A001

VOLUME **II-B**

SECTION -C3

REV. NO. 01

DATE: 24/02/2014

**SPECIFIC TECHNICAL REQUIREMENT FOR C&I ITEMS**

# SPECIFIC TECHNICAL REQUIREMENT

KPCL/BTPS/03/EPC 	KARNATAKA POWER CORPORATION LIMITED BELLARY TPS, UNIT-3 OF 700 MW
	TITLE DESIGN, PERFORMANCE AND FUNCTIONAL REQUIREMENTS

Operator's command execution time : 1 sec  
 DAS data update time : 1 sec  
 Closed loop control update time of 200 m sec for critical loops & 500 m sec for other loops (from change of output of the sensor of the transmitter/ temperature element to the corresponding control command output).  
 Open loop control update time of 50-100 m sec.  
 However, for SG/TG protections higher speed shall be considered as per manufacturer's requirement.

Controller loading : Max. 60%  
 Data bus loading : Max 50%  
 Overall system availability : 99.7%

5.6.02 **Worst Loading Conditions :**

For distributed control system the worst loading condition shall include the following tasks :

- (a) All process inputs scanning and processing is in progress and all the data is transmitted over the main data bus every one second.
- (b) All closed loop controls in operation
- (c) All open loop controls in operation
- (d) All output devices are in operation with rated performance/speed.
- (e) Control/information request is initiated on control VDU.
- (f) In burst mode operation, 100 digital alarms are generated per second for a period of 10 seconds.

6.0.00 **General Guidelines for Provision of Instruments/Instruments to be provided for Systems/Equipment:**

6.1.00 Bidder shall provide the various field instruments, in-line instruments directly mounted on pipe and panel mounted instruments including the accessories as required for different systems/equipment of the plant as per the guide lines given in clause of this section below.

6.1.01 Bidder shall include the field sensors/transmitters/ initiating devices for the following :

1. Sensors/transmitters required for all closed loop controls shall be provided considering the sensor level redundancy for controlled parameters and parameters required for compensation.
2. Sensors/initiating devices required for all open loop controls shall be provided considering the sensor level redundancy as required and as called for.
3. Sensors/transmitters required for measurement system.
4. Sensors/Initiating Devices shall be provided for status indication on CRT of various drives required for the plant.
5. Initiating Devices/contacts shall be provided for fault/abnormal conditions of the process/equipment/ systems for Sequence of events recording and Annunciation System.
6. Necessary field sensors, smart converters, smart transmitters, temperature elements, probes, transducers, process switches viz, pressure, temperature,

## SPECIFIC TECHNICAL REQUIREMENT

KPCJ/BTPS/03/EPC 	<b>KARNATAKA POWER CORPORATION LIMITED</b>
	<b>BELLARY TPS, UNIT-3 OF 700 MW</b>
	<b>TITLE</b> DESIGN, PERFORMANCE AND FUNCTIONAL REQUIREMENTS

level, flow & limit switches etc, required for functional completeness and/or otherwise felt necessary by Bidder, with all necessary stubs, bosses, first isolation (Root) valves, cocks, manifolds, instrument isolation & drain valves, impulse pipes & tubes, mounting stands & brackets, protection covers, racks & canopies, mounting accessories etc, terminated to local junction boxes / proximeter housings with suitable type of cables, glands, lugs and sleeves, conductor marker /ferrule. Technical specifications provided elsewhere, as part of this specification shall apply as the technical guideline.

7. Pressure instrument shall have the unit suffixed with 'a' or 'g' to indicate absolute or gauge pressure, respectively. Scales and charts of all instruments shall have linear graduations. Deviation indicators shall have the null position at mid scale. The normal operating parameter shall be identified with a clear green mark.

6.2.00 Selection of Ranges for Instruments:

6.2.01 The ranges of the instruments shall be selected based on the philosophy indicated below:

1. For pressure and draft measurements, the maximum operating pressure will be within 70 to 80% of the maximum scale range. All pump suction measurement and steam pressure measurements in extraction steam and in heaters will cover the negative pressure range also and all draft gauges will cover the negative pressure as well as the positive pressure as the case may be.
2. For temperature measurement, the maximum operating temperature will be within 80 to 90% of the maximum scale range.
3. For pressure switches and temperature switches, the set points shall fall within 40% to 70% of the scale range selected.
4. All displays shall be in engineering units. Instrument scales displayed on screen will have graduations with scale divisions based on multiples of 10. The smallest division shall preferably be a whole number approximately 1% of the scale range if not otherwise impracticable.
5. For level measurement, the maximum of the range will cover the overflow point or six inches from the top of the vessel and the minimum of the range will be six inches above the bottom of the vessel. Also, the gauge glasses will be stacked with overlap to cover permissive, alarm and trip levels.
6. For flow measurement, the maximum range shall be fixed at about 10 to 15% above the maximum operating flow.
7. For electro-chemical measurements (conductivity, pH, dissolved O<sub>2</sub>, Silica etc.), the maximum range will be around 10 to 15% higher than the recommended alarm settings.

6.2.02 Engineering units:  
The following system of units shall be followed for various displays and scales Unless otherwise mentioned shall be

1. Pressure: Kg/cm<sup>2</sup>

## SPECIFIC TECHNICAL REQUIREMENT

<p>KPCL/BTPS/03/EPC</p> 	<p><b>KARNATAKA POWER CORPORATION LIMITED</b> <b>BELLARY TPS, UNIT-3 OF 700 MW</b> TITLE <b>DESIGN, PERFORMANCE AND FUNCTIONAL REQUIREMENTS</b></p>
	<ol style="list-style-type: none"> <li>2. Differential Pressure: mm of H<sub>2</sub>O column / Kg/cm<sup>2</sup></li> <li>3. Draught: mm of H<sub>2</sub>O column</li> <li>4. Vacuum : mm of H<sub>2</sub>O column</li> <li>5. Temperature : Degree Celsius (O C)</li> <li>6. Flow (Steam, Water): Tonnes / hr.</li> <li>7. Flow (Oil) : Tonnes/hr</li> <li>8. Flow Air : Tonnes / hr</li> <li>9. Density : gms/c.c</li> <li>10. Level : mm</li> <li>11. Conductivity : Micro-mho / cm</li> <li>12. Gas Analyzer: Percentage by weight or as specified in respective case.</li> <li>13. Dissolved Oxygen / Silica / : ppm or ppb Sodium / Hydrogen</li> <li>14. Coal flow : Tones / hr</li> <li>15. Speed : RPM</li> </ol> <p>6.3.00 <b>The general guidelines for various instruments, which have to be provided on Plant equipments/systems are elaborated below.</b></p> <p>6.3.01 <b><u>Pressure indicators</u></b> shall be provided for</p> <ol style="list-style-type: none"> <li>1. Suction and discharge lines of pumps/fans, including on suction/discharge header if two or more pumps are employed for the same service.</li> <li>2. All input and output lines of process equipment.</li> <li>3. Inlets and outlets of heaters, heat exchangers and desuperheaters.</li> </ol> <p>6.3.02 <b><u>Pressure Switches</u></b> shall be provided</p> <ol style="list-style-type: none"> <li>1. On all process lines/Equipment where parameter abnormality/status including pre trips alarms to be communicated to the operator in control room.</li> <li>2. For all permissive conditions governed by safety operation of the equipment. eg. pr. adequate, conditions.</li> <li>3. For all protection conditions. Eg. pr. very high/very low conditions</li> <li>4. For all interlock conditions which governs starting of standby equipment or subsequent equipment for safety operation of the system.</li> <li>5. 3 switches shall be employed for protection in case of critical applications</li> <li>6. Inlet and outlet of filters/strainers.</li> </ol> <p>6.3.03 <b><u>Differential Pressure Switches</u></b> shall be provided</p> <ol style="list-style-type: none"> <li>1. Across filters/strainers for remote monitoring</li> <li>2. Across condenser CW line for remote monitoring and interlocks</li> </ol> <p>6.3.04 <b><u>Differential Pressure Indicators</u></b> shall be provided</p> <ol style="list-style-type: none"> <li>(a) Across filters/strainers for local monitoring</li> <li>(b) Across condenser CW line for local monitoring</li> </ol> <p>6.3.05 <b><u>Pressure Transmitters</u></b> shall be provided</p> <ol style="list-style-type: none"> <li>1. At suction and discharge of all major pumps/fans.</li> <li>2. For all control and monitoring applications as demanded by the process. It shall be noted that for all critical analog/binary controls applications 3</li> </ol>

## SPECIFIC TECHNICAL REQUIREMENT

KPCL/BTPS/03/EPC 	<b>KARNATAKA POWER CORPORATION LIMITED</b>
	<b>BELLARY TPS, UNIT-3 OF 700 MW</b> TITLE <b>DESIGN, PERFORMANCE AND FUNCTIONAL REQUIREMENTS</b>

transmitters shall be provided.

3. Pressure conditions of all major vessels/tanks like Deaerator, Hotwell, Boiler Drum etc.
4. All inputs for equipment/unit performance calculation.

6.3.06 **Differential Pressure Transmitters** shall be provided,

1. For all the requirements of differential pressure, flow and level measurements. For critical control applications 3 transmitters shall be provided.
2. All inputs for equipment/unit performance calculation.
3. Auxiliary cooling water services flow measurement instead of variable area flow meters.

6.3.07 **Temperature indicators (Thermometers)** shall be provided

1. On all process lines where local indication is warranted by the system either for monitoring or testing.
2. On the inlet/outlet equipments such as heaters, desuperheaters, Heat Exchangers & Coolers for both the fluid media.
3. Capillary type temperature indicators shall be used in vibration prone areas.
4. Thermowell shall be provided for all temperature indicators.

6.3.08 **Temperature Switches** shall be provided

1. For all process lines where parameter abnormality to be communicated to the operator in control room where redundant transmitters are not provided
2. For all permissive & interlock conditions governed by the safety operation of the equipment where redundant transmitters are not provided and for protection of the equipment.
3. For all critical services 3 nos. shall be provided for protection application.

6.3.09 **Resistance temperature detectors (RTD's)** shall be provided for all services where maximum temperature does not exceed 150 degrees centigrade.

1. The element shall be 3 wire type/4 wire, duplex with all thermowell.
2. The RTD is employed for remote display for providing necessary information to the operator about the performance of the related equipment such as pumps, fans, Motors..etc Eg : Suction/Discharge of pumps and fans inlet/outlet of heat exchangers, fans / pumps bearings, motor windings, motor bearings etc.

6.3.10 **Thermocouples** shall be provided for all services where normal operating temperature exceeds 150 deg C.

1. The element shall be duplexed integral with thermowell. K-type for temperature upto 600 degC and R- type for temperature above 600 degC.
2. The thermocouple is employed for remote display, for control applications, density correction for flow measurements.
3. All thermocouple shall be directly connected to the respective input modules in DDCMIS through Extension/Compensating cables. The extension/compensating cables shall be laid from T/C till DDCMIS

## SPECIFIC TECHNICAL REQUIREMENT

KPC/L/BTPS/03/EPC 	<b>KARNATAKA POWER CORPORATION LIMITED</b>
	<b>BELLARY TPS, UNIT-3 OF 700 MW</b>
	<b>TITLE</b> <b>DESIGN, PERFORMANCE AND FUNCTIONAL REQUIREMENTS</b>

cabinets and the cold junction compensation shall be carried out at DDCMIS. Extension cables shall be supplied for K & T type Thermocouples and Compensating cables for all R & S Type Thermocouples.

4. Metal temperature thermocouples shall be provided for the services like pipe metal, separator/Drum, SH/RH tube metal temperature. For metal thermocouples suitable pads with clamps etc., shall be provided. The termination of these thermocouples shall be at low temperature area with adequate extension length of thermocouples.

6.3.11 **Thermo wells** shall be provided along with Temperature elements of RTD & Thermocouples except for metal/bearing/winding temperature measurements.

1. For measurement of flue gas temperature, Inconel coated with tungsten carbide or suitable abrasion resistant thermo wells shall be provided.
2. For measurement of pulveriser outlet temperature tungsten carbide block thermo wells abrasion resistant not tungsten carbide coated thermowell shall be used. Also the terminals of Thermocouple shall not be at the top of Mills itself. The thermocouple wires are to be laid up to JB through SS tubing of required diameter and the head shall be placed nearer to the JB. Compensating cable exposed to atmosphere in the conventional method melts away due to high temperature at the top of Mill.
3. For measurement of water & steam temperature SS thermo wells or better, shall be used.

**Temperature Transmitters** are not envisaged.

6.3.12 **Level gauges** shall be provided

1. On all tanks and the maximum length of one gauge glass shall not exceed 1 metre. The gauge glasses shall be stacked to cover the complete height of the tanks including over flow level. There shall be an overlap of minimum 150 mm, when more than one level gauge is required. Suitable platforms shall be provided for purpose of taking measurements during maintenance..
2. All high pressure vessel shall be provided with level gauges on either end as per Boiler statutory requirement.

6.3.13 **Level switches** shall be provided,

1. On all equipment (storage vessel) where parameter abnormality/status to be communicated to the operator in the control room.
2. All permissive and interlock conditions governed by the safety operation of the equipment and for protection conditions.
3. For all critical services, 3 switches shall be provided for protection application.
4. The instrument shall be external cage type with SW connection with isolation facility for surface mounted tanks and top mounted with still pipe for all sumps.

6.3.14 **Level transmitters** shall be provided on process equipment where continuous remote monitoring and/or control of level is envisaged.

## SPECIFIC TECHNICAL REQUIREMENT

<p>KPCL/BTPS/03/EPC</p> 	<p style="text-align: center;"><b>KARNATAKA POWER CORPORATION LIMITED</b></p> <p style="text-align: center;"><b>BELLARY TPS, UNIT-3 OF 700 MW</b></p> <p>TITLE     <b>DESIGN, PERFORMANCE AND FUNCTIONAL</b> <b>REQUIREMENTS</b></p>
	<ol style="list-style-type: none"> <li>1. The instrument shall be displacement type for all pressure/vacuum applications involving two phase media like Hotwell, LPH services..etc</li> <li>2. The instrument shall be differential pressure type for other applications with pressure.</li> <li>3. Other type of level transmitters viz., Ultrasonic, RF Type, Radar Type, capacitance Type ..etc for special applications.</li> </ol> <p>6.3.15     <b>Flow Glasses</b> at the outlet of the pipe line shall be employed under the following conditions:</p> <ol style="list-style-type: none"> <li>1. Coolant from the equipment (coolers)</li> <li>2. The instrument shall be rotary type with glass mounted for indication.</li> <li>3. Upto 4 inch on-line flow glasses shall be supplied and above 4 inch bypass type flow glasses shall be provided.</li> </ol> <p>6.3.16     <b>Flow Switches</b> shall be provided at different outlet header of identical equipment to alarm in the event of inadequate coolant requirement (or) lube oil, cooler outlet on cooling water line.</p> <p>6.3.17     <b>Speed Measurement</b> shall be provided, where variable speed drives are to be controlled from remote e.g., BFP, ID fans , Feeders etc.</p> <p>6.3.18     <b>Coriolis type mass flow Meters</b> shall be provided for the measurement of HFO, LFO and DM Water flow measurement.</p> <p>6.3.19     <b>Flow Elements</b> shall be provided as mentioned below.</p> <ol style="list-style-type: none"> <li>1. Orifice plate shall be provided for spray water, condensate, makeup water, DM water, soot blowing system.</li> <li>2. Flow nozzle shall be provided for BFP suction, Feedwater, HP Bypass, Aux. steam system.</li> <li>3. Impact head type element (Annubar) type/Orifice shall be provided for condenser cooling water system.</li> <li>4. Aerofoil for secondary air flow</li> <li>5. Venturi for primary air flow measurement or as per proven standard and practice of boiler supplier.</li> <li>6. The flow element connection shall be Butt welded except for applications, where flanged connection have to be used.</li> <li>7. Flow elements shall be provided with three (3) sets of tap points with independent root valves.</li> </ol> <p>6.3.20     <b>Control valves</b> shall be provided</p> <ol style="list-style-type: none"> <li>1. For all control application as required and in line with the system requirement.</li> <li>2. If the process demands any other control, then control valves shall be provided for those applications also.</li> <li>3. Where a single control valve can not meet the turned down ratio as dictated by the process, control valves with split range application, shall be provided.</li> <li>4. All bypass valves of control valves as detailed in section - D1 shall be suitable for inching operation and provided with position transmitters.</li> <li>5. Control valves for HP &amp; LP Bypass system shall be hydraulic operated.</li> </ol>

## SPECIFIC TECHNICAL REQUIREMENT

<p>KPCL/BTPS/03/EPC</p> 	<p style="text-align: center;"><b>KARNATAKA POWER CORPORATION LIMITED</b></p> <p style="text-align: center;"><b>BELLARY TPS, UNIT-3 OF 700 MW</b></p> <hr/> <p>TITLE     <b>DESIGN, PERFORMANCE AND FUNCTIONAL REQUIREMENTS</b></p>
<p>6.3.21</p> <p>6.3.22</p> <p>6.3.23</p> <p>6.3.24</p> <p>6.3.25</p>	<p>6. Control valves for modulating shall be pneumatically operated. Control valves in high pressure services shall have welded end connections. Control valves and actuators shall be equipped with standard accessories like air filter regulator with pressure gauge, valve positioners with E/P converter &amp; pressure gauges, position transmitters, handwheel, limit switches, air failure lock etc.</p> <p>The general specification of the control valves is detailed in Section-D3.4.</p> <p><b>Solenoid valves</b> shall be provided with pneumatic control valves hooked up with process interlock requirements and where direct tripping is involved. The number of ways for solenoid valve shall be provided as indicated below</p> <ol style="list-style-type: none"> <li>1. Two (2) way solenoid valves shall be provided, where process line of less than 2 inch with low pressure &amp; temperature application. Eg : ACW overhead tank make up line.</li> <li>2. Three (3) way solenoid valve shall be provided commonly, where the pressure is admitted or exhausted from a diaphragm valve or single acting cylinder. Eg: Pneumatic operated spray water block valve.</li> <li>3. Four (4) way solenoid valve shall be provided for operating double acting cylinders. Eg: Pneumatically operated on-off type dampers</li> <li>4. Dual coil solenoid valves shall be supplied for protection application and single coil for open/close application.</li> </ol> <p><b>Control Dampers (Modulating)</b> shall be provided for air &amp; flue gas control application. If process demands any other control, the necessary control dampers shall be provided for those applications.</p> <p><b>Valve/Damper Actuators Accessories:</b></p> <p>All pneumatic actuators (valves/dampers) included in the scope of BIDDER for ON/OFF and regulating services shall be complete with all accessories including the following: Hand wheel with lock, Air filter regulator, Air lock relay, Pneumatic tubing from nearest air header to the actuator complete with all necessary fittings, Positioner for regulating services, End position (open/close) limit switches, Local position indicator and non contact type position transmitter with 2 wire 4-20mA DC output for regulating services, Necessary solenoid valves required for open/close operation &amp; interlock functions, Electro-pneumatic (E/P) converters for the regulating services, suitable for accepting 4- 20mA DC signal, Junction box near the valve for terminating the limit switch/position transmitter/E-P converter signals.</p> <p><b>Position Transmitters</b> shall be provided for all control valves, control damper and bypass valves/dampers, where modulating/inching operation is required. Position transmitters shall be non-contact type. The general specification is given in Section-D3.4.</p> <p><b>Electro-Pneumatic Converters</b> shall be provided for all pneumatically</p>

## SPECIFIC TECHNICAL REQUIREMENT

KPCL/BTPS/03/EPC	KARNATAKA POWER CORPORATION LIMITED
	BELLARY TPS, UNIT-3 OF 700 MW
	TITLE DESIGN, PERFORMANCE AND FUNCTIONAL REQUIREMENTS

operated control valves, control dampers, power cylinders etc., for converting controller output of 4-20 mA to 3-15 PSI for interfacing with pneumatic actuators. In case of single E/P converter is driving more than one positioner, then its air out put shall have sufficient capacity.

6.3.26 Air Filters Regulators shall be provided in the

1. Air supply line to valve positioners/power cylinders
2. Air supply line to electrical to pneumatic converters
3. Air supply line to pneumatic interlocked block valves
4. For each Instrument Rack/Local panel field instruments enclosure for purging.

6.3.27 Analytical Instruments:

a. Steam and water quality measurement:  
The various analytical instruments complete with their sampling system and sampling racks shall be provided for continuous monitoring of the quality of the process fluid as per Table-3.  
These analysers shall be kept in an air conditioned room. The specification details for analysers, sample coolers and sampling racks shall be as per section-D3.4.

b. Gas Analysers:  
The following gas analysers shall be provided at the location indicated below:

1. Economiser outlet or Each of Air preheater Inlet : Oxygen
2. Each of Air preheater outlet : Oxygen
3. ID fan outlet : Particulate Emission Analyser.
4. Stack : i) Sample Extractive type SO<sub>2</sub>, NO<sub>X</sub>, CO  
ii) Particulate emission.

Bidder shall also provide Oxygen measurement in high temperature zones of boiler for combustion control and performance analysis, if required.  
The specification details for gas analyser is given in section-D3.4.

6.3.28 Interposing Relays shall be provided,

1. For all drive commands, (HT,LT,BIDIRECTIONAL, SOLENOID, DC DRIVE etc.,)
2. Potential free contacts required between systems for unit / equipment trip, protection & interlocks applications...etc

The Interposing relays' provided are independently mounted in MCC/Integral starter/DDCMIS cabinets or in separate cabinets.

6.3.29 Transmitter Racks  
All the pressure, flow and level transmitters shall be grouped depending on the geographical locations and mounted on Transmitter Racks. The general specification of transmitter racks is given in Section-D3.4.

## SPECIFIC TECHNICAL REQUIREMENT

<p>KPCL/BTPS03/EPC</p> 	<p><b>KARNATAKA POWER CORPORATION LIMITED</b> <b>BELLARY TPS, UNIT-3 OF 700 MW</b></p> <p>TITLE <b>SPECIFICATIONS FOR DDCMIS/INSTRUMENTS TO BE SUPPLIED</b></p>	
<p>also 2 sets to be mounted on Unit control desk.</p> <p>3.00.06 The alarm windows and group alarms shall be freely configurable without wiring changes from PC based OWS.</p> <p>3.00.07 Contact multiplication (Buffer terminal cabinets)cabinets with optical isolation input cards required for UCP &amp; ECP alarm points shall be provided as per requirement.</p> <p><b>4.00.00 <u>TECHNICAL SPECIFICATIONS FOR FIELD INSTRUMENTS, PLC, VMS, CCTV AND OTHER EQUIPMENT/SYSTEMS</u></b></p> <p>All instruments offered by the bidder shall be from reputed experienced manufacturers of specified type and range of equipment, whose guaranteed and trouble free operation has been proven as mentioned in design criteria. Further, all instruments shall be of proven reliability, accuracy, and repeatability requiring a minimum of maintenance. They shall comply with the acceptable international standards and shall be subject to Employer's approval. All instrumentation equipment and accessories under this specification shall be furnished as per technical specifications.</p> <p>The Contractor shall furnish all Instrumentation/ Control equipment &amp; accessories under this specification as per technical specification, ranges, makes &amp; model as approved by the Employer during detailed engineering. The necessary root valves, impulse piping, drain cocks, gauge-zeroing cocks, valve manifolds and all the other accessories required for mounting/ erection of these transmitters shall be furnished, even if not specifically asked for, on as required basis. Double root valves shall be provided for all pressure tapping where the pressure exceeds 40 Kg./sq.cm.</p> <p>4.00.01 <u>Smart Electronic Transmitters for Measurement of Pressure, Differential Pressure(DP) &amp; Flow/Level(DP Type):</u></p> <p>4.00.02 Micro-processor based indicating type (LCD display), rack mounted with accuracy of +/- 0.1% of span, Repeatability : +0.05% of FSR or better, Linearity :+0.1% of FSR or better. Hystersis: +0.1% of FSR or better. external zero and span adjustment, self diagnostics, temperature sensor for compensation. Power supply 24 V DC; output signal of 4- 20 mA DC. IP 65 or equivalent degree of protection with epoxy coating, 316 SS/ haste alloy/ other suitable sensing element. Accessories like snubbers for pump discharge applications and chemical diaphragm with 15 m PVC covered SS armoured capillary for corrosive and oil services, etc. Material for accessories will be SS. HART protocol output shall be available in each transmitter.</p> <p>In case it becomes necessary to use a DP transmitter for pressure measurement then a 3-valve manifold should be used in place of 2-valve manifold. LVDT type is not acceptable.</p> <p>4.00.03 Wherever, the process fluids are corrosive, viscous, solid bearing or slurry type, diaphragm seals shall be provided. Parts below the diaphragm shall be removable</p>		

## SPECIFIC TECHNICAL REQUIREMENT

<p>KPCL/BTPS03/EPC</p> 	<p><b>KARNATAKA POWER CORPORATION LIMITED</b> <b>BELLARY TPS, UNIT-3 OF 700 MW</b></p> <p>TITLE <b>SPECIFICATIONS FOR DDCMIS/INSTRUMENTS TO BE SUPPLIED</b></p>	
<p>for cleaning. The entire volume above the diaphragm shall be completely filled with an inert liquid suitable for the application.</p> <p>4.00.04 <b><u>In Detail Technical Specification:</u></b></p> <ol style="list-style-type: none"> <li>1) Type of Transmitter: Microprocessor based 2 wire type HART protocol compatible,</li> <li>2) Accuracy : - +/- 0.1 % of span</li> <li>3) Output Signal Range: 4-20 mA DC (Analog) <i>Superimposed digital on HART protocol</i></li> <li>4) Turn Down Ratio : 10:1 for vacuum/very low pressure applications 30:1/100:1 for other applications</li> <li>5) Stability: +/- 0.1% of calibrated span for 6 months up to 70 KSC &amp; +/- 0.25% for range more than 70 KSC(g).</li> <li>6) Zero and Span Drift: +/- 0.015% per Deg.C at max. span and 0.11% per Deg.C at Minimum Span</li> <li>7) Load Impedance: 500 ohm (Min)</li> <li>8) Housing: Weather proof as per IP-65 with durable corrosion resistant coating</li> <li>9) Over Pressure - 150 % of Max. operating pressure</li> <li>10) Connection (Electrical)- Plug and socket type</li> <li>11) Process Connection - 1/2 inch NPT (F)</li> <li>12) Span and Zero: Continuous, tamper proof, Remote Adjustability as well as manual from instrument with zero suppression and elevation facility.</li> <li>13) Accessories             <ol style="list-style-type: none"> <li>a) Diaphragm seal, pulsation dampeners syphon etc. as required by service and operating condition.</li> <li>b) 2/3/5 Valve manifold as applicable</li> </ol> </li> <li>14) Diagnostics: Self Indicating Feature</li> <li>15) Power Supply: 24 V DC +/- 10%</li> <li>16) Adjustment : Calibration facility via Centralized PC based HART management system</li> </ol> <p><b>In addition to the transmitters 3 Nos. of hand held calibrators for configuration shall be provided for maintenance of units.</b></p> <p>5.00.00 <b><u>Coriolis Type Smart Mass Flow Meter :</u></b></p> <p>Bidder shall provide Coriolis type Mass Flow Meter for flow measurement of HFO (Main &amp; Return), LDO and DM water flow to Unit. The technical details are Accuracy - 0.2% of FS, Repeatability - 0.1%, Output - 4-20 mA, Protection - IP-65 and Hazardous Area- Flame proof Classification for LFO/HFO.</p>		

## SPECIFIC TECHNICAL REQUIREMENT

<p>KPCL/BTPS03/EPC</p> 	<p><b>KARNATAKA POWER CORPORATION LIMITED</b> <b>BELLARY TPS, UNIT-3 OF 700 MW</b></p> <hr/> <p>TITLE <b>SPECIFICATIONS FOR DDCMIS/INSTRUMENTS TO BE SUPPLIED</b></p>	
<p><b>6.00.00 Displacement Type Level Transmitters:</b></p> <p>6.00.01 Displacement Type Smart Electronic Level Transmitters shall be provided for level measurement of condenser hotwell level, LP Heaters, HP Heaters and other vacuum services, shall be considered by the bidder. If any more transmitters over and above the quantity indicated are required for the safe and efficient operation and maintenance the same shall be included. The type/ranges/make of transmitters and services for which these transmitters are required shall be as decided and approved by the owner during detailed engineering.</p> <p>6.00.02 Microprocessor based smart type, displacement type level transmitters of float length of 14 inches or 32 inches with an accuracy of +/-0.5% of span, 4-20 mA DC output (2 wire system), +24 V DC supply, isolated and ungrounded electrical circuits, zero adjustment (100% of sensing element) for control application and measurement purposes for all services of condensate and drains, particularly where two phases of steam and water are present. IP 65 or equivalent degree of protection for enclosure. Displacer/float material of 316SS. The material of accessories will be SS.</p> <p><b>7.00.00 Impact Head Type Flow Element:</b></p> <p>7.00.01 The impact head type element (annubar) shall be tubular insert type with minimum four impact ports facing upstream direction, located precisely for determination of average flow velocity. The material of the sensor shall be 316 SS. Accuracy shall be +/- 1.0 % of actual value or better. Repeatability shall be +/- 0.01 % of actual value or better.</p> <p>7.00.02 The elements shall be supplied complete with mounting hardware, end support plugs and CS valve manifold (1/2" NPT connection) for instrument connections. All pertinent data including OWNER's instrument Tag No. for the flow element shall be punched on a stainless steel plate and affixed to the element.</p> <p>7.00.03 On line retracting facility and flushing arrangement shall be provided. Anubar Type flow element shall be used for measurement of C W flow. Bidder shall submit all sizing calculations, precise flow calculations, fabrication and assembly drawings, installation drawings for all the flow elements for OWNER's review and approval.</p>		

## SPECIFIC TECHNICAL REQUIREMENT

<p>KPCL/BTPS03/EPC</p> 	<p align="center"><b>KARNATAKA POWER CORPORATION LIMITED</b></p> <p align="center"><b>BELLARY TPS, UNIT-3 OF 700 MW</b></p> <p>TITLE    <b>SPECIFICATIONS FOR DDCMIS/INSTRUMENTS TO BE SUPPLIED</b></p>
<p><b>8.00.00</b></p>	<p><b><u>Digital Display Unit</u></b> To display the digital value of any analog process parameter with sign and decimal point of any analog input assigned though operator. Accuracy shall be <math>\pm 0.25\%</math> of reading; shall be of size 2". type of display - LED; Seven segment or dot matrix type; five digits, sign and decimal point; colour of display shall be Green ; enclosure shall be IP32 or equal; all DDU's shall be mounted on the Unit Control Panel. For outdoor applications, the size shall be 6". DDU used outside control room shall be of Dot matrix type.</p>
<p><b>9.00.00</b></p>	<p><b><u>THERMOCOUPLE ASSEMBLY WITH THERMOWELL</u></b></p> <p>Duplex type with accuracy of <math>\pm 0.5\%</math> of span (as per IEC-584 class-I for turbine applications) response time of 2 to 6 sec, Spring loaded mineral insulated thermocouple assembly with 316 SS thermowell housed in aluminium casing (epoxy coated) having a process connection of M33 x 2 thread or 150 RF flanged. Material of accessories will be SS. IP 65 or equivalent degree of protection for enclosure. Thermowell with hex head of fabricated assembly for air and flue gas system, for rest of the services bar stock assembly ungrounded.</p> <p>Thermowell material shall be solid tungsten carbide for mill outlet temperature measurement. For Air &amp; Flue Gas measurements, thermowells shall be made of Inconel. For metal temperature measurement, thermocouple pads weldable to M.S pipes shall be provided with 15 m thermocouple extension wires. Element size shall be 18 AWG. Insulation resistance at 540°C shall not be less than 5 M ohms. For Turbine applications process connection shall be welded as per DIN 43763.</p> <p>Temperature devices provided with thermowell shall be calibrated with the associated thermowell as an assembly. The thermowell construction shall meet the ANSI 19.3-1994 (latest) requirements. Thermocouple termination head shall be 300 mm above the pipe insulation to avoid cable damage in hot zones.</p> <p><b><u>Thermo wells</u></b> shall be provided along with Temperature elements of RTD &amp; Thermocouples except for metal/bearing/winding temperature measurements.</p> <ol style="list-style-type: none"> <li>1. For measurement of flue gas temperature, Inconel coated with tungsten carbide or suitable abrasion resistant thermo wells shall be provided.</li> <li>2. For measurement of pulveriser outlet temperature tungsten carbide block thermo wells abrasion resistant not tungsten carbide coated thermowell shall be used. Also the terminals of Thermocouple shall not be at the top of Mills itself. The thermocouple wires are to be laid up to JB through SS tubing of required diameter and the head shall be placed nearer to the JB. Compensating cable exposed to atmosphere in the conventional method melts away due to high temperature at the top of Mill.</li> <li>3. For measurement of water &amp; steam temperature SS thermo wells or better, shall be used</li> </ol>

## SPECIFIC TECHNICAL REQUIREMENT

KPCL/BTPS03/EPC  	<p style="text-align: center;"><b>KARNATAKA POWER CORPORATION LIMITED</b> <b>BELLARY TPS, UNIT-3 OF 700 MW</b></p> <hr/> TITLE <b>SPECIFICATIONS FOR DDCMIS/INSTRUMENTS TO BE SUPPLIED</b>	
	<p><b>10.00.00    RESISTANCE TEMPERATURE DETECTORS (RTD) WITH THERMOWELL:</b> Duplex type with accuracy of +/-0.5% of span, response time 1-2 seconds; Spring loaded mineral insulated three (3) wire RTD assembly with 316 SS Thermowell housed in aluminium casing (epoxy coated) having a process connection of M33 x 2 thread or 150 RF flanged. IP 65 or equivalent degree of protection for enclosure. Material of accessories will be SS. Thermowell with hex head with screwed cover &amp; SS chain, barstock assembly. Element lead size will be 18 AWG. The insulation resistance at 540° shall not be less than 5M ohms. Repeatability over full range shall be better than 0.02%. RTDs shall be ungrounded. RTD shall be supplied as an assembly complete with thermowell meeting ANSI 19.3-1994 (latest) requirements.</p> <p><b>11.00.00    Test Thermowells:</b> Pipe/equipment mounted temperature test wells of 316 SS with a process connection of M33x2 thread, except for Turbine applications process connection shall be welded as per DIN 43763. Material of accessories will be SS. Thermowell with hex head of fabricated assembly for air and flue gas system, for rest of the services bar stock assembly. The thermowell construction shall meet the ANSI 19.3-1994 (latest) requirements. The thermowells shall be hardfaced/sterlited to avoid erosion for boiler area applications</p> <p><b>12.00.00    <u>Pressure Indicators:</u></b> Direct reading, pipe mounted Pressure gauges of aluminium casing with six (6) inch phenolic dial (white dial with black numerals), 316 SS Bourdon tube, AISI304 /nylon movements and micrometer type adjustable pointer with an accuracy of +/-0.5% of span including accessories like syphons for steam services, snubbers for pump discharge applications and chemical diaphragm for corrosive and oil services and name plate. Material of accessories will be SS. IP65 or equivalent degree of protection for enclosure. Over range protection will be 50% above maximum pressure.</p> <p><b>13.00.00    <u>Pressure Switches:</u></b> Non indicating type, field mounted Pressure Switches of aluminium casing (epoxy coated), and 316 SS element and accuracy of +/-1% of span, including accessories like syphons for steam services, snubbers for pump discharge applications and chemical diaphragm for corrosive and oil services and name plate. Material of accessories will be SS. Auto reset micro switch with internal adjustment for set values with 2 SPDT contacts rated for 0.2 A at 220 V DC. IP 65 or equivalent degree of protection for enclosure. Over range protection 50% above maximum pressure. Scale for setting shall be provided.</p>	

# SPECIFIC TECHNICAL REQUIREMENT

KPCL/BTPS03/EPC	KARNATAKA POWER CORPORATION LIMITED
	BELLARY TPS, UNIT-3 OF 700 MW
	TITLE SPECIFICATIONS FOR DDCMIS/INSTRUMENTS TO BE SUPPLIED
<b>14.00.00</b>	<p><b><u>Differential Pressure Indicators:</u></b></p> <p>Direct reading type, pipe mounted, bellows or diaphragm operated differential pressure indicators; aluminium casing (epoxy coated) with six (6) inch dial (white dial with black numerals), with micrometer type pointer, 316 SS pressure element; an accuracy of <math>\pm 0.5\%</math> of span including accessories like snubbers for pump discharge application, chemical diaphragm with 15 m PVC covered SS armoured capillary for each limb for corrosive and oil services and 5 way manifold. Material of accessories will be SS. IP 65 or equivalent degree of protection. Over range protection will be 50% above maximum pressure.</p>
<b>15.00.00</b>	<p><b><u>Differential Pressure Switches:</u></b></p> <p>Bellows or diaphragm operated non-indicating field mounted type; aluminium casing (epoxy coated); 316 SS pressure element nylon movement; an accuracy of <math>\pm 1\%</math> of span with an adjustable contact including accessories like snubbers for pump discharge applications, chemical diaphragm with 15 m capillary for each limb for all corrosive and oil services and 5 way manifold. Material of accessories will be SS. Auto reset micro switch with adjustable set values with 2 SPDT contacts rated for 0.2 A at 220 V DC. IP 65 or equivalent degree of protection over range protection 50% above maximum pressure. Repeatability shall be <math>\pm 0.5\%</math> FSR.</p>
<b>16.00.00</b>	<p><b><u>Thermometers:</u></b></p> <p>Indicating type, field mounted, filled system with 5 metre capillary and six (6) inch dial housed in aluminium casing (epoxy coated) with an accuracy of <math>\pm 1\%</math> of span, response time of 2-4 seconds, auto temperature calibration, linear calibration over the range and 316 SS thermowell having a process connection of M33 x 2 thread. Material of accessories will be SS. IP 65 or equivalent degree of protection for enclosure. Thermowell with Hex head of fabricated assembly for air and flue gas system for rest of the services bar stock assembly. The thermowell construction shall meet the ANSI 19.3-1994 (latest) requirements.</p>
<b>17.00.00</b>	<p><b><u>Temperature Switch:</u></b></p> <p>Non Indicating type, field mounted, filled system with 5 metre capillary housed in Aluminium casing (epoxy coated) with an accuracy of <math>\pm 1\%</math> span, auto temperature calibration, linear calibration over the range and 316 SS thermowell having a process connection of M33x2 thread. Micro switch with reset type with adjustable set values with 2 SPDT contacts rated for 0.2 A, 220 DC. IP 65 or equivalent degree of protection for enclosure. Thermowell with hex head of fabricated assembly for air and flue gas system, for rest of the services bar stock assembly. Material of accessories will be SS. The thermowell construction shall meet the ANSI 19.3-1994 (latest) requirements.</p>

## SPECIFIC TECHNICAL REQUIREMENT

KPCL/BTPS03/EPC 	<b>KARNATAKA POWER CORPORATION LIMITED</b> : <b>BELLARY TPS, UNIT-3 OF 700 MW</b> TITLE <b>SPECIFICATIONS FOR DDCMIS/INSTRUMENTS TO BE SUPPLIED</b>
<p><b>18.00.00</b>    <b><u>Level gauges:</u></b></p> <p>Tubular type level gauges for low pressure upto 7 kg/cm<sup>2</sup> &amp; reflex type for high pressure water &amp; steam services &amp; vacuum services with automatic ball check valves, illuminator (240 AC), pyrex / borosilicate glass, mica shield, brass guard rods &amp; brass holders. Material of accessories (name plate, etc.) will be SS. Tubular glass OD will be 5/8". Vent &amp; drain valves shall be provided. Connection shall be screwed or flanged (ANSI class 150 RF). Enclosure shall be IP 65.</p> <p><b>19.00.00</b>    <b><u>Level Switches:</u></b></p> <p>External float operated level switches for tanks and vessels and top mounted level switches and underground tanks. The top mounted level switches shall be supplied with steel tubes to suit Purchaser's requirement. Micro switch with 2 SPDT contacts rated for 0.2 A, 220 V DC. Material of float &amp; float chord will be 316 SS &amp; cage material shall be fabricated steel and the material of accessories will be SS. IP 65 or equivalent degree of protection for enclosure.</p> <p>Accessories like name plate, drain valve for external case type level switches, mating flange, gaskets (asbestos), fasteners, bolts &amp; nuts, etc. shall be supplied.</p> <p><b>20.00.00</b>    <b><u>Flow Glasses:</u></b></p> <p>Online flow glasses for pipe size up to 4" with a rotary wheel (not a flapper type) suitable for installation on vertical or horizontal pipe lines, material pyrex tempered glass. Body material will be carbon steel, rotor &amp; wetted parts will be bronze. The material of accessories will be SS. IP 65 or equivalent degree of protection for enclosure. Upto 50 NB size, connection shall be screwed above 50 mm NB size it shall be flanged - ANSI, 150 RF. Accessories like name plate, mating flanges with gaskets (neoprene), bolts &amp; nuts, etc. shall be supplied. Enclosure shall be IP65.</p> <p><b>21.00.00</b>    <b><u>Flow Elements:</u></b></p> <p>SS 316 flow nozzles for all steam and feed water services with D and D/2 pressure tapplings; 316SS flow orifice plate assembly for all water services with flange tap connections; B ratio of 0.5 &amp; 0.7. Element material of SS 316. The material of accessories will be SS. All the flow elements shall have 3 pairs of differential pressure tapplings complete with root valves. Orifice plate shall not be less than 3 mm thick for nominal pipe diameter upto 300 mm &amp; not less than 6 mm thick for pipe diameter &gt; 300 mm. The flow elements shall be supplied as assemblies with High/low pressure tapplings, root valves as required. Performance Guarantee flow elements shall be provided</p>	

## SPECIFIC TECHNICAL REQUIREMENT

<p>KPCL/BTPS03/EPC</p> 	<p><b>KARNATAKA POWER CORPORATION LIMITED</b> <b>BELLARY TPS, UNIT-3 OF 700 MW</b></p> <p>TITLE <b>SPECIFICATIONS FOR DDCMIS/INSTRUMENTS TO BE SUPPLIED</b></p>	
<p>22.00.00</p>	<p>separately. Butt welded edges shall be prepared as per ANSI 16.25 &amp; flanged connections shall be as per ANSI 16.5 standards. Orifice assembly complete with nipples &amp; valves to be supplied by Bidder shall be one metre long with ANSI class 150 RF SS flanges at the ends including gaskets, bolts &amp; nuts. Isolating valves shall have SW end connection. Accessories like name plate, gaskets, bolts &amp; nuts, reservoirs (condensing chambers), 6 nos. shut off valves per assembly, nipple, welding adapters, etc. shall be supplied. Bidder shall submit certified flow calculation and differential pressure Vs. flow curves for each element for OWNER's approval. Sizing calculation, precise flow calculation for all the flow elements, fabrication and assembly drawings and installation drawings shall be submitted for OWNER's approval. Bidder shall provide three Tappings per flow elements.</p> <p><b><u>Flow Switches:</u></b></p> <p>Indicating, Differential pressure, flapper type on line flow switches for line sizes up to 80 mm with an accuracy of +/-2% of span and dial size of min. 50 mm having 316 SS flapper housed in die cast aluminium. Micro switch with adjustable range with 2 SPDT contacts rated for 0.2 A, 220 V DC. IP 65 or equivalent degree of protection for enclosure. The material of accessories will be SS.</p>	
<p>23.00.00</p>	<p><b><u>Flow integrators(Electronic Type):</u></b></p> <p>Flush mounted receiver type electronic digital flow integrators with accuracy 0.2%; linearity within 0.2%; six (6) digits, 24 V DC power supply. IP65 or equivalent degree of protection for enclosure; Accessories like square root extractor shall be provided.</p>	
<p>24.00.00</p>	<p><b><u>Air Filter Regulator (AFR):</u></b></p> <p>Constant bleed type AFR with an accuracy of +0.1%, inlet pressure range of 5-8 kg/cm<sup>2</sup> and suitable spring ranges (AFR) for use with positioners in control valves, control damper, E/P converters and shut off valves, transmitter purging lines etc; Filtering particles above five microns having phosphor bronze filter element. Material of accessories will be SS. Built in blow down valve shall be provided. AFR shall have automatic drain feature. All accessories shall be supplied. Degree of protection shall be IP65</p>	
<p>25.00.00</p>	<p><b><u>Electro-Pneumatic Converters (E/P):</u></b></p> <p>Two wire type E/P converters with an accuracy of +/-0.25% accepting 4-20 mA DC signals from control system and converting to 0.2 to 1 kg/cm<sup>2</sup> air pressure to operate valve positioner of all final control elements; Housed in cast aluminium casing (with polyurethane paint); IP65 degree of protection for enclosure. Material of accessories will be SS. Direct/reversing acting, 4 SCFM and above capacity</p>	

## SPECIFIC TECHNICAL REQUIREMENT

<p>KPCL/BTPS03/EPC</p> 	<p><b>KARNATAKA POWER CORPORATION LIMITED</b> <b>BELLARY TPS, UNIT-3 OF 700 MW</b></p> <p>TITLE <b>SPECIFICATIONS FOR DDCMIS/INSTRUMENTS TO BE SUPPLIED</b></p>
<p><b>26.00.00</b></p> <p><b>27.00.00</b></p> <p><b>28.00.00</b></p> <p><b>29.00.00</b></p>	<p><b><u>Position Transmitters:</u></b></p> <p>24 V DC operated Non contact type electronics/LVDT type, 4-20 mA, 2 wire system with an accuracy of +/-1%; range adjustment and zero adjustment to be provided; IP65 or equivalent degree of protection for casing. The output shall be linear. All accessories shall be SS.</p> <p><b><u>Solenoid Valves:</u></b></p> <p>Direct operated single/dual coil solenoid valves with shut off class (leakage) IV or better, body material of bronze, plunger material of 316 SS rated for continuous duty. IP 65 or equivalent protection class for enclosure. Insulation class of 'F' for the solenoid. Body ratings shall suit the pressure and temperature conditions.</p> <p>The operating voltage shall be for 24VDC/ 220VDC/230VAC/110VAC depending on the service.</p> <p><b><u>MAGNETIC FLOWMETER :</u></b></p> <p>Inline type with indicating top mounted transmitter with flange connection. Accuracy: 0.5% of flow rate or volume flow. Repeatability 0.1% of flow rate/volume flow. Transmitter shall be smart with LCD display and superimposed HART on 4-20mA DC output. Data storage shall be in EEPROM. Shall have diagnostic capabilities. Touch control facility on the indicator for checking the rate/volume and diagnostic messages.</p> <p>Material: Case-Al.alloy with corrosion resistant, flow tube and extension pipe-Stainless steel (SS 304) and Lining-fluro carbon.</p> <p>The flow rate shall be available in DCS/PLC and flow integration shall be implemented in DCS/PLC to indicate volume flow.</p> <p><b><u>Local Instrument Enclosure &amp; Racks/CICB.s:</u></b></p> <p>Transmitters mounted in the field shall be suitably grouped together and mounted in Local Instrument Racks (LIR). These local instrument racks shall be furnished as per the actual requirements finalised during detailed engineering stage. The exact grouping of instruments in a particular instrument rack shall be as finalised during detailed engineering stage subject to Employer's approval.</p> <p>The internal layout shall be such that the impulse piping/ blowdown lines are accessible from backside of the rack and the transmitters etc. are accessible from front side for easy maintenance. Bulkheads especially designed to provide isolation from process line vibration shall be installed</p>

## SPECIFIC TECHNICAL REQUIREMENT

KPC/BTPS03/EPC 	<b>KARNATAKA POWER CORPORATION LIMITED</b> <b>BELLARY TPS, UNIT-3 OF 700 MW</b> TITLE <b>SPECIFICATIONS FOR DDCMIS/INSTRUMENTS TO BE SUPPLIED</b>
<p>on instrument racks to meet the process sensing line connection requirement. Vibration dampeners shall be installed for each rack.</p> <p>The instrument racks shall be free standing type constructed of suitable 5 mm thick channel frame of steel and shall be provided with a canopy to protect the equipment mounted in racks from falling objects, water etc. The canopy shall not be less than 3 mm thick steel, and extended beyond the ends of the rack. Bulk heads, especially designed to provide isolation from process line vibration shall be provided. Exact fabrication details shall be as finalised during detailed engineering stage. The junction box for racks also shall conform to IP 65 protection class.</p> <p>Racks shall be reinforced as required to ensure true surface and to provide adequate support for instruments and equipment mounted therein. Centre posts or any member which would reduce access shall not be provided.</p> <p>Each transmitter rack housing instruments requiring purge air for continuous air purging, shall be provided with common purge air header, redundant air filter regulators of sufficient capacity, required pressure gauges, valves, fittings, SS tubings and individual purge meters for each purge line etc. as required.</p> <p>A 15 mm NB service air header shall be furnished in each rack housing air &amp; flue gas and coal mill instruments. The header shall be furnished complete with a pressure regulating valve, pressure gauge, and valve quick disconnect connections. A hose for connecting each header to the draft instrument line four-way valves shall be furnished. The hose shall be self-storing nylon tubing having a burst pressure of 15 kg/sq.cm. The size of the hose shall be 1/2" minimum. The service air header shall originate at a bulkhead penetration or fitting located on one of the bulkhead plates.</p> <p>The contractor shall prepare the piping drawings and the general arrangement layout drawings for each of the racks. Special attention shall be given in the piping layout to avoid air traps in liquid filled piping or water pockets in piping intended to be dry. Drawings shall indicate the arrangement of all equipment, piping, valves and fittings within, the racks and shall be subject to Employer's approval.</p> <p>All liquid filled blow down lines, except those measuring vacuum shall be connected to a two inch header which is extended through one end of the enclosure and turned downward for directing the blowdown into a drain. The material of the blow down header shall be carbon steel as per ASTM A 106 Gr C.</p>	

## SPECIFIC TECHNICAL REQUIREMENT

<p>KPCL/BTPS03/EPC</p> 	<p style="text-align: center;"><b>KARNATAKA POWER CORPORATION LIMITED</b></p> <p style="text-align: center;"><b>BELLARY TPS, UNIT-3 OF 700 MW</b></p> <hr/> <p>TITLE    <b>SPECIFICATIONS FOR DDCMIS/INSTRUMENTS TO BE SUPPLIED</b></p>
<p><b>30.00.00    <u>Junction Boxes:</u></b></p> <p>Wall/column mounted junction boxes having 12/24/36/48 terminals and cable entry only at the bottom and sealed with fire proof compound; Cage clamp terminals suitable for cable terminations up to 2.5 sqmm.; IP 65 or equivalent degree of protection for enclosure. Separate terminal blocks shall be used for analog and digital signal signals. Separate JBs for different voltage levels shall be supplied. Removable gland plate shall be supplied. JB shall have single lockable door with gasket, able to open side ways, with common keys. Painting inside will be glossy white &amp; outside - IS-5 shade 631. Shield bus for screw connection shall be provided. Terminal size shall be suitable for 0.5 mm<sup>2</sup> to 2.5 mm<sup>2</sup> wire. Terminal blocks shall be vertical. JB shall have provision to add 20% additional terminals. Accessories like metal tag (SS), clamps, fixtures, bolts (SS), nuts (SS), gaskets (neoprene), lock &amp; key, fire proof compound for sealing, etc. shall be supplied. The grouping of instruments in JBs is subject to Purchaser's approval. All the field Junction boxes shall have double doors. All JBs shall be provided with individual canopies to avoid ingress of water. The case, cover/door constructed from cold rolled sheet steel of 3 mm thick and shall have gland plate of 3 mm CRCA at the bottom.</p> <p><b>31.00.00    <u>Inter Posing Relays (IPR):</u></b></p> <p>Electro magnetic type IPRs with plug-in type connections, suitable for channel/rail mounting in cabinets; coil rating 24V D.C; 2 set of silver plated change over contacts rated for 0.2A 220 V DC. Free wheeling diode across relay coil(copper) and self reset type status indicator flag (electronic) shall be provided. Neon/LED indicating lamps shall be provided to indicate energise condition of relay.</p> <p>All commands to the Drives viz., Unidirectional drives, Bi-Directional drives, Solenoids and critical output contacts between systems for interlock and protection shall be through IPR. All relays shall be mounted on relay base (silver plated) internally wired to the external cabling termination block in cabinet. Wiring connection shall be screwed &amp; termination shall be suitable for 0.5 mm<sup>2</sup>.to2.5 mm<sup>2</sup> size wiring. Facility to simulate relay operation manually shall be provided. Relays of different contact interrogation voltages shall be separated by a barrier in IPR cabinet. Accessories like name plate (SS) with tag &amp; service inscription, relay base mounting rail/channel, nuts &amp; bolts, etc. shall be supplied. Three nos. change over contacts shall be wired to external TB with screwed terminations only. Status lamps shall be provided.</p>	

## SPECIFIC TECHNICAL REQUIREMENT

<p>KPCL/BTPS03/EPC</p> 	<p><b>KARNATAKA POWER CORPORATION LIMITED</b> <b>BELLARY TPS, UNIT-3 OF 700 MW</b></p> <p>TITLE <b>SPECIFICATIONS FOR DDCMIS/INSTRUMENTS TO BE SUPPLIED</b></p>	
<p><b>32.00.00    <u>System Cabinets:</u></b></p> <p>These cabinets shall house signal conditioning cards, input/output cards, processor cards &amp; associated power supply units. Indoor located, free standing vertical type system cabinets with 2 mm thick sheet metal of cold rolled steel; double doors with neoprene gaskets; keylocks; antivibration pads of 15 mm thick; Fluorescent lighting; fan in each cabinet with louvers, brass wire mesh, door switches, removable gland plate of 3 mm thick, cable glands, cubicle earthing, lifting bolt.; fire proof compound (50 mm thickness) for sealing cable entry; fire detector for each section; space heater for each section (strip type). Lamp shall be provided in each cabinet to indicate the cabinet having fault condition. The racks in system cabinets shall have provision along with plug in sockets/back plane to house at-least 20% additional cards, to accommodate for engineering flexibility or future expansion. The protection class shall be IP-32. The paint shade and thickness ..etc shall be as decided during engineering. Doors shall have concealed type of hinges and swing of 100 degrees. The doors shall be provided both at the front and rear. Power supply distribution shall be provided on per cabinet basis with all associated MCBs, protections, etc. The system cabinets, racks in system cabinets, slots in the racks &amp; the terminals shall have identification numbers. A stainless steel metal tag (plate) shall be fixed to the inside of the door &amp; the layout of the racks, slots &amp; details of the card type/service shall be inscribed on this metal tag. Each cabinet shall be provided with one each 3pin receptacles for 240 V, 1P 50 C/S. Smoke detector shall be mounted in each system panel and shall be connected to the plant Fire detection and Alarm system.</p> <p><b>33.00.00    <u>Local Panels:</u></b></p> <p>Indoor/Outdoor located, free standing vertical type local panels with 3 mm thick sheet material of cold rolled steel; antivibration pads of 15 mm thick; fluorescent lighting; Double doors with neoprene gaskets at every 1.5 m; blower &amp; louvers in each section with brass mesh; fire proof compound (50 mm thick) for sealing cable entry (bottom); fire detector for each section; space heater with thermostatic control for each section (strip type). IP 65 degree of protection for enclosure. Removable cover plates with locking facility shall be provided along the bottom of the front desk continuously to facilitate maintenance work. The length of each cover plate shall not exceed 1 m. CFL of 40 W shall be provided from one end of the panel to the other end at continuous length and shall be operated by the door switches as well as by manual switches. Name plates shall be provided for all instruments/inserts with Tag. No.&amp; short description of service engraved. These shall be phenolic overlays(1.6mmthick), black background with white lettering &amp; shall be fixed to the panel by stainless steel screws (counter sunk). Each section of the panels shall be provided with one each 3 pin receptacles for 240V, 1P 50 c/s &amp; 110 V, 1P, 50 c/s. Panel shall be delivered totally wired. All instruments, inserts and annunciation windows shall be mounted &amp; wiring connections at these hardwares shall be terminated at site by</p>		

## SPECIFIC TECHNICAL REQUIREMENT

<p>KPCL/BTPS03/EPC</p> 	<p><b>KARNATAKA POWER CORPORATION LIMITED</b> <b>BELLARY TPS, UNIT-3 OF 700 MW</b></p> <p>TITLE <b>SPECIFICATIONS FOR DDCMIS/INSTRUMENTS TO BE SUPPLIED</b></p>	
<p>vendor. Quantity shall be as required.</p> <p><b>34.00.00 <u>Vibration Monitoring System (VMS) and Analysis System.:</u></b></p> <p>34.01.01 Vibration pickups and transducers shall be provided on Y-axis for all 3.3/11KV equipments with isolated 4-20 MA DC outputs and 2 Nos. SPDT alarm contacts for high and very high condition &amp; fault for each pickup. The system shall be complete with transducers, monitors, redundant power supply, isolators mounted inside the cabinet. The sensors, mounting pads, brackets, special cables etc. shall be included.</p> <p>34.01.02 The Vibration Monitoring System shall be furnished on a system basis including vibration transducers with low noise flexible cables in flexible conduit, terminated in local terminal boxes, necessary pre-amplifier/ electronics mounted in local weatherproof boxes(IP-65) vibration monitors &amp; mounting racks/cabinets. The Vibration-monitoring system shall include all power supplies, inter-connecting cabling, calibration equipment, indicators, integrating units, signal conditioning devices and all other accessories required for monitoring of Vibration at each point. However, the finally selected sensor type shall also depend on recommendation of the equipment manufacturer &amp; suitable for application requirement.</p> <p>34.01.03 Transducers shall be furnished in weatherproof housing suitable for field conditions. Monitor shall provide vibration indication calibrated in velocity units along with provisions of changing to displacement unit (field programmable)for each measurement point in both horizontal &amp; vertical planes. The vibration monitor racks with power supplies shall be mounted in unit control panel. However, for CWP/ACWP the rack cabinet shall be located in CW pump house.</p> <p>34.01.04 The functional requirement for vibration monitoring system shall include but not be limited to the following:</p> <ol style="list-style-type: none"> <li>a. Vibration monitor front face status indications shall be available for indications of healthy conditions of pick-up circuit, monitor circuit and power supply. Also set point indication with set point adjustment facility for setting alarm &amp; trip levels shall be provided.</li> <li>b. The facility shall be available from front of mounting rack for functional checking of monitors with inhibition of alarm of alarm and trip contact outputs during test.</li> <li>c. All vibration monitoring equipment shall be functionally tested for circuit continuity and output response. All the components &amp; inter-connection cables shall be tested to ensure compliance with the specification requirements &amp; all other applicable codes and standards.</li> </ol> <p>34.01.05 For turbine and generators vibration pickups and transducers shall be provided on both X &amp; Y axis as part of turbo supervisory system. The monitoring system</p>		

## SPECIFIC TECHNICAL REQUIREMENT

	<p>KARNATAKA POWER CORPORATION LIMITED BELLARY TPS,UNIT-3 OF 700 MW</p> <p>TITLE SPECIFICATIONS FOR DDCMIS/INSTRUMENTS TO BE SUPPLIED</p>
<p>32.00.00</p>	<p><b>System Cabinets:</b></p> <p>These cabinets shall house signal conditioning cards, input/output cards, processor cards &amp; associated power supply units. Indoor located, free standing vertical type system cabinets with 2 mm thick sheet metal of cold rolled steel; double doors with neoprene gaskets; keylocks; antivibration pads of 15 mm thick; Fluorescent lighting; fan in each cabinet with louvers, brass wire mesh, door switches, removable gland plate of 3 mm thick, cable glands, cubicle earthing, lifting bolt; fire proof compound (50 mm thickness) for sealing cable entry; fire detector for each section; space heater for each section (strip type). Lamp shall be provided in each cabinet to indicate the cabinet having fault condition. The racks in system cabinets shall have provision along with plug in sockets/back plane to house at-least 20% additional cards, to accommodate for engineering flexibility or future expansion. The protection class shall be IP-32. The paint shade and thickness etc shall be as decided during engineering. Doors shall have concealed type of hinges and swing of 100 degrees. The doors shall be provided both at the front and rear. Power supply distribution shall be provided on per cabinet basis with all associated MCBs, protections, etc. The system cabinets, racks in system cabinets, slots in the racks &amp; the terminals shall have identification numbers. A stainless steel metal tag (plate) shall be fixed to the inside of the door &amp; the layout of the racks, slots &amp; details of the card type/service shall be inscribed on this metal tag. Each cabinet shall be provided with one each 3pin receptacles for 240 V, IP 50 C/S. Smoke detector shall be mounted in each system panel and shall be connected to the plant Fire detection and Alarm system.</p>
<p>33.00.00</p>	<p><b>Local Panels:</b></p> <p>Indoor/Outdoor located, free standing vertical type local panels with 3 mm thick sheet material of cold rolled steel; antivibration pads of 15 mm thick; fluorescent lighting; Double doors with neoprene gaskets at every 1.5 m; blower &amp; louvers in each section with brass mesh; fire proof compound (50 mm thick) for sealing cable entry (bottom); fire detector for each section; space heater with thermostatic control for each section (strip type). IP 65 degree of protection for enclosure. Removable cover plates with locking facility shall be provided along the bottom of the front desk continuously to facilitate maintenance work. The length of each cover plate shall not exceed 1 m. CFL of 40 W shall be provided from one end of the panel to the other end at continuous length and shall be operated by the door switches as well as by manual switches. Name plates shall be provided for all instruments/inserts with Tag. No.&amp; short description of service engraved. These shall be phenolic overlays(1.6mmthick), black background with white lettering &amp; shall be fixed to the panel by stainless steel screws (counter sunk). Each section of the panels shall be provided with one each 3 pin receptacles for 240V, IP 50 c/s &amp; 110 V, IP, 50 c/s. Panel shall be delivered totally wired. All instruments, inserts and annunciation windows shall be mounted &amp; wiring connections at these hardwares shall be terminated at site by</p>

	<p>KARNATAKA POWER CORPORATION LIMITED BELLARY TPS,UNIT-3 OF 700 MW</p> <p>TITLE SPECIFICATIONS FOR DDCMIS/INSTRUMENTS TO BE SUPPLIED</p>
	<p>vendor. Quantity shall be as required.</p> <p>34.00.00 <b>Vibration Monitoring System (VMS) and Analysis System:</b></p> <p>34.01.01 Vibration pickups and transducers shall be provided on Y-axis for all 3.3/11KV equipments with isolated 4-20 MA DC outputs and 2 Nos. SPDT alarm contacts for high and very high condition &amp; fault for each pickup. The system shall be complete with transducers, monitors, redundant power supply, isolators mounted inside the cabinet. The sensors, mounting pads, brackets, special cables etc. shall be included.</p> <p>34.01.02 The Vibration Monitoring System shall be furnished on a system basis including vibration transducers with low noise flexible cables in flexible conduit, terminated in local terminal boxes, necessary pre-amplifier/ electronics mounted in local weatherproof boxes(IP-65) vibration monitors &amp; mounting racks/cabinets. The Vibration-monitoring system shall include all power supplies, inter-connecting cabling, calibration equipment, indicators, integrating units, signal conditioning devices and all other accessories required for monitoring of Vibration at each point. However, the finally selected sensor type shall also depend on recommendation of the equipment manufacturer &amp; suitable for application requirement.</p> <p>34.01.03 Transducers shall be furnished in weatherproof housing suitable for field conditions. Monitor shall provide vibration indication calibrated in velocity units along with provisions of changing to displacement unit (field programmable) for each measurement point in both horizontal &amp; vertical planes. The vibration monitor racks with power supplies shall be mounted in unit control panel. However, for CWP/ACWP the rack cabinet shall be located in CW pump house.</p> <p>34.01.04 The functional requirement for vibration monitoring system shall include but not be limited to the following:</p> <ol style="list-style-type: none"> <li>Vibration monitor front face status indications shall be available for indications of healthy conditions of pick-up circuit, monitor circuit and power supply. Also set point indication with set point adjustment facility for setting alarm &amp; trip levels shall be provided.</li> <li>The facility shall be available from front of mounting rack for functional checking of monitors with inhibition of alarm of alarm and trip contact outputs during test.</li> <li>All vibration monitoring equipment shall be functionally tested for circuit continuity and output response. All the components &amp; inter-connection cables shall be tested to ensure compliance with the specification requirements &amp; all other applicable codes and standards.</li> </ol> <p>34.01.05 For turbine and generators vibration pickups and transducers shall be provided on both X &amp; Y axis as part of turbo supervisory system. The monitoring system</p>

## SPECIFIC TECHNICAL REQUIREMENT

	<p>KARNATAKA POWER CORPORATION LIMITED BELLARY TPS, UNIT-3 OF 700 MW</p> <p>TITLE: SPECIFICATIONS FOR DDCMIS/INSTRUMENTS TO BE SUPPLIED</p>
	<p>displayed in the form of bar charts and alarms shall be generated on occurrence of tube leakage. One speaker, power supply failure alarm and steam leak alarm shall be provided.</p> <p>The system shall be capable of operating in presence of soot blowers in operation and insensitive to the presence of nearby echo-inducing surfaces. Separately isolated 4-20mA DC analogue signals shall be provided for monitoring acoustic level for tube leaks. Bidder shall provide necessary acoustic signal generator, signal receiver, transducer with microphone, amplifier, required cables/junction box, remote control panel, 24" TFT monitor, alarm contacts to DDCMIS and all other accessories, air purging system, signal processor &amp; controller, dust, water &amp; weather proof control cabinet, connecting cables and interface to SBC system.</p> <p><b>48.00.00 Master Clock System:</b></p> <p>The existing master clock system of unit-1 shall be used for providing synchronising signal to DDCMIS. Provision of additional 20 ports and 20 nos slave display units shall be provided. The required hard ware and software including cables for connectivity from unit-1 and slave display units shall be considered.</p> <p><b>49.00.00 Control Valves:</b></p> <p><b>49.00.01</b> Multistage, anticavitation, Balanced, modulating, globe type, cage guided, single ported, diaphragm type of actuator with hand wheel, Pneumatic positioners, air filter regulator, air lock device, solenoid valve, limit switches and position transmitters completely tubed with junction box, E/P converters suitable for accepting 4-20mA DC signal. Pneumatic (copper) tubing complete with accessories, fittings, positioners shall be provided with input/output/bypass gauges. Local position indicator &amp; LVDT type position transmitter with 2 wire, 4-20mA DC output. All limit switches/position transmitters, E/P converter signals etc., shall be wired out to external block of actuator and respective junction boxes.</p> <p><b>49.00.02</b> Control valves shall be sized to have an opening of 15% at minimum flow condition and 85% at maximum flow condition. Noise level shall not exceed 85 dB at a distance of about 1.5 M from the valve. In case of predicted noise level above 85dBA, suitable low noise trim shall be provided.</p> <p><b>49.00.03</b> Leakage class for double seated valve shall not exceed 0.05%, and single seated valve shall not exceed 0.01%. Either extended type bonnet or cooling fin type bonnet shall be provided for service above 200°C and for other service the bonnet type shall be standard.</p> <p><b>49.00.04</b> The end connections shall be socket welded for sizes below 50 NB and butt</p>

	<p>KARNATAKA POWER CORPORATION LIMITED BELLARY TPS, UNIT-3 OF 700 MW</p> <p>TITLE: SPECIFICATIONS FOR DDCMIS/INSTRUMENTS TO BE SUPPLIED</p>
	<p>welded for sizes 50 NB and above. Flanged connection shall be provided for DM water services, with suitable rubber lined interfaces. Water seal shall be provided for valves that could be subjected to below atmospheric conditions.</p> <p><b>49.00.05</b> Generally stem and guide material(trim) shall be SS 316 sterlited, and plug and seat material will be 17-4 PH SS, except for specific applications like DM water, HP bypass services. Refer to Table-5 for selection of control valve body material and actuator type. The noise abatement shall be obtained by valve body and trim design and not by use of silencer. The trims supplied shall be suitable for quick changing. Actuator housing shall be of pressed steel construction.</p> <p><b>49.00.06</b> In Vibration prone areas, positioners shall be located away from the control valve/damper and location shall be approved by OWNER/ENGINEER. Position transmitter shall be non-contact type.</p> <p><b>49.00.07</b> The control valve design shall be suitable for the required fail-safe conditions, of process / equipment. The valves shall be supplied and commissioned as per the fail-safe philosophy required for the process. Whenever the required shutdown is not possible with a standard single valve, specially designed trims shall be customised and used. Pressure regulators upstream of control valves would not be envisaged.</p> <p><b>49.00.08</b> All final Control elements (Control valves &amp; control dampers) shall be with pneumatic or electric actuators. All actuators would be sized so that the final control elements operate properly even when the upstream pressure exceeds 110% of maximum value. Pneumatic actuators would be provided with air failure lock and remote release, limit switches, adjustable in/minimum and maximum stops, load position indicators, positioners, non-contact type electronic position transmitters and solenoid valves in accordance with the system requirements.</p> <p><b>49.00.09</b> SMART positioners shall be provided for all pneumatic operated control valves/dampers. For the services in heat prone area Integral type positioners shall be offered.</p> <p>The type of actuator shall be pneumatic type except Governing valves, HPLP bypass services for which hydraulic actuator shall be used.</p> <p><b>50.00.00 (50.00.01)</b> <b>Programmable Logic Controllers (PLC):</b> For systems mentioned in Table-1: The microprocessor shall be based on 32 bit processing. The programme memory shall be non volatile memory. The PLC shall perform protection logic, interlock and sequential control functions such as binary logic operation, set/rest operation, timers, counters, logic blocks, maths functions, boolean functions &amp; timer functions. PLC shall complete with processor, I/O cards, memory modules, racks, monitoring accessories. The scan time for digital inputs shall not be more than 60msec and execution 120msec. The system shall be loaded to maximum 60% under worst loading conditions.</p>

## SPECIFIC TECHNICAL REQUIREMENT

 KPCL/BTPS03/EPC	KARNATAKA POWER CORPORATION LIMITED BELLARY TPS, UNIT-3 OF 700 MW TITLE: SPECIFICATIONS FOR DDCMIS/INSTRUMENTS TO BE SUPPLIED
<p>50.00.02 The redundant processors, redundant communication cards, redundant bus, redundant Power Supply cards for PLC system shall be considered. Further, I/O cards shall be redundant for critical inputs and outputs used for protection, interlock &amp; commands for critical services.</p> <p>50.00.03 The system shall have self diagnosis features. The operation, monitoring and programming shall be performed from the MMI Monitor station. The system shall be connected to DCS using hot redundant bi-directional OPC communication link and shall have time synchronisation with master clock system. The required hardware for this connectivity shall be included.</p> <p>50.00.04 Independent redundant UPS with 1 hour Battery back up shall be provided for each of local PLC systems. PLC system with MMI, laser printer shall be included. For PLC system with out MMI OWS, a hand held programmer shall be provided.</p> <p>50.00.05 Input/Output Modules as required in the control system for all type of field input (4-20 mA, RTD, T/C, Digital contacts etc.) and output from the control system are to be provided as per requirement. Electrical isolation for 1.5 KV with optical coupler between the plant put/output and surge protection as per IEEE 472. The hardware design shall be such that it is able to withstand power line disturbance. The system shall conform to ANSI/IEEE C 62.4 (Immunity to power supply line disturbance).</p> <p>50.00.06 Bidder shall provide at least 20% wired spare capacity of input/output modules over and above the system requirement. Bidder shall provide built in diagnostic for easy fault detection.</p> <p>50.00.07 System shall be able to operate in non air conditioned area. However where PLC panels/ I-O racks are located at local areas in dusty and hot zone (AHS &amp; CHS) PLC panels/I-O racks shall be provided with air condition with suitable protection class. Ash handling and Coal handling control room will be air conditioned. Bidder may provide Annunciation System as integral part of PLC. Field contacts shall be acquired through PLC only. The Annunciation sequence logic shall be implemented as a part of PLC controllers. The No. of Annunciation facia windows and provision of original input will be on as required basis.</p> <p>50.00.08 For coal handling and Ash handling control systems, where a Large Video Screen display system is to be provided, shall be suitably integrated with PLC control system</p> <p>Bidder shall provide electronic grounding for PLC which shall be separate from Electrical grounding as per IS or IEEE Standard.</p>	

 KPCL/BTPS03/EPC	KARNATAKA POWER CORPORATION LIMITED BELLARY TPS, UNIT-3 OF 700 MW TITLE: SPECIFICATIONS FOR DDCMIS/INSTRUMENTS TO BE SUPPLIED
<p>50.00.09</p> <p>50.00.10</p> <p>51.00.00</p> <p>51.00.01</p> <p>51.00.02</p> <p>51.00.03</p> <p>51.00.04</p> <p>51.00.05</p>	<p>The Factory Acceptance Test for PLC system shall consist of a) Hardware &amp; Software as per BOM b) Spare capacity in cabinet for new module c) Current &amp; Power Consumption d) Power Failure Test e) Healthiness of Hardware/all module f) On line removal of I/O card g) Accuracy Test h) Diagnostic Test i) Functional Test j) Verification of Software k) Redundancy Test of Controller l) Redundancy Test of power supply m) CPU loading duty cycle n) Power failure auto restart. Any other Test as per QAP. The Type test reports also shall be submitted for review.</p> <p><b>Essential Spares:</b> Bidder shall include 10% or 1 No ( whichever is higher) each type of module, which shall include controller card, Communication card, Input, Out put card, Power Supply card/Unit, Relays, push buttons, lamps, etc</p> <p><b>Instrumentation Cable Specifications:</b></p> <p>All the instrumentation cables i.e. twisted and shielded multipair cables, compensating cables, pre fabricated cables etc. shall be flame retardant low smoke (FRLS) type. All the cables shall be armoured.</p> <p>The cables shall be provided in non returnable drums. The drum length shall be 1000 m (+/- 5%) and 500 m (+/- 3%) except for the last drum or if the ordered quantity itself is less than 500 mtrs. The cables covered under this specification shall be suitable for crimping, screw termination or cage clamp type screw less terminals blocks.</p> <p>All instrumentation cables covered in this specification shall comply with Latest Edition of following standards along with the amendments shall be referred for manufacturing these cables: VDE 0815, VDE 0207 Part-4, Part-5, DVE 0816, VDE 0472, ANSI-MC 96.1, IS-5831, IS 10810, IS-5784, IS-3975, ASTM-D-2863 &amp; 2843, IEC-754-1, IEEE-383, SEN 4341475. Voltage grade of the instrumentation cables shall be 600 V (peak value).</p> <p>The conductor shall be of minimum 70/3.0.5 Sq.mm size, high conductivity, multi-stranded copper for all types of instrumentation cables, except the thermocouple extension cables which shall be 1.31 mm Sq. solid alloy type.</p> <p>The insulation of individual conductor shall be extruded PVC- Y (Meeting the requirements of VDE 0207 part 4. The inner and outer sheath of cables shall be extruded PVC type YM-1 as per VDE 0207 part 5 and shall be flame retardant low smoke type (FRLS). The thickness of inner sheath (inner sheath only for armoured cables) shall be 0.3 mm minimum and the outer sheath shall be as per the guidelines given in VDE 0816, however the thickness of outer sheath shall not be less than 1.8mm in any case. Insulation thickness over conductor shall be 0.4 mm nominal. Allowable tolerance of overall diameter of the cable shall be 2mm max. over the declared value in technical data sheet. The variation in diameter and the ovality at any cross section shall not be more than 0.1 mm.</p>



TITLE:

**TECHNICAL SPECIFICATION FOR  
OZONE GENERATION PLANT**

**1X700 MW BELLARY THERMAL POWER  
STATION UNIT NO. 3, STAGE-3**

BHEL DOCUMENTS NO.: PE-TS-367-174-14000A-A001

VOLUME **II-B**

SECTION -D

REV. NO. 01

DATE: 24/02/2014

### **GENERAL TECHNICAL REQUIREMENT**

**D1: GENERAL TECHNICAL REQUIREMENTS FOR MECHANICAL**

**D2: GENERAL TECHNICAL REQUIREMENTS FOR ELECTRICAL**

**D3: GENERAL TECHNICAL REQUIREMENTS FOR C&I**



**TITLE:**

**TECHNICAL SPECIFICATION FOR  
OZONE GENERATION PLANT**

**1X700 MW BELLARY THERMAL POWER  
STATION UNIT NO. 3, STAGE-3**

BHEL DOCUMENTS NO.: PE-TS-367-174-14000A-A001

VOLUME **II-B**

SECTION -D1

REV. NO. 01

DATE: 24/02/2014

**SECTION-D1**

**GENERAL TECHNICAL REQUIREMENT-MECHANICAL**



TITLE:

TECHNICAL SPECIFICATION FOR  
OZONE GENERATION PLANT1X700 MW BELLARY THERMAL POWER  
STATION UNIT NO. 3, STAGE-3

BHEL DOCUMENTS NO.: PE-TS-367-174-14000A-A001

VOLUME **II-B**

SECTION –D1

REV. NO. 01

DATE: 24/02/2014

**1. DESIGN CRITERIA:**

Ozone treatment is to be done for Cooling Water to prevent growth of biological substances. Ozone generation plant shall comprise of the Ozone generating system including mixing device, ozone generators, its feed gas preparations device & its controls. Ozone shall be generated using a dry filtered gas containing oxygen, which is fed through an electrical discharge created between the two electrodes. The discharge, known as “silent corona discharge” causes the dissociation of some of the oxygen molecules resulting into the formation of ozone. The produced ozone gas is mixed with water and resulted ozonized water is dosed into the Condenser inlet and outlet. The ozone concentration shall be of 8-10% (W/W). The design pressure of all the pressure vessels shall be 8kg/cm<sup>2</sup> (g) minimum.

The ozone generation plant shall consist of at least the following sub systems:

- OXYGEN GENERATION PLANT
- OZONE GENERATION PLANT
- COOLING WATER PLANT
- OZONE DOSING SYSTEM
- MEASURING & MONITORING DEVICES
- PLC BASED CONTROL SYSTEM

The brief description of above mentioned sub systems are as follows:

- **OXYGEN GENERATION PLANT-** Oxygen generation plant is used to feed desired quantity & quality of feed gas to Ozonator. It shall consist of following equipments:
  - **Compressor:** Three numbers (2 Working +1 Standby) screw type air cooled compressors of suitable capacity along with electrical motor, instruments, ducting arrangement, valves, piping shall be provided by the bidder.
  - **Air Receiver:** One number air receiver shall be provided by the bidder along with all the accessories. The capacity of air receiver shall be 3.0 M<sup>3</sup> (minimum).
  - **Dryer Unit:** Two numbers (2X100%) Dryer unit per stream (total 4 numbers for both the streams) along with all the accessories shall be provided by the bidder to remove the moisture from the air. The dryer shall be based on adsorption phenomenon using activated alumina or equivalent material based on supplier recommendations.
  - **Oxygen generator:** Two numbers (2X100%) oxygen generator / concentrator per stream (total 4 numbers for both the streams) along with all the accessories to achieve the pure oxygen shall be provided by the bidder. Online measurement & monitoring facilities of oxygen purity & dew point shall also be provided by the bidder.
  - **Oxygen receiver:** Two nos (2x50%) oxygen receiver shall be provided by the bidder along with all the accessories. The capacity of each oxygen receiver shall be 2.5 M<sup>3</sup> (minimum).
- **OZONE GENERATION PLANT-** Ozone generator shall be vertical/horizontal shell and tube, corona discharge, water cooled, fixed voltage and variable frequency type. Ozone shall be generated by passing oxygen through a gap formed between power connection and SS tube. Ozone production shall be controlled by varying the applied frequency. However the design and configuration of ozone generator shall be purely supplier specific.
  - **Ozone electrode:** Ozone generating module shall be a modular vertical tubular form of MOC SS316 L or better based on supplier recommendations.
  - **Dielectric glass tube:**
    - A. **Material :** Borosilicate glass/ equivalent based on supplier recommendations
    - B. **Type:** Cylindrical.
    - C. **Construction:** Closed at one end.
- D. **COOLING WATER PLANT:** Cooling water plant is provided for removal of excess heat generated during ozone generation from ozone producing cells. Suitable capacity two numbers (2X100%) air cooled Chillers for removal of excess heat generated during ozone generation from ozone producing cells shall be provided by the bidder. Ozone system shall be water cooled. Potable water is used for removal of excess heat from the ozone producing cells. The water analysis of potable water has been attached as Annexure – II elsewhere in the specification.



**TITLE:**  
**TECHNICAL SPECIFICATION FOR  
 OZONE GENERATION PLANT**

**1X700 MW BELLARY THERMAL POWER  
 STATION UNIT NO. 3, STAGE-3**

BHEL DOCUMENTS NO.: PE-TS-367-174-14000A-A001

VOLUME **II-B**

SECTION –D1

REV. NO. 01      DATE: 24/02/2014

- **OZONE DOSING SYSTEM:** Ozone produced from ozone producing cells is mixed with water. This system consists of venture injection to contact the ozone with the cooling water. The water flow through the injector produces a partial vacuum which is utilised to draw ozone into the water stream and mix the two phases vigorously. The water jet exiting the injector with great turbulence from the motive nozzle disperses the gas into a stream of finest bubbles. This action increases the contact surface between gas and water phases tremendously which is essential for optimized mass transfer. The ozonated water will be introduced into the inlet & outlet to condenser. Static mixtures shall also be provided for the ozone dosing line at the interval of 20 meters. However minimum number of Static mixtures shall be 15 numbers.

• **MEASURING & MONITORING DEVICES:**

Following minimum number of measuring and monitoring devices shall be provided by the bidder

- Outlet ozone gas of each ozone-generating module shall be measured by one number (minimum) common ozone analyser.
- One number (minimum) ambient ozone leak detector shall be placed in the ozone generator room to detect ozone leakage with alarm and cut-off signal on set value.
- One number (minimum) Residual Ozone analyser at the condenser outlet.
- O<sub>3</sub> Concentration indicator at the outlet of each Ozone generator.
- One number (minimum) ozone gas destructor (if applicable).

**2. CAPACITY SELECTION:**

Total CW Flow	=	82109 m <sup>3</sup> /hr
Ozone dosing rate	=	0.2 ppm
Ozone requirement	=	16.42 Kg/Hr.
Ozone Dosage rate selected	=	18 Kg/hr.
Nos of ozone generator	=	N (Working)+0(Stand by) *
Capacity of each ozone generator	=	Supplier Specific *

\*The numbers of ozone generator and capacity of ozone generator shall be supplier specific.

**3. PLANT OPERATION AND CONTROL**

The operation of the Ozone generation Plant shall be from PLC based complete automatic control system. It shall be possible to operate the plant in Auto / Semi auto / Manual mode. In 'Auto mode, once the sequence has been initiated, it shall proceed from step to step automatically. In 'Semi auto' mode each step shall be performed only after initiation by the operator. In 'manual' mode complete operation shall be by the operator. However the detailed control shall be furnished by the bidder during detailed engineering stage.

Alarm windows and No. of alarm shall be finalised during detail engineering.

UPS: PLC shall be powered from 2x100% parallel redundant UPS Power supply with 60 minutes battery back-up.

Dual redundant measurements shall be envisaged for CLCS / OLCS functions and Single measurements are envisaged for monitoring.

Soft signal exchange between Ozone PLC and main plant DCS is only envisaged & for monitoring of critical parameters

All the pumps/compressors /heat exchanges shall have inlet and outlet process measurement at locals as well as in remote (PLC-OWS).

All the valves coming in sequence shall be automatic valves.

Following minimum alarms shall be provided:

- High gas exit temperature
- High or low gas pressure
- Low chilled water flow
- High chilled water exit temperature
- Frequency drive failure



**TITLE:**  
**TECHNICAL SPECIFICATION FOR  
 OZONE GENERATION PLANT**  
  
**1X700 MW BELLARY THERMAL POWER  
 STATION UNIT NO. 3, STAGE-3**

BHEL DOCUMENTS NO.: PE-TS-367-174-14000A-A001  
**VOLUME II-B**  
 SECTION –D1  
 REV. NO. 01      DATE: 24/02/2014

- Loss of phase detect
- High inverter current trip
- Low feed gas flow
- Door interlock trip
- Ozone concentration (intermittent)
- ORP/ residual ozone

**4. LAYOUT CONSIDERATIONS**

- Ozone generation plant will be located indoor in a separate building as indicated in the drawing number PE-DG-367-100-M003 REV 04, T.G. EQUIPMENT LAYOUT PLAN AT EL 0.0 M . The maximum space available for complete ozone generation plant is 22.5 meters X 12meters. Bidder to accommodate entire ozone generation plant within this space. All the arrangements for the same is in bidder's scope.
- The air receivers will be located outdoors adjacent to the Ozone generation plant building.
- Complete Air Drying Plant and Oxygen generation plant equipment shall be mounted on a skid and located indoor.

**5. VENTILATION CONSIDERATION:**

- Rooms where ozone might be emitted in case of failure shall be effectively monitored by gas detectors with alarms that stop the generation of ozone when activated. Effective monitoring means are the gas detector sensors. Rooms with ozone generators shall be equipped with ventilation actuated automatically by the gas detectors. The number of air changes per hour shall be as follows:

S.No.	Area	Inside Condition	Type of Ventilation	AIR CHANGE PER HOUR (ACPH)
1.	MCC Room	Inside temperature not exceeding 3°C above outside dry bulb temperature.	Supply air through axial fan filter unit and exhaust through gravity damper.	20
2.	All toilets, pantries.	Inside temperature not exceeding 3°C above outside dry bulb temperature.	Mechanical ventilation with propeller type exhaust fan.	20
3.	Battery and battery charger room	Inside temperature not exceeding 3°C above outside dry bulb temperature.	Negative pressurization of 5 mm by means of axial flow exhaust fans with flameproof motors.	30
4.	Compressor House	Inside temperature not exceeding 3°C above outside dry bulb temperature.	Supply air through axial fan filter unit and exhaust through axial exhaust fan.	15
5.	Ozone building	Inside temperature not exceeding 3°C above outside dry bulb temperature.	Mechanical exhaust by means of axial flow exhaust fans	15

➤ **DESIGN CRITERIA**

The outside design conditions considered are as follows:

	Summer	Monsoon	Winter
DBT (°C)	42	34.4	18.3
WBT (°C)	25.0	25.6	15.0



**TITLE:**  
**TECHNICAL SPECIFICATION FOR  
 OZONE GENERATION PLANT**

**1X700 MW BELLARY THERMAL POWER  
 STATION UNIT NO. 3, STAGE-3**

BHEL DOCUMENTS NO.: PE-TS-367-174-14000A-A001

VOLUME **II-B**

SECTION –D1

REV. NO. 01      DATE: 24/02/2014

- All Ventilation equipment's shall be designed for continuous duty & shall operate on 100% fresh air basis.
- The ducting shall be sized to have constant friction drop along its length with air velocity in the ducts normally not exceeding 12 m/sec for ventilation system.
- All air conditioning and ventilation systems etc. are in bidder's scope.

**6. AIR-CONDITIONING CONSIDERATION:**

Split type air conditioners (air cooled) with necessary MCBs , shall be provided to cater to the air conditioning requirements of PLC area. These air-conditions shall be operated with Push Button Station / Remote type. The configuration of the air conditioners shall be N(Working) +1 (standby). Minimum capacity and rating of each air conditioner shall be 1.5 TR & 4 star respectively. Heat load calculation for the air conditioning area shall be as per ISHRAE guideline.

**7. DESIGN REQUIREMENT FOR PIPING:**

- ❖ Sizes of pipelines shall be selected such that the velocity of fluid in pipes does not exceed the following limits under conditions of maximum possible volumetric flow:

<b>Water</b>	
Pump suction	1.5 m/s
Pump delivery	3.0 m/s
Service/Potable water	1.5 m/s
<b>Gas</b>	
Compressed air	15 m/s

- ❖ Drain and vent connections on pipelines shall be atleast of NPS 25 mm size.

- ❖ UNDERGROUND PROTECTION

- Where pipelines are buried, underground protection shall be provided by the bidder for the piping system as indicated any one of the methods given below:
  - (a) Coal tar primer, coal tar enamel, inner wrap of fibre glass, final outer wrap of enamel impregnated fibre glass. Total thickness of coating shall not be less than 4.0 mm.
  - (b) With anti-corrosive tape of 4 mm thick conforming to IS-10221 and AWWA C 203-93.
    - Pipe surfaces shall be cleaned by shot or sand blasting before application.
    - Tests to be carried out after application
      - (a) Bond/Adhesion test
      - (b) Holiday test

**8. DESIGN REQUIREMENT FOR VALVES:**

- ❖ All gate and globe valves shall be of rising stem, outside screw and yoke type.
- ❖ Check valves of sizes 400 mm NB and larger shall have dash pot arrangement.
- ❖ All gate and globe valves shall have back-seating arrangement to facilitate easy replacement of packing with the valve in service.
- ❖ All valves shall be so designed that the hand-wheel moves in a clockwise direction to close the valve. The face of the hand-wheel shall be clearly marked with the words 'OPEN' and 'CLOSE' and an arrow to indicate the direction for opening. All hand-wheels shall be fitted with name plate.
- ❖ All gate, globe, Y-type and angle valves intended for manual operation and falling under the following categories shall be equipped with a gear operator for ease of operation and to ensure fast and tight closure:

<b>ANSI PRESSURE RATING</b>	<b>VALVE SIZES FOR WHICH GEAR OPERATOR IS REQUIRED</b>
Class 300 and below	350 mm and larger
Class 600 and above	200 mm and larger

- ❖ All gate valves falling in the following categories shall be provided with integral bypass valve. Bypass size shall conform to MSS-SP-45 as a minimum standard unless otherwise specified. The bypass valve shall be hand



**TITLE:**  
**TECHNICAL SPECIFICATION FOR  
 OZONE GENERATION PLANT**

**1X700 MW BELLARY THERMAL POWER  
 STATION UNIT NO. 3, STAGE-3**

BHEL DOCUMENTS NO.: PE-TS-367-174-14000A-A001

**VOLUME II-B**

**SECTION –D1**

REV. NO. 01      DATE: 24/02/2014

operated unless otherwise specified. Pipe for bypass shall be at least Schedule 80 seamless and of a material of the same nominal chemical composition and physical properties as that used for the main line. Orientation of bypass arrangement shall be subject to the approval of BHEL/Customer.

<b>ANSI PRESSURE RATING</b>	<b>VALVE SIZES FOR WHICH BYPASS IS REQUIRED</b>
Class 600 and over	200 mm and larger
Class 300 & 150	350 mm and larger

- ❖ All gate valves of ANSI pressure rating class 150 and 300 shall have solid or flexible wedge and ANSI pressure rating class 600 and above shall have flexible or parallel slide type of wedge.
- ❖ Valves that are to be kept in full 'OPEN'/'CLOSE' position shall be provided with a non-detachable locking arrangement.
- ❖ Valves operating under vacuum conditions shall have glands with water sealing. The inlet and outlet connections shall be NB 15mm. The bidder shall indicate the maximum and minimum sealing water pressure and the required flow rate.

**9. DESIGN REQUIREMENT FOR HORIZONTAL CENTRIFUGAL PUMPS**

- ❖ Flow rate versus head curve shall have a stable and continuously rising characteristics towards the shut-off head. In case of unstable (drooping) characteristics the duty point shall be well away from the unstable region. Besides the actual flow rate versus head curve, curves for minimum and maximum impeller diameters shall also be shown.
- ❖ The shut-off head shall be at least 110% of the differential head.
- ❖ The required NPSH at duty point shall be at least one (1) metre less than the available NPSH.
- ❖ The rating of the pump driver shall be the larger of the following:
  - (a) The maximum power required by the pump from zero discharge to run-out discharge at site climatic conditions.
  - (b) 110% of the power required at the duty point at site climatic conditions.
- ❖ The corrosion allowance for pressure parts shall be 3 mm.
- ❖ Pumps shall run smooth without undue noise and vibration. Noise level produced individually or collectively shall not exceed 85 dB(A) measured at a distance of 1.0 metres from the source in any direction. The overall vibration level shall be as per zones A and B of ISO 10816-1.
- ❖ Bearing shall be oil-lubricated or grease-lubricated and shall have a life of 40,000 hours of working. In case of oil-lubricated bearing, constant oil leveller with magnetic drain plug shall be provided.
- ❖ For all pumps while calculating the pump head, 20% margin (minimum) shall be considered on the value of friction losses. The static head shall be considered based on the pipe routing, however it shall be minimum 15 m.

**10. DESIGN CONSTRUCTION OF AIR COOLED SCREW COMPRESSORS**

- ❖ Each compressor will be designed to deliver the nominal capacity at the required delivery pressure.
- ❖ Air compressors will be multi stage oil free, screw type, air cooled.
- ❖ Testing of compressor will be as per ISO: 1217.
- ❖ Air compressors will be designed for continuous operation with high efficiency to satisfy the performance requirement.
- ❖ The continuous motor rating will be at least ten percent (10%) above the maximum load demand of the driven equipment under the entire operating range. When the driver is not directly coupled to the compressor, due consideration will be made for losses in power transmission, in addition to the above margin.
- ❖ Satisfactory operation in parallel will be ensured without any uneven load sharing, undue vibration, noise etc.
- ❖ Noise level shall not exceed 85 dBA plus tolerances as per IS standard to a reference level of 0.0002 microbar when measured at a distance of 1.5 meter above the floor. Required acoustic enclosures have to be provided to meet the above condition. The discharge blow off silencer and intake silencers shall be designed to meet the above noise limitation level.
- ❖ Compressed air velocity shall be 10 m/sec.
- ❖ Air ducting arrangement for each compressor shall also be provided by the bidder.
- ❖ **ROTORS**
  - Rotors will be one-piece construction with a suitable forged carbon steel or stainless steel coated with corrosion resistant material to minimize leakage and wear.
  - The rotors will have an asymmetric profile, so as to keep leakage losses to a minimum and ensure high efficiency.
  - Highly precise timing gears will be mounted on the rotor shafts to maintain the rotors in correct relative position.
  - These gears will be designed to counteract the axial forces incurred in compression.
  - Rotors shall be dynamically balanced.
- ❖ **INTAKE FILTER**



**TITLE:**  
**TECHNICAL SPECIFICATION FOR  
OZONE GENERATION PLANT**  
  
**1X700 MW BELLARY THERMAL POWER  
STATION UNIT NO. 3, STAGE-3**

BHEL DOCUMENTS NO.: PE-TS-367-174-14000A-A001	
VOLUME <b>II-B</b>	
SECTION –D1	
REV. NO. 01	DATE: 24/02/2014

- Dry type suction air filters will be provided at the compressor inlet to prevent dust and dirt from entering the cylinders. The filtering efficiency shall be 99.9 %, down to 03 microns. Sound suppressing characteristics will be considered in the filter design.

## 11. PG TEST PROCEDURE

The PG Test Procedure shall cover the test to be conducted at site for the entire system / sub-systems and individual equipment covered in Ozone Generation Plant and shall include at least Ozone Generators, Compressors, Air receiver, Oxygen generators, Air driers, oxygen receivers, chillers, all pumps, atmospheric tanks, analyzers, air conditioning and ventilation system, electric hoist all piping and valves, Electrical and Electronic controls including PLC etc.

**11.1 Objective of the Test:** The following minimum objectives will be checked:

- To check healthy working of all the equipment forming the total Ozone Generation Plant.
- To check the total power consumption of the Ozone Generators, Compressors, Driers, Oxygen generators, pumps etc at rated capacity of the respective equipment.
- To check the capacity of the Ozone generators, Oxygen generators, capacity and head Compressors, pumps etc.
- To log the operating parameters of the Ozone Generators and Compressors with online calibrated instruments at the time of capacity test. Separate calibrated instruments can also be used to measure the parameters other than online instruments
- To check satisfactory operation of all interlock protection devices, trace Ozone analyzers, Oxygen purity analyzer, dew point transmitter, residual ozone analyser etc.
- To measure the purity of the Oxygen and ozone gas.

**11.2 Condition of conductance of Test:**

- PG Test at site shall be conducted by accredited representatives of bidder and witnessed by BHEL and customer. The Bidder shall inspect the entire system in advance and make it ready for the test. The Bidder's representative shall conduct and/or witness and associate with all the phases of the test and record the data jointly with BHEL & the Customer representatives.
- The entire responsibility for conducting the test rests with the bidder.

**11.3 Test Instruments:**

- All instruments required for PG Test as per objective of the test is in bidder's scope. Online instruments installed in the system shall be used for majority of readings. In case any offline instruments are required, the same shall be provided by the bidder free of cost on returnable basis.
- Calibration of all the test instruments (installed online instruments and offline instruments) shall be the responsibility of the bidder.
- Calibration of all the instruments shall be carried out within a period of six months preceding the commencement of test.
- Calibration certificates of all the instruments shall be submitted by bidder for BHEL & Customer approval at least 15 days before the start of PG Test.
- The instruments to be arranged by the bidder shall however not be limited to those listed above and any other instrument / apparatus required for successful conduction of PG Test as per the objectives of the test shall also be arranged by the bidder free of cost.



**TITLE:**  
**TECHNICAL SPECIFICATION FOR  
OZONE GENERATION PLANT**  
  
**1X700 MW BELLARY THERMAL POWER  
STATION UNIT NO. 3, STAGE-3**

BHEL DOCUMENTS NO.: PE-TS-367-174-14000A-A001	
VOLUME <b>II-B</b>	
SECTION –D1	
REV. NO. 01	DATE: 24/02/2014

**12. PG test procedure:**

The PG Test of all Ozone Generators and Compressors and their associated equipments shall cover mainly following tests:

- Capacity test (NM3/Hr) of electrolysers, compressors, Oxygen generators, air driers, pumps, chiller etc.
- Checking the ability of electrolysers, compressors, Oxygen generators, air driers, pumps, chiller etc. to operate continuously at rated capacity and rated discharge pressure.
- Measurement of Oxygen purity at oxygen generator outlet.
- Measurement of Ozone purity at Ozone generator outlet.
- All interlocks & logics functioning as per approved interlock logic diagram.
- Parallel operations of streams.
- Noise level and vibration of compressors.
- Power consumption.
- Ozone dosing and its effectiveness in the Cooling water.

Note: The above mentioned PG test requirements are bare minimum. However any comments/requirement as required by BHEL/Customer during detailed engineering stage shall be provided by successful bidder without and price and delivery implication to BHEL.

**13. SPARES:**

13.1 The Bidder shall include in his scope: (a) Start-up / commissioning spares as necessary and (b) A detailed list of recommended spares shall also be furnished by the Bidder.

13.2 The spares (both start up and essential spares) shall be delivered at the site well in time before the start up and commissioning of the plant.

**13.3 Start Up Spares**

Start up spares (also termed as 'commissioning spares') are those spares which will be required during the start-up and commissioning of the equipment / systems and until performance testing. It is the responsibility of the Bidder to supply all necessary spares as required until the equipment / systems are handed over to the Customer. The prices of the start up spares should be included in the price of the package. An adequate stock of start-up spares shall be made available at the site such that the start-up and commissioning of the equipment / systems, performance testing and handing over the equipment / systems to the Customer can be carried out without hindrance and delay.

**13.4 Recommended Spares**

In addition to the spares mentioned above, the Bidder shall also furnish in the Schedule of Recommended Spares a list of recommended spares parts for three (3) years normal operation with unit prices. These recommended spares shall be those considered necessary by the Bidder on a stand alone basis. The BHEL reserves the right to buy any of the recommended spare parts as considered necessary by him. The prices of recommended spares shall be consistent with those of the commissioning spares.



TITLE:

**TECHNICAL SPECIFICATION FOR  
OZONE GENERATION PLANT**

**1X700 MW BELLARY THERMAL POWER  
STATION UNIT NO. 3, STAGE-3**

BHEL DOCUMENTS NO.: PE-TS-367-174-14000A-A001

VOLUME **II-B**

SECTION -D1

REV. NO. 01

DATE: 24/02/2014

## GENERAL TECHNICAL REQUIREMENTS FOR ELECTRIC HOIST



TITLE:  
**TECHNICAL SPECIFICATION FOR  
 OZONE GENERATION PLANT**  
  
**1X700 MW BELLARY THERMAL POWER  
 STATION UNIT NO. 3, STAGE-3**

BHEL DOCUMENTS NO.: PE-TS-367-174-14000A-A001  
**VOLUME II-B**  
 SECTION -D1  
 REV. NO. 01      DATE: 24/02/2014

**1.0 GENERAL**

Specification cover the design, material, construction features, manufacture, inspection, testing the performance at the vendor's/sub-vendor's works, delivery to site, erection, commissioning and testing of Electric hoist.

**2.0 GENERAL DESIGN FEATURES**

- Bidder shall provide Electric hoists to facilitate the lifting and transporting of various pieces of equipment during construction, maintenance, or replacement of the Ozone generation plant components.
- The electric hoist shall be complete with its accessories, supporting structure, power supply, safety devices, and controls and shall conform to local statutory rules and regulation.
- Equipment offered shall be conforming to specification requirements as per IS: 3938 class II duty.
- Parts requiring replacement or lubrication shall be easily accessible & without dismounting type.
- Equipment shall include the devices as required and comply with applicable standards/specification requirements.
- Defects in material not acceptable/allowed. Rectification of any flaw is permissible only with the approval of BHEL.
- Design shall provide for easy maintenance of all parts, particularly the wheel bearings.
- Both hoists and trolleys are driven electrically as specified
- Wheels shall be single flanged type and to suit different monorail beam sizes
- Hook shall be swiveling type and fitted with a safety latch.
- Hoists shall be designed for minimum headroom above the highest position of hook and for closest hook approaches.
- All material, castings and forgings will be of tested quality & certificates shall be made available for approval as per approved QAP.
- Creep speed shall be provided for hoisting motion only and shall be through VVVF drive.

**Electric Hoist**

S.No.	DESCRIPTION	TECHNICAL PARTICULARS	
1.0	<b>Type</b>	Steel wire electric hoist with electrically operated trolley	
2.0	<b>Overload test</b>	125% of SWL	
3.0	<b>Design Ambient temperature</b>	50 ° C	
4.0	<b>General Design</b>	As per IS: 3938 / 1983, class-II	
5.0	<b>Operating speed</b>	Full speed (m/min)	Creep speed (m/min)
5.1	Hoisting speed	3.0 M / min.	10% of main speed (thro' VVVF drive)
5.2	Trolley speed	10.0 M / min.	NA
6.0	<b>Type of transmission</b>	Through Electric motor and gearbox	
7.0	<b>Wire Rope</b>	Min ultimate tensile strength = 180 kg/mm <sup>2</sup>	
7.1	Construction / core	6 x36 Steel core	



TITLE: <b>TECHNICAL SPECIFICATION FOR          OZONE GENERATION PLANT</b>  <b>1X700 MW BELLARY THERMAL POWER          STATION UNIT NO. 3, STAGE-3</b>	BHEL DOCUMENTS NO.: PE-TS-367-174-14000A-A001	
	VOLUME <b>II-B</b>	
	SECTION -D1	
	REV. NO. 01	DATE: 24/02/2014

7.2	Code	IS:2266
7.3	Factor of safety	Not less than 5
7.4	No. of full laps on the drum at extreme low position of hook	Rope shall be of sufficient length so that 3 (three) full laps remain on the drum at extreme low position of the hook not taking into consideration the turns covered by the wore rope anchorage and one spare groove for each lead of the wire rope on the drum when hook is at its highest position.
8.0	<b>Load Hook and block</b>	
8.1	Type of load hook	Plain shank type swiveling with safety latch (section: circular/ trapezoidal/'c' type)
8.2	Load hook Code	IS:15560
8.3	Load hook Material	As per IS: 1875, min. C 20 forged
8.4	Hook suspension	Thrust bearing
9.0	<b>Gear (Hoisting)</b>	
9.1	Type	Spur / Helical
9.2	Material	Gear: 16 Mn Cr 5 / 20 Mn Cr 5 / C40 / C50 / EN19 / EN24 / SAE 8620 / 16 Cr Ni 4 / 18 Ni Cr Mo5 / 39 Ni Cr. MO3 / 42 Cr MO4
9.3	Bearing type	Antifriction Ball
10.0	Trolley drive	
10.1	<b>Wheel</b>	Single flange taper thread
10.2	Wheel conform to (Std. / code)	IS: 3938
10.3	Wheel material	As per IS 3938
10.4	Bearing type	Antifriction Ball
11.0	<b>SHEAVE</b>	
11.1	Material	Cast / forged steel. IS: 2062 Gr. B / as per IS: 3938
11.2	Bearing type	Antifriction Ball
12.0	<b>BRAKE (Hoist)</b>	
12.1	Type	ACEM / DC EM brakes
12.2	Capacity	150 % of FLT
12.3	Number	One number for each motor
13.0	<b>BRAKE (Trolley)</b>	
13.1	Type	ACEM / DC EM brakes
13.2	Capacity	125 % of FLT or 100% of motor torque (Which ever is higher)



TITLE:  
**TECHNICAL SPECIFICATION FOR  
 OZONE GENERATION PLANT**  
**1X700 MW BELLARY THERMAL POWER  
 STATION UNIT NO. 3, STAGE-3**

BHEL DOCUMENTS NO.: PE-TS-367-174-14000A-A001

VOLUME **II-B**

SECTION -D1

REV. NO. 01

DATE: 24/02/2014

13.3	Number	One number for each motor
14.0	<b>ROPE DRUM</b>	
14.1	Material	As per IS 3938. Seamless steel pipe. ASTM A106 /A53 grade B
14.2	Type of groove	Right hand groove or Right hand and left hand groove
14.3	Spare groove on drum	One (1) spare groove when the hook is at its highest position
15.0	<b>TYPE OF DSL</b>	
15.1	Travel	PVC shrouded bus bar conductor type
16.0	<b>MOTORS</b> (for hoisting and trolley)	( As per IS: 325 & IS : 3938)
16.1	Type	Sq. Cage induction, TEFC, S4 duty, 40% CDF
16.2	Number of start	150 starts / hr
16.3	Voltage, Phase and Frequency	415V + 10%, 3 phase, 4 wire, 50 Hz, ± 5 %, combined variation of +-10%
16.4	Class of insulation	Class "F" and temperature rise limited to class "B".
16.5	Type of enclosure	TEFC
16.6	Degree of protection provided for enclosure	IP-55
16.7	Margin	Margin for motor rating shall be 15% over maximum power requirement at the rated speed.
16.8	RPM	Shall not exceed 1500RPM
16.9	Starting torque	The starting torque of the main motor shall be minimum 225% of FLT
16.10	Pull out torque	275% of FLT
17.0	<b>LIMIT SWITCHES</b>	Hoisting / lowering Trolley
17.1	Type	Snap action, self actuating type / two way lever
18.0	<b>Operation from</b>	Pendant push button for all motions of hoist
19.0	<b>Power cable</b>	FRLS / EPR flexible Cu cable / Aluminum cable
20.0	<b>Control cable</b>	FRLS / EPR flexible Cu cable / Aluminum cable
21.0	<b>Control Voltage</b>	110 V
22.0	<b>Buffer stop/wheel stop</b>	Buffer shall be provide at the end of monorail beam



TITLE:

**TECHNICAL SPECIFICATION FOR  
OZONE GENERATION PLANT**

**1X700 MW BELLARY THERMAL POWER  
STATION UNIT NO. 3, STAGE-3**

**BHEL DOCUMENTS NO.: PE-TS-367-174-14000A-A001**

**VOLUME II-B**

**SECTION -D2**

**REV. NO. 01**

**DATE: 24/02/2014**

**SECTION – D2**

**D2: GENERAL TECHNICAL REQUIREMENTS FOR ELECTRICAL**



TITLE:

**TECHNICAL SPECIFICATION FOR  
OZONE GENERATION PLANT**

**1X700 MW BELLARY THERMAL POWER  
STATION UNIT NO. 3, STAGE-3**

**BHEL DOCUMENTS NO.: PE-TS-367-174-14000A-A001**

**VOLUME II-B**

**SECTION -D2**

**REV. NO. 01**

**DATE: 24/02/2014**

**GENERAL TECHNICAL REQUIREMENTS FOR MOTORS**

KPCL/BTPS/03/EPC	KARNATAKA POWER CORPORATION LIMITED
	BELLARY TPS.UNIT-3 OF 700 MW TITLE MOTORS
1.0 1.1 1.2 1.3 1.4 1.5 1.6 1.7 1.8 1.9 1.10	<p><b>A.C. MOTORS</b></p> <p>All HT motors shall be suitable for 11kV / 3.3kV, 3 phase, 50 Hz and LV motors shall be suitable for 415V, 3 Phase, 50 Hz power supply.</p> <p>The motor rating shall be arrived at considering 15% margin over the duty point input or 10% over the maximum demand of the driven equipment, whichever is higher. Motors shall be capable of starting and accelerating the load with the applicable method of starting without exceeding acceptable winding temperatures when supply voltage is 80% of the rated voltage for HT motors and 85% for LV motors. HT motors shall also be capable of satisfactory operation at full load at a supply voltage of 80% of the rated voltage for 5 min. commencing from hot condition.</p> <p>Motors shall be capable of developing the rated full load torque even if the supply voltage drops to 70% of the rated voltage. If such operation is envisaged for a period of one second, the pull out torque of the motor shall be atleast 205% of full load torque.</p> <p>Motors shall withstand for 1 second the voltage and torque stresses developed due to the vector difference between the motor residual voltage and the incoming supply voltage equal to 150% of the rated voltage during fast change over of buses.</p> <p>Locked rotor current of the HT motors rated 1500 kW and below shall be limited to 600% inclusive of 20% tolerance of the full load current of the motors and motor rated above 1500 kW shall be limited to 450% (inclusive of 20% tolerance) of full load current of the motor. Locked rotor current of the LV motor shall not exceed 600% of full load current inclusive of 20% tolerance.</p> <p>The locked rotor withstand time under hot condition at 110% rated voltage shall be more than the starting time at minimum permissible voltage specified above by atleast three seconds or 15% of the accelerating time whichever is greater. Provision of speed switch shall be avoided to the extent possible.</p> <p>The degree of protection for the motor enclosure shall be IP-55 and IP-54 for outdoor &amp; indoor respectively and terminal boxes shall be provided with atleast IP-55. For single core cable termination, gland plates shall be of non-magnetic material. All motors located in hazardous area shall have flame proof design.</p> <p>All HT motors shall be provided with vibration pads for mounting vibration detectors.</p> <p>Motors rated 1000 kW and above shall be provided with differential protection. These motors shall be provided with star connected stator windings. The 3 nos. current transformers, one for each phase shall be mounted in a separate compartment in the neutral side terminal box. The three phases shall be connected to form the star point after they pass through the CTs. The CTs shall be of relay accuracy and the CT characteristics shall be compatible with the differential relay. The additional 3 nos. CTs of identical characteristics shall be provided in the 11kV / 3.3 kV switchgear panel. kWh meters shall be provided on all motor feeders.</p> <p>The ring oiling system shall be adequate for starting and continuous operation of the motor for atleast one half hour without pressure oiling system in operation.</p> <p style="text-align: center;"><del>224</del></p>

KPCL/BTPS/03/EPC	KARNATAKA POWER CORPORATION LIMITED BELLARY TPS, UNIT-3 OF 700 MW
	TITLE MOTORS
<p>1.11</p> <p>1.12</p> <p>1.13</p> <p>1.14</p> <p>1.15</p> <p>1.16</p> <p>2.0</p> <p>2.1</p> <p>3.0</p> <p>3.1</p> <p>3.2</p> <p>3.3</p> <p>3.4</p> <p>3.5</p>	<p>For 11kV &amp; 3.3kV motors, 6 nos. duplex/ 12 nos. simplex RTDs for winding shall be provided. Each bearing shall be provided with one no. PT-100 duplex type RTDs for temperature monitoring. These motors shall be designed to withstand atleast 5% harmonics in the supply voltage.</p> <p>The maximum double amplitude vibrations for motors upto 1500 rpm shall be 25 microns and 15 microns upto 3000 rpm. For 415V motors, maximum double amplitude vibrations upto 1500 rpm shall be 40 microns and 15 microns upto 3000 rpm.</p> <p>Maximum noise level measured at a distance of 1 metre from the outer surface of the motor shall not exceed 85 dB (A).</p> <p>Cable boxes of all 11kV &amp; 3.3kV motors shall be provided with quick disconnecting type terminal connectors to facilitate easy disconnection and removal of the motors without requiring unsealing or otherwise disturbing the external cable connections and leaving the phase segregated terminal box intact.</p> <p>The insulation system for 11000V &amp; 3300 V AC motors shall withstand the negative or positive 0.3 / 3.0 microsecond wave (2.7 pu rated peak line to earth operating voltage) switching surges originating from non-effectively earthed power system. All 11000V &amp; 3300 V AC motors shall have BIL and withstand frequency voltage as per relevant standards.</p> <p>If required by the system, variable frequency controller shall be provided for I.D. Fans.</p> <p><b>DC MOTORS</b></p> <p>DC motors shall be suitable for the DC system voltage available in the plant. Motor shall be capable of starting and accelerating the load with the applicable method of starting, without exceeding acceptable winding temperatures, when the supply voltage is in the range of 85% to 110% of rated motor voltage. The field windings for the motors shall be continuously rated without forced ventilation.</p> <p><b>ACTUATOR MOTORS</b></p> <p>The actuator motors shall be designed for short time duty (S2) in accordance with IEC 60034-1.</p> <p>Hand wheel operation shall be provided in addition to motor drive.</p> <p>The DC and AC actuator shall be provided with accessories viz., Torque limit switch, end of travel switch, adjustable limit switch, hand wheel motor, thermostat, integral starter, valve position indicator, Manual-Auto lever with suitable locking arrangement, etc.. Complete actuator shall be tested at factory as per IS 9334.</p> <p>Two normally open and two normally closed or two changeover potential free contacts corresponding to open and close positions of the valve shall be provided.</p> <p>Degree of protection for actuator motor enclosure shall be IP-55 and IP-67 for indoor and outdoor respectively.</p>

~~225~~

KPCL/BTPS/03/EPC 	<b>KARNATAKA POWER CORPORATION LIMITED</b> <b>BELLARY TPS, UNIT-3 OF 700 MW</b>			
	TITLE <b>MOTORS</b>			
<b>4.0 TESTS</b>				
<b>4.1</b> Tests on all types of motors shall be conducted as per relevant standard.				
<b>4.2</b> All type, routine & acceptance tests as per relevant IS shall be conducted on 11 kV & 3.3 kV motors. For LT motors, type test for each rating and frame size & make, and for all motors routine and acceptance tests shall be conducted as per relevant standards.				
<b>4.3</b> For 11000V and 3300V AC motors, in addition to all the tests specified above, polarisation index test shall be carried out as a routine test on each motor (the minimum value of polarisation index for all motors shall be 2 when determined according to IS : 7816).				
<b>4.4</b> Noise level measurement and vibration test as per standards shall be conducted on all motors.				
<b>4.5</b> Di-electric tests to establish the insulation withstand level of motors as indicated in Clause 1.15 shall be performed on a sample coil (identical to those to be used in the motor quoted for) for each type of motor. These tested sample coils shall not be used in the motors to be supplied.				
<b>4.6</b> All characteristic curves for the motors including hot and cold withstand characteristics, starting time vs current, current vs speed, speed vs torque at 110%, 100% and 90% of rated voltage, negative withstand characteristics, rotor voltage vs rotor current curves (for wound motors), Efficiency, power factor, slip, current Vs output curve etc., shall be furnished.				
<b>5.0 TECHNICAL REQUIREMENTS</b>				
The motors shall comply with the particulars indicated below and CONTRACTOR shall furnish the details in respective column given below (to be separately submitted for different type & rating of the motor).				
<b>SL. NO.</b>	<b>DESCRIPTION</b>	<b>UNIT</b>	<b>SPECIFICATION REQUIREMENT</b>	<b>CONTRACTOR</b>
1	AC Motors			
1.0	Application/Designation			
2.0	Manufacturer			
3.0	Type of motors/ frame size		Squirrel cage except for cranes	
4.0	Rated			
	(a) Output	kW	*	
	(b) Speed	rpm	*	
	(c) Voltage	V	*	

KPCL/BTPS/03/EPC 	<b>KARNATAKA POWER CORPORATION LIMITED</b> <b>BELLARY TPS, UNIT-3 OF 700 MW</b>
	TITLE <b>MOTORS</b>

	(d) No. of Phases / Frequency		*	
	(e) System neutral		*	
5.0				
5.1	Type of Duty (IS-325 or equivalent)		*	
5.2	Duty designation (IS-325 or equivalent)		*	
6.0	Supply Conditions			
	(a) Allowable variations in			
	(i) Voltage	%	± 10	
	(ii) Frequency	%	± 5	
	(iii) Combined	%	± 10	
	(b) Permissible unbalance in supply voltage	%	2	
7.0	Current		*	
	(a) Full load	Amps,	*	
	(b) Starting	% FL	*	
8.0	Method of starting			DOL
8.1	Starting time	Sec		
	With rated Voltage			
	With min. Voltage			
	With Max. Voltage			
8.2	Safe stall time under hot/cold condition	Sec		
	With rated Voltage			
	With min. Voltage			
	With Max. Voltage			
9.0	Insulation			
9.1	Class of insulation			Class F with temperature rise limited to Class B

~~227~~

KARNATAKA POWER CORPORATION LIMITED		BELLARY TPS.UNIT-3 OF 700 MW	
KPC/ BTSPS/03/EPC		TITLE	
		MOTORS	
9.2	Temperature rise by winding resistance method	Deg. C	For LV motors (Temp. limited to 65°C), For HT motors (temp. rise limited to Class B)
10.0	Type of cooling (IS : 6362)	Deg. C	TEFC for LV, TEFC / TETV/CACA for 11/3.3 KV motors.
11.0	Degree of protection (IS:4691 or equivalent)		Refer Clause 1.7
12.0	Suitable for outdoor operation	Yes / No	*
13.0	Normal winding connection	Star / Delta	*
14.0	Permissible No. of equally spread starts per hour under normal service conditions		*
15.0	Efficiency (%)	%	
	Full load		
	75 % Load		
	50 % Load		
	25 % Load		
16.0	Power Factor		
	Full Load		
	75 % Load		
	50 % Load		
	25 % Load		
17.0	Torque		
	Starting		
	Maximum (Pullout)		
	Pull up		
18.0	Motor reactance (pu)		
	Subtransient		
	Transient		
	Steady state		
15.0	Fault level	kA/se c	*

KPCL/BTPS/03/EPC  	<b>KARNATAKA POWER CORPORATION LIMITED</b> <b>BELLARY TPS UNIT-3 OF 700 MW</b>
	TITLE <b>MOTORS</b>

II	<b>DC MOTORS</b>		
16.0	Rated Voltage	V	220 V DC
17.0	Class of Insulation	:	Class F with temperature rise limited to class B
18.0	Temperature rise	:	--- do -----
19.0	Method of starting	:	*
Items under AC motors which are applicable for DC motors shall also be listed			

NOTE :

1.0 Information shall be filled furnished by CONTRACTOR along with offer.

~~229~~



TITLE:

TECHNICAL SPECIFICATION FOR  
OZONE GENERATION PLANT

1X700 MW BELLARY THERMAL POWER  
STATION UNIT NO. 3, STAGE-3

BHEL DOCUMENTS NO.: PE-TS-367-174-14000A-A001

VOLUME II-B

SECTION -D2

REV. NO. 01

DATE: 24/02/2014

**DATA SHEET – C OF MOTORS**

S. No.	Description	Data to be filled by successful bidder
<b>A.</b>	<b>vi) General</b>	
1	Manufacturer & country of origin	
2	Motor type	
3	Type of starting	
4	Name of the equipment driven by motor & Quantity	
5	Maximum Power requirement of driven equipment	
6	Rated speed of Driven Equipment	
7	Design ambient temperature	
<b>B.</b>	<b>vii) Design and Performance Data</b>	
1	Frame size & type designation	
2	Type of duty	
3	Rated Voltage	
4	Permissible variation for	
5	a) Voltage	
6	b) Frequency	
7	c) Combined voltage & frequency	
8	Rated output at design ambient temp (by resistance method)	
9	Synchronous speed & Rated slip	
10	Minimum permissible starting voltage	
11	Starting time in sec with mechanism coupled	
12	a) At rated voltage	
13	b) At min starting voltage	
14	Locked rotor current as percentage of FLC (including IS tolerance)	
15	Torque	
	a) Starting	
	b) Maximum	
16	Permissible temp rise at rated output over ambient temp & method	
17	Noise level at 1.0 m (dB)	
18	Amplitude of vibration	



TITLE:

**TECHNICAL SPECIFICATION FOR  
OZONE GENERATION PLANT**

**1X700 MW BELLARY THERMAL POWER  
STATION UNIT NO. 3, STAGE-3**

BHEL DOCUMENTS NO.: PE-TS-367-174-14000A-A001

**VOLUME II-B**

**SECTION -D2**

REV. NO. 01

DATE: 24/02/2014

S. No.	Description	Data to be filled by successful bidder
19	Efficiency & P.F. at rated voltage & frequency	
	a) At 100% load	
	c) At 75% load	
	c) At starting	
<b>C.</b>	<b>viii) Constructional Features</b>	
1	Method of connection of motor driven equipment	
2	Applicable Standard	
3	DOP of Enclosure	
4	Method of cooling	
5	Class of insulation	
6	Main terminal box	
	a) Type	
	b) Power Cable details (Conductor, size, armour/unarmour)	
	c) Cable Gland & lugs details (Size, type & material)	
	d) Permissible Fault level ( kArms & duration in sec)	
7	Space heater details (Voltage & watts)	
8	Flame proof motor details (if applicable)	
	a) Enclosure	
	b) suitability for hazardous area	
	i Zone	O / I / II
	ii Group	IIA / IIB / IIC
9	No. of Stator winding	
10	Winding connection	
11	Kind of rotor winding	
12	Kind of bearings	
13	Direction of rotation when viewed from NDE	
14	Paint Shade & type	
15	Net weight of motor	
16	Outline mounting drawing No (To be enclosed as annexure)	
<b>D.</b>	<b>ix) Characteristic curves/ drawings</b> (To be enclosed for motors of rating $\geq 55KW$ )	
	a) Torque speed characteristic	



TITLE:

**TECHNICAL SPECIFICATION FOR  
OZONE GENERATION PLANT**

**1X700 MW BELLARY THERMAL POWER  
STATION UNIT NO. 3, STAGE-3**

**BHEL DOCUMENTS NO.: PE-TS-367-174-14000A-A001**

**VOLUME II-B**

**SECTION -D2**

**REV. NO. 01**

**DATE: 24/02/2014**

<b>S. No.</b>	<b>Description</b>	<b>Data to be filled by successful bidder</b>
	b) Thermal withstand characteristic	
	c) Current vs time	
	d) Speed vs time	



TITLE:

**TECHNICAL SPECIFICATION FOR  
OZONE GENERATION PLANT**

**1X700 MW BELLARY THERMAL POWER  
STATION UNIT NO. 3, STAGE-3**

**BHEL DOCUMENTS NO.: PE-TS-367-174-14000A-A001**

**VOLUME II-B**

**SECTION -D2**

**REV. NO. 01**

**DATE: 24/02/2014**

**GENERAL TECHNICAL REQUIREMENTS FOR CABLES**

 <p>KPCL/BTPS/03/EPC</p>	<p><b>KARNATAKA POWER CORPORATION LIMITED</b> <b>BELLARY TPS, UNIT-3 OF 700 MW</b></p> <p>TITLE <b>CABLING SYSTEM</b></p>
<p>1.0 1.1 1.2 1.3 1.4 1.5</p>	<p><b>CABLES</b></p> <p><b>H T Cables</b></p> <p>MV system (11kV &amp; 3.3kV system) cables shall be unearthed grade suitable for use in medium resistance earthed system, with stranded &amp; compacted aluminium conductors, extruded semi-conducting compound screen, extruded XLPE insulated, Dry cured extruded semi-conducting compound with a layer of non-magnetic metallic tape for insulation screen, extruded PVC (Type ST - 2) FRLS inner sheath, Aluminium / galvanised steel round wire armoured, extruded PVC (Type ST - 2) FRLS outer sheathed, single / multicore conforming to IS 7098 (Part II) for constructional details and tests.</p> <p><b>L T Power Cables</b></p> <p>LV Power Cable shall be 1100 V grade, single / multicore, stranded aluminium conductor, XLPE insulated, <del>with</del> with PVC inner sheath, Type ST - 2 and outer sheath made of FRLS PVC, Type ST-2 compound. The armoring shall be of Aluminium / galvanised steel round wire. The cable used for DC system shall be of single core type. All other details shall be as applicable. Minimum conductor cross section of power cables shall be 4 sq.mm. <i>steam/singles/gas cured</i></p> <p><b>Control Cables</b></p> <p>Control cables shall be 1100V grade, multicore, minimum 2.5 sq.mm cross section, stranded copper conductor having 7 strands, PVC insulated, inner PVC sheathed, galvanised steel wire armoured and outer sheath made of FRLS PVC compound. In situations where accuracy of measurement or voltage drop in control circuit, warrant, higher cross sections as required shall be used. 4 sq.mm copper conductor cables shall be used for CT circuits all other specifications remaining same.</p> <p><b>Instrumentation Cables</b> <i>Page 38, Mem part 2 of 3, 1.1kV</i></p> <p>Instrumentation cables shall be with stranded high conductivity annealed, tinned copper, twisted pair (with min. 20 twists per meter) extruded PVC insulated with overall and / or individual screening, extruded PVC inner sheathed, extruded outer sheathed with FRLS PVC compound and aluminium/galvanised steel wire armoured complying to IEC60189 - Part I &amp; II</p> <p>The conductor size shall be minimum 0.5 sq.mm. Triplex cables similar to instrumentation cables can be used for RTDs.</p> <p><b>Lighting Wires</b></p> <p>1100V grade, single core, stranded, copper conductor, PVC insulated wires conforming to IS-694-1990 / IEC-60227 Part 1 to 5 (1979) / IEEE-719 (1981). Minimum cross section of copper wires shall be 2.5 sq.mm for lighting circuits and 4 sq. mm for receptacle circuits.</p>

<p>KPCL/BT/PS/03/EPC</p> 	<p><b>KARNATAKA POWER CORPORATION LIMITED</b></p>
	<p><b>BELLARY TPS, UNIT-3 OF 700 MW</b></p>
	<p>TITLE <b>CABLING SYSTEM</b></p>
<p>1.6</p> <p>2.0</p> <p>2.1</p> <p>2.2</p> <p>2.3</p> <p>2.4</p> <p>3.0</p> <p>3.1</p> <p>3.1.1</p>	<p><b>Trailing Power and Control cables for Mobile Equipment.</b></p> <p>11kV / 3.3 kV (UE) and 1100V (E) grade power &amp; control flexible trailing, annealed tinned copper conductor, EPR insulated, EPR inner sheathed, CSP outer sheathed and shall have conductor screen of rubber. Cables shall conform to IS requirements and any other applicable standards.</p> <p><b>CABLE PROPERTIES</b></p> <p>All power, control and instrumentation cable will be with armour. MV cables will be with FRLS PVC inner and outer sheath and other type of cables are with FRLS PVC, Outer sheath.</p> <p>All single core power cables will have wire armouring of aluminium, whereas multicore cables will have galvanised steel wire armouring.</p> <p>The outer sheath of all cables shall be of extruded layer of suitable synthetic material compatible with specified ambient and operating temperature of the cables. The sheath shall be resistant to water, UV radiation, fungus, termite and rodent attack.</p> <p>The inner and outer sheath of FRLS PVC compound shall meet the following performance requirements :</p> <p>(a) The critical oxygen index value shall be minimum 29 when tested at <math>27 \pm 2^\circ\text{C}</math> as per ASTM-D-2863-77 and the temperature index will be minimum <math>250^\circ\text{C}</math> at oxygen index value of 21 when tested as per <del>NES 715</del>. <del>ASTM-D-2863</del></p> <p>(b) The maximum acid gas generation as determined by titration shall be less than 20% by weight when tested as per IEC-60754-1 (1994).</p> <p>(c) The smoke generation under fire shall have maximum smoke density rating of 60% when tested as per ASTM-D-2843-7 (1988).</p> <p>(d) The cables will pass the hydraulic stability and ultraviolet tests as per DIN 53387.</p> <p>The finished cable shall pass the flammability test as per IEC-60322-1 (1993) and IEEE-60383. In addition, it shall also pass flammability test as per Class F3 of Swedish Standard SS-424-1475 (1978).</p> <p><b>DESIGN CRITERIA FOR CABLE SIZING</b></p> <p><b>Power cables</b></p> <p>Power cable sizes shall be selected on the basis of current carrying capacity, short circuit rating, permissible voltage drop and standardization of cable sizes.</p> <p>Power cables shall carry the full load current of the circuit continuously under site conditions considering the various derating factors like Thermal resistivity of soil, ambient air/ground temperature, grouping, method of laying, etc. The</p>

<p>KPCL/BTPS/03/EPC</p> 	<p><b>KARNATAKA POWER CORPORATION LIMITED</b></p> <p><b>BELLARY TPS UNIT-3 OF 700 MW</b></p>	
	<p>TITLE</p> <p><b>CABLING SYSTEM</b></p>	
<p>design ambient air and ground temperatures shall be considered at 50° C &amp; 30° C respectively.</p>		
<p>3.1.2</p>	<p>Power cables shall withstand the fault current of the circuit for the duration not less than the maximum time taken by the primary protective system to isolate the fault. Fault clearing times for 11000V / 3300V motor feeders and transformer feeders having high-set instantaneous protection shall be 0.16 secs., whereas tie between two 415V switchgear and any two 11000V / 3300V switchgear shall be 0.5 secs., and for incomers and tie feeders 1.0 sec.</p> <p>The short circuit withstand capacity of screen in case of HT cables shall be 300 amps for 2(two) seconds per core.</p>	
<p>3.1.3</p>	<p>For 11000V / 3300V motors controlled by vacuum contactors with back-up HRC fuses, the minimum cross-section of cables shall be based on the cut-off current of the fuses and their fusing time.</p>	
<p>3.1.4</p>	<p>For the cables to 415V motors and feeders protected by fuses, the cross section shall be chosen according to the cut-off current of the fuse and its fusing time.</p>	
<p>3.1.5</p>	<p>Voltage dip at motor terminals during starting of motors will be limited to the following values :</p> <p>(i) For coal mill motors – 10% of the rated voltage. (ii) For all motors except BFP – 15% of the rated voltage. (iii) For BFP motors – 20% of the rated voltage. (iv) For LV motors – 15% of the rated voltage.</p>	
<p>3.1.6</p>	<p>Voltage drop in feeder cables between the transformer &amp; PCC and between PCC &amp; MCC, for full load current, shall be limited to 2 %. Further, the Voltage drop in feeder cables between PCC/MCC to Motor terminals shall be limited to 3% during full load running condition.</p>	
<p>3.1.7</p>	<p>For power supply to valve actuator motors, actuators of various isolating and regulating dampers and exhaust fans, 3 core 2.5 sq. mm stranded copper conductor cable may be used in view of ease of termination. These cables shall be in other respects similar to cables described in Clause 1.2 above.</p>	
<p>3.2</p>	<p><b>Control Cables</b></p>	
<p>3.2.1</p>	<p>Current transformers leads shall be checked for the load burden vis-a-vis the current transformer VA capacity and 4 sq.mm cables shall be used for connection of CT to loads. In case 4 sq.mm conductor imposes unacceptable high burden on CTs, higher cross section of conductor shall be used.</p>	
<p>3.2.2</p>	<p>Voltage transformer leads shall be checked for voltage drop, which shall be limited to within 1% for all cases other than tariff metering. For tariff metering the voltage drop shall be limited to 0.2%. In case the voltage drop with 4 sq. mm Cu conductors exceed this value, higher conductor sizes shall be used.</p>	

KPCL/BTPS/03/EPC	<b>KARNATAKA POWER CORPORATION LIMITED</b>
	<b>BELLARY TPS, UNIT-3 OF 700 MW</b> TITLE <b>CABLING SYSTEM</b>
<b>3.3</b>	<b>Instrumentation Cables</b>
	Instrumentation cables shall comply with the Electrical Properties suitable for the Digital and Analogue signals.
<b>4.0</b>	<b>CABLE TERMINATIONS</b>
<b>4.1</b>	All 11000V / 3300V termination kits shall be of heat shrinkable type and suitable for XLPE insulation and the same shall have been tested for a short circuit current as per relevant Standards
<b>4.2</b>	All 1100V termination for XLPE/PVC power cables and control cables shall be by crimping type tinned copper / aluminum lugs.
<b>5.0</b>	<b>CABLE JOINTS</b>
	Cable joints shall be avoided to the extent possible. If joints are unavoidable due to circuit length, in excess of permissible maximum drum length, they shall be heat shrinkable type having a short circuit with stand capacity of 40kA for 0.5 sec. for 11kV / 3.3kV cables and 50kA for 0.5 sec. for 1100V grade cables.
<b>6.0</b>	<b>POWER RECEPTACLES</b>
	3 phase, 4 pin, 63A power receptacles with switch shall be provided two in each floor of TG building, boiler platforms and one in each pump house. The receptacle shall be industrial heavy duty type and shall have suitable interlock facility for safety. The receptacle shall conform to IS 1293 and the switch to IS 4064.
<b>7.0</b>	<b>CABLE CARRIER SYSTEM</b>
<b>7.1</b>	The cable carrier system shall be designed considering the following :
	<ul style="list-style-type: none"> <li>(a) Facility for easy laying of cables.</li> <li>(b) Access to maintenance.</li> <li>(c) Neat and aesthetic appearance.</li> <li>(d) Safety of equipment &amp; personnel.</li> <li>(e) Ground water seepage.</li> </ul>
<b>7.2</b>	Cables shall be laid in prefabricated ladder/ Perforated type trays and in conduits. Direct burial of cable shall be avoided as far as possible. In case cables are buried, length of burial shall be limited to about 10 M and depth of burial shall be about 750 mm. Cable route markers shall be provided at every 15 m intervals and at bends. Also joint markers shall be provided at each joint.
<b>7.3</b>	Cable tunnels are not acceptable. Cables shall necessarily be run in overhead racks.

	<b>KARNATAKA POWER CORPORATION LIMITED</b>
	<b>BELLARY TPS, UNIT-3 OF 700 MW</b>
<b>TITLE</b> <b>CABLING SYSTEM</b>	

**8.0 CABLE INSTALLATION AND ACCESSORIES**

8.1 All material and accessories required for cable installation like cable trays, tray covers, support steel, etc., shall be hot dip galvanised and conduits/pipes shall also be hot dip galvanised.

The racks/trays, conduits/pipes, trenches required to route the cables to individual equipments shall be supplied and installed by the CONTRACTOR.

8.2 Separate trays shall be provided for HV Power/LV Power (AC&DC)/Control & Instrumentation cables.

**9.0 CABLE TRAYS AND COVERS**

9.1 Cable trays shall be of ladder / perforated type complete with all necessary coupler plates, elbows, tees, bends, reducers, stiffeners and other accessories. Cable trays of ladder and perforated types and the associated accessories such as coupler plates, tees, elbows, etc. shall be fabricated from 12 gauge (2.5 mm thick) mild steel sheets. cable tray covers shall be fabricated from 16 gauge (1.7 mm thick) MS sheets. All the sheet steel shall be hot dip galvanised as per relevant standards.

Cable trays shall be ladder type for power & control cables and perforated type for Instrumentation cables.

9.2 Cables of sizes 120 sq.mm and above shall be laid in single layer. Single core cables used for 3 phase AC power circuits shall be laid in Trefoil form.

**10.0 FIRE-PROOF SEALING OF CABLE PENETRATION**

Cables / cable tray openings in walls and floors or through pipe sleeves from one area to another or one elevation to another, between the units and within the same unit, shall be sealed by a fire-proof sealing system. The fireproof sealing system (FPSS) shall effectively prevent the spread of fire from the flaming to the non-flaming side, in the event of a fire. The FPSS shall conform to relevant standard in addition to the following requirements :

- (a) FPSS shall have a fire rating of two hours. ✓
- (b) The FPSS shall be subjected to fire endurance test, hose stream test, temperature measurement of non-flaming side as per ASTM-E119. 'Standard method of fire tests of building construction and materials'.
- (c) The FPSS will also conform to the incombustibility test carried out in accordance with IS:3144-1992.
- (d) Under fire condition, the FPSS material shall not emit excessive smoke or any corrosive or toxic fumes.

KPCU/BTPS/03/EPC	<b>KARNATAKA POWER CORPORATION LIMITED</b>
	<b>BELLARY TPS UNIT-3 OF 700 MW</b>
	TITLE
	<b>CABLING SYSTEM</b>
11.0	<b>FIRE BREAK</b>
11.1	Firebreak shall be provided by applying a suitable fire-resistant coating on cables for the required length to meet the fire rating of thirty minutes.
11.2	Firebreak shall be provided at an interval of 15 metres in the straight portion of each of the cable tray above ground, at intervals of 30 metres in cable trenches and at 5M for all vertical trays. All cable inter section and tee offs shall be provided with firebreaks.
12.0	<b>TESTS</b>
	All tests shall be carried out as per relevant standards and approved GTP/QAP.

~~196~~



TITLE:

**TECHNICAL SPECIFICATION FOR  
OZONE GENERATION PLANT**

**1X700 MW BELLARY THERMAL POWER  
STATION UNIT NO. 3, STAGE-3**

**BHEL DOCUMENTS NO.: PE-TS-367-174-14000A-A001**

**VOLUME II-B**

**SECTION -D2**

**REV. NO. 01**

**DATE: 24/02/2014**

**GENERAL TECHNICAL REQUIREMENTS FOR PANELS, CABINETS  
& MISCELLANEOUS ELECTRICAL EQUIPMENTS**

KPCL/BTPS/03/EPC



KARNATAKA POWER CORPORATION LIMITED

BELLARY TPS, UNIT-3 OF 700 MW

TITLE

CONTROL PANELS & CABINETS AND MISCELLANEOUS ELECTRICAL EQUIPMENT

**1.0 CONTROL PANELS & CABINETS AND MISCELLANEOUS ELECTRICAL EQUIPMENT**

1.1 Indoor control panels provided for control of miscellaneous systems in the plant viz., air conditioning, evaporative air cooling, fire protection system and outdoor control cabinets shall comply with the requirements outlined under clause 1.5 below.

1.2 All the meters provided on the panel shall be min. 96 sq.mm with an accuracy class of 0.5 unless otherwise specified. Tariff meters shall have an accuracy of 0.2. All meters shall be of digital type.

1.3 The facia annunciation windows if provided on the panel, shall conform to requirements outlined under instrumentation and control section.

1.4 The required 240V, 1 phase AC supply required for panel illumination, receptacle and for space heating of panel shall be derived in the control panel itself.

**1.5 Technical Requirements**

SL. NO.	DESCRIPTION	REQUIREMENTS
1	Location	Indoor/Outdoor depending location
2	Type of mounting	Wall/Floor
3	Cable entry	Top/bottom depending on layout
4	Paint Finish: Outside/Inside	To be decided later/ glossy white.
5	Supply voltage	415V 3 phase 3 wire
6	Control transformer	Required to derive 110V control supply
7	Space heater, lighting supply voltage	240V, 1 phase AC
8	Applicable standards	
9	Switchgear general requirements	IS 4237
10	Factory built assemblies of switchgear and control gear for voltages upto and including 1000V AC & 1200V DC	IS 8623

~~230~~

KPCL/BTPS/03/EPC



**KARNATAKA POWER CORPORATION LIMITED**

**BELLARY TPS, UNIT-3 OF 700 MW**

TITLE

**CONTROL PANELS & CABINETS AND MISCELLANEOUS  
ELECTRICAL EQUIPMENT**

11	Air break switches	IS 13947 pt 1 & 2
12	Miniature circuit breakers	IS 8828
11.5	HRC cartridge fuses	IS 9224
11.6	Contactors	IS 2959
11.7	Control switches/push buttons	IS 6875
11.8	Current transformers	IS 2705
11.9	Voltage transformers	IS 3156
11.10	Relays	IS 3231
11.11	Indicating instruments	IS 1248
11.12	Arrangement for bus bars, main connections and accessories	IS 375
11.13	Degree of Protection	IS 2127 / 3427
11.14	Climate proofing of electrical equipment	IS 3202
11.15	Code of practice for phosphating iron & steel	IS 6005
11.16	Wrought aluminium and aluminium alloys for electrical purposes	IS 5082

2.0 Following miscellaneous equipment shall be included in CONTRACTOR'S scope.

2.1 Local push button stations.

2.2 Junction boxes (JBs)

2.3 Danger boards

2.4 Rubber mats

3.0 **LOCAL PUSH BUTTON STATIONS (LPB)**

3.1 Local push button station shall be provided for all the drive motors of the plant (415V motors and 11kV & 3.3kV motors) (start stop push buttons for all motors; only stop push button for emergency motors).

3.2 The degree of protection of LPBs shall be IP55 with canopy for outdoor and IP54 for indoor applications.

3.3 All PBs shall be push to actuate type and the stop PB shall be lockable in off position.

~~281~~

KPCL/BTPS/03/EPC



**KARNATAKA POWER CORPORATION LIMITED**

**BELLARY TPS, UNIT-3 OF 700 MW**

TITLE

**CONTROL PANELS & CABINETS AND MISCELLANEOUS  
ELECTRICAL EQUIPMENT**

- 3.4 All push buttons shall be provided with 2 nos. NO and 2 nos. NC contacts for various interlocking purposes. One contact of stop PB shall be directly wired to the switchgear module for direct tripping and another contact to control system.
- 4.0 **JUNCTION BOXES (JBs)**
- 4.1 Junction boxes as required for the power plant shall be supplied :
- 4.2 The JB's used in outdoor areas shall be weatherproof type. Sheet steel thickness of the JB's shall be minimum 2 mm. The sheet steel shall be hot dip galvanised.
- 4.3 Junction boxes/marshalling boxes (JBs/MBs) shall be provided to enable running large core cables from (JB/MB) to control panels, terminal cabinets, etc.
- 4.4 Clause deleted.
- 5.0 Danger boards shall be provided in line with the statutory requirements.
- 6.0 Rubber mats shall be provided to meet the safety and other statutory requirements.

~~232~~