

GENERAL TERMS AND CONDITIONS OF TENDER ENQUIRY  
ANNEXURE-B

- 01 Submit the tender in two parts i.e.
  - Part-I Techno-Commercial Bid**
  - Part-II Price Bid**

Techo - Commercial (part one) Price Bid (part two) should be put in separate sealed envelopes. Both envelopes should be super scribed with **Tender Number, Date of opening & Technical / Commercial Bid and Price Bid** respectively along with name of firm. Both the envelopes i.e. containing Techno-Commercial Bid and Price Bid should again be kept in one envelope super scribed again with Tender No. and Date of opening and the name of firm submitting the tender and send it to **AGM (MM), Purchase Department, CFFP/BHEL, Hardwar, Ranipur, Hardwar 249403, Uttarakhand, India before due date / tender opening date & time.** Normally tender opening time is 2.00 PM on due date or as mentioned in enquiry.

**Responsibility for submission of tender in time solely lies with vendor. Late offers received after specified time / Date shall not be considered.**

- 1. Part-I Envelopes super scribed with **Techno-Commercial Bid** must contain all information especially-
  - (a) Specification of the material offered should be strictly as per CFFP/BHEL specifications of enquired material in tender documents **Deviations if any must be indicated clearly in the offer. Rates to be quoted on For Destination Basis.**
  - (b) All commercial terms i.e. packing, forwarding Custom duty, Additional Duty, ST/STT/VAT/CST, Excise Duty/CVD, Bank charges, payment terms & insurance etc as applicable **(except price)** should be clearly mentioned in Techno-Commercial bid. Also mention present rate of applicable taxes & duties even if inclusive in rates along with the concessional forms required if any.
  - (c) Confirm to submit all required commercial documents (tax invoice centvatable duplicate copy of invoice, packing list, transit sale agreement etc.) & technical documents (TC/GC/QP etc).
  - (d) Registration Numbers of SSI, Central Excise, Sales tax, Income Tax, DGS & D.ECC etc.
  - (e) **Un-priced copy of Price Bid.**

Part-II Envelopes super scribed with Price Bid should contain priced copy of Price Bid. The price should be mentioned both in figures and words.

- 2. Authorized Signatory should authenticate all tender documents.
- 3. **Techno-commercial bid (Part-I)** will be opened on the due date at 2.00 PM in the presence of participating vendors or authorized representatives, who may wish to be present. Representative deputed to witness tender opening must produce an authority letter from the signatory of offer. After evaluation of technical bids & finalization of technical, commercial terms & conditions, price bid of only successful vendors will be opened. Priced bid opening date shall be intimated separately.
- 4. The material offered must conform to the required BHEL specifications and drawings as well as instructions and details made available.
- 5. For new vendors, Vendor Registration form duly filled must be submitted along with the offer which can be downloaded from our web site [www.bhel.com](http://www.bhel.com) or [www.bhelhwr.co.in](http://www.bhelhwr.co.in).
- 6. Original manufacturer's Test Certificate is required along with dispatch documents. In case supplies are from traders, it shall be the responsibility of the trader to provide original manufacturer's test certificate with linkage to traders invoice stating batch no.
- 7. **Validity** of offers should be minimum 90 working days from the date of tender (Techno-Commercial Bid) opening.

- 8. **Delivery** in the promised period is the essence of contract. Confirm to supply according to delivery schedule mentioned.
- 9. **Payment terms:**  
 For indigenous suppliers: 100% within 30 days after receipt & acceptance of material at CFFP / BHEL, Haridwar through e-payment.  
 For foreign suppliers: Payment through USANCE LC on 70<sup>th</sup> day of bill of lading date. All bank charges shall be to vendor's account.  
  
 \* In case vendor does not agree, proper loading shall be done. Also in that case, third party inspection shall have to be arranged by supplier from any of the five inspection agencies namely: LRS/ BVQI/ DNV/ TUV/ Alfred H Knight at their cost.
- 10. CFFP/BHEL, Haridwar reserves the right to accept or reject any or all tenders without assigning any reason thereof.
- 11. Tenders not submitted in the prescribed manner are likely to be ignored / rejected.
- 12. Agent/Agency Commissioning: Payment of any kind at any stage will not be made to agent on account of agent commission or otherwise by CFFP/BHEL, Haridwar.
- 13. CFFP/BHEL, Haridwar may opt for E-auction/Reverse auction for obtaining best prices for part or full tendered quantity. BHEL also reserve the right to negotiate price with L1 vendor after reverse auction.
- 14. Please do intimate the personal contact details like Name, Mobile Number, Email-id etc of authorized executive for correspondence.
- 15. **Penalty:** Orders placed against this enquiry will be subject to normal clauses for imposing penalty. Liquidated Damages, Risk purchases, cancellation, arbitration as per terms and conditions of Tender Enquiry and Purchase orders in case of delay in effecting supply and/ or other defaults.  
**Liquidated damage:** The delivery of the goods shall be made strictly as per time limit specified in delivery schedule, failure to supply within this period will make the supplier liable to an conditional penalty of 1/2 (half) percent of the price of the goods in arrears per week subject to a maximum of 10%.
- 16. **Inspection:** Final inspection of material shall be done after receipt of material at CFFP/BHEL, Haridwar. Acceptance of material shall be after final inspection and shall be binding. However, CFFP reserves the right to pre Inspect the material at supplier works. In case material is found defective during warranty period, the same will be returned for repair and/ or replacement. For this vendor has to bear all the charges such as Freight, to and fro insurance etc. Bank Guarantee for the equal amount to the cost of the item is to be furnished by vendor. In case the repair is done at CFFP/BHEL the amount on actual shall have to be reimbursed by the Vendor and or adjusted on actual from their bill.
- 17. **Currency of Payment:** Mention the currency in which payment has to be made. For evaluation of price bids, exchange rate (TT selling rate of SBI) as on scheduled date of tender opening (Part-1 bid in case of two part bid) shall be considered.
- 18. Traders should submit authorization letter from their principal alongwith offer.
- 19. Disputes: In event of any dispute arising out of contractual obligation, the order being finalized at Haridwar, India will be subject to Indian Laws and falls under jurisdiction of the court of Law at Haridwar, India. The overseas supplier hereafter referred to as "Vendor" shall therefore abide by the verdict of Court of Law at Haridwar, India.  
 OR  
 All disputes arising out of or in connection with the present contract, if any shall be finally settled under the rules of arbitration of International chamber of commerce by one or more arbitrator appointed in accordance with the said Rules in India.
- 20. BHEL reserves the right to place P.O. for part / full qty and on one or more than one sources.
- 21. Any Term & condition of the specific tender (if specified in tender & contradicts with above term) will supersede the above general terms & conditions.

**Terms and conditions regarding Indian agent of foreign suppliers:**

01. BHEL shall deal directly with foreign vendors, wherever required, for procurement of goods. However, if the foreign principal desires to avail of the services of an Indian agent, then the foreign principal should ensure compliance to regulatory guidelines- which require mandatory submission of an Agency agreement.
02. It shall be incumbent on the Indian agent and the foreign principal to adhere to the relevant guidelines of Government of India, issued from time to time.
03. The agency agreement should specify the precise relationship between the foreign OEM/Foreign principal and their Indian agent and their mutual interest in the business. All services to be rendered by agent/associate, whether of general nature or in relation to the particular contract, must be clearly stated by the foreign supplier / Indian agent. Any payment, which the agent or associate receives in India or aboard from the OEM, whether as commission or as a general retainer fee should be brought on record in the agreement and be made explicit in order to ensure compliance to laws of the country.
04. Any agency commission to be paid by BHEL to the Indian agent shall be in Indian currency only.
05. Tax deduction at source is applicable to the agency commission paid to the Indian agent as per the prevailing rules.
06. In the absence of any agency agreement, BHEL shall not deal with any Indian agent (authorized representatives/ associate/consultant, or by whatever name called) and shall deal directly with the foreign principal only for all correspondence and business purposes.
07. The "Guidelines for Indian Agents of Foreign Suppliers" enclosed at annexure- 'A' shall apply in all such cases.
08. The supply and execution of the Purchase Order (including indigenous suppliers/service) shall be in the scope of the OEM/ Foreign principal. The OEM/ Foreign principal should submit their offer inclusive of all indigenous suppliers/services and evaluation will be based on 'total cost to BHEL'. Incase OEM/ foreign principal recommends placement of order(s) towards indigenous portion of supplies/services on Indian Supplier (s)/ agent on their behalf, the credentials/capacity/capability of the Indian Supplier (s)/ agent to make the supplies/Services shall be checked by BHEL as per the extant guidelines of Supplier Evaluation, Approval and Review Procedure (SEARP), before opening of price bids. In this regards, details may be checked as per Annexure- 'B' (copy enclosed). It will be the responsibility of the OEM/ Foreign Principal to get acquainted with the evaluation requirements of Indian supplier/agent as per SEARP available on [www.bhel.com](http://www.bhel.com).

The responsibility for successful execution of the contract (including indigenous supplies/services) lies with the OEM/ foreign principal. All bank guarantees to this effect shall be in the scope of the OEM/Foreign principal.

25

**Guidelines for Indian Agents of Foreign Suppliers**

- 1.0 There shall be compulsory registration of agents for all Global (Open) Tender and Limited Tender. An agent who is not registered with BHEL shall apply for registration in the registration form in line with SEARP.
- 1.1 Registered agents will file an authenticated Photostat copy duly attested by a Notary Public/Original certificate of the Principal confirming the agency agreement and giving the status being enjoyed by the agent and the commission/ remuneration/ salary/ retainership being paid by the principal to the agent before the placement of order by BHEL.
- 1.2 Wherever the Indian representatives have communicated on behalf of their principals and the foreign parties have stated that they are not paying any commission to the Indian agents, and the Indian representative is working on the basis of salary or as retainer, a written declaration to this effect should be submitted by the party (i.e. Principal) before finalizing the order.
- 2.0 **Disclosure of particulars of agents/ representatives in India, if any.**
- 2.1 Tenderers of Foreign nationality shall furnish the following details in their offers:
  - 2.1.1 The Bidder(s)/ Contractor(s) of foreign origin shall disclose the name and address of the agents/ representatives in India if any and the extent of authorization and authority given to commit the Principals. In case the agent/ representative be a foreign Company, it shall be confirmed whether it is existing Company and details of the same shall be furnished.
  - 2.1.2 The amount of commission/ remuneration included in the quoted price(s) for such agents/ representatives in India.
  - 2.1.3 Confirmation of the Tenderer that the commission/ remuneration, if any, payable to his agents/ representatives in India, may be paid by BHEL in Indian Rupees only.
- 2.2 Tenderers of Indian Nationality shall furnish the following details in their offers:
  - 2.2.1 The Bidder(s)/ Contractor(s) of Indian Nationality shall furnish the name and address of the foreign principals, if any, indicating their nationality as well as their status, i.e. whether manufacturer or agents of manufacturer holding the Letter of Authority of the Principal specifically authorizing the agent to make an offer in India in response to tender either directly or through the agents/ representatives.
  - 2.2.2 The amount of commission/ remuneration included in the price (s) quoted by the Tenderer for himself.
  - 2.2.3 Confirmation of the foreign principals of the Tenderer that the commission/ remuneration, if any, reserved for the Tenderer in the quoted price(s), may be paid by BHEL in India in equivalent Indian Rupees on satisfactory completion of the Project or supplies of Stores and Spares in case of operation items.
- 2.3 In either case, in the event of contract materializing, the terms of payment will provide for payment of the commission/ remuneration, if any payable to the agents/ representatives in India in Indian Rupees on expiry of 90 days after the discharge of the obligations under the contract.
- 2.4 Failure to furnish correct and detailed information as called for in paragraph 2.0 above will render the concerned tender liable to rejection or in the event of a contract materializing, the same liable to termination by BHEL. Besides this there would be a penalty of banning business dealings with BHEL or damage or payment of a named sum.

---x---

Annexure-B

This format is applicable only to Indian Suppliers/ Agents supplying indigenous portion of Foreign Purchases.

\* In all other cases, extant guidelines of SEARP, 2010 are to be followed.

SEARP (SRF) Clause No	Detail
	<b>Name &amp; address of the firm</b>
1.0	<b>Products/ Systems / Services being considered for</b>
2.0	<b>General Information</b>
2.2	Name of Chief Executive
2.3	Details of authorized signatory
3.0	<b>Ownership Information</b>
3.1	Type of firm
3.2	Nature of Business <ul style="list-style-type: none"> <li>• Attach <b>authorization letter</b> and <b>agency agreement</b> from Principal ( from whom capital equipment is procured)</li> <li>• Attach copy of declaration from Foreign Principal for <b>total guarantee/ warranty of indigenous supplies</b></li> </ul>
3.3	Year of establishment
3.4	Year of commencement of business
4.0	<b>Registration particulars</b>
4.1	Permanent Account No.
4.2 / 4.3	Sales Tax / TIN no
4.6	Service tax no. (in case of E&C)
5.0	<b>Organisational strength</b>
6.0	<b>Other particulars</b>
6.1	If the company is already registered with other units
6.2	Directors/ Partners, if related to any BHEL Employee
6.9	If any Ex BHEL Personnel employed by the Company
6.12	Details of pending legal issues with BHEL
6.13	Bank Account information
9.0	<b>Financial information</b>
9.6	Sales/ Turnover details of last 3 years (or from the date of incorporation, whichever is less )

---X---

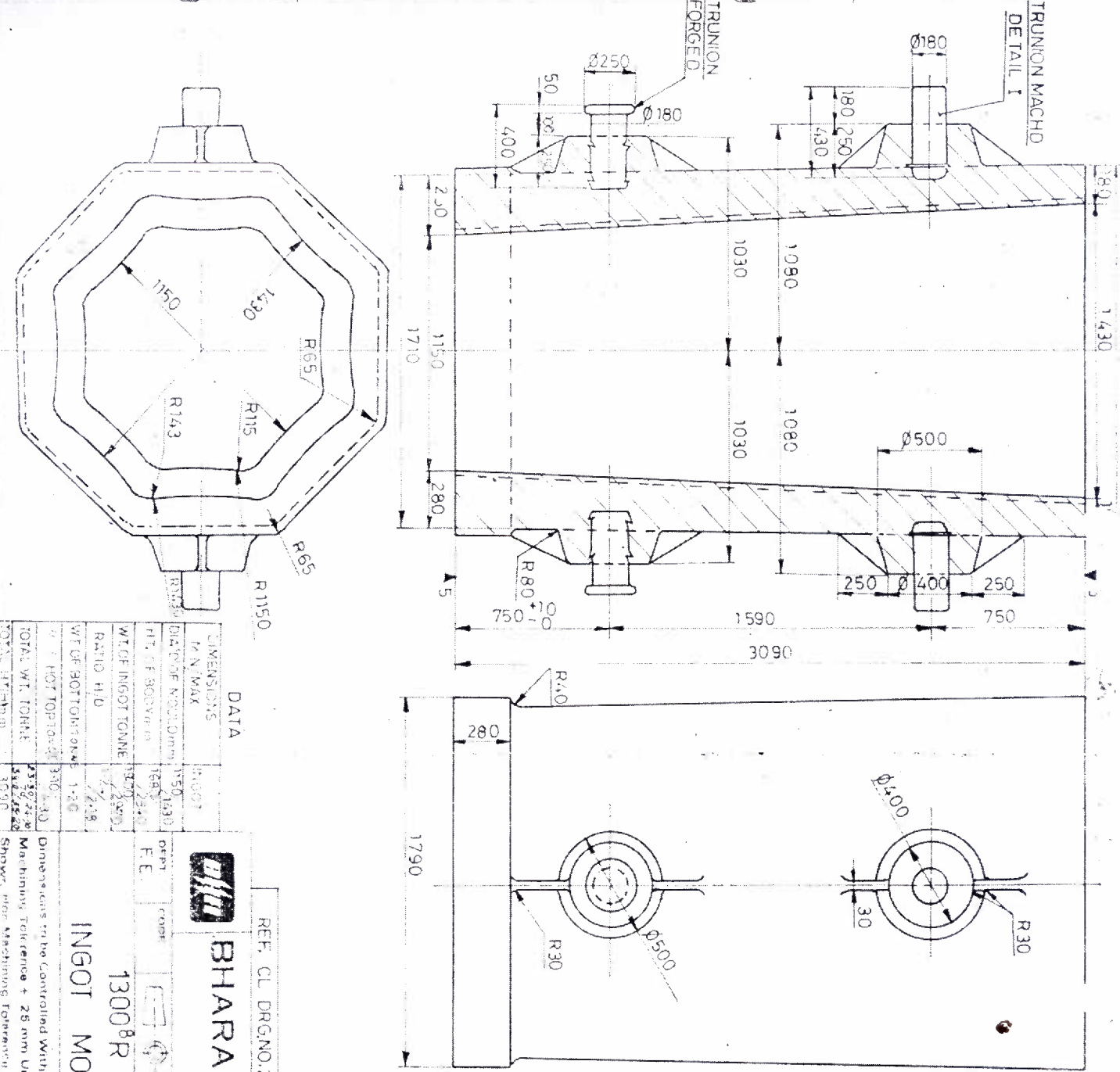

INCLINATION 45.3mm P METER

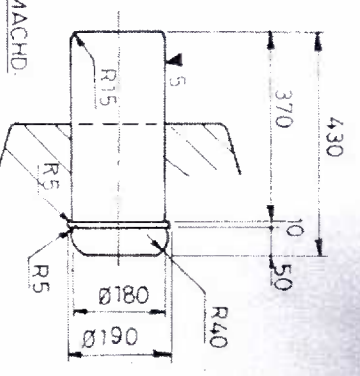

**Note**  
 Composition requirements as per SFIL technology  
 TR = 0.005%, max  
 Arsenic = 0.0005%, max  
 Lead = 0.0005%, max  
 Rayon  
 20/11/11

SCALE 1:10  
 TOTAL WT = 26.0 T APPROX.

MATERIAL	CL WITH COMPOSITIONS
8 CHROMIUM	< 0.50 %
7 NICKLE	< 0.50 %
6 TIN	< 0.50 %
5 PHOSPHORUS	< 0.120 %
4 SULPHUR	< 0.050 %
3 MANGANESE	0.4 TO 0.5 %
2 SILICON	1.4 TO 2.0 %
1 TOTAL CARBON	3.6 TO 4.0 %

COMPOSITION OF MATERIAL/REF. CL/BHEL/53

REF. CL DRGNO.272 FOR 1300<sup>8</sup>R INGOT MOULD

**BHARAT HEAVY ELECTRICALS LTD.**  
 UNIT: C.F.F.P., HARDWAR

DIMENSIONS	
MAX DIA	1430
MIN DIA	1150
HT OF BODY	1710
HT OF BOTTOM	280
WT OF INGOT TONNE	26.0
RATIO H/D	1.20
WT OF BOTTOM TONNE	1.5
HT OF HOT TOP	330
TOTAL WT. TONNE	27.5
TOTAL HT. mm	3090

**INGOT MOULD**

SCALE 1:20

WEIGHTING: 26.0 T

DATE: 11/09

APPROVED: [Signature]

DRAWN: AEDD KB

CHECKED: [Signature]

DATE: 22/3/11

NO. OF SHEETS: 01

SIZE: A1

The information on this document is the property of BHARAT HEAVY ELECTRICALS LIMITED. It must not be used directly or indirectly in any way detrimental to the interest of the company.

23231010

Ref. Dwg. No.

Rev. & Date

Factory No.

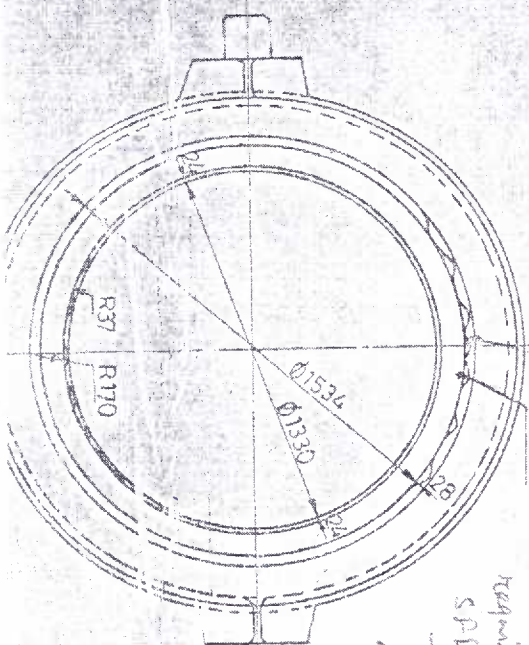
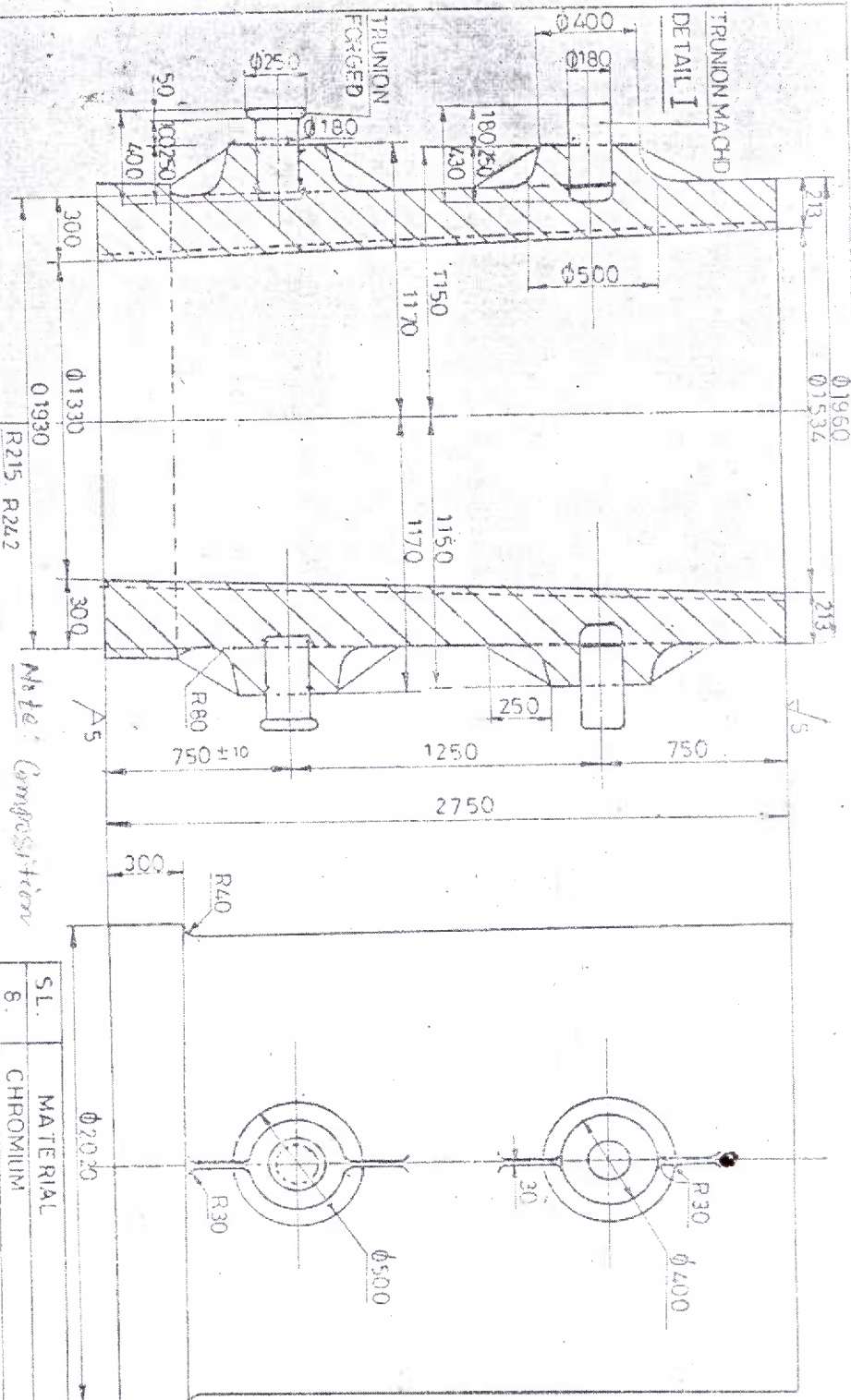

Note: Composition requirement as per SPLL Technology

Tin = 0.005% max  
Arsenic = 0.005% max  
Lead = 0.0003% max

DATA

PERMISSIBLE MIN. VALUE	MAX. VALUE
LOADING OF MOULDING	1300/750
WT OF BODY MM	800/5500
WT OF CORE TONE	2500/3100
RATIO H/D	1/35/1/74
WT OF BOTTOM CORE	1-20
WT OF HOT TOP	350/600
TOTAL WT TONNE	2870/3670

S.L.	MATERIAL	COMPOSITION OF MATERIAL
1.	CHROMIUM	C.I. WITH COMPOSITIONS
2.	NICKLE	≤ 0.50%
3.	TIN	≤ 0.50%
4.	PHOSPHORUS	≤ 0.50%
5.	SULPHUR	≤ 0.50%
6.	MANGANESE	0.4 TO 0.5%
7.	SILICON	1.4 TO 2.0%
8.	TOTAL CARBON	3.6 TO 4.0%

**BHARAT HEAVY ELECTRICALS LTD.**  
UNIT: C.E.P. HARDWAR.

INGOT MOULD

1400<sup>24</sup>R

Dimensions to be Correct ± within limits as shown  
Machining Tolerance ± 0.10 mm unless otherwise

DEPT.	SCALE	WEIGHT (KG)	REF TO ASSY DRG.
C.E.	1:20, 1:10	270 T	23231010
DATE	SIGN	DATE	DATE
14/11/10	AEDD		
CHECKED	DATE	SIGN	DATE
DRAWING NO.	1518		
02-149			

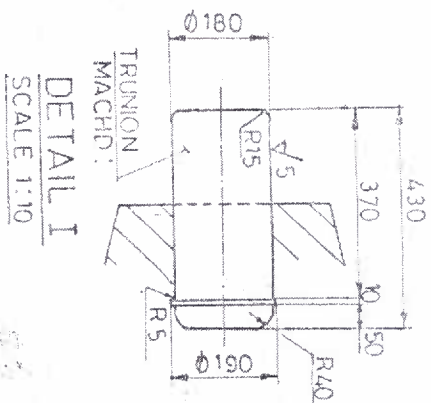

SCALE 1:10

REF: CLDRG NO 349 FOR 1400<sup>24</sup>R  
INGOT MOULD.

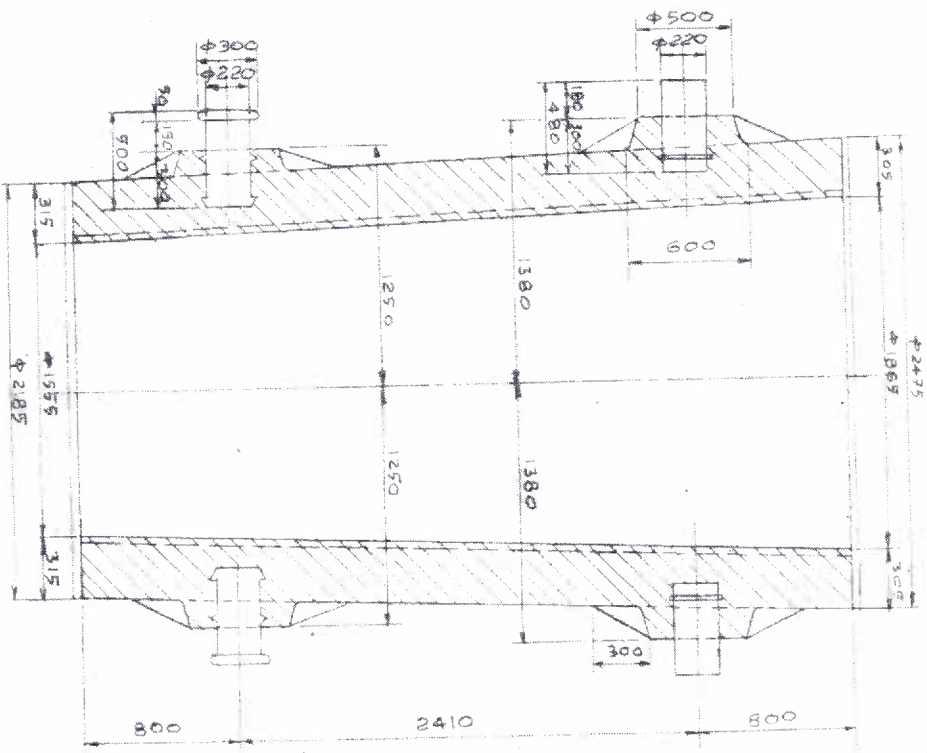

SCALE: 1:20

COMPOSITION OF MATERIAL

S.No	CAST IRON	WITH COMPOSITION	CONDITION OF DELIVERY
8	CHROMIUM	≤ 0.050%	STRESS - RELIEVED
7	NICKEL	≤ 0.050%	
6	Iron	≤ 0.050%	
5	PHOSPHORUS	≤ 0.120%	
4	SULPHUR	≤ 0.050%	
3	MANGANESE	0.14 to 0.5%	
2	SILICON	1.4 to 2%	

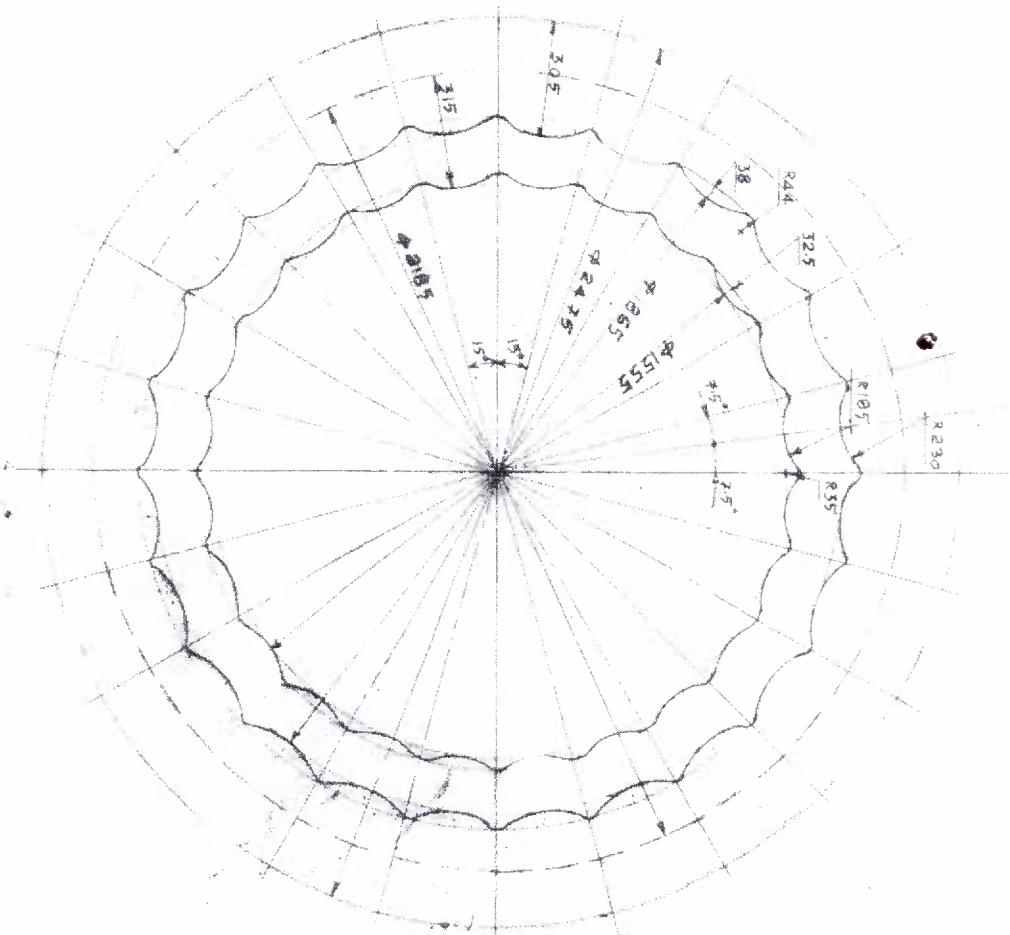

VIEW-A  
SCALE: 1:10

Note: Composition requirement as per SII Technology

TiL = 0.0051 Max  
Mn = 0.0051 Max  
Lead = 0.0031 Max

3/23/12

	<b>BILLY HEAVY INDUSTRIES LTD.</b> 100, CENTRAL ROAD, CHENNAI - 600 008
PART DESIGN DATE: 10/01/12 DRAWN BY:	INGOT MOULD #1702
CHECKED BY:	DATE: 03-20-12
APPROVED BY:	DATE: 03-20-12

①