

PART A - QUALIFYING CRITERIA

ITEM DESCRIPTION: DESIGN, MANUFACTURE, SUPPLY, ERECTION AND COMMISSIONING OF TUBE PACKING FIXTURE TO THE ONLINE TUBE FINISHING SYSTEM FOR COLD MILL SSTP ALONG WITH ALL ACCESSORIES.

This document deals with requirements for submitting offers and executing the order on placement of Purchase order / Contract for the subject item. The equipment under this specification are required for Tube Finishing Line in Cold Mill for seamless steel tubes being manufactured in SSTP/BHEL, having diameter between 19 and 133 mm and thickness between 2 and 12.5 mm and length between 3 and 20 meters.

The BIDDER has to compulsorily meet the following requirements to get qualified for considering the technical offer.

The BIDDER / VENDOR has to necessarily provide the following details, for making an assessment of the firm's capability and competency: [The BIDDER is expected to give complete details against each clause in the table given below and wherever necessary an additional sheet may be attached (giving clear reference number) to cover the required details]

SL No.	REQUIREMENTS	VENDOR'S RESPONSE
1	Only those vendors who have experience in design and manufacturing of machines/special purpose machines with necessary infrastructure to fabricate and testing facilities at their works are eligible to participate in this tender and quote. They should have supplied and commissioned minimum 3 nos of machines with total design, manufacture, supply, erection and commissioning in the past ten years and such items should be working satisfactorily for a minimum period of 3 years after commissioning as on the date of opening of this Tender. (However, if such type of machine is already supplied to BHEL, then that should be working satisfactorily for a minimum continuous period of 2 years after commissioning as on the date of opening of this Tender.)	
2	Details of Design Set-Up and Technology Back-Up assured for the PRINCIPAL Equipment Maker. Details on International Standards followed in Design of the Equipment	
3	Details of Quality System followed (Kindly furnish the salient aspects of the QA system followed)	
4	Name and postal address of the customer or company where the machine with all accessories supplied, erected and commissioned.	
5	Name and designation of the contact person of the customer.	
6	Phone, FAX no and email address of the contact person of the customer.	
7	Month and Year of commissioning of the machine.	
8	Along with the Technical offer, the Vendor should submit one Performance certificate from the customer for the satisfactory performance of the machine supplied to them.	

A. KARUPPIAN
Manager

SL.No.	REQUIREMENTS	VENDOR'S RESPONSE
9	BHEL reserves the right to verify the information provided by vendor. In case the information provided by vendor is found to be false/ incorrect, their offer shall be rejected even though it is technically found to be suitable.	
10	The BIDDER / VENDOR shall submit the offer in TWO PARTS – “Part I - Technical and commercial bid”, and “Part II - Price bid”. The Technical Offer – Part I, shall be in line with the BHEL Technical Specifications and the Guidelines or Annexure mentioned, wherever applicable. This shall also include commercial conditions, list of spares and consumables for 5 years of trouble free operation, List of optional items and price list of all the items with the price blanked.	
11	The BIDDER/VENDOR to furnish Reference List of Customers, with full address, details of contact person, where above said machine has been supplied in the past.	
12	Details of such machine supplied to other BHEL units, if any. (Year of commissioning and performance are to be furnished.)	
13	Details on SERVICE-AFTER-SALES Set-Up in India including the Address of Agents / Service Centers in South India.	
14	The Offer shall contain a comparative statement of Technical Specifications given by BHEL and the Offer Details submitted by the Bidder, against each clause. A just ‘CONFIRMED’ or ‘COMPLIES’ or ‘YES’ or ‘NO-DEVIATION’ or similar words in the technical comparative statement <u>may lead to disqualification of the Technical Offer.</u> Where specification requirements are not met, the reason for this shall also be indicated point wise.	
15	The BIDDER / VENDOR shall assure a continuous support for SPARES and SERVICE for TEN Years, from the date of commissioning of the equipment at BHEL Works.	
16	The Technical Offer, wherever applicable, shall be supported by Product Catalogue and Data Sheets in ORIGINAL and complete technical details of ‘Bought-Out-Items’ with copies of Product Catalogue and Selection Criteria	
17	The points confirmed by the supplier based on the clarifications sought for the original offer shall be incorporated in the revised offer wherever applicable. Pl. confirm	
18	The bidder/Vendor shall provide a complete list of out sourced electrical, electronic and mechanical components with Source name, Specification and drawings	<p style="text-align: right;"> A. KARUPPIAN Manager Cold MHI Mechanical Maintenance SSTP, BHEL, TRICHY-14 </p> 

PART B - TECHNICAL REQUIREMENTS / SPECIFICATIONS**ITEM DESCRIPTION: DESIGN, MANUFACTURE, SUPPLY, ERECTION AND COMMISSIONING OF TUBE PACKING FIXTURE TO THE ONLINE TUBE FINISHING SYSTEM FOR COLD MILL SSTP ALONG WITH ALL ACCESSORIES.**

ANNEXURE TO INDENT NO: S – 447 – 2 - 0084

SL .No.	REQUIREMENTS	VENDOR'S RESPONSE
A	Seamless steel tube manufactured and NDE tested travels on a conveyor, color coding, stenciling and rust preventive oil coating system and will be ejected automatically from the conveyor and rolled down a sloping table to a trough where the tubes will be collected in to bundles and strapped together and moved for shipment. The collected bundles must form a Hexagonal shape which must be aided by the packing fixture. The attached sketch shows the general arrangement of the fixture as proposed and detailed below.	
B	Design	
B.1	<p>A Preliminary conceptual design is shown in annexure - A, which shows the general arrangement of the fixture as proposed and detailed below.</p> <p>A set of 6 such fixtures to be aligned to form the bundling system.</p> <p>Two sides of the hexagon are formed by the fixed arms, Opposite 2 sides are guided by the movable arm, the fifth one guide the fifth side formed after filling half the trough. After filling half of the bundle, the fixture must be lowered for each tube level, the fifth guide will be advanced to provide gap required for filling the next layer of tube. This cycle will be continued till all the rows of the tubes are filled. Then the bundles are strapped using steel strip and crimping tool. The columns on the left along with the left side guides are moved out using pneumatic cylinders. The bundle is freed for lifting by crane. Again after bundle is moved, the columns are moved in to initial position for next bundle.</p> <p>The width of a side of the hexagon will vary from 200 to 600 mm. The sliding mechanisms shall ensure this stroke length.</p> <p>The supplier shall explore further and develop the design with dimensioned drawings, List of bought out items and propose the method of manufacture and testing.</p>	

A. KARUPPIAN
 Manager

Cold Mill Mechanical Maintenance
 SSTP. BHEL, TRICHY-14

SL.No.	REQUIREMENTS	VENDOR'S RESPONSE
C	Job Parameters	
C.1	Tube sizes : OD 19 to 133 mm. Thickness of tubes: : 2 mm to 12.5 mm Length of tubes : 3 to 22 meters. Bundle weight : 1.0 to 5.0 tons No. of tubes : depends on the size and length within the above weight range. Rate of output : 1000 tubes per shift of 8 Hrs. (operation in 3 shifts)	
D	Scope of supply	
D.1	The scope of supply shall include design procurement manufacture and supply of the items and installation, commissioning and performance proving for a defined period of time. The equipment may essentially consist of: Base structure, Hexagon forming module, necessary, actuators, motors, control valves, switch gear, Electrical panel, piping, Cabling etc. and Strapping system. Power supply with 440V, 3 phase and Compressed air At 5kg/sq.cm pressure will be made available from BHEL side.	
E	General requirements:	
E.1	The layout and footprint area shall be described using drawings to identify space requirement and feasibility of incorporating in the existing set up. This shall be submitted with the offer	
E.2	Operating instruction / maintenance manual to be supplied along with relevant drawings.	
E.3	Recommended spares for the smooth running of the system for minimum 2 year period shall be offered.	
E.4	The integration of the Packing fixture with our existing roll down table must be carried out.	
E.5	Existing Tube feed conveyor and roll down table are to be used to operate the offered system and suitability of our present facility has to be assessed by the vendor and confirm its compatibility without any problem for continuous operation. If the existing roll down table and tube conveyor is not suitable the same should be communicated with reason.	
E.6	Hydraulic system: Hydraulic pump shall be Vane/Variable piston pump from Parker/Rexroth make. All valves and accessories are from Parker/Rexroth make. All cylinders are from Parker/Rexroth make.	
		A. KARUPPIAN Manager 

SL. No.	REQUIREMENTS	VENDOR'S RESPONSE
E.7	Stands: Tube feed conveyor and roll down table are not included in the scope and is available in the existing system.	
E.8	QAP: Supplier shall prepare quality plan covering major items indicating critical quality characteristics, method of measurement, reference standard and acceptance norms and submit to BHEL before starting the manufacturing activities.	
E.9	Tools for Erection: Tools and accessories required for erection and commissioning of the total system and proving the performance of the m/c at SSTP is supplier's scope	
E.10	Proposed Electrical system consisting of Power Distribution, Control Section, various interlocks, PLC, Panels wiring and make of major components are to given to us to get our approval before manufacture.	
E.11	Electrical system: Suitable to operate with 415 volts, 3 phases, 50 Hz power supply and all electrical controls to operate with 230V AC, and 24 V DC for solenoid operations.	
E.12	Electrical panels: Should be of power section, control section and operator desk. Processed tube counter unit to be provided at the operator desk.	
E.13	VFD should have a capacity to give max torque at lower speeds less than 10% of rated.	
E.14	Electrical components: All internals of panels should be of SIEMENS / ABB make switch gears. Motors & VFD should be ABB / SIEMENS make only. PLC: ABB / SIEMENS / SCHNEIDER	
E.15	Drawing preparation: All the relevant drawings, assembly drawing, complete part drawing, structural drawing are to be submitted for SSTP/BHEL approval before starting the manufacture. Complete design values dimensions and the working performance of the machine is binding on the supplier only.	
E.16	Documentation: Operation and maintenance manual including all the bought out items details, seals, electrical circuits, PLC ladder logics and details of bill of materials are to be given in 4 sets hard copy and 1 soft copy in CD.	
E.17	Drawing Submission: All the relevant drawings, assembly drawing, complete part drawing, structural drawing are to be submitted for SSTP/BHEL in 3 sets hard copy Xerox/ blue print and soft copy in CD auto cad 2008 version as per BHEL layer enclosed. Pneumatic and hydraulic circuit drawing with BOM & quantity to be submitted attaching relevant catalogue.	
E.18	Delivery: Overall delivery period should not be more than 10 months. Drawings shall be approved within 20 days from the receipt date if they are correct in all respects.	<p style="text-align: right;">A. KARUPPIAN  Manager</p>

SL. No.	REQUIREMENTS	VENDOR'S RESPONSE
E.19	Inspection: Stage inspection at suppliers work will be carried out by SSTP/BHEL during manufacture and also at assembly stage before dispatch.	
E.20	Erection: Erection has to be carried out by the supplier within 30 days including electrical cabling PLC installation, testing and commissioning of equipment after BHEL/SSTP giving clearance for erection. Civil foundation and grouting will be done by SSTP/BHEL. Foundation drawing to be given by supplier in advance considering the loading pattern. Only flat shop floor will be given to the supplier. Erection by anchor fastening method. Supply of required anchor fasteners, drilling and fixing is supplier's scope. Only cable trench will be made in advance based on suppliers G.A. drawing or civil drawing.	
E,21	PLC system programming software and ladder logic diagram are to be provided including wiring diagram of all electrical control schemes. Training on Electrical system is to be arranged at supplier's works.	
F	Prove out	
	The system performance shall be checked at BHEL after installation on a set of tubes of 3 different Diameters covering the entire range of tube sizes. Functioning of the system to be demonstrated for a period of at least 3 shifts continuously.	
G	Service	
G.1	Service shall be provided by the supplier during guarantee period and also later through AMC. The system supplied must be supported by way of spares, availability and service for a minimum period of 10 years.	
H	List of spares	
H.1	List of spares with part identification no. (Tools, Mechanical, Electrical & Electronics) to be maintained for ensuring continuous operation with least delay time shall be provided in the offer with price.	
I	Performance Guarantee	
	Guarantee. 24 months from the date of commissioning of the equipment	
J	Special note to vendor	
J.1	Vendors are requested to visit SSTP and assess the site condition before they give their bid. Without this, the bid submitted shall not be taken up for evaluation.	

A. KARUPPIAN
Manager

Old MHI Mechanical Maintenance
SSTP. BHEL. TRICHY-14

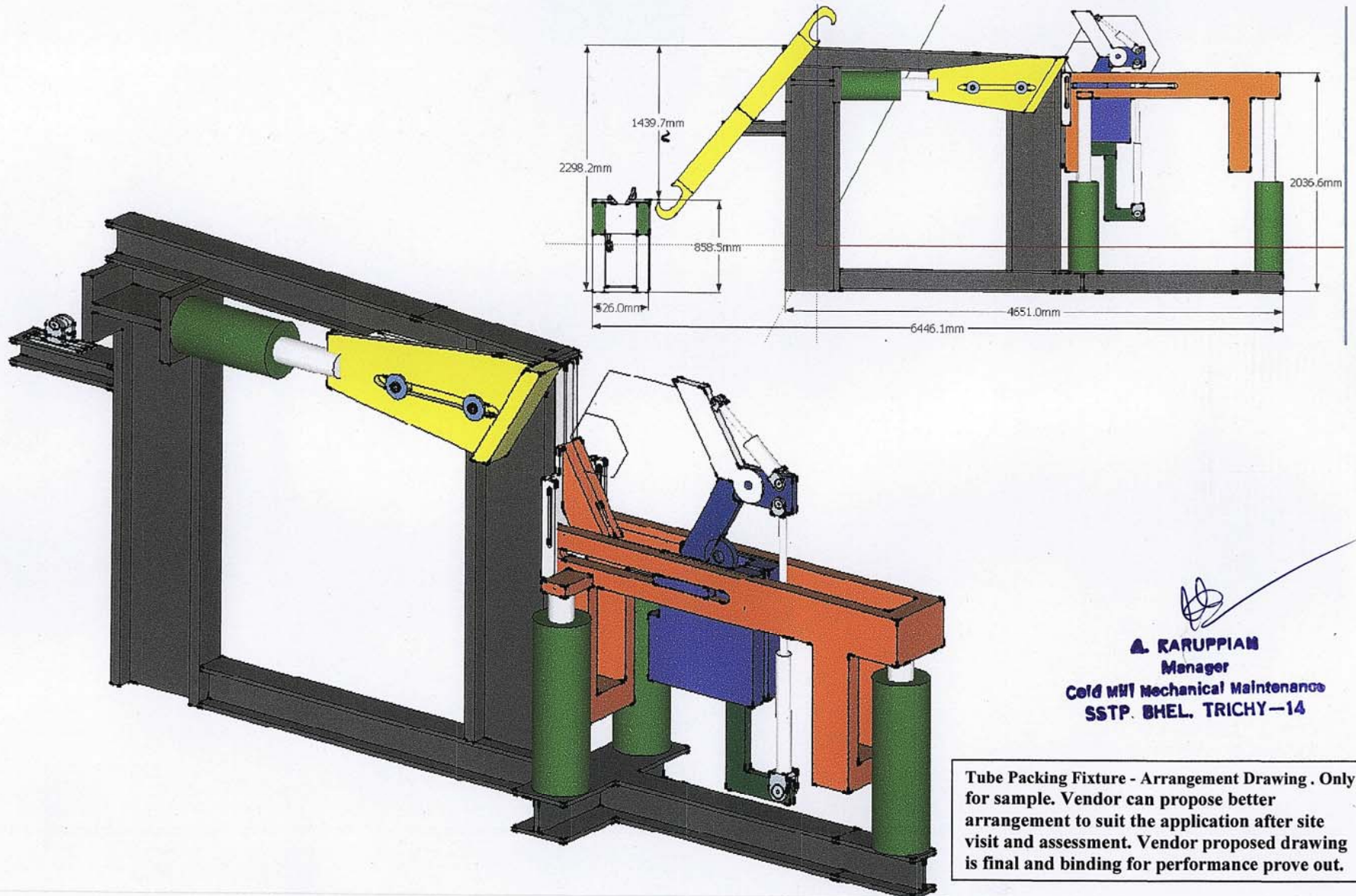

A. KARUPPIAM
Manager
Cold MHI Mechanical Maintenance
SSTP, BHEL, TRICHY-14

Tube Packing Fixture - Arrangement Drawing . Only for sample. Vendor can propose better arrangement to suit the application after site visit and assessment. Vendor proposed drawing is final and binding for performance prove out.



An ISO 9001 Company

Bharat Heavy Electricals Limited
(Seamless Steel Tube Plant)
Tiruchirappalli-620014, Tamil Nadu, India

ANNEXURE-C

COMMERCIAL TERMS AND CONDITIONS APPLICABLE FOR OPEN TENDER

INSTRUCTIONS TO THE BIDDERS:

1.0 QUOTATIONS

Bidders shall submit the offer in **TWO INNER ENVELOPES** as indicated below which shall be sealed in one outer envelope.

Envelope I This sealed envelope should contain all the copies of technical bid together with un-priced commercial bid. This envelope should be clearly marked "**Part I - Technical and Un-priced commercial bid**", indicating Tender No., Due Date and Address & Reference of the Bidder.

Envelope II This sealed envelope should contain **price details**. This envelope should be clearly marked "**Part II - Price bid**", indicating Tender No., Due Date and Address & Reference of the Bidder.

Both the envelopes (Part I & II) shall be put in one cover, duly sealed, superscribing as Part I and Part II of Tender No., due date of opening and the address and reference of the Bidder.

The above offer should reach this office on or before the due date by 14.00 Hrs (IST).

Tender should not be addressed to any Individual's name but only by designation to:

**SENIOR MANAGER / PURCHASE
BHARAT HEAVY ELECTRICALS LIMITED
SEAMLESS STEEL TUBE PLANT
TIRUCHIRAPALLI - 620 014
TAMIL NADU, INDIA**

Tenders should be free from **CORRECTION AND ERASURES**, Corrections if any, must be attested. All amounts shall be indicated both in words as well as in figures. Where there is difference between amount quoted in words and figures, amount quoted in words shall prevail.

Offers should be in **ENGLISH** and accompanied by detailed technical literature, catalogue and detailed dimensional drawings in **ENGLISH** or otherwise, the offers will not be considered.

2.0 PART I (TECHNICAL & UN-PRICED COMMERCIAL BID)

2.1 Technical

This part shall include / indicate the following:

- 2.1.1. Offer should contain complete scope of supply with all technical details, specifications, delivery and other commercial terms and conditions.

- 2.1.2. Point by point confirmation for the Technical Specification enclosed is to be provided. If there are any deviations, the same should be clearly specified. Offers received without confirmation to our specification will be rejected.
- 2.1.3. List of customers to whom same or similar equipment have been supplied along with performance certificates to be enclosed.
- 2.1.4. Relevant catalogues to be attached
- 2.1.5. List of spares parts (with part numbers) for two years operation and maintenance should be attached.
- 2.1.6. Information on shipping weight and cubage (length, width & height) to be provided.
- 2.1.7. Offers shall be submitted by the Original Equipment Manufacturer. In case of foreign bidder, the Principal's offer should be enclosed.**

2.2 Un-Priced Commercial

This part shall include / indicate the following:

- 2.2.1. Acceptance of commercial terms and conditions by the bidders
- 2.2.2. Port of shipment / Station of despatch
- 2.2.3. Terms of payment
- 2.2.4. CFR price upto Chennai port (for foreign bidders).
- 2.2.5. FOR /BHEL, Tiruchy price along with freight charges upto BHEL, Tiruchy
Indicated separately (for Indian bidders)
- 2.2.6. Taxes, Service tax & duties including cess applicable.
- 2.2.7. Delivery Schedule
- 2.2.8. Offer validity
- 2.2.9. Country of origin
- 2.2.10. Percentage of agency commission if any along with a copy of Agency agreement.
The CFR prices quoted shall include the agency commission.
- 2.2.11. A copy of "Un-Priced Part II" i.e., a copy of the Price Bid **without the price details** to be enclosed.

3.0 PART II (PRICE- BID)

This part should contain the schedule of price particulars and to be co-related to the technical details provided in Part I.

4.0 OPENING OF TENDERS

The Part I - Technical & Un-priced commercial bid alone would be opened on the Tender opening date.

The Part II - Price bid of Technically suitable Bidders alone would be opened. The Technically suitable Bidders would be informed about the Price Bid opening date. Clarifications if any required by BHEL for Technical evaluation / commercial evaluation would be sought from Bidders before opening of Part II - price bid.

5.0 GENERAL

- 5.1. Equipment offered shall be "New". Re-built / Re-conditioned / Used equipments will not be accepted. Incomplete offers will not be considered for further processing.
- 5.2. **Fixed price:** Prices quoted by the bidder shall be fixed and not subject to any escalation whatsoever during the period of bid validity and execution of the Purchase Order. A bid submitted with an adjustable price will be treated as non-responsive and rejected. Prices shall be written in words and figures. In the event of difference, the price in words shall be valid and binding. Unit prices shall be considered correct in the event of any discrepancy with regard to total price.

- 5.3. **Bid currency:** Indian bidders should submit the prices only in Indian Rupees. Foreign bidders may submit their bid in their home currency, which should be clearly indicated in the un-priced commercial bid as well as in the price bid.
- 5.4. **Terms of Delivery:** Bidders are required to quote their best delivery period. Foreign Bidders should submit their offer for net **CFR / Chennai Seaport / Airport**. Freight charges upto Chennai port to be indicated separately. Indian Bidders should submit their offer for **FOR/ BHEL, Tiruchy basis**. Freight charges from Supplier works to BHEL, Tiruchy to be indicated separately. Delivery from the date of Letter of Intent / Purchase Order to be mentioned in the offer.
- 5.5. **Taxes and Duties :** All Taxes and Duties payable as extra to the quoted price should be specifically stated in offers along with CST & TIN No / Tariff No. etc., failing which the purchaser will not be liable for payment of such Taxes and Duties. Our TIN No. 33243560005, TNGST No. 3560005, CST. No. 239383 Dt. 11-06-1991 & BHEL ECC No. AAACB4146PXM012, Assessment circle Tiruverambur
- 5.6. **Validity :** The offers for main equipment and spares shall be kept open for acceptance for a period of **180 days (one hundred and eighty days)** from the date of opening of the tender (Part I).
- 5.7. The bidder to provide Business Information Report incorporating the rating of the company by international credit rating agencies, viz., **DUNS** number of M/s DUN & Bradstreet (D&B) etc., along with your technical offer.
- 5.8. **Indian Agent & Agency commission:**
- 5.8.1. BHEL shall deal directly with foreign vendors, wherever required, for procurement of goods. However, if the foreign principal desires to avail of the services of an Indian agent, then the foreign principal should ensure compliance to regulatory guidelines – which require mandatory submission of an Agency Agreement.
- 5.8.2. It shall be incumbent on the Indian agent and the foreign principal to adhere to the relevant guidelines of Government of India, issued from time to time.
- 5.8.3. The Agency Agreement should specify the precise relationship between the foreign OEM / foreign principal and their Indian agent and their mutual interest in the business. All services to be rendered by agent / associate, whether of general nature or in relation to the particular contract, must be clearly stated by the foreign supplier / Indian agent. Any payment, which the agent or associate receives in India or abroad from the OEM, whether as commission or as a general retainer fee should be brought on record in the Agreement and be made explicit in order to ensure compliance to laws of the country.
- 5.8.4. Any agency commission to be paid by BHEL to the Indian agent shall be in Indian currency only.
- 5.8.5. Tax deduction at source is applicable to the agency commission paid to the Indian agent as per the prevailing rules.

- 5.8.6. In the absence of any agency agreement, BHEL shall not deal with any Indian agent (authorised representatives / associate / consultant, or by whatever name called) and shall deal directly with the foreign principal only for all correspondence and business purposes.
- 5.8.7. The “Guidelines for Indian Agents of Foreign Suppliers” enclosed at annexure – ‘A’ shall apply in all such cases.
- 5.8.8. The supply and execution of the Purchase Order (including indigenous supplies/ service) shall be in the scope of the OEM/ foreign principal. The OEM/ foreign principal should submit their offer inclusive of all indigenous supplies / services and evaluation will be based on ‘total cost to BHEL’. In case OEM/ foreign principal recommends placement of order(s) towards indigenous portion of supplies/ services on Indian supplier(s)/ agent on their behalf, the credentials/ capacity/ capability of the Indian supplier(s)/ agent to make the supplies/ services shall be checked by BHEL as per the extant guidelines of Supplier Evaluation, Approval & Review Procedure (SEARP), before opening of price bids. In this regard, details may be checked as per Annexure-B (copy enclosed). It will be the responsibility of the OEM/ foreign principal to get acquainted with the evaluation requirements of Indian supplier/ agent as per SEARP available on www.bhel.com.

The responsibility for successful execution of the contract (including indigenous supplies/ services) lies with the OEM/ foreign principal. All bank guarantees to this effect shall be in the scope of the OEM/ foreign principal.

- 5.9. **Short shipment / Warranty replacement:** In case of any short shipment in the main equipment / spares, customs duty levied on such supplies, shall be borne by the supplier. Any warranty replacement during the warrantee period shall be on FOR/ BHEL, Tiruchirappalli, basis.
- 5.10. **Inspection & Testing:** All goods shall be subject to inspection by BHEL or its authorized representatives at supplier’s works or at BHEL stores. The supplier will not charge for the facilities provided for inspection of goods. In case of machine tools, the machine would be inspected and proved at supplier’s works prior to dispatch however; final inspection and acceptance of the machine will be carried after installation of the machine at BHEL, Tiruchirappalli.
- 5.11. **Cenvat & VAT credit :** (for Indigenous Bidders only) The quotation must indicate Tariff item number and rate of Excise Duty applicable. The original Excise Duty Gate Pass will be required to be furnished in case it is charged to BHEL. If the bidder is availing Cenvat credit for his input materials, the effect of proforma credit should be passed on to the purchaser.
- 5.12. **Packing:** The Supplier shall arrange for packing suitably in all respects considering the peculiarity of the material involved for normal transport by sea / air / rail / road and suitably protected against effect of tropical salt laden atmosphere in the event of shipment being delayed at ports.
- 5.13. **Salient points of HSE (Health Safety & Environment)** that are to be considered while submission of offer are:
- Consumption benchmarks related to output shall be provided wherever applicable for key input resources (energy/fuel/chemicals)

- Competency requirements for operation, maintenance and calibration, if any, shall be communicated
 - If any hazardous chemicals as per MSIHC (Manufacturing, Storage and import of Hazardous Chemicals) Rules 1989/94/2000 are used, the MSDS shall be provided, along with On site & Off site emergency plan (as applicable)
 - The noise level at operator level shall be within 90 dBA
 - OH&S (Occupational Health and Safety) control measures for safe working of machine as applicable shall be specified.
 - The machine / equipment shall be fitted with guard for rolling and moving parts and shall comply with applicable OH&S legislations and Factories Act 1948
 - The supplier shall submit the layout drawing of operating controls, displays etc. and operating instructions to enable ergonomics evaluation and approval
 - The recommended PPE (Personal Protective Equipment) for the equipment shall be furnished
 - Alarm system (both visual and audible) and Automatic switch off of the equipment shall be provided for any intrusion, overloading, short circuiting or any malfunctioning of the equipment
 - Details of all hazardous / harmful substances discharged as by-products / wastes during operations of the machine / equipment, such as fumes, gases, dust particles, aerosols UV/IR (Ultra violet / infra red) radiations, etc. shall be furnished, along with their concentrations and their TLV, (Threshold Limit Value).
 - Appropriate pollution control measures shall be proposed to keep the emissions from the machinery / processes within the prescribed limit as stated in Environment Protection Rules 1986.
 - All furnaces, process units, DG sets, paint booths, shot blasting chambers, etc shall be provided with stack(s) of sufficient height as per guidelines laid down in the Environment Protection Rules 1986.
 - Wherever industry specific standards are not available for control of pollutants, general emission standards shall be used
 - Chemicals banned due to their negative impact on the environment shall not be used in the process
 - Fuels with sulphur content less than 0.05% shall be proposed
 - Details regarding nature of waste generated and appropriate disposal practices available shall be provided, along with the operation procedure of the plant / process. Hazardous chemicals and flammable substances shall be transported only through authorized transporters and all safety practices as laid down in applicable legislative requirements such as Central Motor Vehicle Rules, Manufacture, Storage and Import of Hazardous Chemical 1989, etc. shall be followed
 - Primary materials used in the equipment shall be specified and they shall be eco – friendly
- 5.14. Evaluation of offers shall be on the basis of delivered cost (Net cash outflow to BHEL)
.FOR THIS PURPOSE IT IS PREFERABLE TO HAVE YOUR OFFER ON FOR/SSTP or CFR/CHENNAI basis,as the case may be.
- 5.15. BHEL also reserve its right to allow to the Public Sector Enterprises ordering and price preference facilities as admissible under the existing policy.
- 5.16. BHEL reserves its right to reject a tender due to unsatisfactory past performance in the execution of a contract at any of BHEL projects / units.
- 5.17. BHEL shall be at liberty to reject or accept any tender, part or in full, at their own

discretion and any such action is not liable for any question or claim against BHEL.

- 5.18. **BHEL reserves the right to go for a Reverse Auction (RA)** instead of Opening the submitted sealed bid, which will be decided after technical evaluation. Information and general terms and conditions governing RA are given below.

GENERAL TERMS AND CONDITIONS OF RA

Against this enquiry for the subject item/system with detailed scope of supply as per enquiry specifications, BHEL may resort to "REVERSE AUCTION PROCEDURE" i.e., ON LINE BIDDING ON INTERNET.

1. For the proposed reverse auction, technically and commercially acceptable bidders only shall be eligible to participate.
2. BHEL will engage the services of a service provider who will provide all necessary training and assistance before commencement of on line bidding on internet.
3. BHEL will inform the vendor in writing in case of reverse auction, the details of Service Provider to enable them to contact & get trained.
4. Business rules like event date, time, Start price, bid decrement, extensions etc. also will be communicated through service provider for compliance.
5. Vendors have to fax the Compliance form in the prescribed format (provided by Service provider) before start of Reverse auction. Without this, the vendor will not be eligible to Participate in the event.
6. BHEL will provide the calculation sheet (e.g., EXCEL sheet) which will help to arrive at "Total Cost to BHEL" like Packing & forwarding charges, Taxes and Duties, Freight charges, Insurance, Service Tax for Services and loading factors (for non-compliance to BHEL standard Commercial terms & conditions) for each of the vendor to enable them to fill-in the price and keep it ready for keying in during the Auction.
7. Reverse auction will be conducted on scheduled date & time.
8. At the end of Reverse Auction event, the lowest bidder value will be known on the network.
9. The lowest bidder has to Fax the duly signed Filled-in prescribed format as provided on case-to-case basis to BHEL through Service provider within 24 hours of Auction without fail.
10. Any variation between the on-line bid value and the signed document will be considered as sabotaging the tender process and will invite disqualification of vendor to conduct business with BHEL as per prevailing procedure.
11. In case BHEL decides not to go for Reverse Auction procedure for this tender enquiry, the Price bids and price impacts, if any, already submitted and available with BHEL shall be opened as per BHEL's standard practice.

- 5.19. **Force Majeure clause:** If at any time during the continuance of this contract the

performance in whole or in part by either party of any obligations under this contract shall be prevented or delayed by reason, of any war, hostilities, acts of the public enemy, civil commotion, sabotage, fires, explosions, epidemics, quarantine, restrictions or acts of GOD (hereinafter referred to as events) then provided notice of happening of any such events is given by either party to other within twenty one days from the date of occurrence thereof neither party shall reason of such events be entitled to terminate this contract nor shall either party have any such non performance and delay is resumed as soon as practicable after such events has come to an end or ceased to exist. If the performance in whole or part of any obligation under this contract is prevented or delayed by reason or any such event claims for extension of time shall be granted for period considered reasonable by the purchaser subject to prompt notification by the seller to the purchaser of the particulars of the events and supply to the purchaser if required of any supporting evidence. Any waiver of time in respect of partial instalment shall not be deemed to be a waiver of time in respect of remaining deliveries.

- 5.27 The correspondence exchanged against the tender from both tenderer and BHEL through email are considered as valid document legally though it is not signed. It is treated as valid confirmations made on behalf of the respective company and very much comes under the legal ambit of the business transaction and hence it is bidding on both the parties to the business.
- 5.28 Any transaction pertaining to the tender from both the parties of business done round the clock irrespective of the office or business hours of the companies, are valid legally and binding on both the parties. This applies to the extent only in such cases where deadline time for transaction is not specifically declared by either or both the parties to the business.
- 5.29 In case Letter of Intent (LOI) is issued through email, the PC generated time and date of mail shall be construed as the official time and date of release of LOI. In as much as this date is within the last date of validity given by the bidder the LOI is said to have been issued within the validity period and shall be bidding on both the parties to the business.
- 5.30 Bidders participating in the tender should declare in their technical bid that whether they have been black-listed / kept on hold for a specified period / given Business holiday for a specified period by any Public sector undertaking or Government departments. The reasons for such action with details and the current status of such hold shall be clearly furnished to BHEL. If no such details are mentioned in the offer then it will be construed that the subject bidder is not under any such hold. But at a later date if it comes to the notice of BHEL about any such hold under enforcement on the subject bidder, BHEL will have every right to reject the offer of such vendors at any point of time and also under any stage of the finalisation of the subject tender irrespective of the status of the subject bidder in that tender. Such bidders will not be permitted to participate in the further tender proceedings and will be communicated suitably. They will not be also considered for any on going tenders even if participated till the hold is officially lifted and confirmed in writing.
- 5.31 **Guarantee:** The equipment shall be guaranteed for a period of 24 months from the date of commissioning.

- 5.32 **Contract Execution Bank Guarantee (CEBG):** The successful tenderer shall furnish a Bank Guarantee, from an Indian Bank approved by BHEL in the format enclosed, for 5% of the Letter of Intent value (FOR Dispatching station value – Excluding taxes, duties, freight & Bharat Heavy Electricals Limited TIRUCHIRAPPALLI CAPITAL PURCHASE insurance – for Indian bidders) & (FOB/FCA value – Excluding freight & insurance – for foreign bidders) confirming that the order will be executed as per the terms and conditions and this should be valid till final dispatch date (LR/GR/BL/AWB) with additional 2 months claim period. Purchase Order & Letter of Credit will be processed only after receipt of CEBG. The CEBG is to be furnished within 3 weeks from the date of Letter of Intent.
- 5.33 **Performance Bank Guarantee (PBG):** The supplier shall furnish a Bank Guarantee, from an Indian Bank approved by BHEL in the format enclosed, for 10% of the Purchase Order value (FOR Dispatching station value – Excluding taxes, duties, freight & insurance – for Indian bidders) & (FOB/FCA value – Excluding freight & insurance – for foreign bidders) valid for period of 24 months from the date of commissioning & acceptance of the equipment at BHEL, Tiruchirappalli, with additional claim period of 2 months.

Formats for execution of Bank Guarantees:

Important Note:- The formats for execution of Bank Guarantees (both CEBG & PBG) shall be kept valid to cover the period of BG plus an additional claim period of two months. The Bank Guarantee bonds (BG) are to be submitted on non-judicial stamp paper of Rs. 100/- and should be only from any one of the below mentioned Banks,

(1) State Bank of India, 2) State Bank of Hyderabad, 3) State Bank of Travancore, 4) Canara Bank, 5) Bank of Baroda, 6) Punjab National Bank, 7) Deutsche Bank AG, 8) HDFC Bank Ltd, 9) Standard Chartered Bank, 10) CITI Bank N.A., 11) ABN AMRO Bank N.V. 12) ICICI Bank Ltd. 13) IDBI Ltd. 14) The Hongkong and Shanghai Banking Corporation Ltd. 15) Syndicate Bank. 16) State Bank of Mysore. 17) State Bank of Maharastra. 18) UCO Bank. 19) Allahabad Bank. 20) Andhra Bank. 21) Corporation Bank. 22) Dena Bank 23) Union Bank of India. 24) United Bank of India. 25) Vijaya Bank. 26) Axis Bank (Unit Trust of India). 27) Bank of Maharastra. 28) Bharat Overseas Bank. 29) Bank of India. 30) Indian Bank. 31) Indian Overseas Bank. 32) Oriental Bank of Commerce. 33) Central Bank of India. 34) State Bank of Patiala. 35) Punjab & Sind Bank. 36) State Bank of Bikner & Jaipur

A. CONTRACT EXECUTION BANK GUARANTEE (CEBG)

This deed of guarantee made this day of 200.. by the in favour of **Bharat Heavy Electricals Limited, Tiruchirappalli** having its registered Office at New Delhi with its Unit Office at Tiruchirappalli (Hereafter called the first party) where as M/s..... having its registered office at (hereafter called the contractor) have entered in to contract with the first party for the supply of vide Letter of Intent No dated

And whereas the contractor M/s have approached the for a guarantee and at their request and in consideration of the arrangement arrived at between the contractor and the BHEL Tiruchirappalli the said has agreed to give such guarantee as herein after mentioned to the aforesaid first party.

Now therefore, these present witness that we the do hereby undertake to the first party a sum of Rs (Rupees only) without demur/on demand being made by the said first party and to keep the first party indemnified to the extent of Rs (Rupees only) by virtue of this guarantee against any breach in execution of contract without giving prior information to the party of the same (the decision in this respect being solely the discretion of the first party). We further undertake to pay the aforesaid amount in the lump sum on demand without demur or such part thereof as the first party may demand from time to time, irrespective of the fact whether the said contractor admits or denies such claim or questions its correctness in any court tribunal of arbitration proceedings or before any authority.

The aforesaid guarantee will remain in full force and we shall be liable under the same irrespective of any concession for time being granted by the said first party to contractor M/s in or for fulfilling the said agreement between the contractor M/s and the first party and the guarantee will remain in full force till irrespective of any change of terms, conditions or stipulation or any variations in the terms of said agreement irrespective of whether notice of such change or variation is given to us or not and claim to receive such notice of any change and/or variation of the terms and/or conditions of the said agreement is hereby specifically waived by us.

Further we shall not be released from this guarantee by any forbearance or the exercise or non exercise of any of the power or rights under the said agreement by the said first party against the contractor irrespective of whether notice of such forbearance enforcement or non-enforcement of any power or rights, modifications or changes made in the said agreement or concessions shown to contractor M/s by the first party is given to us or not.

The guarantee herein contained shall not be determined or affected by the liquidation of winding up or insolvency of or change in the constitution of the contractor M./s but shall in all respects and for all purposes binding and operative until all payments of all moneys dues or that may hereafter becomes due to the said first party is paid in respect of any liability or obligation for the contractor under this guarantee subject to however that the first party shall have no right under this guarantee after expiry of six months from the date of completion of the contract unless this guarantee is extended by mutual agreement.

And lastly we undertake not to revoke this guarantee during its currency except with the previous consent of the first party in writing. The hereby declares that it has power to issue this guarantee under the Company's memorandum and article of association and the undersigned has full power to do so on its behalf under the power of attorney dated granted to him by the proper authorities of the Company.

Notwithstanding anything contained here in before, our liability under this guarantee is restricted to Rs (Rupees only). Our guarantee shall remain in force till unless a claim in writing is presented to us and if unpaid a suit or action to enforce such claim is filed against within 6 months from the date, all your rights under this guarantee shall be forfeited and we shall be released and discharged from all liability there under.

Dated the by its constituted attorney.

B. PERFORMANCE BANK GUARANTEE (PBG)

1. In accordance of M/s Bharat Heavy Electricals Limited (A Government of India undertaking, a Company incorporated under the Companies Act 1956 having its Registered Office at 'BHEL House", SIRI Fort, New Delhi 110 049) through its High Pressure Boiler Plant Division located at Tiruverumbur, Tiruchirappalli 620014 (hereinafter called "the Company") having entered into a contract with hereinafter called "the said contractor" which term includes 'suppliers' for the purpose of this Bond and under the terms and conditions of the Contract No: dated between BHEL, Tiruchirappalli and as per the contract, the contractor/supplier is to furnish a Performance Bank Guarantee for Rs for the due performance of the equipment to be supplied under the above referred contract and for the fulfilment of all the terms and conditions of the contract. We (indicate the name of the Bank) (herein after referred to as the Bank) at the request of (contractor(s)) do hereby undertake to pay the Company an amount not exceeding Rs against any loss or damage caused to or suffered or would be

caused to or suffered by the Company by reason of any breach by the said contractor (s) of any of the terms and conditions contained in the said agreement.

2. We (indicate the name of the Bank with full address), do hereby undertake to pay the amounts due and payable under this guarantee without any demur, merely on a demand from the Company stating that the amount claimed is due by way of loss or damage caused to or would be caused to or suffered by the Company by reason of breach by the said Contractor(s) of any of the terms and conditions contained in the said Agreement or by the reason of the contractor(s) 'failure to perform' the said Agreement. Any such demand made on the Bank shall be conclusive as regards the amount due and payable by the Bank under this guarantee. However, our liability under this guarantee shall be restricted to an amount not exceeding Rs
3. We undertake to pay unconditionally to the Company any money so demanded notwithstanding any dispute(s) raised by the Contractor in any suit, or proceedings pending before any Court or Tribunal or Arbitration or before any other authority relating thereto our liability under this present being absolute and unequivocal. The payment under this guarantee would not wait till the disputes have been decided by any Court or Tribunal or in the arbitration proceedings or by any other authority. The payment so made by us under this Bond shall be a valid discharge of liability for payment there under and the Contractor (s) shall have no claim against us for making such payment.
4. We (indicate the name of Bank), further agree that the guarantee herein contained shall remain in full force and effect during the period that would betaken for the performance of the said Agreement and that it shall continue to be enforceable till all the dues of the Company under or by virtue of the said Agreement have been fully paid and its claim satisfied or discharged or till Office/Department/Division of the Company certifies that the terms and conditions of the said Agreement have been fully and properly carried out by the said Contractor(s) and accordingly discharges this guarantee.
5. (i) Unless a demand or claim under this guarantee is made on us in writing on or before the we shall be discharged from all the liability under this guarantee thereafter. But where such claim or demand has been preferred by the Company with the Bank before the expiry of the said date, the claim shall be enforceable notwithstanding the fact that the said enforcement is effected after the said date.

(ii) For the purpose of this clause, any letter making demand on the Bank by M/s BHEL will be dispatched by Registered Post with Ack. Due or by Telegram or by any Electronic media addressed to the above mentioned address of the Bank shall be deemed to be the claim/demand in writing referred to above irrespective of the fact as to whether and when the said letter reaches the Bank, as also any letter containing the said demand or claim is lodged with the Bank personally.
6. We (indicate the name of the Bank), further agree with the Company that the Company shall have the fullest liberty without our consent and without affecting in any manner our obligations hereunder to vary any of the terms and conditions of the said agreement or to extend time of performance by the said Contractor(s) from time to time or to postpone for any time of from time to time any of the powers exercisable by the Company against the said Contractor (s) and to forbear or enforce any of the terms and conditions relating to the said Agreement

and we shall not be relieved from our liability by any reason of any such variation or extension being granted to the said contractor(s) or for any forbearance, act or omission on the part of the Company or any indulgence by the Company to the said Contractor(s) or by any such matter or thing whatsoever which under the law relating would, but for this provision, have effect of not so relieving us.

7. This guarantee will not be discharged due to the change in the constitution of the Bank or the Contractor(s)
8. It shall not be necessary for the Company to proceed against the contractor before proceeding against the guarantor–Bank and the guarantee herein contained shall be enforceable against them notwithstanding any security, which the Company may have obtained or obtain from the Contractor shall, at the time when proceedings are taken against the guarantor hereunder be outstanding or unrealised.
9. Any claim or dispute arising under the terms of this document shall only be enforced or settled in the Courts at Tiruchirappalli.
10. The guarantor hereby declare that it has power to execute this guarantee and the executant has full powers to do so on its behalf under the proper authority granted to him/them by the guarantor
11. We (indicate the name of Bank) lastly undertake not to revoke this guarantee during its currency except with the previous consent of the Company in writing.

In witness whereof we (indicate the name of Bank) have hereunto set out Bank Seal the Day month 2012.

ACCEPTANCE OF COMMERCIAL TERMS AND CONDITIONS BY THE BIDDERS

SI No.	Description	Vendor's confirmation
1	<p>Payment terms: 80% of the material cost Plus 100% taxes & duties shall be paid against delivery within 45 days subject to certification by user dept. Balance 20% of the material cost along with Erection & Commissioning charges, if any, will be paid after successful commissioning & acceptance of equipment at BHEL, Tiruchy, against submission of Performance Bank Guarantee for 10% value of the contract.</p> <p>In case of import, 80% Payment of the Po Value through Usance LC, on prorata supplies, which will be established one and half months prior to delivery date and the payment will be effected on 45th day from the date of Bill Of Lading and the balance 20% payment of the PO value through Usance LC to be opened one month prior to start commissioning.</p> <p>Payment will be effected on 45th day against commissioning report / acceptance of the equipment against submission of 10% Performance bank guarantee encashable in India, form BHEL consortium of bankers or any nationalised bank in India.</p> <p>All LC opening charges in India and outside India will be to the supplier's account.</p> <p>Loading for deviation on payment terms if the above is not agreed by vendor will be @ 1.5% per month.</p> <p>Note: In case any bidder does not accept for payment of 20% payment after successful commissioning & acceptance of equipment at BHEL, Tiruchy and submission of Performance Bank Guarantee for 10%, their offer is likely to be rejected and the technical bid not processed.</p>	
2	TERMS OF DELIVERY	FREE DELIVERY AT SSTP/Stores(preferred)



3	<p>Currency of payment: In case of foreign bidders please indicate the currency like Euro / US\$ / GBP etc. For indigenous bidders the currency shall be Indian Rupees</p>	
4	<p>Taxes & Duties: All Taxes, Duties, Service Taxes etc. payable as extra to the quoted price should be specifically stated in offers along with CST & TIN No / Tariff No. etc., failing which the purchaser will not be liable for payment of such Taxes and Duties. Our TIN No. 33243560005, TNGST No. 3560005, CST. No. 239383 Dt. 11-06-1991 & BHEL ECC No. AAACB4146PXM012, Assessment circle Tiruverambur</p> <p>Income Tax applicable. Any service charges payable towards supervision of E&C, training, performance prove-out etc., will be released after deduction of Income Tax as per Indian Income Tax Act / as per the Govt. of India rules. The TDS certificate will be issued by BHEL.</p>	
5	<p>Contract Execution Bank Guarantee: The successful bidder shall furnish a Contract Execution Bank Guarantee (CEBG) equal to 5% in the format enclosed and from one of the banks mentioned therein. In case of import, the foreign vendor shall arrange to give a counter guarantee to State Bank of India (SBI), Kailasapuram and SBI will provide the CEBG to BHEL in the format enclosed. The CEBG shall be executed valid for the delivery period (FOR dispatching station for indigenous / FOB delivery for import) with additional 2 months as claim period. The CEBG shall be furnished within 1 month from the date of Letter of Intent. In case any bidder does not accept for submission of Contract Execution Bank Guarantee (CEBG), their offer is likely to be rejected and the technical bid not processed.</p>	
6	<p>Performance Bank Guarantee: Performance Bank Guarantee (PBG) for 10% of the total order value covering the agreed Guarantee period (with additional 2 months as claim period) has to be furnished. In case of indigenous bidder</p>	

	<p>the PBG shall be in the format enclosed and from one of the banks mentioned therein. In case of import, the foreign vendor shall arrange to give a counter guarantee to State Bank of India (SBI), Kailasapuram and SBI will provide the PBG to BHEL in the format enclosed.</p> <p>In case any bidder does not accept for submission of Performance Bank Guarantee (PBG), their offer is likely to be rejected and the technical bid not processed.</p>	
7	<p>Liquidated damages: Delivery of the goods specified in the purchase order should be made within the time prescribed. Failure to dispatch the materials in the time as per the delivery quoted in our Purchase Order would make the supplier liable to an un-conditional penalty at the rate of ½% of the value of delayed goods for each week of delay subject to a maximum of 15% of the Purchase Order value. If any vendor does not accept LD ½% of the value of goods for each week of delay subject to a maximum of 5%, their offer is likely to be rejected by BHEL and the technical bid not processed. Bidders accepting for maximum LD percentages in between 5% to 15% will be loaded @ %age deviation from 15% and their accepted %age. Eg. If a bidder accepts for a max of 7% LD, their offer would be loaded @ 3% (15 – 7 = 8). As regards LD, the delivery date (FOR dispatching station for indigenous / FOB delivery for import) shall be considered.</p>	
8	<p>Risk purchase: If the supplier fails to deliver the goods within the delivery specified in the Purchase Order, BHEL will be entitled to terminate the contract and to purchase elsewhere at the risk and cost of the seller either the whole of the goods or any part which the supplier has failed to deliver or despatch within the delivery period mentioned in the Purchase Order.</p>	
9	<p>Delivery: DELIVERY REQD BY BHEL/SSTP is (10 Months) Bidder shall indicate the delivery period required for the following activities. (a) Firm Time period, from the date of Letter of Intent (Lol), required for delivery of the equipment, (FOR dispatching station for indigenous / FOB delivery for import) to be indicated. (b) Commissioning, Prove-out and handing over of complete system to be indicated. Note: The above delivery periods indicated will not</p>	

	have bearing on activities such as submission of CEBG, drawing approval etc. It shall be the bidder's responsibility to have all technical clarifications sorted out before submission of price bid / participating in the RA. The Purchase Order (to be release after receipt of CEBG) will carry the above-indicated delivery period.	
9	Agency Commission: Please specify the %age agency commissioning, if applicable or else please mention "not-applicable"	
10	Validity: Validity of the offer should be 180 days from the date of tender opening.	
11	Contacts: Details of contact person's name, designation, department with complete postal and email address along with phone and fax numbers to be mentioned	
12	Port of loading:	
13	Country of origin:	
14	Weight: Approximate Net weight of the total consignment Approximate Gross weight of the total consignment	

Date:

Signature:

Name:

Designation:

Department:

M/s