

CNC VTL : TABLE DIA - 2500 MM

PART- A		
CNC VERTICAL TURNING LATHE - TABLE Φ 2500mm		
SECTION - I : QUALIFYING CRITERIA		
The BIDDER has to compulsorily meet the following requirements to get qualified for considering the technical offer for the CNC VERTICAL TURNING LATHE-TABLE Φ2500 mm		
SL NO	REQUIREMENTS	VENDOR'S RESPONSE
1.0	Only those vendors (OEMs), who have supplied and commissioned at least one CNC VERTICAL BORING MACHINE of same (Table diameter 2500mm, Load Capacity 40 tons, Hydro-static guideways & Max Turning Height 2500mm) or higher sizes for similar applications in the past ten years (on the date of opening of Tender) and referred machine is presently working satisfactorily for more than one year (on the date of opening of Tender) after commissioning, should quote. However, if referred machine (s) has/had been supplied to BHEL, then the machine should be presently working satisfactorily for more than six months (on the date of opening of Tender) after its commissioning and acceptance in BHEL. The following information should be submitted by the vendor about the companies where referred machines have been supplied.	
The vendor should submit following information where similar machine has been supplied for qualification of their offer.		
1.1	Name and postal address of the customer or company where similar machine is installed.	
1.2	Name and designation of the contact person of the customer.	
1.3	Phone, FAX no and email address of the contact person of the customer	
1.4	Month and Year of commissioning of the machine.	
1.5	Application for which the machine is supplied.	
1.6	Performance certificate from the customers regarding satisfactory performance of machine supplied to them (Original Certificate or Through e-mail directly from the customer. Refer Clause 10.0 below).	
1.7	BHEL reserves the right to verify the information provided by vendor. In case the information provided by vendor is found to be false/ incorrect, the offer shall be rejected.	
SECTION- II		
The BIDDER / VENDOR is requested to provide the following information:		
SL NO	REQUIREMENTS	VENDOR'S RESPONSE
2.0	The BIDDER / VENDOR to furnish Reference List of Customers, with full address, details of contact person, where similar CNC VERTICAL TURNING LATHES have been supplied in the past.	
3.0	Specify details of CNC VERTICAL TURNING LATHES supplied to other units of BHEL,if any. (Year of commissioning, Table size, Table Load Capacity, Max Turning Height etc.)	

CNC VTL : TABLE DIA - 2500 MM

SL NO	REQUIREMENTS	VENDOR'S RESPONSE
4.0	Details on SERVICE-AFTER-SALES Set-up in India Including the Address of Agents / Service Centers in South India.	
5.0	Any Additional data to supplement the manufacturing capability of the BIDDER for the subject equipment.	
SECTION-III		
The BIDDER to note:		
SL NO	REQUIREMENTS	VENDOR'S RESPONSE
6.0	The BIDDER / VENDOR shall submit the offer in TWO PARTS. 1. Technical Offer [with PART A & PART B] 2. Commercial Offer.	
7.0	The Technical Offer shall contain a comparative statement of Technical Specifications demanded by BHEL and Offer Details submitted by the Bidder , against each clause.	
8.0	The Technical Offer shall be supported by product Catalogues & Data Sheets and also technical details of Bought- Out- Items with copies of Product Catalogue to the extent possible.	
9.0	The Commercial Offer (given with the Technical Offer) shall contain the Scope of Supply and the Un-Priced Part of the Price-Bid, for confirmation.	
10.0	For obtaining the performance certificate from the customer, a suggestive format is provided in SECTION-IV	
SECTION -IV		
The Performance certificate should be produced on Customer's Letter Head .		
PERFORMANCE CERTIFICATE		
1	Supplier of the Machine	
2	Make & Model of the Machine	
3	Month & Year of Commissioning	
4	Application for which M/C is used	
5	Machine Details:	
5.1	Table size	
5.2	Weight carrying capacity	
5.3	Maximum Turning Height	
5.4	Hydro-static guideways (Yes/No)	
5.5	CNC system	
6	Performance of the Machine (Satisfactory/ Un-satisfactory)	
7	Any Other remarks	
	Date:	Signature & Seal of the Authority Issuing the performance Certificate

PART - B : TECHNICAL SPECIFICATION

Heavy Power Equipment Plant
Bharat Heavy Electricals Limited,
 Ramachandrapuram - 502032, Andhra Pradesh, INDIA.

Enquiry No. & Dt.:

Due Date :

Supplier's Ref.:

Date :

Specification cum Compliance Certificate for CNC VERTICAL TURNING LATHE (φ2500 mm)**Note:-**

1. The Column " VENDOR'S OFFER WITH TECHNICAL DETAILS & REMARKS" of this format shall be filled in by the Vendor and submitted along with the offer. Inadequate / incomplete, ambiguous or unsustainable information against any of the clauses of the specifications / requirements shall be treated as non-compliance.

2. The offer and all documents enclosed with offer should be in English language only.

Name & Address of the Supplier:

Name & Address of the Indian Agent:

Telephone No.

Telephone No.

Fax No.

Fax No.

e-mail :

e-mail :

Scope: Supply, Erection & Commissioning of **CNC VERTICAL TURNING LATHE (φ2500 mm)** complying with specification as below.

SL. NO.	BHEL TECHNICAL SPECIFICATION	VENDOR'S OFFER WITH TECHNICAL DETAILS & REMARKS
1	PURPOSE & WORKPIECE MATERIAL	
1.1	PURPOSE/APPLICATION: This machine is required to rough & finish machine components for Power Generation Industry demanding high accuracies & surface finish.	Vendor to note & accept
1.2	WORK PIECE MATERIAL : Forgings / castings of Alloy steels, Stainless Steel, Inconel, cast iron and similar other materials which are generally used in power producing equipments having hardness 150 to 400 BHN.	Vendor to note & accept
2	SPECIFICATION:	
2.1	MACHINE CONFIGURATION	
2.1.1	Single/Double Column CNC Vertical Borer with Single Ram. Cross rail to be guided on two guideways at each end i.e., four guideways total.	Vendor to offer
2.2	CAPACITY & SIZE	
2.2.1	Maximum Height for Turning & Facing	2500mm or more
2.2.2	Maximum Turning Diameter	2800mm or more
2.2.3	Maximum Workpiece Weight	40000Kg or more
2.2.4	Maximum Swing Diameter	2800mm or more
2.2.5	Minimum Boring Diameter (using standard turning tool holder & tool clamped on the ram)	Vendor to inform
2.3	TABLE	

SL. NO.	BHEL TECHNICAL SPECIFICATION	VENDOR'S OFFER WITH TECHNICAL DETAILS & REMARKS
2.3.1	Table Diameter	2500mm
2.3.2	Load Capacity	40000Kg or more
2.3.3	Table Speed (Infinitely Variable)	0.5 or less to 150rpm or more
2.3.3.1	No. of Speed Ranges	Vendor to inform
2.3.4	Power of Main motor (S1 - Continuous Rating) AC	60KW or more
2.3.5	Details of Main motor viz.Type, Make, Model etc.	Vendor to inform
2.3.6	No. of Jaws/Vices	4
2.3.6.1	Additional No. of Jaws/Vices as spares	4
2.3.7	Maximum External Clamping Diameter	Vendor to inform
2.3.8	Minimum External Clamping Diameter	Vendor to inform
2.3.9	Maximum Internal Clamping Diameter	Vendor to inform
2.3.10	Minimum Internal Clamping Diameter	Vendor to inform
2.3.11	Clamping Force of each Jaw.	Vendor to inform
2.3.12	Positions and Dimensions of the Jaws on Table. Chucking Capacity Diagram should be submitted.	Vendor to inform & submit
2.3.13	Type of Force Multiplier Mechanism used in Jaws should be explained and Drawings should be submitted.	Vendor to inform & submit
2.3.14	Maximum permissible Cutting Force	Vendor to inform
2.3.15	Maximum permissible Torque	Vendor to inform
2.3.16	RPM at which Max. Torque is available.	Vendor to inform
2.3.17	Table Torque - Speed diagram should be submitted.	Vendor to submit
2.3.18	Type of Bearing for the Table (Details to be submitted)	Vendor to inform
2.3.19	Size of T - slots, their position and accuracy. Drawing of Table showing details of the T - slots etc. should be submitted.	Vendor to submit
2.3.20	Two perpendicular accurate Slots should be provided at the Center of the table to use for alignment purposes. Sizes (Width & Depth), accuracy etc. of these slots should be furnished along with a Drawing.	Vendor to inform & submit
2.3.21	Table Loading Diagram should be submitted (Load v / s Distance from Table Center) for uniform as well as for eccentric loading.	Vendor to submit
2.3.22	Diameter, Depth and Accuracy of Center Bore on Table Top Surface.	Vendor to inform
2.3.23	Single piece construction of machine table	Vendor to confirm
2.4	CROSS RAIL	
2.4.1	Vertical Travel.	Vendor to inform
2.4.2	Vertical Traverse Rate.	Vendor to inform
2.4.3	No. of Positions.	Vendor to inform
2.4.4	Distance between each Position/Step	Vendor to inform
2.4.5	Distance of lowest Step from Table Top	Vendor to inform
2.4.6	Distance of highest Step from Table Top	Vendor to inform
2.4.7	Maximum Height of Cross Rail bottom from Table Top	Vendor to inform
2.4.8	Minimum Height of Cross Rail bottom from Table Top	Vendor to inform

SL. NO.	BHEL TECHNICAL SPECIFICATION	VENDOR'S OFFER WITH TECHNICAL DETAILS & REMARKS
2.4.9	Movement of Cross Rail : Through NC Program as well as manually by Push Buttons	Vendor to offer
2.4.10	Machine Reference Point should be at Ram Reference Point and it should be updated automatically with movement of Cross Rail	Vendor to offer
2.4.11	Details of crossrail movement/positioning/locking mechanism	Vendor to submit
2.5	TOOL HEAD and RAM	
2.5.1	No. of Columns	1 or 2
2.5.2	No. of Rams	1
2.5.3	Cross - Section of Ram (It should be rigid enough for troublefree machining with maximum projection of ram)	Vendor to inform
2.5.4	Thread Cutting Capacity - maximum Pitch	Vendor to inform
2.5.5	Clamping details for mounting Turning Tool Holders/Attachments on ram, should be submitted.	Vendor to submit
2.5.6	Mounting of Turning Tool Holders and Attachments should be automatic through Program as well as manually through push buttons.	Vendor to confirm
2.6	MAIN TRAVERSES	
2.6.1	Vertical Travel of Ram (Z-Axis) For maximum turning/facing height of 2500mm. (If offered Turning Height, Sl.No.. 2.2.1, is more than 2500mm, Ram travel should also be increased by half value of increase in Turning Height above 2500mm)	1250mm or more
2.6.2	Horizontal Travel of Ram (+ve X-Axis)	Vendor to inform
2.6.3	Horizontal Travel of Ram beyond Center of the Table (-ve X-Axis)	300mm or more
2.6.4	Maximum Distance between Table Top and Standard Turning Tool Holder with Tool.	Vendor to inform
2.6.5	Minimum Distance between Table Top and Standard Turning Tool Holder with Tool.	Vendor to inform
2.7	MACHINE GUIDEWAYS	
2.7.1	Width of Cross Rail guideways	Vendor to inform
2.7.2	Width of column guideways	Vendor to inform
2.7.3	X & Z guide ways should be hydrostatic (Details should be submitted)	Vendor to confirm
2.7.31	Rotary guide ways for the table should be hydrostatic, details along with min. and max. dia of Hydrostatic bearing should be submitted.	Vendor to confirm
2.7.4	Hardness of guideways	Vendor to inform
2.7.5	Metallic Telescopic Covers: Waterproof Telescopic Covers of rust resistant steel should be provided with pads/wipers on both left and right sides of tool head on the crossrail and also above & below the crossrail on both columns covering the guide ways. Joints of telescopic covers should be sealed to avoid mixing of coolant & hydrostatic oil . The movement of telescopic covers should be troublefree and requiring minimum maintenance.	Vendor to offer
2.8	FEEDS AND DRIVE SYSTEM	
2.8.1	Cutting feed in X & Z Axes (Infinitely Variable)	0 - 5000mm/min or more
2.8.2	Rapid feed in X & Z Axes	5000mm/min or more

SL. NO.	BHEL TECHNICAL SPECIFICATION		VENDOR'S OFFER WITH TECHNICAL DETAILS & REMARKS
2.8.3	Feed drives/motors X & Z axes [AC servo motors] of Siemens/Fanuc digital type (details of model, make, type, rating etc. should be submitted)	Vendor to offer	
2.8.4	Maximum cutting force permissible on Ram & at what extension	Vendor to inform	
2.8.5	Maximum permissible Cutting Force at Maximum Ram extension	Vendor to inform	
2.8.6	Permissible Cutting Force v / s Ram Projection - Diagram should be submitted.	Vendor to submit	
2.8.7	Feed back system for X & Z axes should be Heidenhain linear scales with pressurized compressed air cleaning. (Details should be submitted) The Air supply system shall have suitable drier, if required.	Vendor to offer	
2.8.8	Details of backlash free movement mechanism in X & Z axes should be submitted.	Vendor to submit	
2.8.9	Mechanism for locking X & Z axis	Vendor to inform	
2.9	CONSTRUCTION		
2.9.1	Vendor to furnish details of material, hardness & constructional details, including explanatory drawings, of various components/ assemblies like Column, Cross Rail, Ram head, Table, Guideways/slides, Feed Transmission system, Ram, Hydraulic and Lubrication system, Feedback system etc .of the machine.	Vendor to submit	
2.9.2	Video images on CD including hard copy explaining the technical features / Literature with photographs, drawings explaining the technical features should be enclosed with the offer.	Vendor to submit	
2.10	OPERATION AND CONTROL SYSTEM		
2.10.1	OPERATOR'S PANEL		
	Swivellable hanging pendant type operator panel having complete CNC and machine control system with all displays of required configuration shall be provided for convenient, efficient & safe operation of the machine. All switches with suitable interlocks with table rotation should be within reach of operator of average Indian height (5' 5") for easy & safe operation. All displays/indications should also be conveniently placed accordingly. A protection cover made of steel sheet or equivalent should be provided above the operator's panel. Layout showing complete details should be submitted.	Vendor to offer	
2.10.2	CNC SYSTEM & FEATURES :	Vendor to note & accept	
2.10.2.1	Make	Siemens or Fanuc	
2.10.2.2	Type	PC based latest version	
2.10.2.3	Model: Latest version & model of CNC system, as available at the time of ordering, should be supplied.	Vendor to offer and submit details	
2.10.2.4	Details of Standard features	Vendor to submit	
2.10.2.5	Details of optional features such as parametric programming, copy & paste of programs and others recommended by vendor for proveout components for specified turning operations or foreseen as required keeping in view of offered accessories/systems/special features etc..	Vendor to submit	

SL. NO.	BHEL TECHNICAL SPECIFICATION		VENDOR'S OFFER WITH TECHNICAL DETAILS & REMARKS
2.10.2.6	The system should have Operator's Panel with TFT color display (15 inch or more), Machine Control Panel , Full CNC Keyboard and Mouse/Trackball, Communication Ports for data transfer, LPT1 Parallel Interface for Printer, VGA, MPI interface & USB, and Expansion slots. The CNC System shall also have Electronic hand wheels selectable for all axes, USB Port with 2 GB Pen drive for data input/output, Hard disk of 10 GB or higher, Graphic Simulation, COM port for telediagnosics, Network ready with LAN and preinstalled system software & other required softwares etc. (Details should be submitted by Vendor)	Vendor to offer and submit details	
2.10.2.7	In case of non-availability of COM port, LPT1 interface, etc. (if not provided by CNC system manufacturer at the time of supply), suitable separate ports for networking with LAN, data input/output, telediagnosics, printer shall be provided. In case only USB ports are provided, suitable hardware/connectors shall be provided to ensure above functionalities.		
2.10.2.8	Fast & user-friendly Graphic Simulation for checking of program prior to actual running & Block-Search with calculation while running the program should be pre-installed in the CNC system in addition to all other required/recommended features.	Vendor to offer	
2.10.2.9	Additionally, a QWERTY keyboard and optical mouse (or equivalent in case of Fanuc) should also be properly interfaced and suitably inhouse in the system's panel on covered sliding type tray for editing/input of programs by programmer.	Vendor to offer	
2.10.2.10	Provision of On-screen PLC logic display on the CNC System for diagnostic purposes.	Vendor to offer	
2.10.2.11	In-cycle hour counter with reset facility shall be provided.	Vendor to offer	
2.10.2.12	Power meter for indicating total energy consumption of the machine shall be provided.	Vendor to offer	
2.10.3	HAND HELD UNIT:		
2.10.3.1	Hand Held unit with jog axes, spindle inching, hand-wheel and sufficient length of interfacing cable, which can be taken near to the chuck for job setting and similar other purposes.	Vendor to offer	
2.10.4	MANUAL CONTROL		
2.10.4.1	Complete manual control of machine with required switches / keys should be provided on operator's panel for selection of required axis, axis direction, cutting feed, table rpm, cutting feed on/off, display of axis position values etc, for manual machining operations without using CNC program / MDI mode. Diagram / Sketches for switches / keys provided on operators pendant should be submitted.	Vendor to confirm. Layout of panel showing requisite switches to be submitted.	
2.10.5	DIAGNOSTIC SYSTEMS		

SL. NO.	BHEL TECHNICAL SPECIFICATION		VENDOR'S OFFER WITH TECHNICAL DETAILS & REMARKS
2.10.5.1	FAULT DIAGNOSTIC SYSTEM: Supplier's own diagnostic system with required Software and Hardware installed on the CNC system, which shows detailed cause and remedy for the fault on the CNC system. Vendor should also offer a PC NOTE BOOK along with PLC software (licensed copy), necessary cables, required hardwares/Adaptors (for Communication with the CNC/PLC system). The Note Book PC should be loaded with complete Electrical Schemes, Mechanical Assembly drawings, Hydraulic Circuit Diagrams, Operation and Maintenance Manuals, Machine Alarm list along with Help text wiring diagram, On-Line display of PLC user logic should be available on the note book PC. Procedure of fault-diagnostic system and data transfer/PLC logic transfer between PC Notebook & CNC/PLC system should be demonstrated to BHEL during commissioning of the machine.	Vendor to offer & submit	
2.10.5.2	Separate Hand Held Pendant/suitable arrangement should be provided with individual steps to retrieve the ATC to it's initial position in case of interruption of ATC's positioning cycle due to alarm on the machine or power failure .	Vendor to offer	
2.10.5.3	Machine should have provision to switchover from direct position feedback system (linear scale/encoder) to indirect position feed back system (motor encoder) and vice-versa. (for troubleshooting & maintenance purposes)	Vendor to offer	
2.10.5.4	Help guide should be provided to use both diagnostic systems	Vendor to offer & submit	
2.10.6	NETWORKING		
2.10.6.1	Machine control should have necessary hardware and software for interfacing with Ethernet Local Area Network for NC program and other related data transfer. This network to be connected to wide area network/Internet/BHEL intranet. The networking should have following capabilities:	Vendor to offer	
2.10.6.2	The machine shall appear as a node in the Entire Network. (Network Neighbourhood)	Vendor to offer	
2.10.6.3	The program transfer shall be by simple copy and paste method provided sharing access is allowed between any PC and the machine across the network.	Vendor to offer	
2.10.6.4	The program transfer between CNC system and network should also be possible in CNC Mode.	Vendor to offer	
2.10.7	MACHINE MONITORING SYSTEM (MMS) SIGNALS		
2.10.7.1	Following MMS signals would be made available on a specifically earmarked terminal strip. These MMS signals would be sourced from CNC system/PLC output card separately.	Vendor to offer	
2.10.7.2	Control ON	Vendor to offer	
2.10.7.3	Cycle ON	Vendor to offer	
2.10.7.4	Spindle Running	Vendor to offer	
2.10.7.5	Feed Active (Any of the axes moving)	Vendor to offer	
2.10.7.6	M30 (Program Stop)	Vendor to offer	
2.11	UPS FOR CNC SYSTEM :		

SL. NO.	BHEL TECHNICAL SPECIFICATION	VENDOR'S OFFER WITH TECHNICAL DETAILS & REMARKS
2.11.1	UPS of 30 minutes for CNC system with in-built cooling and charge status display (Battery charging /discharging time should be specified by vendor)	Vendor to offer
2.12	MACHINE LIGHTS	
2.12.1	Machine Lights for sufficient illumination of complete working area including operator's panel should be provided for clear visibility.	Vendor to offer
2.12.2	A magnetic base portable spot light with sufficiently long cable should also be provided.	Vendor to offer
2.12.3	Any lights required in the foundation/ pit area shall also be foreseen and supplied by the vendor.	Vendor to offer
2.12.4	All light fittings, consumables, adapters/receptacles should have compatibility with Indian equivalents	Vendor to offer
2.12.5	Flashing/Rotary type light indicating end of cutting, program stop, alarm etc. at a easily visible & suitable place.	Vendor to offer
2.13	AIR CONDITIONERS	
2.13.1	Independent air conditioners with Dehumidifiers of suitable & sufficient capacity to be provided for each Electrical / Electronic Panels / Cabinets including Operator's Panel considering specified ambient conditions. Detailed specifications of the same are to be submitted.	Vendor to offer
2.13.2	In case of order vendor shall provide following information about Air Conditioners and Chiller Unit (s) used in the machine: Type of Refrigeration/ Chiller unit. The Capacity of the chiller unit. Type of compressor with complete specifications. Type of Thermostatic Expansion Valve with complete specifications. Fan size and flow in CFM (cubic feet meter) of the Condenser unit. Specifications of the Evaporator Unit (Width Plate type/ Coil type) Functional requirement of temperature of Cooling Oil to be maintained between range T1 to T2. Type of temperature indicator/ controller used in the chiller unit with complete specifications.	Vendor to confirm
2.14	HYDRAULIC SYSTEM (DETAILS TO BE SUBMITTED BY THE VENDOR) :	
2.14.1	The Hydraulic System shall be of Re-circulating Type. Hydraulic Tank should be preferably placed at shop floor.	Vendor to offer and confirm
2.14.2	Pumps, Valves, Switches (Pressure & Flow) should be of Make : Rexroth / Vickers / Parker / Hawe.	Vendor to offer and confirm
2.14.3	Filtration System: Sufficient no. of filters (with electric clogging indicator and alarm on PLC) should be used to avoid frequent clogging of the filters and other maintenance related problems. Filter elements should, preferably, be of Make : EPE / Hydac	Vendor to offer and confirm
2.14.4	Failure indication	Vendor to offer
2.14.5	Automatic shut off provision, Details should be submitted.	Vendor to offer

SL. NO.	BHEL TECHNICAL SPECIFICATION		VENDOR'S OFFER WITH TECHNICAL DETAILS & REMARKS
2.14.6	Refrigerated type cooling and electric heating (Electric heating, only if required) system of sufficient capacity to maintain complete Hydraulic System, including lubrication oil, hydrostatic oil and gearbox oil, etc. keeping in view the specified ambient conditions to be offered with complete details. The temperature of Hydraulic Oil should not go beyond 40 deg. C.	Vendor to offer & submit	
2.14.7	Hydraulic pump capacity (flow / pressure)	Vendor to inform	
2.14.8	No Tandem pumps should be used. Maximum desired permissible pressure is 100 Kg/sqcm. If anywhere, more than 100 Kg/sqcm pressure is used, then one set of such hose pipes and seal kit of such Hydraulic cylinder should be supplied in spare in addition to other spares.	Vendor to confirm & offer	
2.14.9	Complete hydraulic system should be designed to avoid any leakage or spillage.	Vendor to confirm	
2.14.10	Sufficient stages/nos. of filters should be used to avoid frequent clogging of the filters and other maintenance related problems.	Vendor to offer	
2.15	FIRST FILLING OF OILS		
2.15.1	First filling of all required Oils & Grease etc. for the machine, voltage stabilizer, isolation transformer & air-compressor etc. to be supplied by vendor. Indigenous (Indian) source or Indian equivalent and specifications of oils/ greases are also to be provided by the vendor.	Vendor to offer & submit	
2.16	COOLANT SYSTEM		
2.16.1	Re-circulating Type Flood Coolant System with all accessories shall be provided.	Vendor to offer	
2.16.2	All attachments, tool holders, boring bars etc. shall have the provision so that coolant is available directly at the tool-cutting tip.	Vendor to offer	
2.16.3	Coolant collection and recirculation system should be leak proof & perfect to avoid any spillage on shop floor, trenches for cables & foundation pit of the machine etc. In case, any leakage is found, it shall be corrected by vendor. Additionally, suitable equipment should be provided at deepest point of foundation pit to pump out collected oil/coolant up to shop floor.	Vendor to offer & confirm	
2.16.4	Coolant Filtration System: Recirculating type coolant system with Vacuum Rotary drum type Coolant Filtration System and magnetic separator. The filtration system should be mounted at shop floor level, if possible with provision to avoid leakage/spillage of coolant.	Vendor to confirm and submit details.	
2.16.5	Coolant Flow Diagram showing filters, pumps, valves, tanks etc.	Vendor to submit	
2.16.6	Coolant pumps & motor details etc. for all types of coolant variants	Vendor to inform	
2.16.7	Coolant Tank Capacity	Vendor to inform	
2.16.8	Pressure & rate of flow of coolant should be furnished in the offer. The coolant should be able to reach tool tip at full pressure.	Vendor to inform	
2.16.9	The coolant tank should be fitted with skimmer for regular cleaning of coolant from contamination with tramp oil.	Vendor to offer	
2.17	ELECTRICAL :		

SL. NO.	BHEL TECHNICAL SPECIFICATION		VENDOR'S OFFER WITH TECHNICAL DETAILS & REMARKS
2.17.1	415V + 10% / -10%, 50 Hz +/-3 Hz, 3 Phase AC (3 wire system without Neutral) Power Supply will be provided by BHEL at a single point near the machine, as per layout recommended by Vendor. All types of switches, cables, connections, circuit breakers etc. required for connecting BHEL's power supply point to different parts of the machine/control cabinets including Voltage Stabilizer, Isolation Transformer & Air Compressor etc., shall be supplied by the vendor.	Vendor to accept & offer	
2.17.2	Tropicalisation: All electrical / electronic equipment shall be tropicalized.	Vendor to offer	
2.17.3	All electrical & electronic control cabinets & panels should be dust and vermin proof.	Vendor to offer	
2.17.4	All electrical components in the cabinets should be mounted on DIN Rail.	Vendor to offer	
2.17.5	All electrical / electronic panels to be provided with adequate door locks. All electrical & electronic panels including operator's panel should have sufficient illumination and power receptacles/plug points of 220Volts, 5/15 Amp AC with on/off switch. All electrical adapters/receptacles, fittings, consumables etc. should be Indian or should have compatibility with Indian equivalents.	Vendor to offer	
2.17.6	All motors shall conform to IEC or Indian Standards	Vendor to offer	
2.17.7	All cables moving with traversing axes should be installed in Caterpillar/ Drag chain . Additionally, all the cable trays required for laying of cables should be included in the offer.	Vendor to offer	
2.17.8	Vendor should ensure the proper earthing for the machine and its peripherals/accessories. Any material requirement for the same should be informed with foundation design/drawings. The vendor can take earthing connection from the nearest column of the production shop.	Vendor to offer	
2.18	SAFETY ARRANGEMENTS (FOLLOWING SAFETY FEATURES IN ADDITION TO OTHER STANDARD SAFETY FEATURES SHOULD BE PROVIDED ON THE MACHINE):	Vendor to offer	
2.18.1	Machine should have adequate and reliable safety interlocks / devices to avoid damage to the machine, workpiece and the operator due to the malfunctioning or mistakes. Machine functions should be continuously monitored and alarm / warning indications through lights/ alarm number with messages (on CNC display and panels) should be available.	Vendor to offer	
2.18.2	A detailed list of all alarms / indications provided on machine should be submitted by the supplier.	Vendor to submit	
2.18.3	All the pipes, cables etc. on the machine should be well supported and protected. These should not create any hindrance to machine operator's movement for effective use of machine.	Vendor to offer	
2.18.4	All the rotating parts used on machine should be statically & dynamically balanced to avoid undue vibrations & noise.	Vendor to confirm	
2.18.5	Emergency Switches at suitable locations as per International Norms should be provided.	Vendor to offer	

SL. NO.	BHEL TECHNICAL SPECIFICATION	VENDOR'S OFFER WITH TECHNICAL DETAILS & REMARKS
2.18.6	Oil & water pipe lines should not run with electrical cable in the same trench.	Vendor to offer
2.19	ENVIRONMENTAL PERFORMANCE OF THE MACHINE (THE MACHINE SHOULD CONFORM TO THE FOLLOWING FACTORS RELATED TO ENVIRONMENT) :	
2.19.1	Maximum noise level shall be 85 dB(A) at normal load condition, 1 meter away from the machine with correction factor for back ground noise, if necessary. This will be measured as per international standards like DIN 45635-16, if required. Supplier to demonstrate compliance to noise level, if so required.	Vendor to confirm
2.19.2	There shall not be any emissions from the machine except fumes of cutting fluid during machining.	Vendor to confirm
2.19.3	There should not be any effluent from the machine. In case there are any effluents from the machine, requisite effluent treatment plant or pollution control device should be built into the machine by the supplier.	Vendor to confirm
2.19.4	No hazardous chemicals shall be required to be used in the machine.	Vendor to confirm
2.19.5	If any safety / environmental protection enclosure is required it should be built in the machine by the vendor.	Vendor to confirm
2.19.6	Paint of the machine should be oil / coolant resistant and should not get peeled off and mixed up with coolant.	Vendor to confirm
2.21	CHIP CONVEYOR	
2.21.1	An elevating type chip conveyor to carry both short and curly chips efficiently and effectively to the chip bin on shop floor (on left side of the machine) should be provided at appropriate location. Two Chip bins of appropriate size of Indian make, with wheels & handle for movement, should also be supplied. Drg. of chip bin showing its size/shape is to be submitted.	Vendor to offer
2.21.2	Type of chip conveyor	Hinged type or superior
2.21.3	Width of conveyor	Vendor to inform
2.21.4	Elevation of chip conveyor for chip bin	Vendor to inform
2.21.5	Material of chip conveyor (should be rust resistant)	Vendor to inform
2.21.6	Provision for smooth collection of chips from all-around table to the conveyor and for avoiding clogging of chips should be provided. Removable Grill/Mesh type rigid covers should be provided above some portion of the chip conveyor, to enable machine operator's access to chip conveyor from shop floor for disposal of scattered chips on shop floor, if any, through chip conveyor. Details for the same should be submitted by vendor.	Vendor to offer
2.21.7	Operation of chip conveyor (forward, reverse & inch) should be possible through push buttons on operator's panel and also near chips disposal point/chip bin.	Vendor to offer
2.21.8	Layout showing location of chip conveyor should be submitted.	Vendor to submit
2.22	SERVO VOLTAGE STABILIZER	

SL. NO.	BHEL TECHNICAL SPECIFICATION		VENDOR'S OFFER WITH TECHNICAL DETAILS & REMARKS
2.22.1	Indian make Oil / Air Cooled Servo Controlled Voltage Stabilizer suitable for complete machine, its drives, controls, PLC etc. for unbalanced load & supply conditions considering specified power supply & ambient conditions.	Vendor to offer	
2.22.2	Make (Neel or Servomax or Aplab or equivalent reputed Indian Manufacturer)	Vendor to inform	
2.22.3	Model, Rating & Input/Output Voltage etc.	Vendor to inform	
2.22.4	Catalogue of the Voltage Stabiliser shall be submitted with the offer.	Vendor to offer	
2.23	ULTRA ISOLATION TRANSFORMER		
2.23.1	Indian make Ultra Isolation Transformer suitable for complete machine , its drives, controls, PLC etc. for unbalanced load & supply conditions considering specified power supply & ambient conditions.	Vendor to offer	
2.23.2	Make (Neel or Servomax or Aplab or equivalent reputed Indian Manufacturer)	Vendor to inform	
2.23.3	Model, Rating & Input/Output Voltage etc.	Vendor to inform	
2.23.4	Catalogue of the Ultra Isolation Transformer shall be submitted with the offer.	Vendor to offer	
2.24	AIR COMPRESSOR		
2.24.1	Independent Air/Oil cooled, Screw Type Air Compressor (of reputed Indian make Elgi, Chicago Pneumatic or Ingersol Rand) with refrigerated type Dryer & Filter of suitable/sufficient capacity with all required accessories for the total compressed air requirements of the machine & accessories and to suit required air quality should be supplied. The system should be so designed to have additional provision and required accessories so that BHEL compressed air supply (having pressure 5-6 bar with little moisture/dirt content) could be used as and when required. The compressor unit should be suitable for continuous duty considering specified power supply & ambient conditions..	Vendor to offer	
2.24.2	Make, Type & Model	Vendor to inform	
2.24.3	Capacity (Discharge Air Flow & Pressure, Motor Power etc.)	Vendor to inform	
2.24.4	Refrigerant used	Vendor to inform	
2.25	COMPRESSED AIR POINTS		
2.25.1	Suitably located Compressed Air Point near machine table with manually operated ON/OFF Valve and flexible pipe of suitable length for cleaning of workpiece, tools and work area etc.	Vendor to offer	
2.26	CHIP & SPLASH GUARD		
2.26.1	Movable Chip / Splash Guards of sufficient height and made of rust resistant material, should be provided all around the Table(on front side of machine columns) to avoid spilling of Coolant and scattering of Chips on Operator's Panel and Shop Floor. Front part of splash guards should be provided with safety glass for clear visibility, if required.	Vendor to offer	
2.26.2	Additionally a fixed type of splash/ chip guard of atleast full turning height should be provided on rear side of machine i.e. around rear portion of table between columns .	Vendor to offer	

SL. NO.	BHEL TECHNICAL SPECIFICATION		VENDOR'S OFFER WITH TECHNICAL DETAILS & REMARKS
2.26.3	Opening of guards on front side of table should suit maximum possible size of the job which can be loaded on the table. The guards should not provide any hindrance with complete vertical movement of crossrail/ATC on both sides of the table.	Vendor to confirm	
2.26.4	Drawing of Chip/Splash Guards showing total height, layout and other details of the same should be submitted.	Vendor to submit	
2.27	OPERATOR'S PLATFORM		
2.27.1	It should be independent motorized type, movable / adjustable in vertical and horizontal directions. It should be able to reach almost to center of the Table in horizontal direction. Interlocks should be provided for its horizontal / downward movement against rotating Table and against the job (rotating or stationary) to avoid collision / accident. Positions of the gates provided in the platform for Operator's convenience should be informed by the Vendor . Drawing / Details of the Operator's Platform should be submitted. A 15 Amp. Plug Point with ON/ OFF switch is also to be provided on the Platform.	Vendor to offer	
2.27.2	Horizontal movement of complete Platform.	Vendor to inform	
2.27.3	Vertical movement of complete Platform to cover total turning height.	Vendor to inform	
2.27.4	Height of Platform Railing.	Vendor to inform	
2.27.5	Weight Capacity of the Platform.	Vendor to inform	
2.27.6	Minimum Position of Platform from Shop Floor.	Vendor to inform	
2.28	ACCURACIES		
2.28.1	GEOMETRICAL ACCURACIES		
2.28.1.1	Geometrical Accuracy Tests shall be in accordance with relevant & prevailing international standards viz. DIN 8609 / ISO 3655 or equivalent applicable standard. Detailed Test Charts for the same, clearly showing the accuracies to be achieved on the machine, shall also be submitted with the offer.	Vendor to offer	
2.28.1.2	Table Flatness	Vendor to inform	
2.28.1.3	Table Radial Runout	Vendor to inform	
2.28.1.4	Table Axial Runout	Vendor to inform	
2.28.1.5	Cylindricity of turning	Vendor to inform	
2.28.1.6	True roundness of turning	Vendor to inform	
2.28.1.7	Facial run-outs	Vendor to inform	
2.28.1.8	All other accuracies to conform to specified standard (Latest Revision) or Suppliers Test chart whichever is finer and more accurate.	Vendor to inform	
2.28.1.9	All the Geometrical accuracies including test pieces machining for turning operations etc. should be demonstrated to BHEL engineers during pre-acceptance at Suppliers works and again during Erection & Commissioning at BHEL Works. Test pieces are to be supplied by vendor for test pieces machining both at vendor's works & at BHEL's works. Drawings of test pieces to be submitted with the offer.	Vendor to offer, confirm & submit	

SL. NO.	BHEL TECHNICAL SPECIFICATION	VENDOR'S OFFER WITH TECHNICAL DETAILS & REMARKS	
2.28.2	MACHINE POSITIONING & REPEATABILITY ACCURACIES : SHOULD BE MEASURED AS PER VDI/DGQ 3441 (LATEST REVISION) USING LASER INTERFEROMETER.		
2.28.2.1	Positioning accuracy in X axis (Pa) per 1000 mm	0.01mm	
2.28.2.2	Positioning accuracy in Z axis (Pa) per 1000 mm	0.01mm	
2.28.2.3	Repeatability in X axis (Ps)	0.005mm	
2.28.2.4	Repeatability in Z axis (Ps)	0.005mm	
2.28.2.5	Positioning accuracy over entire traverse in X axis (Pa)	Vendor to inform	
2.28.2.6	Positioning accuracy over entire traverse in Z axis (Pa)	Vendor to inform	
2.28.2.7	Total positioning error along X & Z axes per 1000 mm (P)	Vendor to inform	
2.28.2.8	Total positioning error along X & Z axes over entire traverse (P)	Vendor to inform	
2.28.2.9	All the Positioning and Repeatability accuracies should be demonstrated to BHEL engineers during pre-acceptance at Suppliers works and again during Erection & Commissioning at BHEL Works.	Vendor to offer	
3	TOOLING / LEVELLING & ANCHORING SYSTEM		
3.1	STANDARD TOOLING:		
3.1.1	12 Nos of Ram mounted standard Tool Holders for 40x40mm shank with provision for through coolant to be offered.	Vendor to offer	
3.1.2	1 No of each of the following boring bars: 1)φ80x400 2) φ80x600 3)φ100x500 4)φ120x600 5)φ160x800 for Direct Ram mounting with provision for through coolant for 32x32 shank to be offered.	Vendor to offer	
3.1.3	Manufacturing drawings of tool holders & boring bars to be provided along with the offer	Vendor to submit	
3.1.4	Cutting tool holders & inserts as per ANNEXURE-I to be offered for normal operation of the machine	Vendor to offer	
3.1.5	All supplied tool holders, boring bars shall have built in system for the coolant so that coolant is available directly on the cutting tip during all possible operations like deep grooving, turning etc. Provision for external coolant shall also be provided.	Vendor to confirm	
3.1.6	In case of order, manufacturing drgs., catalogues & source of all tooling items should be submitted by vendor.	Vendor to confirm	
3.1.7	Extension blocks of sufficient height to clamp the work piece at a height of 300mm, 500mm & 800mm from table top using 4 nos. of supplied vices/jaws. Manufacturing drawing of the same should be supplied.	Vendor to offer	
3.1.8	8 Nos each of Job mounting parallels of 100, 150 & 200 mm heights shall be offered	Vendor to offer	
3.1.9	8 Nos each of Adjustable work supports & Clamp supports of height range 300 to 500mm, 500 to 800mm and 800 to 1200mm shall be offered.	Vendor to offer	
3.1.10	Tool Storage Cabinets (2 nos.) of reputed Indian make having covered heavy duty drawers of suitable sizes with lock facility to store offered tooling items etc.	Vendor to offer	
3.1.11	1 No of Work bench along with 2 chairs of reputed Indian make	Vendor to offer	
3.1.12	1 No of Godrej Storwel Almira or equivalent	Vendor to offer	

SL. NO.	BHEL TECHNICAL SPECIFICATION	VENDOR'S OFFER WITH TECHNICAL DETAILS & REMARKS	
3.2	TOOLING FOR COMPONENT PROVE-OUT (AS PER CLAUSE 7.0)		
3.2.1	All cutting tool holders, inserts and job holding fixtures etc required for machining of prove out components to be supplied. Supplier should offer all tools & inserts with latest cutting geometries & grades to achieve high productivity and cutting parameters.	Vendor to confirm	
3.2.2	In case of order, manufacturing drgs., catalogues & source of all tooling items should be submitted by vendor.	Vendor to confirm	
3.3	TOOLS FOR ERECTION, OPERATION & MAINTENANCE		
3.3.1	Tools and Equipment required for erection of the machine shall be brought by the vendor. Necessary tools like Torque Wrenches, Set of job clamping accessories (T-nuts, Studs, Clamp supports), Spanners, Keys, grease guns etc. for operation and maintenance of the machine should be supplied by the vendor. List of such tools should be submitted with offer.	Vendor to offer	
3.3.2	Set of Test Mandrels/Cylindrical Bars for checking table run-out & alignment of ram etc. should be supplied with protection boxes.	Vendor to offer	
3.4	LEVELING & ANCHORING SYSTEM		
3.4.1	Complete set of anchoring materials including foundation bolts, nuts, washers, fixators, leveling shoes etc for alignment of table/ram and to fix the machine to the foundation should be supplied. Details to be submitted.	Vendor to offer	
4	ACCESSORIES :		
4.1	AUTOMATIC TOOL CHANGER	Vendor to offer	
4.1.1	Type	Vendor to inform	
4.1.2	No. of storage locations(to suit all the offered tool holders and boring bars)	12 or more	
4.1.3	Tool selection method - Random	Vendor to confirm	
4.1.4	Maximum Permissible Weight on each Pocket.	Vendor to inform	
4.1.5	The Machine operation should be possible with or without referencing ATC.	Vendor to confirm	
4.1.6	ATC Drawing should be submitted with the offer.	Vendor to submit	
4.1.7	Provision for loading/unloading of different holders on ATC using overhead crane, if required.	Vendor to offer	
4.2	GRINDING ATTACHMENT:		
4.2.1	Suitable Grinding Attachment should be offered for Cylindrical (Internal & External both) as well as Face Grinding. Grinding wheel should clear ram in all conditions for cylindrical grinding. It should generate surface finish of 0.8 microns Ra value or better without any chatter or line marks.	Vendor to offer	
4.2.2	Minimum possible internal grinding diameter and depth	Vendor to offer	
4.2.3	The grinding Unit should be supplied with its all required accessories for its' mounting/clamping on the ram, safe and integral power connections with tools for mounting grinding wheel on the unit etc	Vendor to offer and submit	
4.2.4	Balancing device for balancing of grinding wheel before mounting the wheel on grinding unit. Technical details to be submitted.	Vendor to offer	

SL. NO.	BHEL TECHNICAL SPECIFICATION		VENDOR'S OFFER WITH TECHNICAL DETAILS & REMARKS
4.2.5	Programmable grinding cycles, ready for use for CNC controlled grinding & wheel dressing	Vendor to offer	
4.2.6	One set of Grinding wheels for ID/OD & Face Grinding operations	Vendor to offer	
4.2.7	Power	Vendor to inform	
4.2.8	Speed (Infinitely Variable)	Vendor to inform	
4.2.9	Details of the Drive viz. Make, Model etc.	Vendor to inform	
4.2.10	Power - Torque - Speed Diagram	Vendor to submit	
4.2.11	Maximum Diameter of the Wheel	Vendor to inform	
4.2.12	Minimum Diameter of the Wheel	Vendor to inform	
4.2.13	Width of the Wheel	Vendor to inform	
4.2.14	Provision of the Wheel Dressing	Vendor to inform	
4.2.15	Position of the Wheel Dresser. Drawing should be submitted.	Vendor to inform	
4.2.16	Vendor to confirm that sufficient protection for bearings, Guide Ways etc. has been provided.	Vendor to confirm	
4.2.17	Dimensional Details and Weight of Grinding Attachment	Vendor to inform	
4.3	AUTOMATIC TOOL OFFSET MEASURING SYSTEM:		
4.3.1	Automatic Tool Offset measuring system with measuring cycles, calibration system etc suitable for all types of tools recommended for prove-out components. The system shall be capable of measuring tool lengths loading these values into tool offset memory of the machine. The system shall be such that the measurement should be with an accuracy of 10 microns or less. Vendor to furnish detailed description of the system along with offer.	Vendor to submit	
4.3.2	During proveout, all tools shall be set & checked by supplied Automatic tool offset Measuring System using required program supplied by vendor.	Vendor to accept & offer	
4.3.3	Spares Package for the Automatic Tool Offset Measuring system for 2 years trouble free working should also be offered.	Vendor to offer with list.	
4.3.4	Operating Manuals, Maintenance Manuals & Catalogues for offered Automatic Tool Offset Measuring System.	Vendor to offer	
5	SPARES :		
5.1	Itemized breakup of mechanical, hydraulic, electrical and electronic spares used on the machine in sufficient quantity as per recommendation of Vendor for 2 years of trouble free operation on three shifts continuous running basis should be offered by vendor. The list to include following, in addition to other recommended spares: (Unit Price of each item of spare should be offered)	Vendor to offer	
5.1.1	MECHANICAL & HYDRAULIC SPARES: FOLLOWING SPARES ARE TO BE OFFERED		
5.1.1.1	Pressure control valves, Pressure reducing valves, Flow control valves & Direction control valves used in Hyd / Lub / Pneumatic/ coolant circuit. (5 Nos of each type)	Vendor to offer	

SL. NO.	BHEL TECHNICAL SPECIFICATION	VENDOR'S OFFER WITH TECHNICAL DETAILS & REMARKS
5.1.1.2	Pressure switches, flow switches used in Hyd / Lub / Pneumatic/ coolant circuit. (10 No.s of each type)	Vendor to offer
5.1.1.3	All types of regenerative type filter inserts (10 Nos of each type)	Vendor to offer
5.1.1.4	All types of Disposable type filter inserts (30 Nos of each type)	Vendor to offer
5.1.1.5	All types of Accumulators with charging kit (1 no. of each type)	Vendor to offer
5.1.1.6	One set of belts (including timing belt) used in the machine.	Vendor to offer
5.1.1.7	One set of seal kits used in different hydraulic & pneumatic cylinders in the machine.	Vendor to offer
5.1.1.8	All types of shaft seals (2 nos of each type), O-rings & Piston Rings (5 nos of each type) used in the machine.	Vendor to offer
5.1.2	ELECTRICAL/ELECTRONIC/CNC SPARES : FOLLOWING SPARES ARE TO BE OFFERED	Vendor to offer
5.1.2.1	Relays (10 Nos each type)	Vendor to offer
5.1.2.2	Contactors (5 Nos each type)	Vendor to offer
5.1.2.3	Temperature sensing devices (1 No each type)	Vendor to offer
5.1.2.4	Proximity Switches (10 Nos each type)	Vendor to offer
5.1.2.5	Push Buttons (10 Nos each type)	Vendor to offer
5.1.2.6	Indicating Lamps (10 Nos each type)	Vendor to offer
5.1.2.7	Semiconductor Fuses (10 Nos each type)	Vendor to offer
5.1.2.8	Special Fuses (10 Nos each type)	Vendor to offer
5.1.2.9	Circuit Breakers (1 No each type)	Vendor to offer
5.1.2.10	Main Power Switch (1 No each type)	Vendor to offer
5.1.2.11	Encoders (1 No each type)	Vendor to offer
5.1.2.12	Scanning Head Unit for Linear Scales (1 No each type)	Vendor to offer
5.1.2.13	Spare Hard disk loaded with Ghost of the machine after final commissioning	Vendor to offer
5.1.2.14	I/O Modules of PLC (1 No each type)	Vendor to offer
5.1.2.15	Power Module & Control Cards for Main Drive as well as Feed Drives (1 No each type)	Vendor to offer
5.1.2.16	Limit Switches & Micro Switches (10 Nos each type)	Vendor to offer
5.1.2.17	Backup batteries (1 No each type)	Vendor to offer
5.1.2.18	Hand held unit	Vendor to offer
5.1.2.19	Memory cards with loaded data (1 No each type)	Vendor to offer
5.2	All types of spares for total machine and accessories should be available for at least ten years after supply of the machine. If machine or control is likely to become obsolete in this period, the vendor should inform BHEL sufficiently in advance and provide drawings of parts / details of spares & suppliers to enable BHEL to procure these in advance, if required	Vendor to confirm
5.3	Vendor to confirm that complete list of spares for machine and accessories, along with specification / type / model, and name & address of the spare supplier shall be furnished along with documentation to be supplied with the machine	Vendor to confirm

SL. NO.	BHEL TECHNICAL SPECIFICATION		VENDOR'S OFFER WITH TECHNICAL DETAILS & REMARKS
6	DOCUMENTATION : THREE SETS OF FOLLOWING DOCUMENTS (HARD COPIES & SOFT COPIES) IN ENGLISH LANGUAGE SHOULD BE SUPPLIED ALONG WITH THE MACHINE		Vendor to confirm
6.1	Operating manuals of Machine & CNC system	Vendor to offer	
6.2	Programming Manuals of Machine & CNC system	Vendor to offer	
6.3	Detailed Maintenance manual of machine and supplied systems.	Vendor to offer	
6.4	Maintenance Interface & commissioning manuals, PLC programming manual for CNC system, Interface & commissioning manuals for spindle ,feed drives and auxiliary drive.	Vendor to offer	
6.5	Manufacturing drawings for all supplied clamping jaws and its lead screws, tool holders, coolant connections, fixtures etc.	Vendor to offer	
6.6	Catalogues, Operation & Maintenance Manuals of all bought out items including drawings, wherever applicable.	Vendor to offer	
6.7	Detailed specification of all rubber items and hydraulic/lube fittings	Vendor to offer	
6.8	Operating Manuals, Maintenance Manuals & Catalogues for supplied accessories viz. Voltage Stabilizer, Isolation Transformer, Air-Compressor, etc.	Vendor to offer	
6.9	Program print-outs (hard copy) for PLC of main machine and auxiliary systems (if used) alongwith Comments, cross reference list and Input/Output list in English.	Vendor to offer	
6.10	PLC programs, NC data, PLC data, Alarms & messages and all the data backup (which is required in the event of total data loss) shall be supplied on CD.	Vendor to offer	
6.11	Complete ghost back-up of hard disk on CD and clearly written Instructions of taking back-up and reloading on new hard disk.	Vendor to offer	
6.12	Complete list of parts/items(Bill of materials) used in the machine in English language along with Make, Specifications, Type No. and Supplier's Address.	Vendor to offer	
6.13	Electrical Schematic Diagrams, Wiring Diagrams, Junction Box Layouts, Connector Diagrams and Cable Layouts of the machine in English.	Vendor to offer	
6.14	Drawings of machine assemblies/sub-assemblies/parts including Pneumatic/ Coolant / Hydraulic circuit diagrams. All Assembly/ Sub Assembly Drawings shall be supplied with the part list marked on it in English.	Vendor to offer	
6.15	One additional set of all the above documentation on CD.	Vendor to offer	
7	PROVE-OUT MACHINING OF BHEL COMPONENT		

SL. NO.	BHEL TECHNICAL SPECIFICATION		VENDOR'S OFFER WITH TECHNICAL DETAILS & REMARKS
7.1	<p>Drawings of proveout components are enclosed. Job setting plan, Machining process plan & Requirement of Tools etc. for machining of proveout components shall be discussed and mutually agreed (Final proveout component drawing no. may change, however, the machining features of the changed components shall be in line with the original component drawing). <u>Rough & Finish turning of faces, outer diameters, bores & blade grooves</u> of prove out component detailed at Clause No 7.4 shall be done by Vendor at BHEL works to the specified design accuracy and surface finish, using cutting tools and CNC programs to be provided by the vendor to prove the machine after complete erection. <u>Material for the proveout components in ready to turn condition shall be provided by BHEL.</u> Vendor shall submit final job setting plan, machining process plan, tool layout & list with complete description, time study etc. for the proveout machining within two months of placement of order. Vendor shall submit CNC programs prior to start of erection of Machine at BHEL works.</p>	Vendor to accept & offer	
7.2	During proveout, all tools should be preset by using supplied Tool offset Measuring System	Vendor to accept	
7.3	Vendor shall be responsible, financially or otherwise, for any deviation/ rejection in proveout component to the extent of cost of Casting/Forging, due to wrong machining or malfunctioning of the machine during proveout machining and also for the delay in machining due to improper recommended tooling etc..The cost of such deviation / rejection, if any, shall be refunded by the vendor to BHEL.	Vendor to accept & confirm	
7.4	<p>Component Name : Frame-6 GT Compressor Casing</p> <p>Machining Drawing : 0-35102-67001-02</p> <p>Casting Drawing : 0-35102-67001-05</p> <p>Raw Material : Grey Cast Iron (ASTM-A395)</p>	Vendor to accept & confirm	
8	TRAINING & PRE-DISPATCH INSPECTION :		
8.1	<p>Four BHEL Persons should be trained at vendor's works for the area & period given below: (a) CNC Programming for the machine, measuring system, etc. (Period 3 weeks) (b) Electrical, Electronic & CNC maintenance for machine & other supplied equipments (Period 2 weeks) (c) Mechanical & Hydraulic maintenance of the machine & other supplied equipments (Period 2 weeks) (d) Operation of the machine & other supplied equipments (Period 2 weeks) Pre-dispatch inspection (ref. Sl.No. 12.1) of the machine shall also be carried out by the team during their stay at vendor's works for the training. Vendor may specify days required for pre-dispatch inspection. BHEL reserves the right to choose no. of persons, field & period of training, out of above, while deputing their engineers for training.</p>	Vendor to offer	
8.2	Air-fare, boarding & lodging for the trainees shall be borne by BHEL.	For vendor's information.	
8.3	Competent, English speaking experts shall be arranged by the vendor for satisfactory & effective training of BHEL personnel.	Vendor to accept & confirm	

SL. NO.	BHEL TECHNICAL SPECIFICATION		VENDOR'S OFFER WITH TECHNICAL DETAILS & REMARKS
8.4	Vendor should commit & offer to organize training of Electronics Engineer and Programmer at the CNC System Manufacturer's works/training school for advanced features and specialized training, if so required by BHEL.	Vendor to offer	
8.5	Training charges, if any, for training requirement at Sl.No. 8.1 & 8.4 should also be quoted on per Man-day basis so that training charges can be derived for the agreed period & persons, in case of any change.	Vendor to offer	
9	FOUNDATION		
9.1	Vendor shall submit the preliminary General Arrangement Drawing & Layout Drawing for getting BHEL's approval within two months from the date of Letter of Intent (LOI) / P.O. Complete Foundation details viz. static / dynamic load details etc. and Final Layout drawings shall be submitted by the supplier within two months after getting BHEL's approval. The layout should consist of all requirements pertaining to complete machine including space requirement for Voltage Stabilizer, Isolation Transformer, Air compressor, Chip Bin & all other accessories/ attachments/ offered items.BHEL shall design & construct complete foundation for the machine as per Final Layout & other details provided by vendor. The vendor shall also indicate detailed specifications of grouting compound and grouting procedure etc. if any specifically desired for foundation bolts of the machine.	Vendor to accept & offer	
10	ERECTION & COMMISSIONING		
10.1	Supplier to take full responsibility for carrying out the erection, start up, testing of machine, it's control system & all types of other supplied equipment, machining of test pieces etc. Service requirement like power, air & water shall be provided by BHEL at only one point to be indicated by supplier in their foundation/layout drawings. Other requirements like crane and helping personnel shall also be provided by BHEL. Details of these requirements should be informed by vendor in advance. The available crane capacity at the proposed location of the machine will be 100 Ton. The vendor will ensure to make requisite arrangement for lifting of heavier consignment/ items/ assembly of the machine not getting covered by this capacity.	Vendor to accept.	
10.2	Erection & Commissioning of Voltage stabilizer, Isolation Transformer , Air Compressor and other accessories/attachments with all electrical & mechanical connections shall also be responsibility of the vendor.	Vendor to offer	
10.3	Successful proving of BHEL components by the supplier shall be considered as part of commissioning for the machine . All tests, as mentioned at Sl. No. 12 (Machine Acceptance) and testing/demonstration of tele-diagnostic service etc. shall also be part of the commissioning activity.	Vendor to offer	
10.4	Tools, Tackels, Test Mandrels, instruments and other necessary equipment including Laser equipment required to carry out all erection & commissioning activities should be arranged and brought by the supplier.	Vendor to accept	
10.5	Commissioning spares, required for commissioning of the machine within stipulated time, shall be brought by the supplier on returnable basis.	Vendor to accept	

SL. NO.	BHEL TECHNICAL SPECIFICATION		VENDOR'S OFFER WITH TECHNICAL DETAILS & REMARKS
10.6	All cover plates, plates for chutes for chips flow etc., required for the machine and its peripherals/accessories shall be supplied by the vendor.	Vendor to accept	
10.7	Schedule of Erection and Commissioning shall be submitted with the offer.	Vendor to submit	
10.8	Terms & conditions for Erection & Commissioning should be furnished in detail separately by vendor along with offer.	Vendor to submit	
10.9	Portion, if any, of the machine, accessories/attachments and other supplied items where paint got rubbed or peeled off during transit or erection should be re-painted and matched with the original adjoining paint by the vendor. For this purpose, the vendor should supply sufficient quantity of touch-up paint of various colours/shades of paints used. The vendor shall ensure performing touching after commissioning but before final acceptance.	Vendor to offer	
11	AMBIENT CONDITIONS & THERMAL STABILITY		
11.1	Total machine including all supplied items should work trouble free and should give specified accuracies under existing power supply and ambient operating conditions, as mentioned below at Sl. Nos. 11.2	Vendor to accept & confirm	
11.2	Ambient Operating Conditions: Temperature = 5 to 45 degree Celsius Relative Humidity = 95% max. Weather conditions are tropical. Atmosphere may be dust laden during some part of the year. Machine shall be kept in the normal shop floor condition without any temperature controlled enclosure/shop. Max. temperature variation is 25 deg Celsius in 24 hours.	Vendor to accept	
11.3	Thermal Stability: Thermal Stability of the complete machine and all supplied items keeping in view the specified Ambient Conditions, accuracies, requirements of BHEL components and trouble free operation of the machine should be ensured by vendor. Since the machine shall be installed in shop with operating conditions as per Sl.No. 11.2, the vendor shall ensure achieving the drawing accuracies on the job throughout the year. Vendor to confirm that machine is suitable for above and details of provisions on the machine for the suitability should be furnished by Vendor.	Vendor to offer & confirm	
11.4	The machine should be suitable for continuous operation to its full capacity for 24 hours a day and 7 days a week throughout year. Vendor to ensure and confirm the same.	Vendor to offer & confirm	
12	MACHINE ACCEPTANCE (TESTS/ACTIVITIES TO BE PERFORMED & DEMONSTRATED BY THE VENDOR)	Vendor to note	
12.1	TESTS/ACTIVITIES TO BE CARRIED OUT AT VENDOR'S WORKS ON THE MACHINE BEFORE DISPATCH :	Vendor to note	
12.1.1	Demonstration of specified/offered Geometrical accuracies as per clause 2.27.1	Vendor to accept & confirm	
12.1.2	Demonstration of specified/offered Positioning accuracies as per clause 2.27.2	Vendor to accept & confirm	
12.1.3	The machine should be tested for continuous running of 48 hrs. If any break down occurs during this test, the test should be repeated for 48 hrs from that time.	Vendor to accept & confirm	

SL. NO.	BHEL TECHNICAL SPECIFICATION	VENDOR'S OFFER WITH TECHNICAL DETAILS & REMARKS
12.1.4	Demonstration of all features of the machine, control system & accessories and troubleshooting	Vendor to accept & confirm
12.1.5	Machining of test piece as per AFNOR/ISO/NAS for turning operations etc. Vendor to supply test pieces.	Vendor to accept & confirm
12.2	TESTS/ACTIVITIES TO BE CARRIED OUT AT BHEL WORKS WHILE COMMISSIONING THE MACHINES:	Vendor to note
12.2.1	Demonstration of specified/offered Geometrical accuracies as per clause 2.27.1	Vendor to accept & confirm
12.2.2	Demonstration of specified/offered Positioning accuracies as per clause 2.27.2	Vendor to accept & confirm
12.2.3	Full load test to demonstrate the maximum power & cutting capacity of the machine.	Vendor to accept & confirm
12.2.4	The machine should be tested for continuous running of 48 hrs. If any break down occurs during this test, the test should be repeated for 48 hrs from that time.	Vendor to accept & confirm
12.2.5	Demonstration of all features of the machine, control system & accessories, and troubleshooting to the satisfaction of BHEL for efficient and effective use of the machine.	Vendor to accept & confirm
12.2.6	Demonstration by actual use of all supplied accessories to their full capacity for required applications.	Vendor to accept & confirm
12.2.7	Machining of test piece as per AFNOR/ISO/NAS for turning operations etc. Vendor to supply test pieces.	Vendor to accept & confirm
12.2.8	Successful machining of proveout components to required drawing accuracies as per Sl. No. 7.0	Vendor to accept & confirm
12.2.9	Two weeks of supervision by Vendor of independent operation of machine by BHEL after job proveout.	Vendor to accept & confirm
12.2.10	Training of BHEL machine operators in operation of complete machine & accessories etc by the supplier's experts / engineers during their stay at BHEL works.	Vendor to accept & confirm
13	PACKING	
	Sea worthy & rigid packing for machine, control and all other supplied items to avoid any damage/loss in transit. All small loose items should be suitably packed in boxes.	Vendor to offer & confirm
14	GUARANTEE	
	Guarantee for complete machine and all supplied systems/accessories / attachments /equipments/items for 24 months from the date of acceptance of the machine.	Vendor to offer
15	GENERAL	
15.1	Machine Model No.	Vendor to inform
15.2	Total connected load (KVA)	Vendor to inform
15.3	Total Space required (Length, Width, Height) for complete machine, accessories/attachments and other supplied items like Voltage Stabilizer, Isolation Transformer & Air compressor etc.	Vendor to inform

SL. NO.	BHEL TECHNICAL SPECIFICATION		VENDOR'S OFFER WITH TECHNICAL DETAILS & REMARKS
15.4	Painting of Machine / Electrical Panels : Colour as per vendor standard	Vendor to inform	
15.5	Total weight of the machine	Vendor to inform	
15.6	Weight of heaviest part of machine	Vendor to inform	
15.7	Weight of the heaviest assembly of the Machine	Vendor to inform	
15.8	Dimensions of largest part of the machine	Vendor to inform	
15.9	Vendor to submit reference list of customers where similar machines have been supplied mentioning broad specifications of the supplied machine i.e. Model, CNC System, Table Dia, Max. Turning Dia, Max. Turning Height, RPM, Load Carrying Capacity, Main Drive Rating and detail of accessories/attachments, if any, etc.	Vendor to submit	
15.10	Detailed catalogues, sketches/drawings/photographs pertaining to the offered machines and accessories/attachments/items should be submitted with the offer.	Vendor to submit	
15.11	Hydraulic, Pneumatic & Oil pipings should be preferably metallic except places where flexible pipings are essential. All the pipes required for the same shall be supplied by the vendor.	Vendor to confirm	
15.12	All Cables and Hoses etc. should be well supported & protected in trays/brackets/drag chains etc.	Vendor to confirm	
15.13	Total Height of the machine when ram is at Z home and cross rail is set for facing on maximum height 2500mm.	Vendor to inform	
15.14	Ladder is to be provided to access the machine elements located at the top of the column for maintainance purpose	Vendor to offer & confirm	

CNC VTL : TABLE DIA - 2500 MM

ANNEXURE - I				
TOOLING LIST FOR VERTICAL LATHE - TABLE DIA: 2500MM				
SNO	DESCRIPTION OF TOOL	QTY	DESCRIPTION OF INSERT	QTY
EXTERNAL TURNING HOLDERS WITH RHOMBIC INSERTS				
1	PCLNL4040S19	2	CNMG 19 06 12 of Grade GC 4030 & GC 3040 of Sandvik or equivalent grade of other reputed suppliers	50 EACH
2	PCLNR4040S19	2		
3	PCLNL3232P19	2		
4	PCLNR3232P19	2		
EXTERNAL TURNING HOLDERS WITH DIAMOND INSERTS				
1	PDJNL3232P15	2	DNMG 15 06 08 of Grade GC 4030 & GC 3040 of Sandvik or equivalent grade of other reputed suppliers	50 EACH
2	PDJNR3232P15	2		
3	PDJNL2525M11	2	DNMG 11 04 08 of Grade GC 4030 & GC 3040 of Sandvik or equivalent grade of other reputed suppliers	
4	PDJNR2525M11	2		
EXTERNAL TURNING HOLDERS WITH ROUND INSERTS				
1	PRGNL4040S25	2	RNMG 25 09 00 of Grade GC 4030 & GC 3040 of Sandvik or equivalent grade of other reputed suppliers	50 EACH
2	PRGNR4040S25	2		
3	PRGNL3232P19	2	RNMG 19 06 00 of Grade GC 4030 & GC 3040 of Sandvik or equivalent grade of other reputed suppliers	50 EACH
4	PRGNR3232P19	2		
5	PRGNL2525M12	2	RNMG 12 04 00 of Grade GC 4030 & GC 3040 of Sandvik or equivalent grade of other reputed suppliers	50 EACH
6	PRGNR2525M12	2		
EXTERNAL TURNING HOLDERS WITH SQUARE INSERTS				
1	PSBNL4040S19	2	SNMG 19 06 12 of Grade GC 4030 & GC 3040 of Sandvik or equivalent grade of other reputed suppliers	50 EACH
2	PSBNR4040S19	2		
3	PSBNL3232P19	2		
4	PSBNR3232P19	2		
NOTE: ALL TOOLING SHALL BE OF REPUTED INTERNATIONAL BRANDS LIKE SANDVIK, ISCAR, SECO OR EQUIVALENT ONLY				

100L9-20-156-0 ON 'D' 2 OF 3

6.3 3.2 1.6

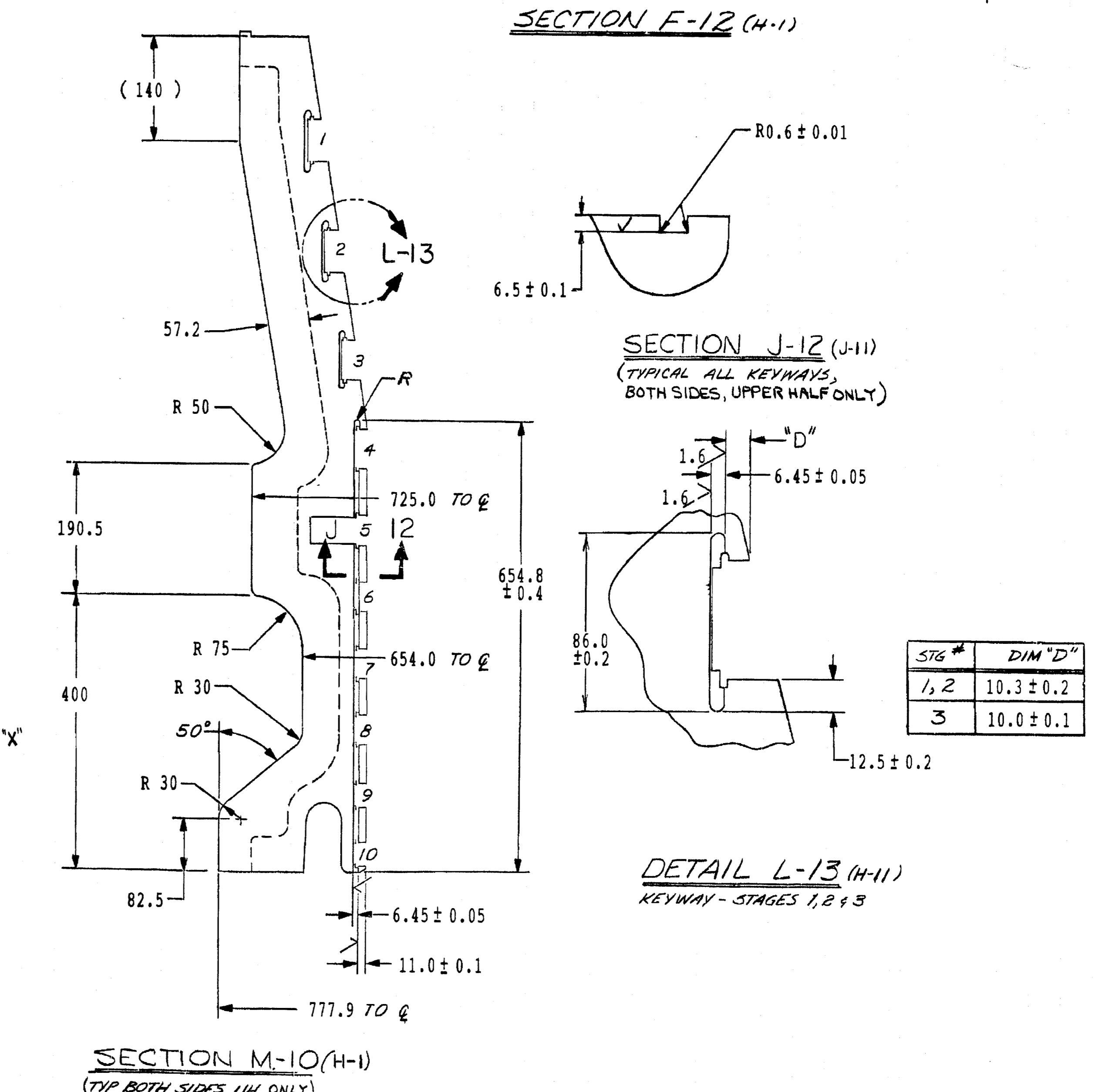
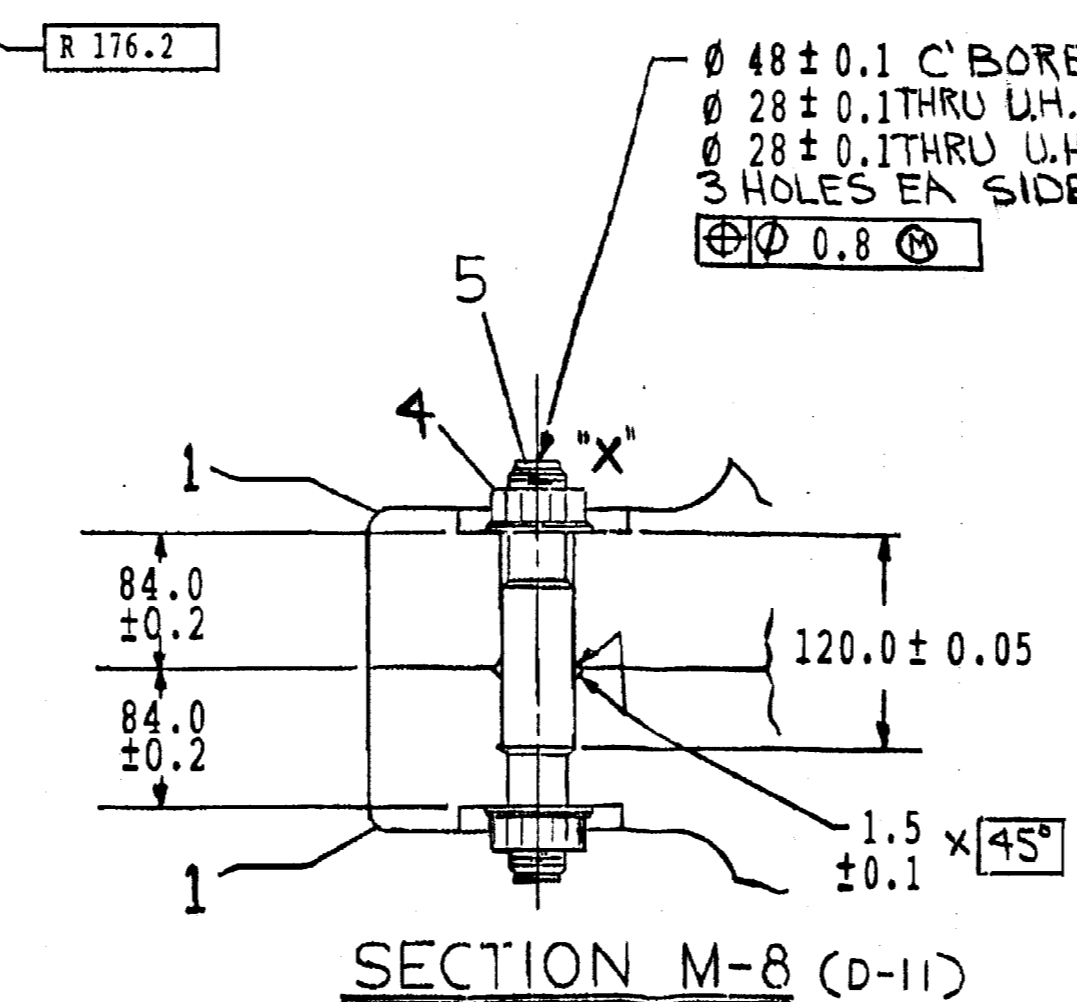
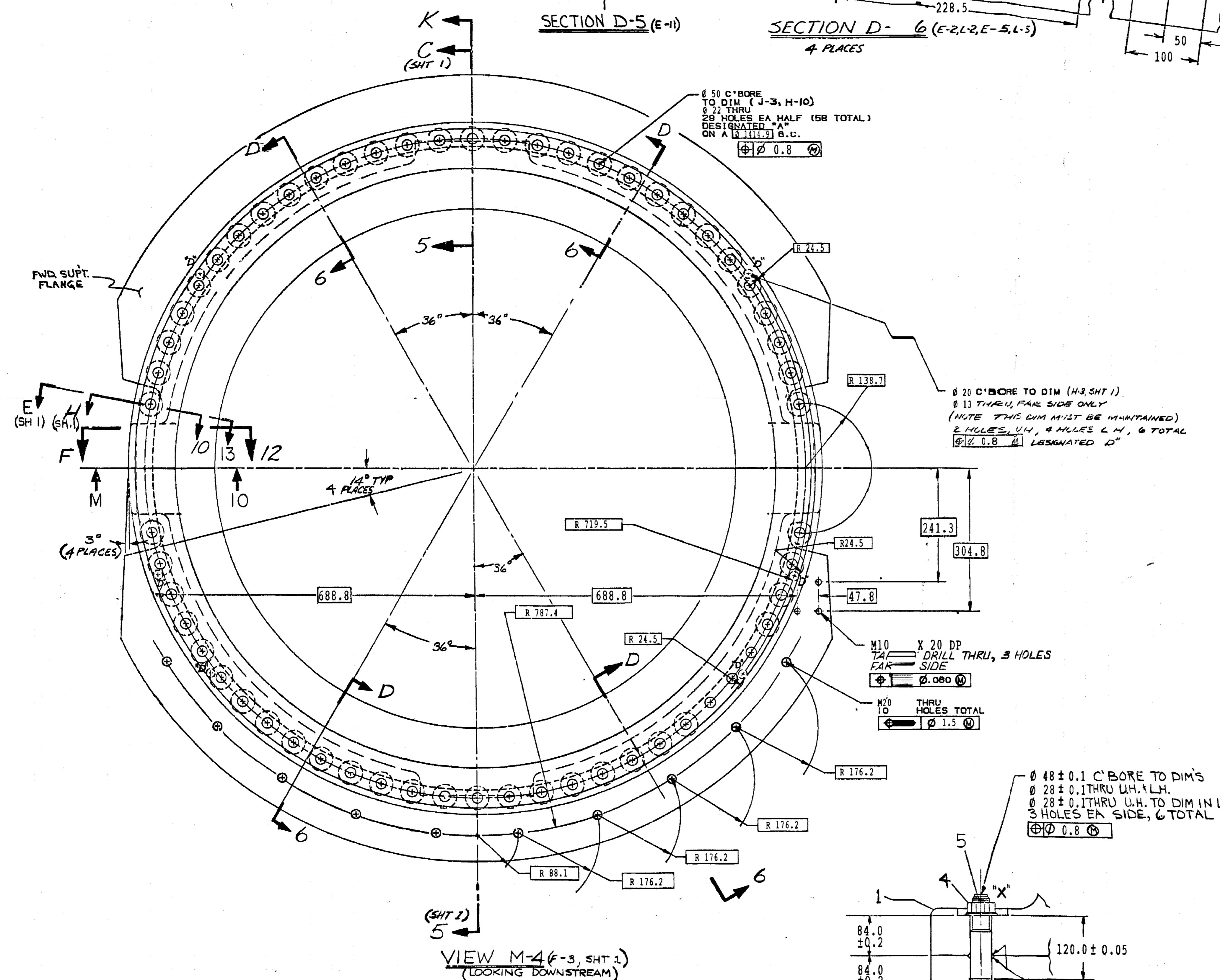
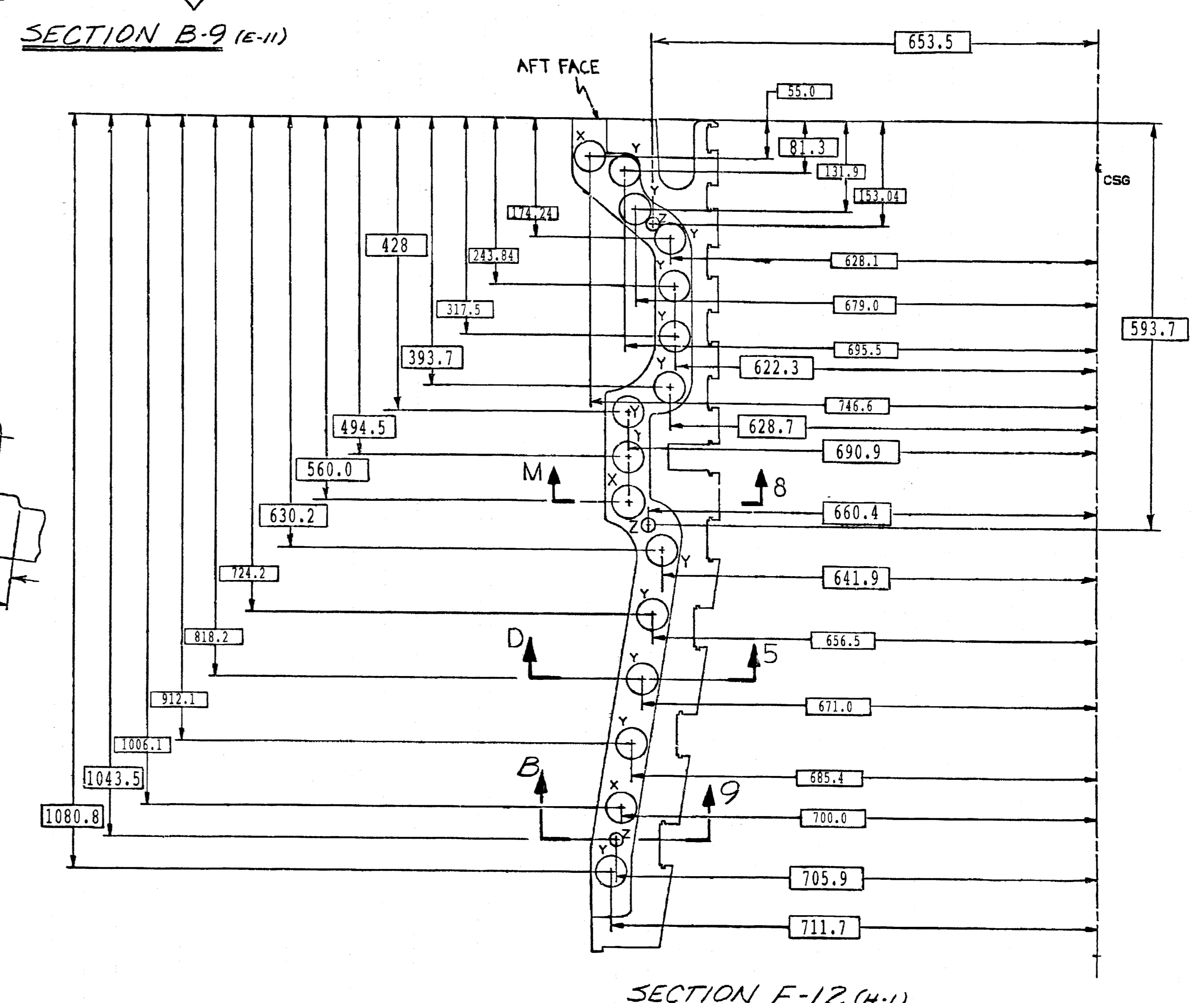
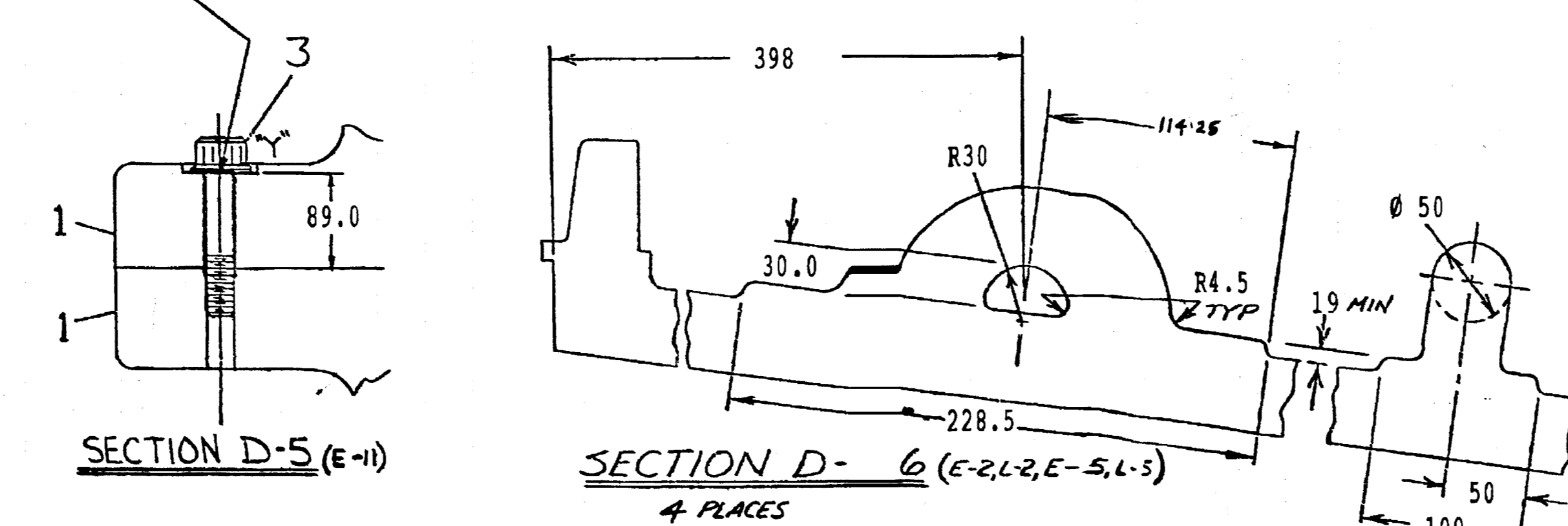
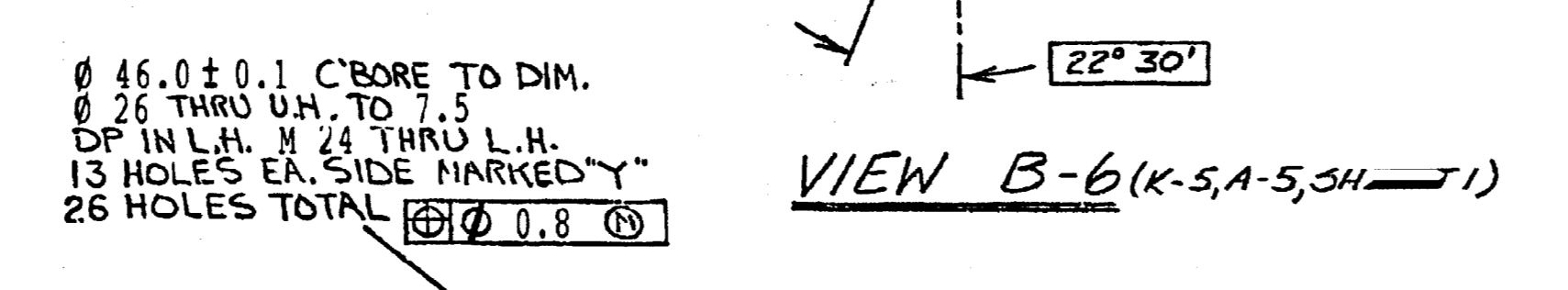
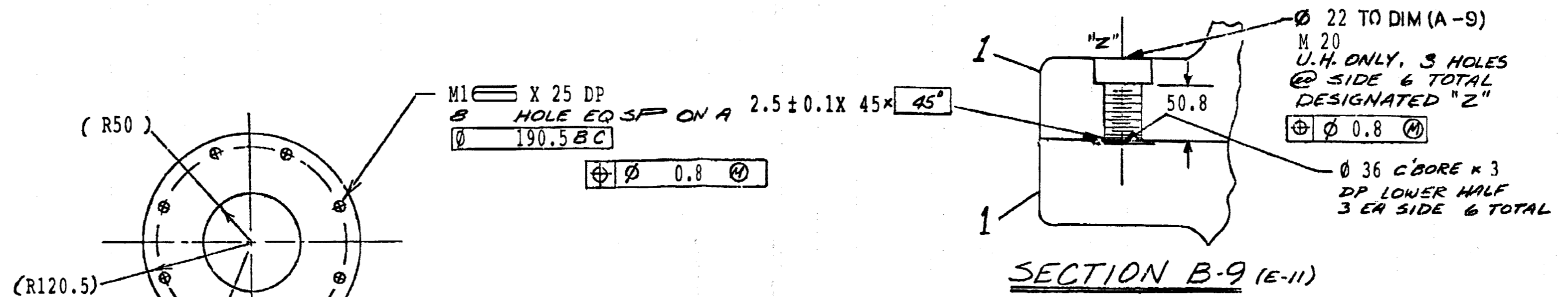

THE INFORMATION ON THIS DOCUMENT IS THE PROPERTY OF BHARAT HEAVY ELECTRICALS LIMITED. IT MUST NOT BE USED DIRECTLY OR INDIRECTLY IN ANY WAY DETRIMENTAL TO THE INTEREST OF THE COMPANY.

GENERAL DIMENSIONAL LIMITS, FITS & TOLERANCES AS PER HYD230261

REV	DATE	ALTERED	CHD/APPD	REV	DATE	ALTERED	CHD/APPD	REV	DATE	ALTERED	CHD/APPD	REV	DATE	ALTERED	CHD/APPD	REV	DATE	ALTERED	CHD/APPD	REV	DATE	ALTERED	CHD/APPD	REV	DATE	ALTERED	CHD/APPD	REV	DATE	ALTERED	CHD/APPD	REV	DATE	ALTERED	CHD/APPD	
06	11.11.94	CHD/APPD	...	05	8.2.95	CHD/APPD	...	04	11.16.94	CHD/APPD	...	03	5.3.92	CHD/APPD	...	02	9.11.90	CHD/APPD	...	01																

TYPE OF PRODUCT OR NAME OF CUSTOMER/PROJECT		NAME		SIGN.		DATE		REV.	
GAS TURBINE FR-6B		BHARAT HEAVY ELECTRICALS LIMITED		SCS		19.07.88		NA	
HYDERABAD		HYDERABAD		S. KRISHNA (M)		19.07.88		NA	
DEPT. UNTO. DING.		SCALE		WEIGHT (KG)		REF. TO ASSY. Dwg.		NO. OF TENS	
CODE 433		NTS		1800		NA		NA	
TITLE		DRAWING NO.		REV.		NO. OF SH.		REV.	
CASE, ASSY-COMPR		0-351-02-67001		06		2		3	

10019-20-196-0 ON DRG E 30 E HS

6.3 / 3.2 / 1.6

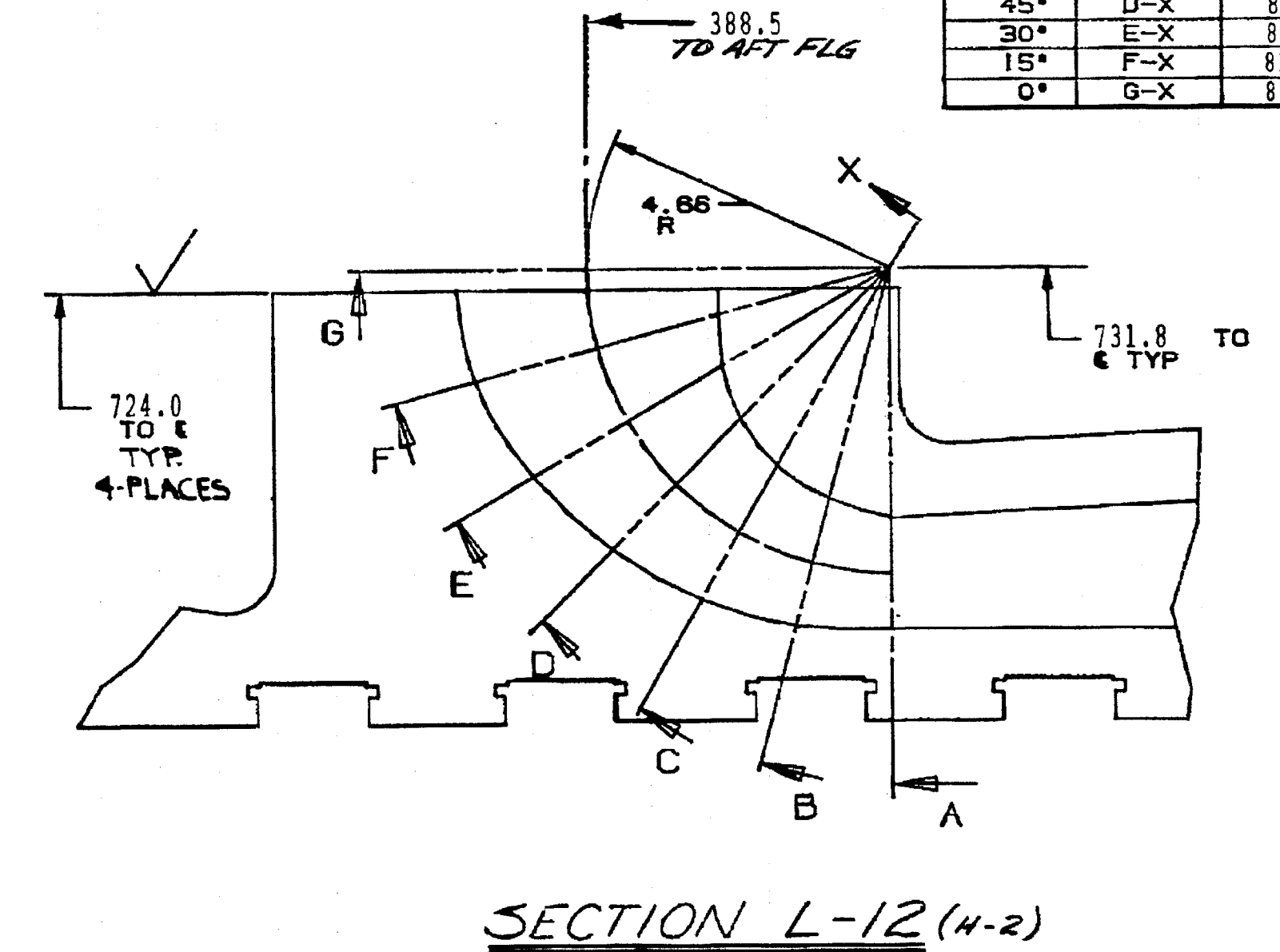
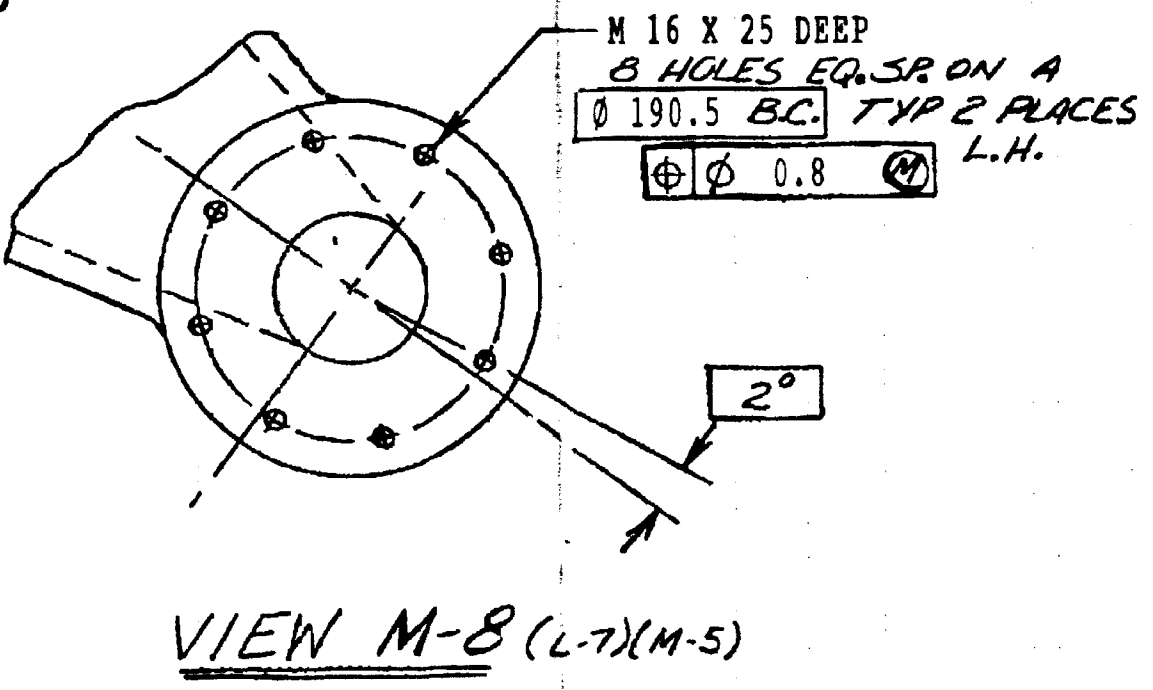
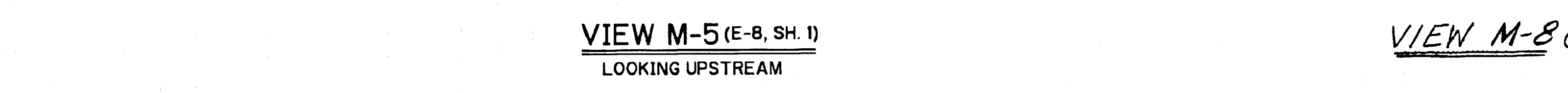
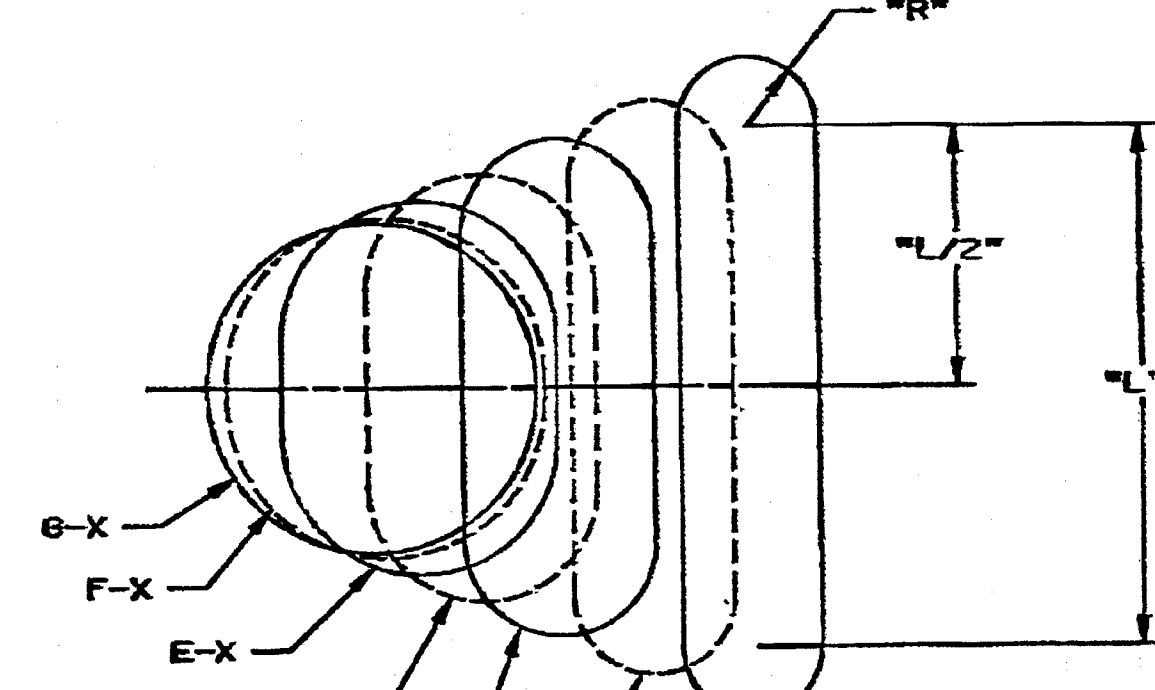
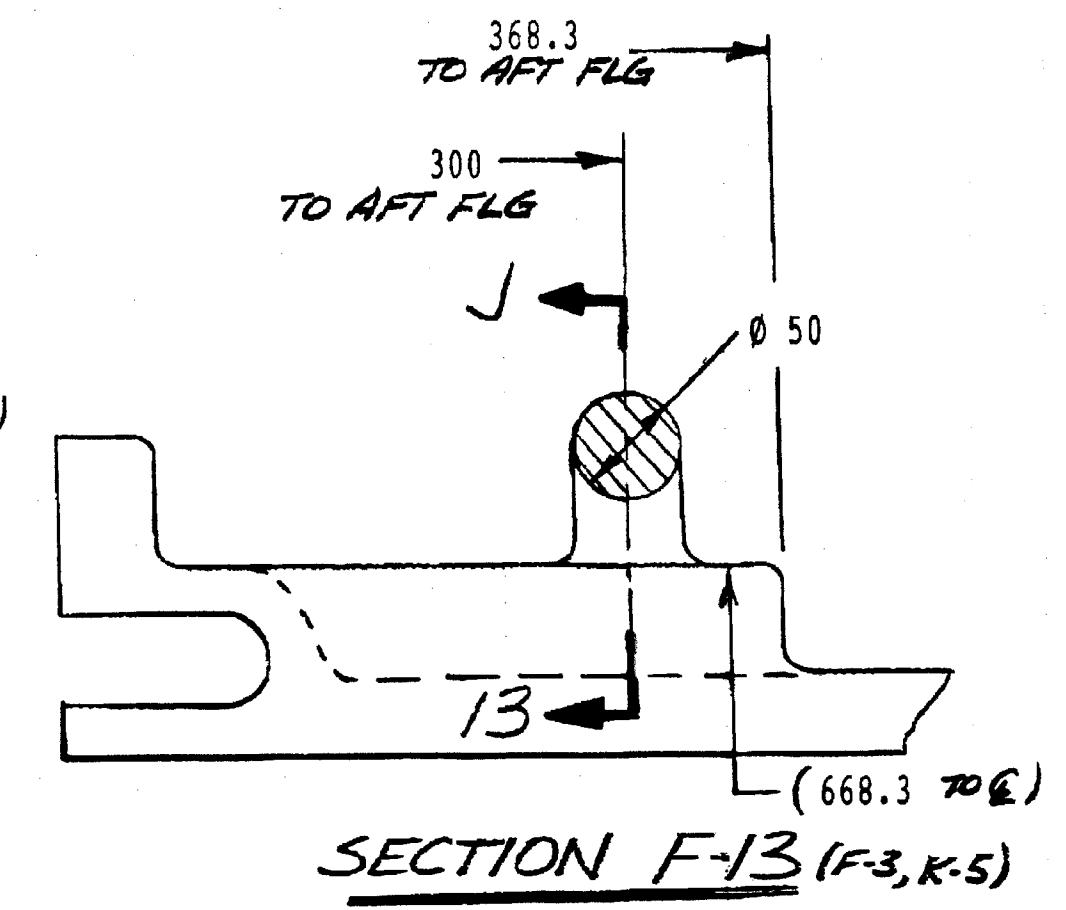
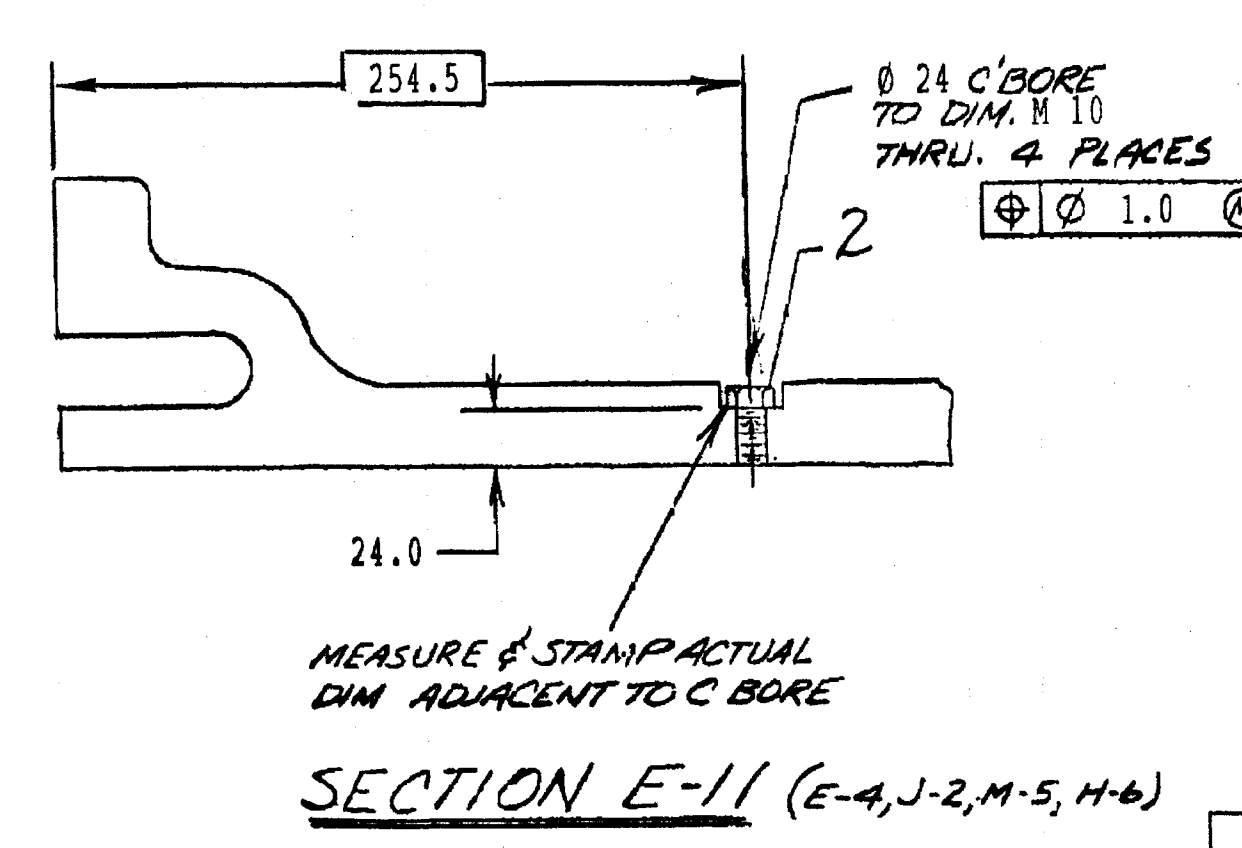
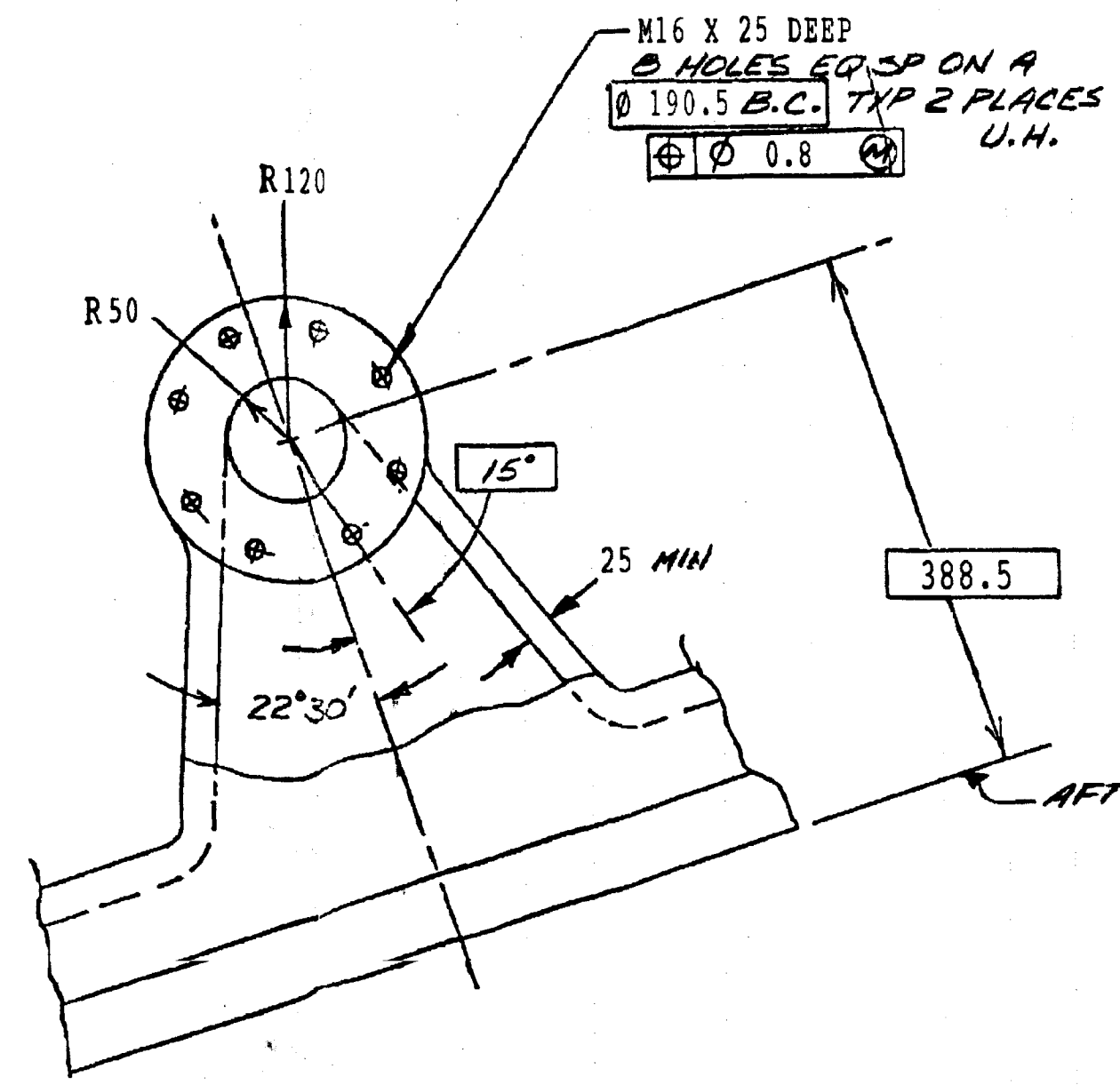
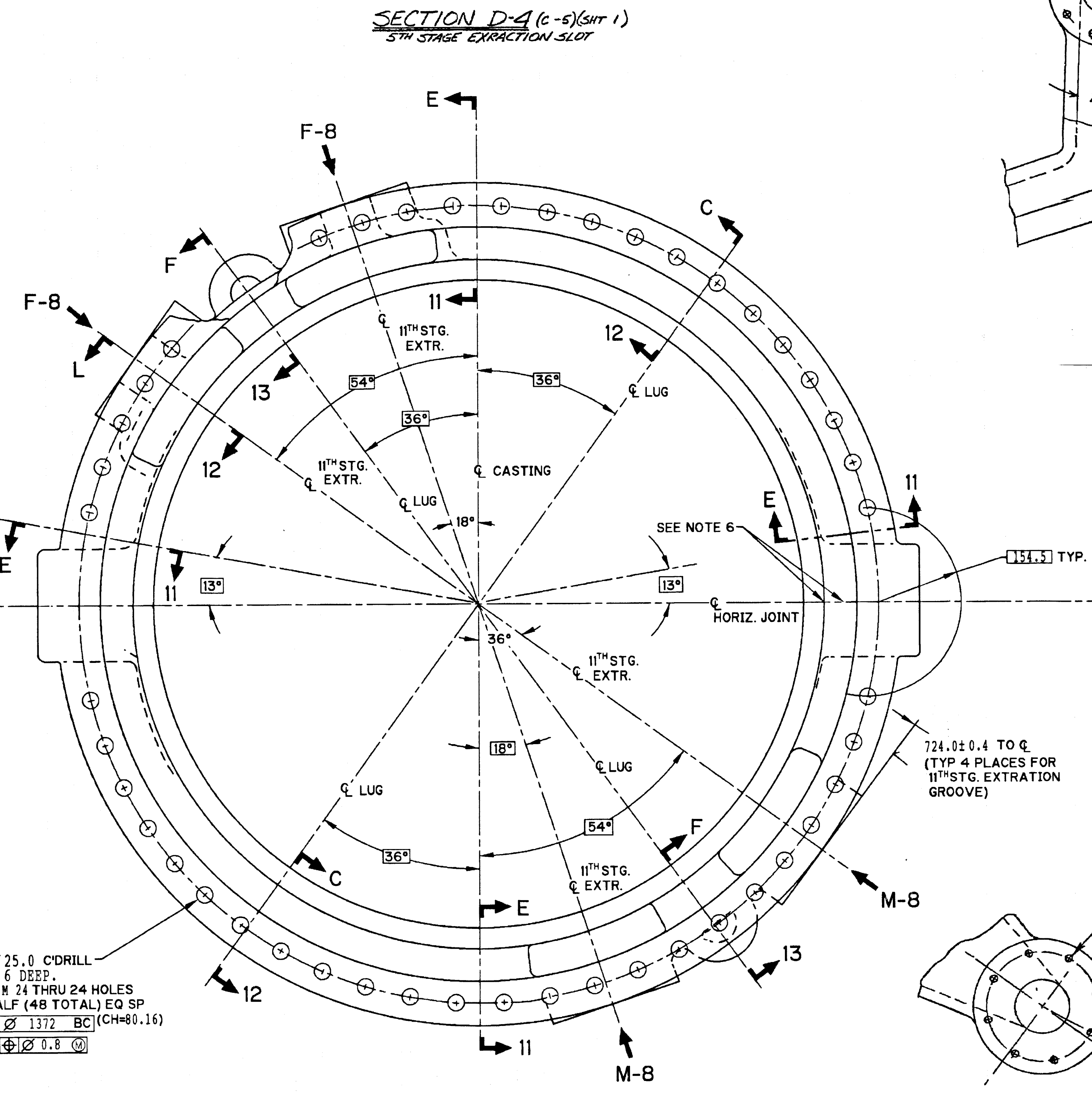
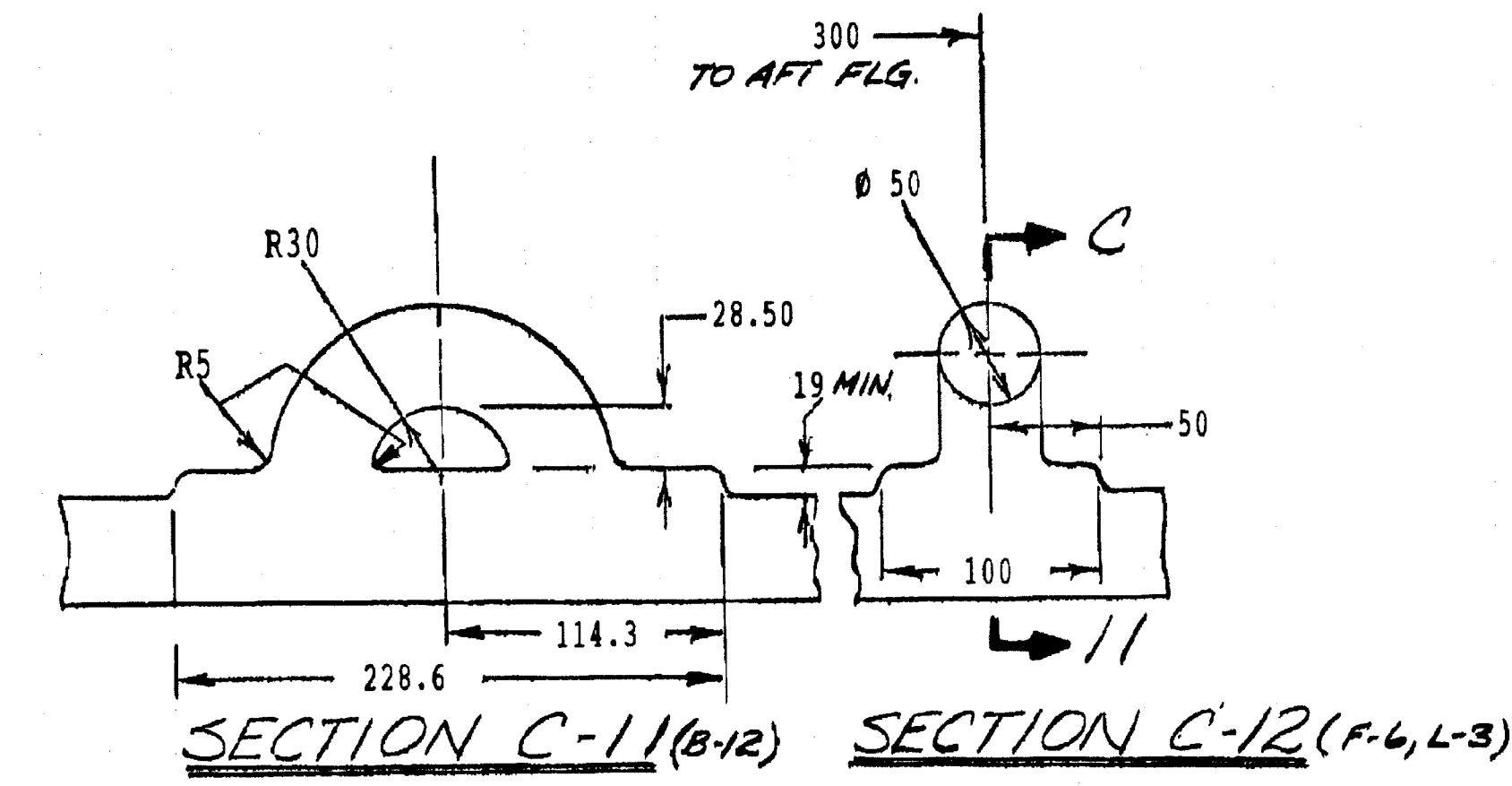
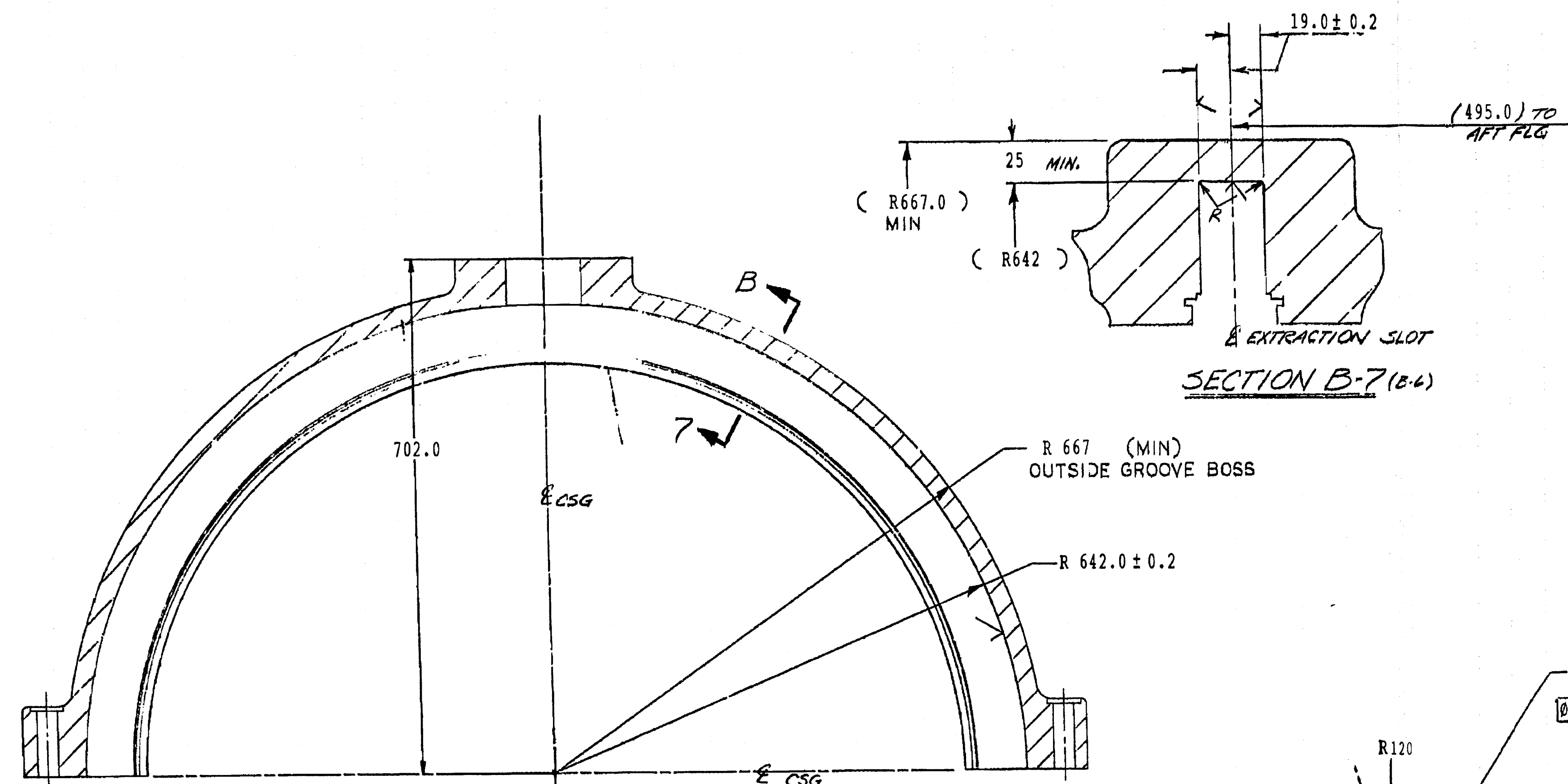

ANGLE	SECTION	AREA (REF) SQ. IN.	R (F-12) MIN ± 1/2	L (F-12)
90°	A-X	8277.5	21.5	80.3
75°	B-X	8796.8	25.0	63.5
60°	C-X	8264.5	29.5	47.0
45°	D-X	8219.9	35.0	30.5
30°	E-X	8200.0	42.0	15.5
15°	F-X	8181.0	48.8	3.5
0°	G-X	8110.0	50.8	0.0

Ø 25.0 C'DRILL
6 DEEP.
M 24 THRU 24 HOLES
EA HALF (48 TOTAL) EQ SP
ON A Ø 137.2 BC (CH=80.16)
Ø 0.8

THE INFORMATION ON THIS DOCUMENT IS THE PROPERTY OF BHARAT HEAVY ELECTRICALS LIMITED. IT MUST NOT BE USED DIRECTLY OR INDIRECTLY IN ANY WAY DETRIMENTAL TO THE INTEREST OF THE COMPANY.
 GENERAL DIMENSIONAL LIMITS, FITS & TOLERANCES AS PER HYD230261.
 INVENTORY NO. 10019-20-196-0
 REV. DATE 19.07.88
 CHD/APPD SCS
 1202019-20-196-0-III

TYPE OF PRODUCT OR NAME OF CUSTOMER/PROJECT		GAS TURBINE FR-6B	
DEPT. CODE	UNTO. DIMS	SCALE	WEIGHT (KG)
423	4/1/1	NTS	1800
REV. DATE	ALTERED BY	REV. DATE	ALTERED BY
16	S.S.1.2000	10	CHD/APPD S.S.1.2000
17	CHD/APPD S.S.1.2000	11	CHD/APPD S.S.1.2000
18	CHD/APPD S.S.1.2000	12	CHD/APPD S.S.1.2000
19	CHD/APPD S.S.1.2000	13	CHD/APPD S.S.1.2000
20	CHD/APPD S.S.1.2000	14	CHD/APPD S.S.1.2000
21	CHD/APPD S.S.1.2000	15	CHD/APPD S.S.1.2000
22	CHD/APPD S.S.1.2000	16	CHD/APPD S.S.1.2000
23	CHD/APPD S.S.1.2000	17	CHD/APPD S.S.1.2000
24	CHD/APPD S.S.1.2000	18	CHD/APPD S.S.1.2000
25	CHD/APPD S.S.1.2000	19	CHD/APPD S.S.1.2000
26	CHD/APPD S.S.1.2000	20	CHD/APPD S.S.1.2000
27	CHD/APPD S.S.1.2000	21	CHD/APPD S.S.1.2000
28	CHD/APPD S.S.1.2000	22	CHD/APPD S.S.1.2000
29	CHD/APPD S.S.1.2000	23	CHD/APPD S.S.1.2000
30	CHD/APPD S.S.1.2000	24	CHD/APPD S.S.1.2000
31	CHD/APPD S.S.1.2000	25	CHD/APPD S.S.1.2000
32	CHD/APPD S.S.1.2000	26	CHD/APPD S.S.1.2000
33	CHD/APPD S.S.1.2000	27	CHD/APPD S.S.1.2000
34	CHD/APPD S.S.1.2000	28	CHD/APPD S.S.1.2000
35	CHD/APPD S.S.1.2000	29	CHD/APPD S.S.1.2000
36	CHD/APPD S.S.1.2000	30	CHD/APPD S.S.1.2000
37	CHD/APPD S.S.1.2000	31	CHD/APPD S.S.1.2000
38	CHD/APPD S.S.1.2000	32	CHD/APPD S.S.1.2000
39	CHD/APPD S.S.1.2000	33	CHD/APPD S.S.1.2000
40	CHD/APPD S.S.1.2000	34	CHD/APPD S.S.1.2000
41	CHD/APPD S.S.1.2000	35	CHD/APPD S.S.1.2000
42	CHD/APPD S.S.1.2000	36	CHD/APPD S.S.1.2000
43	CHD/APPD S.S.1.2000	37	CHD/APPD S.S.1.2000
44	CHD/APPD S.S.1.2000	38	CHD/APPD S.S.1.2000
45	CHD/APPD S.S.1.2000	39	CHD/APPD S.S.1.2000
46	CHD/APPD S.S.1.2000	40	CHD/APPD S.S.1.2000
47	CHD/APPD S.S.1.2000	41	CHD/APPD S.S.1.2000
48	CHD/APPD S.S.1.2000	42	CHD/APPD S.S.1.2000
49	CHD/APPD S.S.1.2000	43	CHD/APPD S.S.1.2000
50	CHD/APPD S.S.1.2000	44	CHD/APPD S.S.1.2000
51	CHD/APPD S.S.1.2000	45	CHD/APPD S.S.1.2000
52	CHD/APPD S.S.1.2000	46	CHD/APPD S.S.1.2000
53	CHD/APPD S.S.1.2000	47	CHD/APPD S.S.1.2000
54	CHD/APPD S.S.1.2000	48	CHD/APPD S.S.1.2000
55	CHD/APPD S.S.1.2000	49	CHD/APPD S.S.1.2000
56	CHD/APPD S.S.1.2000	50	CHD/APPD S.S.1.2000
57	CHD/APPD S.S.1.2000	51	CHD/APPD S.S.1.2000
58	CHD/APPD S.S.1.2000	52	CHD/APPD S.S.1.2000
59	CHD/APPD S.S.1.2000	53	CHD/APPD S.S.1.2000
60	CHD/APPD S.S.1.2000	54	CHD/APPD S.S.1.2000
61	CHD/APPD S.S.1.2000	55	CHD/APPD S.S.1.2000
62	CHD/APPD S.S.1.2000	56	CHD/APPD S.S.1.2000
63	CHD/APPD S.S.1.2000	57	CHD/APPD S.S.1.2000
64	CHD/APPD S.S.1.2000	58	CHD/APPD S.S.1.2000
65	CHD/APPD S.S.1.2000	59	CHD/APPD S.S.1.2000
66	CHD/APPD S.S.1.2000	60	CHD/APPD S.S.1.2000
67	CHD/APPD S.S.1.2000	61	CHD/APPD S.S.1.2000
68	CHD/APPD S.S.1.2000	62	CHD/APPD S.S.1.2000
69	CHD/APPD S.S.1.2000	63	CHD/APPD S.S.1.2000
70	CHD/APPD S.S.1.2000	64	CHD/APPD S.S.1.2000
71	CHD/APPD S.S.1.2000	65	CHD/APPD S.S.1.2000
72	CHD/APPD S.S.1.2000	66	CHD/APPD S.S.1.2000
73	CHD/APPD S.S.1.2000	67	CHD/APPD S.S.1.2000
74	CHD/APPD S.S.1.2000	68	CHD/APPD S.S.1.2000
75	CHD/APPD S.S.1.2000	69	CHD/APPD S.S.1.2000
76	CHD/APPD S.S.1.2000	70	CHD/APPD S.S.1.2000
77	CHD/APPD S.S.1.2000	71	CHD/APPD S.S.1.2000
78	CHD/APPD S.S.1.2000	72	CHD/APPD S.S.1.2000
79	CHD/APPD S.S.1.2000	73	CHD/APPD S.S.1.2000
80	CHD/APPD S.S.1.2000	74	CHD/APPD S.S.1.2000
81	CHD/APPD S.S.1.2000	75	CHD/APPD S.S.1.2000
82	CHD/APPD S.S.1.2000	76	CHD/APPD S.S.1.2000
83	CHD/APPD S.S.1.2000	77	CHD/APPD S.S.1.2000
84	CHD/APPD S.S.1.2000	78	CHD/APPD S.S.1.2000
85	CHD/APPD S.S.1.2000	79	CHD/APPD S.S.1.2000
86	CHD/APPD S.S.1.2000	80	CHD/APPD S.S.1.2000
87	CHD/APPD S.S.1.2000	81	CHD/APPD S.S.1.2000
88	CHD/APPD S.S.1.2000	82	CHD/APPD S.S.1.2000
89	CHD/APPD S.S.1.2000	83	CHD/APPD S.S.1.2000
90	CHD/APPD S.S.1.2000	84	CHD/APPD S.S.1.2000
91	CHD/APPD S.S.1.2000	85	CHD/APPD S.S.1.2000
92	CHD/APPD S.S.1.2000	86	CHD/APPD S.S.1.2000
93	CHD/APPD S.S.1.2000	87	CHD/APPD S.S.1.2000
94	CHD/APPD S.S.1.2000	88	CHD/APPD S.S.1.2000
95	CHD/APPD S.S.1.2000	89	CHD/APPD S.S.1.2000
96	CHD/APPD S.S.1.2000	90	CHD/APPD S.S.1.2000
97	CHD/APPD S.S.1.2000	91	CHD/APPD S.S.1.2000
98	CHD/APPD S.S.1.2000	92	CHD/APPD S.S.1.2000
99	CHD/APPD S.S.1.2000	93	CHD/APPD S.S.1.2000
100	CHD/APPD S.S.1.2000	94	CHD/APPD S.S.1.2000

CASE, ASSY - COMPR
DRAWING NO. 0-351-02-67001
SHT. No. 3

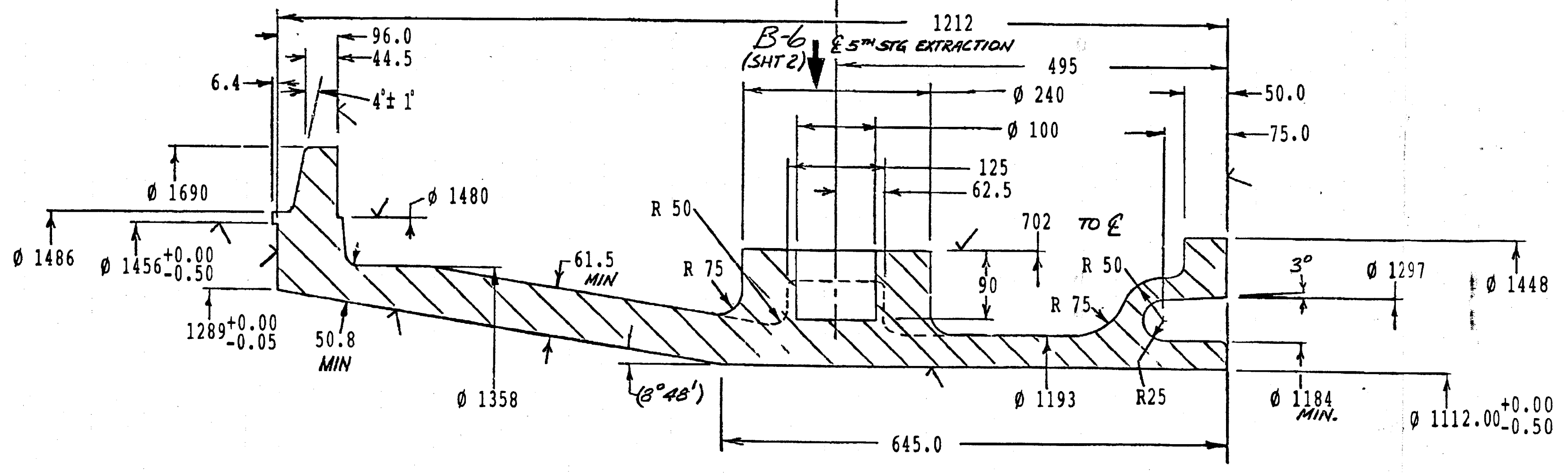

- NOTES:
- 1. UNLESS OTHERWISE SPECIFIED, ALL CAST RADII TO BE R20 & ALL CAST EDGES TO BE R6.
 - 2. INSPECT CASING PER ITEM 3.
 - 3. PAINT CASING PER AA0674102.
 - 4. PREPARE SURFACES FOR PAINTING PER AA0674101.
 - 5. TORQUE BOLTS AIR TIGHT PER ITEM 5.
 - 6. BLEND EXTRACTION GROOVES TO SMOOTH CONTOUR BY REMOVING ALL HIGH AREAS OR CAST PROJECTIONS. BLEND AREA ADJACENT TO HORIZ JOINT APPROX 75 mm PER SIDE TO 1:3.
 - 7. APPLIED KGC IDENTIFICATION, SEE COMPLEMENTARY DOCUMENT NO. 8.

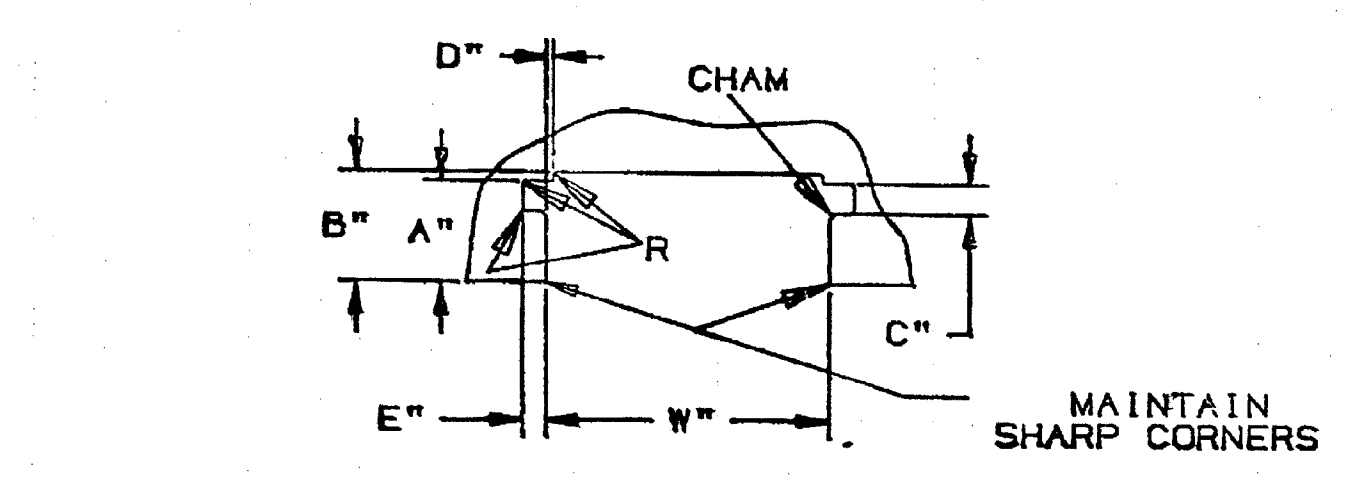
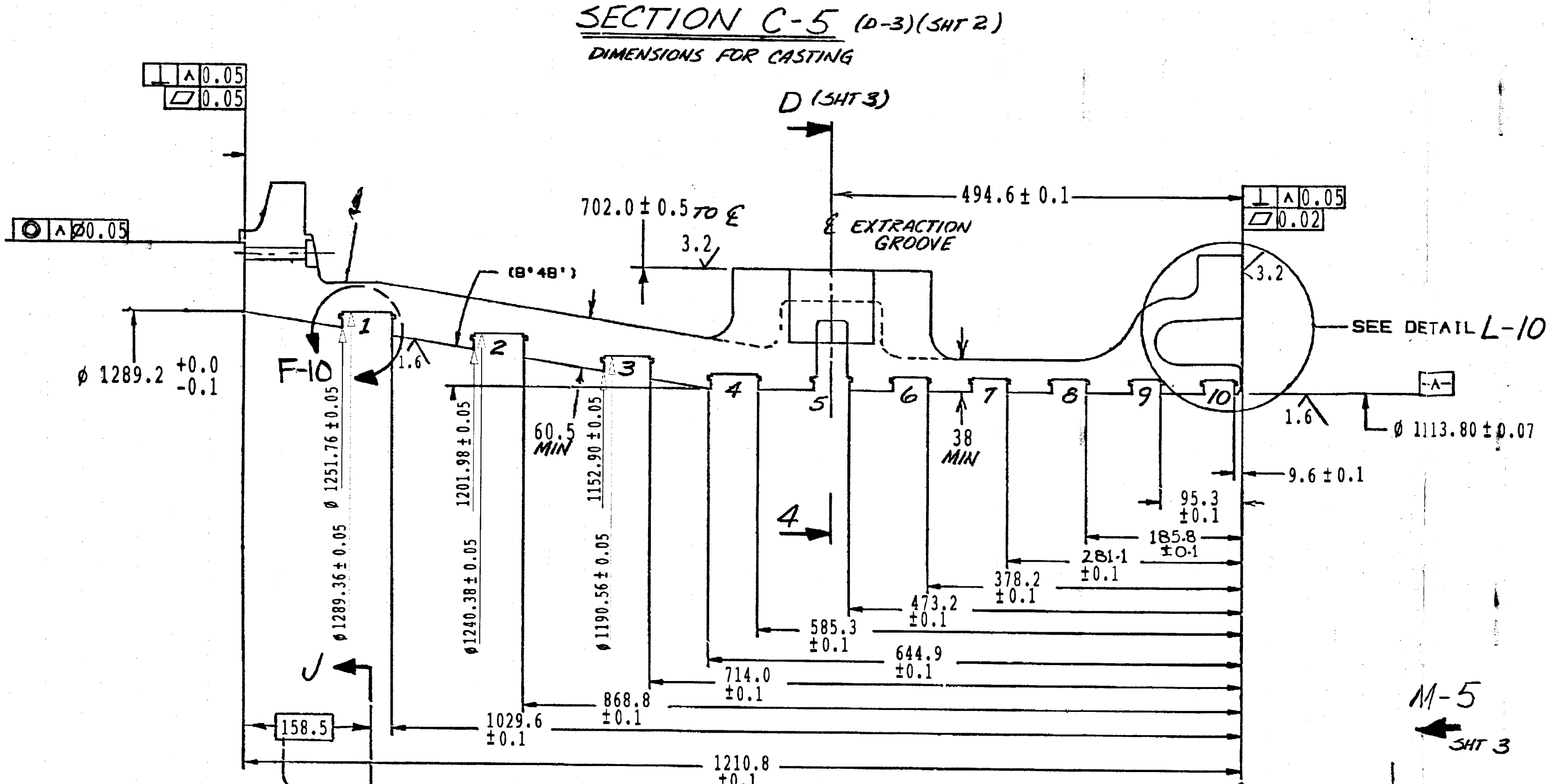

STG	A ± 0.05	B ± 0.1	C ± 0.05	D ± 0.5	E ± 0.2	F ± 0.05	G ± 0.1	CHAM
*1	15.85	18.8	4.45	1.0	3.6	60.86	0.5	0.8 ± 0.1
*2	16.20	19.2				60.86		X 45°
*3	15.82	18.8				57.15		
*4	15.24	18.2				57.15		
5 & 7 & 8	15.11	16.6				42.85		
9 & 10	15.11	16.6				34.21		

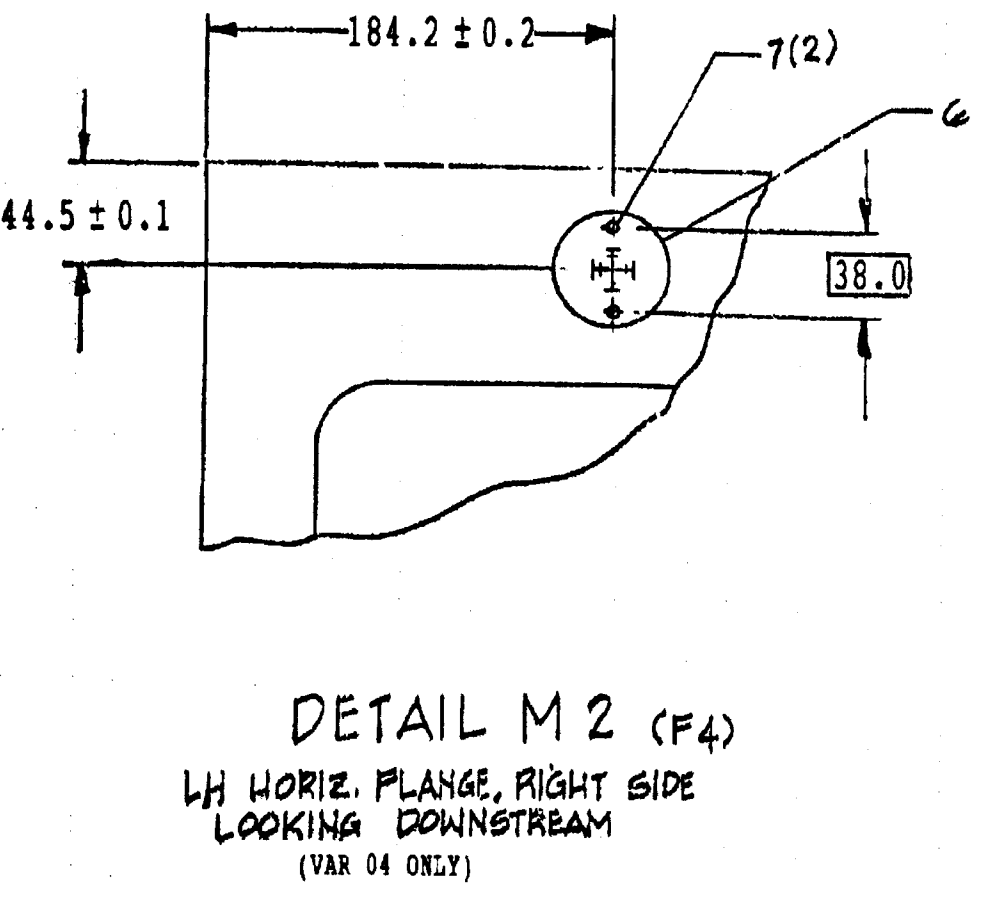
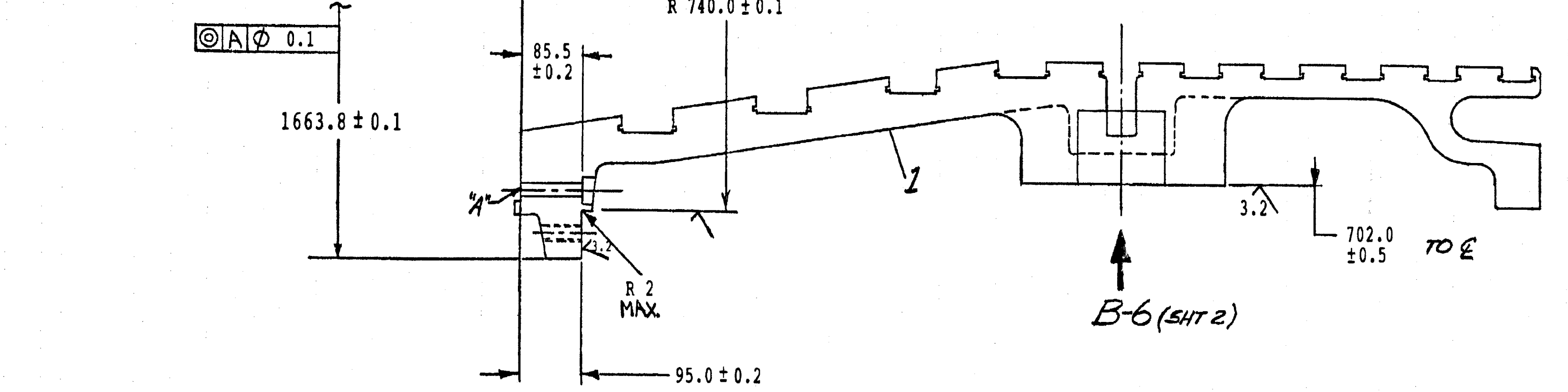
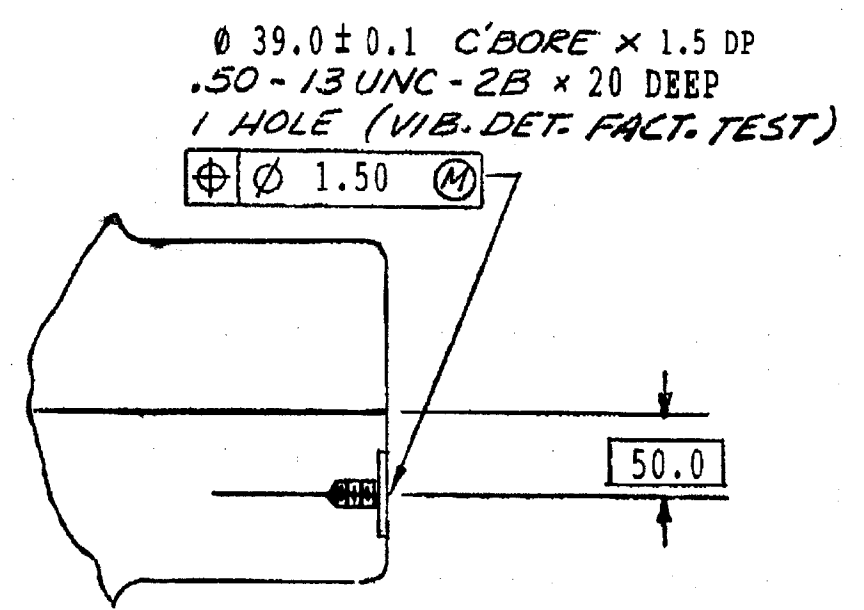
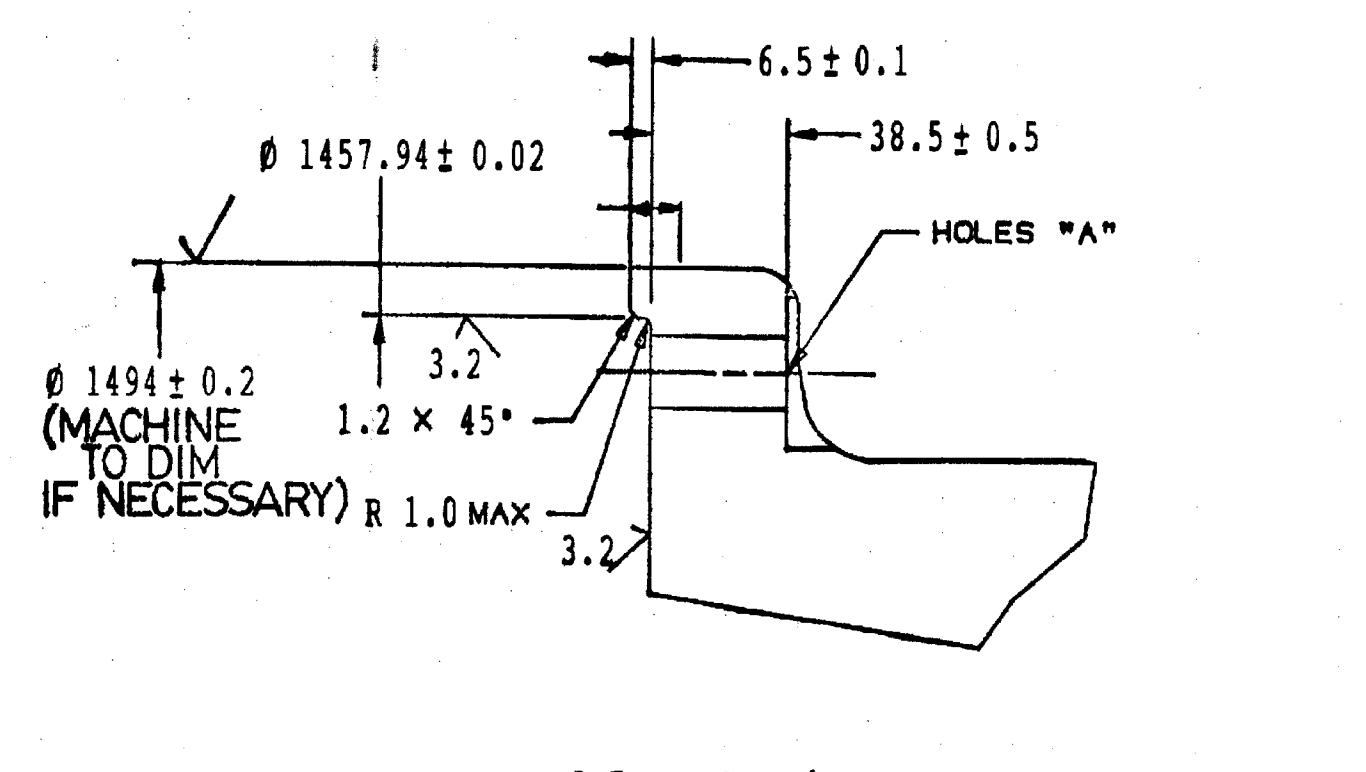
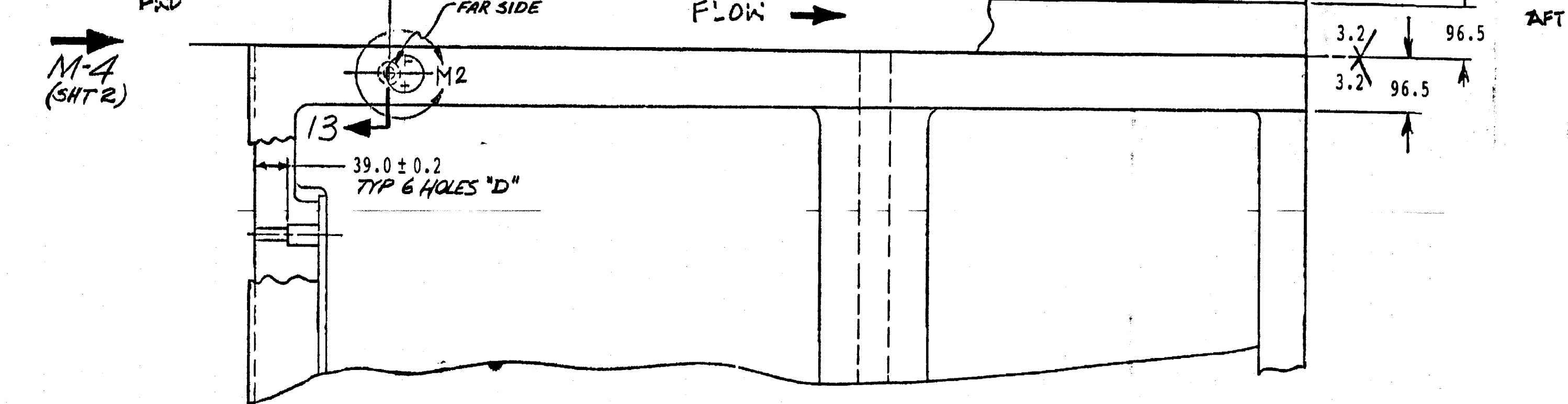
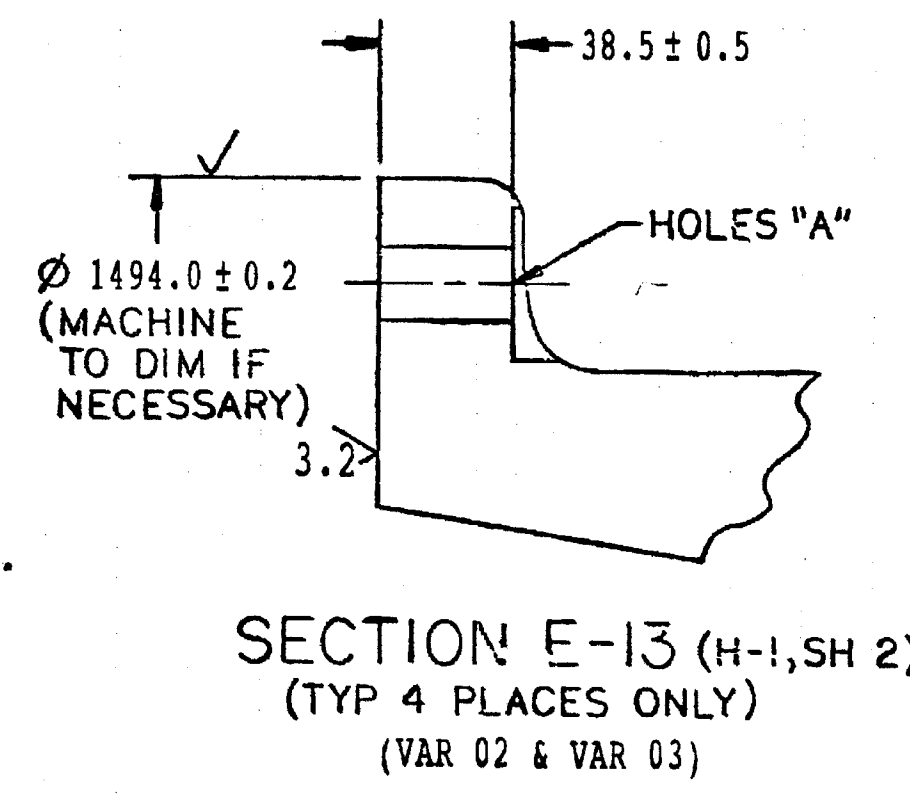

VAR NO	DESCRIPTION	MATERIAL	GE REF
06 (CAST)	AS SHOWN	HY19774 (B50A684)	G2
05 (CAST)	AS SHOWN	AA19702 (B2A1B3)	G1
04 (MACH)	APPLY DETAIL M2 (F4 SH-1) ONSA VAR 01.	AA19702 (B2A1B3)	G3
03 (MACH)	DIFF MATL/PATTERN ONSA VAR 02.	HY19774 (B50A684)	G6
02 (MACH)	OMIT SECTION H-10 (H-1, SH2) & DETAIL M2. APPLY SECTION E-13 (H-1, SH2) ONSA VAR 01.	AA19702 (B2A1B3)	G5
01 (MACH)	AS SHOWN EXCEPT OMIT SECTION E-13 (H-1, SH2) & DETAIL M2, APPLY SECTION H-10 (H-1, SH-2)	AA19702 (B2A1B3)	G4

REV	DATE	ALTERED	CHD/APPD	REV	DATE	ALTERED	CHD/APPD	REV	DATE	ALTERED	CHD/APPD	REV	DATE	ALTERED	CHD/APPD	REV	DATE	ALTERED	CHD/APPD	REV	DATE	ALTERED	CHD/APPD	REV	DATE	ALTERED	CHD/APPD	REV	DATE	ALTERED	CHD/APPD	REV	DATE	ALTERED	CHD/APPD
8		KGC		7		PROCESS		6		PAINT		5		TORQUING		4		SURFACE PREP		3		INSPECTION		2		BROCESS		1		APPLIED PRACTICES		IT		DESCRIPTION	

TYPE OF PRODUCT OR NAME OF CUSTOMER/PROJECT		GAS TURBINE FR-6B	
DEPT	UNTL. DIMS.	SCALE	WEIGHT (KGS)
423	4/11	NTS	1800
TITLE	CASE, ASSY - COMPR	DRAWING NO	0-351-02-67001
REV	NO. OF ITEMS	NO. OF SHTS	NO. OF VAR.
06	NA	3	NA

THE INFORMATION ON THIS DOCUMENT IS THE PROPERTY OF BHARATI HEAVY ELECTRICALS LIMITED. IT MUST NOT BE USED DIRECTLY OR INDIRECTLY IN ANY WAY DETRIMENTAL TO THE INTEREST OF THE COMPANY.
 GENERAL DIMENSIONAL LIMITS, FITS & TOLERANCES AS PER HY02.30261