



PRODUCT STANDARD
STEAM TURBINE ENGINEERING

ST 39012

PAGE 1 OF 3-2

Ⓢ BASED ON OWN EXPERIENCE

TECHNICAL SPECIFICATION FOR CONTROL FLUID PUMPING SET

1.0 INTENT OF SPECIFICATION :

This specification is intended to cover design, manufacture, assembly, testing and supply of control fluid pump complete with foundation base plate, anchor bolts, lifting lugs, coupling and other accessories including motor, to the power station at which BHEL supplies the equipment.

The pumping sets are intended for operation in conjunction with steam turbines and should be suitable for continuous operation at an average ambient temperature of 50°C and 90% humidity. However, during start up fluid temperature may go as low as 20°C. Therefore the motor shall be capable of starting and continuous running of the pumping set at this

Ⓢ value of temperature i.e. 20°C, meeting the requirements of operating Point I of Control Fluid Pump Data Sheet Under PGMA 11924 of corresponding Project.

2.0 FUNCTION:
Control fluid pumping set feeds control fluid to the governing system of Steam Turbine during start up and continuous operation of the set. Two pumping sets are envisaged for each turbine. One pump is kept as standby pump.

3.0 GENERAL INFORMATION :

COPYRIGHT AND CONFIDENTIAL
The information on this document is the property of BHARAT HEAVY ELECTRICALS LIMITED. It must not be used directly or indirectly in any way detrimental to the interest of the company.

TLV 50198
TLV 7004

SIGN & DATE	AGREED:	NAME	SIGN. & DATE
<i>Q</i> 29/3/84	T.A/S TE	D. BANERJEE	<i>Q</i> 29/3/84
	TSX	V. K. SINGH	<i>Q</i> 29/3/84
	QAX	S.S. CHAUHAN	<i>Q</i> 29/3/84
	DEPTT	NAME	SIGN. & DATE

INVENTORY NO. P. 5510	Revision : 01	Distribution	Qty.	Approved :	ST
	Date : 9/1/88			<i>Q</i> ENGG. DEV. MANAGER	8-20
		Prepared	Issued	Date	
		<i>Q</i>	STE (TG)	6.3.84	
			HARDWAR		



PRODUCT STANDARD

ST 39012

STEAM TURBINE ENGINEERING

PAGE 2 OF 321

SIGN & DATE

SUPERSEDES
INVENTORY No.

COPYRIGHT AND CONFIDENTIAL
 The information on this document is the property of BHARAT HEAVY ELECTRICALS LIMITED.
 It must not be used directly or indirectly in any way detrimental to the interest of the company.

SIGN & DATE

INVENTORY No.

P-5570

REV-01

3.1 PUMP MOUNTING DETAILS

The pump shall be vertically mounted on the control fluid tank. The pump base plate shall match the counter flange provided on the tank as shown in annexure-I, OR AS PER THE SKETCH FURNISHED BY BHEL ALONG WITH ENQUIRY/ORDER CONFIRMATION FOR THE SAME IS TO BE GIVEN BY THE SUPPLIER.

3.2 FLUID SPECIFICATIONS

The fluid to be handled by the pump is a fire resistant fluid. The relevant properties of the fluid are as mentioned in Annexure-II.

4.0 PUMP TYPE & RATING :4.1 PUMP TYPE

The control fluid pump shall be of vertical, multistage, centrifugal type suitable for pumping control fluid. The control fluid pump shall combine a low pressure and a high pressure pump on a single shaft. Each pump shall have its own discharge flow/pressure characteristics. The total fluid flow needed for the low pressure and high pressure circuits flows through the low pressure pump and a pressure is built up according to the discharge flow/pressure curve of this part of the pump. After this stage, a part of the low pressure fluid is extracted and the remaining fluid flows through the high pressure pump where the pressure increases according to the discharge flow/pressure curve of the high pressure pump. The final discharge pressure from high pressure pump is addition of the pressures generated in the two pump sections.

4.2 PUMP RATING

The pump is required to operate normally at three duty points. The characteristics of both the pumps (low pressure and high pressure pumps) of Control fluid pump at



PRODUCT STANDARD
STEAM TURBINE ENGINEERING

ST 39012

PAGE 3 OF 32

31

the working fluid temperature of 55°C shall be as per the data sheet attached with the enquiry /order. The same are to be confirmed by the supplier at the time of submitting their offer.

Contd....

COPYRIGHT AND CONFIDENTIAL

The information on this document is the property of Bharat Heavy Electricals Ltd. It must not be used directly or indirectly in any way detrimental to the interest of the company

INVENTORY NO. P-5510
SIGN & DATE 14-11-94

SUPERSEDES OLD TRACING BY NEW TRACING
UNDER THE SAME NO.
CHANGE ADVICE NO. STE-94-405.
NAME R.C.A. SIGN *DeS* DATE 16-10-94

REVISION 01

WORKED BY	उमेश कुमार हजरेमा	<i>अश</i>	21.10.94
CHECKED BY	राजेश अग्रवाल	21.10.94	31.10.94



PRODUCT STANDARD

STEAM TURBINE ENGINEERING

ST 39012

PAGE 4 OF 32

SIGN & DATE

SUPERSEDES
INVENTORY No.

COPYRIGHT AND CONFIDENTIAL
The information on this document is the property of BHARAT HEAVY ELECTRICALS LIMITED.
It must not be used directly or indirectly in any way detrimental to the interest of the company.

SIGN & DATE

INVENTORY No.

P-5570

REV-01

5.0 MOTOR :

A suitable motor conforming to the pump requirement shall be supplied. The motor shall also meet other requirements as mentioned in Annexure-III.

6.0 DESIGN AND CONSTRUCTION OF PUMP :

- 6.1 All materials used in the construction of the pumps shall be selected from the range of materials most appropriately suitable for the purpose & service conditions. The bidder shall furnish along with bid the material specification for all the components to BHEL for their review and acceptance by BHEL/owner. BHEL/owner reserves the right to ask for changes in material. The size shall be standardised wherever possible so as to ensure interchangeability.
- 6.2 The materials of construction of the pumps shall be such as to resist corrosion and erosion and shall give a long trouble free service.
- 6.3 The lubrication of the pump bearing and gear coupling shall be arranged through a tapped connection on pump casing itself as shown in Annexure-I.
- 6.4 The design shall be such as to keep the friction loss and wear caused by end thrust, wear in mechanical seals and bearings and cavitation to the minimum. It should ensure long and trouble free service. All the rotating parts of the pump shall be balanced dynamically in assembled condition. The permissible level of vibration shall be according to VDI 2056 or ^{equivalent} The noise level should not be more than 85 dba when measured at a distance of 1.5 m above floor and 1.0 m horizontally from equipment base plate.



PRODUCT STANDARD
STEAM TURBINE ENGINEERING

ST 39012

PAGE 5 OF 32

SIGN & DATE

SUPERSEDES
INVENTORY NO.

COPYRIGHT AND CONFIDENTIAL
The information on this document is the property of BHARAT HEAVY ELECTRICALS LIMITED. It must not be used directly or indirectly in any way detrimental to the interest of the company.

SIGN & DATE

INVENTORY NO.

P. 55/10

REV-01

- 6.5 The pump bore and casing shall be capable of withstanding hydrostatic test pressure in line with para ~~9.2.4.~~ 10.3.2 (e) [Ⓟ]
- 6.6 Seals must comply with the following properties :
- a) Easy access and amenability for maintenance work.
 - b) No contamination of the medium from material abraded from the seals.
 - c) Minimum leakage losses with their controlled removal.
 - d) The material of seals should be resistant to fire resistant fluid (see Annexure-II - for properties of fire resistant fluid).
- 6.7 At suitable points on the components, erection eyes or lifting hooks shall be fitted for transport and erection. Their locations must be shown on the dimensional drawings.
- 6.8 Suitable thrust bearings shall be provided in the pumping set to take the thrust load of the pump & motor. The bearings shall be designed so as to assure 30,000 hours of continuous service.
- 6.9 The mechanical design shall allow easy access to parts for maintenance work to be carried out.
- 6.10 Both the discharge branches of the pump shall be taken out above the base plate by the supplier.
- 6.11 The pumps shall be provided with drainage and venting devices.
- 6.12 All system parts conveying fluid shall be of fluid resistant construction.
- 6.13 Compression type fittings are not permissible.
- 6.14 For pump running at subcritical speeds, it shall be ensured ^{minimum 15%} that the critical speed lies above the maximum speed attainable during operation. For pump running at



PRODUCT STANDARD

STEAM TURBINE ENGINEERING

ST 39012

PAGE 6 OF 32

31

SIGN & DATE

SUPERSEDES
INVENTORY No.

COPYRIGHT AND CONFIDENTIAL

The information on this document is the property of BHARAT HEAVY ELECTRICALS LIMITED. It must not be used directly or indirectly in any way detrimental to the interest of the company.

SIGN & DATE

INVENTORY No.

P. 5510

REV-01

supercritical speeds, it shall be demonstrated that there is a difference of sufficient magnitude (not less than 15%), between the operating speed and the bordering critical speeds.

6.15 NAME PLATE BILINGUAL [Ⓢ]

Name plate identification marking shall be as follows in hindi as well as in English languages.

- Type/Designation
- Manufacturer's name
- Manufacturer's works no.
- Year of manufacturing
- Purchase order no.
- High Pressure pump -
 - Volumetric flow(Litres/min.)
 - Discharge pressure(Bar/MWC)
- Low Pressure pump -
 - Volumetric flow (Litres/min.)
 - Discharge pressure(Bar/MWC).
- Operating Temp.(°C)
 - Max.
 - Min.
- Flow Medium
- Speed

7.0 COUPLING :

A suitable gear coupling shall be provided for coupling pump with motor and shall be designed to facilitate easy alignment and long trouble free service.

8.0 BASE PLATE, ANCHOR BOLTS, NUTS ETC. :

Necessary base plate, anchor bolts, nuts, sleeves and inserts shall be supplied by the supplier.



PRODUCT STANDARD
STEAM TURBINE ENGINEERING

ST 39012

PAGE 7 OF 32

31

SIGN & DATE

SUPERSEDES
INVENTORY No.

COPYRIGHT AND CONFIDENTIAL
The information on this document is the property of BHARAT HEAVY ELECTRICALS LIMITED.
It must not be used directly or indirectly in any way detrimental to the interest of the company.

SIGN & DATE

INVENTORY No.

REV-01

9.0 CLEANING, PAINTING, CONSERVATION & PACKING

The surface shall be cleaned & prepared for the application of the coatings by blasting with non-silicatic abrasive agents. The protective coating shall be fluid resistant to prevent contamination of fluid specified & to prevent the deterioration of the coating itself. The supplier shall give exact and precise details about the measures envisaged by him for surface protection, which shall be checked & approved by BHEL.

After testing the pump, its internals shall be thoroughly cleaned, dried and conserved before packing it. The pump shall be suitably packed for transportation. It should be packed such that it is safe at least for 2 years in a very damp and saline atmosphere.

Instructions should be issued regarding deconservation, reconservation and storage of package.

10.0 QUALITY ASSURANCE, INSPECTION & TESTING.

- a) The manufacturer shall conduct all the tests required to ensure that all the component parts of the control Fluid Pump offered conform to the requirements of the specification and Q&A in compliance with requirements of applicable codes and standards.
- b) The bidder shall submit alongwith his offer, quality plan in the enclosed format.



PRODUCT STANDARD
STEAM TURBINE ENGINEERING

ST 39012

PAGE 8 OF 32

31

SIGN & DATE

SUPERSEDES
INVENTORY No.

COPYRIGHT AND CONFIDENTIAL

The information on this document is the property of BHARAT HEAVY ELECTRICALS LIMITED.
It must not be used directly or indirectly in any way detrimental to the interest of the company.

SIGN & DATE

INVENTORY No.

P-5576

REV-01

- 10.1 The particulars of the proposed shop tests and procedures for the test shall be submitted to BHEL/its customer for approval along with quality plan.
- 10.2 The material shall be despatched only after inspection and clearance of material by BHEL/its customer and approval of test certificates by BHEL/its customer.
- 10.3 An indicative programme of minimum tests and checks to be carried out on the control fluid pump as envisaged by BHEL are given below. This is however not intended to form a comprehensive testing programme as it is supplier's responsibility to prepare detailed quality plan, which should also include tests, checks carried out by supplier as a part of their normal practice. The Quality Plan is subject to the approval of BHEL/its customer and BHEL/its customer reserves the right to ask for any more checks at the time of quality plan finalisation. BHEL/its customer shall indicate customer hold points in approved Quality Plan beyond which work shall not proceed without the approval of BHEL. The supplier shall furnish his production plan and scheduled dates of testing atleast 3 months in advance to enable BHEL/its customer to plan for witnessing the tests, identified as customer hold points.



PRODUCT STANDARD
STEAM TURBINE ENGINEERING

ST 39012

PAGE 9 OF 32

34

SIGN & DATE	SIGN & DATE
SUPERSEDES INVENTORY No.	INVENTORY No.
COPYRIGHT AND CONFIDENTIAL The information on this document is the property of BHARAT HEAVY ELECTRICALS LIMITED. It must not be used directly or indirectly in any way detrimental to the interest of the company.	

10.3.1 Testing of materials -The material of each component shall be tested as per relevant specification for its chemical composition & mechanical properties viz, Y.S., UTS, Impact, % elongation, % R.A. etc. Suitable NDT to ensure freedom from surface and subsurface defects shall be carried out.

10.3.2 Following tests shall be carried out during various stages of manufacture at manufacturer's Works :

- a) Check for dimensions of all the component parts including surface finish, axial & radial runout of shaft etc.
- b) All the component parts of the pump shall be subjected to visual examination.
- c) Impeller shaft and casing shall be subjected to MPE/DPT to ensure freedom from harmful surface defects. Shaft shall be subjected to UT examination to ensure freedom from harmful internal defects.
- d) Complete rotor shall be subjected to dynamic balancing as per ISO - 1940 or equivalent.
- e) Casing shall be subjected to hydraulic test at 1.5 times the design pressure.
- f) All the welding shall be carried out as per qualified procedures and welders as per ASME section IX. All the welding in rotating and load carrying parts shall be subjected to

REV-01



PRODUCT STANDARD

STEAM TURBINE ENGINEERING

ST 39012

PAGE 10 OF 32

SIGN & DATE

SUPERSEDES
INVENTORY No.

COPYRIGHT AND CONFIDENTIAL

The information on this document is the property of BHARAT HEAVY ELECTRICALS LIMITED. It must not be used directly or indirectly in any way detrimental to the interest of the company.

SIGN & DATE

INVENTORY No.

REV-01

to RT and DPT to ensure freedom from harmful internal and surface defects. Other weldments shall be subjected to DPT/MPI.

- g) Pump shall be subjected to performance test as per DIN 1944 or ^(b) equivalent. During performance test noise and vibration level shall be measured. Performance test shall be carried out with contract motor.
- h) Alignment checks for pump shaft and coupling to motor-shaft-and-coupling shall be carried out.
- i) Strip down examination after performance test shall be carried out and during strip down examination visual examination for wear ring clearance check, radial clearance and axial play of shaft, dimension/fitment of bearing housing, check for trueness of coupling and alignment shall be carried out.
- j) Type and routine test of motor as per IS: 325-1978. ^(c)
In addition to this degree of protection and noise level shall be carried out as type test and vibration measurement as routine test as per relevant IS.
- k) Check for completeness after reassembly shall be carried out.
- l) Check for painting and conservation shall be carried out.

11.0 SPECIAL TOOLS & TACKLES

One set of tools required for erection, operation and maintenance of the pumping sets shall be supplied together with each pump. List of these tools shall be



PRODUCT STANDARD
STEAM TURBINE ENGINEERING

ST 39012

PAGE 11 OF 32

SIGN & DATE

SUPERSEDES
INVENTORY No.

COPYRIGHT AND CONFIDENTIAL

The information on this document is the property of BHARAT HEAVY ELECTRICALS LIMITED. It must not be used directly or indirectly in any way detrimental to the interest of the company.

SIGN & DATE

INVENTORY No.

P-5510

REV-01

submitted alongwith the offer.

12.0 SPARES :

The tenderer shall quote item wise price of the recommended spares for both pump & motor for three years and five years of operation respectively.

13.0 GUARANTEE :

13.1 The supplier shall guarantee trouble free and satisfactory operation of the equipment for a period of 18 months after the installation and commissioning or for a period of 36 months from the day the equipment is received by purchaser whichever occurs earlier.

13.2 The supplier shall guarantee the capacity, head and efficiency of the pump as per the tested characteristics with the control fluid.

13.3 If during erection and commissioning at site and operation during guarantee period, any deficiency in a part is detected, BHEL site representative shall prepare the assessment report and a copy of the same shall be forwarded to the supplier. The supplier shall replace/rectify the concerned items free of charge. The supplier, if he so desires, may depute his representatives to site at his own cost otherwise the findings of BHEL shall be final and binding on the supplier of pumping set.

13.4 The supplier shall repair/replace the defective parts at his own cost during the guarantee period.

14.0 DOCUMENTS REQUIRED WITH THE TENDER PROPOSAL :

Following documents shall be supplied by the tenderer with his tender proposal. In the absence of any of which, the offer may not



PRODUCT STANDARD
STEAM TURBINE ENGINEERING

ST 39012

PAGE 12 OF 32

37

SIGN & DATE

SUPERSEDES
INVENTORY No.

COPYRIGHT AND CONFIDENTIAL
The information on this document is the property of BHARAT HEAVY ELECTRICALS LIMITED. It must not be used directly or indirectly in any way detrimental to the interest of the company.

SIGN & DATE

INVENTORY No.

P-5570

REV-01

be considered.

Examination of the pre-approval documents by BHEL shall not release the manufacturer and his sub-contractors, of their responsibilities. The approval documents shall form the basis for the order. No further changes shall be made without approval from BHEL.

- 14.1 Certified performance curves of both the pumps & control fluid pump (viz. Low pressure pump and high pressure pumps) at working fluid temperature of 20°C and 55°C.
- Discharge vs head
 - Discharge vs power input
 - Discharge vs efficiency
 - Speed vs torque
- 14.2 Cross sectional assembly drawing of the pump with the bill of material.
- 14.3 Pump, motor assembly drawing giving important dimensions, base plate details, suction & discharge nozzle details, details of lubrication arrangement, lifting lugs/ eye bolts locations, mounting arrangement showing static and dynamic loading.
- 14.4 Data required as per enclosed blank data sheet (Annexure-VI).
- 14.5 Quality plan in the enclosed format along with all the reference documents, inhouse ^{test} procedures etc. during the manufacture of the
- 14.6 Technical literature on the pumping set - Pumping set. under offer. The technical literature shall particularly include detailed description, Assembly and dismantling instructions and instructions for erection, operation, cleaning and maintenance of the pumping set.
- 14.7 Technical details/data of motor offered in line with Annexure-III. Detailed filled



PRODUCT STANDARD
STEAM TURBINE ENGINEERING

ST 39012

PAGE 13 OF 32

SIGN & DATE

SUPERSEDES
INVENTORY NO.

COPYRIGHT AND CONFIDENTIAL

The information on this document is the property of BHARAT HEAVY ELECTRICALS LIMITED. It must not be used directly or indirectly in any way detrimental to the interest of the company.

SIGN & DATE

INVENTORY NO.

P-5510

REV-01

up data sheets as per Annexure-IV shall be furnished after placement of the order.

15.0 DOCUMENTS TO BE SUPPLIED AFTER THE PLACEMENT OF ORDER :

Unless otherwise specified 15 copies and one reproducible each of the following documents duly approved by BHEL shall be furnished by the supplier within 12 weeks after the award of contract. BHEL's Customer name shall be indicated on the drawing/documents as per the instructions given in the Purchase Order.

- 15.1 General arrangement drawing, in line with para ^{14.3} 15.3 above.
- 15.2 Cross sectional assembly drawing, with complete bill of materials.
- 15.3 Motor data as per enclosed format(Annexure IV).
- 15.4 Spare part list for both pump and motor.
- 15.5 Gear coupling details.
- 15.6 List of tools and tackles.
- 15.7 The static and dynamic loading details on support/foundation.
- 15.8 Operating instructions.
- 15.9 Cleaning and maintenance instructions
- 15.10 Assembly and dismantling instructions.
- 15.11 Instructions on deconservation and reconservations.
- 15.12 Model packing list.



PRODUCT STANDARD
STEAM TURBINE ENGINEERING

ST 39012

PAGE 14 OF 32

31

SIGN & DATE

SUPERSEDES
INVENTORY No.

COPYRIGHT AND CONFIDENTIAL

The information on this document is the property of BHARAT HEAVY ELECTRICALS LIMITED. It must not be used directly or indirectly in any way detrimental to the interest of the company.

SIGN & DATE

INVENTORY No.

P-55/10

REV-01

16.0 CERTIFICATES

Unless otherwise specified fifteen copies of following certificates in english language for each pumping set shall be supplied before the despatch of the equipment. The despatch clearance shall be given only after the approval of test certificates as is indicated 10.20 above.

16.1 Material test certificate for tests conducted as per clause 10.3.1 above ^{for} the main component parts such as impeller, casing, shaft, casing bolts, wear rings, pressure pipes, tooth type gear coupling, bearing supports, stuffing box, packing, mechanical seal etc.

16.2 Hydraulic test certificate.

16.3 Performance test reports and curves. Noise and vibration level report.

16.4 Type and routine reports of motor.

16.5 For all other tests/checks as is indicated in Quality Plan and is carried out by bidder as his usual practice.

16.6 Shipping documents.

16.7 Guarantee certificates: Approval of test certificates by BHEL/its customer shall not relieve bidder of his responsibility and guarantee of satisfactory performance for the stipulated period.

17.0 MISCELLANEOUS

The tenderer can make suitable offer even if there are minor deviations which do not affect the efficient functioning of the equipment. However, the deviations must be clearly spelled out in the offer, which can be incorporated in supply if duly approved by BHEL/Owner.

Failure to do so shall render the supplier responsible for all consequences in the event of placement of an order.

INVENTORY No.
P-5510

SIGN & DATE

SUPERSEDES
INVENTORY No.

COPYRIGHT AND CONFIDENTIAL
The information on this document is the property of BHARAT HEAVY ELECTRICALS LIMITED. It must not be used directly or indirectly in any way detrimental to the interest of the company.

REV. No.
383/153716

SIGN & DATE

INVENTORY No.
P-5510



PRODUCT STANDARD
STEAM TURBINE ENGINEERING

FORM
ST 39012
PAGE 15 OF 35

ANNEXURE I
PAGE 1 OF 3

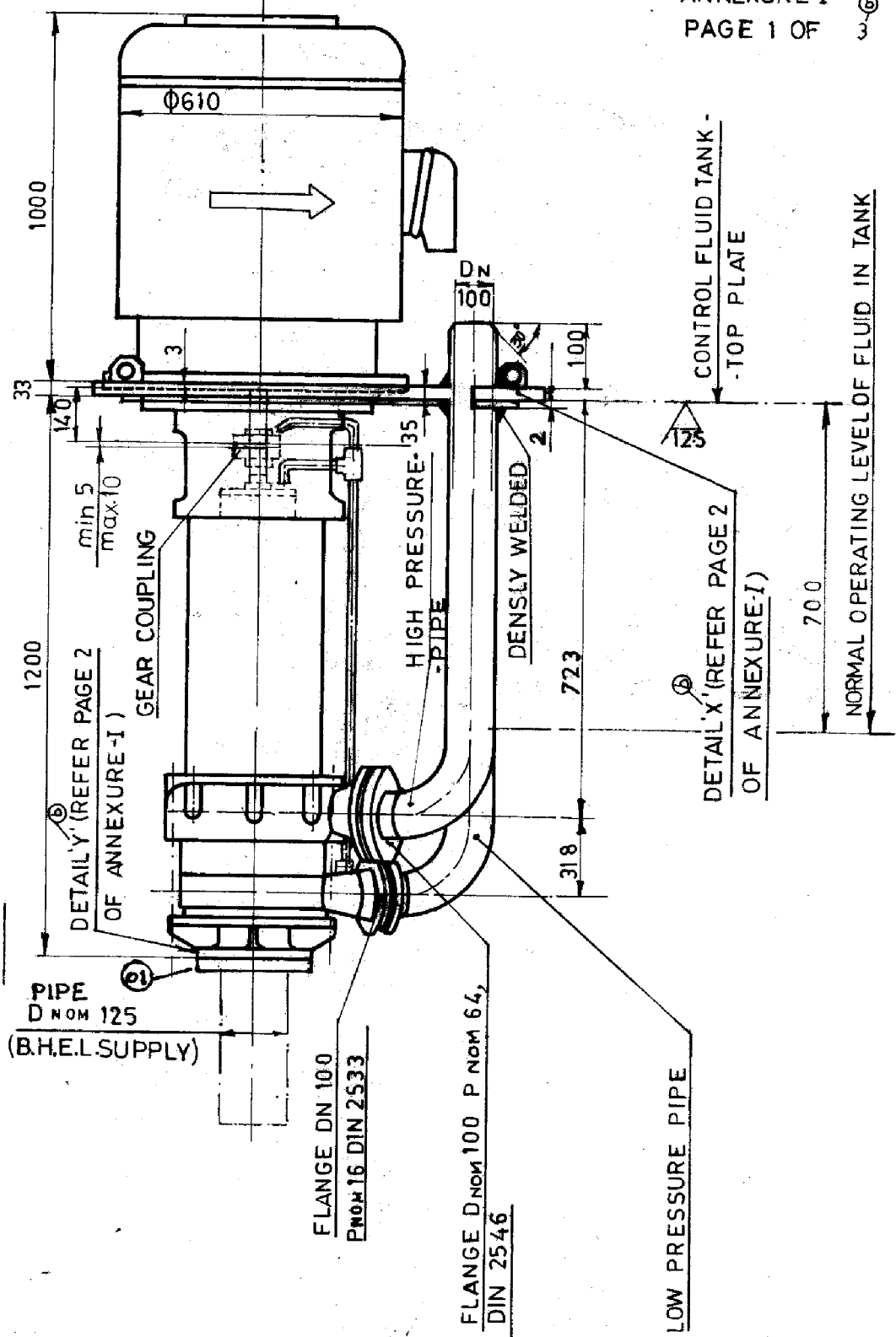

REV-01



PRODUCT STANDARD
STEAM TURBINE ENGINEERING

ST 39012

PAGE 16 OF 32

ANNEXUR I
PAGE 2 OF 3

SIGN & DATE

SUPERSEDES
INVENTORY No.

COPYRIGHT AND CONFIDENTIAL

The information on this document is the property of BHARAT HEAVY ELECTRICALS LIMITED. It must not be used directly or indirectly in any way detrimental to the interest of the company.

DRG NO.
383/153716

SIGN & DATE

INVENTORY No.
P. 5510

REV-01

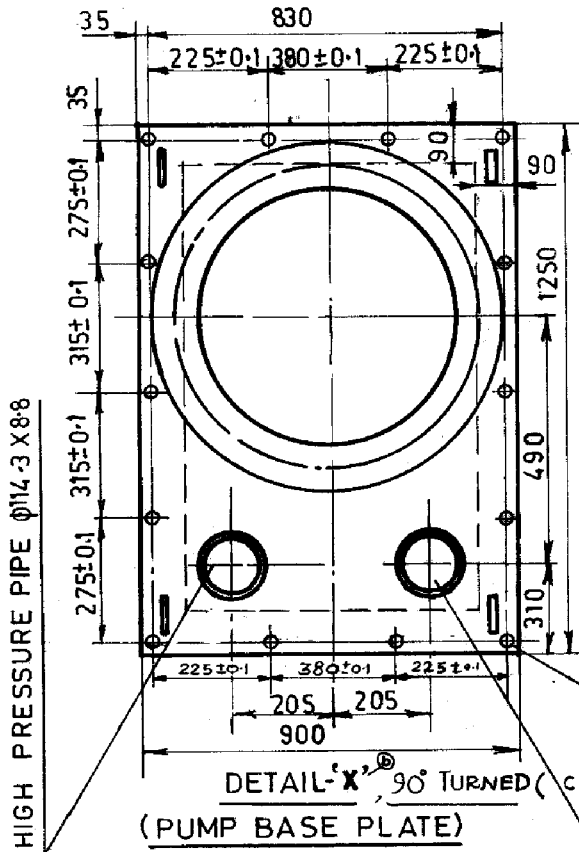

NOTE :-

ANY DEVIATION FROM THE DIMENSIONS MENTIONED ON BOTH PAGES OF ANNEXURE-I SHOULD BE CLEARLY SPELLED OUT BY THE SUPPLIER AT THE TIME OF OFFER.

VAR 00

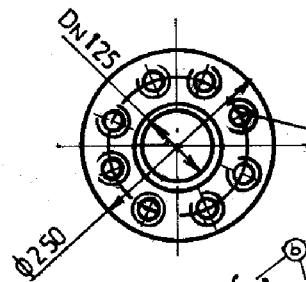

DETAIL-Y, VAR 00
(FLANGE DIN 2533 PN16)

8 HOLES M16 ON PCD 210

REMARK - APPLICABLE ONLY FOR SINGRAULI, KORBA, & RAMAGUNDAM 500 MW TG SETS. FOR FUTURE SETS. REFER NEW SHEET 17

AGREED By STE(TL) - *JmSivka* 7-3-84



PRODUCT STANDARD
STEAM TURBINE ENGINEERING

ST 39012

PAGE 17 OF 3234

SIGN & DATE

SUPERSEDES
INVENTORY No.

ANNEXUR I
PAGE 3 OF 3

COPYRIGHT AND CONFIDENTIAL
The information on this document is the property of BHARAT HEAVY ELECTRICALS LIMITED.
It must not be used directly or indirectly in any way detrimental to the interest of the company.

REF. No.
DRG. No.
4-11925-
75101

SIGN & DATE

7.1.87

INVENTORY No.

P-5510

REV-01

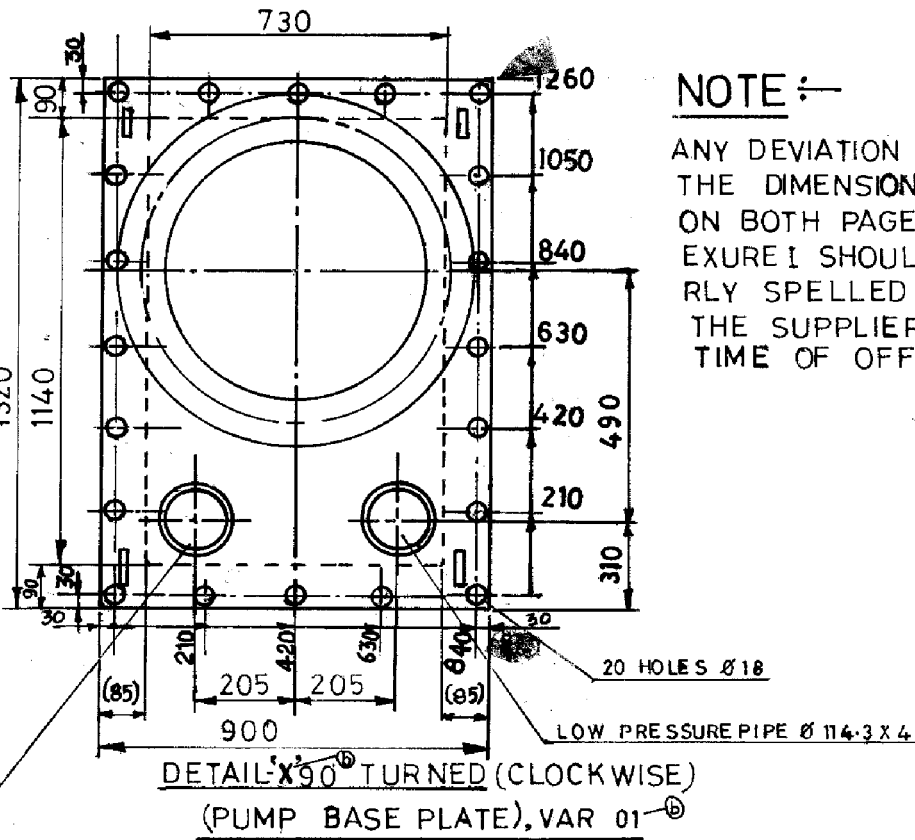

NOTE :-

ANY DEVIATION FROM THE DIMENSIONS MENTIONED ON BOTH PAGES OF ANNEXURE I SHOULD BE CLEARLY SPELLED OUT BY THE SUPPLIER AT THE TIME OF OFFER.

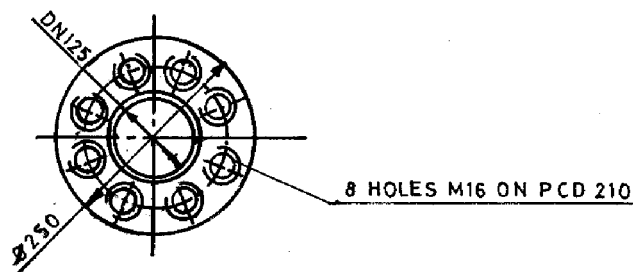

DETAIL 'Y', VAR 00
(FLANGE DIN 2533 PN16)

AGREED BY S.T.E.(T.L.) - 7.1.87



PRODUCT STANDARD
STEAM TURBINE ENGINEERING

ST 390 12

PAGE 18 OF 34 32

31

ANNEXURE -II

WORKING FLUID SPECIFICATION

Working fluid is a fire resistant fluid, consisting of phosphate esters of HS-D group, containing little water and Chlorine. Properties of the fire resistant fluid shall be as detailed below:

1. KINEMATIC VISCOSITY

at 55°C	21 mm ² /sec.
at 40°C) (Min) - 33 mm ² /sec.) (Max.) - 48 mm ² /sec.
at 20°C) (Min) - 115 mm ² /sec.) (Max.) - 210 mm ² /sec.

2. DENSITY

at 55°C	- 1.11 gm/cm ³
at 20°C	- 1.136 gm/cm ³

- | | |
|--------------------------------------|-----------------------|
| 3. Flash point | 235°C Min. |
| 4. Autoignition point | 500°C Min |
| 5. Pour Point | -18°C |
| 6. Water content | Max. 0.1% (By weight) |
| 7. Neutralisation No. | Max. 0.1 mg KOH/gm |
| 8. Chlorine content | 50 PPM (Max.) |
| 9. Air release property at 50°C | 5 minutes (Max.) |
| 10. Filtration class as per SAE A-6D | Class 6 |

COPYRIGHT AND CONFIDENTIAL

The information on this document is the property of BHARAT HEAVY ELECTRICALS LIMITED. It must not be used directly or indirectly in any way detrimental to the interest of the company.

SIGN & DATE

SUPERSEDES INVENTORY No.

SIGN & DATE

INVENTORY No.

P. 55/10

REV-01



PRODUCT STANDARD
STEAM TURBINE ENGINEERING

ST 39012

PAGE 19 OF 323

MOTOR - REQUIREMENTS

Annexure III

Page 1 OF 4

- 1.0 A suitable motor conforming to the pump requirements shall be supplied. The motor shall also meet the following requirements broadly. The motor shall conform to IS: 4722, IS: 325, IS: 2253, IS: 2254, IS: 4029 and IS: 3202, or equivalent BS: specifications. The motor shall match the requirements of the driven equipment in all respects. The motor shall meet all Indian statutory requirements.

2.0 APPLICATION

To drive control fluid pump for supplying fluid to the governing elements.

3.0 TYPE OF MOTOR

Squirrel cage, induction motor.

- 3.1 KW rating of the motor should be the maximum of the following three conditions:

3.1.1 It shall have atleast 15% reserve capacity than required to drive the pump when it is discharging maximum quantity at a viscosity corresponding to 50°C temperature.

3.1.2 It shall have at least 5 % reserve capacity than required to drive the pump when it is discharging maximum quantity at a viscosity corresponding to 35°C temperature.

3.1.3 It shall have at least 5 % reserve capacity than required to drive the pump when it is discharging 70% of maximum quantity at a viscosity corresponding to 20°C Temperature. Finally supplier shall furnish the KW rating at an ambient temperature of 50°C.

- 3.2 KW actually required by driven equipment under specified operation/startup conditions. : Pump capacity.

- 3.3 Rated Voltage : 415 V

Frequency : 50 Hz

SIGN & DATE

SUPERSEDES
INVENTORY No.

COPYRIGHT AND CONFIDENTIAL

The information on this document is the property of BHARAT HEAVY ELECTRICALS LIMITED. It must not be used directly or indirectly in any way detrimental to the interest of the company.

SIGN & DATE

INVENTORY No.

P-5510

20/1/85

Ahu

REV-01

STE (TA)



PRODUCT STANDARD
STEAM TURBINE ENGINEERING

ST 30012

PAGE 20 OF 3234

Annexure III

Page 2 OF 4

SIGN & DATE

SUPERSEDES
INVENTORY No.

COPYRIGHT AND CONFIDENTIAL
The information on this document is the property of BHARAT HEAVY ELECTRICALS LIMITED,
it must not be used directly or indirectly in any way detrimental to the interest of the company.

SIGN & DATE

INVENTORY No.

- 3.4 Permissible voltage and frequency variation under normal running condition. : $\pm 10\%$ Volt.
: $\pm 5\%$ frequency
- 3.5 Combined variation : 10 % (SUM OF ABSOLUTE VALUES)
- 3.6 Min. voltage required under starting conditions to bring driven equipment up to rated speed. : 80% rated
- 3.7 No. of phases : 3 \emptyset
- 3.8 Type of duty : Continuous
- 3.9 Full load speed : It shall be commensurate with pump speed as per design.
- 3.10 Full load current : As per design
- 3.11 Starting current : Not to exceed 600% of I rated. (Subject to IS tolerance)
- 3.12 Starting torque : 1.3 (Min) of rated torque.
- 3.13 Break down torque : 2.05 times (min) of rated value.
- 3.14 Efficiency at full load : 90 % (Min)
- 3.15 Power factor at full load : 0.85 (Min)
- 3.16 Motor shall be designed to withstand the voltage and torque stresses developed due to the difference between the motor residual voltage and incoming supply voltage equal to 150% of the rated motor voltage during fast changeover of buses.
- 4.0 STARTING DATA
- 4.1 Starting : Suitable for DOL starting
- 4.2 Acceleration time with full load connected. : 3.5 \pm 0.5 Secs.
Min. locked rotor with-stand time under hot conditions at highest voltage: 2.5 sec. more than starting time.
- 4.3 Permissible starting duty cycle, No. of starts. : 3 Starts equally spread over an hour & 2 consecutive starts from hot condition without any injurious heating to the winding.

REV-01



PRODUCT STANDARD
STEAM TURBINE ENGINEERING

ST 30012

PAGE 21 OF 32-34

Annexure III
Page 3 OF 4

SIGN & DATE

SUPERSEDES
INVENTORY No.

COPYRIGHT AND CONFIDENTIAL

The information on this document is the property of BHARAT HEAVY ELECTRICALS LIMITED. It must not be used directly or indirectly in any way detrimental to the interest of the company.

SIGN & DATE

INVENTORY No.

- 4.4 Overload (% of full load): Motor shall be capable of running at full load at 80% of rated voltage for five minutes and 70% of rated voltage for 1 sec. that can be carried by motor without impairing over-all performance and period for which this overload is applicable.
- 4.5 Location : Indoor
- 4.6 Class of Insulation : Class - F, Fungus resistant, Tropicalised as per IS: 3202, with temp. rise limited to 70°C over ambient of 50°C.
- 4.7 Shaft disposition and mounting : Vertical / flange mounted
- 4.8 Method of connections driven equipment. : Flange flexible coupling
- 4.9 Direction of rotation and corresponding terminal designation. : To suit pump
- 4.10 Enclosure and ventilation: Totally enclosed, fan cooled, IP-55
- 4.11 Bearing : Thrust bearing, minimum standard life not less than 30000 working hrs
- 4.12 Grounding device : Suitable arrangement shall be provided for earthing the motor at two separate and distinct connection points. Design of earthing conductor shall be as per IS: 4722-1992.
- 4.13 Terminal connectors for stator leads type and No. : 6, Neutral shall be connected externally in the terminal box.
- 4.14 Terminal box : To be provided with double compression gland for aluminium cable.
- 4.15 Whether phases segregated : No
- 4.16 Space heater : To be provided
- 4.17 Rated voltage : 240 Volts
- 4.18 Motor shall be provided with paint suitable for the working conditions. (Material, thickness, colour as specified.)
- 4.19 Following tests shall be carried out:
- Type and routine tests as per IS: 4722.
- Following additional tests shall also be carried out:

REV-01



PRODUCT STANDARD

STEAM TURBINE ENGINEERING

ST 39012

PAGE 22 OF 3234

Annexure III

Page 4 OF 4

SIGN & DATE

SUPERSEDES
INVENTORY No.

COPYRIGHT AND CONFIDENTIAL
The information on this document is the property of BHARAT HEAVY ELECTRICALS LIMITED. It must not be used directly or indirectly in any way detrimental to the interest of the company.

SIGN & DATE

INVENTORY No.

REV-01

(1) TYPE TESTS

- (a) Measurement of Noise Level as per IS 12065. ^(f)
- (b) Degree of protection test to conform to the specified degree of protection.

(11) ROUTINE TESTS

- (a) 20% overspeed test for 2 minutes.
- (b) Measurement of vibrations. as per IS 12075. ^(f)

5.0 SPECIAL REQUIREMENTS

- 5.1 Separate terminal box and space heaters shall be provided. The motor shall be suitable to operate in an environment of oil fumes.
- 5.2 The motor shall be rewoundable.
- 5.3 The motor shall have on line greasing facility.
- 5.4 The motor construction shall be suitable for easy disassembly and reassembly.
- 5.5 The terminal box shall be suitable for top and bottom entry of cables and shall be suitable for PVC insulated, PVC sheathed armoured aluminium cables. It shall be capable of being rotated through 180° in steps of 90°. It shall be able to withstand a fault level of 45 KA for 0.12 sec, degree of protection IP-55. ^(f)
- 6.0 Documents :

^(f) Motor data sheets and documents as per Annexure - IV shall be furnished with the offer. Final data sheet & documents shall be subject to BHEL approval after placement of purchase order.

PRODUCT STANDARD

STEAM TURBINE ENGINEERING

ST 30012

PAGE 29 OF 32

ANNEXURE - IV ³¹
SHEET 01 OF 04



DATA SHEET FOR AC-MOTOR

SIGN & DATE

INVENTORY NO.

COPYRIGHT AND CONFIDENTIAL
The information on this document is the property of BHARAT HEAVY ELECTRICALS LIMITED.
It must not be used directly or indirectly in any way detrimental to the interest of the company.

1. GENERAL

- i) Vendor document no. and revision no./date :
- ii) Project :
- iii) Customer :
- iv) BHEL- P.O. no. and date :
- v) Manufacturer :
- vi) Equipment driven by motor :
- vii) Motor type :

2. DESIGN AND PERFORMANCE DATA

- i) Frame size :
- ii) Type of duty :
- iii) Type of enclosure :
- iv) Type of cooling (IC) :
- v) Applicable standard to which motor conforms :
- vi) Enclosure degree of protection (IP) :
- vii) Type of mounting :
- viii) Direction of rotation as viewed from non-driving end :
- ix) KW rating at 50°C of ambient temp. :
- x) Rated voltage (volts) :
- xi) Rated frequency (Hz) :

INVENTORY NO. SIGN/DATE

P-5510
1.5.01

REV-01
①

SUPERSEDES OLD SHEET
UNDER C/A NO. STG/01/03

WORKED BY	SCV	1.5.01
CHECKED BY	V. KUMAR	1.5.01



PRODUCT STANDARD
STEAM TURBINE ENGINEERING

ST 39012

PAGE 26 OF 32

ANNEXURE - IV
SHEET 02 OF 04

37

SIGN & DATE

INVENTORY NO.

COPYRIGHT AND CONFIDENTIAL
The information on this document is the property of BHARAT HEAVY ELECTRICALS LIMITED.
It must not be used directly or indirectly in any way detrimental to the interest of the company.

SIGN & DATE

INVENTORY NO.

P-55/10 17/5/01

- xii) Permissible variation of:
 - a) Voltage (Volts) _____
 - b) Frequency (Hz) _____
 - c) Combind voltage and frequency (absolute value) _____
- xiii) Minimum permissible starting voltage (volts) _____
- xiv) Rated speed at rated voltage and frequency (RPM) _____
- xv) At rated voltage and frequency:
 - a. Full load current _____
 - b. No load current _____
- xvi) Power factor at :
 - a. 100% load _____
 - b. 75% load _____
- xvii) Efficiency at rated voltage and frequency at
 - a. 100% load _____
 - b. 75% load _____
- xviii) Starting current (Amps) at
 - a. 100% voltage _____
 - b. 80% voltage _____
- xix) Starting time at 100% and 80% of rated voltage _____
- xx) Safe stall time with 110% of rated voltage :
 - a. from hot condition _____
 - b. from cold condition _____
- xxi) Torques :
 - a. starting (Kg-metre) at 80% voltage _____
 - b. pull up (Kg-metre) _____
 - c. pull out (Kg-metre) _____
 - d. rated torque (Kg-metre) _____

REV-01
SUPERSEDES OLD SHEET UNDER C/A NO. STE/01/183

WORKED BY	SCV	1.5.01
CHECKED BY	V. KUMAR	1.5.01



PRODUCT STANDARD
STEAM TURBINE ENGINEERING

ST 39012

PAGE 25 OF 32

ANNEXURE - IV 37
SHEET 03 OF 04

SIGN & DATE

INVENTORY NO.

COPYRIGHT AND CONFIDENTIAL
The information on this document is the property of BHARAT HEAVY ELECTRICALS LIMITED.
It must not be used directly or indirectly in any way detrimental to the interest of the company.

INVENTORY NO. SIGN & DATE

P-5510 12/5/01

xxii) Stator winding resistance per phase (ohms) _____

xxiii) Flywheel moment (GD²) of motor (Kg-m²) _____

3. CONSTRUCTIONAL FEATURE :

i) STATOR WINDING INSULATION:

- a. Class _____
- b. Tropicalised (yes / no) _____
- c. Temperature rise over specified ambient of 50^oc, max 70^oc (yes / no) _____

d. Method of temp. measurement _____

e. Stator winding connection _____

f. Number of terminals brought out _____

ii) FOR SPACE HEATER:

- a. Type of terminal box and degree of protection _____
- b. No. of space heaters _____
- c. Location _____
- d. Rated voltage & power _____
- e. Double compression cable glands with lugs provided (yes / no) _____
- f. Suitable for cable size _____

iii) FOR MAIN TERMINAL BOX :

- a. Type of terminal box & degree of protection _____
- b. Double compression cable glands & lugs provided (yes / no) _____
- c. Suitable for cable size _____
- d. Terminal box capable of being rotated through 180^o in steps of 90^o (yes / no) _____
- e. Fault level (KA , sec.) _____

① REV-01

SUPERSEDES OLD SHEET UNDER C/A NO. STE/01/103

WORKED BY	SCV	1.5.01
CHECKED BY	V.KUMAR	1.5.01



PRODUCT STANDARD

STEAM TURBINE ENGINEERING

ST 39012

PAGE 26 OF 36

ANNEXURE - IV 3)
SHEET 04 OF 04

SIGN & DATE

INVENTORY NO.

COPYRIGHT AND CONFIDENTIAL
The information on this document is the property of BHARAT HEAVY ELECTRICALS LIMITED.
It must not be used directly or indirectly in any way detrimental to the interest of the company.

iv) BEARINGS :

- a. Type (at DE / NDE) _____
- b. Make _____
- c. Recommended lubricant _____
- d. Life _____

v) Starting suitable for :

- a. DOL only (yes / no) _____
- b. DOL as well as star-delta (yes / no) _____

vi) Total weight of motor (Kg):

4. i) Noise level :

ii) Vibration level :

iii) Paint materials, thickness, colour :

Note : Supplier / vendor shall get the confirmation about paint from BHEL before manufacturing of motor.

5. DOCUMENTS :

- i) Motor GA / dimensional drawings including terminal boxes drg.no. :- _____
- ii) CURVES AT RATED VOLTAGE :
 - a. Starting current -vs- time curve drg. no. :- _____
 - b. Speed -vs- starting time curve drg.no. :- _____
 - c. Torque -vs- speed curve drg.no. :- _____
 - d. Speed -vs- current curve drg.no. :- _____
 - e. Thermal withstand curve for hot and cold conditions. drg. no. :- _____

INVENTORY NO. SIGN & DATE

P-5510 7-15/01

Ⓣ REV-01

SUPERSEDES OLD SHEET UNDER C/A NO. 876/01/100

[Signature]

WORKED BY

ecv *[Signature]*

1.5.01

CHECKED BY

V. KUMAR *[Signature]*

1.5.01

INVENTORY No. P-5510	SIGN & DATE	COPYRIGHT AND CONFIDENTIAL The information on this document is the property of BHARAT HEAVY ELECTRICALS LIMITED. It must not be used directly or indirectly in any way detrimental to the interest of the company.	SUPERSEDES INVENTORY No.	SIGN & DATE
-------------------------	-------------	--	-----------------------------	-------------



PRODUCT STANDARD
STEAM TURBINE ENGINEERING

ST 30012
PAGE 1 OF 32

ANNEXURE-V
PAGE 1 OF 2

QUALITY CHECK PLAN

Sl. No.	Operation	Characteristics	Type of Check	Quantum of Check	Reference Document	Acceptance Norm	Format of Record	Agency
1	Material checking	Chemical composition and mechanical properties as per relevant standard.	Testing	100%				
2	Dimensional checking	Visual and dimensional check including fits and tolerances, axial and radial runout of rotors.	Measurement	100%				
3	N.D.T.	Check shaft and impeller for surface/subsurface defects.	N.D.T.	100%				
4	Balancing	Dynamic balancing of all rotating parts in assembled condition.	Measurement	100%				
5	Hyd. Test	Hydrostatic pressure test of casing.	Testing	100%				
6	-	Direction of rotation of pump.	Visual					
7	Performance Test	Performance test including noise and vibration level.	Testing	100%				
8	Strip down Test	Open the end cover without dismantling the impeller. Check	Visual & measurement	100%				

REV-01

QA Deptt : S.S. Chauhan *S.S. Chauhan*
7/3/84

INVENTORY No. <i>P. 5510</i>	SIGN & DATE	COPYRIGHT AND CONFIDENTIAL The information on this document is the property of BHARAT HEAVY ELECTRICALS LIMITED. It must not be used directly or indirectly in any way detrimental to the interest of the company.	SUPERSEDES INVENTORY No.	SIGN & DATE
---------------------------------	-------------	---	--------------------------	-------------



PRODUCT STANDARD
STEAM TURBINE ENGINEERING

ST *39012*
PAGE 26 OF 32

ANNEXURE-V
PAGE 2 OF 2

QUALITY CHECK PLAN

Sl	Operation	Characteristics	Type of Check	Quantum of Check	Reference Document	Acceptance Norm	Format of Record	Agency
----	-----------	-----------------	---------------	------------------	--------------------	-----------------	------------------	--------

the condition of the bearings. After reassembly, check the mechanical clearance and axial play of the shaft.

9. Conservation and Packing Visual 100%

After testing of pump, all internal/external surfaces shall be thoroughly cleaned, dried and conserved. All metallic surfaces except bright parts exposed to weather shall be given a suitable priming coat and then two coats of approved paints.

Ensure packing of all items in water and dust proof packages. The packages shall be sufficiently strong to safe guard against any damage during transit.

10. Motor Type and routine tests as per relevant standards of Motor. Testings 100%

11. Certificates Completeness & correctness of test certificates as per purchase specification. Visual 100%

QA Deptt: *S. S. Chauhan* *W. Chaitan*
7.5.84

REV-01

SIGN & DATE

SIGN & DATE

INVENTORY No. P-5570

SUPERSEDES INVENTORY No.

COPYRIGHT AND CONFIDENTIAL
The information on this document is the property of BHARAT HEAVY ELECTRICALS LIMITED. It must not be used directly or indirectly in any way detrimental to the interest of the company.



PRODUCT STANDARD
STEAM TURBINE ENGINEERING

ST 39012
PAGE 29 OF 32

ANNEXURE-VI ³¹
PAGE 1 OF 3

DATA TO BE FURNISHED BY BIDDER ALONG WITH
BID FOR CONTROL FLUID PUMP

1.0 Equipment and Service offered.

Please state whether the following equipment service as specified in the data sheets are offered or not.

- 1.1 Pump as per specification Yes/No
- 1.2 Motor Yes/No
- 1.3 Necessary instruments, test connections. Yes/No
- 1.4 Base plate as per org. Yes/No
- 1.5 Companion flanges Yes/No
- 1.6 Spare parts Yes/No
- 1.7 Maintenance and special erection tools. Yes/No
- 1.8 Commissioning of the set Yes/No

2.0 Design and Performance

- 2.1 Rated capacity of each pump M³/hr.
- 2.2 Discharge head at rated capacity.
- 2.3 Maximum discharge
- 2.4 Minimum discharge pressure corresponding to maximum flow.
- 2.5 Shut off head
- 2.6 Performance guaranteed when installed as per given arrangement. Yes/No
- 2.7 Pump b.h.p./kw at rated capacity.
- 2.8 Max. allowable suction lift (for minimum NPSH required).
- 2.9 Efficiency.

High Pr. Pump Low Pr. Pump

- 2.10 Rated speed (s⁻¹)
- 2.11 Rated power requirement (kw)
- 2.12 Installed actual power (kw)



PRODUCT STANDARD
STEAM TURBINE ENGINEERING

ST 39012

PAGE 30 OF 39
ANNEXURE-VI 31
PAGE 2 OF 3

SIGN & DATE

SUPERSEDES
INVENTORY No.

COPYRIGHT AND CONFIDENTIAL
The information on this document is the property of BHARAT HEAVY ELECTRICALS LIMITED. It must not be used directly or indirectly in any way detrimental to the interest of the company.

SIGN & DATE

INVENTORY No.

P-5570

REV-01

- 3.0 Material of construction
(TO BE CORRELATED WITH CROSS SECTIONAL DRAWING) ⑥
- 3.1 Casing
- 3.2 a) Impeller ⑥
b) GUIDE WHEEL
- 3.3 Base plate
- 3.4 Wearing rings
- 3.5 Shaft
- 3.6 Stuffing box
- 3.7 Packing
- 3.8 Mechanical seal
- 4.0 Connection
- 4.1 Suction size
- 4.2 Discharge size
- 5.0 Drawings.
- 5.1 General arrangement and sectional drgs. enclosed with offer. Yes/No
- 6.0 Weight Schedule
- 6.1 Weight of pump
- 6.2 Weight of motor
- 6.3 Weight of pump with motor and base frame
- 7.0 Characteristic curves
- 7.1 CHARACTERISTIC OF TORQUE
- 7.2 7.1 Power consumption/ discharge pressure
- 7.3 7.2 Discharge quantity/ pressure a) LOW PRESSURE PUMP
b) HIGH PRESSURE PUMP
- 7.4 7.3 Discharge efficiency
- 7.5 MOMENT OF INERTIA
- 8.0 any deviation taken against specification Yes/No
- 9.0 Deviations taken as mentioned here.



**PRODUCT STANDARD
STEAM TURBINE ENGINEERING**

ST 39012

PAGE 31 OF 32/34

ANNEXURE - VI
PAGE 3 OF 3

SIGN & DATE

SUPERSEDES INVENTORY NO.

COPYRIGHT AND CONFIDENTIAL

The information on this document is the property of Bharat Heavy Electricals Ltd. It must not be used directly or indirectly in any way detrimental to the interest of the company

SIGN & DATE

INVENTORY NO.

P-5570
14/11/94

SUPERSEDES OLD TRACING PAGE 33 BY
NEW TRACING PAGE 34 UNDER THE SAME
DOCUMENT NO.
CHANGE ADVISE NO. STE-34-485.
DATE 27.10.94
NAME R.C.A. SIGN

- 10.0 Construction features
- 10.1 Type of pump
- 10.2 Number of stages
- 10.3 Type of impeller
- 10.4 Type of stuffing box sealing offered.
- 10.5 Type of coupling offered
(a) Make
(b) Type
- 10.6 Type of bearing and lubrication.
- 10.7 Impeller diameter (mm)
(a) First stage
(b) Second stage
- 10.8 Manufacturer
- 10.9 Design of temperature:
- 10.10 Self priming YES/NO
- 10.11 Number of Rotor Rows:
- 10.12 Assly. DIM (MM)
- 10.13 Plate for the tank:
- 10.14 Intermediate bearing YES/NO
- 10.15 Position of casing joint to shaft Axial /Radial
- 16 Coating
(a) Out side
(b) Inside
- 17 Rating Plate in english YES/NO

10 Lubrication

- (a) Type of Lubricant
- (b) Quantity
- (c) Interval of its use.

REVISION - 0/

WORKED BY	372 कुमर एलिया	27.10.94
CHECKED BY	राज-चं. 35 (वार्ड)	27.10.94

Drawing No. - 4 18101 B1 005		REV. NO.-01 DATE- 25.08.2012
APPLICATION : C.F. PUMPS FOR STEAM TURBINE ITEM : MOTORS (AC)		
<u>ADDENDUM TO ST39012:</u>		
<i>Following additional specifications shall be complied to:-</i>		
<ol style="list-style-type: none"> 1. In addition to clause no.-4.14 & 5.5 at page –21 & 22 of 32 (Annexure –III) of ST39012:- <ol style="list-style-type: none"> (a) Motor Terminal box- fault level shall be 50 KA (rms) 0.25 second for 415V- AC system. (b) Cable glands shall be Nickel-Chromium plated brass, heavy duty, double compression type, confirming to BS:6121 with lugs. (c) The sizes of cables for glands shall be 1x3Cx300 mm² (AL). 2. In addition to clause no.-4.11 at page – 21 of 32 (Annexure-III) of ST39012:- Motor bearing shall be selected to take care of the Vertical/Axial thrust of the motor. 3. Paint shade shall be Shade 275 of IS5, Opaline green. 4. Reports of type tests shall be those conducted within last five years and shall be furnished along with motor data sheets. 5. Motor noise level shall be limited so as to achieve the Pump-Motor set sound pressure level ≤ 85 dBA. Measurement shall be as per IS 12065. 6. Limits of mechanical vibrations severity shall be limited to vibration grade "R" (Reduced) as per IS:12075/Vibration grade-A as per IEC 60034-14. 7. Motor Bearings (DE & NDE) shall be Sealed type to avoid frequent Re-greasing. 8. Motor data sheets & other documents shall bear the "Document no." , "Revision no." . & "Date" and shall be subject to BHEL/customer approval. 9. Above additional requirements supersede the corresponding requirements of ST39012. 		
Sd/- (Nirbhay Kumar) Prepared & Checked by	Sd/- (Vinod Kumar) Approved by	

Drawing No. - 4 18101 C2 005		REV. NO.-01 DATE- 25.08.2012
APPLICATION : C.F. PUMPS FOR STEAM TURBINE ITEM : MOTORS (AC)		
<u>ADDENDUM TO ST39012:</u> <i>Following additional specifications shall be complied to:-</i>		
1. In addition to clause no.-4.14 at page –21 of 32 (Annexure –III) of ST39012:- (a) Motor Terminal box- fault level shall be 45 KA (rms) 1 second for 415V- AC system. (b) Cable glands shall be Nickel-Chromium plated brass, heavy duty, double compression type, confirming to BS:6121 with lugs. (c) The sizes of cables for glands are 1x3Cx300 mm ² (AL).		
2. In addition to cl.no.-4.11 at page – 21 of 32 (Annexure-III) of ST39012:- Motor bearing shall be selected to take care of the Vertical/Axial thrust of the motor and the bearing loading & selection criteria shall be furnished.		
3. Paint shade shall be as per " RAL 5012 (Blue) ".		
4. Motor should be efficiency class-I confirming to IS 12615.		
5. Limits of mechanical vibrations severity shall be limited to vibration grade "R" (Reduced) as per IS: 12075/Vibration grade-A as per IEC 60034-14.		
6. Motor Bearings(DE & NDE) shall be Sealed type to avoid frequent Re-greasing.		
7. Reports of type tests shall be those conducted within last five years.		
8. Motor data sheets & other documents shall bear the "Document no." , "Revision no." . & "Date" and shall be subject to BHEL/customer approval.		
9. Motor Terminal Box:- The spacing between gland plate & centre of terminal stud shall be as follows:-		
Motor MCR in KW	Minimum distance between centre of stud & Gland plate in mm.	
Upto 3 KW	As per Manufacturer's practice	
Above 3KW – upto 7KW	85 mm	
Above 7KW – upto 13KW	115 mm	
Above 13KW – upto 24KW	167 mm	
Above 24KW – upto 37KW	196 mm	
Above 37KW – upto 55KW	249 mm	
Above 55KW – upto 90KW	277 mm	
Above 90KW – upto 125KW	331 mm	
Above 125KW – upto 200KW	203 mm	
Sd/- (Nirbhay Kumar) Prepared & Checked by	Sd/- (Vinod Kumar) Approved by	

00091-42611-3
DRAWING No.

TABLE : -

1. LOW PRESSURE PUMP.		DISCHARGE PRESSURE AT THE EXTRACTION AFTER L.P. PUMP SECTION (bar)		DISCHARGE FLOW AT THE EXTRACTION AFTER L.P. PUMP SECTION (dm ³ /Sec)	
SL.NO.	OPERATING POINT	TOTAL FLOW THROUGH L.P. PUMP SECTION(dm ³ /Sec)			
01	I	7.60+6.16=13.76	11.5 (REFER NOTE-1)	7.60	
02	II	20.60+6.16=26.76	10.8	20.60	
03	III	7.60+16.16=23.76	10.0 	7.60	

2. HIGH PRESSURE PUMP.		DISCHARGE PRESSURE AT THE EXTRACTION AFTER H.P. PUMP SECTION (bar)		FINAL DISCHARGE PRESSURE AFTER H.P. PUMP SECTION (bar)	
SL.NO.	OPERATING POINT	DISCHARGE FLOW THROUGH H.P.PUMP SECTION(dm ³ /Sec)			
01	I	6.16	27	38.5	
02	II	6.16	27	37.8	
03	III	16.16	21	31.0 	

- TECHNICAL REQUIREMENTS: -**
- PUMP MOUNTING DETAILS: PUMP MOUNTING DETAILS AND PUMP BASE PLATE AS PER VAR. 01 OF DETAIL 'X' GIVEN AT PAGE 1&3 OF ANNEXURE-I (PAGE 15&17) OF ST 39012.
 - FLUID TO BE HANDLED
BY THE PUMP: FIRE RESISTANT FLUID. PROPERTIES OF FLUID AS PER ANNEXURE-II OF ST 39012.
 - PUMP CHARACTERISTICS : AS PER TABLE.
 - ALL OTHER TECHNICAL REQUIREMENTS OF CONTROL FLUID PUMP MOTOR SET NOT SPECIFIED HERE SHALL BE AS PER ST 39012.
 - ALL THE TECHNICAL DATA REQUIRED AS PER ST 39012 FOR THE OFFERED PUMP MOTOR SET SHALL BE FURNISHED BY THE SUPPLIER AT THE TIME OF SUBMISSION OF OFFER.

NOTE : - 1. SHUT OFF HEAD OF L.P. PUMP SHOULD NOT EXCEED A VALUE OF 13 BAR.

STEAM TURBINE

TYPE OF PRODUCT OR NAME OF CUSTOMER/PROJECT

 **BHARAT HEAVY ELECTRICALS LTD.**
RANIPUR, HARDWAR

DRN	NAME	SIGN	DATE	NO. OF VAR
U. VERMA		-sd-	20.05.06	
CHD VIKAS		-sd-	20.05.06	
Appd R.C.A.		-sd-	20.05.06	73 74

AGREED DEPT	NAME	SIGN	DATE	STATUS OF DRG

REV	DATE	ALTERED M.S.Bisht-sd- CHECKED V.Malhotra-sd-
01	27.05.06	

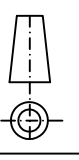
DEPT	STE	SCALE	WEIGHT (KG)	CARD CODE	DRAWING NO.
4011		N.T.S.	-		3-11924-16000

REF. TO ASSY. DRG.	ITEM No.	NO. OF ITEMS
-	-	75 77

31192425000
Ref.Drawing No>

Sign & Date

REV	DATE	ALTERED CHECKED

GRADE OF UNTOL. DIM
M/CG. AA0230208 mm
WELDING CLASS 'B' OF AA0621104
GAS CUTTING TABLE 3 OF AA0621104

CHANGES ARE INCORPORATED AS PER C/ADV. NO. STE-06-F0110

TITLE : CONTROL FLUID PUMP MOTOR SET.

SHEET No.	No. OF SHEETS
1	1

MASTER LIST OF DOCUMENTS (MDL) FOR CF PUMP

Sl. No.	Document	Remarks
<u>A. Documents to be submitted for BHEL approval prior to manufacturing:</u>		
1.	Datasheet of CF Pump	STE-TG
2.	Pump characteristics curves (HP & LP stages)	STE-TG
3.	Pump Cross-sectional drawing & Bill of material/Part list	STE-TG
4.	General Arrangement drawing of CF pump	STE-TG
5.	Datasheet of CF Pump motor	CIE
6.	Motor -GA drawing & Characteristics	CIE
7.	Motor Electrical Connection diagram	CIE
8.	Motor Type Test reports /Certificates	CIE

Notes:

1. The vendor to submit the documents within 3 weeks from the data of placement of purchase order.
2. While submitting the documents the vendor to clearly mention the exceptions w.r.t. the documents already approved earlier by BHEL.