



भारत हेवी इलेक्ट्रिकल्स लिमिटेड
BHARAT HEAVY ELECTRICALS LIMITED

पारेषण व्यापार अभियांत्रिकी प्रबंधन

TRANSMISSION BUSINESS ENGINEERING MANAGEMENT

COPYRIGHT AND CONFIDENTIALITY The information on this document is the property of BHARAT HEAVY ELECTRICALS LTD. It must not be used directly or indirectly in anyway detrimental to the interest of the company	प्रलेख संख्या DOC. No	TB-343-553-040-B	Rev. No.	02		बनाया/ Prepared	जांचा/ Checked	स्वीकृती/ Approved	
	TYPE/ प्रकार OF DOC.	TECHNICAL SPECIFICATION			हस्ता. / SIGN	-sd-	-sd-	-sd-	
	TITLE/ शीर्षक	AIR-CONDITIONING SYSTEM FOR RELAY CONTROL BUILDING			नाम / NAME	AR	VSK	RMS	
					दिनांक/ DATE	25/09/12	25/09/12	25/09/12	
					समूह/GROUP	TBEM	W.O. No	80014	
	ग्राहक/ CUSTOMER	POWERGRID CORPORATION OF INDIA LTD.							
	परियोजना/ PROJECT	±800KV, 6000MW, HVDC MULTI-TERMINAL NER/ER –NR/WR INTERCONNECTOR-I PROJECT							
	प्रपत्र संख्या/ CA NO.	C-61901R-S056-8/CA-II/3660 dated 22.12.2011 for on-shore Supplies and C-61901R-S056-8/CA-IV/3662 dated 22.12.2011 for Services							
	स्थान/ STATION	AGRA							
	विषय-सूचि/ CONTENTS								
अनुभाग / Section	विवरण / Description						पृष्ठ संख्या/ Page No		
1	Intent, Design criteria, System requirement and scope						1-7		
2	Equipment Specification						8-9		
3	Project details and general technical requirement						10-44		
4	Drawings & Annexure to Technical Spec						45-47		
	02	29.07.2013	AR	SKS	SS	Revised to exclude Air conditioning for UMD, Battery room & Valve control room. These are now part of package-A.			
	01	31.10.2012	-sd- AR	-sd- VSK	-sd- RMS	Revised in line with Powergrid's comments received vide letter ref. C/ENGG/HVDC/NER-NR/212/867 dtd. 23.10.12			
	Rev No.	Date	Altered	Checked	Approved	REVISION DETAILS			
	Distribution				To	TBEM	TBMM	TBQM	Vendor
					Copies	1	1	1	4



SECTION - 1

Intent, Design criteria, System Requirement and scope

1.1 INTENT OF SPECIFICATION

- a) This specification is intended to specify the requirements for design, engineering, manufacture, inspection & testing before supply, packing, forwarding, transportation to site, unloading, storage, complete erection of all equipment and accessories, testing of the system, trial run, commissioning of the system, final painting and carrying out acceptance test of **Air-Conditioning System** along with its accessories and auxiliary equipments / instruments etc. at **AGRA site** as mentioned in this section and in various other sections of this specification for **±800KV, 6000 MW HVDC Multi Terminal NER/ER-NR/WR Interconnector-I Project** for Power Grid Corporation of India Limited (POWERGRID).
- b) The Contract shall be on unit rate basis for the quantities furnished by BHEL. Variations (upward/downward) in quantities during contract stage shall be settled on the basis of unit rates furnished in the bid for actual consumption of material as certified by BHEL site.
- c) The Contract shall be on unit rate basis for the quantities furnished by BHEL. During contract stage, quantities of various items of BOQ may vary to any extent and same rates will be applicable so far the resultant variation in total contract value is within ±20%. Variations beyond ±20% shall be negotiated mutually.
- d) It is not the intent to specify herein all the details of design and manufacture. However, the equipment shall conform in all respect to high standards of design, engineering and workmanship and shall be capable of performing the required duties in a manner acceptable to Purchaser / Owner, who will interpret the meaning of drawings and specifications and shall be entitled to reject any work or material, which in his/their judgment is not in full accordance with the specifications.
- e) The bidder shall be deemed to have understood completely all the tender drawings and documents and quoted accordingly.
- f) In case of any deviation, the bidder shall indicate separately the deviations clause-wise with respect to the specification in the 'Schedule of Deviation' as per prescribed format. Deviations in any other form including clarifications / assumptions / etc will not be considered and it will be construed that the bid conforms strictly to the specification.
- g) The system / equipment shall be capable of performing the required duties as per the specification requirements.
- h) The term '**Owner**' appearing in this specification shall refer to **Power Grid Corporation of India Limited (POWERGRID)**, the term '**Purchaser**' shall refer to **Bharat Heavy Electricals Limited (BHEL)** and the term '**Contractor**' shall refer to the **successful Bidder**.



1.2 INTRODUCTION

Air-Conditioning system for areas of other buildings at AGRA converter station shall be provided to ensure satisfactory operation of the equipments of HVDC system under the range of climatic conditions to which the station may be subjected.

Buildings requiring environment control shall include 17 nos. Relay Control buildings.

1.3 DESIGN CRITERION

- a) All air conditioned Spaces shall be designed
 - To achieve an inside temperature of $24^{\circ}\text{C}\pm 1^{\circ}\text{C}$ (Dry Bulb).
- b) Outdoor conditions at **AGRA**, which shall be considered for design of above systems:

Sl. No.	Description	Temp. ($^{\circ}\text{C}$)
1	Maximum dry bulb one hour average	50
2	Maximum dry bulb 24 hour average	40
3	Annual mean dry bulb temperature	30
4	Minimum dry bulb one hour average	0
5	Maximum wet bulb one hour average	33
6	Dry bulb temperature for low ambient condition	33
7	Wet bulb temperature for low ambient condition	23

1.4 SYSTEM REQUIREMENT

Air-conditioning system shall be provided on continuous basis in the following areas:

1.4.1 RELAY CONTROL BUILDINGS/ ROOMS

There are in all 17 nos. standalone relay control rooms, situated at various locations in switchyard. 12 nos. of these rooms are having dimensions of 6x3.9mtrs. & 5 nos. are of 9x3.9mtrs. Each building shall be equipped with two separate physical units of 100% capacity (1 working+ 1 standby) air-cooled air-conditioning units.

Number & rating of the unit for each relay control building shall be as follows.

- i) Relay control building (6 x 3.9 meter): 2 nos. (1working+1stand by) of 3TR capacity each
- ii) Relay control building (9 x 3.9 meter): 2 nos. (1working+1stand by) of 3TR capacity each

1.4.1.1 System Description and Control Philosophy

The two units shall work in conjunction through a Microprocessor based controller for desired operation. The system shall be designed for 24hours, 365 days of the year operation to maintain the inside temperature of $24^{\circ}\text{C}\pm 1^{\circ}\text{C}$.

One of the air-conditioners shall be running at a time and on failure of the same or as described hereunder, the other unit shall start automatically. To ensure longer life of the system, the redun-



dant units shall also be running in cyclic operation through the controller. However, during running of one air-conditioning unit if the inside temperature of the building reaches to a predefined value (i.e. 35°C), the other unit shall also start to maintain the inside temperature less than 24°C and will give an alarm for such situation. After achieving this temperature, the other unit shall again shut off automatically.

1.5 INTERFACE REQUIREMENT

a) Air conditioning System

Controllers to be provided in each Relay building must have provision to receive signal from Purchaser's Fire detection and alarm (FDA) system for tripping off the Air Conditioning Units in case of fire. Fire fighting contractor shall provide NC contacts which will be wired to the controller for tripping the contactors for air-conditioning units by Air Conditioning contractor.

Provision of required potential free contacts has been made in FDA system, which shall be wired up by Air Conditioning contractor in his controller.

b) Air conditioning system shall be interfaced for control and monitoring of all the equipments through Purchaser's Building Management System (BMS). Following alarms/ annunciation shall be taken to BMS for which Air Conditioning Contractor shall make provision in his panel accordingly to be wired up by others:

- Run Status AC-1/ AC-2
- AC-1 Trip
- AC-2 Trip
- Temperature

1.6 POWER SUPPLY ARRANGEMENT

Air Conditioning units for relay control buildings shall be fed through the nearest BMK placed in AC Yard/ Relay building panel (Illumination system).

1.7 SCOPE

The scope of the work under the contract shall be deemed to include all such items, which although not specifically mentioned in the bid documents and/or in the bidder's proposal, but are required to make the equipment/ system complete for its safe, efficient, reliable and trouble free operation.



1.7.1 Scope of supply

- 1.7.1.1** The Bill of Quantities shall be read in conjunction with the Instructions to Bidders, General and Special Conditions of Contract, Technical Specifications, and Drawings.
- 1.7.1.2** The quantities given in the Bill of Quantities are estimated and provisional, and are given to provide a common basis for bidding. The basis of payment will be the actual quantities of work ordered and carried out, as measured by the Contractor and verified by the Purchaser and valued at the rates and prices bid in the priced Bill of Quantities.
- 1.7.1.3** A rate or price shall be entered against each item in the priced Bill of Quantities. The cost of Items against which the Contractor has failed to enter a rate or price shall be deemed to be covered by other rates and prices entered in the Bill of Quantities.
- 1.7.1.4** The whole cost of complying with the provisions of the Contract shall be included in the Items provided in the priced Bill of Quantities, and where no Items are provided, the cost shall be deemed to be distributed among the rates and prices entered for the related Items of Work.
- 1.7.1.5** General directions and descriptions of work and materials are not necessarily repeated nor summarized in the Bill of Quantities. References to the relevant sections of the Contract documentation shall be made before entering prices against each item in the priced Bill of Quantities.
- 1.7.1.6** Miscellaneous items like hardware, fixtures etc. shall be deemed to be included under the relevant BOQ items and bidders shall consider the same while quoting for BOQ items.

*Supplies for Air-Conditioning System at **AGRA** broadly consist of the following:*

Sl. No.	Item Description	Unit	Quantity
1.	Air conditioning Unit of 3TR capacity (As per description given under Cl. 1.4.1.1 & Cl. 2.2)	Nos.	34
2.	Microprocessor based Controller for 3TR ECU units (As per description given under Cl. 1.4.1.1 & Cl. 2.2)	Nos.	17

Besides, Bidder shall take a note of the following:

- Power & Control cables for system will be supplied on free issue basis to contractor. BHEL shall procure various sizes of cables for the complete requirement of sub-station and bidder shall consider cables accordingly for his system requirements. It may be noted that the necessary modifications shall be made by contractor for the termination of the cables in their equipments.*
- Bidder in his offer shall furnish the requirement of feeders i.e. number, type & rating for various systems. Purchaser will lay the main incomer to these areas, however termination of these cables in the respective panels shall be in contractor's scope. All cabling (laying & termination) further from these panels to various equipments and for control & interlocking of these equipments shall be in contractor's scope.*



-
- c. *Since laying & termination of all power & control cables is in contractor's scope, supply of cable accessories such as lugs, glands, cable tags & markers etc. shall be included by the bidders in their offers.*
 - d. *Necessary cable trays will be supplied on free issue basis to the contractor, however necessary hardware for fixing the same on walls or elsewhere shall be included by the bidders in their offers.*
 - e. *Earthing material viz. GS flat & wire will also be supplied on free issue basis to contractor; however requirement shall be given by the bidders in their respective bids.*
 - f. *Contractor shall submit valid Type test report for approval by owner. Fresh type test of equipment is not envisaged.*
 - g. *Valid Type Test reports (not more than 5 years old) for degree of protection of electrical panels shall be submitted by contractor for approval during contract stage. Type test need not be done specially. However, in case the type test reports are found un-satisfactory, tests shall be carried out afresh by contractor without any additional cost implication to BHEL/ Powergrid.*
 - h. *Finishing colours shall be RAL 7035 for indoor panels/cubicles and RAL 7032 for outdoor panels/cubicles.*
 - i. *Bidder shall choose the makes from among the POWERGRID COMPENDIUM OF APPROVED VENDORS which are also available on POWERGRID website on the Internet. In case, no vendor is specified in the list against a particular item, only reputed makes available in the market shall be considered. All such makes shall be subjected to acceptance of POWERGRID. No additional price implication shall be made to BHEL on account of non-acceptance of proposed makes by POWERGRID.*

1.7.2 Scope of services

Erection, Testing & Commissioning (ETC) requirements

- a) The scope of ETC shall include receipt of material at site, safe storage of material, handling of equipment/material at site, erection of equipment /material at site including fabrication, equipment and system testing, commissioning of the entire system, conducting performance guarantee tests to the satisfaction of Owner/ Purchaser and handing over of the system to Owner/ Purchaser. All material, consumables plus tools & tackles required for completion of ETC work shall be arranged by the Bidder.
- b) Cable laying & termination between Fire Detection system panel to various Air Conditioning panels/controllers for effecting tripping of AC units in case of fire.
- c) Laying and termination of power and control cables for the equipment under the scope of this specification.
- d) Laying & fixing of cable trays on walls or elsewhere.
- e) All electrical components shall be properly earthed by the contractor to the nearest earthmat riser of the Owner / Purchaser.



- f) The contractor shall arrange all machinery -tools & tackles and consumables required for erection of the system.
- g) Contractor shall ensure that sufficient quantity of commissioning spares is made available for timely completion of commissioning of the system. The contractor shall furnish a list of commissioning spares that will be brought by him. The unused commissioning spares shall be returnable to the Contractor.
- h) Conducting Performance Guarantee tests to the satisfaction of Owner / Purchaser.
- i) After completion of erection and commissioning of the system, the contractor shall train site engineers of Purchaser/Owner so that they are fully conversant with both electrical and mechanical part of the package.
- j) *Submission of following documents for approval.***
 - i. Data sheet for 3TR Air conditioning units & Controller along with catalogue for the model being offered.
 - ii. Control philosophy of the working of AC units in conjunction with Controller as per our requirement given in this specification.
 - iii. Layout showing fixing arrangement of AC units and controller in the relay building and also wiring connections between two AC units, controllers and main power supply..
- k) The contractor shall furnish the operation and maintenance manual specifically compiled for each of the sub-stations. The draft O&M manual shall be submitted within 20 weeks after award of contract. The O&M manual shall contain the following information:
 - i) Description of the system and equipment with design particulars
 - ii) Instruction for erection.
 - iii) Instruction for operation, maintenance and repair.
 - iv) Recommended inspection practices and inspection schedule.
 - v) Ordering information for all replaceable parts.
 - vi) Recommendation for type of lubricants and frequency of lubrication.

1.8 CIVIL WORKS

Associated civil works such as grouting, filling up crevices/cut outs etc during installations of equipments shall also be in contractor's scope. Any other damage caused to civil works during ETC work of the equipment/system shall be made good to the original finish by the contractor at extra cost to the purchaser.

1.9 EXCLUSIONS (FREE ISSUE SUPPLY/ SERVICE TO CONTRACTOR BY BHEL)

- a) Supply of power & control cables for the system.
- b) Supply of necessary cable trays for laying power and control cables, wherever required.



-
- c) Supply of GI flat for earthing of equipments. GI wire, if required, shall be supplied by contractor.

1.10 INSPECTION & TESTING

Inspection shall be carried out by BHEL/Customer approved Quality Plan, data Sheet, Technical specifications and Drawings. All Equipments/BOIs to be sourced from approved sources.

1.11 UTILITIES AVAILABLE

Electricity shall be provided at one point and contractor shall make necessary provisions for distribution to its various points of usages.

1.12 HANDING & TAKING OVER

After successful commissioning, All the AC units will be put through a run test for a week as per the specification requirement. Any defect noted during this period shall be rectified by the contractor without any cost implication to BHEL/ Customer. After successful completion, they will be handed over to customer It is the responsibility of the Contractor to run and maintain the system till it is handed over to the owner. Contractor shall assist purchaser to hand over the plant to owner.



SECTION 2

Equipment Specification

2.1 GENERAL

- a) The design and construction of complete system shall comply with the latest applicable Indian/British/American Standards/Codes.
- b) All mechanical works shall satisfy the general technical requirements and shall be designed to operate in the ambient/system conditions specified in Section 3.
- c) The requirements mentioned under this clause are indicative and minimum for the system. Any other item/ service required to complete the work for safe and sound operation of system shall be provided and installed by the bidder at no extra cost to the purchaser. The bidder may bring out such requirement(s) suitably.

The following requirements shall be met by the equipment supplied by Contractor:

- i) The equipment shall be designed and constructed for safe, proper and continuous operation under all conditions described or implied in the Specification, without undue strain, vibration, corrosion or other operating difficulties.
- ii) Parts shall be designed and supported to permit free expansion and contraction without causing leakage, distortion or excessive strain on the equipment.
- iii) Parts subject to wear, corrosion or other deterioration or requiring adjustment, inspection or repair shall be readily accessible and capable of easy removal for repair or replacement.
- iv) All heavy components shall be provided with convenient means for slinging or handling during installation and maintenance.
- v) Duplicate and/or stand-by equipment shall automatically, based on a predetermined cycle, be brought on the system such as to allow an equal wear and tear.
- vi) Unless otherwise specified, all equipment serviced by a duplicate or stand-by shall, on detection of failure, get automatically isolated. The corresponding duplicate or stand-by equipment shall automatically take over the failed equipment.
- vii) Loss of any equipment or system shall automatically be alarmed at BUILDING MANAGEMENT SYSTEM.
- viii) The principles detailed above need not be applied to systems upon which the conversion equipment does not depend for operation.
- ix) No mechanical equipment shall be installed on the roof of the converter building, i.e. valve halls and service building.



2.2 AIR CONDITIONING UNIT DETAILS

The air conditioning unit shall be completely self- contained. All components of the unit shall be enclosed in a powder coated cabinet. The unit shall be assembled, wired, piped, charged with refrigerant and fully factory tested as a system to ensure trouble free installation & start up. Suitable Isolation or other bypassing arrangement shall be provided such that any unit/component could be maintained/ repaired without affecting the running stand by. The maintenance of the unit shall be possible from outside the panel room. The compressor shall be very reliable, trouble free and long life i.e. hermitically sealed scroll type of reputed make suitable for continuous operation. Compressor should be installed on vibration proof mounting or Manufacturer's recommended approved mounting. Valve shall be provided for charging/toping up of refrigerant. The Bidder shall furnish details of their compressor indicating the MTBF, life of compressor and continuous run time of the compressor without failure. The contractor shall also furnish details of all accessories i.e. refrigeration system, evaporator coil, condenser coil, evaporator blower filter; cabinet, indoor supply & return grill etc.



SECTION – 3

Project Details and General Technical Requirements

Please refer TB-343-316-000, Rev-01 "General Technical requirement –section-3"and relevant clauses of technical specification



±800KV, 6000MW, HVDC MULTI-TERMINAL NER/ER – NR/WR
INTERCONNECTOR-I PROJECT

General Technical Requirements- Section 3
Doc. No. : TB-343-316-000 Rev. 02

Index

3	General	3
3.1	Definitions	3
3.2	Instructions to suppliers	4
3.3	Standards	5
3.4	Site information	5
3.5	Site temperatures for design purposes	6
3.6	Documentation	6
3.7	Quality assurance requirements	10
3.8	Materials and workmanship	14
3.9	Colour schemes	15
3.10	Clamps & connectors	16
3.11	Name plates and markings	17
3.12	Provisions for exposure to hot and humid climate	19
3.12.1	Space heaters	19
3.12.2	Fungi static varnish	19
3.12.3	Ventilation opening	19
3.12.4	Tropicalisation	19
3.13	Painting and finishing of metal surfaces	19
3.14	Hot dip galvanising	20
3.15	Control cabinets, junction boxes, terminal boxes & marshalling boxes for equipment	21
3.16	Indoor control cubicles	24
3.16.1	Mounting	25
3.16.2	Earthing	25
3.16.3	Instruments, meters and recorders	26
3.16.4	Miscellaneous	26
3.16.5	Terminal blocks and wiring	27
3.17	Degree of protection	28
3.18	Welding and welders' qualifications	28
3.19	Motors	29
3.20	Conduits, pipes and accessories	29
3.21	Packaging & protection	30
3.22	Auxiliary supply	30
3.23	Lamps and sockets	30
3.24	Availability spares	31
3.25	Commissioning spares	31
3.26	Tools & tackles	31
3.27	Seismic force consideration	31
3.28	Safety requirements	32
	<i>Annexure-A</i> "Corona and radio interference voltage (RIV) test"	33



GENERAL TECHNICAL REQUIREMENTS-SECTION 3

3 General

The Works covered by the Specification shall be designed, manufactured, built, tested and commissioned in accordance with the Acts, Rules, Laws and Regulations of India. The Equipment(s) shall also conform to the general requirements detailed in the following standards, which shall form an integral part of the Specification, in addition to meeting the specific requirements called for elsewhere in the Specification.

The Supplier shall note that the standards mentioned herein are not mutually exclusive or complete in themselves, but are intended to complement each other, with minimum repetition, to define the requirements of the Specification. In the event of a conflict between requirements of any two clauses of the Specification/ documents or requirements of different codes/ standards specified, the more stringent requirement as per the interpretation of the owner shall apply, unless confirmed otherwise by the owner in writing based on a written request from the Supplier.

In case of conflicting requirements between this document (General Technical Requirements - Section 3) and equipment specification (Section 1 & Section 2), equipment specification shall prevail.

When specific requirements stipulated in the Specification exceed or change those required by the applicable standards, the stipulations of the Specification shall take precedence.

Unless specifically agreed to by the Purchaser prior to Award of Contract, the Work shall be in accordance with the standards indicated and the requirements of the Specification. The Supplier shall be held responsible for any deviation.

In case of conflict between the various standards, the decision of owner shall be binding & final.

3.1 Definitions

The following words and expressions shall have the meanings hereby assigned to them throughout this document

"Biswanath Chariali " means Biswanath Chariali Converter Station

"Alipurduar " means Alipurduar Converter Station

"Agra" means Agra Converter Station

"Employer/Owner" means Power Grid Corporation of India Ltd.

"Purchaser" means Bharat Heavy Electricals Limited

"Supplier/Manufacturer" means the person or persons, firm or company assigned to execute the works as defined by the scope of supply, described here.



**±800KV, 6000MW, HVDC MULTI-TERMINAL NER/ER – NR/WR
INTERCONNECTOR-I PROJECT**

**General Technical Requirements- Section 3
Doc. No. : TB-343-316-000 Rev. 02**

"Specification" refers to this document.

3.2 Instructions to Suppliers

The supplier should be approved by Power Grid. If not, it is the responsibility of the vendor to be assessed and approved by Power Grid, before placement of order by BHEL. Any cost involved in vendor assessment/approval must be borne by the vendor himself.

The supplier shall submit the technical requirements, data and information as per the technical data sheets provided in the appropriate clause of bid document.

Equipment furnished shall be complete in every respect with all mountings, fittings, fixtures and standard accessories normally provided with such equipment and/or needed for erection, completion and safe operation of the equipment as required by applicable codes though they may not have been specifically detailed in the Specifications unless included in the list of exclusions. Materials and components not specifically stated in the specification but which are necessary for commissioning and satisfactory operation of the switchyard/substation unless specifically excluded shall be deemed to be included in the scope of the specification and shall be supplied without any extra cost. All similar standard components/parts of similar standard equipment provided, shall be inter-changeable with one another.

The Supplier shall offer equipment whose similar equipment for similar applications have been in service for at least two years from the date of first stage bid opening (30-06-2009) and should have been type tested as per relevant standards.

The suppliers who have supplied 400 kV equipment rated for 40 kA earlier to POWERGRID, may supply 50 kA rated equipment subject to fulfilling specified requirements:

The supplier shall supply type tested (including special tests as per tech. specification) equipment and materials. The Employer shall accept the equipment type test reports under the following conditions:

(i) Type test in accordance with the relevant specified standards

(ii) Type tests performed within five (5) years from the date of first stage bid opening (30-06-2009)

(iii) The type tested equipment shall be of the same design, insulation class and rating as per the equipment offered under this contract

In the event that equipment furnished includes important modifications of, or significant departure from, the designs of equipment on which type test report has been furnished or if there is evidence that the equipment does not comply with the requirements of the Specifications, the Supplier shall conduct the type test without any cost implication to the Purchaser. In the price bid, the type test charges shall be included and no separate type test charges shall be indicated by the supplier.

Acceptance of the type test reports shall be at the discretion of the Employer. All type tests



**±800KV, 6000MW, HVDC MULTI-TERMINAL NER/ER – NR/WR
INTERCONNECTOR-I PROJECT**

**General Technical Requirements- Section 3
Doc. No. : TB-343-316-000 Rev. 02**

performed after the date of award of the Contract shall be witnessed by the Employer unless authority to proceed with the tests in his absence is received from the Employer in writing.

3.3 Standards

All equipment and materials, unless otherwise specifically required in the Specification, shall conform to latest revisions of the standards listed in the Specification, in force at the time of signing of the contract for this project.

Generally the standards listed in the specification are applicable in accordance with the specific requirements of the technical section covering particular alternating current equipment or materials.

3.4 Site information

Table 3.4 - 1 Table for site information

<i>Particular</i>	<i>Biswanath Chariali</i>	<i>Alipurduar</i>	<i>Agra</i>
a) Employer/Owner	<i>Power Grid Corporation of India Ltd (POWERGRID)</i>		
b) Project Title	<i>±800 kV, 6000 MW HVDC Multi terminal System Package</i>		
c) Location	<i>70 km from Tezpur in Sonitpur district of Assam, Kolkatta port is the nearest port to the site</i>	<i>175 Kms. from Siliguri city in the state of West Bengal. Kolkatta port is the nearest port to the site</i>	<i>12.6 Km Agra-Shamsabad road PO – Shyamo, Agra</i>
d) Nearest Rail Head	<i>Guwahati</i>	<i>Alipurduar junction</i>	<i>Agra</i>
e) Postal Address	<i>To follow</i>	<i>To follow</i>	<i>To follow</i>
f) Design ambient temp.	<i>40°C</i>	<i>40°C</i>	<i>50°C</i>
g) SEISMIC COEFFICIENT	<i>Zone V Importance factor for the stations is 1.5 as per table no. 6 of IS-1893.</i>	<i>Zone IV Importance factor for the stations is 1.5 as per table no. 6 of IS-1893.</i>	<i>Zone III Importance factor for the stations is 1.5 as per table no. 6 of IS-1893.</i>
h) Site Wind Pressure	<i>Zone V with basic wind speed of 50 m/s at 10 m height above mean ground level. The risk level coefficient/factor shall be taken as 1.07.</i>	<i>Zone IV with basic wind speed of 47 m/s at 10 m height above mean ground level. The risk level coefficient/factor shall be taken as 1.07.</i>	<i>Zone III with basic wind speed of 44 m/s at 10 m height above mean ground level. The risk level coefficient/factor shall be taken as 1.07.</i>
i) Isokeraunic Level	<i>150 days per year</i>	<i>150 days per year</i>	<i>50 days per year</i>
j) Relative Humidity	<i>Max. 100%</i>		
k) Rain fall Intensity	<i>In 24 hours: 250mm 80mm/hr (for drainage system Design)</i>	<i>In 24 hours: 250mm 80mm/hr (for drainage system Design)</i>	<i>In 24 hours: 200mm, 30mm/hr (for drainage system Design)</i>



**±800KV, 6000MW, HVDC MULTI-TERMINAL NER/ER – NR/WR
INTERCONNECTOR-I PROJECT**

**General Technical Requirements- Section 3
Doc. No. : TB-343-316-000 Rev. 02**

3.5 Site temperatures for design purposes

The Supplier shall assume the temperatures given below for the design of the works at the converter stations.

Table 3.5 - 2 Table for Site temperatures

<i>Description Site</i>	<i>Temperature in deg C</i>		
	<i>Biswanath Chariali</i>	<i>Alipurduar</i>	<i>Agra</i>
<i>Maximum dry bulb one hour average</i>	40	40	50
<i>Maximum dry bulb 24 hour average</i>	40	40	40
<i>Annual mean dry bulb temperature</i>	30	30	30
<i>Minimum dry bulb one hour average</i>	0	0	0
<i>Maximum wet bulb one hour average</i>	33	33	33
<i>Dry bulb temperature for low ambient condition</i>	33	33	33
<i>Wet bulb temperature for low ambient condition</i>	23	23	23

3.6 Documentation

All technical description, specifications, literature, correspondence, prints, drawings, instruction manuals, test reports(both factory and site), progress photographs, booklets, schedules and all supplementary data or documents furnished in compliance with the requirements of the Contract, shall become the property of the Purchaser/owner and the costs shall be considered as included in the Contract price.

The Supplier shall be responsible for any time delay, misinterpretation, error and conflict during design, manufacturing, testing and erection of the Works resulting from non-compliance with the requirements of this Specification.

The Purchaser/owner shall have the right to make copies of any documents, data, reports, information etc. supplied by the Supplier in connection with the Works. The Purchaser/ owner shall not impart the information of these documents to any other manufacturer or competitor but he shall be free to use these for preparation of technical papers, reports etc.

The Supplier shall submit consolidated list of all symbols used in any drawing, data and information under three separate headings namely Civil, Mechanical & Electrical. If symbols other than IS or IEC are used, the Supplier shall submit consolidated list of these symbols and their significance under a separate section.

The Supplier is not required to supply detailed drawings whose purpose is manufacture only but in case such information is specifically asked for by the Purchaser/owner during evaluation of Bid, finalization of Contract, design review by Purchaser/owner his appointed Consultant or during execution of the Contract, the Supplier shall comply with the same.

All drawings, documents manual etc. as specified in this section shall have to be provided separately for each station.

All documentation shall be in English language.

Requirements for submission of documents, information and data by the supplier



**±800KV, 6000MW, HVDC MULTI-TERMINAL NER/ER – NR/WR
INTERCONNECTOR-I PROJECT**

**General Technical Requirements- Section 3
Doc. No. : TB-343-316-000 Rev. 02**

General

The Supplier shall submit to the Owner/Purchaser all documents in accordance with an approved schedule of submissions and shall submit any further information (in the form of drawings, documents, manuals, literature, reports etc.) when asked by the Owner/Purchaser while commenting/approving any drawings/documents etc. All applicable documents shall be provided for each converter/repeater station separately.

The documents which are subject to the approval of the Owner/Purchaser shall be identified by the Supplier with the stamp "FOR APPROVAL". All other documents shall be submitted to the Owner/Purchaser for information and shall be identified by the Supplier with the stamp "FOR INFORMATION".

The sequence of submission of the documents shall be subject to the approval of the Employer. The sequence of submissions of all documents shall be such that the necessary information is available to enable the Employer to approve or comment the document.

The Supplier shall supply 5 hard copies of all drawings and documents. The final documentation for the project shall be supplied in nine sets of hard copies (three to each site) and nine sets of CDs to the Purchaser.

The entire plant documentation shall include all construction drawings, equipment specifications, design/study reports, O&M documents, factory test reports, etc. All the final/as built drawings shall be submitted in CAD format along with the complete final documentation.

In case a "SUBSEQUENT" revision of any document is made due to any reason whatsoever, a revision of the same, highlighting the changes shall be resubmitted for the Employer's specific approval/information.

Documents for approval

Approved documents shall be considered as the working documents. However the Specification and connected documents shall prevail over these documents in case a decision is required on interpretation.

Documents for information

The Supplier shall not delay the Works pending the receipt by the supplier of the comments on documents submitted to the Owner/Purchaser for information. However, the Owner/Purchaser shall have the right to comment on all the documents submitted by the Supplier, when, in the opinion of the Owner/Purchaser the document does not comply with the Contract or otherwise. The Supplier shall satisfactorily demonstrate that the information contained in the aforesaid document does meet the requirements of the Contract or revise the document in order that the information shall comply with the requirements of the Contract.

Drawings and data

General

The Supplier shall submit to the Owner/Purchaser all assembly and detail drawings of equipment,



**±800KV, 6000MW, HVDC MULTI-TERMINAL NER/ER – NR/WR
INTERCONNECTOR-I PROJECT**

**General Technical Requirements- Section 3
Doc. No. : TB-343-316-000 Rev. 02**

station design, civil work, building, controls, protection, etc., as well as the corresponding computation where necessary in order to establish to the satisfaction of the Owner/Purchaser the Supplier's compliance with the requirements of the Contract.

Drawings, as set forth below shall be submitted to the Owner/Purchaser and shall be complete with all information necessary for complete interpretation of the drawings by the Owner/ Purchaser. All drawings shall show the materials, dimensions, finish, fits, clearances, tolerances, bolting and such other information as is necessary to demonstrate to the Owner/ Purchaser that all items covered by the drawings are in compliance with the requirements of the Contract.

Drawings may consist of several sheets as required in order to provide for the degree of detail required by the Employer, so that he may clearly understand such drawings.

Not later than 90 (ninety) days after completion of successful trial operation of the HVDC station, the Supplier shall supply copies of the last revision of all drawings produced for this project, stamped as "AS BUILT".

The Supplier shall provide separate sets of drawings for each control cubicle. Typical drawings for similar cubicles shall not be accepted. If there are several cubicles per system, then one common bill of material and one system schematic diagram may be provided. Such system schematic diagram shall show the control scheme for the particular system in its entirety and shall be laid out on the minimum number of drawings sheets consistent with clarity and legibility.

The Owner/Purchaser shall not accept typical drawings for control, protection and three-phase schematics, power circuits and single line diagrams. The Supplier shall supply complete set of such drawings for each system, even when drawings are duplicates.

Inspections plans and documentation

The Supplier shall submit in required number copies for the Owner's/Purchaser's approval an inspection plan (quality plan) describing the inspection system indicating the inspections to be carried out and their sequence in the manufacturing stages.

The inspection plan shall be such that it can be related to the manufacturing program. The plan shall also include a description of the inspection methods employed with reference to the Supplier's written inspection procedures.

Separate inspection plans describing the inspection systems for equipment supplied by each sub-Supplier, in the same form as that of the Supplier, shall be submitted for the approval of the Owner/Purchaser.

In addition to the inspection plans referred to above, the Supplier shall submit complete and satisfactory evidence of possessing a working scheme assuring the control of all critical activities pertinent to the assurance of quality, and objective evidence (by means of quality manuals and appropriate forms, etc.) of this capability to employ and maintain quality control to meet the required quality level of the manufacture and construction of the Works.

Supplier's Quality Control Program in the context of this Clause means the implementation of a quality assurance program by means of which full conformance of material and workmanship to best



**±800KV, 6000MW, HVDC MULTI-TERMINAL NER/ER – NR/WR
INTERCONNECTOR-I PROJECT**

**General Technical Requirements- Section 3
Doc. No. : TB-343-316-000 Rev. 02**

quality standards can be achieved effectively and economically by the Supplier's control and surveillance of all essential inspection operations, and periodic verification of the results of the manufacture of equipment and the assembly, erection and installation of equipment at the sites.

Required number of copies of all test reports, including those supplied by Sub-Suppliers, and shall be submitted to the Owner/Purchaser for approval. The Supplier shall include in the report all additional data required by the Owner/Purchaser to permit a clear understanding of the reports.

All test reports shall be certified and shall contain the signature of the Inspector as having witnessed the test, unless such witnessing has been specifically waived by the Owner/ Purchaser. A certified test report shall be issued for each test.

Instruction manuals and operating manuals

The Supplier shall provide Instruction & Maintenance Manuals for each part of the Plant and Equipment included in the Works and Operating Manuals for each Station.

The Instruction Manuals and Operating Manuals shall be arranged in an organized library adequately cross referenced to facilitate issuing clauses of the manuals as required by the work i.e. erection instructions shall be required before operating & maintenance instructions.

All Manuals provided by the Supplier shall be fully detailed and specifically prepared for the Works and equipment provided. General manuals not specifically required for the work shall not be acceptable.

The instruction manuals shall at least contain:

- a) A general description of all components
- b) Storage instructions
- c) Erection instructions
- d) Pre-commissioning Instruction :
- e) Material and part list.
- f) Design clearances and settings
- g) Complete sets of drawings as finally issued
- h) Operating Instructions:
- i) Routine and Preventive Maintenance instructions with material requirement for each site
- j) Preventive Maintenance Schedule.
- k) Replacement instruction for all equipment

The operation manuals shall at least contain:

- a) Operator oriented functional descriptions of the equipment.
- b) Operator oriented description of the protection and control systems
- c) Description of the equipment auxiliary systems
- d) Fault finding and diagnostic tools
- e) User software interface tools for modification/augmentation etc.

Notes:

The supplier may please note that all resubmissions must incorporate all comments given in the ear-



**±800KV, 6000MW, HVDC MULTI-TERMINAL NER/ER – NR/WR
INTERCONNECTOR-I PROJECT**

**General Technical Requirements- Section 3
Doc. No. : TB-343-316-000 Rev. 02**

lier submission by the Owner/Purchaser or adequate justification for not incorporating the same must be submitted failing which the submission of documents is likely to be returned.

If after the commissioning and initial operation of the substation, the instruction manuals require any modifications/ additions/changes, the same shall be incorporated and the updated final instruction manuals shall be submitted by the Supplier to the Owner/Purchaser.

The Supplier shall furnish to the Owner/Purchaser, catalogues of spare parts also.

3.7 Quality assurance requirements

Quality assurance programme

To ensure that the equipment and services under the scope of Contract, whether manufactured or performed at the Supplier's Works or at his Sub-supplier's premises or at the Purchaser's site or at any other place of Work, are in accordance with the specifications, the Supplier shall adopt a suitable quality assurance programme to control such activities at all points, as necessary. Such programme shall be outlined by the Supplier and shall be submitted by the supplier after the award of contract and finally accepted by the owner after discussions prior to commencement of manufacturing.

A quality assurance programme of the supplier shall generally cover the following:

- (a) Supplier's organisation structure for the management and implementation of the proposed quality assurance programme;
- (b) Design and Documentation control system;
- (c) Qualification data of Supplier's key personnel;
- (d) The procedure for purchases of materials, parts components and selection of sub-Supplier's services including vendor analysis, source inspection, incoming raw material inspection, verification of material purchased etc.
- (e) System for shop manufacturing and site erection controls including process controls and fabrication and assembly control;
- (f) Control of non-conforming items and system for corrective actions;
- (g) Inspection and test procedure both for manufacture and field activities;
- (h) Control of calibration and testing of measuring and testing equipment.
- (i) System for quality audits;
- (j) System for indication and appraisal of inspection status
- (k) System for authorising release of manufactured product to the Purchaser
- (l) System for maintenance of records;
- (m) Furnishing of quality plans (QP)/inspection and test plan (ITP) for manufacturing and field activities detailing out the specific quality control procedure adopted for controlling the quality characteristics relevant to each item of equipment/component.

General requirements - Quality assurance

1. All services, materials, components and equipment covered under this specification shall be engineered, designed, procured, manufactured, erected, commissioned and tested at all the stages, as per a comprehensive Quality Assurance Programme. It is the Supplier's responsibility to draw up and implement agreed programme for system as a whole as well as for individual equipment.



**±800KV, 6000MW, HVDC MULTI-TERMINAL NER/ER – NR/WR
INTERCONNECTOR-I PROJECT**

**General Technical Requirements- Section 3
Doc. No. : TB-343-316-000 Rev. 02**

The detailed Quality Plans for manufacturing and field activities shall be drawn up by the Supplier and shall be submitted to the Employer for approval.

The Supplier shall furnish with his bid a list of approved suppliers for the information of the Employer.

2. Engineering and design quality Plan shall detail out the studies, overall detail design documentation and communicating, defining interfaces and controlling changes. To achieve quality, reliability and schedule objectives that project shall be designed so that it meets performance requirements. Manufacturing Quality Plan shall detail out for all the components and equipment, various tests/inspection, to be carried out as per the requirements of this Specification and standards mentioned therein and quality practices and procedures followed by Supplier's Quality Control Organisation, the relevant reference documents and standards, acceptance norms, inspection documents etc., during all stages of materials procurement, manufacture, assembly, and final testing/performance testing.
3. Field Quality Plan shall detail out for all the equipment, the quality practices and procedures etc. to be followed by the Supplier's site Quality Control Organisation, during various stages of site activities from receipt of materials/equipment at site onwards.
4. The Supplier shall also furnish copies of the reference documents/plant standards/ acceptance norms/tests and inspection procedure etc., as referred in Quality Plans along with respective Quality Plan. These Quality Plans and reference documents/standards etc. shall be subject to Employer's approval without which manufacture shall not proceed. In these approved QPs, the Employer shall identify customer inspection points (CIP), test/checks which shall be carried out in presence of the Employer's Engineer or his authorised representative and beyond which the work shall not proceed without consent of Employer or his authorised representative in writing. All deviations to specification, approved quality plans and applicable standards must be documented and referred to the Employer for approval and disposition.
5. No material shall be dispatched from the manufacturer's works before the same is accepted subsequent to pre-dispatch final inspection including verification of records of all previous tests/inspections by Employer's Engineer and / or his authorised representative, and duly authorised for dispatch issuance of Material Inspection Clearance Certificate (MICC). Before making request for issuance of MICC, the Supplier shall ensure that approval of type tests, data sheets, drawing etc. had already been obtained from Employer. All materials used or supplied shall be accompanied by valid materials certificates and tests and inspection reports. These certificates and reports shall indicate the sheet numbers or other such acceptable identification numbers of the material. The material certified shall also have the identification details stamped on it.
6. All welding and brazing shall be carried out as per procedure drawn and qualified in accordance with requirements of ASME section - IX/BS-4870 or other International equivalent standard acceptable to the Employer.
7. All the (sub)-Vendors proposed by the Supplier for procurement of bought out item list of which shall be drawn up by the Supplier and finalised with the Employer shall be subject to the Employer's approval. Quality Plans of the successful vendors shall be discussed, finalised and approved by the Employer and shall form part of the purchase order between the Supplier and the Vendor.



**±800KV, 6000MW, HVDC MULTI-TERMINAL NER/ER – NR/WR
INTERCONNECTOR-I PROJECT**

**General Technical Requirements- Section 3
Doc. No. : TB-343-316-000 Rev. 02**

8. The Employer reserves the right to carry out quality audit and quality surveillance of the systems and procedures of the Supplier's of their sub-Supplier's (sub-vendor's) quality management and control activities. The Supplier shall provide all necessary assistance to enable the Employer carry out such audit and surveillance.
9. As a part of quality assurance of engineering and design, the technical review meetings (TRMs) shall be conducted between the Employer and/or his consultants/representative and the Supplier and/or his subSupplier(s). The duration and cycle of such TRMs shall be as frequent and regular as required to meet the time schedules. The meetings shall be held at either at the Employer's office and/or at the office/manufacturing place of the Supplier/sub-Supplier or at any other place as agreed mutually.
10. The Supplier shall agree upon a schedule of submissions of documents concerning the Quality Assurance Program within two months of the effective date of the Contract. This schedule shall indicate the list of mutually agreed items/equipment for which quality Plans shall be submitted by the Supplier and the last dates for the submissions. It shall be ensured by the Supplier that the submissions are so programmed that all relevant approvals are obtained from the Employer for these documents in a timely manner before the material induction and commencement of the manufacture for any equipment.
11. The documents that shall be submitted by the Supplier to the Employer for review and approval as per the agreed schedule include:
 - a) QA Manuals
 - b) Quality Plans (Inspection & Test Plans) for all equipment/materials manufactured in the Supplier's works and/or in the sub-Supplier's works
 - c) Purchase Specifications for equipment procured from sub- Suppliers.
 - d) Supplier's assessment reports of his sub-Suppliers
 - e) Field Quality Plans for all activities at site
 - f) Reference documents referred to in Quality Plan.
 - g) Erection, commissioning, operation and maintenance manuals

12. QA Document Package

The Supplier shall submit the following Quality Assurance Documents to the Employer. These documents shall be as per the approved Quality Plans for the concerned equipment. The documents shall include, but not limited to, the following:

- a) Routine test reports & Acceptance test reports
- b) Type test reports
- c) Quality records etc. corresponding to items identified Quality Plan
- d) Inspection reports for Customer inspection points
- e) Reports on repair/modification carried out to make the item/equipment acceptable.
- f) Non-destructive examination result reports including radiography interpretation reports, wherever applicable.

The above documents are required to be submitted in required number of copies within three weeks after dispatch of equipment.



Inspection and testing

1. In order to verify that all the manufacturing of equipment by the Supplier as well as materials & equipment being procured and provided by the Supplier are in complete conformance with the requirement of the Contract, the Employer and/or his duly authorized representative shall have access to the Supplier's premises or works at all reasonable times to inspect and examine the material, equipment and workmanship during its manufacture or installation. In addition to carrying out inspection the Employer and/or his authorized representative/Consultant all carry out quality audit on the Supplier's Quality Assurance System and conduct quality surveillance to check conformance to quality procedure/practice in general. The Supplier shall provide necessary facilities to carry out all the above activities at their works and the works of the sub-Suppliers.
2. The Supplier shall provide a detailed inspection schedule for those inspection stages identified as CIP and shall furnish updated schedules once every two months.
3. The Supplier shall give the Employer/Inspector six(6) weeks written notice, by telex or by letter, of the tentative date any material/equipment shall be ready for witness points, corresponding to Customer inspection points (CIP), when the Employer/Inspector is based in India. Final confirmation shall be given at least 15 days in advance. The Employer/Inspector, unless witnessing of the tests is waived, shall attend such tests, failing which the Supplier may proceed with the test which shall be deemed to have been made in the Inspector's presence. The Supplier shall forthwith forward to the Employer copies of duly certified test reports. Test reports of all tests corresponding to CIP performed in the supply shall be reviewed and approved, subject to satisfactory conduction and successful passing of the test, by the Employer or his authorized representative (even if the witnessing of the test was waived).
4. The Employer or his authorized representative shall, within fifteen (15) days from receipt of such reports, give notice in writing to the Supplier of any objection to any aspect of the test reports or any or all equipment and workmanship which in his opinion is not in conformance with the Contract. The Employer or his authorized representative shall advise his reasons for objections on completion and review of the activity. The Supplier shall give due consideration to such objection(s) and shall either make the modifications that may be necessary to overcome the said objection(s) or shall confirm in writing giving reasons therein that no modifications are necessary to comply with the Contract. However, the Supplier may proceed with the works/dispatch even before the receipt of written objection(s), if any, at his own cost & risk.
5. Whenever the Employer's inspection engineer undertakes the inspection, at a particular stage identified as Customer inspection point (CIP) in the Quality Plan, the acceptance of test reports/test results and the MICC where applicable shall be given immediately after the test if the results, including those for previous points identified as per clause 9.6 are found to be in conformity with the Contract. In case of any deviations, the Employer/Inspector at his discretion may refer the matter to the Employer's main office, together with the manufacturer's comments, who in turn shall communicate his final decision regarding the acceptance or otherwise to the Supplier within fifteen (15) days of the receipt of such test reports/results. In case the presence of the Employer/Inspector is waived, the acceptance of test results and issuance by the Employer of Material Inspection Clearance certificate wherever applicable, shall be given within fifteen (15) days after receipt of test reports/results for the CIP as well as for previous CIP's identified in the approved Quality Plan, provided such test reports/test results are found to be in order. The Em-



**±800KV, 6000MW, HVDC MULTI-TERMINAL NER/ER – NR/WR
INTERCONNECTOR-I PROJECT**

**General Technical Requirements- Section 3
Doc. No. : TB-343-316-000 Rev. 02**

ployer/Inspector shall at his discretion and based on the outcome of any inspection and the requirements of the contract, have the right to 'accept', 'accept as noted' or 'reject' any equipment/material. The reasons/comments in case of each ruling shall be communicated to the Supplier in writing.

6. In all cases where the contract provides for tests, whether at the premises of works of the Supplier or of any sub-Supplier, the Supplier, except where otherwise specified, shall provide free of charge such items as labour, materials, electricity, fuel, water, apparatus and instruments as required to fulfil the requirements of the approved Quality Plan.
7. The inspection by Employer/Inspector or waiver of the presence of the Employer/Inspector, issue of CIP clearance certificate and issue of Material Inspection clearance certificate (MICC) thereon shall in no way limit the liabilities and responsibilities of the Supplier in respect of the agreed quality plans forming part of the contract. The Employer shall not be found to accept the material/equipment if on further testing it is found to be not in compliance with the requirements of the contract. The Supplier shall include in all orders to his sub-Suppliers, the requirements for any equipment, being supplied by the sub-Supplier for incorporation in his equipment to be subjected to inspection and testing by the Employer or is authorised representative. Copies of such orders or purchase specifications, blanked for prices, shall be forwarded to the Employer.
8. The costs of all tests specified in the Contract together with the same for all tests facilities, test samples and such like shall be to the Supplier's account.
9. The Employer/Inspector shall have complete authority to reject, on behalf of the Employer, any material, equipment or parts thereof considered unsatisfactory and not in accordance with the Contract. Accept, accept as noted or reject materials, equipment or any components thereof shall not relieve the Supplier of any of his obligations under the Supplier, nor impose any liability whatsoever on the Employer.
10. The Employer shall have the right to have Inspectors on the Sites, on a regular basis or from time to time as required at his sole discretion to monitor the quality and the progress of the work. Generally the site inspection shall be as per the approved Field Quality Plans (FQPs) and the Installation & Operation Manual(s). All quality related documents and test results shall be a part of plant documentation.

3.8 Materials and workmanship

Where the specification does not contain references to workmanship, it is understood that the equipment shall be new, of the best quality and in accordance with the purpose for which they are intended.

In case where the equipment, materials or components are indicated in the specification as "similar" to any special standard, the owner shall decide upon the question of similarity. When required by the specification or when required by the Purchaser & owner the Supplier shall submit for approval, all the information concerning the materials or components to be used in manufacture. Machinery, equipment, materials and components supplied, installed or used without such approval shall run the risk of subsequent rejection, it being understood that the cost as well as the time delay associated with the rejection shall be borne by the Supplier.



**±800KV, 6000MW, HVDC MULTI-TERMINAL NER/ER – NR/WR
INTERCONNECTOR-I PROJECT**

**General Technical Requirements- Section 3
Doc. No. : TB-343-316-000 Rev. 02**

The design of the Works shall be such that installation, future expansions, replacements and general maintenance may be undertaken with a minimum of time and expenses. Each component shall be designed to be consistent with its duty and suitable factors of safety shall be used throughout the design.

All joints and fastenings shall be devised, constructed and documented so that the component parts shall be accurately positioned to fulfil their required function. In general, screw threads shall be standard metric threads. The use of other thread forms will only be permitted when prior approval has been obtained from the owner.

Whenever possible, all similar parts of the works shall be made to gauge and shall also be made interchangeable with similar parts. All spare parts shall also be made interchangeable and shall be made of the same materials and workmanship as the corresponding parts of the equipment supplied under the specification. All the equipment of the same type and rating shall be physically and electrically interchangeable.

All materials and equipment shall be installed in strict accordance with the manufacturer's recommendation(s). All factory assembled rotating machinery shall be checked for alignment and adjustments made as necessary. The spare equipment(s) shall be installed at designated locations and tested for healthiness.

The Supplier shall apply oil and grease of the proper specification as is necessary for the installation of the equipment. Lubricants used for installation purposes shall be drained out and the system flushed through where necessary in readiness for applying the lubricant required for operation. The Supplier shall apply all operational lubricants to the equipment installed by him. All insulating oil, lubricating material, grease and other consumables used in the Works/ Equipment shall be purchased in India unless the Supplier has any special requirement for the specific application for a type of oil or grease not available in India. If such is the case he shall declare in the proposal where such oil or grease or other consumables is available. In any case he shall identify equivalent Indian makes and inform the Purchaser & owner of the name of at least two Indian suppliers before handing over of the Works to the Purchaser. All consumables required upto operational acceptance shall be the part of supply scope of the Supplier.

The supplier shall perform all tests and inspection necessary to ensure that the material and workmanship conform to the approved design drawings and that such tests are adequate to demonstrate that the equipment shall comply with the requirements of the Specification & relevant standards. The supplier shall test the component parts at his plant or his Sub-supplier's plant, prior to packaging and shipping, to determine that the performance requirements have been met. All testing shall be in accordance with the Standards related to the piece of work.

3.9 Colour schemes

The Supplier shall propose a colour scheme for the equipment for the approval of the Employer. The decision of the Employer shall be final. However, the finishing colour shall be RAL 7035 for indoor panels and RAL 7032 for outdoor panels. The scheme shall include:

- Finishing colour of Indoor equipment
- Finishing colour of Outdoor equipment
- Finishing colour of various auxiliary system equipment including piping
- Finishing colour of various building items.



±800KV, 6000MW, HVDC MULTI-TERMINAL NER/ER – NR/WR
INTERCONNECTOR-I PROJECT

General Technical Requirements- Section 3
Doc. No. : TB-343-316-000 Rev. 02

- Finishing colour of all cubicles.

All steel structures, plates etc shall be painted with non-corrosive paint on a suitable primer. The galvanised structures in the switchyard shall not be painted. However galvanised structures in other areas may require painting for aesthetic reasons.

3.10 Clamps & connectors

- i) All power clamps and connectors shall conform to IS: 5561, and/or IEC standard and shall be made of materials listed below:

a)	For connecting ACSR conductors	Aluminium alloy casting, conforming to designation A6 of IS: 617 and shall be tested for all tests as per IS:617
b)	For connecting equipment terminals made of copper with ACSR conductors	Bimetallic connectors made from aluminium alloy casting, conforming to designation A6 of IS 617 with 2 mm thick Bimetallic liner and shall be tested as per IS: 617.
c)	For connecting G.I. Shield wire	Galvanised mild steel
d).1	Bolts, nuts & Plain washers.	Electro galvanised for sizes below M12, for others hot dip galvanised
d).2	Spring washers for items 'a' to 'c'	Electro-galvanised mild steel suitable for at least service condition-3 as per IS: 1573

- ii) Equipment shall be supplied with the necessary terminals and connectors, as required by the ultimate design for the particular installation. The conductor terminations of equipment shall be either expansion, sliding or rigid type. The requirements regarding external corona and RIV as specified for any equipment shall include its terminal fittings and the equipment shall be factory tested with the connectors in position. In case the connector is not available then equivalent connector may be used. If corona rings are required to meet these requirements they shall be considered as part of that equipment and included in the scope of Work.
- iii) Where copper to aluminium connections are required, bi-metallic clamps shall be used, which have been properly designed to ensure that any deterioration of the connection is kept to a minimum and restricted to parts which are not current t shall be furnished to the Employer.
- iv) Low voltage connectors, grounding connectors and accessories for grounding all equipment as specified are also included in the scope of Work.
- v) No current carrying part of any clamp shall be less than 10 mm thick. All ferrous parts shall be hot dip galvanised. Copper alloy liner of minimum 2mm thickness shall be cast integral with aluminium body for Bi-metallic clamps. When copper alloy is not cast integral with aluminium body, a bimetallic washer or strip shall be used to meet the functional requirement.
- vi) All casting shall be free from blow holes, surface blisters, cracks and cavities. All sharp edges and corners shall be blurred and rounded off.



**±800KV, 6000MW, HVDC MULTI-TERMINAL NER/ER – NR/WR
INTERCONNECTOR-I PROJECT**

**General Technical Requirements- Section 3
Doc. No. : TB-343-316-000 Rev. 02**

- vii) Flexible connectors, braids or laminated straps made for the terminal clamps for bus posts shall be suitable for both expansion or through (fixed/sliding) type connection of IPS Aluminium tube as required. In both the cases the clamp height (top of the mounting pad to centre line of the tube) should be same.
- viii) Clamp shall be designed to carry the same current as the conductor and the temperature rise shall be equal or less than that of the conductor at the specified ambient temperature. The rated current for which the clamp/connector is designed with respect to the specified reference ambient temperature, shall also be indelibly marked on each component of the clamp/connector, except on the hardware.
- ix) All current carrying parts shall be designed and manufactured to have minimum contact resistance.
- x) TESTS

The following is the list of type tests.

- a) Temperature rise test (maximum temperature rise allowed is 35deg C over 50 deg C ambient)
- b) Short time current test
- c) Dry corona and RIV test as per annexure-A
- d) Resistance test and tensile test

3.11 Name Plates and Markings

All equipment mounted on front and rear side as well as equipment mounted inside the panels shall be provided with individual nameplates with equipment designation engraved. Also on the top of each panel on front as well as rear side, large and bold nameplates shall be provided for circuit/feeder designation.

All front mounted equipment shall also be provided at the rear with individual name plates engraved with tag numbers corresponding to the one shown in the panel internal wiring to facilitate easy tracing of the wiring.

All relays and other devices shall be clearly marked with manufacturer's name, manufacturer's type, serial number and electrical rating data.

Name Plates shall be made of non-rusting metal or 3-ply lamicaid. Name plates shall be black with white engraving lettering.

All the panels shall be provided with nameplate mounted inside the panel. Stainless steel nameplates shall be installed on all apparatus and on all major equipment components. For indoor cubicles, nameplates made of aluminium shall also be acceptable. Name plates shall be white with black engraved lettering and shall carry all the applicable information specified in the applicable items of the Standards, together with any other relevant information which may be required. For groups of smaller items for which this is not possible e.g. switch bays etc. a common nameplate with the title and special instructions on it shall be provided. No scratching, corrections or changes shall be allowed on nameplates. Main equipments like converter transformer, CBs, Reac-



**±800KV, 6000MW, HVDC MULTI-TERMINAL NER/ER – NR/WR
INTERCONNECTOR-I PROJECT**

**General Technical Requirements- Section 3
Doc. No. : TB-343-316-000 Rev. 02**

tor, Filter gates etc shall have nameplates in Hindi also.

All equipment mounted on front and rear sides as well as equipment mounted inside the panels shall be provided with individual name plates with equipment designation engraved. Also on the top of each panel on front as well as rear sides large name plates with bold size lettering shall be provided for circuit / feeder / cubicle / box designation.

All front mounted equipment shall also be provided at the rear with individual name plates engraved with tag numbers corresponding to the one shown in the panel internal wiring to facilitate tracing of the wiring. The nameplates shall be mounted directly by the side of the respective equipment and shall not be hidden by the equipment wiring.

The nameplate inscription and size of nameplates and letters shall be submitted to the Employer for approval.

The nameplates of the apparatus shall include, at least, the information listed below, together with any other relevant information specified in the applicable standards:

- a) A concise descriptive title of the equipment
- b) Rating and circuit diagram reference numbers
- c) Manufacturer's name, trade-mark, model type, serial number
- d) Instruction book number
- e) Year of manufacture
- f) Total weight (for capacitor racks indicate weight, for capacitors indicate quantity of liquid)
- g) Special instructions, if any, about storage, transportation, handling etc.

Each measuring instrument and meter shall be prominently marked with the quantity measured e.g. kV, A, MW etc. All relays and other devices shall be clearly marked with manufacturer's name, manufacturer's type, serial number and electrical rating data.

Danger plates and plates for phase colours shall be provided as per requirement. The Supplier shall devise a system to designate equipment and sub-systems. The nameplates/ labels displaying these designations shall be installed at appropriate locations. Wherever motion/ flow of fluids are involved, plates/ marks showing direction of motion/ flow shall also be provided.

Each main and auxiliary item of substation is to have permanently attached to it in a conspicuous position a rating plate of non-corrosive material upon which is to be engraved manufacturer's name, year of manufacture, equipment name, type or serial number together with details of the loading conditions under which the item of substation in question has been designed to operate, and such diagram plates as may be required by the Purchaser. The rating plate of each equipment shall be according to IEC requirement.

All such nameplates, instruction plates, rating plates of transformers, reactors, CB, CT, CVT, SA, Isolators, C & R panels and PLCC equipments shall be bilingual with Hindi inscription first followed by English. Alternatively two separate plates one with Hindi and the other with English inscriptions may be provided.



3.12 Provisions for Exposure to Hot and Humid Climate

Outdoor equipment supplied under the specification shall be suitable for service and storage under tropical conditions of high temperature, high humidity, heavy rainfall and environment favourable to the growth of fungi and mildew. The indoor equipments located in non-air conditioned areas shall also be of same type.

3.12.1 Space Heaters

The heaters shall be suitable for continuous operation at 240 V ac supply voltage & shall be connected to the supply through a fuse.

One or more heaters shall be provided, with thermostats or hygrostat, to prevent condensation in any compartment. The heaters shall be suitable to maintain the compartment temperature at approximately 10 deg. C, above the outside air temperature to prevent condensation.

Control cubicles installed in air-conditioned area need not be provided with space heaters. These cubicles shall, however, have space heaters in case of storage of cubicles for long duration.

3.12.2 Fungi Static Varnish

Besides the space heaters, special moisture and fungus resistant varnish shall be applied on parts which may be subjected or predisposed to the formation of fungi due to the presence or deposit of nutrient substances. The varnish shall not be applied to any surface of part where the treatment will interfere with the operation or performance of the equipment. Such surfaces or parts shall be protected against the application of the varnish.

3.12.3 Ventilation Opening

In order to ensure adequate ventilation, compartments shall have ventilation openings provided with fine wire mesh of brass or galvanized steel to prevent the entry of insects and to reduce to a minimum the entry of dirt and dust. Outdoor compartment openings shall be provided with shutter type blinds.

3.12.4 Tropicalisation

The service building and bay kiosk shall be air-conditioned whereas the valve halls and indoor DC yard at Agra shall have ventilation system with positive pressure. All equipments shall, however, be suitable for installation in a tropical monsoon area having hot, humid climate and dry & dusty seasons with ambient conditions as specified. All control wiring, equipment and accessories shall be protected against fungus growth, condensation, vermin and other harmful effects due to a tropical environment.

3.13 Painting and finishing of metal surfaces

All sheet steel work shall be phosphated in accordance with the IS:6005 "Code of practice for phos-



**±800KV, 6000MW, HVDC MULTI-TERMINAL NER/ER – NRWR
INTERCONNECTOR-I PROJECT**

**General Technical Requirements- Section 3
Doc. No. : TB-343-316-000 Rev. 02**

phating iron and steel".

Oil, grease, dirt and swarf shall be thoroughly removed by emulsion cleaning.

Rust and scale shall be removed by pickling with dilute acid followed by washing with running water rinsing with a slightly alkaline hot water and drying.

After phosphating, thorough rinsing shall be carried out with clean water followed by final rinsing with dilute dichromate solution and oven drying.

The phosphate coating shall be sealed with application of two coats of ready mixed, stoved type zinc chromate primer. The first coat may be "flash dried" while the second coat shall be stoved.

After application of the primer, two coats of finishing synthetic enamel paint shall be applied, each coat followed by stoving. The second finishing coat shall be applied after inspection of first coat of painting. The exterior colour of paint shall be of a slightly different shade to enable inspection of the painting.

A small quantity of finished paint shall be supplied for minor touching up required at site after installation of the panels.

In case the Supplier proposes to follow his own standard surface finish and protection procedures any other established painting procedures, like electrostatic painting etc., the procedure shall be submitted along with the Bids for Purchaser's review & approval. The Supplier shall use procedures for painting approved by the Employer during detailed Engineering.

3.14 Hot Dip Galvanising

The minimum weight of the zinc coating shall be 615 gm/ sq.m and minimum thickness of coating shall be 85 microns for all items thicker than 6 mm. For items less than 6 mm, requirements of coating thickness shall be as per relevant ASTM. For surfaces, which shall be embedded in concrete, the zinc coating shall be 900-gm/sq.m .

The galvanized surfaces shall consist of a continuous and uniform thick coating of zinc, firmly adhering to the steel. The finished surface shall be clean and smooth and shall be free from defects like discoloured patches, bare spots, unevenness of coating, which is loosely attached to the steel globules, spiky deposits, blistered surfaces, flaking or peeling off, etc. The presence of any of these defects noticed on visual inspection shall render the material liable to rejection.

After galvanizing, no drilling or welding shall be performed on the galvanized parts of the equipment except the nuts may be rethreaded after galvanizing. Sodium dichromate treatment shall be provided to avoid formation of white rust after hot dip galvanization.

The galvanized steel shall be subjected to six one-minute dips in copper sulphate solution as per IS-2633.

Sharp edges with radii less than 2.5 mm shall be able to withstand four immersions of the Standard Preece test. All other coatings shall withstand six immersions.



The following galvanizing tests should be performed as per relevant Indian Standards.

- Coating thickness
- Uniformity of zinc
- Adhesion test
- Mass of zinc coating

3.15 Control cabinets, junction boxes, terminal boxes & marshalling boxes for equipment

All types of boxes, cabinets etc. shall generally conform to & be tested in accordance with IS-5039/IS-8623, IEC-60439, as applicable, and the clauses given below:

1. Enclosure for control cabinets, junction boxes, Marshalling boxes & terminal boxes shall be made of stainless steel or aluminium and shall be dust, water and vermin proof. The box shall be properly braced to prevent wobbling. There shall be sufficient reinforcement to provide level surfaces, resistance to vibrations and rigidity during transportation and installation.
2. The enclosures of the control cabinets, junction boxes, terminal boxes & marshalling boxes located outdoor shall provide a degree of protection of not less than IP 55 as per IS-13947:Part I One control cabinet, junction box, terminal box & marshalling box of each type shall be tested for the same.
3. Cabinets/boxes shall be freestanding floor-mounting type, wall mounting type, or pedestal mounting type as required. Equipments such as telephone exchange, Public address systems etc shall be kept inside cubicles.
4. Cabinets/ boxes shall be provided with double-hinged doors with padlocking arrangements. The distance between two hinges shall be adequate to ensure uniform sealing pressure against atmosphere. The quality of the gasket shall be such that it does not get damaged/cracked during the operation of the equipment.
5. All doors, removable covers and plates shall be gasketed all around with suitably profiled EPDM gaskets. The gasket shall be tested in accordance with approved Quality Plan. Ventilating louvers, if provided, shall have screen and filters. The screen shall be fine wire mesh made of brass.
6. All boxes/cabinets shall be designed for the entry of cables from the bottom by means of weatherproof and dust-proof connections. Boxes and cabinets shall be designed with generous clearances to avoid interference between the wiring entering from below and any terminal blocks or accessories mounted within the box or cabinet. A suitable horizontal cable gland plate positioned at least 150 mm above the base of the marshalling kiosk/box shall be provided for this purpose along with the proper blanking plates. Necessary number of cable glands shall be supplied and fitted on this gland plate. The gland shall project at least 25mm above gland plate to prevent entry of moisture in cable crutch. Gland plate shall have provision for some future glands to be provided later, if required. The glands shall be dust proof, screw on & double compression type and made of brass. The gland shall have provision for securing armour of the cable separately and shall be provided with earthing tag. The glands shall conform to BS: 6121 and shall be nickel-plated.



**±800KV, 6000MW, HVDC MULTI-TERMINAL NER/ER – NR/WR
INTERCONNECTOR-I PROJECT**

**General Technical Requirements- Section 3
Doc. No. : TB-343-316-000 Rev. 02**

Boxes / cabinets to be located inside a building in a non air- conditioned area may be designed for the entry of cables from the bottom or from the top.

The (415 V) secondary distribution system shall be made up of 415 V power centres serving the different classes of loads either directly or thorough motor control centres. Two separate 415 V power centres, one for each pole shall be provided. The two sections of power control centres (PCC) feeding the duplicated loads, like pumps, fans, heat exchangers, etc. as well as the duplicated supply circuits shall be physically independent, permanently energized and fed by different sections of the 415 V power centres. A tie circuit breaker, shall be provided between the two sections of above PCC feeding the duplicated loads, in order that when one section of PCC is out for maintenance or fault, the other section can supply all the loads.

The motor control centres (MCC) shall be provided in accordance with the relevant Standards. The MCC shall be located near the supplied loads. The incomers of the MCC shall be individually interlocked to prevent paralleling of two different power centre buses. The 240 V loads shall be supplied by 240 V panels located in the MCC or outside the MCC where it is required.

415 V MCCs for valve cooling, pump house, valve hall ventilation system, air-conditioning system etc. shall be arranged as per figure given below:

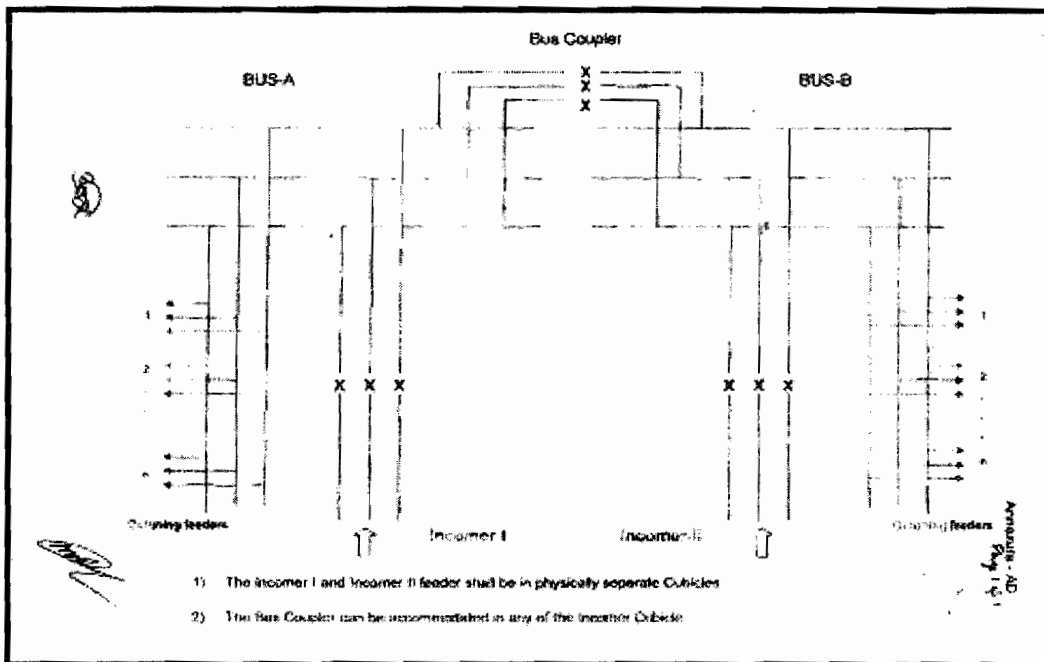

25% spare feeders, but not less than one of each type and rating shall be provided on 415V switchgears, power centres and motor, control centres as well as on all dc distribution boards

The AC & DC Distribution Boards shall have a fixed type, floor-mounted, free-standing, metal enclosed, with compartmentalised construction. They shall have separate Busbar chamber and cable alleys. All equipment for each feeder (i.e. main switch, HRC fuses, neutral link and cable terminals) shall be housed in a fully enclosed compartment with a separate hinged door,



**±800KV, 6000MW, HVDC MULTI-TERMINAL NER/ER – NR/WR
INTERCONNECTOR-I PROJECT**

**General Technical Requirements- Section 3
Doc. No. : TB-343-316-000 Rev. 02**

such that fuse replacement, cable termination/replacement etc. are possible with complete safety, even if the Busbar and adjacent feeders are live. The connections from Busbar to the main switch shall be fully insulated/shrouded, and securely bolted. The partition between the feeder compartment and cable alley shall be non-metallic and shall be of such construction as to allow cable cores with lugs to be easily inserted in the feeder compartment for termination. Cable alley shall have no exposed live parts, and shall have no communication with Busbar chamber. The main switch shall be operated from outside, and shall be interlocked with the compartment door such that the latter can be opened only when the switch is OFF. However, it shall be possible to defeat this interlock and open and close the door with the switch ON. Busbar chamber shall be completely enclosed with metallic partitions. Bolted covers shall be provided for access to horizontal and vertical Busbar and all joints, for repair and maintenance, which shall be feasible without disturbing the feeder compartment. Cable alley door shall preferably be hinged. The main switch shall have the facility of being pad-locked in both ON and OFF positions. The switch handle shall clearly indicate the position of main switch. The Supplier shall furnish suitable plugs to cover the cable openings in the partition between feeder compartment and cable alley, for at least 50% of the total number of feeders. The distribution boards shall have a degree of protection of at least IP52 as per IS-13947:Part I.

All 415V switchgear (circuit breaker boards) shall be of single front type, with fully draw out circuit breakers, which can be drawn out without having to unscrew any connections. The circuit breakers shall be mounted on rollers and guides for smooth movement between SERVICE, TEST and ISOLATED positions and for withdrawal from the Switchboard. Testing of the breaker shall be possible in the TEST position. Unless kept in OFF position it shall not be possible to withdraw the modules from service position or rack them into service position.

All outgoing feeders in distribution boards shall be through MCBs/MCCBs.

Circuit breakers shall be three pole air break horizontal draw out type and shall have inherent fault making and breaking capacities as specified. The circuit breakers which meet specified parameter only after provision of releases or any other devices shall not be acceptable.

All circuit breakers shall be provided at least with 4 NO and 4 NC potentially free auxiliary contacts. These contacts shall be in addition to those required for internal mechanism of the breaker. Separate limit switches each having required number of contacts shall be provided in both 'SERVICE' & 'TEST' position of the breaker.

Control cabinets, junction boxes, Marshalling boxes and terminal boxes shall be made of sheet steel or aluminium enclosure. Sheet steel used shall be at least 2.0-mm thick cold rolled or 2.5 mm hot rolled. In case of aluminium enclosed box the thickness of aluminium shall be such that it provides adequate rigidity and long life as comparable with sheet steel of specified thickness.

7. Earthing

The provision for earthing shall be generally as per requirements given in Clause 3.16.2

8. Tests

- a) The Marshalling Kiosks shall be subject to routine tests as per IS: 5039



**±800KV, 6000MW, HVDC MULTI-TERMINAL NER/ER – NR/WR
INTERCONNECTOR-I PROJECT**

**General Technical Requirements- Section 3
Doc. No. : TB-343-316-000 Rev. 02**

b) The following routine tests shall also be conducted:

- i) Check for wiring
- ii) Visual and dimension check

Marshalling kiosk shall be provided with danger plate and a diagram showing the numbering/ connection/ ferruling by pasting the same on the inside of the door.

Marshalling kiosk shall also be provided with incoming MCB and one 15 Amp interlocked switched socket in addition to the MCB required.

3.16 Indoor control cubicles

The control panel, cubicles and desks shall be in accordance with the relevant IEC standards and shall be installed in air-conditioned space. Indoor electronic cubicles shall not generally require fans for cooling in order to operate successfully and correctly at the maximum ambient temperature. However, if it is absolutely necessary to install fans etc. in cubicles for cooling then these shall be driven by the same dc supply as used for control, and necessary redundancy, failure alarm etc. shall be incorporated. Louvers in the doors and side panels shall be permitted, if required.

The control and relay panels shall be suitable for numerical relays of modular type mounted in standard 19 inch racks located on the vertical front panel with rear doors for access or located on the front doors for front access type panels. Panels Cubicles shall be completely metal enclosed and shall be dust, moisture and vermin proof. The enclosure shall provide a degree of protection not less than IP 32 in accordance with IS-13947:Part I for cubicles located in air-conditioned areas. IP 31 may also be acceptable for these areas if the layout is arranged such that there is no possibility at all of any liquid entering the area. However, for ventilation reasons the cubicles may be provided with a ventilation hood at the top with a protection class of IP21.

Panels shall be free standing, floor mounting type and shall comprise structural frames enclosed completely with specially selected smooth finished, cold rolled sheet steel of thickness not less than 2.5 mm for weight bearing members of the cubicles such as base frame, front sheet and door frames, and 1.5 mm for sides, door top and bottom portions. There shall be sufficient reinforcement to provide level surfaces, resistance to vibration and rigidity during transportation and installation. The cubicles shall be provided with lifting lugs.

All doors, removable covers and plates shall be gasketed all around with neoprene gaskets. Ventilation louvers, if provided, shall have screens and filters. The screens shall be made of either brass or GI wire mesh with a graduation of 1 mm or less.

Design, material selection and workmanship shall be such as to result in a neat appearance, inside and outside with no welds rivets or bolt heads apparent from outside, with all exterior surfaces true and smooth. All cubicles located in any room shall be matched in appearance.

The Supplier along with anchor bolts and necessary hardware for mounting the cubicles shall furnish metal sills in the form of metal channels properly drilled. Panels shall have an additional rolled channel plinth at the bottom with a smooth bearing surface. The panels shall be fixed on channels with intervening layers of anti-vibration strips made of shock absorbing material, which shall be



supplied by the Supplier.

Supplier's standard practice for control panels shall be acceptable to the Employer/Purchaser subject to approval during detailed engineering and meeting all functional requirements of the specification.

3.16.1 Mounting

All equipment on and in panels shall be mounted and completely wired to the terminal blocks ready for external connections. The equipment on front of panel shall be mounted flush. No equipment shall be mounted on the doors.

Equipment shall be mounted such that removal and replacement can be accomplished individually without interruption of service to adjacent devices and are readily accessible without use of special tools. Terminal marking on the equipment shall be clearly visible.

The Supplier shall carry out cut out, mounting and wiring of the free issue items supplied by others, which are to be mounted in his panel in accordance with the corresponding equipment manufacturer's drawings. Cut outs if any, provided for future mounting of equipment shall be properly blanked off with blanking plate.

The centre lines of switches, push buttons and indicating lamps shall be not less than 750mm from the bottom of the panel. The centre lines of relays, meters and recorders shall be not less than 450mm from the bottom of the panel

The centre lines of switches, push buttons and indicating lamps shall be matched to give a neat and uniform appearance. Like wise the top lines of all meters, relays and recorders etc. shall be matched.

No equipment shall be mounted on the doors.

At existing station, panels shall be matched with other panels in the control room in respect of dimensions, colour, appearance and arrangement of equipment (centre lines of switches, push buttons and other equipment) on the front of the panel.

3.16.2 Earthing

- 1) All panels shall be equipped with an earth bus securely fixed. Location of earth bus shall ensure no radiation interference for earth systems under various switching conditions of isolators and breakers. The material and the sizes of the bus bar shall be at least 25 X 6 sq. mm perforated copper with threaded holes at a gap of 50mm with a provision of bolts and nuts for connection with cable armours and mounted equipment etc for effective earthing. When several panels are mounted adjoining each other, the earth bus shall be made continuous and necessary connectors and clamps for this purpose shall be included in the scope of supply of Supplier. Provision shall be made for extending the earth bus bars to future adjoining panels on either side.
- 2) Provision shall be made on each bus bar of the end panels for connecting Substation earthing grid. Necessary terminal clamps and connectors for this purpose shall be included in the scope



**±800KV, 6000MW, HVDC MULTI-TERMINAL NER/ER – NR/WR
INTERCONNECTOR-I PROJECT**

**General Technical Requirements- Section 3
Doc. No. : TB-343-316-000 Rev. 02**

of supply of Supplier.

- 3) All metallic cases of relays, instruments and other panel mounted equipment including gland plate, shall be connected to the earth bus by copper wires of size not less than 2.5 sq. mm. The colour code of earthing wires shall be green.
- 4) Looping of earth connections, which would result in loss of earth connection to other devices when the loop is broken, shall not be permitted. Earthing may be done in such a manner that no circulating current shall flow in the panel.
- 5) VT and CT secondary neutral or common lead shall be earthed at one place only at the terminal blocks where they enter the panel. Such earthing shall be made through links so that earthing may be removed from one group without disturbing continuity of earthing system for other groups.
- 6) An electrostatic discharge point shall be provided in each panel connected to earth bus via 1 Mega Ohm resistor.

3.16.3 Instruments, meters and recorders

Only digital displays and systems shall be provided. The requirements in this section are applicable to auxiliary systems only. All instruments, meters and recorders shall be enclosed in dust proof, moisture resistant, black finished cases and shall be suitable for tropical use. They shall be calibrated to read directly the primary quantities. They shall be accurately adjusted and calibrated at the factory and shall have means of calibration, checking and adjustment at site.

3.16.4 Miscellaneous

- 1) The Supplier shall submit all type and routine test certificates to the Employer & Purchaser for approval before dispatching the equipment. Control and relay panels shall also be subjected to the following tests:
 - i) Mechanical operation test
 - ii) Verification of degree of protection as per IS-13947:Part I
 - iii) High voltage test
 - iv) Electrical control, Interlock and sequential operation test
 - v) Verification of wiring as per approved schematic.
- 2) Plug Point: 240V, Single phase 50Hz, AC socket with switch suitable to accept 5 Amps and 15 Amps pin round standard Indian plug, shall be provided in the interior of each cubicle with ON-OFF switch.
- 3) Interior Lighting: Each panel shall be provided with a CFL lighting fixture rated for 240 Volts, single phase, 50 Hz supply for the interior illumination of the panel controlled by the respective panel door switch. Adequate lighting shall also be provided for the corridor in Duplex panels.
- 4) MCB's: Each panel shall be provided with necessary arrangements for receiving, distributing and isolating of DC and AC supplies for various control, signalling, lighting and space heater circuits. The incoming and sub-circuits shall be separately provided with miniature circuit breakers (MCB).



- 5) Space Heater: Panels wherever required shall be provided with a space heater rated for 240V single phase, 50 Hz Ac supply for the internal heating of the panel to prevent condensation of moisture. The fittings shall be complete with thermostat and switch fuse /MCB unit.

3.16.5 Terminal blocks and wiring

All internal wiring to be connected to external equipment shall terminate on terminal blocks. Terminal blocks shall be 650 V grade and have 10 Amps. Continuous rating, moulded piece, complete with insulated barriers, stud type terminals, washers, nuts and lock nuts. Markings on the terminal blocks shall correspond to wire number and terminal numbers on the wiring diagrams. All terminal blocks shall have shrouding with transparent unbreakable material.

Disconnecting type terminal blocks for current transformer and voltage transformer secondary leads shall be provided. Also current transformer secondary leads shall be provided with short circuiting and earthing facilities.

Spare terminals for Employer's use for upgrading to 6000 MW shall be provided wherever required. In addition, at least 20% spare terminals shall be provided on each panel and these spare terminals shall be uniformly distributed on all terminal blocks.

The terminal blocks shall be suitable for connecting the conductors of external cable on each side.

Terminal blocks shall be of (at least) 650V grade and have 10 amps continuous rating. These shall be moulded, complete with insulated barriers, stud type terminals, complete with washers, nuts and lock nuts. Screw clamp, overall insulated, insertion type, rail mounted terminals can be used in place of stud terminals with locking type. The terminal blocks shall be of reputed make subject to Employer's acceptance.

Terminal block design shall include a white fibre marking strip with clear plastic, /clip-on terminal covers. Markings on the terminal strips shall correspond to wire numbers on the wiring diagrams.

Terminal blocks for current transformer and voltage transformer secondary leads shall be provided with test links and isolating facilities. The current transformer secondary leads shall also be provided with short-circuiting and earthing facilities.

The conducting part in contact with the cable shall preferably be tinned or silver-plated however; nickel-plated copper shall also be acceptable. Insulating barriers shall be provided between the terminal blocks.

Manufacturer's standard practice for internal wiring of cubicles shall be acceptable to the Employer. However all external cabling requirements shall be strictly as per TS.

The Supplier shall furnish all wire, conduits and terminals for the necessary inter-phase electrical connections (where applicable) as well as between phases and common terminal boxes or control cabinets.



**±800KV, 6000MW, HVDC MULTI-TERMINAL NER/ER – NR/WR
INTERCONNECTOR-I PROJECT**

**General Technical Requirements- Section 3
Doc. No. : TB-343-316-000 Rev. 02**

3.17 Degree of protection

The enclosures of the control cabinets, Junction boxes and Marshalling boxes, panels etc. to be installed as detailed here under:

The minimum requirements for panels are as follows:

Installed out door: IP- 55

Installed indoors in air-conditioned area: IP-32

Installed in covered area: IP-52

Installed indoors in non air-conditioned area where possibility of entry of water is limited: IP-41.

For LT Switchgear (AC & DC distribution Boards): IP-52.

The degree of protection shall be in accordance with IS:13947 (Part-I) / IEC-947 (Part-I) / IS 12063 / IEC 529. Type test report for degree of protection test, on each type of the box shall be submitted for approval

3.18 Welding and welders' qualifications

All welding shall be in accordance with the corresponding standards of the American Welding Society or the American Society of Mechanical Engineers. Welding shall comply with powergrid approved quality plan.

Other standards to determine the quality of welding processes and qualifications of welders may be considered, provided that sufficient information is first submitted for the approval of the Employer.

Prior to the start of fabrication, the Supplier shall submit to the Employer for approval, a description of each of the welding procedures which he proposes to adopt, together with certified copies of reports of the results from tests made in accordance with these procedures.

The Supplier shall be responsible for the quality of the work performed by his welding organization. All welding operators shall be assigned to the work, including for repair of castings, shall pass the required tests for qualification of welding procedures. The Employer reserves the right to witness the qualification tests for welding procedures and operators and the mechanical tests of the samples. If the Inspector so requires, the Supplier shall furnish to the Inspector certified copies of reports of the mechanical test results of the samples.

The Supplier shall bear all his own expenses in connection with the qualification tests. If the work of any operator at any time appears questionable, such operator shall be required to pass appropriate re-qualification tests as specified by the Inspector and at the expense of the Supplier.

Strict measures for quality control shall be exercised throughout the Equipment/Works. The Engineer may call for an adequate NDT test of the work of any operator, who, in his opinion, is not maintaining the required standard of workmanship. Should this NDT test prove defective, all work done by that operator, since his last test shall be tested at the Supplier's expense. If three or more of these tests prove defective, the operator shall be removed from the project.

A procedure for the repair of defects shall be submitted to the Employer for his approval prior to any



repairs being made.

3.19 Motors

All motors shall conform to IEC-60034-5 / IS Standard and with principal dimensions in accordance with IEC 60072-1 (1991), IEC 60072-2 (1990) and IEC 60072-3 (1994).

Motors rated 0.5 kW and above, and reversing motors, shall be rated 415 V, three phase, grounded neutral;

Motors rated below 0.5 kW shall be rated 240 V one phase;

All motors shall be designed to operate at full load dynamic conditions with a voltage range of variation of +10%, -20% and a frequency range variation of +5%,-10%. Motors shall also be designed to operate at 125% of the rated speed without mechanical damage, and to start with 80% of their rated voltage;

All motors shall be designed and rated for continuous operation at maximum ambient temperature of 50°C. The class of insulation shall be at least one class higher than used for defining the temperature rise of the motor;

Vertical motors rated 60 kW and above shall be provided with oil-lubricated self-cooled pivoted shoe-type thrust bearing. Vertical motors below 60 kW shall be provided with re-greasable anti-friction ball or roller bearings;

All anti-friction bearings shall be guaranteed to operate successfully for a minimum of 131,000 hours;

All bearings shall be quiet operating and statically and dynamically balanced;

All belts to be used shall be "V" type and designed for the maximum power to be transmitted and for the maximum speed. The selection of the "V" belt drive for any application shall also be based on the nature of the load and the type of the driving unit. Belts installed outdoors shall be suitably protected.

3.20 Conduits, pipes and accessories

The Supplier shall supply and install all rigid conduits, mild steel pipes, flexible conduits, hume pipes etc. including all necessary sundry materials, such as tees, elbows, check-nuts, bushings, reducers, enlargers, wooden plugs, coupling caps, nipples, gland sealing fittings, pull boxes etc. The size of the conduit/pipe shall be selected to limit the fill to a maximum of 40%. All conduits/pipes shall have their ends closed by caps until cables are pulled. After cables are pulled, the ends of conduits/pipes shall be sealed in an approved manner to prevent damage to threaded portions and entrance of moisture and foreign materials.

PVC conduits shall be of high impact, heavy gauge (at least class 2) conduit conforming to BS-4607.

The outer surface of the steel conduits shall be coated with hot-dip zinc and chromate conversion coatings. The inner surface shall have silicone epoxy ester coating for easy cable pulling. Mild steel



**±800KV, 6000MW, HVDC MULTI-TERMINAL NER/ER – NR/WR
INTERCONNECTOR-I PROJECT**

**General Technical Requirements- Section 3
Doc. No. : TB-343-316-000 Rev. 02**

pipes shall be hot-dip galvanized. All rigid conduits/pipes shall be of a reputed make.

The hume pipes and accessories shall be of reinforced concrete conforming to class NP2 of IS-458. All tests on hume pipes shall be conducted as per IS-458.

Flexible conduits shall be of heat-resistant lead coated steel, water-leak, fire and rust proof.

3.21 Packaging & protection

All the equipments shall be suitably protected, coated, covered or boxed and crated to prevent damage or deterioration during transit, handling and storage at Site till the time of erection. On request of the Purchaser, the Supplier shall also submit packing details/associated drawing for any equipment/material under his scope of supply, to facilitate the Purchaser to repack any equipment/material at a later date, in case the need arises. While packing all the materials, the limitation from the point of view of availability of Railway wagon sizes in India should be taken into account. The Supplier shall be responsible for any loss or damage during transportation, handling and storage due to improper packing. Any demurrage, warping and other such charges claimed by the transporters, railways etc. shall be to the account of the Supplier. Purchaser takes no responsibility of the availability of the wagons.

All coated surfaces shall be protected against abrasion, impact, discolouration and any other damages. All exposed threaded portions shall be suitably protected with either a metallic or a non-metallic protecting device. All ends of all valves and piping and conduit equipment connections shall be properly sealed with suitable devices to protect them from damage.

3.22 Auxiliary supply

The sub-station auxiliary supply is normally met through a system having the following parameters. The auxiliary power for station supply, including the equipment drive, cooling system of any equipment, air-conditioning, lighting etc shall be designed for the specified Parameters as under. The DC supply for the instrumentation and PLCC system shall also conform to the parameters as indicated in the following :

Table 24 - 3 Table for Auxiliary Supply

<i>Normal Voltage</i>	<i>Variation in Voltage</i>	<i>Frequency in Hz</i>	<i>Phases</i>	<i>Neutral Connection</i>
415V	± 10%	50 ± 5%	3 or 4 Wire	Solidly Earthed
240 V	± 10%	50 ± 5%	2 Wire	Solidly Earthed
220V	190 - 242	DC	-	Isolated 2 wire system DC unearthed system
48 V	41 - 52.8	DC	-	Isolated 2 wire system positive pole directly earthed

Combined variation of voltage and frequency shall be limited to ± 10%.

3.23 Lamps and sockets

Lamps



All incandescent lamps shall use a socket base as per IS-1258, except in the case of signal lamps.

Sockets

All sockets (convenience outlets) shall be suitable to accept both 5 Amp & 15 Amp pin round Standard Indian plugs. They shall be switched sockets with shutters. Degree of protection for outdoor switch sockets shall be IP55.

Hand Lamp

A 240 Volts, single Phase, 50 Hz AC plug point shall be provided in the interior of each cubicle with ON-OFF Switch for connection of hand lamps.

Switches and Fuses

Each panel shall be provided with necessary arrangements for receiving, distributing, isolating and fusing of DC and AC supplies for various control, signalling, lighting and space heater circuits. The incoming and sub-circuits shall be separately provided with switchfuse units. Selection of the main and Sub-circuit fuse ratings shall be such as to ensure selective clearance of sub-circuit faults. Potential circuits for relaying and metering shall be protected by HRC fuses. All fuses shall be of HRC cartridge type conforming to IS:9228 mounted on plug-in type fuse bases. Miniature circuit breakers with thermal protection and alarm contacts will also be accepted. All accessible live connection to fuse bases shall be adequately shrouded. Fuses shall have operation indicators for indicating blown fuse condition. Fuse carrier base shall have imprints of the fuse rating and voltage.

3.24 Availability spares

The Supplier shall supply the spare parts required to meet the specified guaranteed availability, and shall include such spare parts in the scope of supply. The detailed lists of spare parts to meet the guaranteed reliability & availability requirements shall be part of the contract documents. However if it is found during detailed engineering and/or Reliability & Availability prediction calculation that additional spares are required to meet target values, the same shall be made available by the Supplier without any additional cost to the Employer.

3.25 Commissioning spares

The Supplier shall supply additional spares which he expects to consume during installation, testing and commissioning of the systems. The quantity of these spares shall be decided based on his previous experience, such that site work shall not be hampered due to non-availability of these spares.

3.26 Tools & tackles

The Supplier shall also supply at each site one set of all special tools & tackles, testing equipment, handling equipment, etc. which are required by the Employer's maintenance staff to maintain the stations successfully.

3.27 Seismic force consideration



**±800KV, 6000MW, HVDC MULTI-TERMINAL NER/ER – NR/WR
INTERCONNECTOR-I PROJECT**

**General Technical Requirements- Section 3
Doc. No. : TB-343-316-000 Rev. 02**

All structures shall be designed for seismic forces in accordance with IS-1893.

The seismic design of electrical equipment shall be performed using estimated actual earth/ ground motion, defined by a response spectrum, rather than the equivalent loads specified in typical Building Codes.

For brittle materials like glass, porcelain and glass fibre reinforced plastic the maximum calculated load should not exceed 2/3 of the guaranteed minimum rupture (breaking) strength (safety factor 1.5) as defined by the manufacturer/supplier of the material used. The minimum rupture value is defined as $(X - 2 \cdot \sigma)$, where X is the mean value and 'sigma' is the standard deviation. For load combinations in porcelain insulators and similar the following expressions shall be fulfilled:

$$\{F_t / (F_t)_b\} + \{M_b / (M_b)_b\} < 2/3 \text{ and} \\ \{F_c / (F_c)_b\} + \{M_b / (M_b)_b\} < 2/3$$

Where:

F_t, F_c, M_b : calculated maximum tensile force; compressive force and bending respectively

(F), (F), (M)_b : corresponding guaranteed strength values

(For normal operating loads, a higher safety factor more than 1.5 shall be used, normally 2.0-2.5 depending on type of load as per recommendations of manufacturer).

Factor regarding importance of structures (I), as defined in IS-1893, shall not be taken less than 1.5.

3.28 Safety requirements

The requirements regarding provision of additional staircases and approachability as defined in the Fire Protection Manual, issued by the Regional Committees of the Tariff Advisory Committee shall be completely fulfilled. All other safety requirements shall be met as per the factories Act, TAC etc.



ANNEXURE-A
Corona and Radio Interference Voltage (RIV) Test

1. General

Unless otherwise stipulated, all equipment (except Auto Transformer & Shunt Reactor) together with its associated connectors, where applicable, shall be tested for external corona both by observing the voltage level for the extinction of visible corona under falling power frequency voltage and by measurement of radio interference voltage (RIV). The test procedure shall be reviewed for different equipment during submission of MQP/ITP.

2. Test Levels:

The test voltage levels for measurement of external RIV and for corona extinction voltage are listed under the relevant clauses of the specification.

3. Test Methods for RIV:

3.1 RIV tests shall be made according to measuring circuit as per International Special-Committee on Radio Interference (CISPR) Publication 16-1(1993) Part -1. The measuring circuit shall preferably be tuned to frequency with 10% of 0.5 Mhz but other frequencies in the range of 0.5 MHz to 2 MHz may be used, the measuring frequency being recorded. The results shall be in microvolts.

3.2 Alternatively, RIV tests shall be in accordance with NEMA standard Publication No. 107-1964, except otherwise noted herein.

3.3 In measurement of, RIV, temporary additional external corona shielding may be provided. In measurements of RIV only standard fittings of identical type supplied with the equipment and a simulation of the connections as used in the actual installation will be permitted in the vicinity within 3.5 meters of terminals.

3.4 Ambient noise shall be measured before and after each series of tests to ensure that there is no variation in ambient noise level. If variation is present, the lowest ambient noise level will form basis for the measurements. RIV levels shall be measured at increasing and decreasing voltages of 85%, 100%, 115% and 130% of the specified RIV test voltage for all equipment unless otherwise specified. The specified RIV test voltage for 400 kV, 220 kV is listed in the detailed specification together with maximum permissible RIV level in microvolts.

3.5 The metering instruments shall be as per CISPR recommendation or equivalent device so long as it has been used by other testing authorities.

3.6 The RIV measurement may be made with a noise meter. A calibration procedure of the frequency to which noise meter shall be tuned shall establish the ratio of voltage at the high voltage terminal to voltage read by noise level meter.

4. Test Methods for Visible Corona

The purpose of this test is to determine the corona extinction voltage of apparatus, connectors etc. The test shall be carried out in the same manner as RIV test described above with the exception that RIV measurements are not required during test and a search technique shall be used near the onset and extinction voltage, when the test voltage is raised and lowered to determine their precise values. The test voltage shall be raised to 130% of RIV test voltage and maintained there for five minutes. In case corona inception does not take place at 130 %, test



**±800KV, 6000MW, HVDC MULTI-TERMINAL NER/ER – NR/WR
INTERCONNECTOR-I PROJECT**

**General Technical Requirements- Section 3
Doc. No. : TB-343-316-000 Rev. 02**

shall be stopped, otherwise test shall be continued and the voltage will then be decreased slowly until all visible corona disappears. The procedure shall be repeated at least 4 times with corona inception and extinction voltage recorded each time. The corona extinction voltage for purposes of determining compliance with the specification shall be the lowest of the four values at which visible corona (negative or positive polarity) disappears. Photographs with laboratory in complete darkness shall be taken under test conditions, at all voltage steps i.e. 85%, 100%, 115% and 130%. Additional photographs shall be taken at corona inception and extinction voltages. At least two views shall be photographed in each case using Panchromatic film with an ASA daylight rating of 400 with an exposure of two minutes at a lens aperture of f/5.6 or equivalent. The photographic process shall be such that prints are available for inspection and comparison with conditions as determined from direct observation. Photographs shall be taken from above and below the level of connector so as to show corona on bushing, insulators and all parts of energised connectors. The photographs shall be framed such that test object essentially, fills the frame with no cut-off.

- 4.1 The test shall be recorded on each photograph. Additional photograph shall be taken from each camera position with lights on to show the relative position of test object to facilitate precise corona location from the photographic evidence.
- 4.2 In addition to photographs of the test object preferably four photographs shall be taken of the complete test assembly showing relative positions of all the test equipment and test objects. These four photographs shall be taken from four points equally spaced around the test arrangement to show its features from all sides. Drawings of the laboratory and test set up locations shall be provided to indicate camera positions and angles. The precise location of camera shall be approved by Purchaser's inspector, after determining the best camera locations by trial energisation of test object at a voltage which results in corona.
- 4.3 The test to determine the visible corona extinction voltage need not be carried out simultaneously with test to determine RIV levels.
- 4.4 However, both test shall be carried out with the same test set up and as little time duration between tests as possible. No modification on treatment of the sample between tests will be allowed. Simultaneous RIV and visible corona extinction voltage testing may be permitted at the discretion of Purchaser's inspector if, in his opinion, it will not prejudice other test.

5. Test Records:

In addition to the information previously mentioned and the requirements specified as per CISPR or NEMA 107-1964 the following data shall be included in test report:

- a) Background noise before and after test.
- b) Detailed procedure of application of test voltage.
- c) Measurements of RIV levels expressed in micro volts at each level.
- d) Results and observations with regard to location and type of interference sources detected at each step.
- e) Test voltage shall be recorded when measured RIV passes through 100 microvolts in each direction.
- f) Onset and extinction of visual corona for each of the four tests required shall be recorded.



4 ENCLOSURES TO SPECIFICATION

- 4.1 Architectural layout for Relay Control Buildings Type-1 & 2 (drg nos: 5517-3-83-002 & 102, Rev-1)

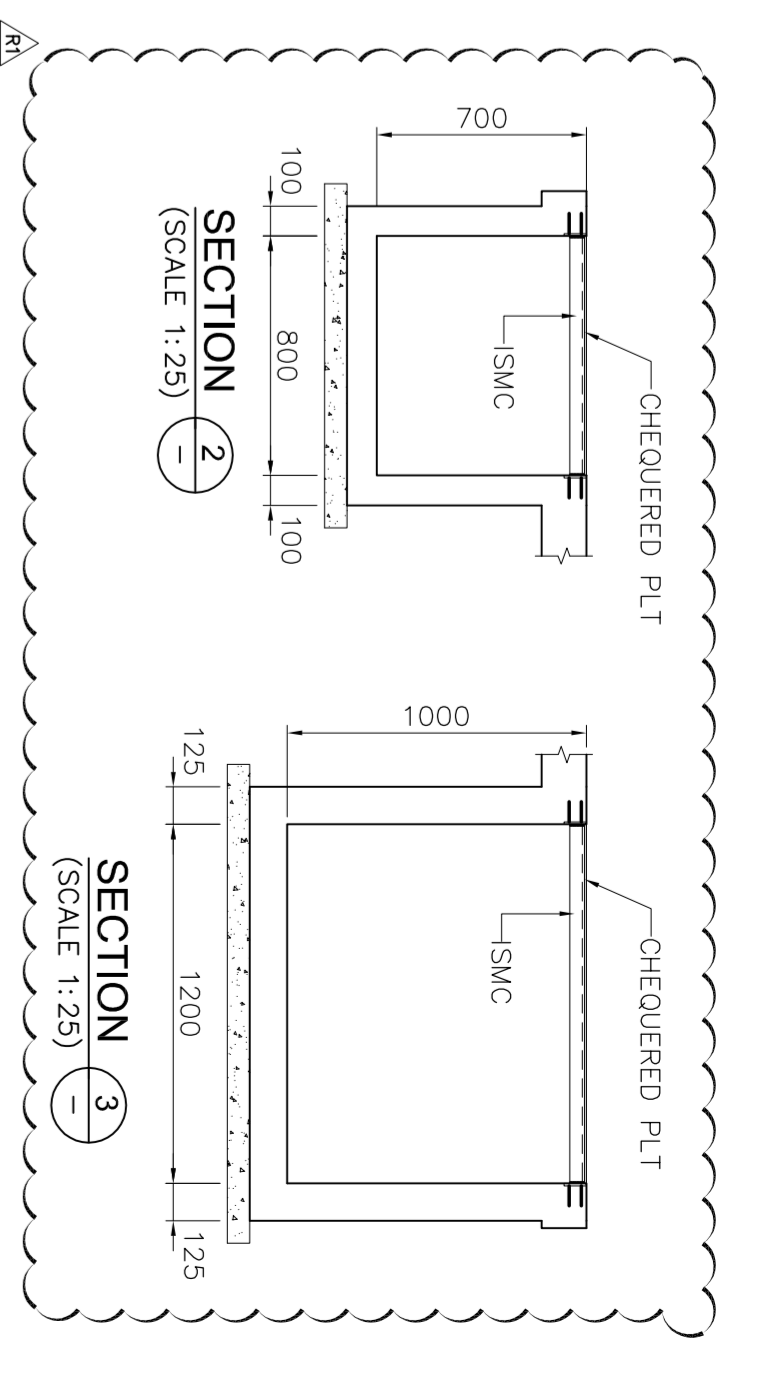
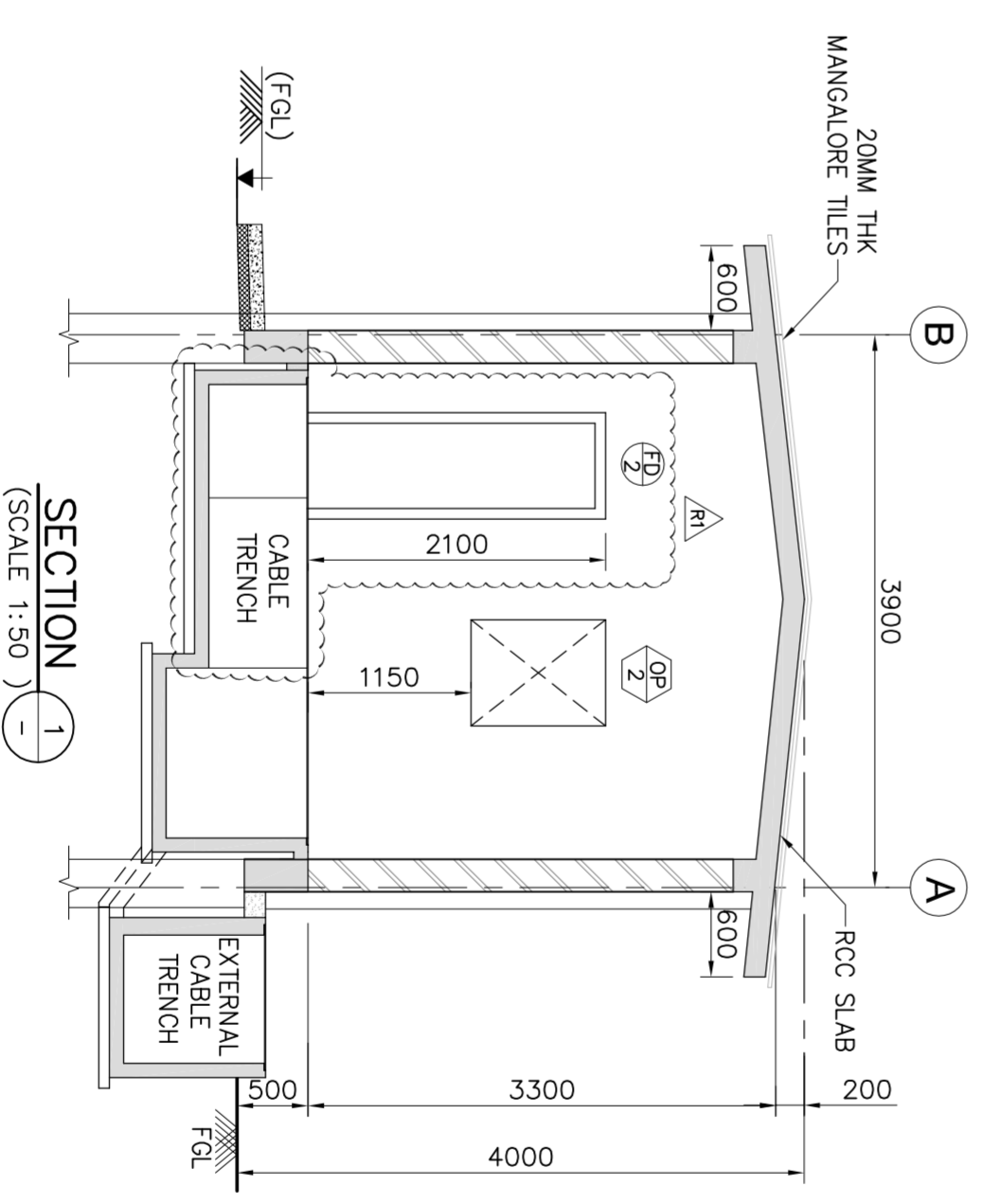
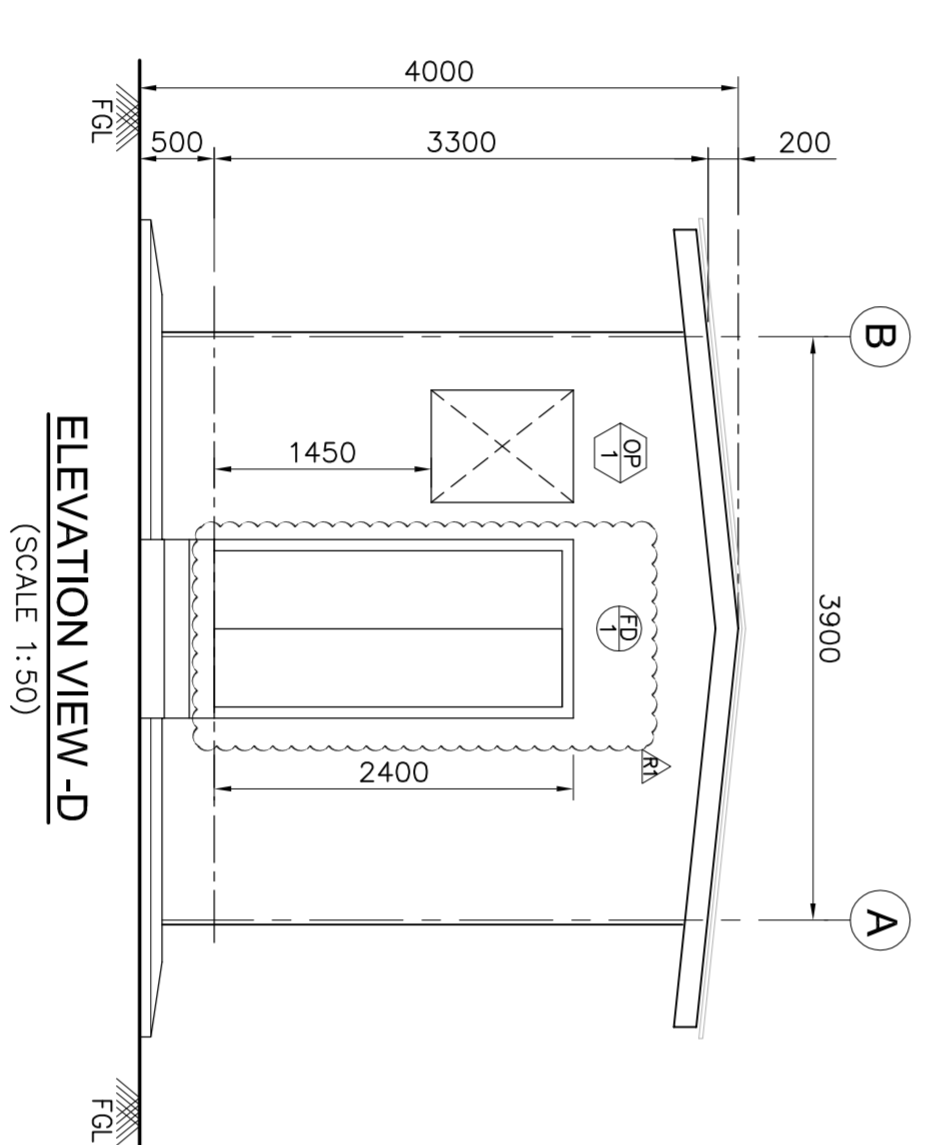
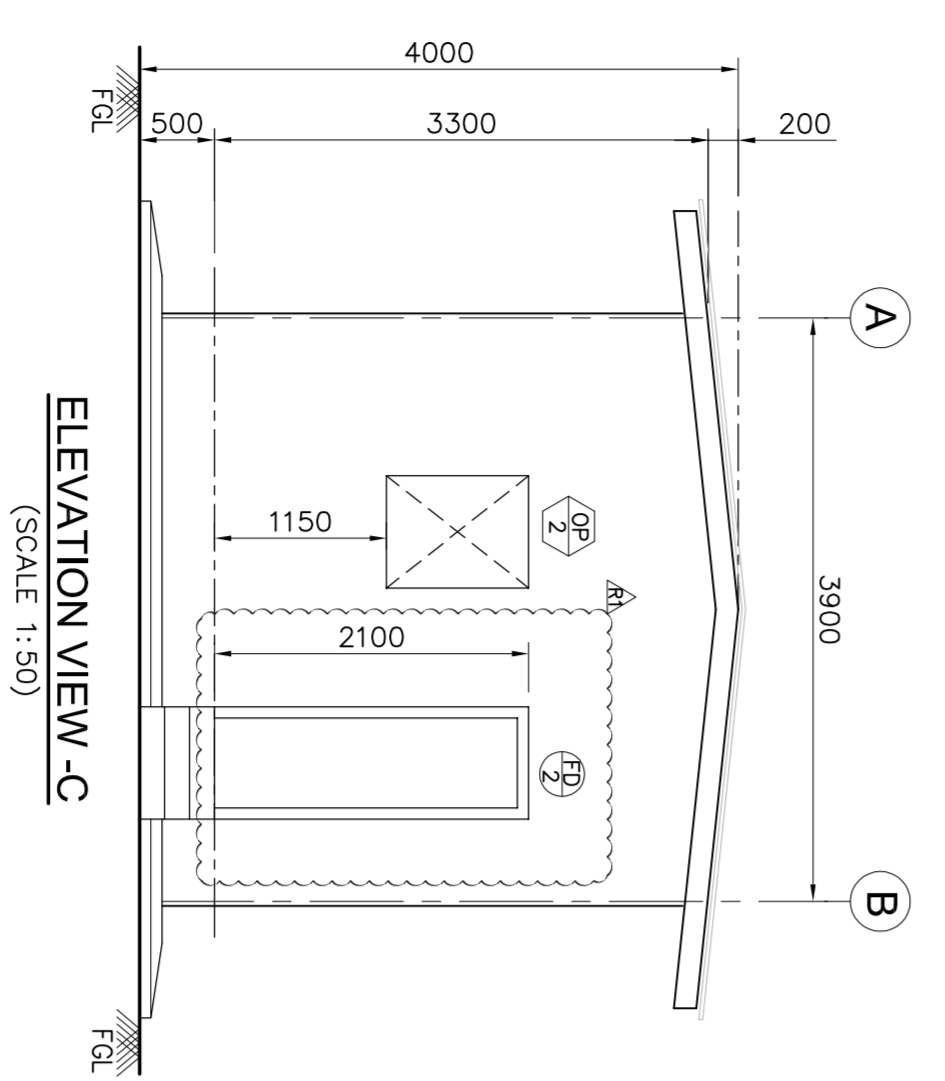
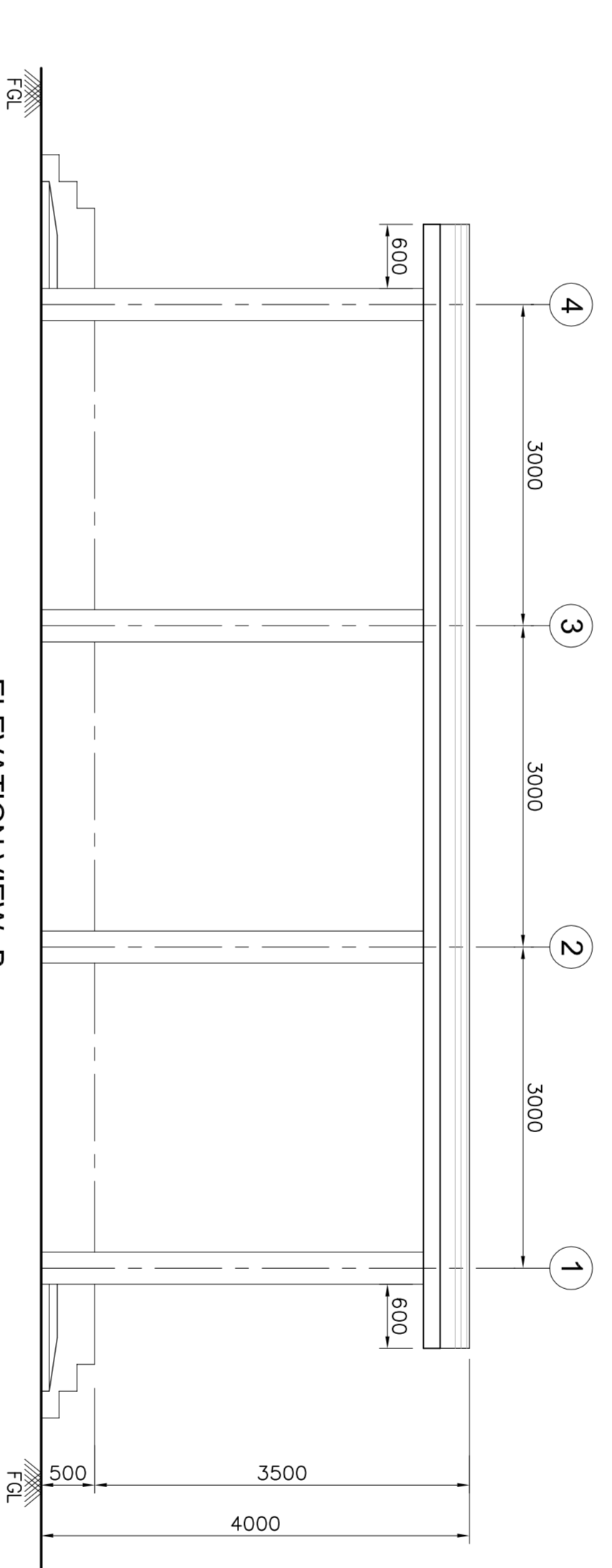
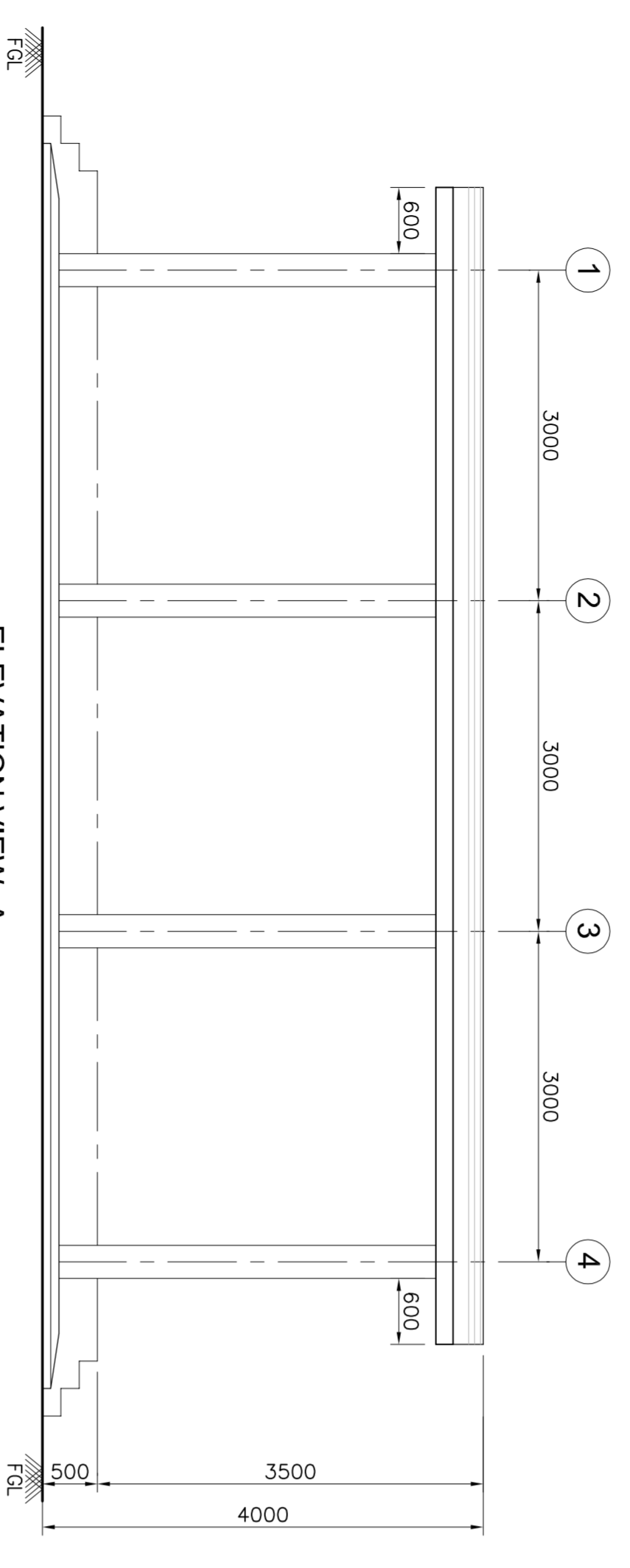
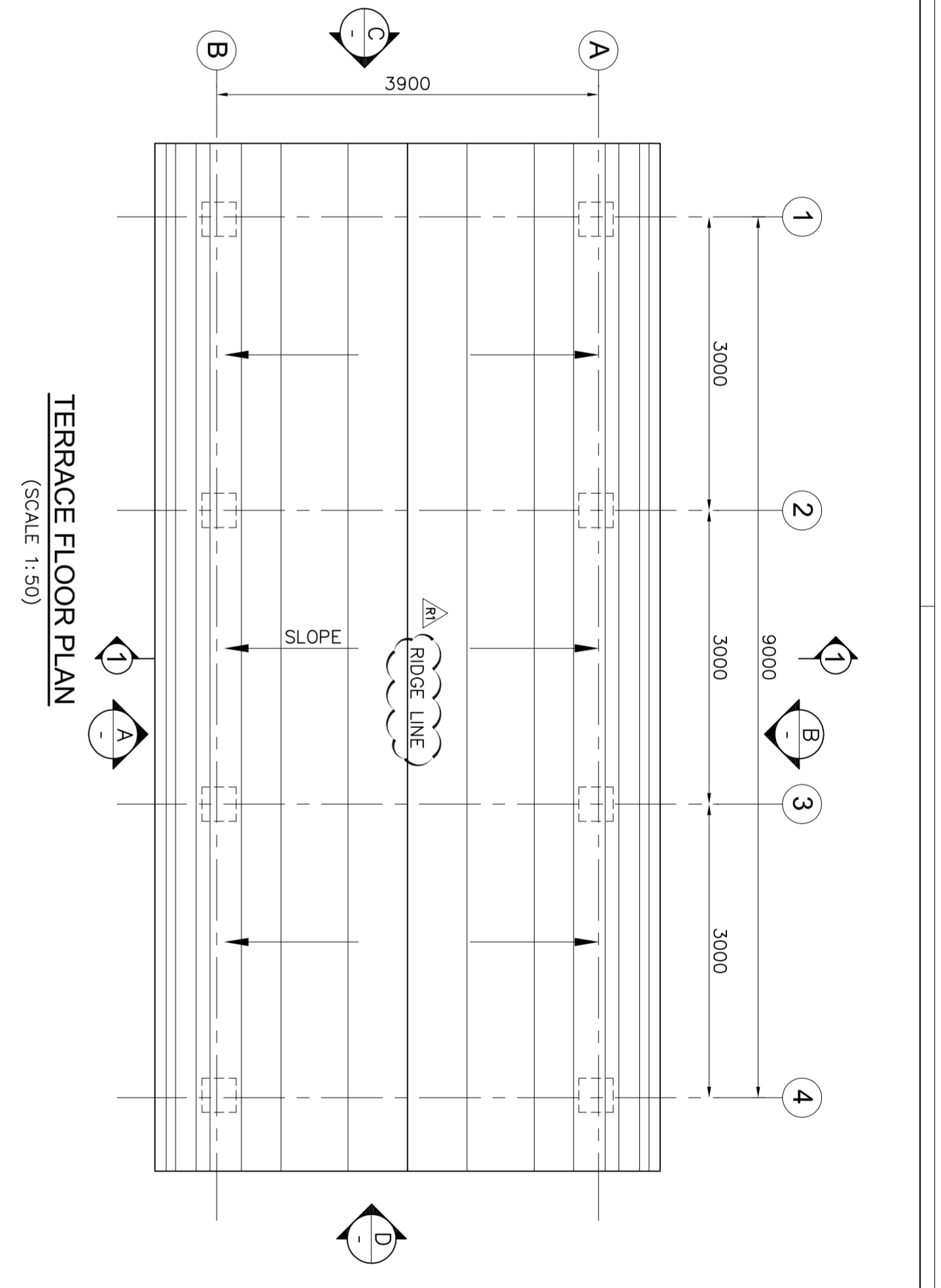
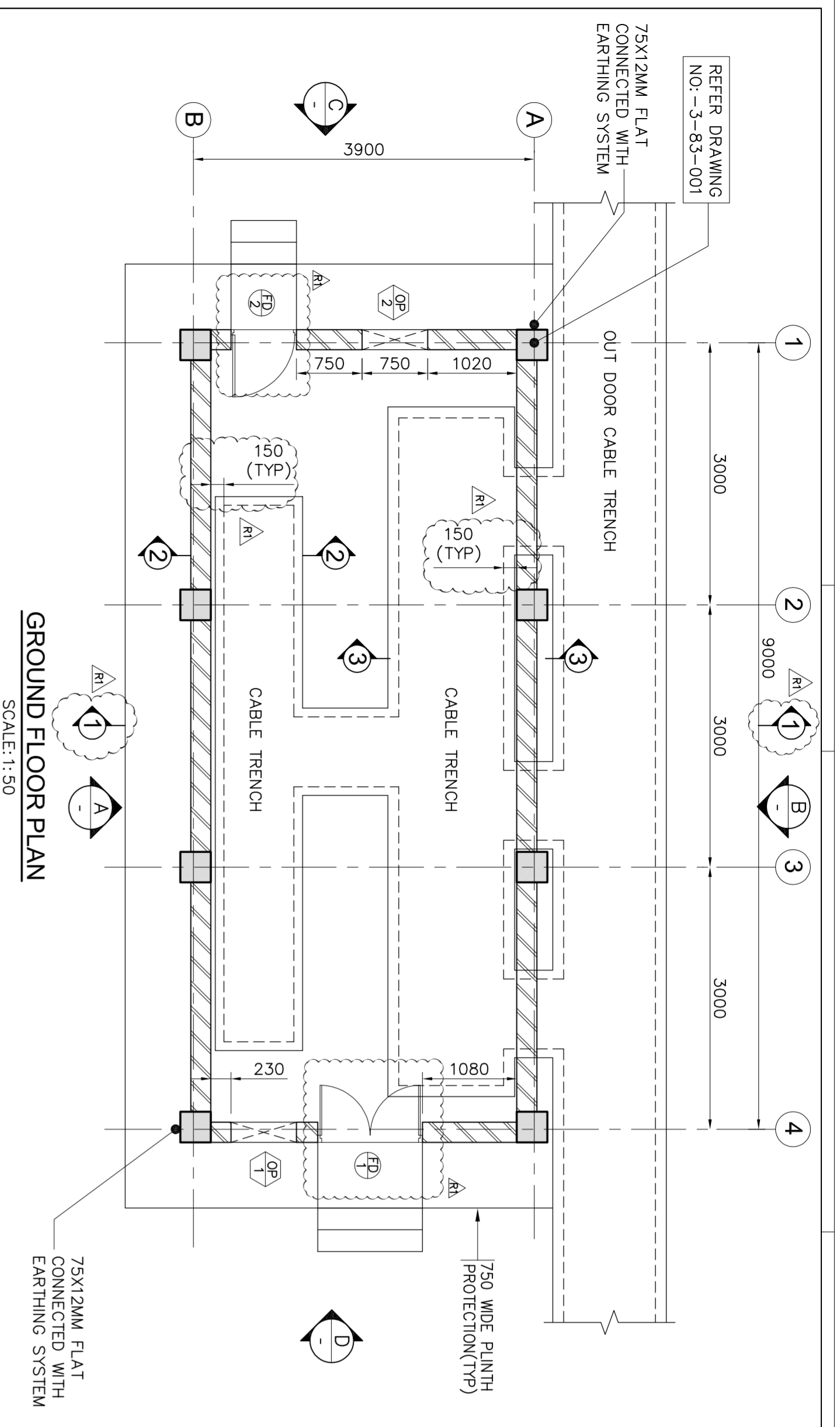

- NOTES:**
1. ALL DIMENSIONS ARE IN MILLIMETER AND LEVELS ARE IN METERS, UNO.
 2. THIS DRAWING SHALL BE READ IN CONJUNCTION WITH CONTRACT TERMS AND CONDITIONS AND SPECIFICATION.
 3. OPENING ARE PROVIDED FOR INSTALLATION OF ACS IN CASE ONE AC IS PROVIDED, OTHER OPENING SHALL BE CLOSED.
 4. 22G X 12MM CHICKEN WIRE MESH TO BE PROVIDED FOR ALL WALL, FLOORING AND ROOF. CHICKEN WIRE MESH SHALL BE CONNECTED WITH EARTHING SYSTEM THROUGH 75 X 12 MM FLAT FIXED ON DIAGONALLY OPPOSITE COLUMNS ON ITS OUTER SURFACE.
 5. OPENING SHALL BE SEALED PROPERLY (AFTER LAYING OF ALL CABLES) BY FIRE SEALING COMPOUND.

- LEGEND:**
- 230 THK BRICK WALL
 - FGI FINISHED GROUND LEVEL
 - FPL FINISHED FLOOR LEVEL
 - FPL FINISHED PAVING LEVEL
 - TYP TYPICAL
 - THK THICKNESS

- REFERENCE DRAWINGS**
- (CONSTRUCTION)
- 3-00-004 - GENERAL NOTES FOR MASONRY STRUCTURES
 - 3-83-001 - LAYOUT OF RELAY BUILDING
- (ENGINEERING)
- TB-0-343-316-115 - TRENCH LAYOUT HVDC - AGRA
 - 1JML100409-604-R2 - OVER ALL LAYOUT - AGRA
 - C-ENG-STD-PR-ARCH-3000 - R2 - ARCHITECTURAL DRAWING OF
- 3-00-010 - GENERAL NOTES - DOOR SCHEDULE
- 3-00-011 - GENERAL NOTES - WINDOW SCHEDULE

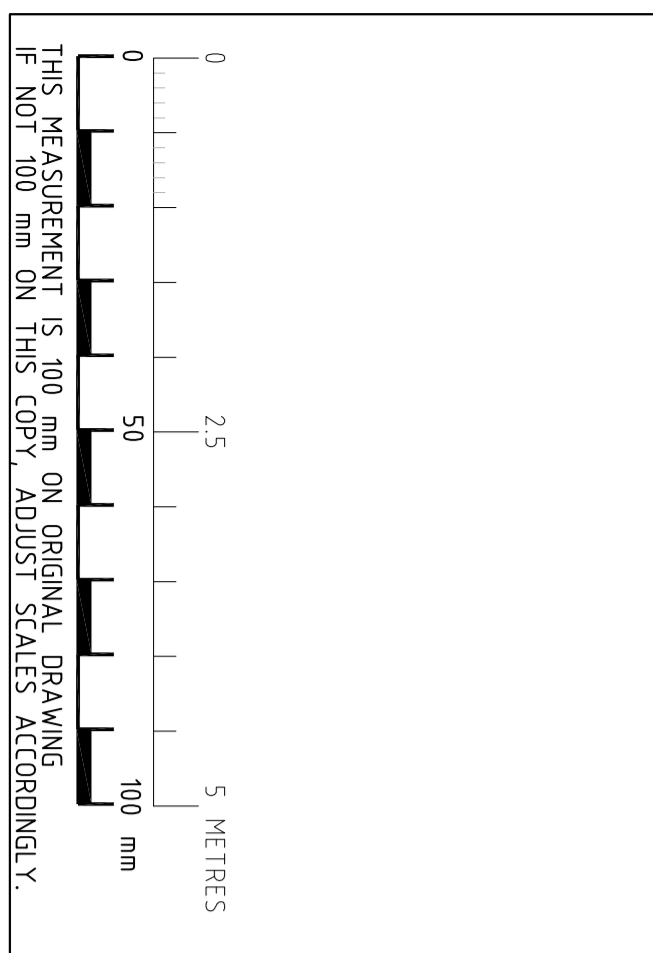

SCHEDULE OF JOINERY

SYMBOL	Nos.	MASONRY OPENING	REMARKS
1	01	1200	FIRE PROOF STEEL DOOR - DOUBLE SHUTTER
2	01	750	FIRE PROOF STEEL DOOR - SINGLE SHUTTER
3	01	750	OPENING FOR FIXING AIR CONDITIONS
4	01	950	OPENING FOR FIXING AIR CONDITIONS

FINISH SCHEDULE:

SERIAL NUMBER	ROOMS	FLOORS	INTERNAL WALLS	CEILING	EXTERNAL WALL
01	PANEL ROOM	POLISHED VITRIFIED TILES 600 X 600MM JOINT WITH WHITE CEMENT OVER CHICKEN WIRE MESH FIXED	CERAMIC TILES OVER 12MM PLASTER WITH CHICKEN WIRE MESH ON ENTIRE SURFACE OF THE WALL	6MM THK PLASTER OVER CHICKEN WIRE MESH PAINTED WITH OIL BOUND DISTEMPER	18MM THK PLASTER IN TWO LAYER OVER CHICKEN WIRE MESH AND PAINTED WITH NOVALUX EXTERIOR PAINT

NOTE: FOR EARLIER REVISION REFER
3-83-002-DATED 05.06.12

RI	REVISION AS PER COMMENTS	DATE	BY
RO	ISSUED FOR APPROVAL	06.06.12	ST
Rev'd	Revision	View	Mark

FOR APPROVAL

POWER GRID CORPORATION OF INDIA LIMITED
(A Government of India Enterprise)

± 800 kV 6000 MW HVDC Multi Terminal
NER/ER - NR/WR Interconnector-I

AGRA CONVERTER STATION RELAY BUILDING - (TYPE-1)
ARCHITECTURAL PLANS
SECTION AND ELEVATIONS

CONSULTANT
Civil and Building Works incl EL and Mech. Services.

ABIP
ABB AB
S-771 80 LUDVICA, Sweden
Telephone: +46 240 782000

BHEL
BHARAT HEAVY ELECTRICALS LTD.
TRANSMISSION PRODUCTS DIVISION

India
New Delhi
Bikaner
Agra
Mumbai

RI	REVISION AS PER COMMENTS	DATE	BY
RO	ISSUED FOR APPROVAL	06.06.12	ST
Rev'd	Revision	View	Mark

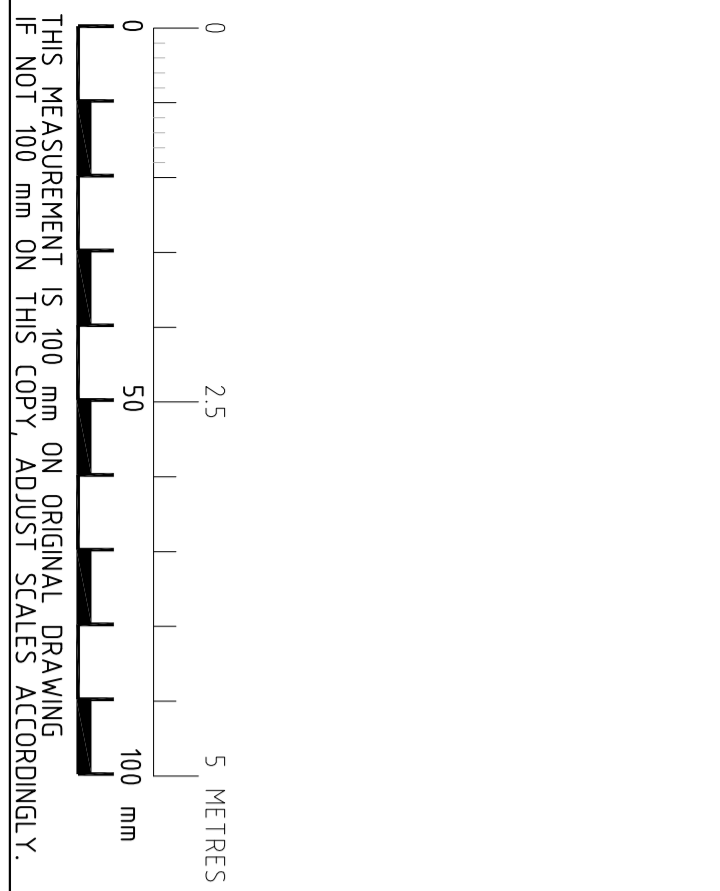
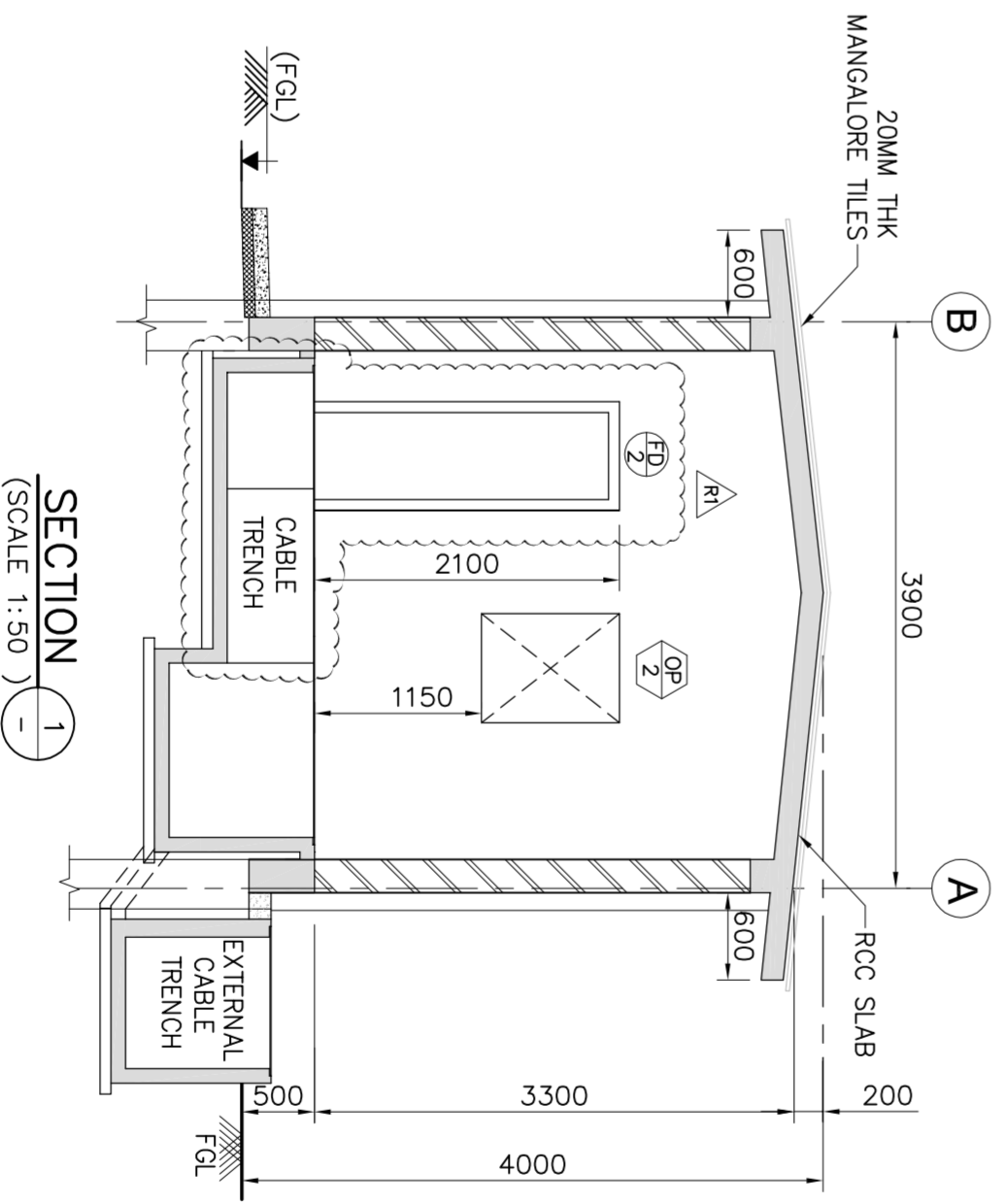
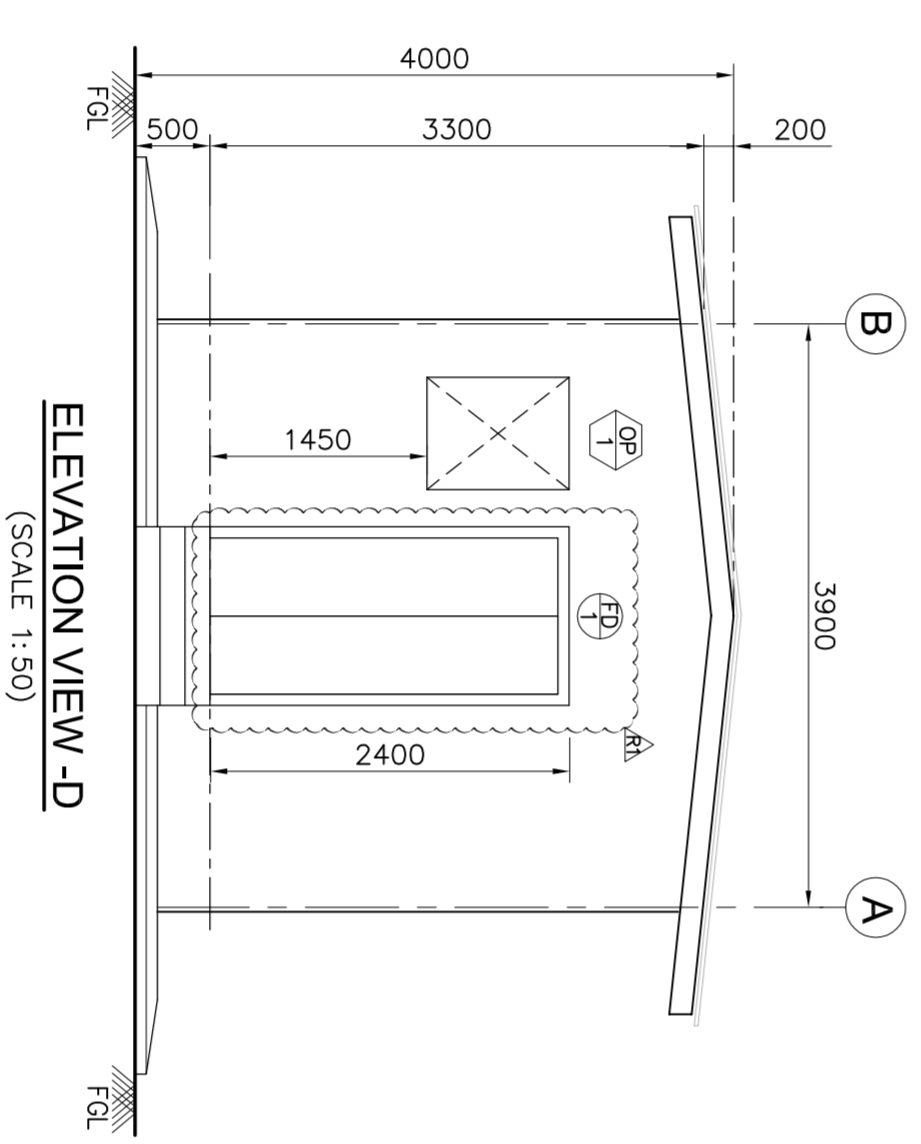
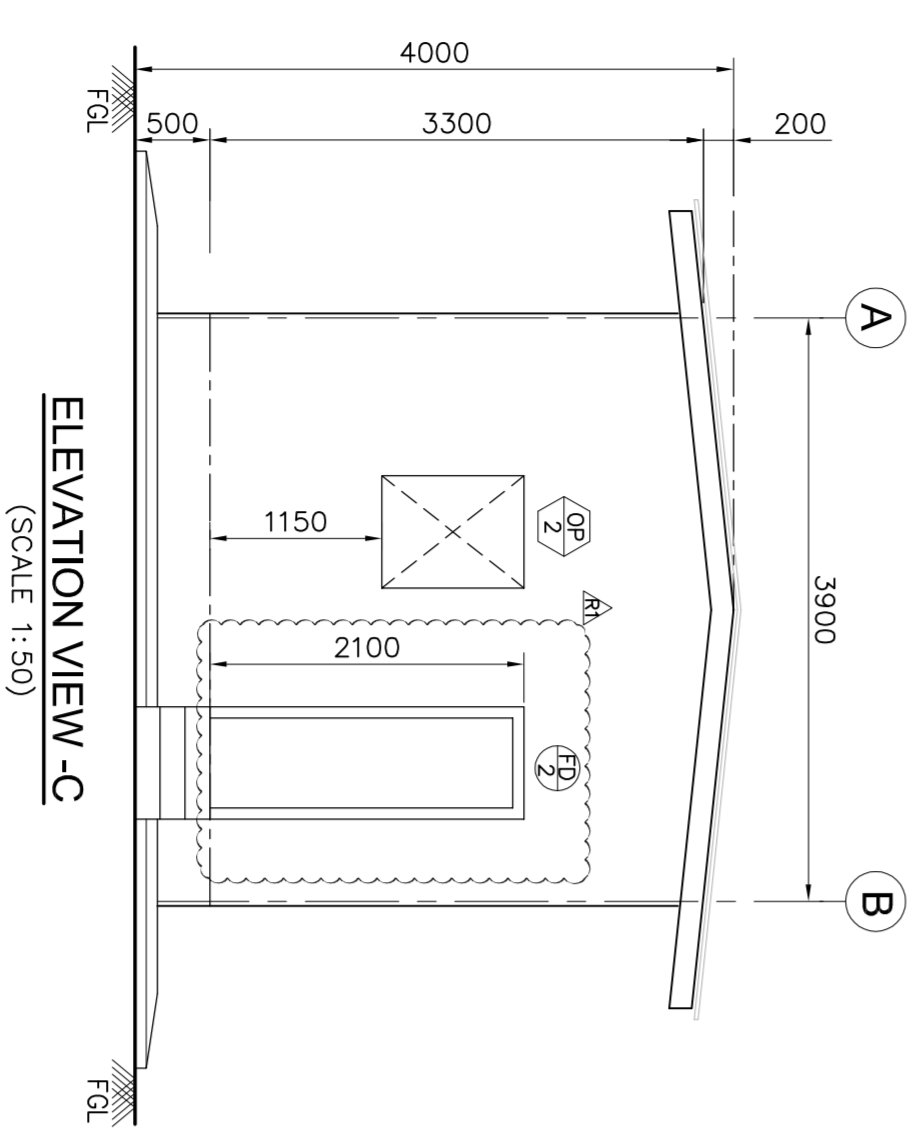
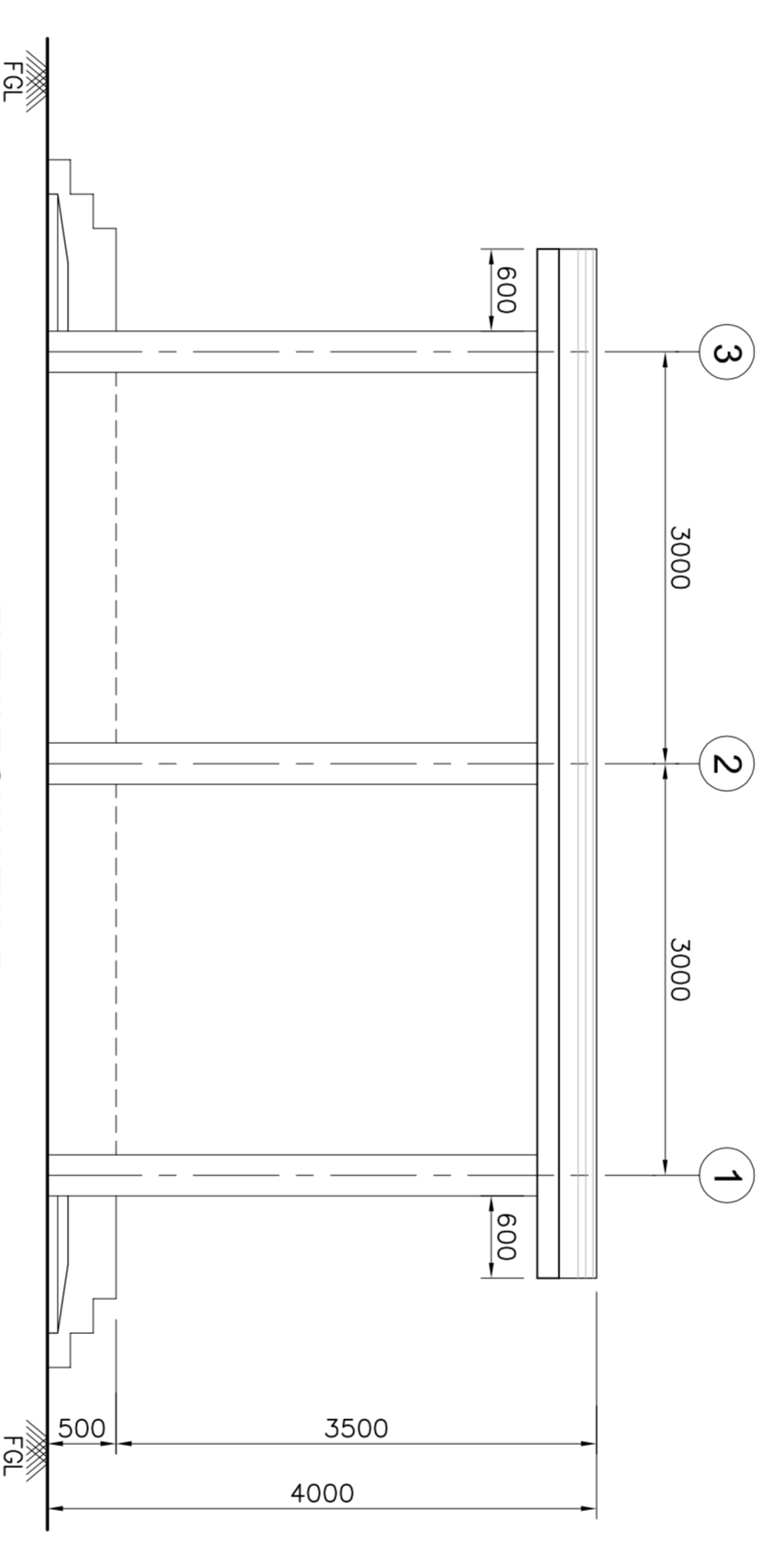
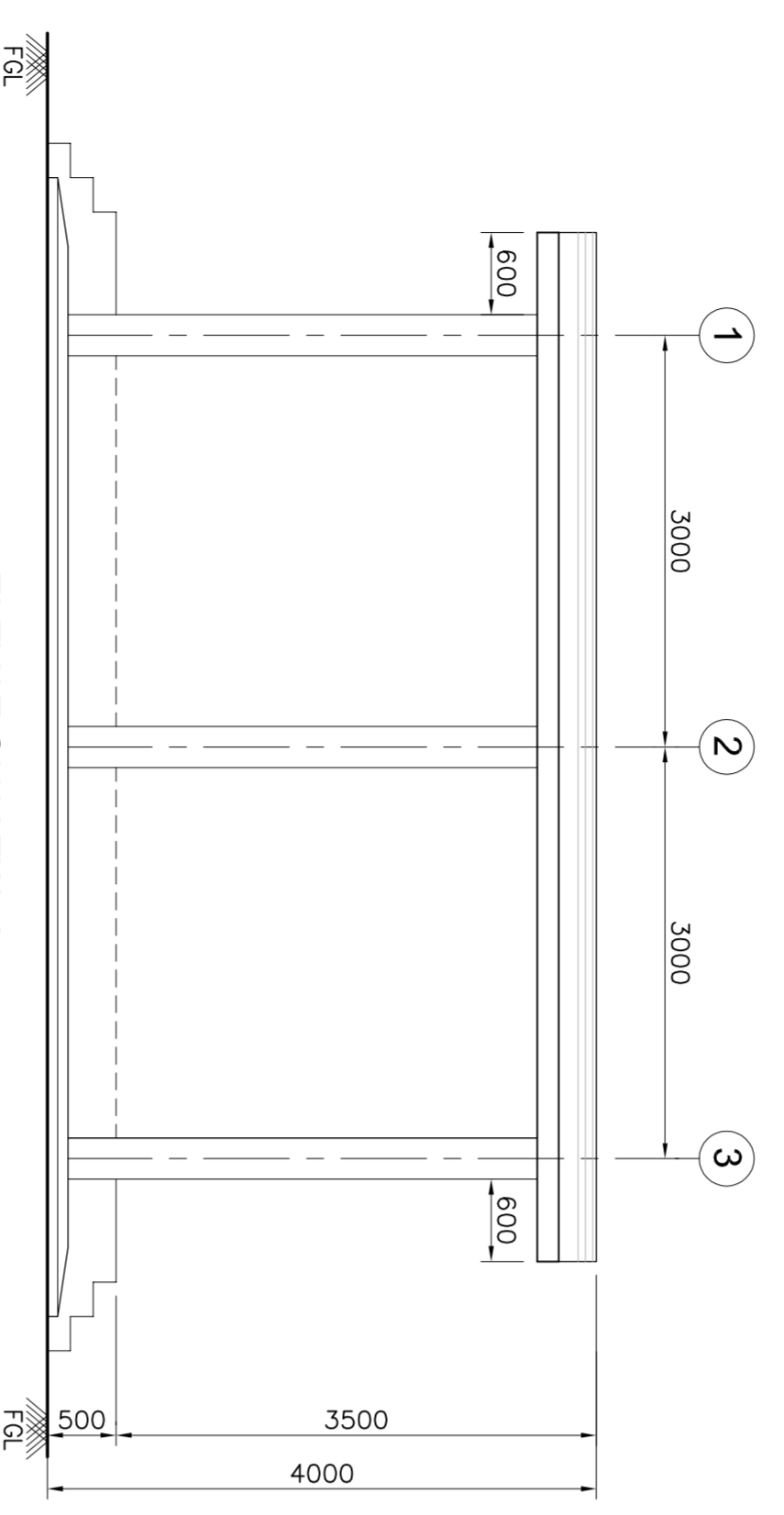
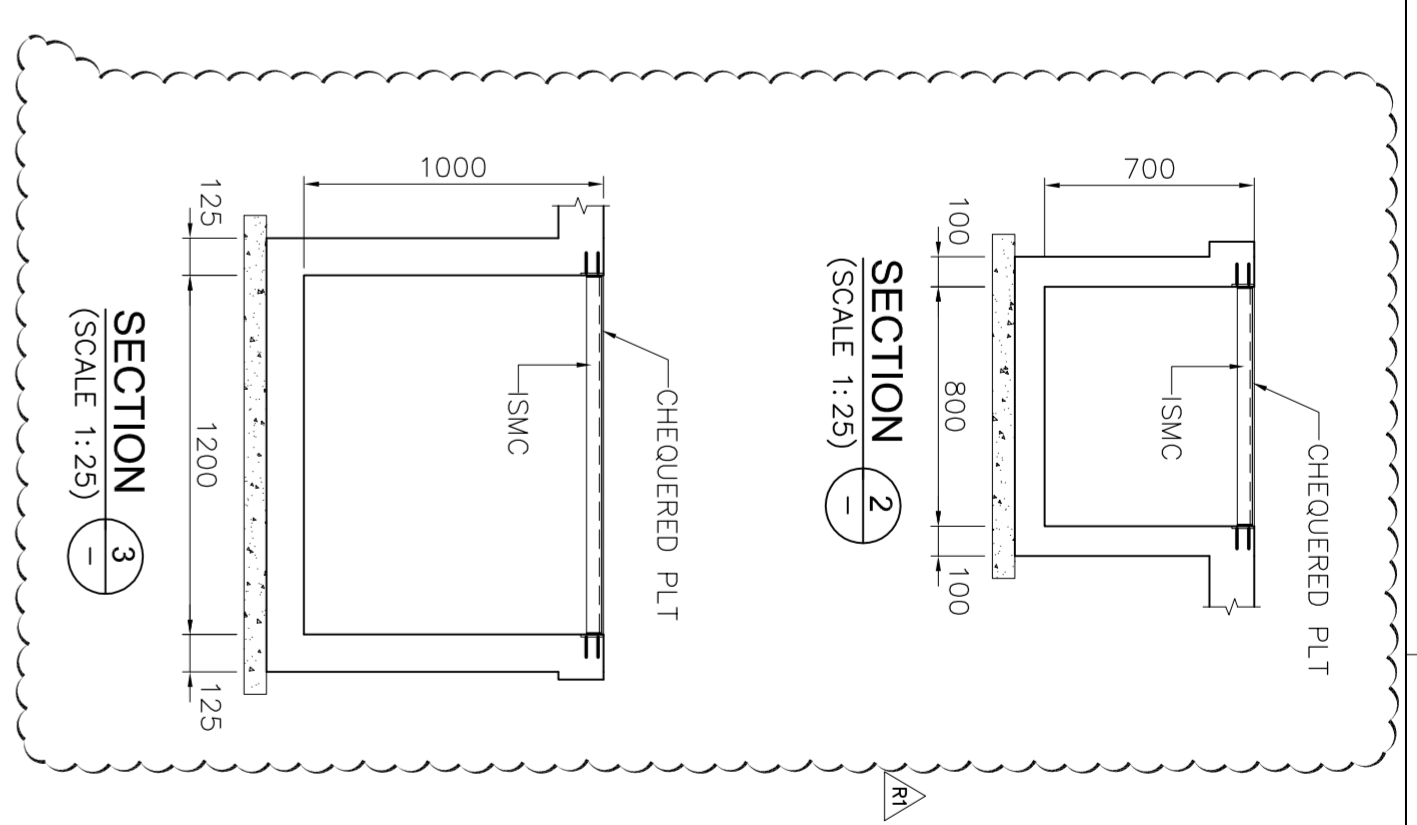
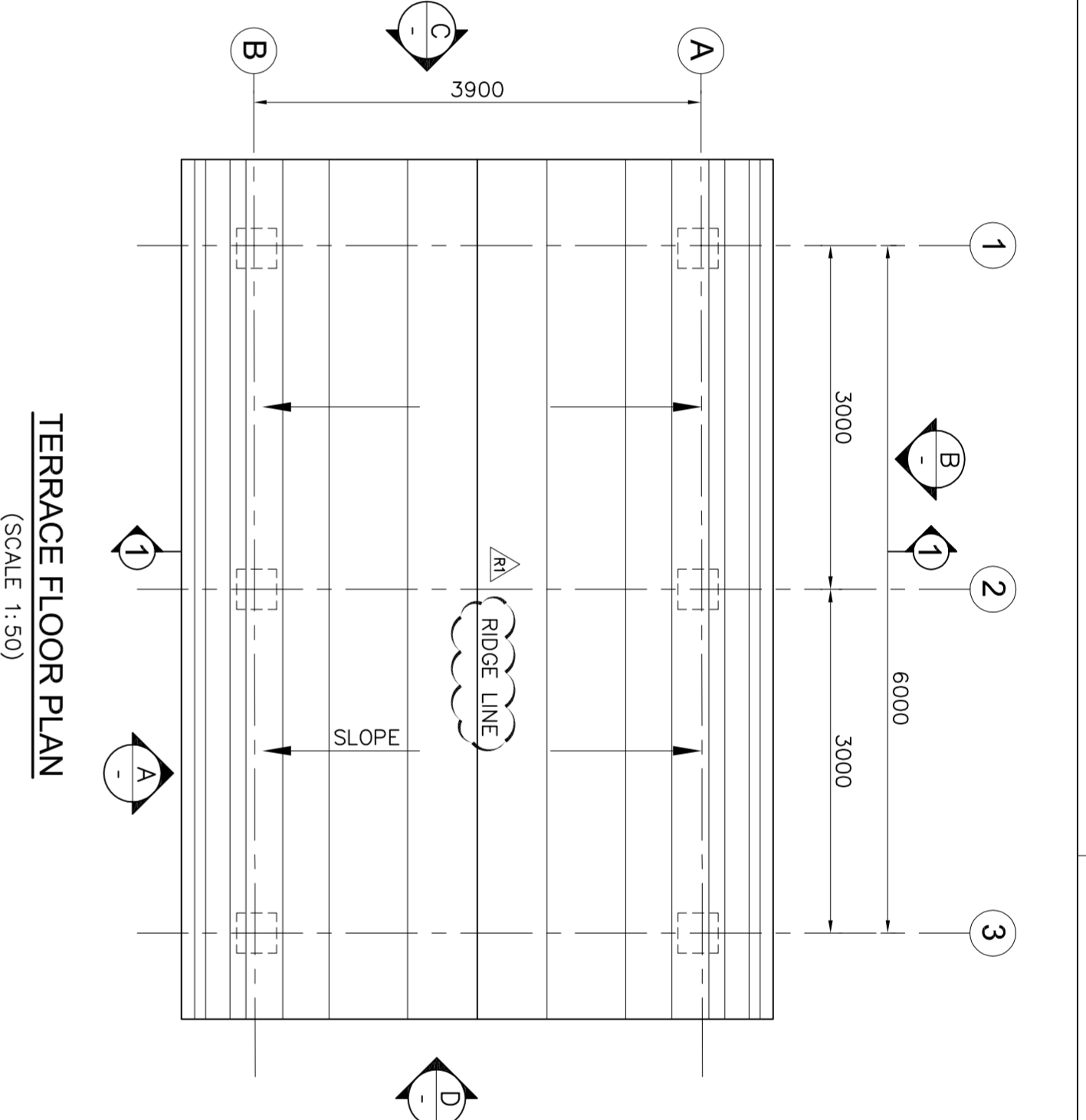
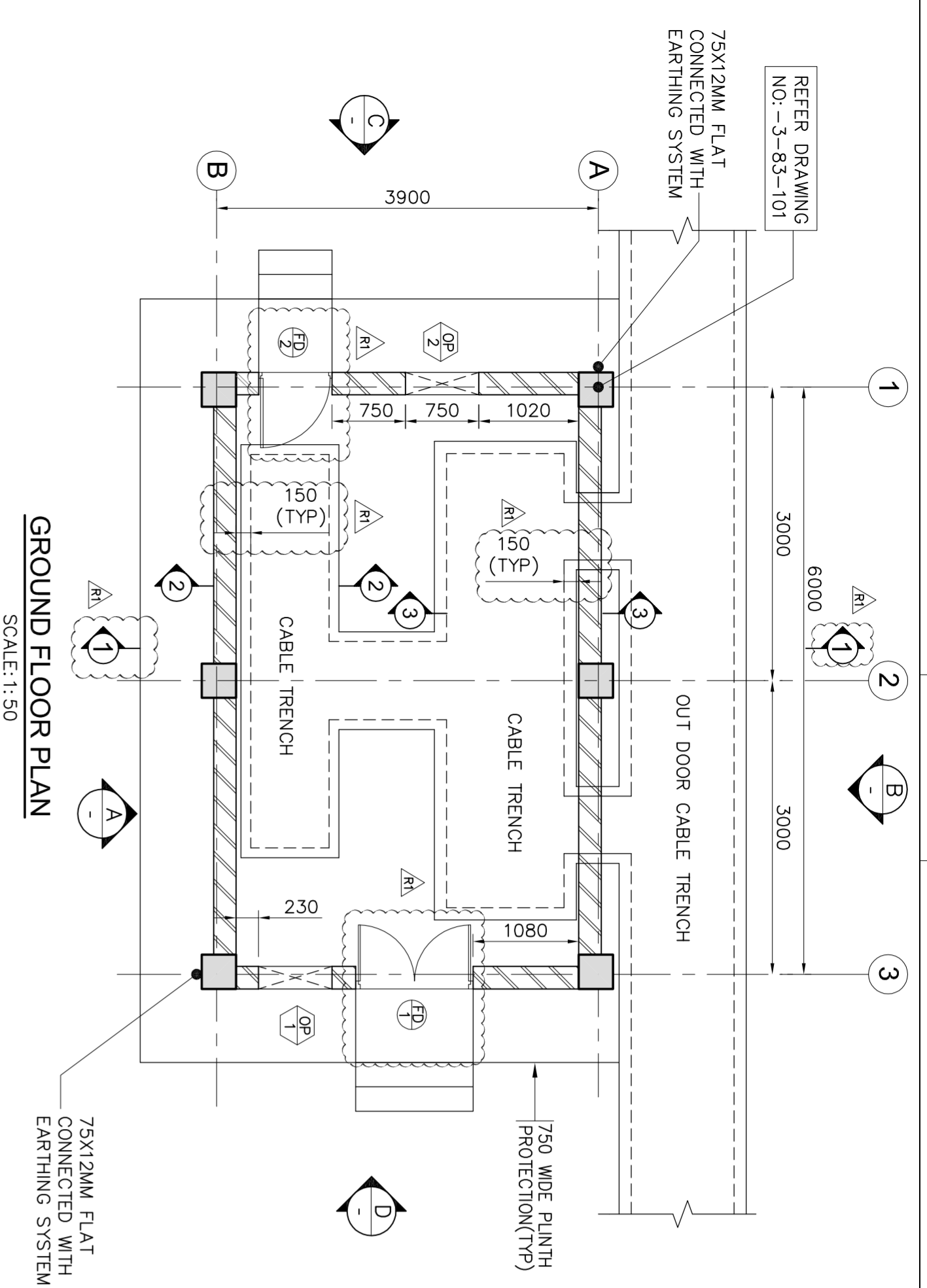

SCHEDULE OF JOINERY

SYMBOL	Nos	WIDTH	HEIGHT	REMARKS
FP	01	1200	2400	FIRE PROOF STEEL DOOR - DOUBLE SHUTTER
FP	01	750	2100	FIRE PROOF STEEL DOOR - SINGLE SHUTTER
OP	01	750	950	OPENING FOR FIXING AIR CONDITIONS
OP	01	750	950	OPENING FOR FIXING AIR CONDITIONS

FINISH SCHEDULE:

SERIAL NUMBER	ROOMS	FLOORS	INTERNAL WALLS	CEILING	EXTERNAL WALL
01	PANEL ROOM	POLISHED VITRIFIED TILES 600 X 600MM JOINT WITH WHITE CEMENT OVER CHICKEN WIRE MESH FIXED	CERMAMIC TILES OVER 12MM PLASTER WITH CHICKEN WIRE MESH ON ENTIRE SURFACE OF THE WALL	6MM THK PLASTER OVER CHICKEN WIRE MESH PAINTED WITH OIL BOUND DISTEMPER	18MM THK PLASTER IN TWO LAYER OVER CHICKEN WIRE MESH AND PAINTED WITH NOVALUX EXTERIOR PAINT

NOTE: FOR EARLIER REVISION REFER 3-83-102-DATED 05.06.12

RI	REVISION AS PER COMMENTS	21.08.12	ST
RO	ISSUED FOR APPROVAL	06.06.12	ST
Rev'd	Revision	Year/Week	Appt
		05.06.12	

- NOTES:**
1. ALL DIMENSIONS ARE IN MILLIMETER AND LEVELS ARE IN METERS, UNO.
 2. THIS DRAWING SHALL BE READ IN CONJUNCTION WITH CONTRACT TERMS AND CONDITIONS AND SPECIFICATION.
 3. OPENING ARE PROVIDED FOR INSTALLATION OF ACS IN CASE ONE AC IS PROVIDED, OTHER OPENING SHALL BE CLOSED.
 4. 22G X 12MM CHICKEN WIRE MESH TO BE PROVIDED FOR ALL WALL, FLOORING AND ROOF CHICKEN WIRE MESH SHALL BE CONNECTED WITH EARTHING SYSTEM THROUGH 75 X 12 MM FLAT FIXED ON DIAGONALLY OPPOSITE COLUMNS ON ITS OUTER SURFACE.
 5. OPENING SHALL BE SEALED PROPERLY (AFTER LAYING OF ALL CABLES) BY FIRE SEALING COMPOUND.

- LEGEND:**
- 230 THK BRICK WALL
 - FINISHED GROUND LEVEL
 - FINISHED FLOOR LEVEL
 - FINISHED PAVING LEVEL
 - TYPICAL THICKNESS

- REFERENCE DRAWINGS**
- (CONSTRUCTION)
- 3-00-004 - GENERAL NOTES FOR MASONRY STRUCTURES
 - 3-83-101 - LAYOUT OF RELAY BUILDING (ENGINEERING)
 - TB-0-343-316-115 - TRENCH LAYOUT HYDC - AGRA
 - 1.NL100409-604-R2 - OVER ALL LAYOUT - AGRA
 - C-ENGG-STD-PR-ARCH-3000 -R2- ARCHITECTURAL DRAWING OF PANEL ROOM
 - 3-00-010 - GENERAL NOTES - DOOR SCHEDULE
 - 3-00-011 - GENERAL NOTES - WINDOW SCHEDULE

FOR APPROVAL

POWER GRID CORPORATION OF INDIA LIMITED
(A Government of India Enterprise)

±800 kV 6000 MW HVDC Multi Terminal
NER/ER - NR/WR Interconnector-1

ABIP

AGRA CONVERTER STATION
RELAY BUILDING - (TYPE-2)
ARCHITECTURAL PLANS
SECTION AND ELEVATIONS

CONSULTANT

FIGHTNER Consulting Engineers (India) Private Limited

CHENNAI

AGRA

BHEL

BHARAT HEAVY ELECTRICALS LTD.
TRANSMISSION PRODUCTS DIVISION

5-771 80 LUDHYKA, SWEDEN
Telephone: +46 240 782100

AGRA