



**PRODUCT STANDARD
TURBINES & COMPRESSORS**

TC 58035

REV 01

PAGE 1 of 4

STOP VALVE

1.0) SCOPE :

This standard specifies the requirement of Stop Valve used for pressure gauges with lock and shank connection in bearing pedestal assembly of Steam turbine.

2.0) TECHNICAL REQUIREMENTS:

- a. Description : Stop Valve, without test connection & with vent screw
- b. Material
 - 1. Valve body : Stainless-Steel (X6CrNiMoTi 17 12 2 – DIN17440 or equivalent).
 - 2. Needle & seating : Corrosion and acid resistant stainless steel
 - 3. Packing : PTFE
 - 4. Hand Wheel : Heat-resistant plastic.
- c. Valve as per standard : DIN 16270
- d. Form : A
- e. Operating pressure : 250 kg/sq.cm (Max.: 400 kg/sq.cm)
- f. Temperature Range : -20^oC to +200^oC.

All technical delivery conditions shall be as per DIN 16270 except female end connection being NPT1/2” in place of G1/2”. All other details shall be as per the standard DIN 16270 and the figure shown below.

FORMAT
TD-203
REV-00

COPY RIGHT AND CONFIDENTIAL
The information on this document is the property of BHEL. It must not be used directly or indirectly in any way detrimental of company.

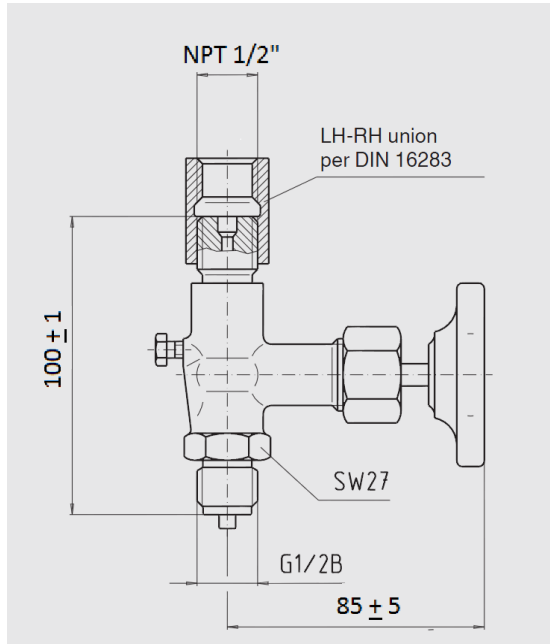

3.0) ACCEPTANCE TEST CERTIFICATE:

Test certificate shall be as per DIN 50049 / EN 10204 3.1

4.0) GUARANTEE CERTIFICATE:

A Guarantee certificate for 24 months of trouble free operation from the date of shipment or 12 months from the date of commissioning whichever is earlier shall be furnished.

5.0) DOCUMENTS:

Technical literature shall accompany the offer.

6.0) PACKING:

The material shall be properly packed to ensure that it is capable of withstanding transit risks without damage.



**PRODUCT STANDARD
TURBINES & COMPRESSORS**

TC 58035

REV 01

PAGE 3 of 4

7.0) MARKING:

7.1) A tag bearing the relevant 12 digit material code of BHEL shall be attached for each item.

7.2) The following details shall be marked on packing case:

1. Manufacturer's Name
2. BHEL Order No.
3. BHEL Standard No.

8.0) BHEL CODIFICATION: TC 9758035010 (for Variant 01)

FORMAT
TD-203
REV-00

COPY RIGHT AND CONFIDENTIAL
The information on this document is the property of BHEL. It must not be used directly or indirectly in any way detrimental of company.



**PRODUCT STANDARD
TURBINES & COMPRESSORS**

TC 58035

REV 01

PAGE 4 of 4

RECORDS OF REVISION

REV.	DATE	REV. DETAILS	REVISED	APPROVED
00	15-11-95	NEW	D.S.R	D.S.R
01	17-05-13	Technical requirements (Clause 2.0) revised.	Santosh.	Ashok.

FORMAT
TD-203
REV-00

COPY RIGHT AND CONFIDENTIAL
The information on this document is the property of BHEL. It must not be used directly or indirectly in any way detrimental of company.