



भारत हेवी इलेक्ट्रिकल्स लिमिटेड

(भारत सरकार का उपक्रम)

BHARAT HEAVY ELECTRICALS LIMITED

(A Govt. of India Undertaking)

TCN – 10

Ref: PSER:SCT:NKP-M1632:TCN-10

Date: 27-02-2015

Sub	Tender change notice (TCN) 10	
Job	Design, engineering, manufacturing, supply/ delivery, erection, commissioning, trail run, handing over to customer, etc of Compressed Air System for NTPC, 3x660 MW, North Karanpura Super Thermal Power Project, Jharkhand.	
Ref	1.0	Tender No. PSER:SCT:NKP-M1632:14
	2.0	BHEL's NIT, vide reference no PSER:SCT:NKP-M1632:14:4102 , Dated 04-12-2014.
	3.0	BHEL's TCN-01, vide reference no PSER:SCT:NKP-M1632:TCN-01, dated 20-12-2014.
	4.0	BHEL's TCN-02, vide reference no PSER:SCT:NKP-M1632:TCN-02, dated 23-12-2014.
	5.0	BHEL's TCN-03, vide reference no PSER:SCT:NKP-M1632:TCN-03, dated 03-01-2015.
	6.0	BHEL's TCN-04, vide reference no PSER:SCT:NKP-M1632:TCN-04, dated 09-01-2015.
	7.0	BHEL's TCN-05, vide reference no PSER:SCT:NKP-M1632:TCN-05, dated 14-01-2015.
	8.0	BHEL's TCN-06, vide reference no PSER:SCT:NKP-M1632:TCN-06, dated 27-01-2015.
	9.0	BHEL's TCN-07, vide reference no PSER:SCT:NKP-M1632:TCN-07, dated 28-01-2015.
	10.0	BHEL's TCN-08, vide reference no PSER:SCT:NKP-M1632:TCN-08, dated 07-02-2015.
	11.0	BHEL's TCN-09, vide reference no PSER:SCT:NKP-M1632:TCN-09, dated 16-02-2015.
	12.0	All other pertinent issues till date.

With reference to above, following points/ documents, relevant to tender, may please be noted and complied with while submitting offer.

- 1.0 B35 mounting drawing for 710kW/3.3kV/4pole motor is furnished vide this TCN and the dimensional details for 630kW/3.3 kV/4 pole motor was furnished in our earlier TCN of this Tender. Although drawing is for 500kW, outer dimensions will remain same for 630kW motor as well.
- 2.0 Outline General Arrgt. Drawing-1LA4450-4 to Volume-II, is attached herewith.
- 3.0 The Due Date of tender submission is extended from 27-02-2015 to 09-03-2015 (15=00 Hours).
- 4.0 Revised 'No deviation certificate' as per enclosed Annexure-2. Bidder shall submit no deviation certificate as per enclosed format only.
- 5.0 All other terms & conditions shall remain unchanged.

Thanking you,

Yours faithfully,
for BHARAT HEAVY ELECTRICALS LTD

ENGR (SCT)

Encl

1.0 As above.

पावर सेक्टर पूर्वी क्षेत्र (मुख्यालय)

POWER SECTOR EASTERN REGION, DJ-9/1, SECTOR-II, SALT LAKE CITY, KOLKATA - 700 091

फैक्स/Fax : (033) 23211960

फोन/Phone : बोर्ड/EPABX : 23211691, 23211798, 23211796

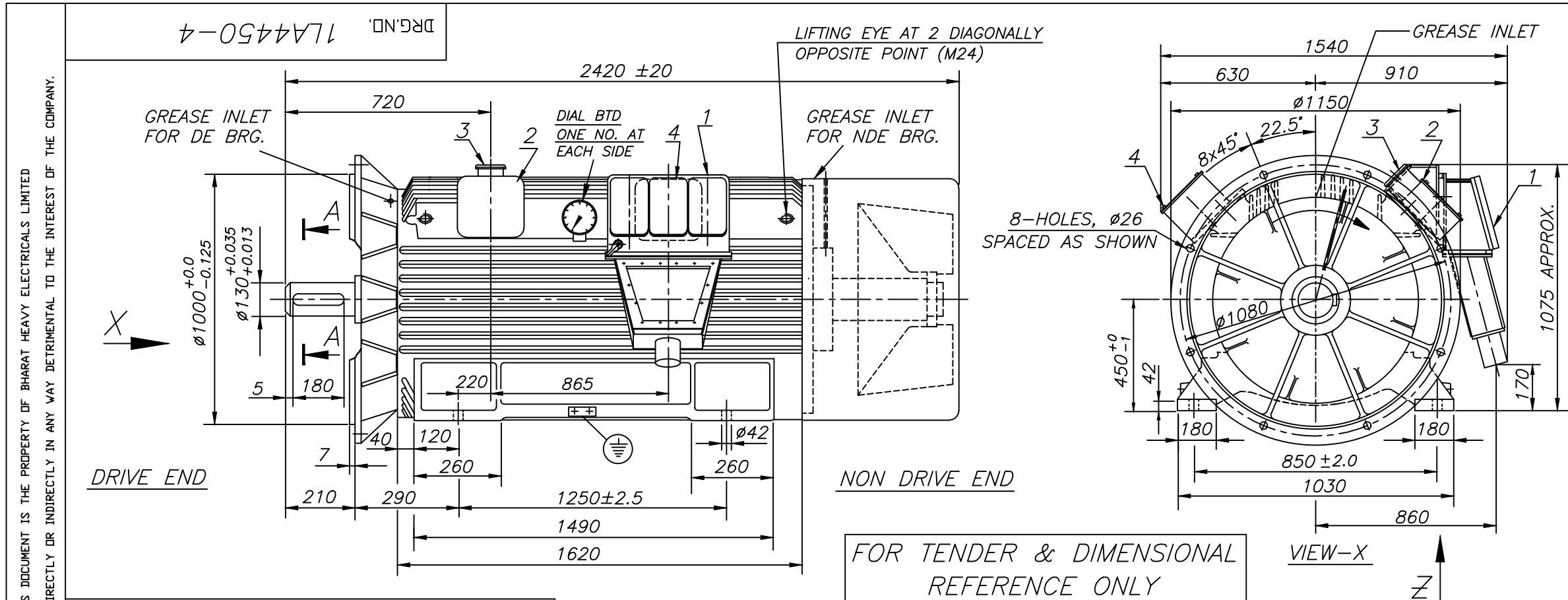

MOTOR FITMENTS

- (I) TERMINAL BOXES FOR :
 - 1 - STATOR (PSTB TYPE)
 - 2 - ETD'S+BTD'S
 - 3 - SPACE HEATERS
 - 4 - NEUTRAL POINT

- (II) TEMPERATURE SENSORS
 - (A) WDG. ETD'S 12 Nos. 3-WIRES PT.TYPE, 100 Ω AT 0°C (SIMPLEX)
 - (B) BEARING RTD'S 2 Nos. 4-WIRES PT.TYPE, 100Ω AT 0°C (DUPLEX)
 - (C) 2-NOS. DIAL TYPE BTD. (1 EACH AT DE & NDE BRGS)

- (III) OTHERS
 - SPACE HEATERS 2 NOS. TOTAL POWER 315 WATTS (630 WATTS EACH) 240 VOLTS, 50 Hz

- (IV) FANS : BI-DIRECTIONAL
- (V) HOLDING DOWN BOLTS:- 4xM36x120 LONG

- (VI) CABLE DETAILS:-
 - STATOR:-1Rx3Cx240 SQ.MM MAX., XLPE CABLE
 - SPACE HEATER:- 1Rx3Cx2.5 SQ.MM, A2XFY.

TECHNICAL DATA

RATING	710	kW
SPEED	1500 (SYN)	rpm
VOLTAGE 3 PHASE 50 Hz	3300	VOLTS
FULL LOAD AMP STATOR	-	AMP
APPROX. WEIGHT OF MOTOR	5000	kg
APPROX. WEIGHT OF ROTOR	1650	kg
GD ² OF ROTOR	88	kgm ²
MAX. FOUNDATION LOADING (ALTERNATING) PER MOTOR LONGITUDINAL SIDE	51	kN UPWARDS
	101	kN DNWARDS
BEARINGS	DE	NU230M+6230C3
	NDE	NU1028M

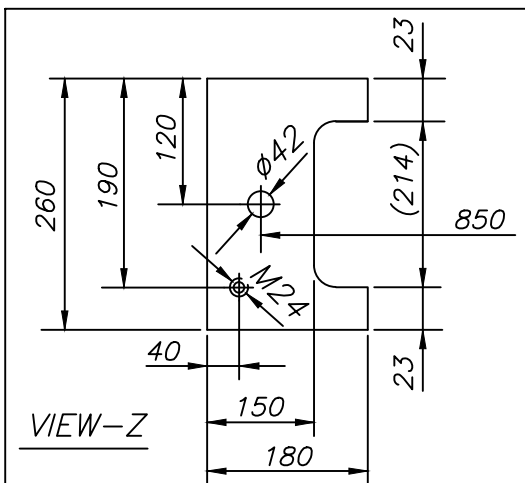
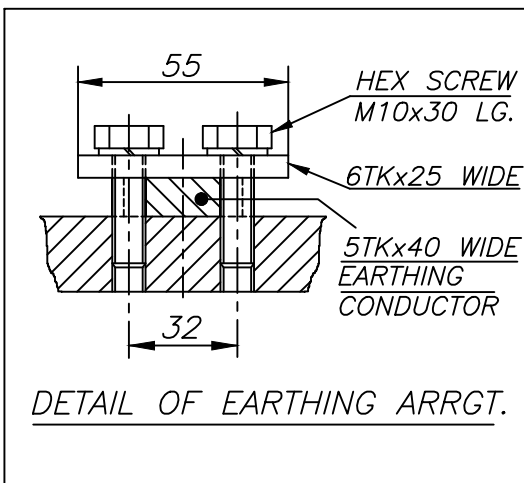
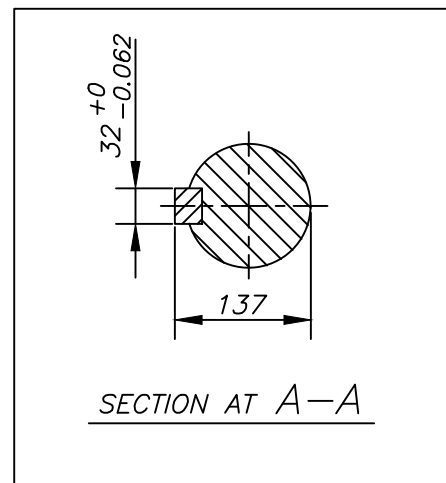

TENDER/1LA4450-4 FOOT-CUM-FLANGE REF. DRG. NO.

SIGN & DATE

INVENTORY NO.

LUBRICATION: GREASE	SERVOGEM-3 OF IOC OR EQUIVALENT
DIRECTION OF ROTATION VIEWED FROM DRIVE END	BI-DIRECTIONAL (CLOCKWISE)
PAINT SHADE SPECIFICATION	SHADE NO. 631 OF IS-5 EPOXY PAINT-LIGHT GREY.
TYPE OF ENCLOSURE	TEFC

ADDITIONAL INFORMATION	TYPE OF PRODUCT : SQ. CAGE INDUCTION MOTOR	DRIVE : COMPRESSOR
ENQUIRY: PSER:SCT:NKP:M1632:14	NAME OF CUSTOMER : BHEL PEM	
	NAME OF PROJECT : 3X660 MW, NORTH KARANPURA, JHARKHAND	

DISTRIBUTION OF PRINTS AME-1	BHARAT HEAVY ELECTRICALS LTD. BHPAL	DRN	NAME	SIGN.	DATE	NO. OF VAR.
		CHD.	P.K.DIVYA		25.02.15	
		APPD	A.K.M		25.02.15	

REV.	DATE	ALTERED.	REV.	DATE	ALTERED.	REV.	DATE	ALTERED.	DEPT.	GRADE OF UN. TOL.	SCALE	WEIGHT(Kg.)	REF. TO ASSY. DRG.	ITEM NO.	NO. OF ITEMS
		CHECKED.			CHECKED.			CHECKED.	AME		NTS				
		APPROVED.			APPROVED.			APPROVED.	404	DIM. C/M/F					

FOR TENDER PURPOSE ONLY PSER:SCT:NKP-M1632:14 TCN-10	TITLE	1	3	7	22	23	24
	OUTLINE GENERAL ARRGT. 1LA4450-4, TEFC, IP55, B35	CARD CODE		DRAWING NO. 1LA4450-4			REV 00
			SHEET NO. 01	NO. OF SHEETS	01		

FORMAT FOR NO DEVIATION CERTIFICATE
(To be submitted in the bidder's letter head)

BHARAT HEAVY ELECTRICALS LIMITED,
Power Sector - Eastern Region,
Plot no 9/1, DJ Block, Sector – II, Salt Lake City,
Kolkata – 700 091

Sub	No Deviation Certificate.	
Job	Design, engineering, manufacturing, supply/ delivery, erection, commissioning, trial run, handing over to customer, etc of Compressed Air System for NTPC, 3x660 MW, North Karanpura Super Thermal Power Project, Jharkhand.	
.Ref	01	Tender No. PSER:SCT:NKP-M1632:14
	02	BHEL's NIT, vide reference no PSER:SCT:NKP-M1632:14:4102 , Dated 04-12-2014.
	03	BHEL's TCN-01, vide reference no PSER:SCT:NKP-M1632:TCN-01, dated 20-12-2014.
	04	BHEL's TCN-02, vide reference no PSER:SCT:NKP-M1632:TCN-02, dated 23-12-2014.
	05	BHEL's TCN-03, vide reference no PSER:SCT:NKP-M1632:TCN-03, dated 03-01-2015.
	06	BHEL's TCN-04, vide reference no PSER:SCT:NKP-M1632:TCN-04, dated 09-01-2015.
	07	BHEL's TCN-05, vide reference no PSER:SCT:NKP-M1632:TCN-05, dated 14-01-2015.
	08	BHEL's TCN-06, vide reference no PSER:SCT:NKP-M1632:TCN-06, dated 27-01-2015.
	09	BHEL's TCN-07, vide reference no PSER:SCT:NKP-M1632:TCN-07, dated 28-01-2015.
	10	BHEL's TCN-08, vide reference no PSER:SCT:NKP-M1632:TCN-08, dated 07-02-2015.
	11	BHEL's TCN-09, vide reference no PSER:SCT:NKP-M1632:TCN-09, dated 16-02-2015.
	12	BHEL's TCN-10, vide reference no PSER:SCT:NKP-M1632:TCN-10, dated 27-02-2015.
	13	All other pertinent issues till date.

Dear Sirs,

With reference to above, this is to confirm that as per tender conditions, we have visited site before submission of our offer and noted the job content & site conditions etc. We also confirm that we have not changed/ modified the tender documents as appeared in the website/ issued by you and in case of such observance at any stage, it shall be treated as null and void.

We hereby confirm that we have not taken any deviation from tender clauses together with other references as enumerated in the above referred NIT. We hereby confirm our unqualified acceptance to all terms & conditions, unqualified compliance to technical specification, integrity pact (if applicable) and acceptance to reverse auctioning process.

In the event of observance of any deviation in any part of our offer at a later date whether implicit or explicit, the deviations shall stand null & void.

We confirm to have submitted offer in accordance with tender instructions and as per aforesaid references.

Thanking you,

Yours faithfully,

(Signature, date & seal of authorized representative of the bidder)

<p>पावर सेक्टर पूर्वी क्षेत्र (मुख्यालय) POWER SECTOR EASTERN REGION DJ-9/1, SECTOR-II, SALTLAKE CITY, KOLKATA - 700 091 फैक्स/Fax : (033) 23211960 फोन/Phone : बोर्ड/EPABX : 23211691, 23211798, 23211796</p>
--