



ISO 9001-2000, ISO 14001 and
OHSAS 18001 certified company

Sub-Contract and Purchase
Deptt.

Bharat Heavy Electricals Limited

(A Govt. of India Undertaking)

Power Sector – Northern Region,

Plot No. 25, Sector - 16A, Distt. Gautam Budh Nagar

NOIDA – 2 01301 (INDIA)

Phone: 91-120-2416500/2416262 Fax 91-120-2416528

Email: cs@bhelnsr.co.in /susmitabasu@bhelnsr.co.in

TENDER ENQUIRY NO: BHEL/PSNR/SCP/CS/E- 2538

DATE: 27.01.2014

TENDER ENQUIRY

BHEL Power Sector, Northern Region invites sealed quotation from **Original Equipment Manufacturer (OEM) OR their Authorized dealer in two part bid system** for the following item as follow:

Enquiry No.	DESCRIPTION	LAST DATE OF TENDER SUBMISSION & OPENING	DELIVERY SCHEDULE
BHEL/PSNR/SCP/CS/ E-2538	SUPPLY, INSTALLATION & COMMISSIONING OF LOCK BOLT MACHINE (INCLUDING SPARE PARTS AS PER CLAUSE 7.0 OF ANNEXURE - 1). QUANTITY – 1 NO.	18.02.2014 AT 1530 HRS.	Within EIGHT (8) WEEKS from the date of P.O.

DESTINATION FOR SUPPLY IS AS FOLLOWS:

SDO STORE (S&T), O&M, GHTP, LM BATHINDA, DIST. BHATINDA – 151111, PUNJAB.

QUALIFYING REQUIREMENTS / PAST EXPERIENCE:-

- a) BIDDER SHOULD BE **ORIGINAL EQUIPMENT MANUFACTURER (OEM)** OF THE QUOTED EQUIPMENT.

“OR”

- b) BIDDER SHOULD BE **AUTHORISED DEALER FROM ORIGINAL EQUIPMENT MANUFACTURER (OEM)** OF THE QUOTED EQUIPMENT.

NOTE:

FOR Sl. No. 1 (a) BIDDER TO SUBMIT COMPANY REGISTRATION CERTIFICATE AS A MANUFACTURER AND LEAFLET/ CATALOGUE OF QUOTED ITEM.

FOR Sl. No. 1 (b) BIDDER TO SUBMIT AUTHORISATION CERTIFICATE FROM OEM ALONG WITH LEFLET/CATALOGUE OF THE QUOTED ITEM.

2. BIDDER TO SUBMIT COPY OF ATLEAST ONE P.O. FOR THE SUPPLY OF LOCK BOLT MACHINE IN LAST 3 YEARS FROM THE DATE OF BID SUBMISSION.

NOTES:-

The Tender Document comprise of following;

- ANNEXURE- 1 (TECHNICAL SPECIFICATIONS)
- ANNEXURE-2 (IMPORTATNT NOTES)
- ANNEXURE-3 (SPECIAL TERMS & CONDITIONS)
- ANNEXURE-4 (GENERAL TERMS & CONDITIONS)
- ANNEXURE-5 (UNPRICE FORMAT)
- ANNEXURE – 6 (PRICE SCHEDULE)
- ANNEXURE – 7 (CERTIFICATE FOR NO DEVIATION)
- ANNEXURE – 8 (REVERSE AUCTION FORMAT AND TERMS & CONDITIONS)
- ANNEXURE – 9 (PBG FORMAT)

SR.ENGINEER/PURCHASE

TECHNICAL SPECIFICATIONS OF LOCK BOLTING MACHINE

1.0 Scope: Design, manufacturing, Inspection, Testing, Supply and commissioning of the Lock Bolt Machines complete with Hydraulic Power pack, including guns and Hydraulic Hose sets along with all necessary accessories, commissioning spares for fastening the Lock bolts with shock bar and collecting electrodes in Electrostatic Precipitators.

2.0 Application: The offered Lock Bolt machines are to be used for fixing the lock bolts supplied in line with the Lock bolts drawing attached for ½ inch(12mm) and 5/8 inch(16mm) sizes through swaging process in Electrostatic Precipitators.

3.0 Reference: Lock Bolts drawing: a) 16mm--3-79-024-01566 Rev 01 & b) 12mm--3-79-024-01567 Rev 01 and c) Annexure showing the details of components required to be fastened through swaging process using the offered Lock bolt Machine.

4.0 Standards Applicable: The lock Bolt machine-Accessories and Materials should confirm to best quality and specifications to relevant DIN/ISO/ANSI standard or any other equivalent international standards.

5.0 Design Requirement: The offered Lock Bolt machines should include the following:

a) Hydraulic Power Pack to develop required pressure on Installation Tool—One number per unit.

b) Suitable installation Tool for fixing 12mm & 16mm Lock Bolts-one set per unit.

c) Suitable Nose assembly for 12mm and 16mm per unit.

d) Hydraulic Hose one set (For Pull and Return) 15 meter length per unit.

e) Other components required for successful fastening of the lock bolts and ensuring perfect swaging process to meet the Tensile and shear values indicated in the drawing, not indicated in the specification, and also should be part of supply by the vendor.

f) The offered Lock Bolting Machines should be of proven and robust design and suitable for operations in Indian climatic conditions such as saline atmospheres, ambient temperatures up to 50 deg. C.

g) Installation Tool should be Robust and rugged design, to last a long working life in extreme conditions.

h) Range of hydraulic power units to deliver the extreme high pull pressure required for secure, long lasting assembly at high speed with adequate Tank capacity and necessary pressure relief valves etc. ensuring the safety of the operator as well as safe environment.

i) Electrical Motor shall be of suitable capacity, 3 Phase, 440V, 50Hz along with starter, complete with necessary electrical components for safe and successful performance of the offered Lock Bolt Machine.

j) Choice of placing heads and nose equipment to suit the lock bolts indicated in the reference drawing 12mm and 16mm supplied by many vendors.

k) Easy-to-change nose equipment and range of hydraulic hoses in different lengths enable the tool to be adapted to suit local assembly requirements.

l) The Powering should be light weight portable hydraulic power installation Tool. Construction should be strong tubular frame makes for easy manual handling and provides protection for main components when used in rugged conditions.

m) Power rig should also features a built in pressure gauge and large oil filter for the hydraulic system. The Powering automatically starts when the installation Tool trigger is activated and stops when the installation Tool cycle is complete.

n) All lubricants, consumables for successful commissioning of the offered lock bolt machines should be supplied by the vendor without any extra cost.

6.0 Quantity required: One set of complete Lock Bolt machine with accessories and spares indicated above.

7.0 List of Spares required along with offered Lock Bolt Machines:

Sl. No	Description	Quantity
01	12mm Nose assembly	01
02	16mm Nose assembly	01
03	Installation Tool(Gun) suitable for 12mm and 16mm	01
04	Trigger switch	01
05	Male Plug	01
06	Anvil (for 12mm and 16mm)	01
07	Follower (for 12mm and 16mm)	01
08	Ejector (for 12mm and 16mm)	01
09	Release (for 12mm and 16mm)	01
10	Collet (for 12mm and 16mm)	01
11	"O " Ring set (for 12mm and 16mm)	01
12	Jaw set (for 12mm and 16mm)	01
13	Back up ring set for 12mm	01
14	Retainer for 12mm	01
15	Hydraulic Quick release coupling assembly for 12mm	01
Any other items required for trouble free operation of the offered Lock bolting Machine, not indicated above should also, be spelt in the offer for evaluation.		

8.0 Inspection: The offered Lock bolt machines will be inspected, Tested for performance at site. The vendor should furnish the Load test carried out at works for BHEL scrutiny. Non-performance of the Lock bolt machines during inspection, Testing and commissioning, will be rejected.

9.0 Installation & Commissioning: Installation and commissioning will be at site under the supervision of competent Engineer from the vendor. Lock Bolt Machines will be tested at site in the presence of BHEL's Engineers as part of Load Test and Acceptance Test and Lock Bolt Machine will be taken over after successful completion of such tests,

10.0 Documents to be submitted along with offer without which offers will not be evaluated:

- a) Confirmation for the performance of the offered Lock bolt Machine for the lock bolts sizes indicated in the respective drawings.
- b) Catalogues, Drawings, Technical data, performance charts for the offered Lock Bolt machine.
- c) Quality Plan for the offered Lock Bolt Machine which should include major components viz Power Pack, Nose assembly, Hydraulic Hoses.
- d) Confirmation on adequacy of the list of spares indicated in the specification.
- e) List of items required for performance of the Lock Bolt machines trouble free for minimum 2 years and not listed in the specification.
- f) Reference list for the supply of similar Lock bolt machine earlier.
- g) Load Test chart carried out for similar sizes earlier.

11.0 Documents to be submitted after P.O by the successful vendor before despatch:

- a) Load Test certificate of the Lock Bolting Machines carried out at vendor works.
- b) Warranty certificates for the goods.
- c) Five sets of Catalogue of the Lock Bolting Machine supplied, O&M Manuals including all Data for the items needs to be attended/replaced Viz Hydraulic Oil, specification, quantity required, Lubrication Chart if any, during the regular maintenance, Part Lists of the supplied Lock Bolting Machine, Manuals for the bought out items are to be part of dispatch along with the Lock bolting machine.
- d) Gross and Net weight of the Lock Bolting Machines along with accessories in Kgs.
- e) Volume of the offered Lock Bolting Machine including the number of packages and respective weights & Volume along with shipping List.

12.0 Deviation: Deviation if any, from technical specification should be clearly specified with relevant technical details for evaluation.

13.0 Guarantee: The offered lock bolts should be guaranteed by the vendor for any manufacturing defect, improper material used, Poor workmanship or non-performance of the Lock bolt machine and accessories for the period of 12 months from the date of commissioning at site or 8000 hrs of operation whichever is earlier. Any materials found defective or fails within the Guarantee period due to any of the above reason within the above period will have to be replaced by the vendor free of cost and any charges including To & Fro, transportation charges should be borne by the vendor.

14.0 Warranty: The offered Lock Bolting Machine should carry a Warranty for a period of 12 months from the date of installation and commissioning at Site. Rectification / Replacement required during the warranty period should be arranged by the vendor free of cost including To & Fro transport charges and other expenditures, Taxes etc payable on replacement items.

15.0 Packing and Despatch: All the components should be packed ensuring no damage during handling, loading, Unloading, Transit and storage. Each Package should be identified with necessary Tags and instructions for handling and storage.

99910-720-67-3
DRAWING NO.

ALL DIMENSIONS ARE IN MILLIMETRES

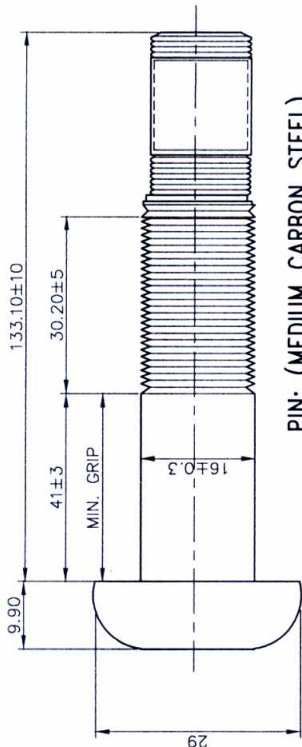

PIN: (MEDIUM CARBON STEEL)
ROD ϕ 32-150

SHOCK BAR WITH SHOCK PAD ASSY

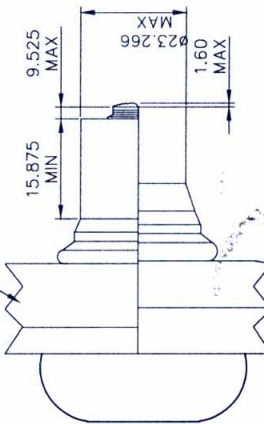

INSTALLED FASTENER

FASTENER VALUES	
MINIMUM CLAMP	19,200 LBS
MINIMUM TENSILE	27,100 LBS
MINIMUM SHEAR	22,500 LBS

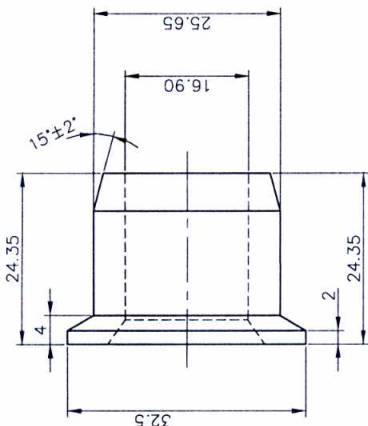

COLLAR: LOW CARBON STEEL



Note:

Manufacturer's identification shall be marked by unique identifier to identify the manufacturer. Located on the top of the bolt head and shall be raised or depressed at the manufacturer's option.

THE OFFERED LOCK BOLTS SHALL BE AS PER
BS 7805:PART 2:1997 OR EQUIVALENT

ROD ϕ 32-30

TYPE OF PRODUCT
OR NAME OF
CUSTOMER/PROJECT

CAUTION: The information on this document is the property of BHARAT HEAVY ELECTRICALS LTD. It must not be used directly or indirectly in any way detrimental to the interest of the company.

BHEL
BHARAT HEAVY ELECTRICALS LTD.
UNIT: BOILER AUXILIARIES PLANT,
RANIPET - 632 406.

DEPT. AACS
CODE 862
GRADE OF UNIT/DIM PR:QA-500
SCALE N.T.S.
WEIGHT (KG) N.T.S.

DRN CHD M.MANI
NAME MANICK M.MANI
SIGN M. Mani
DATE 01-06-09
NO OF VAR -

REV	DATE	ALTERED	So:jal
01	23/01/12	CHECKED	C.Ganesh
ZONE Note added.			

APPD M.MANI
REF. TO ASSY/OLD DRG.
4-79-024-00777

NO. OF ITEMS
ITEM NO.

TITLE
SHOCK PAD LOCK BOLT (5/8")
M16X65 & COLLAR

CARD CODE U 01
DRAWING NO. 3-79-024-01566
REV 01

DRAWING NO
3-79-024-01567

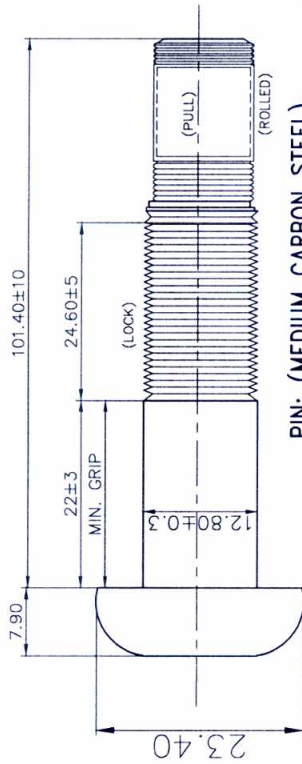

PIN: (MEDIUM CARBON STEEL)
ROD Ø25-130

SHOCK BAR ASSY WITH COLLECTING ELECTRODE

INSTALLED FASTENER

FASTENER VALUES	
MINIMUM CLAMP	12,050 LBS
MINIMUM TENSILE	17,050 LBS
MINIMUM SHEAR	14,400 LBS

ALL DIMENSIONS ARE IN MILLIMETRES

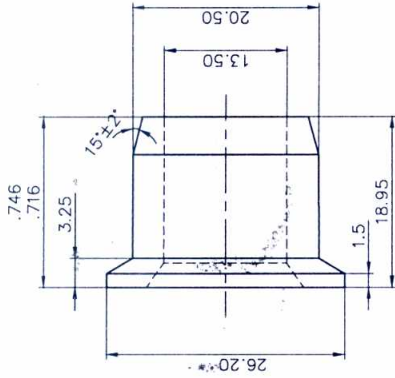

COLLAR: LOW CARBON STEEL
ROD Ø32-30

Note:

Manufacturer's identification shall be marked by unique identifier to identify the manufacturer. Located on the top of the bolt head and shall be raised or depressed at the manufacturer's option.

THE OFFERED LOCK BOLTS SHALL BE AS PER
BS 7805:PART 2:1997 OR EQUIVALENT

TYPE OF PRODUCT
OR NAME OF
CUSTOMER/PROJECT



BHARAT HEAVY ELECTRICALS LTD.,
UNIT: BOILER AUXILIARIES PLANT.
RANIPET - 632 406.

DRN
M.MANI

CHD
M.MANI

APPD
M.MANI

NAME
M.MANI

SIGN
M.MANI

DATE
01-06-09

NO. OF VAR.
01-06-09

NO. OF ITMS
01-06-09

DEPT
A003

GRADE OF UNTOOL DIM
PR-0A-500

SCALE
N:1S

WEIGHT (KG)
N/A

REF. TO ASSY/OLD DRG.
4-79-024-00776

CARD CODE
U 01

DRAWING NO.
3-79-024-01567

REV
01

REV	DATE	ALTERED	Signed
01	23/01/12	CHECKED	C.Ganesh
		ZONE	Note added.

CAUTION: The information on this document is the property of BHARAT HEAVY ELECTRICALS LTD. It must not be used directly or indirectly in any way detrimental to the interest of the company.

Size A3

Annexure to the Technical specification for Lock Bolt Machine

TEP:PE:CG:Lock BoltMachines:Rev:01

Typical lock bolt arrangement--both sizes M12x45 and M16x65

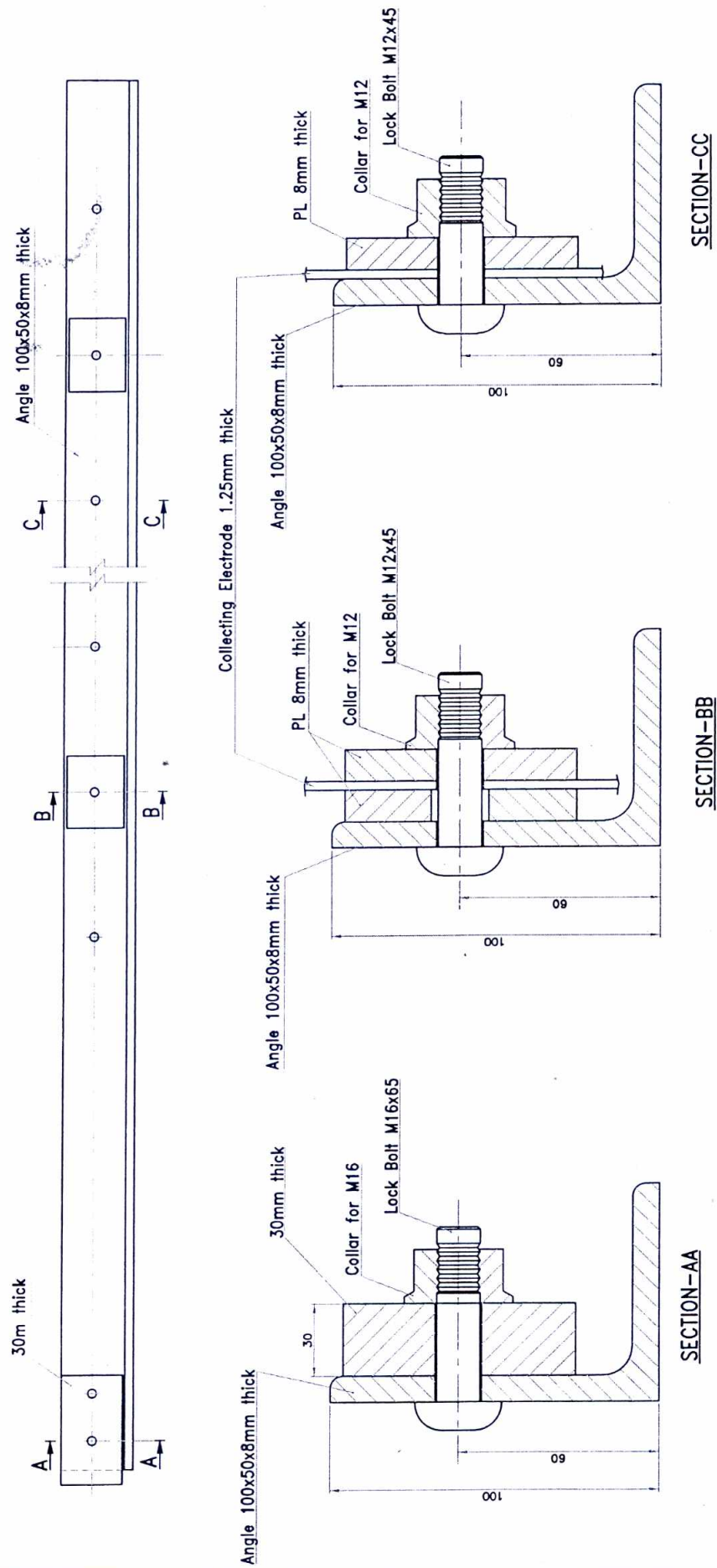

M16 x 65 Lock Bolt and collar fastening

M12 x 45 Lock Bolt and collar fastening

Prepared: Sangeetha

Checked:A.Parasuraman

Approved:C.Ganesh

IMPORTATNT NOTES

1. Bidders not offering the material as per specification described in Annexure – 1 are liable to be rejected.
2. All corrigenda, addenda, amendments and clarifications to this Tender **will be hosted in the web page and not in the newspaper**. Bidders shall keep themselves updated with all such amendments.
3. BHEL reserves the right to split, accepts or rejects any or all tenders without assigning any reason what so ever.
4. BHEL takes no responsibility for any delay/loss of documents or correspondences sent by courier/post.
5. Sealed tenders in two part bid system i.e. Part-I – Techno-Commercial bid and Part-II - Price bid are invited for supply, of "**LOCK BOLT MACHINE.**" as per detailed specifications in Annexure-1, so as to reach us before the date of opening. The tenders (Part I only) will be opened at **15.30 PM (IST) on 18.02.2014.**

Note: In case the due date of opening of tender becomes a non-working day, then the due date & time of offer submission and opening of tenders get extended to the next working day.

6. Tender should not be addressed to any Individual's name but only by designation to:

**SR. ENGINEER/ PURCHASE
BHARAT HEAVY ELECTRICALS LIMITED
POWER SECTOR-NORTHERN REGION,
HRDI & ESI Complex, Plot no.25, Sector 16 A,
NOIDA –201301 (INDIA)**

7. TENDERS TO BE SUBMITTED IN TWO PARTS:

Part: I: Techno-commercial bid containing technical details along with commercial offer containing the following;

- (i) Covering letter/Offer forwarding letter of Tenderer.
- (ii) Supporting documents against Qualifying Requirements (QR) and vendor confirmation regarding technical specification.
- (iii) Duly filled-in 'No Deviation Certificate' as per Annexure -7.

Note:

- a. In case of any deviation, the same should be submitted separately for technical & commercial parts, indicating respective clauses of tender against which deviation is taken by bidder. It shall be specifically noted that deviation recorded elsewhere shall not be entertained.
 - b. BHEL reserves the right to accept/reject the deviations without assigning any reasons, and BHEL decision is final and binding. In case of unacceptable deviations, BHEL reserves the right to reject the tender.
- (iv) **Acceptance to commercial terms and conditions by submitting duly signed and stamped all pages of Tender document as a proof of acceptance.**
 - (v) All Amendments/Correspondences/Corrigenda/Clarifications/Changes/ Errata etc. pertinent to this tender.
 - (vi) Bidders shall submit their offer in INR only, the same to be indicated in their offer (Part-I).
 - (vii) Commercial: This part shall include / indicate the following:
 - (a) **Station of dispatch**
 - (b) **Taxes & duties applicable.**
 - (c) **Delivery Schedule**

- (viii) Copy of "Un-Priced Format as per Annexure - 5" i.e., without the price details to be enclosed with clearly mentioning that whether **QUOTED or NOT APPLICABLE**. (No hidden charges shall be accepted).
- (ix) Any other details preferred by bidder with proper indexing.

PART: II: PRICE BID AS PER ANNEXURE – 6, DULY FILLED, SIGNED AND STAMPED. IT SHOULD INCLUDE FOLLOWING:

- (i) Offered price (as per Rate Schedule format enclosed).
- (ii) The bidders should fully understand scope of supply and their responsibilities under the tender specifications before quoting. The bidders are required to quote only in Indian Currency for the rates as per rate schedule, in part-II price bid. Conditional price bid or price bid with any deviation are liable to be rejected. No cutting / erasing /overwriting shall be done in the price bid.

Note: Bidder may ensure to sign each page of the tender document / their offer while submitting techno - commercial offer/ price-bid.

8. Following should be super scribed on the envelopes of the two parts of the Bid.

Part I: Techno-Commercial Bid:-

Tender for: _____

Tender No. _____ Due on: _____

Part II: PRICE BID:

Tender for: _____

Tender No. _____

9. BOTH PART-I & PART-II SHOULD BE INDIVIDUALLY SEALED & SUPERSCRIBED AS INDICATED ABOVE & SHALL BE ENCLOSED IN ONE MAIN ENVELOPE DULY SEALED & SUPERSRIBED AS:

Tender for: _____

Tender No. _____ **Due on:** _____

Containing Part I and Part II of the offer

The tenders should be sent sufficiently in advance so as to reach before the due date and time. BHEL shall not be responsible in case of delay in receipt of tenders.

10. LANGUAGE & CORRECTIONS

- a) The Tenderer shall quote the rates in Hindi/English language and international numerals only. The rates shall be entered in figures as well as in words. For the purpose of tender, the metric system of units shall be used.
- b) All entries in the tender shall either be typed or written legibly in ink. Erasure and over-writings are not permitted and may render such tenders liable for rejection.
- c) Tenderer's offer, remarks and deviations, shall be with reference to sections and clause numbers given in the tender documents.
- d) All cancellations and insertions shall be duly attested by the tenderer.
- e) All columns for price format shall be filled. If not applicable, please write "NA"

11. TENDER EVALUATION

The Purchaser will examine the bids to determine whether they are complete, whether any computational errors have been made, whether required sureties have been furnished, whether the documents have been properly signed and whether the bids are generally in order.

12. PRICE DISCREPANCY

- a) Totals/Gross Total of Prices should be indicated both in words as well as in figures. If there is a discrepancy between unit prices, total price quoted in words and figures, the Arithmetical errors will be rectified on the following basis.
- I. If there is a discrepancy between the unit price and the total price, which is obtained by multiplying the unit price and quantity, or between subtotals and the total price, the unit or subtotal price shall prevail, and the total price shall be corrected.
- II. If there is a discrepancy between words and figures, the amount in words shall prevail.
- b) In case of any other discrepancy, the decision of the purchaser will be final.

SPECIAL TERMS AND CONDITION

1. Unloading of material at site shall be in BHEL's scope.
2. Price in INR should be quoted for **F.O.R destination delivery at SDO STORE (S&T), O&M, GHTP, LM BATHINDA, DIST. BHATINDA – 151111, PUNJAB.**
3. **EVALUATION CRITERIA:** On total cost to BHEL (F.O.R site basis) for whole lot.
4. **TAXES AND DUTIES:**
Price quoted should be inclusive of all the applicable charges, Taxes and Duties. However rates of Entry Tax, Sales Tax, Excise Duty & other statutory levies should be indicated separately. Variation in Excise Duty, Sale Tax/ Vat or any other statutory levies during contractual delivery period shall be to BHEL's account.
 - a. **BHEL SHALL NOT ISSUE 'C' FORM** FOR SUPPLY OF MATERIALS FROM OUTSIDE PUNJAB.
 - b. **ROAD PERMITS IS NOT REQUIRED** FOR SUPPLY OF MATERIAL FROM OUTSIDE PUNJAB.
5. Excise duty actually incurred by seller/contractor on self-manufactured items against the dispatch made from his factory/works constituting a sale under the order, alone shall be reimbursed at actuals against requisite documentary evidence. The invoice cum excise duty gate pass (excise invoice) should contain the name of ultimate consignee as specified in the order. No excise duty shall be payable by purchaser on inputs, bought out items, raw materials and components consigned directly to site from sources other than seller/contractor's factory or works.
6. Quoted rates shall remain firm except for variation in Duties / Taxes as mentioned at serial no. 4 above.

INSPECTION, INSTALLATION & COMMISSIONING:

7. (I) **Inspection:** As per Clause 8.0 of Annexure – 1 of NIT.
(II) **Installation & Commissioning:** As per Clause 8.0 of Annexure – 1 of NIT.
8. **Delivery:** The delivery of Lock Blot machine shall be **within 8 WEEKS** from date of P.O. to the date of dispatch. "However Bidders are requested to quote delivery period according to their capacity. In case delivery period quoted by the bidder is not accepted by BHEL, then BHEL may reject their offer."

Note: Bidders are requested to arrange the transporters and dispatch the goods on our behalf on freight (including transit insurance) pre-paid basis. Goods to reach at destination within reasonable time say 10 days, however unloading shall be done by BHEL.

9. **VALIDITY OF OFFER:** Offers should be valid for a **period of 60 days from the** date of Techno-Commercial bid (Part-I) opening.

10. Documents to be submitted after P.O by the successful vendor before despatch :

As per Clause 11.0 of Annexure – 1 of NIT.

11. Tenderers shall elaborate on the service network and spare parts availability, which are to be ensured to maintain the equipment after initial commissioning and completion of warranty period. In case service/spare parts facilities are not available in India, tenderers shall indicate the maximum possible time in making such services available from places outside India.
12. The tenderers shall also provide free visits of their service engineer from manufacturer's works / service centers for attending the faults during the warranty period in case of any complaint by the end user.

13. The equipment being offered should be of robust design and suitable for operations in Indian climatic conditions such as saline atmosphere, ambient temperature up to 50 degrees Centigrade. The electrical and controls should be tropicalized to withstand such climatic conditions.

14. **Payment Terms:** Tenderer shall adhere to the following payment terms:-

- a) 90% of Ex-Works value with 100% taxes, duties, packing & forwarding and freight & insurance within 30 days of receipt of the material at destination.
- b) 10% of Ex-Works value shall be released within 30 days after successful Installation & Commissioning of Lock Bolt Machine at site & submission of all final documents including warranty cards, Test certificates, as applicable, Successful Installation & Commissioning certificate issued by BHEL and PBG as per clause 16 of STC.

A bank guarantee equal to **10% of the Order value excluding taxes & duties** valid up to 12 months from the date of date of Installation & Commissioning at site or 8000 hrs. of operation whichever is earlier shall be submitted at the time of claiming 10% final payment as per Sl. no. (b) Above.

The set of dispatch documents for 90% payment shall be as follows:-

- 1) Original tax Invoices
- 2) Copy of Packing List
- 3) Manufacturing Test certificate.
- 4) Warranty Certificate for the goods
- 5) Catalogue and O&M Manual (5 sets).
- 6) Certificate confirming, "Goods supplied are new".

NOTES:-

- (i) Tenderers are required to specifically confirm acceptance of these payment terms in their techno-commercial offer.
- (ii) No advance shall be paid.

15. **PAYING AUTHORITY:**

Manager /FINANACE, BHEL - PSNR, NOIDA

16. **Warranty:**

The **LOCK BOLT MACHINE** offered shall carry a warranty for a period of 12 months from the date of Installation & Commissioning at site or 8000 hrs. of operation whichever is earlier.

Rectification / replacement required during the warranty period will be arranged by the supplier free of cost including to and fro transport charges and import duty/excise duty/other taxes/insurance etc. payable on replacement items.

Supplier to submit the Performance Bank Guarantee (PBG) equivalent to **10% of the Order value excluding taxes & duties** which shall be valid up to 12 months from the date of Installation & Commissioning at site or 8000 hrs. of operation whichever is earlier.

17. No enhancement of Price, whatsoever the cause, will be allowed once the offer is accepted and the order is placed. Withdrawal of the offer after it is accepted or failure to make the supply within the schedule period will entail cancellation of purchase order and purchase at the risk and cost of supplier.

18. **REVERSE AUCTION:** "BHEL reserves the right to go for Reverse Auction (RA) instead of opening the sealed envelope price bid, submitted by the bidder. This will be decided after techno-commercial evaluation. All bidders to give their acceptance for participation in RA. Non-acceptance to participate in RA may result in non-consideration of their bids, in case BHEL decides to go for RA.

In case BHEL decides to go for Reverse Auction, only those bidders who have given their acceptance to participate in RA will be allowed to participate in the Reverse Auction. Those bidders who have given their acceptance to participate in Reverse Auction will have to necessarily submit „online sealed bid“ in the Reverse Auction. Non-submission of „online sealed bid“ by the bidder will be considered as tampering of the tender process and will invite action by BHEL as per extant guidelines in vogue.” **For details please refer to Annexure – 8.**

19. If any bidder belongs to **MSME** including SC/ST owned industry please clearly mention in your bid and provide supporting documents.

20. Order of Precedence:

In the event of any ambiguity or conflict between the Tender Documents, the order of precedence shall be in the order below:

- a. Amendments/Clarifications/Corrigenda/Errata etc issued in respect of the tender documents by BHEL
- b. Price Schedule – Annexure - 6
- c. Technical Specification — Annexure - 1

In case of any contradiction between General Terms & Conditions (GTC) and Special Terms & Conditions of Contract (STC), the latter shall prevail.

SR. ENGINEER/PURCHASE

GENERAL TERMS & CONDITIONS

1. Manufacturer's name, their trade mark and brand, if any should invariably be mentioned in the tender and illustrative leaflets in duplicate giving technical particulars etc. should be attached to the tender, to facilitate consideration of the offer.
2. Materials should be of best quality and correct to specifications, relevant DIN/ISO/ANSI standard or any other equivalent INTERNATIONAL standard specification as per technical specifications of tender.
3. Correct date of affecting supplies in the event of an order from this office should be recorded in the tender.
4. Please note that our terms of payment are as per clause 15 of "SPECIAL TERMS AND CONDITIONS".
All payments shall be done through Electronic Funds Transfer supplier shall submit bank details with bill invoices .In case of payment through, Bank all incidental charges will be to the Beneficiary's account.
5. Bharat Heavy Electricals Limited does not bind itself to accept the lowest tender, but reserves to itself the right to accept or reject all or part of any tender at its discretion.
6. No enhancement of rate, whatsoever the cause, will be allowed once the offer is accepted and the order is placed. Withdrawal of the offer after it is accepted or failure to make the supply within the schedule period will entail cancellation of purchase order and purchase at the risk and cost of supplier.
7. The quantities of each item to be purchased may vary according to actual requirement at the time of placement of order.
8. Where Sales Tax is payable extra, it will only be paid if registration numbers both under local sales tax/VAT and Central Sales Tax are specifically mentioned on the invoice. Tenderers should invariably quote their sales tax Registration No. in the offer.
9. **Liquidated Damages:** The LD shall be 0.5% of the total order value per week of delay or part thereof subject to a maximum of 10% of the total order value. In case of any amendment/revision, the LD shall be linked to the amended/revised PO value. **LR/ GR/ RR date for indigenous supplies shall be treated as the date of dispatch for levying LD.**
10. **Risk Purchase:** - Alternatively, the purchaser at his option, will be entitled to terminate the contract and to purchase elsewhere at the risk and cost of the seller either the whole or any part of the goods which the supplier fails to deliver or dispatch within the time stipulated as aforesaid, or if the same were not available, the best and the nearest available substitute therefore. The seller shall be liable for any loss, which the purchaser may sustain by reason of such risk purchase in addition to L.D. at the rate mentioned in clause 9 above.
11. **Inspection:** All goods and work are subject to our inspection either at manufacture's works or after delivery as may be agreed. The decision of BHEL shall be final. Rejected goods will be returned to the supplier at his cost including freight on original shipment.
12. **Insurance:** - Wherever specifically agreed to, the supplier will insure at his cost the goods for all transit risks. In all other cases, supplier must furnish particulars of dispatch i.e. station of dispatch and destination, name of the goods, number of cases and their weights, value of the goods including all taxes, duties, levies and freight etc. for each consignment immediately after the dispatch of goods. Failure to do this will make the supplier responsible for making good any loss which might have otherwise been recovered from insurers.

Note: However, the supplier shall still remain responsible for defective parts or short supply and defective packing.

13. **Metric System**: - Suppliers are requested to give metric measurements while quoting.
14. **Arbitration** : All disputes between the parties to the contract arising out of or in relation to the contract, other than those for which the decision of the Engineer or any other person is by the contract expressed to be final and conclusive, shall after written notice by either party to the contract to the other party, be referred to sole arbitration of the General Manager or his nominee. The arbitration shall be conducted in accordance with the provisions of the Arbitration and Reconciliation Act, 1996 the place of Arbitration shall be New Delhi (India).
15. Any suites in respect of this contract shall have the jurisdiction of the courts of New Delhi (India) only.

SR. ENGINEER/PURCHASE

ANNEXURE-“5”
UNPRICE FORMAT (TO BE SUBMITTED WITH TECHNICAL BID)

Sl. No.	DESCRIPTION	REMARKS
1.	SUPPLY, INSTALLATION & COMMISSIONING OF ONE NO. OF LOCK BOLT MACHINE (INCLUDING SPARE PARTS AS PER CLAUSE 7.0 OF ANNEXURE - 1). (QTY. = 1 NO.)	QUOTED IN PRICE BID
2.	PACKING AND FORWARDING CHARGES	QUOTED IN PRICE BID
3.	EXCISE DUTY & CESS (IF APPLICABLE AS PER CL 4 OF STC)	QUOTED IN PRICE BID RATE OF DUTY.....
4.	SALES TAX WITHOUT “C” FORM /VAT	QUOTED IN PRICE BID RATE OF TAX.....
5.	TRANSPORTATION / FREIGHT CHARGES & TRANSIT INSURANCE CHARGES FROM SUPPLIER’S WORK TO SDO STORE (S&T), O&M, GHTP, LM BATHINDA, DIST. BHATINDA – 151111, PUNJAB.	QUOTED IN PRICE BID
6	ANY OTHER TAXES/DUTIES APPLICABLE , IF ANY (PLEASE SPECIFY THE SAME)	QUOTED IN PRICE BID RATE OF DUTY/ TAX.....
7.	TOTAL ORDER VALUE ON F.O.R DESTINATION (SDO STORE (S&T), O&M, GHTP, LM BATHINDA, DIST. BHATINDA – 151111, PUNJAB) BASIS	QUOTED IN PRICE BID
8.	WARRANTY/GUARANTEE AS PER NIT	AGREED
9.	PAYMENT TERMS AS PER NIT	AGREED
10.	DELIVERY PERIOD AS PER NIT	AGREED
11.	VALIDITY OF PERIOD AS PER NIT	AGREED
12.	TEST CERTIFICATE / O&M MANUAL AS PER NIT	AGREED
13.	ANY OTHER INFORMATION	

NOTES:

- Tenders will be evaluated based on the prices quoted up to F.O.R Destination basis.** Bidders are requested to quote for each and every item from 1 to 7 as indicated above. **Please indicate NIL against items not applicable.**
- Please do not quote separate charges for Installation & Commissioning of the Machine at site.**
- Incomplete offer received may not be considered.
- The Rate shall be entered in figures as well as in words. In case of difference in rates between words and figures THE LESSER OF THE TWO will be treated as valid rate.
- In case of omission in quoting any rate, the evaluation will be done considering the highest quoted rate obtained against that item but the order, if placed, will be on the lowest quoted rate obtained against that item.
- Bidders are requested to arrange the transporter and dispatch the goods on our behalf on freight (Including transit insurance) pre-paid basis. Goods to reach at destination within reasonable time say 10 days.

(Signatures of the Bidder with Name, Designation & Company’s Seal)

ANNEXURE-"6"**PRICE SCHEDULE (TO BE SUBMITTED WITH PRICE BID)**

SL. NO.	DESCRIPTION	AMOUNT (Rs.)
1.	SUPPLY, INSTALLATION & COMMISSIONING OF ONE NO. OF LOCK BOLT MACHINE (INCLUDING SPARE PARTS AS PER CLAUSE 7.0 OF ANNEXURE - 1). (QTY. = 1 NO.)	
2.	PACKING AND FORWARDING CHARGES	
3.	EXCISE DUTY & CESS (IF APPLICABLE AS PER CL 4 OF STC)	
4.	SALES TAX WITHOUT "C" FORM /VAT	
5.	TRANSPORTATION / FREIGHT CHARGES & TRANSIT INSURANCE CHARGES FROM SUPPLIER'S WORK TO SDO STORE (S&T), O&M, GHTP, LM BATHINDA, DIST. BHATINDA – 151111, PUNJAB.	
6.	ANY OTHER TAXES/DUTIES APPLICABLE , IF ANY (PLEASE SPECIFY THE SAME)	
7.	TOTAL ORDER VALUE ON F.O.R DESTINATION (SDO STORE (S&T), O&M, GHTP, LM BATHINDA, DIST. BHATINDA – 151111, PUNJAB) BASIS	

NOTES:

- Tenders will be evaluated based on the prices quoted up to F.O.R Destination (BHEL-PSNR HQ/NOIDA) basis.** Bidders are requested to quote for each and every item from 1 to 9 as indicated above. **Please indicate NIL against items not applicable.**
- Please do not quote separate charges for Demonstration & Training of the instrument at BHEL/site.**
- Incomplete offer received may not be considered.
- The Rate shall be entered in figures as well as in words. In case of difference in rates between words and figures THE LESSER OF THE TWO will be treated as valid rate.
- In case of omission in quoting any rate, the evaluation will be done considering the highest quoted rate obtained against that item but the order, if placed, will be on the lowest quoted rate obtained against that item.
- Bidders are requested to arrange the transporter and dispatch the goods on our behalf on freight (Including transit insurance) pre-paid basis. Goods to reach at destination within reasonable time say 10 days.

(Signatures of the Bidder with Name, Designation & Company's Seal)

CERTIFICATE OF NO DEVIATION

(To be given in letterhead)

TENDER No. : BHEL/PSNR/SCP/CS/E-2538

I/ WE, M/s _____

HEREBY CERTIFY THAT NOT WITHSTANDING ANY CONTRARY INDICATIONS / CONDITIONS ELSEWHERE IN OUR OFFER DOCUMENTS, I/WE HAVE NEITHER SET ANY TERMS AND CONDITIONS NOR THERE IS ANY DEVIATION TAKEN FROM THE CONDITIONS OF BHEL'S TENDER SPECIFICATIONS, EITHER TECHNICAL OR COMMERCIAL, AND I/WE AGREE TO ALL THE TERMS AND CONDITIONS MENTIONED IN BHEL'S TENDER SPECIFICATION WITH ASSOCIATED AMENDMENTS & CLARIFICATIONS.

(Signatures of the Bidder with Name, Designation & Company's Seal)

REVERSE AUCTION (RA) FORMAT

BHEL reserves the right to go for a Reverse Auction (RA) instead of Opening the submitted sealed price bid, which will be decided after technical evaluation. Bidders are also required to furnish following details in their techno-commercial bid, for this purpose.

Information and general terms and conditions governing RA are given below.

In case BHEL decides to process the tender through Reverse Auction Process (RA), following details shall be required from the bidders for their authorized representative who will participate in the on line Reverse Auction Process;

- (a) Name of Designation of official:

- (b) Postal Address (Complete):

- (c) Telephone Nos. (Land line & Mobile both):

- (d) FAX No.:

- (e) E-mail address:

- (f) Name of Place/State/Country, wherefrom he will participate in the RA:

(Signatures of the Bidder with Name, Designation & Company's Seal)

TENDER NO: BHEL/PSNR/SCP/CS/ E-2538 Dtd. 27.01.2014
TERMS & CONDITIONS OF REVERSE AUCTION

Against this enquiry for the subject item/ system with detailed scope of supply as per enquiry specifications, BHEL may resort to "REVERSE AUCTION PROCEDURE" i.e., ON LINE BIDDING (THROUGH A SERVICE PROVIDER). The philosophy followed for reverse auction shall be English Reverse (No ties).

1. For the proposed reverse auction, technically and commercially acceptable bidders only shall be eligible to participate.
2. Those bidders who have given their acceptance for Reverse Auction (quoted against this tender enquiry) will have to necessarily submit „online sealed bid“ in the Reverse Auction. Non-submission of „online sealed bid“ by the bidder for any of the eligible items for which techno-commercially qualified, will be considered as tampering of the tender process and will invite action by BHEL as per extant guidelines in vogue.
3. BHEL will engage the services of a service provider who will provide all necessary training and assistance before commencement of on line bidding on internet.
4. In case of reverse auction, BHEL will inform the bidders the details of Service Provider to enable them to contact & get trained.
5. Business rules like event date, time, bid decrement, extension etc. also will be communicated through service provider for compliance.
6. Bidders have to fax the Compliance form before start of Reverse auction. Without this, the bidder will not be eligible to participate in the event.
7. In line with the NIT terms, BHEL will provide the calculation sheet (e.g., EXCEL sheet) which will help to arrive at "Total Cost to BHEL" like Packing & forwarding charges, Taxes and Duties, Freight charges, Insurance, Service Tax for Services and loading factors (for non-compliance to BHEL standard Commercial terms & conditions) for each of the bidder to enable them to fill-in the price and keep it ready for keying in during the Auction.
8. Reverse auction will be conducted on scheduled date & time.
9. At the end of Reverse Auction event, the lowest bidder value will be known on auction portal.
10. The lowest bidder has to fax/e-mail the duly signed and filled-in prescribed format for price breakup including that of line items, if required, as provided on case-to-case basis to Service provider within two working days of Auction without fail.
11. In case BHEL decides not to go for Reverse Auction procedure for this tender enquiry, the Price bids and price impacts, if any, already submitted and available with BHEL shall be opened as per BHEL's standard practice.
12. Bidders shall be required to read the "Terms and Conditions" section of the auctions site of Service provider, using the Login IDs and passwords given to them by the service provider before reverse auction event. Bidders should acquaint themselves of the „Business Rules of Reverse Auction“, which will be communicated before the Reverse Auction.
13. If the Bidder or any of his representatives are found to be involved in Price manipulation/ cartel formation of any kind, directly or indirectly by communicating with other bidders, action *as per extant BHEL guidelines*, shall be initiated by BHEL and the results of the RA scrapped/ aborted.
14. The Bidder shall not divulge either his Bids or any other exclusive details of BHEL to any other party.
15. In case BHEL decides to go for reverse auction, the H1 bidder(s) (whose quote is highest in online sealed bid) may not be allowed to participate in further RA process.

Formats for execution of Performance Bank Guarantees:

Note:- The Bank Guarantee bonds (BG) are to be submitted on non-judicial stamp paper of Rs. 100/- and should be only from any one of the below mentioned Banks, (1.State Bank of India, 2.State Bank of Hyderabad, 3.State Bank of Travancore, 4.State Bank of Mysore, 5.Canara Bank, 6.Bank of Baroda, 7.Punjab National Bank, 8.Deutsche Bank, 9.HDFC Bank, 10.Standard Chartered Bank, 11.Citi Bank, 12.Standard Chartered Grindlays Bank & 13.Bank of America)OR mutually agreed at the time of establishing the PBG

PERFORMANCE BANK GUARANTEE

1. In accordance of M/s Bharat Heavy Electricals Limited (A Government of India undertaking, a Company incorporated under the Companies Act 1956 having its Registered Office at 'BHEL House", SIRI Fort, New Delhi 110 049) through its Division namely Power Sector Northern Region (PSNR) located at Noida, Uttar Pradesh-201301 (hereinafter called "the Company") having entered into a contract with hereinafter called "the said contractor" which term includes 'suppliers' for the purpose of this Bond and under the terms and conditions of the Contract No: dtd..... between BHEL-PSNR, Noida and as per the contract, the contractor/supplier is to furnish a Performance Bank Guarantee for Rs..... for the due performance of the equipment to be supplied under the above referred contract and for the fulfillment of all the terms and conditions of the contract.
2. We (indicate the name of the Bank) (herein after referred to as the Bank) at the request of (contractor(s)) do hereby undertake to pay the Company an amount not exceeding Rs..... against any loss or damage caused to or suffered or would be caused to or suffered by the Company by reason of any breach by the said contractor (s) of any of the terms and conditions contained in the said agreement.
3. We (indicate the name of the Bank with full address), do hereby undertake to pay the amounts due and payable under this guarantee without any demur, merely on a demand from the Company stating that the amount claimed is due by way of loss or damage caused to or would be caused to or suffered by the Company by reason of breach by the said Contractor(s) of any of the terms and conditions contained in the said Agreement or by the reason of the contractor(s) 'failure to perform' the said Agreement. Any such demand made on the Bank shall be conclusive as regards the amount due and payable by the Bank under this guarantee. However, our liability under this guarantee shall be restricted to an amount not exceeding Rs.....
4. We undertake to pay unconditionally to the Company any money so demanded notwithstanding any dispute(s) raised by the Contractor in any suit, or proceedings pending before any Court or Tribunal or Arbitration or before any other authority relating thereto our liability under this present being absolute and unequivocal. The payment under this guarantee would not wait till the disputes have been decided by any Court or Tribunal or in the arbitration proceedings or by any other authority. The payment so made by us under this Bond shall be a valid discharge of liability for payment there under and the Contractor (s) shall have no claim against us for making such payment.
5. We (indicate the name of Bank), further agree that the guarantee herein contained shall remain in full force and effect during the period that

would be taken for the performance of the said Agreement and that it shall continue to be enforceable till all the dues of the Company under or by virtue of the said Agreement have been fully paid and its claim satisfied or discharged or till
Office/Department/Division of the Company certifies that the terms and conditions of the said Agreement have been fully and properly carried out by the said Contractor(s) and accordingly discharges this guarantee.

6. (i) Unless a demand or claim under this guarantee is made on us in writing on or before thewe shall be discharged from all the liability under this guarantee thereafter. But where such claim or demand has been preferred by the Company with the Bank before the expiry of the said date, the claim shall be enforceable notwithstanding the fact that the said enforcement is effected after the said date.

(ii) For the purpose of this clause, any letter making demand on the Bank by M/s BHEL will be dispatched by Registered Post with Ack. Due or by Telegram or by any Electronic media addressed to the above mentioned address of the Bank shall be deemed to be the claim/demand in writing referred to above irrespective of the fact as to whether and when the said letter reaches the Bank, as also any letter containing the said demand or claim is lodged with the Bank personally.

7. We(indicate the name of the Bank), further agree with the Company that the Company shall have the fullest liberty without our consent and without affecting in any manner our obligations hereunder to vary any of the terms and conditions of the said agreement or to extend time of performance by the said Contractor(s) from time to time or to postpone for any time of from time to time any of the powers exercisable by the Company against the said Contractor (s) and to forbear or enforce any of the terms and conditions relating to the said Agreement and we shall not be relieved from our liability by any reason of any such variation or extension being granted to the said contractor(s) or for any forbearance, act or omission on the part of the Company or any indulgence by the Company to the said Contractor(s) or by any such matter or thing whatsoever which under the law relating would, but for this provision, have effect of not so relieving us.

8. This guarantee will not be discharged due to the change in the constitution of the Bank or the Contractor(s).

9. It shall not be necessary for the Company to proceed against the contractor before proceeding against the guarantor-Bank and the guarantee herein contained shall be enforceable against them notwithstanding any security, which the Company may have obtained or obtain from the Contractor shall, at the time when proceedings are taken against the guarantor hereunder be outstanding or unrealized.

10. Any claim or dispute arising under the terms of this document shall only be enforced or settled in the Courts at Delhi.

11. The guarantor hereby declare that it has power to execute this guarantee and the executants has full powers to do so on its behalf under the proper authority granted to him /them by the guarantor.

12. We.....(indicate the name of Bank) lastly undertake not to_revoke this guarantee during its currency except with the previous consent of the Company in writing.
In witness where of we (indicate the name of Bank) have_here unto set out Bank Seal
the Day month 20