



BHARAT HEAVY ELECTRICALS LIMITED

TRANSMISSION BUSINESS ENGINEERING MANAGEMENT

DOCUMENT No.	TB 329 316 008	REV. NO.	00	Prepared	Checked	Approved
TYPE OF DOC.	TECHNICAL SPECIFICATION	NAME	NK	SK/DKM	RS	
TITLE		SIGN		<i>[Signature]</i>	<i>[Signature]</i>	<i>[Signature]</i>
220kV AND 33kV OUTDOOR CIRCUIT BREAKER		DATE	04.02.13	06.02.13	06.02.13	25/02/13
		GROUP	TBEM	W.O. No	89004	
		CUSTOMER	NHPC LIMITED, FARIDABAD			
PROJECT	220/33KV SWITCHYARD FOR KISHANGANGA (3X110MW) HEP					
KISHANGANGA CONSORTIUM:	HINDUSTAN CONSTRUCTION COMPANY (HCC) LTD. HALCROW SUBCONTRACTOR: BHARAT HEAVY ELECTRICALS LTD.					
CONSULTANT	HALCROW NOIDA					

CONTENTS

<u>SL. NO.</u>	<u>TITLE</u>	<u>PAGE</u>
1.	SECTION-1: SCOPE, SPECIFIC TECHNICAL REQUIREMENTS & QUANTITIES	5
2.	SECTION-2: GENERAL ELECTRICAL SPECIFICATION	14
3.	SECTION-3: PROJECT DETAILS AND GENERAL SPECIFICATIONS + NHPC Specification	16+15=31
4.	SECTION-4: GUARANTEED AND TECHNICAL PARTICULARS	14
5.	SECTION-5: MANUFCAURING QUALITY PLAN	8
6.	CHECK LIST	3

COPYRIGHT & CONFIDENTIAL
 The Information in this document is the property of BHARAT HEAVY ELECTRICALS LIMITED
 This must not be used directly or indirectly in anyway detrimental to

Rev No.	Date	Altered	Checked	Approved	REVISION DETAILS		
Distribution				To	TBCM	OC	
				Copies	1	1	

SECTION 1

SCOPE, SPECIFIC TECHNICAL REQUIREMENTS AND QUANTITIES.

1.0 SCOPE

This technical specification covers the requirements of design, manufacture, testing at works, packing and dispatch of 220kV and 33kV Circuit Breakers complete with accessories as listed in clause 1.2 & 1.3 below.

This section covers the specific technical requirements of SF6 Circuit Breakers. In case of any discrepancies between the requirements mentioned in this section and those specified in the following sections of this specification, the specifications given herein shall prevail and shall be treated as binding requirements.

1.1 The equipment is required for the following project.

Name of Customer : NHPC Ltd.

KISHANGANGA CONSORTIUM:

Hindustan Construction Company (HCC) Ltd. / HALCROW

Subcontractor: Bharat Heavy Electricals Ltd.

Name of Consultant : HALCROW Noida

Name of the project : 220/33kV Switchyard for Kishanganga (3x110MW) HEP

Refer Section - 3 for Project Details and General Specifications.

1.2 SPECIFIC TECHNICAL REQUIREMENTS

Since this switchyard is situated at an altitude of 1795M above MSL, the equipment shall be suitable for increased insulation level with an altitude correction factor of 1.1 times the normal values and shall be suitable for operation under prescribed conditions.

[The values of Impulse withstand Voltage & power frequency withstand voltage given in specific technical requirement below have been increased for the higher altitude taking a correction factor of 1.1].

Further the equipment being supplied shall be suitable for operation under sub zero temp, with ice/snow considerations. The equipment shall be suitable for working in the temperature variation between (-) 12degree C to (+) 38degree C without reporting any malfunction.

The circuit breakers shall be as per following technical parameters:

SN	Description	220kV	33kV
1.	Highest System Voltage	245kV	36kV
2.	Rated continuous current	1250 A	630 A
3.	Rated frequency	50 Hz	50 Hz
4.	No. of poles	3	3
5.	Rated symmetrical short circuit breaking current	31.5kArms	12.5kArms
6.	Rated asymmetrical short circuit breaking current	35kArms	14kArms
7.	Rated short time withstand current	79kAp	31.5kAp
8.	Rated short circuit making current	79kAp	31.5kAp

220/33kV Switchyard for Kishanganga (3x110MW) HEP for NHPC Limited

Technical Specification Doc.No. TB 329 316 008 Rev.00

220kV & 33kV Outdoor Circuit Breaker

	Rated insulation level		
9	Full wave impulse withstand voltage (1.2/50 μ s)		
9.1	Between line terminal & ground	\pm 1155 kVp (1050 kVp x1.1)	\pm 187 kVp (170kVp x1.1)
9.2	Between terminals with breaker contacts open	\pm 1320 kVp (1200 kVp x1.1)	\pm 187 kVp (170kVp x1.1)
10	One minute power frequency dry and wet withstand voltage		
10.1	Between line terminal & ground	506 kV rms (460kV rms x1.1)	77kV rms (70kV rms x1.1)
10.2	Between terminals with breaker contacts open	583kVrms (530 kV rmsx1.1)	77kV rms (70kV rms x1.1)
11	Max. radio interference Voltage (microvolts) for frequency between 0.5 MHz and 2 MHz at 156 kVrms for 220 kV in all positions of the Equipments	1000	-
12.	Minimum Creepage distance	6125 mm	900
13.	Seismic acceleration	0.36g horizontal	
14.	System neutral earthing	Effectively Earthed	
15.	Phase to phase spacing	4500mm	1500mm
16.	Minimum clearance in air		
16.1	Live part to earth	2300mm	480mm
16.2	Between phases	2700mm	530mm
16.3	Live parts to ground level	4300mm	2800mm
16.4	Centre to centre distance between the adjacent phase unit of the breaker	4300mm	2800mm
17	Line charging current breaking capability	125A	As per IEC
18	Small inductive current breaking capability (Without producing excessive over voltage)	250A	As per IEC
19	Number of quenching chambers	1	1
20	Operating sequence	O-.3sec-CO-3min-CO	O-.3sec-CO-3min-CO
21	Mechanical opening time	< 42ms	< 42ms
22	Total breaking time	< 60ms	< 60ms
23	Total closing time	Up to 150ms	Up to 150 ms
24	First pole to clear factor	1.3	-
25	Reclosing	Single phase and three phase auto reclosing	-
26	Operating mechanism	Pneumatic / spring	Spring
27	Type of quenching medium	SF6	Vacuum/SF6
28	Auxiliary contacts	Beside requirement of this specification, bidder shall provide 10 NO + 10 NC	

		contacts for owner's future use
30	Rating of auxiliary contracts	10 A at 220 V DC
31	Breaking capacity of auxiliary contacts	2 A DC with circuit time constant of not less than 20 ms
32	Trip coil and closing coil voltage	220V DC
33	No. of terminals in common control cabinet	All contacts circuits are to be wired out up to common control cabinet plus 24 terminals exclusively for owner's use.

1.3 QUANTITIES

S N	Description	Qty
1	220 KV, 1250 A, 31.5 kA for 1 sec , SF6, 3 Phase gang Operated Circuit Breakers, Pneumatic/ Spring Charged mechanism with single and three phase auto reclosing complete with all accessories as per clause no. 1.3.1	09 Nos.
2	33 KV, 630 A, 12.5 kA for 1 sec , Vacuum/SF6, 3 Phase gang operated Circuit Breakers, Spring Charged mechanism complete with all accessories as per clause no. 1.3.1	04 Nos.
3	One complete pole of 220kV Circuit Breaker with interrupter unit, support insulators, operating mechanism and tie rod etc.	1 No.
4	Trip Coils for 220kV circuit Breakers	6 Nos.
5	Closing coils for 220kV Circuit Breaker	6 Nos.
6	Complete set of rupture disc for one no. 220kV Circuit Breaker	2 sets
7	Vacuum bottle OR SF6 gas interrupter for 33kV Circuit Breaker	3 Nos.
8	Trip & Closing coils for 33kV Circuit Breaker	4 Sets
9	Spare SF6 Gas (20% of total gas used for above circuit breakers)	1 Lot
10	Handling devices & tools for assembling and dismantling the operating mechanisms of 220kV & 33kV Circuit Breakers *	1 Set
11	Supervision of Erection ,Testing & Commissioning of one no. 220kV Circuit Breakers as per clause no. 1.3.2	09 Nos.
12	Supervision of Erection ,Testing & Commissioning of one no. 33kV Circuit Breakers as per clause no. 1.3.2	04 Nos.

* Bidder to quantify all the items taken against BOQ sr. no. 10 and to provide the details of each one.

1.3.1 Accessories:

Each Circuit Breaker (220kV and 33kV) shall be supplied with following accessories as required for the satisfactory operation of the breaker.

- i) Support Structure
- ii) Interpole cabling, pipes, cable tray of associated size, etc.
- iii) Gas filling adaptor.
- iv) Foundation bolts.
- v) Any other accessory/device required for the satisfactory operation of the breaker.

1.3.2 Supervision terms & conditions:

The Supervision of testing and commissioning shall be inclusive of the following:

- i. The following instruments/kits shall be brought out at site by supplier.
 - a) Time interval meter (Timing kit)
 - b) Gas leak detector
 - c) SF6 Gas filling & evacuating device (Portable)
- ii. To and Fro fares from Bidder's headquarter to BHEL site.
- iii. Accommodation and conveyance at site.
- iv. Any other incidental charges.
- v. No other charges shall be paid by BHEL.
- vi. The following instruments/kits shall be arranged at site by BHEL.
 - a) Circuit Breaker analyzer (Make Scope T&M HISAC 2406)-
Adaptor/transducer for above analyzer suitable for your breaker shall be in the bidder's scope.
 - b) DCRM
 - c) Dew point meter
 - d) Megger
 - e) Multimeter

1.4 TYPE TESTS

The Circuit Breaker should have been type tested as per relevant IEC/IS including the followings:

- a) Higher insulation levels due to higher altitude (1795 M from MSL) –
Circuit Breaker need to withstand higher Impulse levels and higher one minute power frequency withstand voltage as specified in clause 1.2 of this Section.
- b) Operation under severe ice loading condition -
Circuit breaker shall be able to operate in the 10mm ice loaded condition at (-) 12 Degree C temperature (Clause no. 6.101.5 of IEC 62271-100).

- 1.5 At contract stage, the reports for all type tests including higher insulations and Ice loading as per technical specification shall be submitted for BHEL/NHPC approval. The type tests conducted earlier should have either been conducted in accredited laboratory (accredited base on ISO / IEC Guide 25 / 17025 or EN 45001 by the national accreditation body of the country where laboratory is located) or witnessed by the representatives(s) of NHPC or Utility. The test reports submitted shall be of the tests conducted within last 5 (five) years prior to the date of bid opening. In case In case the test reports are of the test conducted earlier than 5 (five) years prior to the date of bid opening, the bidder shall repeat these test(s) at no extra cost to the purchaser. **Date of Bid opening is 22.01.09.**

In the event of any discrepancy in the test reports i.e. any test report not acceptable to NHPC due to any design / manufacturing changes (including substitution of components) or due to non-compliance with the requirement stipulated in the Technical Specification on any/all additional type tests not carried out, same shall be carried out without any additional cost implication to the Purchaser.

1.6 SHOP TEST

Circuit breaker shall be routine tested at supplier's works as per relevant IEC. The following shop tests shall be carried out at manufacturer's works:

- i) Mechanical Operation

- ii) Measurement of speed, time and travel contact
- iii) Measurement of contact resistance
- iv) Power frequency withstand test
- v) Coil resistance test
- vi) Anti pumping check
- vii) Functional & wiring check.

1.7 MINIMUM TECHNICAL QUALIFYING REQUIREMENT

The bidder should have designed, manufactured, type tested as per IEC/IS or equivalent standard and supplied the similar ratings of Circuit Breakers during last ten (10) years. The equipment so manufactured should have been successfully commissioned at least at three power stations/sub-stations.

1.8 MANUFACTURING QUALITY PLAN

Quality Assurance Plan (Model) for SF6 & Vacuum Circuit Breaker (Enclosed at section-V) shall be followed.

1.9 CHECK LIST

Duly filled and signed checklist shall be submitted along with the offer, in the absence of which, offer may not be considered for evaluation.

SECTION-2 EQUIPMENT SPECIFICATION

2.1 General

This section covers the general technical requirements of the outdoor type SF₆ circuit breakers..

2.2 Applicable Standards

The circuit breakers shall strictly conform to the following Indian and International standards as appropriate:

1. IEC 62271-100 Specification for high voltage switchgear & control gear.
2. IEC 376 : 1971 Specification and acceptance of new sulphur hexafluoride, mineral oil content, second supplement
3. IEC 56 (1987) Specification for high voltage alternating-current circuit breaker.
4. IS 13947 (Part 1) : 1993 Low voltage switchgear and control gear, General rules
IS 13947 (Part 2) : 1993 Low voltage switchgear and controlgear, Circuit Breakers.
5. IS 325 : 1978 Three phase induction motors.
6. IS 2629 : 1985 Recommended practice for hot dip galvanizing on iron and steel.
7. IEC 694 : 1980 Common clauses for high voltage switchgear and controlgear standards
8. IEC 71 (Part 1) : 1993 Insulation coordination, Definition Principle and rules
IEC 71 (Part 2) : 1976 Insulation coordination, Application Guide
9. CIGRE WG Report No. 13-02-1973 Switching over-voltage in EHV and UHV systems with special reference to closing and re-closing transmission lines

10.	IS 2633 : 1986	Method for Testing Uniformity of coating on zinc coated articles.
11.	IS 2544 : 1973	Specification for Porcelain Post Insulators for systems with nominal voltages greater than 1000 volts.
12.	IS 5561 : 1970	Electric Power Connectors.
13.	IS 5621 : 1980	Hollow insulators for use in electrical equipments.
14.	IEC 233 : 1974	Tests on hollow insulators for use in Electrical Equipment.
15.	IS 4379 : 1981	Identification of contents & industrial gas cylinders.
16.	IS 7285 : 1988	Seamless steel cylinders for permanent and high pressure liquifiable gases.

Latest version of all standards shall be considered.

2.3 Duty Requirements :

- 2.3.1 The circuit breaker shall be re-strike free as per IEC under all duty conditions and shall be capable of performing their duties without opening resistors.
- 2.3.2 The circuit breaker shall meet the duty requirements for any type of fault or fault location also for line switching when used on a effectively grounded system, and perform make and break operations as per the stipulated duty cycles satisfactorily.
- 2.3.3 The breaker shall be capable of interrupting the steady state and transient magnetizing current corresponding of power transformers.
- 2.3.4 The circuit breaker shall also be capable of :
- i) Clearing short line fault (kilometric faults) with source impedance behind the bus equivalent to symmetrical fault current specified.
 - ii) Interrupting line/cable charging current as per IEC without any restrikes and without use of opening resistors.
 - iii) Breaking small inductive current of 0.5 to 10A without switching over voltage exceeding the limits specified in IEC.
 - iv) Breaking 25% of the rated fault current at twice rated voltage under phase opposition condition.

2.3.5 The Breakers shall satisfactorily withstand the high stresses imposed on them during fault clearing, load rejection and re-energisation of lines with trapped charges. The breaker shall also withstand the voltages specified in this specification.

2.4 TOTAL BREAK TIME:

2.4.1 The total break time as specified under section 1 of this specification shall not be exceeded under any of the following duties :

- (i) Test duties 1, 2, 3, 4, 5 (TRV as per IEC-56)
- (ii) Short line fault L75, L90 (TRV as per IEC-56)

2.4.2 The Bidder may please note that total break time of the breaker shall not be exceeded under any duty conditions specified such as with combined variation of the trip coil voltage, (70-110%), pneumatic/hydraulic pressure and arc extinguishing medium pressure etc. While furnishing the proof of the total break time of complete circuit breaker, the Bidders may specifically bring out the effect of non-simultaneity between contacts within a pole or between poles and show how it is covered in the guaranteed total break time.

2.4.3 The values guaranteed shall be supported with type test reports.

2.5. CONSTRUCTIONAL FEATURES:

The features and constructional details of circuit breakers shall be in accordance with requirements stated here under:

2.5.1 All making and breaking contacts shall be sealed and free from atmospheric effects. Contacts shall be designed to have adequate thermal and current carrying capacity for the duty specified and to have a life expectancy so that frequent replacement due to excessive burning will not be necessary. Provision shall be made for rapid dissipation of heat generated by the arc on opening.

2.5.2 Any device provided for voltage grading or to limit over-voltages on closing shall have a life expectancy comparable to that of the breaker as a whole.

2.5.3 Breakers shall be so designed that when operated within their specified rating, the temperature of each part will be limited to values consistent with a long life for the material used. The temperature shall not exceed that indicated in IEC-56 under specified ambient conditions.

2.5.4 The gap between the open contact shall be such that it can withstand at least the rated phase to ground voltage for 8 hours at zero gauge pressure of SF6 gas due to the leakage. The breaker should be able to withstand all dielectric

stresses imposed on it in open condition at lock out pressure continuously (i.e. 2 p.u. across the breaker continuously).

2.5.5 If multi-break interrupters are used these shall be so designed and augmented that a uniform voltage distribution is developed across them. Calculations/test reports in support of the same shall be furnished. The thermal and voltage withstands of the grading elements shall be adequate for the service conditions and duty specified.

2.5.6 The SF6 circuit breaker shall meet the following additional requirements:

- a) The circuit breakers shall be single pressure type. The design and construction of the circuit breaker shall be such that there is a minimum possibility of gas leakage and entry of moisture. There should not be any condensation of SF6 gas on the internal insulating surfaces of the circuit breaker.
- b) All gasketed surfaces shall be smooth, straight and reinforced, if necessary, to minimize distortion and to make a tight seal, the operating rod connecting the operating mechanism to the arc chamber (SF6 media) shall have adequate seals. The SF6 gas leakage should not exceed 1% per year. In case the leakage under the specified condition is found to be greater than 1% after one year of commissioning of circuit breaker, the manufacturer will have to supply free of cost, the total gas requirement for subsequent ten(10) years, based on actual leakage observed during first year of operation after commissioning.
- c) In the interrupter assembly there shall be an absorbing product box to minimize the effect of SF6 decomposition products and moisture. The material used in the construction of the circuit breakers shall be such as fully compatible with SF6 gas decomposition products.
- d) Each pole shall form an enclosure filled with SF6 gas independent of two other poles, the SF6 density of each pole shall be monitored.
- e) The dial type SF6 density monitor shall be adequately temperature compensated to model the pressure changes due to variations in ambient temperature within the body of circuit breaker as a whole. The density monitor shall have graduated scale and shall meet the following requirements :
- f) It shall be possible to dismantle the density monitor for checking/replacement without draining the SF6 gas by providing suitable interlocked non return valve coupling.
- g) Each circuit breaker shall be capable of withstanding a vacuum of minimum 8 milibars without distortion or failure of any part.

- h) Sufficient SF6 gas including that will be required for gas analysis during filling shall be provided to fill all the circuit breakers installed. In addition spare gas shall be supplied in separate unused cylinders as per requirement specified.

2.5.7 Provisions shall be made for attaching an operational analyzer after installation of circuit breakers at site to record contact travel, speed and making measurement of operating timings, synchronization of contacts in one pole. In case operation analyzer is already available at a particular site, the contactor shall have to supply a suitable adopter/transducer so that the offered circuit breaker can be used with the operational analyzer.

2.5.8 Terminal Connector Pad

The circuit Breaker terminal pad shall be made up of high quality electrolytic copper or aluminium. The terminal pad shall have protective covers which shall be removed before interconnections.

2.5.9 The circuit breaker shall be designed to withstand the rated terminal loads, wind load/ earthquake load, short circuit forces.

2.5.10 The Vacuum circuit breaker shall meet the following additional requirements:

VACUUM INTERRUPTER(VI) :-

- i) The design of the vacuum interrupter shall be such that it gives trouble free operation under normal load and fault conditions throughout the life of the equipment. As the efficiency of the breaker depends on the degree of vacuum inside the interrupter, manufacturer shall ensure that the same is maintained consistently during service. To know the residual life of vacuum interrupter, an indicator/means to indicate status of contact erosion should be provided.
- g) The insulating ceramic body of the interrupter should have high mechanical strength and it should be capable of withstanding high temperature without any significant deterioration in its mechanical and electrical properties.
- h) The metal/alloy used for the fixed and moving contacts shall have very low resistivity and low gas content. They should be resistant to arc erosion and the contact should have no tendency to get Cold Welded under the high vacuum in the interrupter.
- i) The interrupter design should ensure rapid de-ionization of the gap so that normal electrical strength of the gap is restored instantaneously.
- j) The metallic bellow or any other similar vacuum sealing arrangement should be provided at the moving contact and should have a long fatigue life.
- k) Manufacturers catalogue of vacuum bottle, indicating all the details shall essentially be submitted.
- l) A pressure gauge to monitor positive pressure lower part of the pole is to be provided to protect ingress of moisture.

2.6 SULPHUR HEXAFLUORIDE GAS (SF6 GAS):

- 2.6.1 Sufficient SF6 gas including that required for gas Analysis during filling shall be provided to fill all the circuit breakers installed. In addition 20% of total gas requirement shall be supplied in separate cylinders as spare requirement.
- 2.6.2 The SF6 gas shall comply with IEC 376, 376A and 376B and shall be suitable in all respects for use in the switchgear under the operating conditions.
- 2.6.3 The high pressure cylinders in which the SF6 gas is shipped and stored at site shall comply with requirements of the relevant standards and regulations.
- 2.6.4 SF6 gas shall be tested for purity, dew point, air, hydrolysable fluorides and water content as per IEC 376, 376A and 376B and supplier's test certificates shall be furnished indicating all the tests as per IEC 376 for each lot of SF6 gas in stipulated copies as indicated in Sec.-3 of this specification. Gas bottles should be tested for leakage during receipt at site.

2.7 INSULATORS:

- a) The porcelain of the insulators shall conform to the requirements stipulated under this specification as applicable.
- b) The mechanical characteristics of insulators shall match with the requirements specified under this specification.
- c) All insulators shall conform to IEC 61264(for pressurized hollow column insulators) and IEC-233 (for others). All routine and sample tests shall be conducted on the hollow column insulators as per these standards with requirements and procedures modified as under :
 - i) Pressure test as a routine test
 - ii) Bending load test as a routine test
 - iii) Bending load test as a sample test on each lot
 - iv) Burst pressure test as a sample test on each lot
 - v) In addition to above, ultrasonic test shall be carried out as additional routine test.
- d) Hollow Porcelain for pressurized columns/chambers should be in one integral piece in green and fired stage.

2.8 SUPPORT STRUCTURE :

Support structures for Circuit Breaker and central Control cabinet shall be hot dip galvanized. These support structures along with foundation bolts shall be supplied by the Supplier.

The support structure of the circuit breaker shall meet the following mandatory requirement :

The minimum vertical distance from the bottom of the lowest porcelain part of the enclosures to the circuit breaker base, where it rests on the foundation pad shall be 2.55 metres.

The structure design shall be such that during operation of circuit breaker vibration are reduced to minimum.

If required, the contractor shall provide suitable platform with steps on both sides of the circuit breaker for easy accessibility for monitoring the density/pressure of gas.

The support structure shall also meet the other requirements given under this specification.

2.9 OPERATING MECHANISM AND CONTROL

2.9.1 General Requirements:

Circuit breaker shall be operated by pneumatic mechanism or spring charged mechanism or hydraulic mechanism or a combination of these. The mechanism shall be housed in a weather proof and dust proof control cabinet as stipulated under this specification..

The operating mechanism shall be strong, rigid, not subject to rebound and shall be readily accessible for maintenance for a man standing on ground.

The operating mechanism shall be suitable for high speed reclosing and other duties specified. During reclosing the breaker contacts shall close fully and then open. The mechanism shall be anti-pumping and trip free (as per IEC definition) under every method of closing. The mechanism of the breaker shall be such that the position of the breaker is maintained even after the leakage of operating media and/or SF6 gas.

The mechanism shall be such that the failure of any auxiliary spring will not prevent tripping and will not cause trip or closing operation of the power operating devices.

A mechanical indicator shall be provided to show open and close position of the breaker. It shall be located in a position where it will be visible to a man standing on the ground level with the mechanism housing closed. An operation counter shall also be provided in the central control cabinet.

Working parts of the mechanism shall be corrosion resisting material, bearings which require grease shall be equipped with pressure type grease fittings. Bearing pin, bolts, nuts and other parts shall be adequately pinned or locked to prevent loosening or changing adjustment with repeated operation of the breaker.

The pole control cabinet and central control cabinet shall comply with requirements specified under this specification.

The bidder shall furnish detailed operation and maintenance manual of the mechanism along with the operation manual for the circuit breaker. The instruction manuals shall contain exploded diagrams with complete storage, handling, erection, commissioning, troubleshooting, servicing and overhauling instructions.

2.9.2 General Requirements (Vacuum CB):

The circuit breaker shall be designed for remote control from the control room and in addition there shall be provision for manual operation of circuit breakers during maintenance and for local tripping and closing by the normal means.

The circuit breakers shall have operation control and mechanical "open" and "closed" indicator, in addition to facilities for remote electrical indication. An operation counter shall also be provided in the common operating mechanism. The mechanical indicator and operation counter shall be located in a position where it shall be visible to a man standing on the ground level with the mechanism housing doors are in closed position. In addition to mechanical indications, the electrical On/Off indication is also to be provided.

The operating mechanism shall be of the spring charging type, by electric control under normal operation. The mechanism shall be trip free electrically and mechanically. The mechanism shall also be capable of performing satisfactorily, the re-closing duty cycles. All working parts in the mechanism shall be of corrosion resistant material and all bearings which require greasing shall be equipped with pressured grease fittings. No part/component shall be of non metallic materials so mechanical strength of the mechanism shall be ensured. The mechanism shall be strong, quick in action and shall be removable without disturbing the other parts of the circuit breaker. The mechanism and breaker shall be such that the failure of any spring will not prevent tripping and will not cause tripping or closing. The operating Mechanism should be motor operated spring charged type. The Motor should have overload protection. Provision should also be made for mounting of Mechanism Box at an adequate height and gear ratios shall be so chosen that one man should be able to charge the spring, without any additional efforts. The mechanical arrangement should be provided to facilitate manual tripping of circuit breaker for emergency trip under emergent condition i.e. failure of DC supply, trip coil burnt, mechanism is defective while arc quenching media is healthy. The operating mechanism shall be capable to perform 10000 trouble free mechanical operations .

2.9.2 CONTROL

The close and trip circuit shall be designed to permit use of momentary contact switches and push buttons.

Each breaker pole shall be provided with two (2) independent tripping circuits, pressure switches and coils each connected to a different set of protective relays.

The breaker shall normally be operated by remote electrical control. Electrical tripping shall be performed by shunt trip coils. However, provisions shall be made for local electrical control. For this purpose a local/remote selector switch and close and trip control switch/push buttons shall be provided in the Breaker central control cabinet.

The trip coils shall be suitable for trip circuit supervision during both open and close position of breaker.

Closing coil and associated circuit shall operate correctly at all values of voltage between 85% and 110% of the rated voltage. Shunt trip coil and associated circuits shall operate correctly under all operating conditions of the circuit breaker up to the rated breaking capacity of the circuit breaker and at all values of supply voltage between 70% and 110% of rated voltage. However, even at 50% of rated voltage the breaker shall be able to operate. If additional elements are introduced in the trip coil circuit their successful operation and reliability for similar applications on outdoor circuit breakers shall be clearly brought out in the additional information schedules.

Density meter contacts and pressure switch contacts shall be suitable for direct use as permissive in closing and tripping circuits. Separate contacts have to be used for each of tripping and closing circuits. If contacts are not suitably rated and multiplying relays are used then fail-safe logic/schemes are to be employed. DC supplies for all auxiliary circuits shall be monitored and provision shall be made for remote annunciation and operation lockout in case of DC failures. Density monitors are to be so mounted that the contacts do not change on vibration during operation of circuit breaker.

The auxiliary switch of the breaker shall be positively driven by the breaker operating rod. The auxiliary switch shall conform to the requirements of this specification.

The preferred basic control schematic of the circuit breaker shall be furnished to the successful bidder and it is expected to be followed by the bidder. This, however, does not absolve the bidder from the responsibility for safe and reliable operation of the breaker in its lifetime.

2.9.3 Spring - Operated Mechanism

- a) Spring operated mechanism shall be complete with motor in accordance with the specification.. Opening spring and closing spring with limit switch for automatic charging and other necessary accessories to make the mechanism a complete operating unit shall also be provided.

- b) As long as power is available to the motor, a continuous sequence of the closing and opening operations shall be possible. The motor shall have adequate thermal rating for this duty. The motor shall meet the requirements specified in the specification.
- c) After failure of power supply to the motor, one close open operation shall be possible with the energy contained in the operating mechanism.
- d) Breaker operation shall be independent of the motor which shall be used solely for compressing the closing spring. Facility for manual charging of the closing spring shall also be provided. The motor rating shall be such that it requires not more than 30 seconds for full charging of the closing spring.
- e) Closing action of circuit breaker shall compress the opening spring ready for tripping.
- f) When closing springs are discharged after closing a breaker, closing spring shall be automatically charged for the next operation and an indication of this shall be provided in the local and remote control cabinet.
- g) Provisions shall be made to prevent operation of the breaker when the spring is in the partial charged condition. Mechanical interlocks shall be provided in the operating mechanism to prevent discharging of closing springs when the breaker is already in the closed position.
- h) The spring operating mechanism shall have adequate energy stored in the operating spring to close and latch the circuit breaker against the rated making current and also to provide the required energy for the tripping mechanism in case the tripping energy is derived from the operating mechanism.

2.9.4 Pneumatically - Operated Mechanism

- a) Each pneumatic operated breaker shall be equipped with compressed air system in accordance with clause 2.11.
- b) The breaker local air receivers shall comply with the requirements under clause 2.11.4 and shall have sufficient capacity for at least two CO operations of the breaker at the lowest pressure for auto reclosing duty without refilling.
- c) Independently adjustable pressure switches with potential free, ungrounded contacts to actuate a lockout device shall be provided. This lockout device with provision of remote alarm indication shall be incorporated in the circuit breaker to prevent operation whenever the pressure of the operating mechanism is below that required for satisfactory operation of the circuit breaker. The scheme should permit operation of all blocking and alarm relays as soon as the pressure transient present during

the rapid pressure drop has been damped and a reliable pressure measurement can be made. Such facilities shall be provided for following conditions:

- i) Trip Lockout pressure - 2 Nos.
 - ii) Close Lockout pressure - 1 No.
 - iii) Auto reclose Lockout pressure - 1 No.
 - iv) Extreme low pressure - 1 No.
- d) The compressed air mechanism shall be capable of operating the circuit breaker under all duty conditions with air pressure immediately before operation between 85% and 110% of the rated supply pressure. The make/break time at this supply pressure shall not exceed the specified make/break time within any value of trip coil supply voltage as specified.
- e) The compressed air piping shall comply with clause 2.11.

2.10 UNIT COMPRESSED AIR SYSTEM FOR CIRCUIT BREAKERS

2.10.1 The unit compressed air system shall meet the following requirements :

- a) The compressed air system shall be provided with necessary piping, piping accessories, control valves, safety valves, filter reducing valves, isolating valves, drain ports, etc. Also the Unit compressed air system shall be provided with suitable ant-vibration pads.
- b) The compressor or pumps shall be of the air cooled type and mounted within the operating mechanism housing or a separate weather-proof and dust-proof housing.
- c) The air receiver shall have stored energy for 2 CO operations of the breaker at the blocking pressure for auto-reclosing duty without refilling. The unit compressor shall be capable of building up required pressure for another 2 CO operations within 30 minutes.
- d) The size of the compressor shall be determined by the bidder. The compressor shall be of sufficient capacity for performing all the operations above mentioned.

2.10.2 Air Compressor

- a) The air compressor shall be of air cooled type complete with cylinder lubrication, drive motor etc. The compressor shall be rated for the following duty :
 - i) Total running time of compressor to build up the rated pressure from atmospheric pressure - Not exceeding 80 minutes

- | | |
|---|--|
| ii) Normal running air charging | Not exceeding 15 minutes considering 10% leakage/day |
| iii) Air charging time after one close-open operation from rated pressure | Not exceeding 15 minutes |
- b) Compressor shall be driven by automatically controlled motors conforming to requirements given under this specification.
- c) The compressor shall be provided with automatic adjustable unloading device during starting.
- d) The compressor shall be equipped with a Time totaliser and a Pressure gauge.

2.10.3 Intercooler and After cooler : (if applicable)

Intercooler between compressor stage and after cooler at discharge if any of H.P. cylinder shall be included in Contractor's scope. They shall be of air cooled type and shall be designed as per ASME code of IEMA standards. The design pressure on the air side of the cooler shall be 1.25 times the working pressure. A corrosion allowance of 3 mm shall be included for all steel parts.

2.10.4 Air Receivers :

- a) Air receivers shall be designed in accordance with the latest edition of ASME code for Pressure Vessels – Section VIII of BS : 5179. A corrosion allowance of 3 mm shall be provided for shell and dished ends.

Receivers shall be coated on the inside face with antirust medium if it is not hot dip galvanized.

- b) Connection for air inlet and outlet, drain and relief valves shall be flanged type or screwed type. Pressure gauge and pressure switch connection shall be screwed type only.
- c) Accessories such as suitable sized safety valve to relieve full compressor discharge at a set pressure equal to 1.1 times the maximum operating pressure, blow off valve, auto drain tap with isolating and bypass valve, dial type pressure gauge with isolating and drain valve and test connection shall be provided.
- d) Air receivers shall be offered with atleast 50% spare capacity, calculated on the basis of total air requirement for 2 CO operations.

2.10.5 Quality of Air

Compressed air used shall be dry and free of dust particles and fully compatible with the materials used in the pneumatic operating mechanism.

Arrangement for conditioning the compressed air if required shall be provided as and integral part of air compressor system.

If situation warrants, because of the severe ambient conditions, the Contractor may offer centralized compressed air system.

2.10.6 Control and Control Equipment :

- a) The compressor control shall be of automatic start/stop type initiated by pressure switches
- b) Duplicate incoming supply of 415 V, AC shall be provided by the Owner at switchyard bay marshalling box from where the Contractor shall take the feed to the operating mechanism.
- c) All the necessary compressor control equipment shall be housed in a totally enclosed sheet steel cabinet also conforming to requirements of this specification.. Pressure gauges and other indicating devices, control switches shall be mounted on the control cabinet.
- d) A glass window shall be provided for viewing the indicating instrument/gauges. The max. height shall be 2000 mm.

2.10.7 Compressed Air Piping, Valves and Fittings :

- a) The flow capacity of all valves shall be at least 20% greater than the total compressor capacity.
- b) The high pressure pipe and air system shall be such that after one O-0.3 sec-CO operation the breaker shall be capable of performing one CO operation within 3 minutes.
- c) All compressed air piping shall be bright annealed, seamless phosphorous deoxidized Non-Arsenical Copper alloy as per BS : 2874 or stainless steel pipe (C-106 of BS : 2871-1957)
- d) All joints and connections in the piping system shall be brazed or flared as necessary.
- e) All compressed air piping shall be carried out in accordance with BS : 162.
- f) Compressed air piping system shall be complete with Saddle clamps to support the piping system at suitable intervals. Necessary bolts, nuts, pipe fixing clamps etc. shall be included in the scope of Contractor.

2.10.8 Tests :

In accordance with the requirements stipulated under this specification., the compressors and its accessories shall conform to the type tests and shall be subjected to routine tests as per applicable standards.

2.11 INTERPOLE CABLING

2.11.1 All cables to be used by contractor shall be armoured and shall be as per IS – 1554 (1100 Volts Grade). All cables within and between circuit breaker poles shall be supplied by the CB manufacturer.

2.11.2 Only stranded conductor shall be used. Minimum size of the conductor shall be 2.5 sq.mm. (Copper).

2.11.3 The cables shall be with oxygen index Min.-29 and temp. index as 250°C as per relevant standards.

2.12 FITTINGS AND ACCESSORIES

Following is a partial list of some of the major fittings and accessories to be furnished by Contractor in the Central Control Cabinet. Number and exact location of these parts shall be indicated in the bid.

- i) Cable glands (Double compression type), Lugs, Ferrules etc.
- m) Local/remote changeover switch.
- n) Operation counter.
- o) Pneumatic/hydraulic pressure gauges.
- p) Control switches to cut off control power supply.
- q) Fuses as required.
- r) The number of terminals provided shall be adequate enough to wire out all contacts and control circuits plus 24 terminals spare for future use.
- s) Antipumping relay.
- t) Pole discrepancy relay.
- u) D.C. Supervision relays.
- v) Rating and diagram plate in accordance with IEC incorporating year of manufacture.

2.12.1 Additional fittings for pneumatically operated circuit breaker:

- i) Unit compressed air system in accordance with clause 2.11.
- ii) Breaker air receivers.
- iii) Pressure gauge, spring loaded safety valve and pressure switch with adjustable contacts.

- iv) Pressure switch to initiate an alarm if the pressure in the auxiliary reservoir remains below a preset level for longer than it is normally necessary to refill the reservoir.
- v) Stop, non-return and other control valves, pipings and all accessories upto breaker mechanism housing.

2.13 Dead Tank Type Circuit Breaker

In case dead tank type circuit breaker is offered, the bidder shall offer bushing type CTs (whose secondary parameters shall be furnished to successful bidder) on either side of dead tank circuit breaker instead of conventional outdoor CTs.

The enclosure shall be made of either Al/Al alloy or mild steel (suitably hot dip galvanized)

The enclosure shall be designed for the mechanical and thermal loads to which it is subjected in service. The enclosure shall be manufactured and tested according to the pressure vessel codes {i.e., latest edition of the ASME code for pressure vessel-section VIII of BS-5179, IS4379, IS-7311(as applicable) and also shall meet Indian boiler regulations}.

The maximum temperature of enclosure with CB breaker carrying full load current shall not exceed the ambient by more than 20 °C.

The enclosure has to be tested as a routine test at 1.5 times the design pressure for one minute. A bursting pressure test shall be carried out at 5 times the design pressure as type test on the enclosure.

2.14 TESTS:

In accordance with the requirements stipulated as under the circuit breaker along with its operating mechanism should have been successfully type tested as per IEC-56/IEC62271-100.

2.15 Site tests

All routine tests except power frequency voltage dry withstand test on main circuit breaker shall be repeated on the completely assembled breaker at site.

SECTION - 3

PROJECT DETAILS AND GENERAL SPECIFICATIONS

3.0 INTRODUCTION

Kishanganga Hydroelectric project (3x110=330MW) is located in Baramulla district of Jammu and Kashmir state of India. As a part of the project, 220/33 kV Switchyard is being carried out.

3.1 PROJECT INFORMATION

SL. NO	DESCRIPTION	
a)	Customer	NATIONAL HYDRO ELECTRIC POWER CORPORATION LIMITED (NHPC) <u>KISHANGANGA CONSORTIUM:</u> Hindustan Construction Company (HCC) Ltd. HALCROW <u>Subcontractor:</u> Bharat Heavy Electricals Ltd. (BHEL)
b)	Project	220/33kV Switchyard for Kishanganga (3x110MW) HEP
c)	Project locations	Kishanganga Hydroelectric project(3x110=330MW) is located in Baramulla district of Jammu and Kashmir state of India. Refer Project Details from Contract Specification attached herewith.
d)	Nearest Airport	Srinagar is the nearest city, well connected by Air.
e)	Nearest Railway station /Gauge Distance from Railway Station	Jammu is the nearest broad gauge railway head
f)	Road Approach	Refer Project Details from Contract Specification attached herewith.
	Transport Limit	Refer Project Details from Contract Specification attached herewith.

3.2 SITE CONDITIONS

SL. NO	DESCRIPTION	
i.	Altitude	About 1795 m above mean sea level.
ii.	Rainfall (Average annual rainfall)	Refer Project Details from Contract Specification attached herewith.
iii.	AMBIENT AIR TEMPERATURE (a) Max. temp (b) Min. temp	38 deg C -12 deg C
iv.	RELATIVE HUMIDITY (a) Maximum (b) Minimum	94% 62%

--	--	--

Equipment to be supplied against this specification shall be suitable for satisfactory continuous operation under the above tropical conditions.

Seismic Design

The project is situated in a hilly seismic area and falls within Zone V of the seismic zoning Map of India. Value of horizontal component of peak ground acceleration for Maximum Credible Earthquake (MCE) and for Design basis Earthquake (DBE) shall be 0.36g and 0.18g respectively. The forces being caused by earthquake including hydraulic loads, which may occur additionally, shall be taken into account for the computations. Stresses resulting after including these loads shall not exceed permissible stresses.

The Contractor shall design all equipment supplied under this contract to satisfy the seismic criteria. The Contractor shall submit the method of calculation and relevant codes he intends to use for this purpose.

In addition to above, the IS 1893 shall be adopted for seismic design. Hydrodynamic forces due to seismic conditions shall be considered on HM or EM equipment in addition to hydro static loads.

3.2.1 Auxiliary Supply

Auxiliary electrical equipment pertaining to this project shall be suitable for operation at the following supply system.

Normal Voltage	Variation in Voltage	Frequency (Hz)	Phase/Wire	Neutral Connection
415 Volts	± 10%	50 ± 5%	3/4 wire	Grounded neutral
240 Volts	± 10%	50 ± 5%	½	effectively earthed
220 Volts	± 10%	DC	2 wire	Ungrounded, with earth fault detection
48 Volts	± 10%	DC	2 wire	Ungrounded, with earth fault detection

Combined variation of voltage and frequency shall be limited to ± 10%.

3.3 INSPECTION, TESTING AND INSPECTION CERTIFICATE

All equipment being supplied shall conform to type tests and shall be subject to routine tests in accordance with relevant standards.

All tests and inspection of the equipment specified shall be performed to the extent and in the manner as stipulated in the relevant standards and in this specification. All type test/routine tests/acceptance tests as specified shall be conducted in the presence of BHEL/NHPC. Wherever equipment similar to the one being offered has already been type tested in an independent government laboratory or in the presence of representative of State Electricity Board or other reputed public undertakings, Type test reports of the same shall be submitted for approval of BHEL /NHPC.

If these are not found technically acceptable, contractor will have to carry out the type test without any extra cost and/ or delivery implications in presence of BHEL/NHPC.

Where specified by the purchaser, type tests will have to be conducted by the sub-contractor

on the equipment in the scope of supply. Such test shall be witnessed by the customer and BHEL, for which the test charges and delivery implications if any shall be indicated separately by the sub-contractor.

The contractor shall give the Owner/Inspector 3 week's written notice of any material being ready for inspection/testing. Such tests shall be to the Contractor's account except for the expenses' of the Inspector.

The purchaser NHPC/BHEL or their authorized representative shall have at all reasonable times free access to the contractor's works and shall have the power at all reasonable times to inspect the material and workmanship of the works during manufacturing or erection if part of the works is being manufactured or assembled at other premises. Inspection may be made at any stage of manufacture, dispatch or at site at the option of NHPC/BHEL and the equipment if found unsatisfactory due to bad workmanship or quality is liable to be rejected.

When the factory tests have been completed at the subcontractor's works the Owner/Inspector shall issue a certificate to this effect after completion of tests. But if the tests are not witnessed by the Owner/Inspector, the waiver shall be issued by the Owner/Inspector within fifteen (15) days of the receipt of the Contractor's test certificate. Failure of the Owner/Inspector to issue such a waiver shall not prevent the contractor from proceeding with the works. The completion of these tests or the issue of the waiver shall not bind the Owner to accept the equipment should it, on further tests after erection be found not to comply with the Contract. However, in case of waivers, the contractor shall ensure to carry out the testing as per approved quality plans and specification requirements and send two copies of all the test results to the Owner for his review and approval.

In all cases where the Contract provides for tests at the premises or works of the contractor, the contractor, except where otherwise specified shall provide free of charge such items as labor materials, electricity, fuel; water, stores, apparatus and instruments as may be reasonably demanded by Owner/Inspector or his authorized representatives to carry out such tests.

The Inspection by Employer and issue of inspection Certificate thereon shall in no way limit the liabilities and responsibilities of the Contractor in respect of the agreed quality assurance programme forming a part of the contract.

The owner will have the right of having at his own expenses any other test(s) of reasonable nature carried out at contractor premises or at site or in any other place in addition of aforesaid type and routine tests, to satisfy that the material comply with the specification.

The Employer reserves the right for getting any field tests conducted on the completely assembled equipment at site.

3.4 QUALITY ASSURANCE PROGRAMME

The supplier should adopt suitable quality assurance programme to control all necessary activities to ensure that the equipment and / or services under the scope are in accordance with this specification. A quality plan detailing out the specific quality measure and procedures adopted for controlling the quality characteristics to be submitted for BHEL and NHPC approval.

The quality programme is defined by ISO 9001, 1994 Quality systems - Model for quality assurance in design, development, production, installation and servicing.

3.5 DOCUMENTATION

The Contractor shall submit a detailed list of all drawings he proposes to submit for approval/information after the award of the contract. This list shall be revised and extended, as necessary, during the progress of work.

All drawings submitted by the Contractor shall be in sufficient detail to indicate the type, size, arrangement weight of each component, breakdown for packing and shipment, the external connections, fixing arrangements required, the dimensions required for installation and interconnections with other equipment and materials. clearances and spaces required between various portions of equipment and any other information specifically requested.

After the award of the Contract, the Contractor shall submit, (as per the Distribution Schedule enclosed at the end of this section as a Table) copies of design basis reports/concept notes, design calculations, material specifications and detailed drawings as called for in the Contract for the Owner's / Owner's Representative review. The Contractor must satisfy the Owner's / Owner's Representative as to the validity of his design with reference to the requirements of Statutory Codes / Authorities, local regulations and the contract specifications.

All dimensions on drawings shall be in Metric Units, unless otherwise specified. The details in the drawings shall be in English language only.

Drawings submitted by the Contractor will be checked/reviewed by the Owner/Engineer and comments, if any, on the same will be conveyed to the Contractor. It is the responsibility of the Contractor to incorporate correctly all the comments conveyed by the Owner/Engineer on the Contractor's drawings. The drawings which are approved with comments are to be resubmitted to the owner/Engineer for purpose of records. Such drawings will not be checked/reviewed by the Owner/Engineer to verify whether all the comments have been incorporated by the Contractor. If the Contractor is unable to incorporate certain comments in his drawings he shall clearly state in his forwarding letter such non-compliance along with valid reasons and justification.

The Contractor shall not be relieved of his obligations under the Contract if he has not included features in the specification, including but not limited to his Guarantee obligations stated herein, by incorporating the Owner's / Owner's Representative comments.

Any work performed or material ordered by the Contractor prior to receipt of drawings stamped 'Approved with comments as noted', by the Owner/Engineer shall be at the risk of the Contractor. After print of any drawing has been returned 'Approved', the Contractor may release the parts covered by the drawing, for production.

Drawings prepared by the Contractor and approved by the Owner/Engineer shall be considered as a part of the Contract Specification. However, examination and approval of the drawings by the Owner/Engineer shall not relieve the Contractor of his responsibility for engineering, design, workmanship, materials and construction under the Contract.

If, at any time before the completion of the work, changes are made necessitating revision of approved drawings, the Contractor shall make such revisions and proceed in the same routine as for the original approval.

3.5.1 OTHER REQUIREMENTS OF DOCUMENTATION

Upon completion of the installation, the Contractor shall furnish a complete set of drawings

220/33kV Switchyard for Kishanganga (3x110MW) HEP for NHPC Limited

Technical Specification Doc.No. TB 329 316 008 Rev.00

220kV & 33kV Outdoor Circuit Breaker

on reproducible tracing film on which the VENDOR/Contractor shall make in a neat and accurate manner, a complete record of all changes and revisions to, the original design, as installed in the completed work. These drawings shall be submitted to the Owner/Engineer.

AS BUILT DRAWINGS

The Contractor shall prepare and submit to the Owner/Engineer "As- Built drawings" of the Works, showing all Works as executed. The drawings shall be prepared as the Works proceed, and shall be submitted to owner/Engineer for his inspection. The Contractor shall obtain the consent of the Owner as to the drawing size, the referencing system and other pertinent details.

The drawings/documents distribution schedule shall be as indicated below.

The title block of drawings shall contain the following information incorporated in all contract drawings

CUSTOMER	National Hydroelectric Power Corporation Limited (NHPC)				
PROJECT	220/33kV Switchyard for Kishanganga (3x110MW) HEP <u>KISHANGANGA CONSORTIUM:</u> Hindustan Construction Company (HCC) Ltd. HALCROW <u>Subcontractor:</u> Bharat Heavy Electricals Ltd. (BHEL)				
BHEL P.O. No.		PROJ. DOC. No.		REV. No.	
CONTRACTOR	BHARAT HEAVY ELECTRICALS LIMITED 				
<i>VENDOR'S STANDARD TITLE BLOCK</i>					

DOCUMENTS TO BE SUBMITTED ALONGWITH OFFER

- 1) Drawings
- 2) Guaranteed Technical Particulars
- 3) Type Test Reports
- 4) Manufacturing Quality Plan

DOCUMENTATION SCHEDULE AT CONTRACT STAGE

A	For Approval
7 (6+1)	Copies of GA drawings with projects details, dimension, equipment weight, fixing details, tolerances and terminal details etc.
7 (6+1)	Copies of type test reports
7 (6+1)	Copies of shipping list detailing the description & quantities of all items being dispatched separately, with shipping weights, number of cases and dimensions.
7 (6+1)	Copies of manufacturing and field quality plan.
B	After Approval and For Information/Distribution.
11 (10+1)	Copies of All drawings plus 2 Set Reproducibles.
11 (10+1)	Bound sets containing all 'as built' drawings/manuals, type and routine test reports etc. along with sub-vendor's test reports for all bought out assemblies/components/parts including Internal wiring diagrams and exploded diagrams of assemblies/ parts, shall be furnished plus 2 Set IR
11(10+1)	Copies of Installation, Operation & Maintenance manual.
11(10+1)	Sets of Spare parts catalogue.
5	Set of Computer CD-ROMs containing all 'as-built' drawings/documents.

All the technical documents and drawings required to be furnished under this contract as per specification shall be prepared in internationally accepted software of latest version used for preparation of documents and drawings.

All the drawings and documents shall be submitted in presentable folders properly bound and catalogued for easy retrieval / reference. Drawings shall be submitted in A0 / A2 /A3 and all documentation in A4 size. All drawings shall be digitally printed/ plotted. Ammonia print/ blue print shall not be accepted.

Time schedule of drawings/documents required at contract stage shall be furnished by the supplier.

Material shall not be dispatched without the approval of test certificates by purchasers.

3.6 MATERIALS AND WORKMANSHIP

3.6.1. GENERAL REQUIREMENTS

Where the specification does not contain characteristics with reference to workmanship, equipment materials and component of the covered Equipment, it is understood that the same must be new, of highest grade of the best quality of their kind, conforming to the best engineering practice and suitable for the purpose for which they are intended.

The equipment must be new, of highest grade, the best quality of their kind, to best engineering practice, latest state of art and in accordance with purpose for which they are intended and to ensure satisfactory performance throughout the service life.

Incase where the equipment material or components are indicated in the specification as “similar” to any special standard, the employer shall decide upon the question of similarity. When required by the specification or required by the employer the supplier shall submit, for approval, all the information concerning the material or components supplied, installed or used. Without such approval shall run the risk of subsequent rejection, it being understood that the cost as well as the time delay associated with the rejection shall be borne by the Supplier.

The design of the work shall be such that Installation, future expansions, replacement and general maintenance may be undertaken with a minimum of time and expenses. Each component shall be designed to be consistent with its duty and suitable factors of safety, subject to mutual agreements and shall be used throughout the design. All Joints and fastenings shall be devised, constructed and documented so that the component part shall be accurately positioned and retained to fulfill their required function. In general, screw threads shall be standard metric threads. The use of other thread forms will only be permitted when prior approval has been obtained from the Employer.

Whenever possible, all similar part of the works shall be made to gauge and shall also be made interchangeable with similar parts. All spare parts shall be interchangeable with, and shall be made of the same material and workmanship as the corresponding parts of the equipment supplied under specification. Where feasible, common component units shall be employed in different pieces of the equipment in order to minimize spare parts stocking requirements. All equipment of the same type and rating shall be physically and electrically interchangeable.

All material and equipment shall be installed in strict accordance with the manufacturer’s

recommendation(s). Only first-class work in accordance with the best modern practice will be accepted. Installation shall be considered as being the erection of equipment at its permanent location. This, unless otherwise specified, shall include unpacking, cleaning and lifting into position, grouping, leveling, aligning, coupling of or bolting down to previously installed equipment bases/ foundation, performing the alignment check and final adjusting prior to initial operation, testing and commissioning in accordance with the manufacturer's tolerances and instruction and the specification. All factory assembled rotating machinery shall be checked for alignment and adjustments made as necessary to re-establish the manufacturer's limits suitable guards shall be provided for the protection of personnel on all exposed rotating and/or moving machine parts and shall be designed for easy installation and removal for maintenance purpose. The spare equipment(s) shall be installed at designated location and tested for healthiness.

The Supplier shall apply oil and grease of the proper specification to suit the machinery, as is necessary for the installation of the equipment Lubricants used for installation purpose shall be drained out and the system flushed through where necessary for applying the lubricant required for operation. The Supplier shall apply all operational lubricants to the equipment installed by him.

All oil, grease and other consumables used in the Works/Equipment shall be purchased in India unless the Supplier has any special requirement for the specific application of a type of oil or grease not available in India. If such is the case he shall declare in the proposal, where such oil or grease is available. He shall help Employer in establishing equivalent India make and Indian supplier. The same shall be applicable to other consumables too.

A cast iron or welded steel base plate shall be provided for all rotating equipments which are to be installed on a concrete base unless otherwise agreed to by the Employer. Each base plate shall support the units and its drive assembly, shall be of design with pads for anchoring the units and shall have a raised up all around and shall have threaded in air connections, If so required.

All components exposed to rain shall be designed with sloped upper surface to avoid water pools.

3.7 CLAMPS AND CONNECTORS INCLUDING TERMINAL CONNECTORS

All power clamps and connectors shall conform to IS:5561 & NEMA CCI and shall be made of materials listed below:

a	For connecting ACSR	Aluminium alloy casting conforming to designation A6 of IS:617 and shall be tested for all test as per IS:617
b	For connecting equipment terminals made of copper with ACSR conductors	Bimetallic connectors made from Aluminium alloy casting conforming to designation A6 of IS:617 with 2mm thick liner and shall be tested as per IS:617
c	For connecting GI shield wire	Galvanised mild steel
d	I) Bolts, nuts & plain washer galvanised II) Spring washers for items 'a' to 'c'	i) Electro galvanisation for sizes below M12, for others hot dip Galvanised ii) Electro Galvanised mild steel suitable for at least service condition-3 as per IS: 1573

Each equipment shall be supplied with the necessary terminals and connectors, as required by the ultimate design for the particular installation. The conductor termination of equipment shall be suitable for Twin/ single Zebra/ Moose ACSR Conductor with 250 mm Sub-Conductor spacing. The requirement regarding external RIV as specified for any equipment shall include its terminal fittings and the equipment shall be factory tested with the connectors in position

Where copper to aluminium connections are required, bi-metallic clamps shall be used, which shall be properly designed to ensure that any deterioration of the connection is kept to a minimum and restricted to parts which are not current carrying or subjected to stress. The design details of the joint shall be furnished to the employer by the supplier.

Low voltage connectors, grounding connectors and accessories for grounding all equipment as specified in each particular case, are also included in the scope of work.

No current carrying part of any clamp shall be less than 12 mm thick. All ferrous parts shall be hot dip galvanized. Copper alloy liner of minimum 2 mm thickness shall be cast integral with aluminium body for Bi-metallic clamps.

Lateral load deflection test shall be carried out as an acceptance test. The test procedure and accepted norms shall be mutually discussed and agreed to.

All casting shall be free from blow holes, surface blisters, cracks and cavities. All sharp edges and corners shall be blurred and rounded off.

Clamp shall be designed to carry the same current as the conductor and the temperature rise shall be equal or less than that of the conductor at the specified with respect to the specified reference ambient temperature shall also be indelibly marked on each component of the clamp/connector, except on the hardware.

All current carrying parts shall be designed and manufactured to have minimum contact resistance.

Clamps and connectors shall be designed to be corona controlled. RIV level for 220 kV/ 132 kV system shall not be more than 1000 micro volts respectively at the specified test voltage as per IS/NEMA

3.7.1. TESTS

Clamps and connectors shall confirm to type tests and shall be subjected to routine tests as per IS:5561

3.7.2. HIGH VOLTAGE TERMINAL

The high voltage terminals shall be preferably made of aluminium or aluminium alloy. If copper terminals are used, they shall be tin-plated. The conductor termination of equipment shall be either expansion, sliding or rigid type suitable for ACSR Conductor./Aluminium tube.

3.7.3. GROUND TERMINAL EARTHING

Positive earthing of the cabinet shall be ensured by providing two separate earthing pads. The earth wire shall be terminated on to the earthing pad and secured by the use of star of self etching washer. Earthing of hinged door shall be done by using a separate earth wire.

3.8 NAME PLATES, RATING PLATES AND LABELS

- a) Each main and auxiliary item of equipment is to have permanently attached to it in a conspicuous position a rating plate of non-corrosive material upon which is to be engraved the following:

- i) Manufacturer's name
- ii) Type number
- iii) Serial number
- iv) Rated voltage
- v) Rated impulse withstand voltage
- vi) Rated power frequency withstand voltage
- vii) Rated frequency
- viii) Rated current
- ix) Rated short circuit breaking current
- x) Rated short time current (rms) & duration.

together with details of the loading conditions under which the item of substation in question has been designed to operate and such diagram plates as may be required by the Employer. The rating plate shall confirm to IEC requirement.

- b) All such name plates, instruction plates, rating plates etc. shall be in bilingual with Hindi inscription first followed by English. Alternatively, two separate plates one with Hindi & the other with English inscription may be provided.

3.9 PROVISIONS FOR EXPOSURE TO HOT AND HUMID CLIMATE

Outdoor and indoor equipment supplied shall be suitable for service and storage under tropical conditions of high & low temperature, high humidity, heavy rainfall and environment favourable to the growth of fungi and mild dew.

3.9.1. SPACE HEATERS

The heater shall be suitable for continuous operation at 240 V AC supply voltage and shall be provided with on – off switch and fuse.

One or more adequately rated, thermostatically connected heaters shall be supplied to prevent condensation in any compartment. The heater shall be installed in the lower portion of the compartment and electrical connections shall be made from below the heater to minimize deterioration of supply wire insulation. The heaters shall be suitable to maintain the compartment temperature to prevent condensation.

The heaters shall be suitably designed to prevent any contact between the heater wire and air and shall consist of coiled resistance wire centred in metal sheath and completely encased in a highly compacted powder of Magnesium Oxide or other material to prevent any contact between the wires. Alternatively, they shall consist of a resistance wire mounted into a tubular ceramic body built in to an envelop of stainless steel or the resistance wire is wound on a tubular ceramic body and embedded in vitreous glaze. The surface temperature of the heaters shall be restricted to a value, which will not shorten the life of the heater sheaths or that of insulated wire or other component in the compartments.

3.9.2. FUNGISTATIC VARNISH

Besides the space heaters, special moisture and fungus resistant varnish shall be applied to parts which may be subjected or predisposed to the formation of fungi due to the presence or deposit of nutrient substances. The varnish shall not be applied to any surface of part where the treatment will interfere with the operation or performance of the equipment. Such surfaces

or parts shaft be protected against the application of the varnish.

3.9.3. VENTILATION OPENING

In order to ensure adequate ventilation, components shall have ventilation openings provided with fine wire mesh of brass or galvanized steel to prevent the entry of insects and to reduce to a minimum the entry of dirt and dust. Outdoor compartment openings shall be provided with shutter type blinds.

3.9.4. DEGREE OF PROTECTION

The enclosures of the control cabinets, junction boxes and marshalling boxes to be installed shall provide degree of protection as detailed here under:

- a) Installed outdoor: IP-65
- b) Installed Indoor in air conditioned area: IP-40 or higher
- c) Installed in covered area: IP-52
- d) Installed indoor in non-air conditioned area where possibility of entry of water is limited: IP-41
- e) For LT Switchgear (AC & DC Distribution Boards): IP-52

The degree of protection shall be in accordance with IS: 13947(Part-I) or IEC-947 (Part-I). Type test report for degree of protection test, on each type of the box shall be submitted for approval.

3.9.5. TROPICALISATION

All equipment shall be suitable for installation in a tropical monsoon area having hot, humid climate and dry and dusty seasons with ambient conditions as specified. All control wiring, equipment and accessories shall be protected against fungus growth, condensation, vermin and other harmful effects due to a tropical environment.

3.10 SURFACE TREATMENT, PAINTING AND FINISHING OF METAL SURFACES

3.10.1. GENERAL

All metal surfaces shall be subjected to treatment for anti-corrosion protection. All ferrous surfaces for external use shall be hot-dip galvanized after fabrication. High tensile steel nuts and bolts and spring washers shall be electro-galvanized to service condition. All steel conductors including those used for earthing/grounding (above ground level shall also be galvanized according to IS:2629.

3.10.2. HOT DIP GALVANIZING

The minimum weight of the zinc coating shall be 610g/sq.m and minimum thickness of coating shall be 85 microns for all items thicker than 6mm. For Items lower than 6mm thickness requirement of coating thickness shall be as per relevant ASTM.

The galvanized surfaces shall consist of a continuous and uniform thick coating of zinc, firmly adhering to the surface of steel. The finished surfaces shall be clean and smooth and shall be free from defects like discoloured patches, bare spots, unevenness of coating, plate which is loosely attached to the steel globules, spiky deposits, blistered surface, flaking or peeling off, etc. The presence of any of these defects noticed on visual or microscopic inspection shall render the material liable to rejection.

After galvanizing, no drilling or welding shall be performed on the galvanized parts of the equipment excepting that nuts may be threaded after galvanizing. Sodium dichromate treatment shall be provided to avoid formation of white rust after hot dip galvanization.

The galvanized steel shall be subjected to six one minute dips in copper sulphate solution as per IS-2633.

Sharp edges with radii less than 2.5mm shall be able to withstand four immersions of the standard preece test. All other coating shall withstand six immersions. The following galvanizing tests should essentially be performed as per relevant Indian Standards.

- Coating
- Uniformity of zinc
- Adhesion test
- Mass of zinc

Galvanized material must be transported properly to ensure that galvanized surfaces are not damaged during transit Application of zinc rich paint at site shall not be allowed.

3.10.3. PAINTING

All sheet steel work shall be degreased, pickled, phosphated in accordance with the IS-6005 'code of practice for phosphating Iron and sheet'. All surfaces which will not be easily accessible after shop assembly, shall before hand to be treated and protected for the life of the equipment The surface which are to be finish painted after installation, shall be shop painted with atleast two coats of primer. Oil, grease, dirt and swart shall be thoroughly removed by emulsion cleaning. Rust and scale shall be removed by pickling with dilute acid followed by washing with running water, rinsing with slightly alkaline hot water and drying.

After phosphating, thorough rinsing shall be carried out with clean water followed by final rinsing with dilute dichromate solution and oven drying. The phosphate coating shall be sealed with application of two coats or ready mixed, stoving type zinc chromate primer, the first coat may be flash dried, while the second coat shall be stoved.

After application of the primer, two coats of finishing synthetic enamel paint shall be applied, each coat followed by stoving. The second finishing coat shall be applied after inspection of first coat of painting.

The exterior colour of the paint shall be as per shade No.:631 of IS-5 and inside shall be glossy white. Each coat of primer and finishing paint shall be of slightly different shade to enable inspection of the painting. A small quantity of finishing paint shall be supplied for minor touching up required at site after installation of the equipments.

In case the bidder proposes to follow his own standard surface finish and protection procedures or any other established painting procedures, like electrostatic painting etc. the procedure shall be submitted along with the bids for employer's review & approval.

3.11 CASTING

All castings shall be true to pattern, free from defects and of uniform quality and condition. The surface of castings, which do not undergo machining, shall be free from foundry irregularities. The casting shall be tested for NDT, chemical, mechanical and metallographical tests. This shall be specified in quality plan for the specific equipment. Iron casting material shall be in accordance with ASTM A 126 class B. Steel casting shall be manufactured in accordance with ASTM A 27 and shall be subject to appropriate tests and inspection.

3.12 FORGINGS

If requested by purchaser, forging shall be tested by magnetic particle, dye penetration,

radiographic, ultrasonic or any combination of methods, which may suit material type and forging design. The testing is to be carried out according to appropriate ASTM standards. The forging shall be tested for mechanical and metallographical tests as per ASTM.

3.13 FABRICATED COMPONENTS

All components machined or fabricated from plate, sheet or bar stock shall meet the material requirements of ASTM. Structural steel, rolled shapes, bars etc. shall comply with the latest ASTM for A36.

All or a representative number of such components shall be subjected to one or more of the tests: visual, dye penetration, magnetic particle (transverse and longitudinal), ultrasonic or radiograph. These tests shall be in accordance with the ASTM. The acceptance shall be as per ASTM Specifications.

3.14 CONTROL CABINETS, JUNCTION BOXES, TERMINALS BOXES AND MARSHALLING BOXES FOR OUTDOOR EQUIPMENTS

Unless otherwise specifically called for or described in these Contract documents all electrical appliances shall conform to the applicable IEC Publications.

The cubicles and enclosures shall be of protection class IP 40 or higher according to their location. For outside installation and area which are humid, corrosive, and prone to dripping and/ or spray of water, the protection class of cubicles shall be IP 65. Cubicles housing electronic cards/modules such as of unit control boards/local control boards, digital governors, static excitation equipment shall be of protection class of IP 5X.

Cables shall have at least 1000 V PVC insulation except for 220V DC and tele-metering or communication system equipment for which 650V and 300 V ratings respectively are acceptable.

For current and potential transformer secondary circuits the minimum cross section of the conductors shall not be less than 4.0 mm².

Wiring shall terminate at terminal blocks at one side only. Where tap connections are required, they shall be made on terminal blocks. Wiring shall be neatly arranged and laid in wire ways accessible from the front door. The wire ways shall not be filled more than 70 %.

Each cubical shall be provided with an earthing bar (PE) of sufficient cross section carrying any possible fault current without undue heating. All metallic parts of the cubicle not forming part of the live circuits, all instrument transformer terminals to be earthed and other earthing terminals as well as all cable screens and PE-wires shall be connected to the earthing bar.

All internal equipment and wiring shall be neatly and clearly marked as indicated on the schematic and wiring diagrams. Internal wiring and cables shall be marked with sleeve type engraved marking. Marking system and marking material shall be subject to approval by Employer. Identification of the respective conductors shall be in accordance with the requirements of IEC publication 60204. In cable, having five conductors or more the individual conductors shall be numbered throughout the entire length. In cables having less than five conductors colour coding in accordance with IEC Recommendations 60204 shall be used.

Cubicles and control panel enclosures shall be of cold rolled sheet steel with minimum thickness for load bearing members as 2.5mm and non load bearing as 2 mm, of rigid, self-

supporting construction and supplied with channel bases made to ensure no bulging takes place.

Cubicles shall be fitted with close fitting, gasketed, hinged, lift-off doors capable of being opened through 180 deg. The doors shall be provided with integral lock and master key.

Cubicles and panels shall be vermin proof. Removable gland plates shall be supplied and located to provide adequate working clearance for the termination of cables. Under no circumstances shall the floor/roof plate be used as a gland plate. The cables and wiring shall enter from bottom or top as approved or directed by the Engineer.

The cubicles and panels shall be adequately ventilated, if required, by vents or louvers, and shall be so placed as not to detract from the appearance. All ventilating openings shall be provided with corrosion-resistant metal screens or a suitable filter to prevent entrance of insects or vermin. Space heating elements with thermostatic control shall be included in each panel.

Where cubicles are split between panels for shipping, terminal blocks shall be provided on each side of the split with all necessary cable extensions across the splits. These cable extensions shall be confined within the panels with suitable internal cable ducts.

Unless stated otherwise, all cubicles and panels shall be provided with a ground bus with 40mm copper bar extending through out the length. Each end of this bus shall be drilled and provided with lugs for connecting ground cables ranging from 70 to 120mm².

The standard phase arrangement when facing the front of the motor control centres and switchboard shall be RYB from left to right, from top to bottom and front to back. All instruments, devices, buses and other equipments involving 3 phase circuits shall be arranged and connected in accordance with the standard phase arrangement, where possible. Electrical clearances shall conform to applicable standards and shall not require cutting away of adjacent framework.

All instruments, control knobs and indicating lamps shall be flush mounted on the panels. Relays and other devices sensitive to vibration shall not be installed on doors or hinged panels, and no equipment shall be installed on rear access doors.

The instrument and control wiring, including all electrical interlocks and all interconnecting wiring between sections, shall be completely installed and connected to terminal blocks by the manufacturer.

The arrangement of control and protection devices on the panels and the exterior finish of the panels shall be subject to the approval of the Engineer. The interior of all cubicles and panels shall have a mat white finish unless specified otherwise.

Switched interior light and socket outlets shall be provided for all cubicles and control panels.

All cubicles and control panels shall be provided with lamacoid nameplates, identifying the purpose of the panel and all of its components.

Control switches, indicating lamps and instruments

Measuring converters

The converters shall be suitable for direct connection to the secondary circuits of the potential and current transformers used, or other sensors, each as they apply. The converters shall be

static type, having all accessories to provide an output signal of 4-20 mA, filtered DC.

For the measuring converters the following minimum requirements shall be fulfilled:

Current transducers shall be single-phase, of accuracy class 0.5 or better.

Voltage transducers shall be single-phase of accuracy class 0.5 or better.

W and VAr transducers shall be two elements, three-phase. Accuracy class of the transducers shall be 0.5 or better.

Measuring transformers

Potential transformer secondary windings shall be rated $110/\sqrt{3}$ V

Current transformer secondary windings shall have a rated current of 1A/2.5A /5A.

3.14.1. EARTHING:

Positive earthing of the cabinet shall be ensured by providing two separate earthing pads. The earth wire shall be terminated on to the earthing pad and secured by the use of star of self etching washer. Earthing of hinged door shall be done by using a separate earth wire.

3.14.2. TESTS

a) The marshalling kiosks shall be subject to routine tests as per IS:5039

b) The following routine tests shall also be conducted:

- I) Check for wiring
- II) Visual and dimension check

Marshalling kiosks shall be provided with danger plate and a diagram showing the numbering /connection / ferruling by pasting the same on the inside of the door.

3.15 BUSHINGS, HOLLOW COLUMN INSULATORS, SUPPORT INSULATORS:

Bushings shall be manufactured and tested in accordance with IS: 2099 & IEC: 137 while hollow column insulators shall be manufactured and tested in accordance with IEC 233/IS 5621. The support insulators shall be manufactured and tested as per IS 2544/IEC 168 and IEC 273. The insulators shall also conform to IEC 815 as applicable.

Support insulators, bushings and hollow column insulators shall be manufactured from high quality porcelain. Porcelain used shall be homogeneous, free from laminations, cavities and other flaws or imperfections that might affect the mechanical or dielectric quality and shall be thoroughly vitrified tough and impervious to moisture.

Glazing of the porcelain shall be uniform brown in colour, free from blisters, burrs and similar other defects.

Supports insulators/bushings/hollow column insulators shall be designed to have ample insulation, mechanical strength and rigidity for the conditions under which they will be used.

When operating at normal rated voltage there shall be no electric discharge between the conductors and bushing which would cause corrosion or injury to conductors, insulators or supports by the formation of substances produced by chemical action. No radio interference shall be caused by the insulators/bushings when operating at the normal rated voltage.

Bushing porcelain shall be robust and capable of withstanding the internal pressures likely to occur in service. The design and location of clamps and the shape and the strength of the

porcelain flange securing the bushing to the tank shall be such that there is no risk of fracture. All portions of the assembled porcelain enclosures and supports other than gaskets, which may in any way be exposed to the atmosphere shall be composed of completely non hygroscopic material such as metal or glazed porcelain.

All iron parts shall be hot dip galvanized and all joints shall be air tight. Surface of joints shall be trued up porcelain parts by grinding and metal parts by machining. Insulator/bushing design shall be such as to ensure a uniform compressive pressure on the joints.

3.16 SEISMIC WITHSTAND TEST PROCEDURE

The seismic withstand test on complete equipment shall be carried out along with the supporting structure. The Supplier shall arrange to transport the structure from the structure supplier's works/ project site or alternatively arrange the structure as per approved drawings for the purpose of seismic withstand test only.

The seismic level specified shall be applied at the base of the structure. The accelerometers shall be provided at the terminal pads of the equipment and any other point as agreed by BHEL / customer. The seismic test shall be carried out in all possible combinations of the equipment. The seismic test procedure shall be furnished for approval of BHEL / customer.

3.17 FIRST FILL OF CONSUMABLES, OIL AND LUBRICANTS

All the first fill of consumables such as oils, lubricants, filling compounds, touch up paints, soldering / brazing material for all copper piping of circuit breakers and essential chemicals etc which will be required to put the equipment covered under the scope of the specifications, into successful operations, shall be furnished by the contractor unless specifically excluded under the exclusions in these specifications and documents.

3.18 PACKING AND SHIPPING

All the equipment shall be suitably protected, coated, covered or boxed and crated to prevent damage or deterioration during transit, handling and storage at site till the time of erection. While packing all the materials, the limitation from the point of view of availability of Railway wagon sizes in India should be taken account.

The Contractor shall mark all containers with the implementing document number pertinent to the shipment. Each shipping container shall also be clearly marked on at least two sides as follows:

- ◆ Consignee : to be furnished at a later date
- Contract No. :
- Country of Origin :
- Port of entry :
- Item number (if applicable) :
- Package number, in sequence :
- and quantity per package :
- Description of Works :
- Net and gross weight, volume :

The Contractor shall be responsible for any loss or damage during transportation, handling and storage due to Improper packing. Employer takes no responsibility of the wagons.

220/33kV Switchyard for Kishanganga (3x110MW) HEP for NHPC Limited

Technical Specification Doc.No. TB 329 316 008 Rev.00

220kV & 33kV Outdoor Circuit Breaker

--- X X ---

The power house and switchyard would also have illumination system, grounding system, Public address system and PLCC system.

3.0 SALIENT FEATURES OF THE PROJECT

Based upon preliminary designs, the salient features of the project are as under:

Location	
State	Jammu & Kashmir
District	Baramulla
River	Kishanganga
Dam site	Gurez valley-100m u/s of Malik Kadal bridge
Latitude	34° 39' 00"
Longitude	74° 45' 08"
Powerhouse site	Near village Kralpora Tehsil Bandipura
Latitude	34° 28' 17"
Longitude	74° 38' 28"
Hydrology	
Catchment area	1815 Km ²
Maximum observed flood	740 cumec
Probable max. flood	2000 cumec
Average Annual run off	1342.5 Mcum
Annual rainfall	676 mm
Annual snowfall (in terms of water equivalent)	1206 mm
Reservoir	
Full Reservoir Level	EI. 2390.00 m
Maximum Reservoir level	EI. 2390.00 m
Minimum Draw Down Level	EI. 2384.50 m
Gross storage up to FRL	18.35 Mcum
Dead storage capacity	10.80 Mcum
Live storage capacity	7.55 Mcum
Diversion tunnel	
Number	1
Size, Shape	6.5m diameter, Horse shoe
Length	560 m
Diversion capacity	286 cumec



Dam

Type	Concrete face rock fill dam
Maximum height above Deepest river bed	37 m
Elevation of top of dam	El. 2395.00m

Spillway

Design flood	2000 cumecs
Type	Chute spillway
Crest Elevation	El 2370 m
No. & size of spillway gates	3 Nos., 7.0m (w) x 9.5m (h)
Maximum discharge over Spillway per meter width	95.23 cumec / m
Energy dissipation	Flip bucket
Crest level of spilling channel	El 2389.00 m
Width of spilling channel	12.5 m

Intake

Invert level	El 2378.80 m
No. & size of opening	2 nos. , 4.25m(w) x 2.5m (h)

Head Race Tunnel

Number	1
Size & Shape	5.4m HS (DBM) / 5.2 Circular (TBM)
Length	23.5 km .
Design discharge	58.4 cumec

Construction Adit

No. & length	Inlet Adit	200 m	}
	Adit-1	500m	
	Surge shaft end adit	300 m	

Surge shaft

Diameter	15 m
Height	112 m
Type	Restricted orifice
Maximum surge level	El. 2415.00 m
Minimum surge level	El. 2325.00 m



Pressure shaft

No. & Type One, stepped, circular, Steel lined
 Diameter 4.0m diameter, trifurcating into three
 2.10 m diameter penstocks

Powerhouse complex

Type Underground
 Installed capacity 330 MW
 No. of units 3
 Powerhouse cavern 113 m(l) x 21.3m (w) x 46.5m (h)
 Transformers hall cavern 75 m (l) x 15m (w) x 15.2m (h)
 Service bay level El 1735.80m
 C/L of machines El 1723.50m
 Elevation of bottom of draft tube El 1714.00m
 Type of turbine Pelton wheel
 Design Max. gross head 665m
 Rated net head 640m

Ventilation cum cable tunnel

Size, shape 4m x 4m, D-shape
 Length 580 m

Access tunnel

Size, shape 8.0m (w) x 6.5 m (h) D-shape
 Length 686m

Adit to powerhouse crown

Size, shape 6m x 6m, D-shape
 Length 184 m

Tail Race System

Tunnel D-shape
 Length 700 m (approx)
 Diameter 5.0 m
 Open channel portion
 Length 100 m

Switchyard

Size & location 200m x 130m near Kralpora village

Power Generation

Installed capacity 330 MW

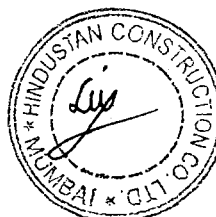

Peaking capacity during lean period	330 MW
Annual Design Energy generation	1350 MU

4.0 ACCESS TO AND WITH IN THE PROJECT AREA.

4.1 General

The Kishanganga Hydro electric project is located in the great Himalayan ranges close to the LOC. The dam site of the project is situated in Gurez valley and power house site is at Bandipora in Kashmir valley of J&K state. Srinagar is the nearest city, well connected by Air. Approximate distances of Project from different important towns are as below.

	Dam site	Power House Site
From Delhi	1025 km	955 km
From Jammu	440 km	370 km
From Srinagar	140 km	70 km

4.2 Jammu – Srinagar Road

- (1) The principal access road to the Site is the approximately 300 km long National highway NH-1A connecting Jammu to Srinagar. This road is under the administrative control of BRO (Border Roads Organisation) which is responsible for the maintenance of this road.

Along certain stretches of NH-1A, the slopes above the road become unstable when saturated during the monsoon time and the road gets blocked by the resulting landslides and rock falls. Such blockages will, in general, be cleared by BRO as soon as reasonably possible.

- (2) NH1A between Banihal and Quazigund passes through a road tunnel known as Jawahar Tunnel and has height and width restrictions. Cross-section of tunnel is enclosed as plate-4.1
(The Contractor has to keep in view, of above mentioned critical dimensions of Jawahar Tunnel for transportation of his Construction Equipment and Electromechanical & Hydromechanical Plant & Machinery).

4.3 Srinagar – Bandipora road

- (1) First 8 km stretch of this road (Between Srinagar and Sheltang) is covered under National Highway 1 A.
- (2) The next 50 Kms(i.e KM 8 to 58) between Shetang and Bandipora is also a National highway with double lane specification and plain ruling gradient. While in general the formation width of this road is between 7



to 10 m , at certain locations the formation width available is restricted to 4m only.

(3) Bridge Details

- At KM 25, Sumbal RCC bridge (168 m length) with loading capacity 70 R.
- At KM 27, Nadinara steel bridge(18.5 m length) with loading capacity 18 R. However, this nallah portion can also be crossed by diversion road through Nandinara Village. Any temporary additional measures for diversion road shall be planned and executed by the Contractor.
- At KM 41.9, Ajass RCC bridge (14 m length) with loading capacity 70 R.
- At KM 53.75, RCC bridge (10 m length) with loading capacity 70R.
- At KM 53.80, RCC bridge (5 m length) with loading capacity 70R.
- At KM 54.70, Steel Bridge on papchan nallah (A) with length 29 m and loading capacity 18 R. At KM 54.80, Steel bridge on Papchan nallah(B) with length 29 m and loading capacity 18 R. However, these nallah portions can also be crossed during the lean season through bed crossing. Any temporary additional measures for crossing of these nallahs shall be planned and executed by the Contractor.

4.4 Bandipora – Surge shaft top stretch of road

1. The total length of this reach of the road is 21 km. The road is class 9H with ruling gradient and with formation width of 5.95 m.
2. At Km .3 of this road there is a steel bridge on Madumati Nallah with length 75.73 m and loading capacity 24 R. At the same location, a RCC Bridge with length 55 m and loading capacity 70 R is under construction. by BRO. However, the nallah can also be crossed during the lean season through bed crossing. Any temporary additional measures for crossing of this nallah shall be planned and executed by the Contractor.

4.5 Bandipora – Dam site road

1. Bandipora- Dam site road beyond surge shaft top is 51 km (KM 21 to 72) long. Between KM 21 to 39, road is class 9 H with ruling gradient



with formation width of 5.95 m. Between KM 39 to 60, road is class 9 (Snow bound specification) with ruling gradient with formation width 7.45 m. Between KM 60 to 72 and beyond, road is again class 9 H with ruling gradient with formation width 5.95 m.

2. This road is maintained by Border Roads Organisation (BRO). This road remains open only for approximately 5-6 months i.e May/ June to November in a year and for rest of the period of the year remains blocked due to heavy snow fall as it passes through Razdan pass at an altitude of 3600 m.
3. Bandipora - Gurez road is a strategic road. Contractor shall plan his movements in coordination with concerned authorities. Owner shall provide assistance in such co-ordination. Up-gradation and maintenance of Bandipora - gurez road if required by the Contractor for transportation of his Construction Equipment shall be done by the Contractor with specific approval from BRO. Bridge Details
 - o At KM 55.0, SSRBB type bridge with length 21.34 m and loading capacity 24 R.
 - o At KM 59.5, SSRBB type bridge with length 18.29 m and loading capacity 24R.
 - o At KM 66.0, HAMILTON type bridge with length 18.29 m and loading capacity 18 R.

However the above nallahs can also be crossed during the lean season through bed crossing. Any temporary-additional measures for crossing of these nallah shall be planed and executed by the Contractor.

- o At KM 66.95, TSRBB type bridge with length 44.12 m and loading capacity 18R (Kanjalwan Bridge on Kishanganga River)
- o At KM 71.80, TSRBB type bridge with length 42.87 m and loading capacity 24 R (Malik Bridge on Kishanganga River)
- o At KM 72.2, HAMILTON type bridge with length 12.19 m and loading capacity 18R on Dudkhatu nallah. However, the nallah also be crossed during the lean season through bed crossing.

Any temporary additional measure for crossing of the nallah shall be planned and executed by the Contractor.

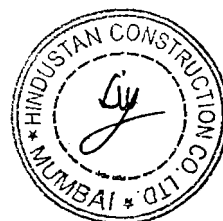

4.6 Access to Gurez valley during winter:

Helicopter access (between Bandipora-Gurez or Srinagar – Gurez) is must during winter to continue at least the underground works pertaining to HRT at inlet Adit and Adit 1 during the period November to May. The Contractor shall be required to tie up this arrangement with Indian Army / Indian Air Force authorities. Owner shall provide any assistance for coordination with concerned authorities.

4.7 Access roads to permanent works

4.7.1 Access roads with in Power house complex

Following access roads shall be required in power house complex.

Access road to main access tunnel

Access road to switch yard/ ventilation tunnel

Access road to tail race outlet

Access road to various adits of pressure shaft

Access road to Surge shaft bottom and for TBM tunneling

Access road to surge shaft top

The land for these roads shall be made available by Owner free cost. The detailed planning, engineering, construction and maintenance shall be done by the Contractor.

4.7.2 Access roads for HRT adit 1 and with in Dam complex

The HRT Adit 1 portal is situated on Bandipora – Gurez road near Kanzalwan. Various access and temporary haul roads for access to different locations in dam complex shall be planned, constructed and maintained by the Contractor.

4.7.3 Land for Permanent Works

The land for the Permanent Works shall be handed over in a phased manner as per the following schedule subject to Contractor complying with the requirement under GCC Article 46.1:

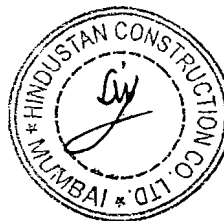
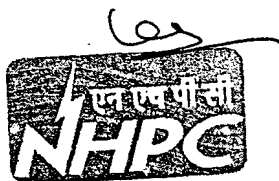

Sl. No.	Allocation of Land for	Time from the date of Order to Commence
1	Dam Area including Intake Adit and Diversion Tunnel Area.	4 Months
2	Adit-I Area	4 Months
3	Surge Shaft Area and T.B.M Adit Area	4 Months
4	Power House Area and Construction Adits to Pressure Shaft.	9 Months
5	T.R.T and Switchyard Area.	9 Months

For the purpose of land acquisition the layout of the Project structures, should normally be as per the Project Profile to the extent possible. However, in case of change in Project Layout due to unavoidable circumstances the bidder shall note that the land acquisition for any new location would take about 1 year.

5.0 Local facilities and services in the project area

5.1 Availability of land for Contractor's infrastructure for main works

The Contractor has to make his own arrangement to develop infrastructure for all their men and material required during the construction period. The necessary residential and labour camps including other facilities like water supply, sanitation etc. are to be developed by the Contractor on his own.

Private land is available for Contractor's use at Badwan; Wampore, Dawar and Kanjalwan for dam site and at Bandipore and near by villages for powerhouse site. The Contractor will be responsible for arranging land for his infrastructure and other facilities in these areas.

All the camps, facility areas, main works area etc. are required to be fenced and protected by the Contractor on his own.

5.2 Identified source of water supply for Contractor's use

The main source of water supply for construction purposes as well as domestic use is river Kishanganga and various nallas for dam site area and Madumati nallah, Bonar nallah for power site. Necessary pumping arrangements for supply of water and filtration/treatment facilities, if required, are to be made by the Contractor of his own.

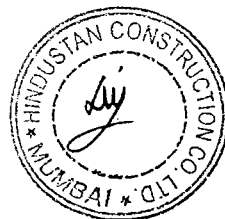

5.3 Arrangement of construction power for Contractor's use for main works and their establishment

The construction power is of vital importance for construction of any project and needs to be planned properly so that uninterrupted power is available at all times. The Contractor shall have to make his own arrangement for construction power as well as power for township/auxiliary power by his own diesel generating sets to meet their full requirement. Further, the Contractor has to provide distribution facilities and necessary safety precautions on their own.

5.4 Communication facilities available

Nearest BSNL telephone exchange is at Bandipore, a satellite exchange has been established by BSNL at Dawar (Gurez). The existing telephone system is not reliable and the contractor may have to install his own communication system like V-SAT, LDST etc. on his own.

5.5 Details about local taxes including works contract taxes leviable presently in the state of J&K

The following taxes / royalty are leviable from the Contractor: -

- a) Works Tax (J&K. Sales tax)
- b) Royalty on boulders, aggregates, etc.
- c) Sales tax on royalty.
- d) Income tax on payments.
- e) Excise duty as applicable.
- f) Customs duty on imports

J&K entry tax on the goods shall be chargeable at Lakhanpur as per Schedule I&II of J&K entry tax on Goods Act 2000.

The above is meant for general information only and the Bidder should verify the same for rates and additional taxes/levies etc. if any, before filling his price Bid.

5.6 Inner line permit / Pass, if required for contractors and his workmen

Inner line permit/ pass is not required in the state of J&K at present. However, for foreign national, the inner line permit/pass may be required.



5.7 Availability of nearest fuel station

The Contractor has to make arrangement for his own fuel station having sufficient storage capacity for meeting his petrol and HSD requirement. The nearest fuel station is available in Sopore town only which is 30 km from Bandipore (and extension counter located at Bandipore), while Indian Oil depot is available at Srinagar.

5.8 Issue of materials to the contractor

All the construction material required for the construction of Project shall have to be arranged by the Contractor himself. In view of the availability of approach by road for only 5-6 months in a year at dam site, sufficient storage shall be required to be created by the Contractor to ensure the availability of construction material and machinery required for full year working.

5.9 Law and Order situation

The proposed Dam site, located in Gurez valley falls within the shelling range from Pakistan border. The proposed Powerhouse site is located near Bandipora town and its surrounding areas have witnessed sporadic incidents of militancy and hence vulnerable to security. Incidents of militancy in and around the Project Area are reported in national and international media from time to time. The Owner shall be providing general security for the Project through CISF/BSF. However the Contractor will be responsible for any additional security in terms of G.C.C, Article 11.2.

5.10 Other relevant information

The manpower engaged by the Contractor for the works of the project shall be mainly from local population to the extent available. However, in case of non-availability of highly skilled/semi skilled manpower among local population, the same shall be arranged from outside Gurez/Bandipora.

Reduction in efficiency of man and machinery in high altitude may be taken care of by the tenderers while quoting tender bids.

The project has only 500 Kg portable explosive license at dam site and 400 Kg portable explosive license at power house site. The Contractor shall have to arrange his own explosive magazine and the license of the capacity as per his requirement.

The location of the batching plant, crushing plant and other installations etc. shall be finalized by Contractor himself as per his convenience and as per the convenience of local people/administration.

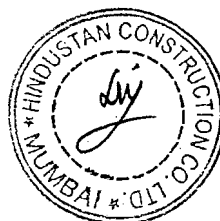

Bidder's Appreciation Of The Project

Our technical team comprising of experienced Engineers have visited the site at different times. The team made first site visit in last week of September 2006 and second site visit in last week of October 2006.

This appreciation is broadly based on our site visit and gives an account of our understanding of all principal technical and logistic problems related to transportation and installations, handling of the construction equipments, materials, and availability of land, infrastructures, local taxes and laws and construction of works.

Following is a summary of various aspects of the project, which is based on, our site visits and information collected:

- o Location of the site and Access to the site from railhead, airport and highways and large cities.
- o Project Roads – Permanent and temporary
- o Problems related to transportation and erection of heavy construction equipments.
- o Quarries and borrow areas for aggregates, sand and clay
- o Source of cement, steel, explosives and other material and transport & storage.
- o Rainy season, river flows and river banks
- o Disposal areas
- o Location/land for site installations like crushing plant, batching plant, site offices, stores, workshop and colony for officers, staff and workers etc.
- o Water and Power supply
- o Communication, medical banks, post office.
- o Local conditions – Local taxes and laws.
- o Other project specific matters.

Above aspects are explained in detail below:

1.1 Location of the site and Access to the site from railhead and highways and large cities

The Kishanganga HE project is located in the state of Jammu and Kashmir. Logistically the project has been divided in to two work centers one at powerhouse and other at Dam site (Gurez valley). Dam site, Part of HRT (inlet adit and Adit-I) of the project is located in Gurez valley and Surge shaft, pressure shaft and powerhouse are near Bandipora in Kashmir valley. Srinagar is the nearest city, well connected by Air. Following table gives the approximate distances of Project from various important cities

	Dam Site	Powerhouse site
From Delhi	1025 Km	955 Km
From Jammu	440 Km	370Km
From Srinagar	140 Km	70 Km

Structures from surge to powerhouse are located near Bandipora and can be accessed using NH-1A and 50km limb NH connecting NH-1A at Srinagar to

Bandipora. On this route, there are bridges with carriage capacity varying from 70R to 18R. Wherever low capacity bridges are located we can cross the Nallah through the bed during lean season.

Dam complex (Gurez valley):

Road from powerhouse to dam site is predominantly class 9H except for about 20 km which is of class-9. On this stretch, there are bridges with carrying capacity varying from 24R to 18R. All Nallahs can be crossed through bed during lean season.

Jammu is the nearest BG railway head and Srinagar is the nearest airport. All materials and equipments will have to be transported from Jammu by utilizing NH-1A.

1.2 Project Roads – Permanent & Temporary

The present statuses of roads, which have been inspected by us during our site visit, are as under:

- o The principal access road to the site is NH-1A: Slopes above the road have become unstable along certain stretches and frequent landslides during monsoon block the roads. BRO is undertaking the road clearing activity in case of blockages.
- o Srinagar – Bandipora road: This road is NH-1A and 50km limb of NH connecting NH-1A at Shetang to Bandipora. Generally the road width is 7-10m but somewhere the width is restricted to 4m only. On this route, there are bridges with carriage capacity varying from 70R to 18R. Wherever low capacity bridges are located we can cross the Nallah through the bed during lean season.
- o Bandipora – Surge shaft top stretch of road: Length of this road is 21 km and it is class 9H with ruling gradient and formation width of 5.95m. There is a 24 R class steel bridge across Madumati Nallah at 3 km of this road. The length of this bridge is about 76-M. At the same location BRO is constructing a “70 R” class RCC Bridge and length is about 55m.
- o Bandipora – Dam site road: Length of this road beyond surge shaft top is 51 km, having varying width from 5.95m - 7.45m. This road during winter months due to heavy snow fall remains blocked and remains open only for 5-6 months i.e. May/June to November in a year.
- o Bridge details: In the following table we have given the details about the various bridges in project area

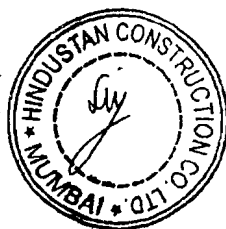

Kishanganga HE Project
Vol-IV: Bid Proposal Sheets
Data Sheet - 1

Chainage In Km	Type of Bridge	Length (m)	Loading capacity
55	SSRBB type	21.34	24R
59.5	SSRBB type	18.29	24R
66	HAMILTON type	18.29	18R
66.95	TSRBB type - Kanjalwan bridge over Kishanganga river	44.12	18R
71.80	TSRBB - Mallai Kadal bridge	42.87	24R
72.2	HAMILTON type	12.19	18R

However, where existing bridges have inadequate capacity, the Nallahs may be crossed through the bed during lean season. Some temporary measures like new access, filling & clearing later may be required at these locations.

The project foresees following permanent access roads, which are required to be constructed by the EPC contractor.

- o To main access tunnel
- o To switchyard / ventilation tunnel
- o To tail race outlet
- o To various adits of pressure shaft
- o To surge shaft bottom and for TBM tunneling
- o To surge shaft top

Apart from above permanent roads following temporary roads have to be constructed for construction purposes.

- o Construction access on left bank and right bank
 - o Temporary haul roads in Dam complex
 - o Temporary roads in powerhouse
 - o Various access roads to batching plants, crushing plant, colony area etc.
- Temporary access road can be designated to an average 10% gradient, taking into consideration of traffic ability of hauling equipment.
A bridge over Dudkhatu nallah near Intake adit is also required.

1.3 Problems related to Transportation and erection of heavy construction equipments:

Problems in Equipment transport

Construction equipments required are dozers, excavators, drilling jumbos, batching plant (to be brought in parts), crushing plant (in parts), concrete-placing arrangements etc. These equipments will come from all parts of the country. Tunnel Boring machine and certain E&M equipments are to be imported in parts and will come from Mumbai / Kandla port.



Kishanganga Consortium

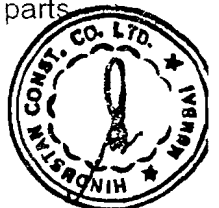
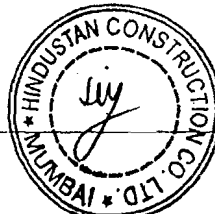

All of these equipments will have to be transported by road from port or from other source. These will travel first to Jammu and via NH 1A to Bandipore. While traveling through NH 1A, the equipments will have to pass through Jawahar tunnel, which has size limitation. So, we keep an options of (a) unloading these equipments, specially the parts of E&M / HM equipments which have larger sizes, to certain terrace like plots on either sides (approximately 20 km) of NH 1A and transship them on smaller vehicles or (b) Design the TBM specially cutter head and other components including EM equipments suitable to pass the tunnel and also the road conditions beyond Bandipore.

The road from Bandipore to Gurez valley has lesser width and vehicles with 7-8 tons load can access through. The road has to be strengthened at some places. During material and equipment transportation we have to avoid traffic congestion and road accidents by taking following measures:

- o Load trucks / trailers only to allowable capacities keeping in view the gradient and nature of roads and also the pulling power of the vehicle.
- o Heavily loaded vehicles will generally travel during nighttime when traffic will be minimum, so as to minimize traffic congestion.
- o If needed, organize a dummy load to run along the route to understand the problems.
- o Employ experienced agencies for transportation of equipments / materials.
- o Dismantle all the heavy equipments in such a manner so that their transportation over the bridges and Jawahar tunnel is within permissible limits.

Problems in Equipment erection:

- (a) Crushing plant: We do not envisage any problem in the erection of crushing plants.
- (b) Batching plants, cement storage, aggregate bins: We do not envisage any problem in the erection of these equipments.
- (c) Concrete placing arrangements: We do not envisage any problem in the erection of concrete placing arrangement.
- (d) TBM: TBM can be erected on the flat terrace near the proposed portal of TBM adit / adit-2.

1.4 Quarries and borrow areas for aggregate, sand and clay.

NHPC have carried out detailed investigations for availability and testing of construction materials for use as concrete aggregate, rock fill material, semi-pervious material and impervious soil. In total twelve river bed deposits / shoals, three rock quarries, three deposits of semi-pervious material and three impervious soil deposits have been investigated. These have been listed in the Vol-I of Tender document.

We have visited the deposits and checked their feasibilities. In addition to the material sources as above, use of excavated material from open excavation, riverbed excavation, tunnel excavation and powerhouse excavation as concrete aggregate and rock fill materials can also be considered.



EXHAUST FAN

BEAM FIXED ENTRANCE

4250

3200

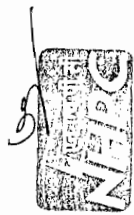
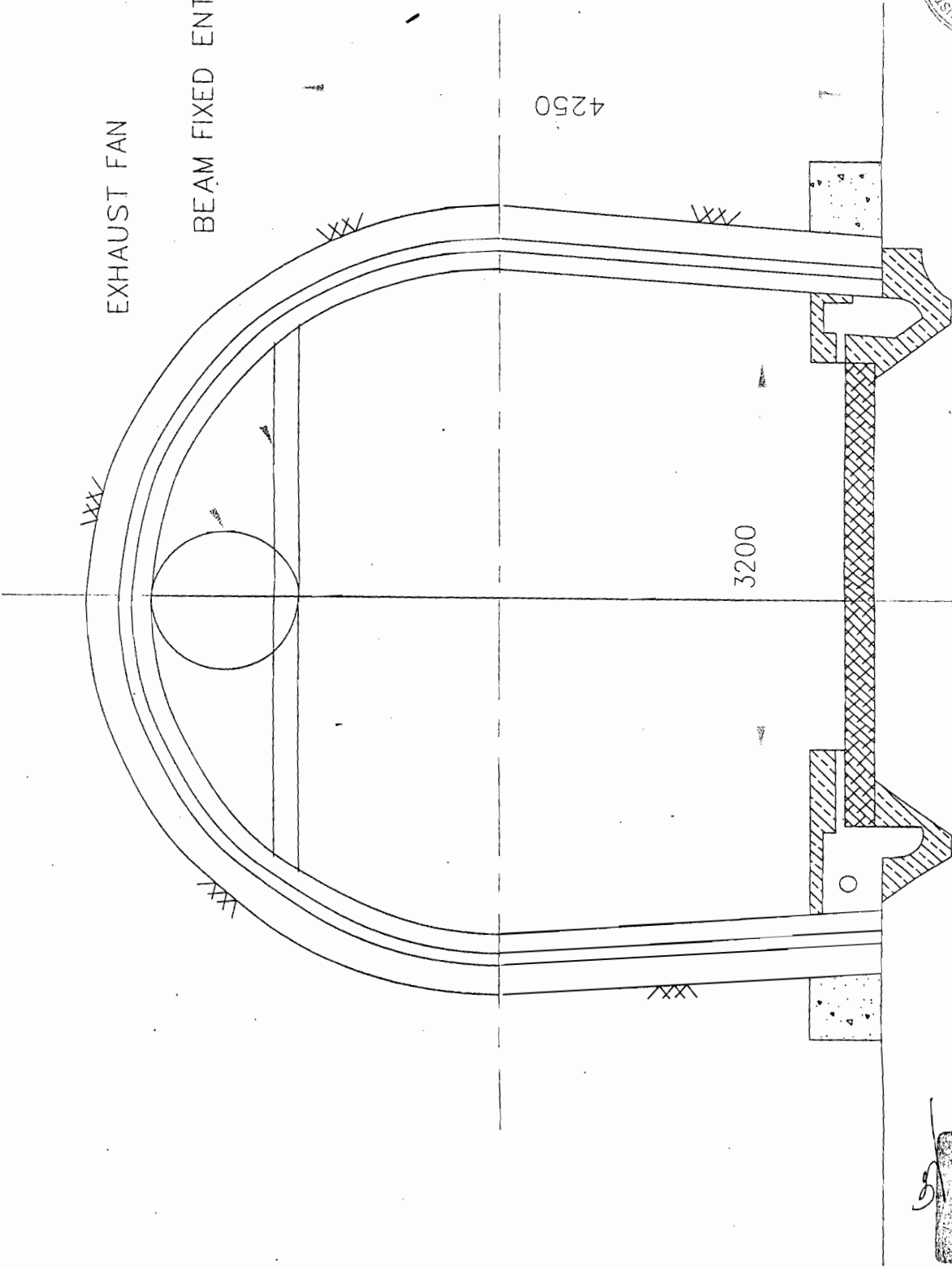

C/S OF JAWAHAR TUNNEL NH-1A

SECTION - 4

GUARANTEED TECHNICAL PARTICULARS FOR CIRCUIT BREAKERS

1 General

- a) Name of the Manufacturer
- b) Country of Manufacture
- c) Type of Circuit Breaker
- d) Manufacturer's type designation
- e) Standard Applicable
- f) Rated Voltage (kV rms)
- g) Rated Current
 - i) Under normal condition (A)
 - ii) Under site condition (A)
- h) Rated frequency (Hz)
- i) Number of poles
- j) Whether 3 pole or single pole unit
- k) Whether All The 3 poles ganged electrically or mechanically
- l) Whether dead tank or live tank design
- m) Type of installation
- n) No. of break per pole
- o) Latching Current

2. Guaranteed Ratings

- a) Rated short circuit breaking current
 - i. Symmetrical component at at highest system voltage (kA)
 - ii. DC Component (%)
 - iii. Asymmetrical breaking current at highest system voltage (kA)
- b) Rated Making Capacity
 - i. At higher rated voltage (kAp)
 - ii. At lower rated voltage (kAp)
- c) i. Maximum Total break time under any duty condition for any current upto rated breaking current with limiting conditions of voltage and pressure (ms)
 - ii. Rated break time
- d) Closing time (ms)
- e) Minimum opening time under any condition with limiting voltage and pressure (ms)
- f) Maximum opening time under any condition with limiting voltage and pressure (ms)
- g) Maximum close open time under any condition with limiting voltages and pressures (ms)
- h) First pole to clear factor
- l) Short time current rating (kA) for 1s/3s
- j) Rated operating duty
- k) Maximum braking capacity under kilometric faults and rated TRV characteristic (kAp)
- l) Maximum breaking capacity under

phase opposition (kAp)

- m) Maximum line charging breaking current with temporary over voltage upto 1.4 p.u. (A)
- n) Maximum over voltage (p.u.) on switching transformer on no load and corresponding charging current
- o) Maximum period between closing of first contact & last contact in a pole (ms)
- p) Maximum pole discrepancy (ms)
- q) Maximum arc duration and corresponding current under lockout pressure
- r) Pre-insertion resistor
 - i. Value/ pole(ohms)/ with tolerance
 - ii. Minimum and maximum duration of insertion per pole (ms)
 - iii. Thermal rating for the C-1m-O-CO-2m-C-1m-O-CO for terminal fault considering maximum resistance and
 - iv. Thermal rating for the same duty as (iii) above for reclosing against trapped charges
- s) Small fault current breaking capacity (kAp)
- t) Maximum temperature rise for main contacts over design ambient temperature of 50°C
- u) Rated voltage & pick up range for trip coil (V)
- v) Rated voltage & pick up range for closing coil (V)
- w) Rated pressure and limits of

pressure of operating
mechanism

- x) Rated pressure and limits of
pressure of extinguishing medium
- y) Minimum dead time for
 - i) Three phase reclosing (ms)
 - ii) Single phase reclosing (ms)

3. Dielectric withstand of complete Breaker

- a) One minute dry & wet power
frequency withstand voltage
 - i. Between live terminal and
ground (kV rms)
 - ii. Between terminals with breaker
contacts open (kV rms)
- b) 1.2/50- micro second impulse
withstand test voltage
 - i. Between live terminals and
ground (kVp)
 - ii. Between terminals with breaker
contacts open (kVp)
- c) 250/2500 micro second switching
surge withstand test voltage
 - i. Between live terminals and
ground (kVp)
 - ii. Between terminals with breaker
contacts open (kVp)
- d) Corona extinction voltage (kV rms)
- e) Maximum radio interference
voltage (micro V) at $1.1 U_r/_/3$
- f) Total creepage distance
 - i) To ground (mm)
 - ii) Between terminals (mm)

4. Operating Mechanism

- a) Type of operating mechanism for

- i. Closing
- ii. Opening

b) Manufacturer's type designation

- c) Normal power consumption (W)
at rated voltage of
- i) Trip coil
 - ii. Closing coil

4.1 **Pneumatic operating mechanism**

- a) Rated operating pressure
(kg/sq.cm)
- b) Range of pressure for (kg/sq.cm)
 - i. Closing
 - ii. Opening
- c) Air Consumption at rated
pressure for
 - i. Closing (m³)
 - ii. Opening (m³)
 - iii. Close-open (m³)
- d) Pressure drop/ meter length of piping
- e) Number and Capacity (m³) of
breaker local air storage receivers
- f) No. of close operations for which
sufficient air is available in local receiver
- g) Capacity of compressor (m³/hr)
and working pressure (kg/cm²)
- h) Maximum time for which
compressor can operate
continuously (min)
- l) Time to fill
 - i) Air receiver after one CO
operation (min)
 - ii) For making up of losses
occurring in 4 hours (min)
- j) Pressure at which compressor
 - i) Starts (kg/cm²)
 - ii) Stops (kg/cm²)
- k) Material of compressed air piping
- l) Inner & outer dia of main piping (mm)
- m) Whether interpole piping included
in scope of supply
- n) Manufacturer's name for

- i) Compressor
- ii) Air receiver
- iii) Pressure reducer
- iv) Stop valves
- v) Drain valves
- a) Safety valve
 - i) Low pressure stage
Blow off at (kg/ cm²)
 - ii) Intermediate stage blow
off at (kg/cm²)
 - iii) High pressure stage blow
off at (kg/ cm²)
- p) Safety valve opens at (kg/cm²)
- q) No. of stored CO operation in
breaker air receiver
- r) Alarm switch closes on air
receiver at (kg/cm²)
- s) Lockout pressure (kg/ cm²)
 - i) Closing
 - ii)
 - iii)

4.2 **Spring charged mechanism**

- a) Number of close open operations
possible after failure of AC
supply to motor
- b) Time required for motor to
charge the closing spring (min)
- c) Whether indication of spring
charged condition provided in
central control cabinet

5. **Type of Breakers**

5.1 SF6 Circuit Breakers

- a) Quantity of SF6 per pole (m³) at
rated pressure
- b) Guaranteed maximum leakage
rate per year
- c) Rated pressure of SF6 in

operating chamber

- d) Limit of pressure at which breaker operates correctly (kg/ cm²)
- e) Standard to which SF₆ gas complies
- f) Whether 20% spare SF₆ gas stores in unused gas cylinder, included in proposal
- g) Capacity & filling ratio of containers in which SF₆ gas would be shipped (m³)
- h) Whether breakers are dispatched filled with SF₆ or required to be filled at site
- i) Type and make of SF₆ pipe coupling used
- j) Type and make of mandatory maintenance equipment
 - i. SF₆ gas filling and evacuation trolley (portable)
 - ii. SF₆ gas drying, filling, evacuating equipment and its capacity
 - iii. Operating analyzer type and make
 - iv. SF₆ gas leak detector
- k) Parameters of SF₆ gas for initial filling & satisfactory operation
 - i. Density
 - ii. Dielectric strength/ kVmm
 - iii. Acidity (ppm)
 - iv. Water content (ppm)
 - v. Oil content (ppm)
 - vi. Condensation temperature °C)
 - vii. Resistivity (Ohm-cm)
- l) Whether details of SF₆ gas viz test

methods, handling etc. enclosed

- m) Type and material of gasket used to ensure gas tight joints for
 - i. Metal to metal joints
 - ii. Metal to porcelain joints
- n) Method of housing SF6 gas compressors and equipment
 - i. At circuit breaker
 - ii. In control cubicle
- o) Type and make of
 - i. Density meter
 - ii. Pressure gauge
- p) Density meter Settings
 - i. Lockout
 - ii. Alarm
- q) Minimum time interval between each make/ break operation (ms)

5.2 General

- a) Whether OGA drawing enclosed
- b) Weight of complete 3 phase breaker for foundation design (kg)
- c) Weight of heaviest part of breaker (kg)
- d) Impact loading for foundation design
- e) Seismic level for which breaker is designed
- f) Minimum safety clearance from earthed objects
- g) Noise level in (dB) at base of the breaker

- h) Minimum clearance in air
 - i. Between live parts (mm)
 - ii. Live parts to earth (mm)
 - iii. Live parts to ground level (mm)

6. Constructional Details

- a) Whether arcing contacts provided
- b) Type and material of main contacts and arcing contacts
- c) Contact pressure on main contacts (kg/ cm²)
- d) Contact separation in arcing position (mm)
- e) Contact separation in open position (mm)
 - i. Main contacts
 - ii. PIR contacts
- f) Whether pressure relief device for each of the gas chamber of SF₆ CB provided
- g) Rate of contact travel
 - i. Opening (m/sec)
 - ii. Closing (m/sec)
- h) Whether the making & breaking contacts are hermetically sealed
- l) Type and capacity of device used to obtain uniform voltage distribution between breaks
- j) Over voltage withstand capability of grading components (kV/mms)
 - i) Continuous
 - ii. 10 minutes
 - iii. 1 minute
 - iv. 5 seconds

- k) Number of auxiliary contacts per pole provided for Owner's use
- l) Rated voltage of auxiliary contacts (V)
- m) Current rating of auxiliary contacts
 - i. Continuous (A)
 - ii. DC breaking with 20 ms time constant (A)
- n) Whether auxiliary contacts silver plated
- o) Whether support structure included in supply
- p) Height of support structure
- q) Material of support structure
- r) Standard to which the design of support structure conforms
- s) Whether foundation bolts for breakers and cabinets included in scope of supply

7. Detailed Literature

- a) i. Type test reports as per IEC-56
 - ii. Factory test report & /or filed test report in case of reactor switching duty
 - iii. Details of operating mechanism
 - iv. Drawing of breaker of support structure
 - v. Calculations for compressed
 - vi. Details of SF6 gas filling
 - vii. Details of SF6 gas leak detector
 - viii. Precaution in use of SF6 gas
 - ix. Leaflets & literature bringing out salient features of equipment offered
- x) Schematic diagrams of switching mechanism for closing resistor

- showing the duration of insertion along with calculation for thermal rating of closing resistors
- xi. Whether drawings/data data furnished as per cl.12 of chapter switchgear (CB)
 - xii. Method of checking of voltage distribution devices at site enclosed
 - xiii. Details alongwith a complete catalogue of operation analyzer enclosed
 - xiv Data on capabilities of circuit breaker in terms of time and number of operations at duties ranging from 100% fault currents to load currents of the lowest possible value without requiring any maintenance or checks
 - xv) Effect of non simultaneity between contact within a pole or between poles and also show how it is covered in the guaranteed rated break time.
 - xvi) Details and type of filters used in interrupter assembly and also the operating experience with such filters
 - xvi) Curves supported by test data indicating the opening time under close open operation with combined variation of trip coil voltage & pneumatic/ hydraulic pressure
 - xvii) All duty requirements specified alongwith adequate test reports

8. CONTROL CABINETS

1. Manufacturer's Name
2. Indoor/ Outdoor application
3. Design ambient air temperature (deg. C)

220/33kV Switchyard for Kishanganga (3x110MW) HEP for NHPC Limited

Technical Specification Doc.No. TB 329 316 008 Rev.00

220kV & 33kV Outdoor Circuit Breaker

4. Standards applicable
5. Thickness of sheet steel (mm) and whether cold rolled or hot rolled
6. Degree of protection provided
7. Bill of material for all the equipment mounted on control cabinet giving the following details
 - a) Make and type
 - b) Applicable Standard
 - c) Voltage rating
 - d) Current rating
 - e) Duty class, if applicable
 - f) Manufacturers catalogue No.
 - g) Total heat load of cabinet
(for purpose of ventilation requirement)
8. Colour of finish paint IS:5
 - a) Outside
 - b) Inside
9. Control Wiring
 - (a) Size of conductor
 - i. For CT circuits
 - ii. For other circuits
 - b) Conductor Solid/ Standard
 - c) Number of Strands/ conductor
10. Terminal Blocks
 - (a) Make & type
 - b) Current rating
 - i) Power terminals (A)
 - ii) Other terminals (A)
11. Space Heater Rating at 240 V AC
12. Control cabinet drawing showing the following
 - a) Outline dimensions, floor

openings, floor/ wall/ pedestal
fixing arrangements, weights etc.

b) Front view, inside view showing
the mounting arrangement of
various equipment

13 Schematic/ Wiring diagram of
control cabinet enclosed

14 Interconnection drawing showing
cable, connections to the control
cabinet enclosed

15 Type test report to verify design
of protection enclosed

16 Details of terminal rows:

- i) Whether arranged
vertical or horizontal
- ii) Clearance from adjacent components
- iii) Distance between rows
- iv) Whether transparent protection cover
provided

9. BUSHING/SUPPORT INSULATOR

1. Manufacturer's Name
2. Type
3. Applicable Standards
4.
 - i) Height
 - ii. Diameter (Top)
 - iii. Diameter (Bottom)
5. Total Creepage distance (mm)
6. Rated voltage (kV)
7. Power frequency withstand voltage for
1 Min. (kV rms) dry and wet
8. 1.2/50 micro sec. Impulse

220/33kV Switchyard for Kishanganga (3x110MW) HEP for NHPC Limited

Technical Specification Doc.No. TB 329 316 008 Rev.00

220kV & 33kV Outdoor Circuit Breaker

- withstand voltage (kVp)
9. 250/2500 micro sec. Switching impulse withstand voltage (kVp) dry and wet
 10. Corona Extinction voltage (kV)
 11. Weight (kg)
 12. Max. Allowable span (mm)
 13. Cantilever Strength (kg)
 14. OGA drawing enclosed

SECTION - V

Manufacturing Quality plan

Attached Quality Assurance Plan (Model) for SF6 & Vacuum Circuit Breaker, page no. 1 to 7 of 37 shall be followed.

12.MODEL QUALITY ASSURANCE PLAN (QAP) FOR OUTDOOR POTHEAD YARD EQUIPMENT

Special instructions: -



1. Contractors/Manufacturers/Sub-suppliers are advised to submit QAP for equipments/ materials after incorporating all tests for bought out items, in process inspection and final inspections as per their latest manufacturing practice and Indian/ International Standards (with latest amendments, if any).
2. Contractors/Manufacturers/Sub-suppliers are required to use properly calibrated instruments /equipments during testing/inspection, for which necessary calibration certificates are required to be provided/presented to the Inspecting Officer.
3. Contractors/Manufacturers/Sub-suppliers have to make on their own all arrangements for testing facilities at their works for testing of equipments/materials.
4. One set of complete test certificates as per the requirement of QAP be made available to the Inspecting Officer at the time of inspection/testing.
5. All the records, as per the requirement of QAP are to be made available for review by the Inspecting Officer during inspection.
6. Field tests are to be carried out as per the requirements of the contract / purchase order.



QUALITY ASSURANCE PLAN (MODEL)

PROJECT : KISHANGANGA H.E. Project
 NAME OF EQUIPMENT : SF6 circuit Breaker

CLIENT : NATIONAL HYDROELECTRIC POWER CORPORATION LTD.,
 VENDOR :
 NITP.O. REFERENCE :

SR. NO.	ITEM /COMPONENTS & CHARACTERISTICS	NATURE OF CHECKS	QUANTUM OF CHECKS	REFERENCE DOCUMENTS	ACCEPTANCE NORMS	RECORD FORMAT	INSPECTION AGENCY			REMARKS
							Perform	Witness	Verify	
A)	Brought Out Items									
1	Porcelain Insulator	Visual	100%		-do-	TC	2/3	-	1	TC
1.1	A/C Insulator/ H/C Insulator	Visual Inspection								
	Dimension Check	Measurement	Sample Plan		-do-	TC	2/3	-	1	TC
	Porosity Test	Test	-do-		-do-	TC	2/3	-	1	TC
	Temp Cycle Test	Test	-do-		-do-	TC	2/3	-	1	TC
	Ultrasonic Test	Test	100%		-do-	TC	2/3	-	1	TC
	Pressure Test (Hydraulic Test)	Test	100%		-do-	TC	2/3	-	1	TC
1.2	Porcelain Insulator(Cemented)									
	Dimension Check	Measurement	Sample Plan		-do-	TC	2/3	-	1	TC
	Bending Load Test in 4 direction at 70% specified bending load	Test	100%		-do-	TC	2/3	-	1	TC
2	SF6 Gas tight die / sand casting									
2.1	Crank Housing	Visual	100%		-do-	TC	2/3	-	1	TC
	Visual Inspection	Test	Sample Plan		-do-	TC	2/3	-	1	TC
	Hardness	Test	Sample Plan		-do-	TC	2/3	-	1	TC
	Chemical composition check	Test	Sample Plan		-do-	TC	2/3	-	1	TC
	Mechanical test	Test	Sample Plan		-do-	TC	2/3	-	1	TC
	Leakage test	Test	100%		-do-	TC	2/3	-	1	TC
3	Operating rod	Visual	100%		-do-	TC	2/3	1	1	TC
	Visual Inspection	Test	Sample Plan		-do-	TC	2/3	1	1	TC
	Dimension Check	Measurement	Sample Plan		-do-	TC	2/3	1	1	TC
	Tensile load	Test	Sample Plan		-do-	TC	2/3	1	1	TC

Note: a. In 'Inspection Agency' column figure 1,2, or 3 to be filled. 1- will indicate 'NHPCC', 2- will indicate 'supplier' & 3- will indicate 'sub-supplier'.
 b. In 'Remarks' column following abbreviations shall be used - RR-Review of Records, T.C. - Test Certificate Submission & CHP- Customer Hold Point.
 c. Test certificates shall be submitted at the time of final inspection.



7229

FI/QA/740/01/01
 Rev.-01

Signature
 NHPCC (QA&I DEPT.)

Signature & Seal
 (VENDORS Q.C. DEPT. OR REPRESENTATIVE)

PROJECT : KISHANGANGA H.E. Project
 NAME OF EQUIPMENT : SF6 circuit Breaker

CLIENT : NATIONAL HYDROELECTRIC POWER CORPORATION LTD.
 VENDOR : NHPC
 NIT/P.O. REFERENCE :

SR. NO.	ITEM /COMPONENTS & CHARACTERISTICS	NATURE OF CHECKS	QUANTUM OF CHECKS	REFERENCE DOCUMENTS	ACCEPTANCE NORMS	RECORD FORMAT	INSP. AGENCY		REMARKS	
							Perform	Witness		Verify
4	Nozzle Visual inspection Dimensional check	Visual measurement	100% sample plan	Tech. Spec./ Appd. Drg.	-do- -do-	TC TC	2/3 2/3	- -	1 1	TC TC
5	Arching contacts Visual inspection Dimensional check Chemical composition check	Visual measurement test	100% sample plan	-do- -do- -do-	-do- -do- -do-	TC TC TC	2/3 2/3 2/3	- - -	1 1 1	TC TC TC
6	'O' Ring surface defects Dimensional check	Visual measurement	100% sample plan	-do- -do- -do-	-do- -do- -do-	TC TC TC	2/3 2/3 2/3	- - -	1 1 1	TC TC TC
7	Hardness material base Ageing in Air Springs Dimensional check	measurement test test	sample plan sample plan sample plan	-do- -do- -do-	-do- -do- -do-	TC TC TC	2/3 2/3 2/3	- - -	1 1 1	TC TC TC
8	Motor Load test H V Test Casting(Lever)	electrical electrical	100% 100%	-do- -do- -do-	-do- -do- -do-	TC TC TC	2/3 2/3 2/3	- - -	1 1 1	TC TC TC
9	No casting defects Dimensional check	Visual measurement	100% sample plan	-do- -do-	-do- -do-	TC TC	2/3 2/3	- -	1 1	TC TC

Note: a. In 'Inspection Agency' column figure 1,2, or 3 to be filled. 1- will indicate 'NHPC', 2- will indicate 'supplier' & 3- will indicate 'sub-supplier'.
 b. In 'Remarks' column following abbreviations shall be used - RR-Review of Records, T.C. - Test Certificate Submission & CHP - Customer Hold Point.
 c. Test certificates shall be submitted at the time of final inspection.

730
 F/10A/740/01/01
 Rev.-01



Signature
 NHPC (QA&I DEPT.)

Signature & Seal
 (VENDORS Q.C. DEPT. OR REPRESENTATIVE)



PROJECT : KISHANGANGA H.E. Project
 NAME OF EQUIPMENT : SF6 circuit Breaker

CLIENT: NATIONAL HYDROELECTRIC POWER CORPORATION LTD.
 VENDOR :
 NIT/P.O. REFERENCE :

QUALITY ASSURANCE PLAN (MODEL)

SR. NO.	ITEM /COMPONENTS & CHARACTERISTICS	NATURE OF CHECKS	QUANTUM OF CHECKS	REFERENCE DOCUMENTS	ACCEPTANCE NORMS	RECORD FORMAT	INSP. AGENCY			REMARKS	
							Perform	Witness	Verify		
10	Density Monitor										
	Leakage test	Test	100%	Tech. Spec/ Appd. Drg.	-do-	TC	2/3	-	1	TC	
	HV test(2KV for 1 minutes)	Test setting	100%		-do-	TC	2/3	-	1	TC	
11	Structure	Measurement	sample plan		-do-	TC	2/3	-	1	TC	
	Dimension check	Measurement	sample plan		-do-	TC	2/3	-	1	TC	
12	Galvanising										
	SF6 Gas										
	Purely,dew Point,Leakage test	test	100%	Tech. Spec./ IEC: 376,376A,376B		TC	2/3	-	1	TC	
B	Routine Test										
1	Mechanical Operations	Test/Checks/ Measurement									
		At 100 % V	-do-	100%	Tech. Spec/ Appd. Drg./IEC 56	JIR	2/3	1	-	CHP	
		At 85%V for closing	-do-	-do-		JIR	2/3	1	-	CHP	
		At 70% V for tripping	-do-	-do-		JIR	2/3	1	-	CHP	
		At 110% V for Closing	-do-	-do-		JIR	2/3	1	-	CHP	
		At 110% V for Tripping	-do-	-do-		JIR	2/3	1	-	CHP	
		Measurement of Speed, Time & Travel Contact									
		At 100 % V	-do-	-do-		JIR	2/3	1	-	CHP	
		At 85%V for closing	-do-	-do-		JIR	2/3	1	-	CHP	
		At 70% V for tripping	-do-	-do-		JIR	2/3	1	-	CHP	
At 110% V for Closing	-do-	-do-		JIR	2/3	1	-	CHP			
At 110% V for Tripping	-do-	-do-		JIR	2/3	1	-	CHP			
3	Gas leakage Test										
	Measurement of Contact resistance(mill volt) on pole column	-do-	-do-		-do-	JIR	2/3	1	-	CHP	

Note: a. In 'Inspection Agency' column figure 1,2, or 3 to be filled. 1- will indicate 'NHPG', 2- will indicate 'supplier' & 3- will indicate 'sub-supplier'.
 b. In 'Remarks' column following abbreviations shall be used - RR-Review of Records, T.C. - Test Certificate Submission & CHP - Customer Hold Point
 c. Test certificates shall be submitted at the time of final inspection.



731

FI/QA/740/01/01
 Rev.-01

Signature
 NHPG (QA&I DEPT.)

Signature & Seal
 (VENDORS Q.C. DEPT. OR REPRESENTATIVE)

QUALITY ASSURANCE PLAN (MODEL)

PROJECT : KISHANGANGA H.E. Project
 NAME OF EQUIPMENT : SF6 circuit Breaker

CLIENT : NATIONAL HYDROELECTRIC POWER CORPORATION LTD.
 VENDOR : NHPC
 NIT/P.O. REFERENCE :

SR. NO.	ITEM /COMPONENTS & CHARACTERISTICS	NATURE OF CHECKS	QUANTUM OF CHECKS	REFERENCE DOCUMENTS	ACCEPTANCE NORMS	RECORD FORMAT	INSP. AGENCY		REMARKS
							Perform	Witness	
5	Functional / wiring check	Test/Checks/ Measurement	sample plan	Tech. Spec/ Appd. Drg./IEC 56	JIR	JIR	2/3	-	CHP
6	Anti-pumping check	-do-	-do-	-do-	JIR	JIR	2/3	-	CHP
7	2Kv test on Control circuit / auxiliary circuit	-do-	-do-	-do-	JIR	JIR	2/3	-	CHP
8	Coil resistance measurement	-do-	-do-	-do-	JIR	JIR	2/3	-	CHP
9	One minute power frequency withstand test on circuit breaker	-do-	-do-	-do-	JIR	JIR	2/3	-	CHP
10	spring charging time & motor current verification of operation of density monitor switch	-do-	sample plan	-do-	JIR	JIR	2/3	-	CHP
11	Travel measurement of main contacts & closing spring	-do-	100%	-do-	JIR	JIR	2/3	1	CHP

Note: a. In 'Inspection Agency' column figure 1, 2 or 3 to be filled. 1- will indicate 'NHPC', 2- will indicate 'supplier' & 3- will indicate 'sub-supplier'.
 b. In 'Remarks' column following abbreviations shall be used - RR-Review of Records, T.C. - Test Certificate Submission & CHP - Customer Hold Point.
 c. Test certificates shall be submitted at the time of final inspection.

F/I/Q/A/T/40/01/01
 Rev.-01

Signature
 NHPC (QA&I DEPT.)

Signature & Seal
 (VENDORS Q.C. DEPT. OR REPRESENTATIVE)

732



QUALITY ASSURANCE PLAN (MODEL)

PROJECT : KISHANGANGA H. E. Project
 NAME OF EQUIPMENT : Vacuum Circuit Breaker

CLIENT : NATIONAL HYDROELECTRIC POWER CORPORATION LTD.
 VENDOR : NHPC
 NHPC O. REFERENCE :

SR. NO.	ITEM /COMPONENTS & CHARACTERISTICS	NATURE OF CHECKS	QUANTUM OF CHECKS	REFERENCE DOCUMENTS	ACCEPTANCE NORMS	RECORD FORMAT	INSP. AGENCY			REMARKS
							Perform	Witness	Verify	
A/	Brought Out Items									
1	Porcelain Insulator	Visual	100%	Tech. Spec/ Appd. dty/ IS & IEC	-do-	TC	2/3	-	1	TC
1.1	A/C Insulator/ H/C Insulator	Visual Inspection	100%		-do-	TC	2/3	-	1	TC
	Dimension Check	Measurement	Sample Plan		-do-	TC	2/3	-	1	TC
	Porosity Test	Test	-do-		-do-	TC	2/3	-	1	TC
	Temp Cycle Test	Test	100%		-do-	TC	2/3	-	1	TC
	Ultrasonic Test	Test	100%		-do-	TC	2/3	-	1	TC
	Pressure Test (Hydraulic Test)	Test	100%		-do-	TC	2/3	-	1	TC
1.2	Porcelain Insulator(Cemented)	Measurement	Sample Plan		-do-	TC	2/3	-	1	TC
	Dimension Check	Measurement	100%		-do-	TC	2/3	-	1	TC
	Bending Load Test in 4 direction at 70% specified bending load	Test			-do-	TC	2/3	-	1	TC
2	Crank Housing	Visual	100%		-do-	TC	2/3	-	1	TC
	Visual Inspection	Test	Sample Plan		-do-	TC	2/3	-	1	TC
	Hardness	Test	Sample Plan		-do-	TC	2/3	-	1	TC
	Chemical composition check	Test	Sample Plan		-do-	TC	2/3	-	1	TC
	Mechanical test	Test	Sample Plan		-do-	TC	2/3	-	1	TC
	Leakage test	Test	100%		-do-	TC	2/3	-	1	TC
3	Operating rod	Visual	100%		-do-	TC	2/3	-	1	TC
	Visual Inspection	Measurement	Sample Plan		-do-	TC	2/3	-	1	TC
	Dimension Check	Test	Sample Plan		-do-	TC	2/3	-	1	TC
	Tensile load	Test			-do-	TC	2/3	-	1	TC

Note: a. In 'Inspection Agency' column figure 1,2, or 3 to be filled. 1- will indicate 'NHPC', 2- will indicate 'supplier' & 3- will indicate 'sub-supplier'.
 b. In 'Remarks' column following abbreviations shall be used - RR-Review of Records, T.C. - Test Certificate Submission & CHP - Customer Hold Point.
 c. Test certificates shall be submitted at the time of final inspection.

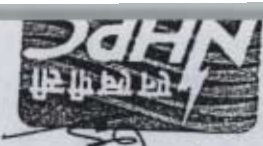

733

FI/QA/740/01/01
 Rev.-01

Signature
 NHPC (QA&I DEPT.)

Signature & Seal
 (VENDORS O.C. DEPT. OR REPRESENTATIVE)

QUALITY ASSURANCE PLAN (MODEL)

PROJECT : KISHANGANGA H. E. Project
 NAME OF EQUIPMENT : Vacuum Circuit Breaker

CLIENT: NATIONAL HYDROELECTRIC POWER CORPORATION LTD.
 VENDOR : NITP O. REFERENCE :

SR. NO.	ITEM /COMPONENTS & CHARACTERISTICS	NATURE OF CHECKS	QUANTUM OF CHECKS	REFERENCE DOCUMENTS	ACCEPTANCE NORMS	RECORD FORMAT	INSP. AGENCY			REMARKS
							Perform	Witness	Verify	
4	Vacuum Interrupter a) Make & Rating b) Power Frequency Test	Visual Electrical	100% -do-	Tech. Spec/ Appd. dng./ IS & IEC -do-	-do-	TC TC	3/2 3/2	- -	1 1	TC TC
5	Arcting contacts Visual Inspection Dimensional check Chemical composition check	Visual measurement test	100% sample plan -do-	-do- -do- -do-	-do- -do- -do-	TC TC TC	2/3 2/3 2/3	- - -	1 1 1	TC TC TC
6	'O' Ring surface defects Dimensional check Hardness material base Ageing in Air	visual measurement -do- test -do-	100% sample plan -do- -do- -do-	-do- -do- -do- -do- -do-	-do- -do- -do- -do- -do-	TC TC TC TC TC	2/3 2/3 2/3 2/3 2/3	- - - - -	1 1 1 1 1	TC TC TC TC TC
7	Springs Dimensional check Load test	measurement -do-	sample plan -do-	-do- -do-	-do- -do-	TC TC	2/3 2/3	- -	1 1	TC TC
8	Motor Load test H V Test	electrical -do-	100% -do-	-do- -do-	-do- -do-	TC TC TC	2/3 2/3 2/3	- - -	1 1 1	TC TC TC
9	Castings(Lever)s No casting defects Dimensional check Switches, Relays & Timers.	visual measurement	100% sample plan	-do- -do-	-do- -do-	TC TC	2/3 2/3	- -	1 1	TC TC
10	Make, Type & Rating Operational Test High Voltage test	Visual Electrical -do-	100% -do- -do-	Tech. Spec/ Appd. dng./IS:2959 -do- -do-	-do- -do-	TC TC TC	2/3 2/3 2/3	- - -	1 1 1	TC TC TC

Note: a. In 'Inspection Agency' column figure 1,2, or 3 to be filled. 1- will indicate 'NHPC', 2- will indicate 'supplier' & 3- will indicate 'sub-supplier'.
 b. In 'Remarks' column following abbreviations shall be used - R/R-Review of Records, T.C. - Test Certificate Submission & CHP - Customer Hold Point.
 Test certificates shall be submitted at the time of final inspection.



Rev-01
 EHEAD/4001/101



Signature
 NHPC (QA&I DEPT.)

Signature & Seal
 (VENDORS O.C. DEPT. OR REPRESENTATIVE)

CHECK LIST FOR 220 & 33 KV CIRCUIT BREAKERS

BIDDERS ARE INSTRUCTED TO WRITE 'YES' UNDER CLOUMN '2', IF THE INFORMATION / SCHEDULE IS FURNISHED / ENCLOSED WITH THE OFFER, OR WRITE 'NO' UNDER CLOUMN '2', IF THE INFORMATION / SCHEDULE IS NOT FURNISHED / ENCLOSED WITH THE OFFER, OR WRITE 'NOT APPLICABLE (NA)' UNDER CLOUMN '2', IF THE INFORMATION / QUERY / SCHEDULE IS NOT RELEVANT TO THEM, AND RETURN THIS CHECKLIST AS THE PART OF THE OFFER DULY SIGNED BY THEM.

THE OFFERS WITHOUT THE CHECK LIST MAY NOT BE CONSIDERED FOR THE EVALUATION.

SN	Parameters	220 kV	YES/NO	33 kV	YES/NO	Remarks (If NO)
1	Type/class of Circuit Breaker	SF6	YES/NO	Vacuum/SF6	YES/NO	
2	Manufacturer's type designation					
3	Standard Applicable	IEC 62271 - 100	YES/NO	IEC 62271 - 100	YES/NO	
4	Rated Voltage (kV rms)	220	YES/NO	33	YES/NO	
5	Rated Current					
6	Under normal condition (A)	1250 A	YES/NO	630 A	YES/NO	
7	Max fault level (1 s)	31.5 kA	YES/NO	12.5 kA	YES/NO	
8	Phase to phase spacing	4500 mm	YES/NO	1500 mm	YES/NO	
9	Number of poles	3	YES/NO	3	YES/NO	
10	Whether All The 3 poles ganged electrically or mechanically	Electrically	YES/NO	Machanically	YES/NO	
11	Whether dead tank or live tank design	Live	YES/NO	Live	YES/NO	
12	No. of break per pole	1	YES/NO	1	YES/NO	
13	Line charging current breaking capability (A)	125	YES/NO	Bidder to fill		
14	Mechanical opening time	<42ms		<42ms	YES/NO	
15	Rated small inductive current Breaking capacity	250A		Bidder to fill		
16	Total break time	<60ms		<60ms	YES/NO	
17	Closing time	Up to 150ms	YES/NO	Up to 150ms	YES/NO	
18	First pole to clear factor	1.3	YES/NO	Bidder to fill		
19	Short time current rating (kA) for 1s	31.5	YES/NO	12.5	YES/NO	
20	Rated operating duty	O-0.3 Sec –CO -3 min –CO	YES/NO	O-0.3 Sec – CO -3 min – CO	YES/NO	

220/33kV Switchyard for Kishanganga (3x110MW) HEP for NHPC Limited

Technical Specification Doc.No. TB 329 316 008 Rev.00

220kV & 33kV Outdoor Circuit Breaker

SN	Parameters	220 kV	YES/NO	33 kV	YES/NO	Remarks (If NO)
21	Reclosing	Single and three phase auto reclosing	YES/NO	Three phase auto reclosing	YES/NO	
22	Seismic acceleration	0.36g Horizontal	YES/NO	0.36g Horizontal	YES/NO	
23	Dielectric withstand of complete Breaker					
a)	One minute dry & wet power frequency withstand voltage					
	i. Between live terminal and ground (kV rms)	506	YES/NO	77	YES/NO	
	ii. Between terminals with breaker contacts open (kV rms)	583	YES/NO	77	YES/NO	
b)	1.2/50- micro second impulse withstand test voltage					
	i. Between live terminals and ground (kVp)	±1155	YES/NO	±187	YES/NO	
	ii. Between terminals with breaker contacts open (kVp)	±1320	YES/NO	±187	YES/NO	
c)	Corona extinction voltage (kV rms)	156	YES/NO	N.A.		
d)	Maximum radio interference voltage for Frequency between 0.5 MHz and 2 MHz	1000 (max) at voltage 1566 kV rms.	YES/NO	-	YES/NO	
e)	Actual creepage distance					Bidder to fill
24	Operating Mechanism					
	a) Type of operating mechanism for					
	i. Closing	1) Spring	YES/NO	1) Spring	YES/NO	
		2) Pneumatic	YES/NO	2) Spring	YES/NO	
	ii. Opening	1) Spring	YES/NO	1) Spring	YES/NO	
		2) Pneumatic	YES/NO	2) Spring	YES/NO	
25	General					
a)	Whether OGA drawing enclosed		YES/NO		YES/NO	
b)	Filled in GTP furnished		YES/NO		YES/NO	
c)	Interpole cabling included in Scope alongwith required Glands, Lugs etc.		YES		YES	

220/33kV Switchyard for Kishanganga (3x110MW) HEP for NHPC Limited

Technical Specification Doc.No. TB 329 316 008 Rev.00

220kV & 33kV Outdoor Circuit Breaker

SN	Parameters	220 kV	YES/NO	33 kV	YES/NO	Remarks (If NO)
d)	All Type Test Reports as per IEC 62271 – 100 (Not older than 5 years from 22.01.2009) are available with bidder	Available and list is enclosed	Yes	Available and list is enclosed	YES	
e)	Type Test reports for higher insulation (As per clause no. 1.5 (a) of section-1)	Available and type test report is enclosed.	Yes	Available and type test report is enclosed.	Yes	
f)	Type test report with operation at low temperature with 10 mm Ice loading	Available and type test report is enclosed.	Yes	Available and report is enclosed.	Yes	
g)	Whether GI support structure included in Supply		YES		YES	
h)	Whether foundation bolts for breakers and cabinets included in scope of supply		YES		YES	
i)	Whether documentation schedule as per attached enclosure agreed by bidder.		YES		YES	
j)	No. of Aux. contacts per pole for owner's future use	10 NO + 10 NC	YES	10 NO + 10 NC	YES	
k)	Min clearance in Air (mm)					
	(i) Between Live Parts		YES/NO		YES/NO	
	(ii) Live Part to Earth		YES/NO		YES/NO	
	(iii) Live Part to ground with Support Structure / Stool		YES/NO		YES/NO	
l)	Control Cabinet –					
	Degree of Protection	IP 65 (Min.)	YES/NO	IP 65 (Min.)	YES/NO	
	Type Tested for IP 65 within last 5 years		YES/NO		YES/NO	
m)	Supervision of Erection, testing and commissioning included in scope		YES/NO		YES/NO	
n)	Heater considered for Control cabinet		YES/NO		YES/NO	
o)	Write up enclosed along with the offer explaining suitability of Circuit breaker design for higher altitude (1795m), low temperature (-12 Deg C) and ice loading		YES/NO		YES/NO	