

NORTH KARANPURA STPP (3 X 660MW)

EPC PACKAGE

VOLUME – IIB

**TECHNICAL SPECIFICATION
FOR**

CABLE TRAYS & ACCESSORIES

**SPECIFICATION NO : *PE-TS-405-507-E021*
REVISION : *01***



**BHARAT HEAVY ELECTRICALS LIMITED
POWER SECTOR
PROJECT ENGINEERING MANAGEMENT
NOIDA, UP (INDIA) – 201301**



**NORTH KARANPURA STPP (3 X 660MW)
EPC PACKAGE**

**TECHNICAL SPECIFICATION FOR
CABLE TRAYS & ACCESSORIES**

SPECIFICATION NO. PE-TS- 405-507-E021

VOLUME II B

SECTION ---

REVISION 01

DATE: 05.06.2015

SHEET 1 OF 1

CONTENTS

Sl. No.	DESCRIPTION	NO. OF SHEETS
1.0	INSTRUCTIONS TO BIDDERS	01
2.0	PREAMBLE	01
3.0	SECTION – 'A' (SCOPE OF ENQUIRY)	02
4.0	<i>SECTION – 'B' (PROJECT INFORMATION)</i>	08
5.0	SECTION – 'C' (SPECIFIC TECHNICAL REQUIREMENTS)	03
5.1	<i>ANNEXURE-I (BOQ CUM PRICE SCHEDULE)</i>	02
5.2	<i>ANNEXURE-II (LIST OF DRAWINGS /DOCUMENTS TO BE SUBMITTED BY SUCCESSFUL BIDDER)</i>	01
5.3	<i>ANNEXURE-III (VENDOR DRAWING/DOCUMENT SCHEDULE)</i>	01
5.4	<i>ANNEXURE- IV (NTPC QUALITY ASSURANCE PLAN)</i>	01
6.0	SECTION- 'D'	
6.1	STANDARD TECHNICAL SPECIFICATION	03
6.2	DATA SHEET -A	02
7.0	STANDARD QUALITY PLAN	01
8.0	TYPICAL DETAILS OF CABLE TRAYS & ACCESSORIES (DRAWING NO. PE-DG-405-507-E005)	11
	TOTAL NO. OF SHEETS (INCLUDING COVER SHEET & CONTENT SHEET)	= 39

IT IS CONFIRMED THAT OUR TECHNICAL OFFER COMPLIES WITH THE SPECIFICATION IN TOTAL & THAT THERE ARE NO TECHNICAL DEVIATIONS.

BIDDER'S STAMP & SIGNATURE



**NORTH KARANPURA STPP (3 X 660MW)
EPC PACKAGE**

**TECHNICAL SPECIFICATION FOR
CABLE TRAYS & ACCESSORIES**

SPECIFICATION NO. PE-TS-405-507-E021

VOLUME II B

SECTION ---

REVISION 01

DATE: 05.06.2015

SHEET 1

OF 1

INSTRUCTIONS TO BIDDERS FOR PREPARING TECHNICAL OFFER

1. Two signed and stamped copies of the following shall be furnished by all bidders as technical offer :
 - a. Unpriced Price Schedule (Annexure-I: BOQ, as enclosed with the specification).
 - b. A copy of this sheet ("Instructions to Bidders for Preparing Technical Offer").
 - c. A copy of previous sheet ("Contents").
 - d. Name & Address of galvaniser as per clause 3.3 of section C.
2. No other technical submittal such as copies of type test certificates, data sheets, write-up, drawing, technical literature, etc. is required during tender stage. Any such submission, even if made, shall not be considered as part of offer.
3. No comments/ additions/ deletions shall be made by the bidder on the signed & stamped copy of the specification. Any such changes made by the bidder shall not be considered.
4. Confirmations/ comments (if any) regarding delivery schedules shall be furnished as part of the commercial offer. Any reference in the technical offer / covering letter shall not be considered by BHEL.
5. Any comments/ clarifications on technical/ inspection requirements furnished as part of bidder's covering letter shall not be considered by BHEL, and bidder's offer shall be construed to be in conformance with the specification.
6. Any changes made by the bidder in the price schedule with respect to the item description/ quantities, notes etc. from those given in Annexure-I of specification [Bill Of Quantities] shall not be considered (i.e., technical description, quantities, notes etc. as per specification shall prevail).

BIDDER'S STAMP & SIGNATURE



**NORTH KARANPURA STPP (3 X 660MW)
EPC PACKAGE**

**TECHNICAL SPECIFICATION FOR
CABLE TRAYS & ACCESSORIES**

SPECIFICATION NO. PE-TS-405-507-E021

VOLUME II B

SECTION ---

REVISION 01

DATE: 05.06.2015

SHEET 1 OF 1

PREAMBLE

1.0 The tender document contains two (2) volumes. The bidder shall meet the requirements of all the two volumes.

1.1 **Volume-I (CONDITIONS OF CONTRACT)**

This consists of four parts as below:-

- Volume-IA : This part contains instructions to bidders for making bids to BHEL.
Volume-IB : This part contains general commercial conditions of the tender & includes provision that vendor is responsible for the quality of item supplied by their sub-vendors.
Volume-IC : This part contains special conditions of contract.
Volume-ID : This part contains commercial conditions for erection & commissioning site work, as applicable.

1.2 **Volume-II TECHNICAL SPECIFICATIONS**

Technical requirements are stipulated in Volume-II which comprises of:-

- Volume-IIA : General Technical Conditions
Volume-IIB : Technical Specification including Drawings, if any.

1.2.1 **Volume-IIB**

This volume is sub-divided into following sections:-

- Section-A : This section outlines the scope of enquiry.
Section-B : This section provides "Project Information".
Section-C : This section indicates technical requirements specific to the contract, not covered in Section-D.
Section-D : This section comprises of technical specifications of equipments complete with data sheet A.

Data Sheet - A specifies data and other requirements pertaining to the Equipment.

2.0 The requirements mentioned in Section-C / Data Sheets-A of section-D shall prevail and govern in case of conflict between the same and the corresponding requirements mentioned in the descriptive portion in Section-D.



NORTH KARANPURA STPP (3 X 660MW)
EPC PACKAGE

TECHNICAL SPECIFICATION FOR
CABLE TRAYS & ACCESSORIES

SPECIFICATION NO. PE-TS- 405-507-E021

VOLUME II B

SECTION A

REVISION 01

DATE: 05.06.2015

SHEET 1 OF 2

SECTION – A

SCOPE OF ENQUIRY



**NORTH KARANPURA STPP (3 X 660MW)
EPC PACKAGE**

**TECHNICAL SPECIFICATION FOR
CABLE TRAYS & ACCESSORIES**

SPECIFICATION NO. PE-TS- 405-507-E021

VOLUME II B

SECTION A

REVISION 01

DATE: 05.06.2015

SHEET 2 OF 2

SCOPE OF ENQUIRY

- 1.0 This specification covers the Design, Manufacture, Inspection and Testing at Manufacturer's works, proper packing and delivery to site of Cable Trays & Accessories as mentioned in different sections of this specification for NORTH KARANPURA STPP (3 X 660MW).
- 2.0 It is not the intent to specify herein all the details of design & manufacture. However, the equipment shall conform in all respects to high standards of design engineering and workmanship and shall be capable of performing in continuous commercial operation at site conditions.
- 3.0 The general terms and conditions, instructions to bidders and other attachment referred to elsewhere are hereby made part of the tender specification.
- 4.0 The bidder shall be responsible for and governed by all requirements stipulated hereinafter.
- 5.0 Bidder shall confirm total compliance to the specification without any deviations from technical/quality assurance requirements stipulated.
- 6.0 The documents shall be in English Language and MKS system of units.



NORTH KARANPURA STPP (3 X 660MW)
EPC PACKAGE

TECHNICAL SPECIFICATION FOR
CABLE TRAYS & ACCESSORIES

SPECIFICATION NO. PE-TS-405-507-E021

VOLUME NO. : II-B

SECTION : B

REV NO. : 01 DATE : 05.06.2015

SHEET : 1 OF 8

SECTION - B

PROJECT INFORMATION

1.00.00

BACKGROUND

North Karanpura Super Thermal Power Project (3x660 MW), a pit head coal based thermal power project, is located in Hazaribagh and Chatra districts of Jharkhand State. Basic inputs i.e. coal, water and land have already been tied up. The project is proposed for the States & Union Territories of Northern, Western and Eastern Regions and the State of Jharkhand.

The capacity of the project is 1980 MW comprising of three (3) units of 660 MW each.

1.01.00

Location and Approach

The power project is proposed to be located near Tandwa town in Chatra districts in the state of Jharkhand on Hazaribagh-Chatra State highway at a distance of about 50 kms from Hazaribagh city. The nearest commercial airport is Ranchi at a distance of 150 kms from project site. The nearest railhead Khalarai Railway Station on Ranchi-Garhwa section of Eastern Railways is about 40 kms from project site.

Major rail/road distances from the project site are as under:

<u>City</u>	<u>Distance Approx. (kms)</u>
Ranchi	: 150
Khalarai	: 40

The site is located near Tandwa town having latitude and longitude of about 23^o 50' N to 23^o 52' N and 84^o 59' E to 85^o 2' E respectively. The Vicinity Plan of the project is placed at **Annexure-I**.

Further to the information given in this sub-section, Bidders are also advised to visit the project site and collect data on local site conditions.

1.02.00

Land

About 2245 acres of land is being acquired for the project. About 1500 acres of land is under possession/legal possession and out of 1500 acres, about 890 acres of land is to be used for plant, ash dyke and initial enabling township. No additional land is envisaged to be acquired in plant area. About 15 acres of land is envisaged to be acquired in Hazaribagh city for Township.

Commissioner, Chatra vide dated 25.05.1999 and 14.06.2000 has given in-principle clearance for NKSTPP.

1.03.00

Water

Make up water available for this project would be about 22 cusec and will be arranged by constructing a dam/reservoir across river Garhi.

1.04.00

Fuel (Coal)

1.04.01

Coal Requirement, Availability and Linkage

Coal requirement for the project is estimated as 10.6 Million Tonne/Annum (MTPA), considering a GCV of 3800 kcal/kg. Ministry of Coal vide letter dated 21.10.99 accorded in-principle coal linkage of 10.00 MTPA subject to ratification by Standing Linkage Committee-Long Term (SLC (LT)), of MOC. SLC (LT) in its meeting held on 15.12.2000 firmed up the coal linkage of 10.24 MTPA for the project. Subsequently, the coal linkage was withdrawn by SLC (LT) in its meeting held on 22/23.10.08.

CLAUSE NO.	PROJECT INFORMATION		
1.04.02	<p>Cabinet Committee on Investment (GOI) in its meeting on 20.02.13 decided in-principle to restore the original coal linkage granted to NKSTPP (i.e. from Magadh Coal Block) with the stipulation that the coal supply will commence during the 13th Five Year Plan. MOC vide letter dated 09.05.2013 restored the coal linkage with the stipulation that the coal supply will commence during the 13th five year plan.</p>		
1.04.02	<p>Coal Transportation</p> <p>Coal from Magadh block of North Karanpura Coalfields is proposed to be transported to the project site through conveyor belt system. One external coal handling plant and one internal coal handling plant are envisaged.</p>		
1.05.00	<p>Meteorological Data</p> <p>Important meteorological data from nearest observatory at Hazaribag is placed at Annexure-II.</p>		
1.06.00	<p>Plant Water Scheme</p> <p>The Plant water scheme is described below.</p>		
1.06.01	<p>Condenser Cooling System</p> <p>It is proposed to adopt Air Cooled Condenser for the project.</p>		
1.06.02	<p>Equipment Cooling Water (ECW) System (Unit Auxiliaries)</p> <p>All plant auxiliaries shall be cooled by De-mineralized water (DM) in a closed circuit. The primary circuit DM water shall be cooled through heat exchangers by auxiliary cooling water system. The hot secondary circuit cooling water shall be cooled in the cooling towers and shall be returned back to the system.</p>		
1.06.03	<p>Ash Water System</p> <p>It is proposed to have HCSD (High concentration Slurry Disposal) system for combined fly ash and bottom ash. No recirculation of ash water from ash disposal area is envisaged.</p>		
1.06.04	<p>Other Miscellaneous Water Systems</p> <p>(a) Raw water shall be used for meeting the Fly ash and bottom ash system requirement etc.</p> <p>(b) The service water shall be taken from clarified water tank of Pretreatment plant. Service water (wash water) collected from various areas shall be treated using oil water separators, tube settlers, coal settling pits etc. as per requirement and treated water from liquid effluent treatment plant shall be recycled back to the service water system for re-use.</p> <p>(c) The drinking water requirement of the plant shall be provided from water treatment plant.</p>		
<p>NORTH KARANPURA STPP (3 X 660 MW) EPC PACKAGE</p>	<p>TECHNICAL SPECIFICATION SECTION – VI, PART-A BID DOC. NO.:CS-4410-001-2</p>	<p>SUB-SECTION-IB PROJECT INFORMATION</p>	<p>PAGE 2 OF 10</p>



CLAUSE NO.	PROJECT INFORMATION				
<p>1.07.00</p> <p>1.08.00</p>	<p>(d) Steam Cycle make-up water, makeup to the primary circuit of ECW (unit auxiliaries) system, boiler fill water and makeup to the hydrogen generation plant shall be provided from Demineralising plant.</p> <p>(e) The quality of Raw water is enclosed with this sub-section as Annexure-III.</p> <p>Criteria for Earthquake Resistant Design of Structures and Equipment</p> <p>All power plant structures and equipment, including plant auxiliary structures and equipment shall be designed for seismic forces as given in the Part - B of this section.</p> <p>Criteria for Wind Resistant Design of Structures and Equipment</p> <p>All structures and equipment of the power plant, including plant auxiliary structures and equipment, shall be designed for wind forces as given as given in Part B of this section.</p>	<p>NORTH KARANPURA STPP (3 X 660 MW) EPC PACKAGE</p>	<p>TECHNICAL SPECIFICATION SECTION – VI, PART-A BID DOC. NO.:CS-4410-001-2</p>	<p>SUB-SECTION-IB PROJECT INFORMATION</p>	<p>PAGE 3 OF 10</p>



VICINITY PLAN

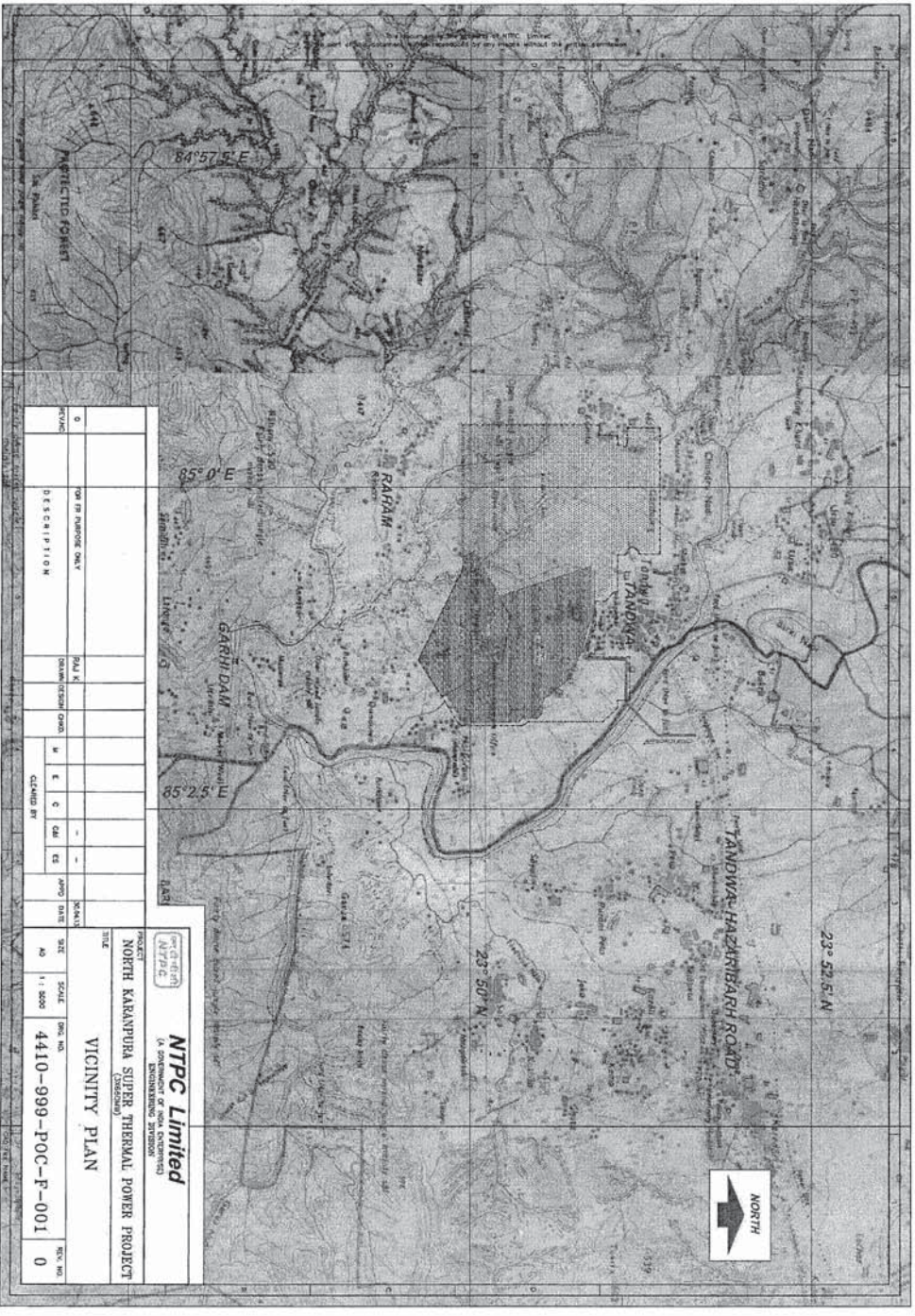

 NTPC Limited <small>(A GOVERNMENT OF INDIA ENTERPRISE)</small> <small>ENGINEERING DIVISION</small>		PROJECT NORTH KARANPURA SUPER THERMAL POWER PROJECT <small>(Phase-III)</small>		TITLE VICINITY PLAN	
SCALE	DATE	NO.	REV.	DATE	NO.
1:5000	4410-999-POC-F-001	0			
FOR FE NUMBER ONLY DRAWING CHG. NO.		H. E. C. S. I.		CLASSIFIED BY	
DESCRIPTION		DATE		SCALE	



CLIMATOLOGICAL TABLE

CLIMATOLOGICAL TABLE

STATION : Hazaribagh

LAT 23°59' N LONG 85°22' E

HEIGHT 800/2645.5 L

811 METRES

1951 से 1980 तक के दिनों पर आधारित
BASED ON OBSERVATIONS FROM 1951 TO 1980

MONTH	STATION PRESSURE	WET BULB			MEAN			AIR TEMPERATURE			EXTREMES			HUMIDITY			CLOUD AMOUNT			RAINFALL			MEDIAN WIND SPEED		
		WET BULB	WET BULB	WET BULB	DAILY MAX	DAILY MIN	DAILY MEAN	HIGHEST IN THE MONTH	LOWEST IN THE MONTH	HIGHEST AND LOWEST	DATE AND YEAR	DATE AND YEAR	DATE AND YEAR	RELATIVE HUMIDITY	VAPOUR PRESSURE	RELATIVE HUMIDITY	ALL CLOUDS	LOW CLOUDS	NO. OF DAYS	TOTAL MONTHLY	TOTAL YEARLY	HIGHEST IN MONTH		FALL IN MONTH	DATE AND YEAR
	hPa	°C	°C	°C	°C	°C	°C	°C	°C	°C	°C	°C	°C	%	hPa	%	%	%	mm	mm	mm	mm	mm	mm	mm
JAN	947.6	14.7	10.9	22.6	26.7	9.3	30.6	3.1	0.9	07	1960	62	10.4	1.4	0.5	23.5	1.7	113.0	0.0	66.1	06	1945	6.2		
FEB	945.7	17.6	12.3	25.7	30.5	6.9	33.9	1.2	1.7	08	1974	55	10.3	1.3	0.4	18.2	1.4	117.3	0.0	83.5	27	1927	7.3		
MAR	944.0	23.4	15.0	30.6	35.9	11.4	38.9	1.7	6.7	04	1998	39	10.8	1.4	0.6	16.4	1.7	156.3	0.0	44.8	20	1950	7.9		
APR	941.0	28.6	18.2	35.7	39.3	15.4	41.7	2.2	10.9	01	1958	28	13.3	1.9	0.3	17.0	1.4	181.3	0.0	60.5	22	1925	9.6		
MAY	937.0	30.7	21.1	37.8	41.5	19.3	43.9	1.6	15.6	22	1977	19	18.1	2.5	0.2	43.4	2.9	187.2	0.0	84.1	27	1927	9.1		
JUN	933.4	28.4	23.3	34.1	40.1	21.0	48.8	1.4	18.3	02	1975	32	16.7	2.9	0.7	177.1	9.2	774.5	0.5	248.4	24	1927	8.7		
JUL	932.1	25.6	23.8	29.5	35.2	21.4	39.6	0.9	19.3	18	1975	86	28.2	6.5	3.0	310.0	18.2	892.2	99.3	221.7	08	1924	7.9		
AUG	930.5	26.8	24.1	29.1	31.5	21.9	34.2	0.3	20.0	20	1987	89	28.3	6.4	3.6	320.1	15.2	708.1	83.9	188.1	17	1924	7.9		
SEP	928.2	25.1	23.1	29.0	31.5	20.4	33.3	0.2	17.8	29	1990	84	28.7	6.4	3.5	263.0	11.8	530.9	40.7	167.1	25	1953	7.3		
OCT	926.6	23.9	20.4	28.5	31.3	14.3	34.0	0.4	9.7	12	1972	85	28.6	5.1	2.9	80.6	4.1	378.8	0.0	143.4	24	1924	5.2		
NOV	924.0	20.2	15.5	25.8	28.3	9.0	31.7	0.1	4.4	35	1979	80	14.3	1.2	0.4	5.8	0.4	180.0	0.0	95.0	08	1924	4.8		
DEC	921.1	15.7	11.8	23.1	28.2	5.1	29.4	0.0	0.5	24	1951	52	11.1	1.1	0.2	5.2	0.4	185.5	0.0	39.4	15	1924	5.0		
ANNUAL MEAN	941.1	23.3	18.3	29.3	34.9	18.1	41.9	3.8	46.6			63	18.2	3.0	1.3	1277.9	67.2	2146.0	738.6	249.2			7.8		
TOTAL OF 31 YEARS	928.0	25.9	19.1									55	17.7	3.3	1.5			1893		1568				8.3	
NUMBER OF YEARS	26	27	27	27	27	26	27	26	27	26	27	26	27	26	27	26	27	26	27	26	27	26	27	26	27

CLAUSE NO.	PROJECT INFORMATION			
1.00.00	General Requirements			
1.01.00	For the purpose of design of equipment/systems, an ambient temperature of 50 deg. Centigrade and relative humidity of 95% shall be considered. The equipment shall operate in a highly polluted environment. However, for equipment in air conditioned areas, design ambient temperature shall be 35 deg.C, if 2x100% air conditioning system is provided.			
1.02.00	All equipments shall be suitable for rated frequency of 50Hz with a variation of +3% & -5%, and 10% combined variation of voltage and frequency unless specifically brought out in the specification. The step-up voltage level for the project shall be 400 KV. The turbo generator unit will be connected to its own step-up transformers for feeding power into the EHV grid. The overall system shall be designed considering voltage variation of +/- 5% and fault level of 50kA for 400KV and 40kA for 220 KV system. Under black start condition the minimum fault level of 1000 MVA shall be considered at 400KV voltage level and voltage variation at 400kV may be considered as +/-10% till system stabilization.			
1.03.00	Contractor shall provide fully compatible electrical system, equipments, accessories and services for the entire station/plant in his scope as well as those specifically required by the Employer.			
1.04.00	All the equipment, material and systems shall, in general, conform to the latest edition of relevant National and International Codes & Standards, especially the Indian Statutory Regulations.			
1.05.00	The auxiliary AC voltage supply arrangement shall have 33 kV, 11 kV, 3.3KV and 415V systems. It shall be designed to limit voltage variations as given below under worst operating condition:			
	a) 33KV/11KV/3.3KV (MV)	+/- 6%		
	b) 415 V/240 V	+/- 10%		
	c) 220V DC	-15% to +10% However the nominal continuous DC power supply shall be 240V.		
1.06.00	The voltage level for motors shall be as follows:			
	a) Upto 0.2 KW	: Single phase 240V AC / 3 phase 415V AC		
	b) Above 0.2 KW and upto 200 KW	: 3 phase, 415V AC		
	c) Above 200 KW and upto 1500 KW	: 3 phase, 3.3 kV AC		
	d) Above 1500 KW	: 11 kV		
	The bidder may adopt 415V/3.3 KV for the drives rated in the range of 160-210 KW.			
	For CHP conveyor motor's rating above 160 kW, 3.3 KV, three phase AC supply is to be used.			
	The voltage rating of the drives indicated above is for basic guideline. Minor variations in above can be accepted on case to case basis based on techno-economic considerations of the various sub-systems.			
	Voltage rating for special purpose motors viz, VFD and screw compressors, shall be as per manufacturer's standard. All the motors ratings on Stacker/ reclaimers shall be 415V ac supply only.			
<p align="center">NORTH KARANPURA STPP (3 X 660 MW) EPC PACKAGE</p>	<p align="center">TECHNICAL SPECIFICATIONS SECTION – VI, PART-B</p>	<p align="center">SUB-SECTION-B0 GENERAL ELECTRICAL SPECIFICATION</p>	<p align="center">PAGE 1 OF 11</p>	

CLAUSE NO.	PROJECT INFORMATION			
1.07.00	<p>The preferred AC control supply voltage shall be 110V for all 415 V non breaker controlled feeders. Control supply voltages other than above may be offered by bidder based on the bidder's standard proven practice.</p>			
1.08.00	<p>The designed fault levels for 11 KV & 3.3 KV systems shall be restricted to 40 kA rms for 1 second and 50 kA rms for 1 second for 415 V systems. The 33 KV system equipments shall have a minimum short circuit fault withstand rating of 12.5 kA for 1 second.</p>			
1.09.00	<p>The nominal voltage of main DC system shall be 220V. DC batteries shall be designed for continuous float operation with trickle charge, hence all the associated components like batteries, battery chargers, DC motors, relays, contactors, timers etc shall be suitable for continuous operation at the maximum continuous battery float voltage including suitable temperature correction factors. The operational limits of variation of DC voltage is (+)10 % to (-)15%.</p> <p>In addition, the bidder may propose 110V, 48V or 24V systems as per requirements of control and instrumentation of his equipment and design.</p>			
1.10.00	<p>The Contractor shall furnish calculations of maximum loading and fault levels under the most onerous conditions for the various equipment/systems as defined else where in the specification to prove adequacy of their parameters. In case any equipment or system is found to be inadequate, it shall be changed/ modified without any additional liability to the Employer.</p>			
<p align="center">NORTH KARANPURA STPP (3 X 660 MW) EPC PACKAGE</p>	<p align="center">TECHNICAL SPECIFICATIONS SECTION – VI, PART-B</p>	<p align="center">SUB-SECTION-B0 GENERAL ELECTRICAL SPECIFICATION</p>	<p align="center">PAGE 2 OF 11</p>	



NORTH KARANPURA STPP (3 X
660MW), EPC PACKAGE

TECHNICAL SPECIFICATION FOR
CABLE TRAYS & ACCESSORIES

SPECIFICATION NO. PE-TS-405-507-E021

VOLUME II B

SECTION C

REVISION 01

DATE: 05.06.2015

SHEET 1 OF 3

SECTION -C

SPECIFIC TECHNICAL REQUIREMENTS

	<p style="text-align: center;">NORTH KARANPURA STPP (3 X 660MW), EPC PACKAGE</p> <p style="text-align: center;">TECHNICAL SPECIFICATION FOR CABLE TRAYS & ACCESSORIES</p>	SPECIFICATION NO. PE-TS-405-507-E021	
		VOLUME II B	
		SECTION C	
		REVISION 01	DATE: 05.06.2015
		SHEET 2 OF 3	

1.0 SCOPE OF ENQUIRY

- 1.1 This enquiry covers the supply of **Cable Trays & Accessories** conforming to this specification.
- 1.2 General technical requirements of the Cable Trays & Accessories are indicated in Section-D. Project specific technical/ quality requirements / changes are listed in Section-C.
- 1.3 The stipulations of Section-C, followed by those of Data Sheet-A shall prevail in case of any conflict between the stipulations of Section-C, Data Sheet - A & Section-D.

2.0 BILL OF QUANTITIES:

- 2.1 Quantity requirements shall be as per **Annexure-I (Bill of Quantities (BOQ))** enclosed.
- 2.2 Number of coupler plates, washers, nuts & bolts to be supplied by vendor shall be as per **Data Sheet-A**.

3.0 SPECIFIC REQUIREMENTS:

3.1 Technical:

<i>S. No.</i>	<i>Reference clause No. of Section D (if any)</i>	<i>Specific Requirement/ Change</i>

3.2 Quality/ Inspection:

<i>S. No.</i>	<i>Reference clause No. of Section D (if any)</i>	<i>Specific Requirement/ Change</i>
1	4.4	One piece each of 2.5m length of cable tray of 300mm & above shall be taken as sample from each offered lot. It shall be supported at both end & loaded with uniform load of 76 kg/meter along the length of cable tray. The maximum deflection at the mid-span of each size shall not exceed 7mm.
2	4.3	Additional requirement in cl. No 4.3: <u>Routine Tests</u> a) Routine tests as per specification and applicable standards shall be carried out on all equipment/items covered in the specification. b) Physical & dimensional check on all equipment as

	NORTH KARANPURA STPP (3 X 660MW), EPC PACKAGE TECHNICAL SPECIFICATION FOR CABLE TRAYS & ACCESSORIES	SPECIFICATION NO. PE-TS-405-507-E021	
		VOLUME II B	
		SECTION C	
		REVISION 01	DATE: 05.06.2015
		SHEET 3 OF 3	

		per approved drawings/standards. c) HV/IR as applicable. d) Check/measurement of thickness of paint/zinc coating/nickel-chrome plating as per specification & applicable standard. <u>Acceptance Tests</u> a) Galvanising Tests as per applicable standards b) Welding checks c) Deflection tests on cable trays
3	BHEL Standard Quality plan PED-507-00-Q-005/04	NTPC standard quality plan (0000-999-QOE-S-021) to be considered.

NTPC quality assurance plan has been attached as ANNEXURE- IV. Bidder to furnish the quality Plan accordingly.

- 3.3 Bidder has to submit a document indicating the galvaniser name & works address at the bidding stage as per PQR for BHEL/NTPC review

	TECHNICAL SPECIFICATION FOR CABLE TRAY & ACCESSORIES	SPECIFICATION NO. PE-TS-405-507-E021	
		VOLUME IIB	
		SECTION ----	
		REVISION 01	DATE:- 05.06.2015
		SHEET 1 of 2	

ANNEXURE - I

(BOQ-CUM-PRICE SCHEDULE FOR CABLE TRAYS & ACCESSORIES)

Sr. No.	ITEM CODE	ITEM DESCRIPTION	UNIT	Ordered quantity	LOT-1 QTY.	UNIT PRICE (EX WORKS) Rs.	TOTAL PRICE (EX-WORKS) Rs.
1.0		HOT DIP GALVANISED LADDER TYPE CABLE TRAY COMPLETE WITH COUPLER PLATES, FASTENERS, CLAMPS AND FIXING HARDWARES ETC.					
a)	507-21101-A	CABLE TRAY 2 MM THICK- LADDER TYPE 150W	MTR	4500	3150		
b)	507-21102-A	CABLE TRAY 2 MM THICK- LADDER TYPE 300W	MTR	31000	21700		
c)	507-21104-A	CABLE TRAY 2 MM THICK- LADDER TYPE 600W	MTR	82500	57750		
2.0		HOT DIP GALVANISED PERFORATED TYPE CABLE TRAY COMPLETE WITH COUPLER PLATES, FASTENERS, CLAMPS AND FIXING HARDWARES ETC.					
a)	507-21109-A	CABLE TRAY 2 MM THICK- PERFORATED TYPE 150W	MTR	2000	1400		
b)	507-21110-A	CABLE TRAY 2 MM THICK- PERFORATED TYPE 300W	MTR	4500	3150		
c)	507-21112-A	CABLE TRAY 2 MM THICK- PERFORATED TYPE 600W	MTR	27000	18900		
3.0		CABLE TROUGHS					
a)	507-21199-A	CABLE TROUGH 2 MM THICK 50MM W	MTR	500	350		
b)	507-21200-A	CABLE TROUGH 2 MM THICK 75MM W	MTR	500	350		
		HOT DIP GALVANISED CABLE TRAY ACCESSORIES					
4.1		LADDER TYPE HORIZONTAL 90 DEG. BEND-600mm RADIUS					
a)	507-21117-A	LAD HOR 90DEG BEND 2 MM THICK 600 RAD 300W	NOS	120	84		
b)	507-21119-A	LAD HOR 90DEG BEND 2 MM THICK 600 RAD 600W	NOS	650	455		
4.2		LADDER TYPE VERTICAL 90 DEG. BEND-600mm RADIUS (INSIDE)					
a)	507-21123-A	LAD VER 90DEG BEND 2 MM THICK 600 RAD-INSIDE 300W	NOS	85	60		
b)	507-21125-A	LAD VER 90DEG BEND 2 MM THICK 600 RAD-INSIDE 600W	NOS	185	130		
4.3		LADDER TYPE VERTICAL 90 DEG. BEND-600mm RADIUS (OUTSIDE)					
a)	507-21129-A	LAD VER 90DEG BEND 2 MM THICK 600 RAD-OUTSIDE 300W	NOS	115	81		
b)	507-21131-A	LAD VER 90DEG BEND 2 MM THICK 600 RAD-OUTSIDE 600W	NOS	270	189		
4.4		LADDER TYPE TEES-600mm RADIUS					
a)	507-21135-A	LAD TEES 600MM RADIUS 2 MM THICK 300W	NOS	100	70		
b)	507-21137-A	LAD TEES 600MM RADIUS 2 MM THICK 600W	NOS	1150	805		
4.5		LADDER TYPE CROSS-600mm RADIUS					
a)	507-21141-A	LAD CROSS 600 RAD 2 MM THICK 300W	NOS	10	7		
b)	507-21143-A	LAD CROSS 600 RAD 2 MM THICK 600W	NOS	70	49		
4.6		LADDER TYPE REDUCERS					
a)	507-21148-A	LAD REDUCER (50% LHS/RHS) 2 MM THICK 600-300W	NOS	45	22		
4.7		PERFORATED TYPE HORIZONTAL 90 DEG. BEND-600mm RADIUS					
a)	507-21153-A	PER HOR 90DEG BEND 2 MM THICK 600 RAD 300W	NOS	70	49		
b)	507-21155-A	PER HOR 90DEG BEND 2 MM THICK 600 RAD 600W	NOS	510	357		

	TECHNICAL SPECIFICATION FOR CABLE TRAY & ACCESSORIES	SPECIFICATION NO. PE-TS-405-507-E021	
		VOLUME IIB	
		SECTION ----	
		REVISION 01	DATE:- 05.06.2015
		SHEET 1 of 2	

Sr. No.	ITEM CODE	ITEM DESCRIPTION	UNIT			UNIT PRICE (EX WORKS) Rs.	TOTAL PRICE (EX-WORKS) Rs.
4.8		PERFORATED TYPE VERTICAL 90 DEG. BEND- 600mm RADIUS (INSIDE)					
a)	507-21159-A	PER VER 90DEG BEND 2 MM THICK 600 RAD-INSIDE 300W	NOS	10	7		
b)	507-21161-A	PER VER 90DEG BEND 2 MM THICK 600 RAD-INSIDE 600W	NOS	45	32		
4.9		PERFORATED TYPE VERTICAL 90 DEG. BEND- 600mm RADIUS (OUTSIDE)					
a)	507-21165-A	PER VER 90DEG BEND 2 MM THICK 600 RAD-OUTSIDE 300W	NOS	120	84		
b)	507-21167-A	PER VER 90DEG BEND 2 MM THICK 600 RAD-OUTSIDE 600W	NOS	75	53		
4.10		PERFORATED TYPE TEES-600mm RADIUS					
a)	507-21171-A	PER TEES 600MM RADIUS 2 MM THICK 300W	NOS	32	22		
b)	507-21173-A	PER TEES 600MM RADIUS 2 MM THICK 600W	NOS	620	434		
4.11		PERFORATED TYPE CROSS-600mm RADIUS					
a)	507-21177-A	PER CROSS 600 RAD 2 MM THICK 300W	NOS	10	7		
b)	507-21179-A	PER CROSS 600 RAD 2 MM THICK 600W	NOS	15	11		
4.12		PERFORATED TYPE REDUCERS					
a)	507-21184-A	PER REDUCER (50% LHS/RHS) 2MM THICK 600-300W	NOS	35	25		
5.0		HPT DIP GALVANISED CABLE TRAY COVER COMPLETE WITH FORMED CHANNEL, PIPE, GI FLAT, BOLTS WITH NUTS & WASHERS & FIXING HARDWARES ETC. (1.6mm THICK GALVANISED MS SHEET)					
a)	507-21189-A	COVER 1.6MM THK-NON PERFORATED GALV MS 150W	MTR	500	0		
b)	507-21190-A	COVER 1.6MM THK-NON PERFORATED GALV MS 300W	MTR	500	0		
c)	507-21192-A	COVER 1.6MM THK-NON PERFORATED GALV MS 600W	MTS	500	0		

NOTES:

- The quantities will be released for manufacture in more than one lot. Lot-I quantities, which are indicated above, shall be released for manufacture along with LOI.
- Manufacturing of Lot-I quantities shall be done after the approval of technical and quality documentation, and supply of same shall be completed within four months of date of approval of documents.
- Subsequent lots shall be cleared for manufacture based on progress of engineering and site requirements. A lead-time of three months shall be given for completion of supply of each lot from the date of clearance of the quantities.
- The total quantity variation shall be limited from -30 % to +30 % of the total contract value derived on the basis of the Order Quantities.
- Raw materials: - Steel shall be procured from SAIL / TISCO / ISPATIND/JINDAL/ ESSAR/BHUSHAN STEEL/RINL or authorised re-rollers of SAIL.
- The number of coupler plates, washers, bolts & nuts shall be as per Data Sheet- A attached with the specification.

	NORTH KARANPURA STPP (3 X 660MW), EPC PACKAGE TECHNICAL SPECIFICATION FOR CABLE TRAYS & ACCESSORIES	SPECIFICATION NO. PE-TS-405-507-E021	
		VOLUME II B	
		SECTION ----	
		REVISION 01	DATE: 05.06.2015
		SHEET 1	OF 1

ANNEXURE – II

**LIST OF DRAWINGS / DOCUMENTS
(REQUIRED TO BE FURNISHED BY SUCCESSFUL BIDDER AFTER AWARD OF CONTRACT)**

Sl. No.	Drawings/Document Description	Drawings / Document Number	Submission Schedule
1.	Technical Data Sheet for Cable Trays & Accessories	PE-V0-405-507-E011	Within one week of award of contract
2.	GA drawings of Cable Trays & Accessories	PE-V0-405-507-E012	Within one week of award of contract
3.	Quality Plan for Cable Trays & Accessories	PE-V0-405-507-E902	Within one week of award of contract

Note:-

It may please be noted that successful bidder is not to make any fresh submittals at contract stage w.r.t. above mentioned drawings/documents. Data Sheet-A, Standard Quality Plan/Reference Quality Plan agreed with end customer & Typical details of Cable trays & Accessories as enclosed in the technical specification are to be appended with cover sheet bearing drawing/document number & description as stated above. The signed & stamped for the same shall be submitted by successful bidder to BHEL within one week of award of contract without making any changes in the contents of the drawing/document.

CLAUSE NO.

GENERAL TECHNICAL REQUIREMENTS Annexure-III



S.No	Description of Drgs/Docs	No of Prints	No of ROMs/DVDs/Portable Hard Disk	CD
1	Drawings, Data sheets, Design calculations, Purchase specifications and other documents			
	First submission and submission with major changes			
	▪ Layout (A0&A1 sizes)	4	-	
	▪ Other Drawings/Documents (A0&A1 sizes)	2	-	
	▪ P&ID (All sizes)	4	-	
	a) Final drawings/documents (Directly to site)	6	2	
	b) "As Built" Drawing/Documents (Directly to site)	6	2	
	c) Analysis reports of Equipments / piping /structures components/system employing software packages as detailed in the specifications.	2	2	
2	Erection Manual (Directly to site)	4 sets	2	
3	Operation & Maintenance manual	1 set	--	
	i) First Submission	1 set	--	
	ii) Final Submission (Directly to site)	4 sets	2	
4	Plant Hand Book			
	i) First Submission	1	1	
5	Commissioning and Performance Test Procedure manual	1 set	--	
	i) First Submission	1 set	--	
	ii) Final Submission (Directly to site)	4 sets	2	

NORTH KARANPURA STPP
(3X660 MW)
EPC PACKAGE

TECHNICAL SPECIFICATION
SECTION - VI, PART-C
BID DOC.NO.:CS-4410-001-2

GENERAL TECHNICAL
REQUIREMENTS
Annexure-VI

PAGE
83 OF 100

098

CLAUSE NO.	QUALITY ASSURANCE													
														
CABLING, EARTHING, LIGHTNING PROTECTION														
ATTRIBUTES / CHARACTERISTICS ITEMS/COMPONENTS / SUB SYSTEMS	Dimension	Paint shade, paint thickness, adhesion	Pre-treatment of sheet	IP protection	Proof load*	Surface finish	Deflection test*	HV & IR	Galvanise Test (If Applicable)	Functional	Bought out items/Bill of material	Routine tests as per relevant standard & specification	Acceptance tests as per relevant standard & specification	Constructional feature as per NTPC
	Wall Mounted-Lighting Panel (IS-513, IS:5, IS:2629, 2633, 6745)	Y	Y	Y	Y		Y		Y	Y	Y	Y	Y	Y
Switch box/junction box/ Receptacles Panel (IS-513, IS:5, IS:2629, 2633, 6745)	Y	Y	Y	Y		Y		Y	Y	Y	Y	Y	Y	Y
Cable glands(BS-6121)	Y											Y		
Cable lug(IS-8309)	Y											Y		
Lighting wire(IS-694)	Y											Y		
Flexible conduits	Y											Y		Y
Conduits(Galvanise & Epoxy) IS-9537 & IS-2629,2633 ,6745	Y		Y								Y	Y		Y
RCC Hume Pipe (IS-458)												Y		
Cable termination & straight through joint (VDE-0278)	Y											Y		Y
Cable Trays, Flexible supports system & accessories IS-513, 2629,2633,6745	Y		Y		Y	Y	Y	Y	Y	Y		Y	Y	Y
Trefoil clamp	Y													Y
GI flats for earthing & lighting protection (IS 2062, 2629, 6745,2633)	Y		Y						Y			Y		Y
GI wire (IS-280)	Y											Y		
Fire Sealing System (BS -476)												Y	Y	Y
<p>.Note:1.This is an indicative list of tests /checks. The manufacturer is to furnish a detailed Quality Plan indicating the practice and procedure along with relevant supporting documents.</p> <p>2.* Deflection Test on cable trays and Proof Load test on cable trays support system will be as per details given in the NTPC technical specification & approved MQP. The above acceptance tests shall be done only on one sample from each size of offered lot.</p> <p>3. Make of all items will be subject to NTPC approval.</p>														
NORTH KARANPURA STPP (3 X 660 MW) EPC PACKAGE	TECHNICAL SPECIFICATION SECTION-VI, PART-B BID DOC NO.:CS-4410-001-2	SUB-SECTION-E-32 CABLING, EARTHING, LIGHTNING AND PROT.	Page 1 of 1											



**STANDARD TECHNICAL SPECIFICATION
FOR CABLE TRAYS & ACCESSORIES**

SPECIFICATION NO. PE-TS-999-507-E021	
VOLUME II B	
SECTION D	
REVISION 1	DATE: 05.06.2015
SHEET 1 OF 3	

SECTION-D

STANDARD TECHNICAL SPECIFICATION



**STANDARD TECHNICAL SPECIFICATION
FOR CABLE TRAYS & ACCESSORIES**

SPECIFICATION NO. PE-TS-999-507-E021

VOLUME II B

SECTION D

REVISION 1

DATE: 05.06.2015

SHEET 2 OF 3

1.0 SCOPE OF ENQUIRY

1.1 This specification covers the design, manufacture, assembly, testing and inspection at vendor's/sub vendor's works, packing and despatch to site of **CABLE TRAYS & ACCESSORIES** as described in various sections of this specification.

2.0 CODES & STANDARDS

2.1 The material, constructional features and various processes involved in manufacture shall comply with latest revision of relevant Indian Standards.

2.2 The design, material, construction, manufacture, inspection, testing and performance of Cable Trays & Accessories shall conform to the latest revision of relevant standards and codes of practices mentioned in Data Sheet - A.

2.3 In case of conflict between the applicable reference standard and this specification, this specification shall govern.

3.0 DESIGN REQUIREMENTS AND CONSTRUCTIONAL FEATURES

3.1 All items listed in the BOQ –Cum-Price Schedule for Cable Trays & Accessories (Annexure - I of the specification) shall be manufactured as per Datasheet-A and project drawings enclosed with this specification. Minor fabrication detail changes which do not affect the material / dimensional aspect of the equipment, shall be to BHEL / owner's approval without any commercial implications.

3.2 Cable Trays & Accessories, Tray Covers and Fittings:

3.2.1 Cable trays & accessories shall be of two types, namely ladder type and perforated type as specified in Data Sheet A and drawings enclosed with this specification.

3.2.2 Coupler plates shall be provided for connecting tray ends to other straight trays, horizontal elbows, vertical elbows, tees, cross, reducers etc.

3.2.3 Necessary fasteners shall be provided along with each length of cable tray as specified in drawings enclosed. The number of coupler plates, washers, nuts & bolts to be supplied shall be as per Data Sheet – A.

3.2.4 The width of the tray covers (where provided) shall be suitable for the width of trays. Suitable bolting arrangement shall be supplied for attaching the cover to the cable trays, elbows, reducers, tees etc. as per the drawing enclosed.

3.2.5 All welded joints shall be smooth enough to provide a good appearance and shall not cause any injury to working personnel or any damage to the cable laid directly on it. All welding work shall be done by skilled personnel.

4.0 QUALITY / INSPECTION:

4.1 BHEL's Standard QP (QP NO. PED-507-00-Q-005/04) is enclosed for reference. However, at contract stage, the successful bidder shall submit the QP for BHEL/ ultimate customer's approval. In case bidder has reference QP agreed with ultimate customer, same can be submitted for specific project after award of contract for BHEL/ ultimate customer's approval. There shall be no commercial implication to BHEL on account of QP approval.

4.2 All materials shall be procured, manufactured, inspected and tested by vendor/ sub-vendor as per approved quality plan.



**STANDARD TECHNICAL SPECIFICATION
FOR CABLE TRAYS & ACCESSORIES**

SPECIFICATION NO. PE-TS-999-507-E021

VOLUME II B

SECTION D

REVISION 1

DATE: 05.06.2015

SHEET 3 OF 3

4.3 The supplier shall perform all tests necessary to ensure that the material and workmanship conform to the relevant standards and comply with the requirements of the specification. Charges for all these tests for all the equipments & components shall be deemed to be included in the bid price.

4.4 Load Test:-

A 2.5 meter straight section of each type of cable tray of width 600mm shall be simply supported at the two ends. A uniformly distributed load of 100 kg per meter shall be applied along the length of tray. The maximum deflection at mid span shall not exceed 7 mm.

5.0 PACKING

The material shall be packed to ensure protection against damage during transit, storage for prolonged periods and handling.

6.0 DELIVERY

The delivery shall be as per NIT (Notice Inviting Tender).

7.0 DOCUMENTATION

7.1 Documents to be submitted by the bidder along with the bid.

- a) A copy of sheet "Contents" with bidder's signature & company stamp
- b) A copy of sheet "Instructions to bidders for preparing Technical offer" with bidder's signature & company stamp.
- c) Unpriced copy of "Annexure-I (BOQ – Cum- Price Schedule for Cable Trays & Accessories)" with bidder's signature & company stamp.

No other documentation is required to be submitted as technical offer. Any information contained in other parts of the offer (e.g. covering letter, annexures, etc.) which is deviating from specification requirements in any way shall not be considered by BHEL as part of offer.

7.2 Documents to be submitted by successful bidder after award of contract shall be as per Annexure-II.

7.3 Vendor drawing / document schedule for the project shall be as per Annexure – III.



**NORTH KARANPURA STPP (3 X
660MW) EPC PACKAGE**

**TECHNICAL SPECIFICATION FOR
CABLE TRAYS & ACCESSORIES**

SPECIFICATION NO. PE-TS-405-507-E021

VOLUME II B

SECTION D

REVISION 01

DATE: 05.06.2015

SHEET 1 of 2

DATASHEET-A

1.0 APPLICABLE STANDARDS

- a) IS: 1079 For hot rolled carbon steel sheet and strip.
b) IS: 1730 For dimensions for steel sheet and strip.
c) IS: 1363 Hexagon head bolts, screws and nuts.
d) IS: 2629 For hot dip galvanising of steel & surface pre treatment.
e) IS: 2633 For testing of zinc coating.
f) IS: 6745 For determining of mass of zinc coating.
g) IS: 1367 Galvanised Coating on threaded Fasteners.
(Part-XIII)
h) IS: 1852 For Rolling and Cutting Tolerances of hot rolled steel products.
i) IS: 9595 For thickness of welding of carbon & carbon manganese steels

2.0 CABLE TRAYS & ACCESSORIES

- 2.1 Material : Hot Rolled Mild Steel
- 2.2 Type : Ladder Type
Perforated Type
Cable trough
- 2.3 Standard Length of
Straight Length of
Cable Trays : 2.5 meters
- 2.4 Standard Width (mm) : Cable Trays : 600 300 150
Cable Trough: 75 50
- 2.5 Construction : Conforming to enclosed drawing [PE-DG-405-507-E005]
- 2.6 Bending Radius
of Accessories(in mm) : 600 mm
- 2.7 Tolerance in length/width
/ height : + /- 2 mm

3.0 FITTINGS

- End connections : Through Coupler plates
(Side Coupler Plates shall be provided as part of cable tray & accessories
supply with bolts, nuts, washers etc)

4.0 TRAY COVERS

- a) Type : Non-Perforated Type
b) Material : Hot Rolled Mild Steel
c) Width : Suitable for width of cable trays
d) Tolerance in length/
width/height : Same as cable trays



**NORTH KARANPURA STPP (3 X
660MW) EPC PACKAGE**

**TECHNICAL SPECIFICATION FOR
CABLE TRAYS & ACCESSORIES**

SPECIFICATION NO. PE-TS-405-507-E021

VOLUME II B

SECTION D

REVISION 01

DATE: 05.06.2015

SHEET 2 of 2

4.0 SHEET THICKNESS

- a) For cable trays & Accessories : 2.0 mm
b) For cable tray cover : 1.6 mm
c) For Coupler plate : 3.0 mm
d) Tolerance in Thickness : (+/- 0.2 mm)

6.0 SURFACE TREATMENT

- a) Pre-treatment : IS 2629 before galvanisation
b) Type : Hot dip galvanisation
c) Applicable Standard : IS 2629
d) Minimum thickness : 75 microns (minimum)
e) Min. weight of Zinc deposit : 610 grams per square meter
f) Tests for galvanizing : (i) Weight of Zinc Coating as per IS 6745.
(ii) Thickness of Zinc Coating as per IS 4759.
(iii) Uniformity of Zinc Coating as per IS 2633.
(iv) Adhesion Test as per IS 2629.

7.0 NUMBER OF COUPLER PLATES, BOLTS, WASHERS & NUTS REQUIRED FOR EACH CABLE TRAY SECTION (2.5 MTRS)

Sl. No.	NAME OF ITEM	COUPLER PLATE (nos.)	NUTS (nos.)	WASHERS (nos.)	BOLTS (nos.)
1	Cable tray of standard length 2.5 meters	4	16	32	16

NOTE: - Based on above table, no. of coupler plates, bolts, washers & nuts shall be calculated for the offered lot. Over & above the calculated quantity, additional 5% coupler plates & 10% bolts, washers & nuts shall be supplied by the bidder.

TYPICAL DETAILS OF CABLE TRAYS AND ACCESSORIES

NTPC DWG. NO. 4410-001-215-PVE-B-003									
REV. 01	DATE	ALTD HK	CHD MS	APPD RG	OWNER: NATIONAL THERMAL POWER CORPORATION				
1. REVISED IN LINE WITH CUSTOMER'S COMMENTS DTD. 05.11.2014. 2. CHANGES MARKED WITH					3X660 MW NORTH KARANPURA STPP				
405		BHARAT HEAVY ELECTRICALS LTD. POWER SECTOR PROJECT ENGINEERING MANAGEMENT NOIDA			DEPT CODE	DRN AV	NAME AV/HK	SIGN -sd-	DATE 21.03.14
CONTRACT					E	CHD AKR	-sd-	21.03.14	
DISTRIBUTION		TYPICAL DETAILS OF CABLE TRAYS AND ACCESSORIES			DRAWING NO. PE-DG-405-507-E005				
					SHEET 1 OF 11 REV. 01				

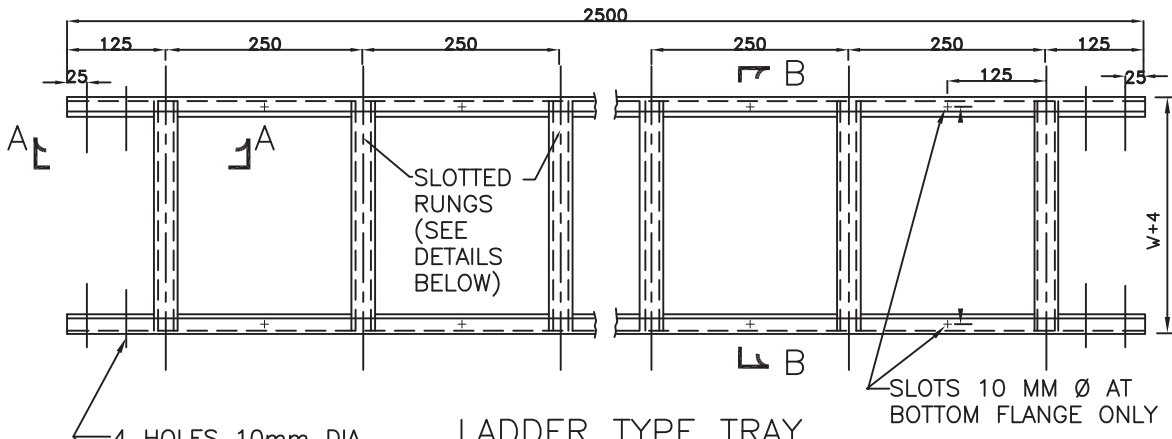

LADDER TYPE TRAY

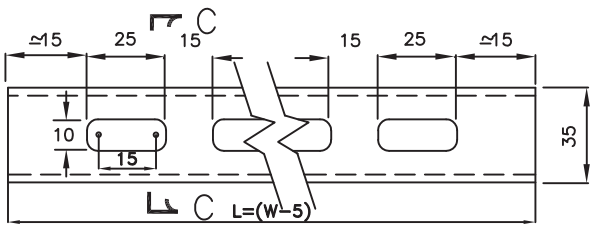
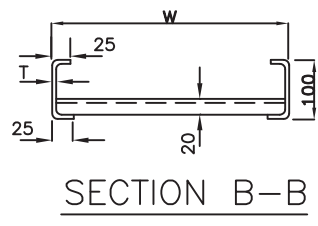
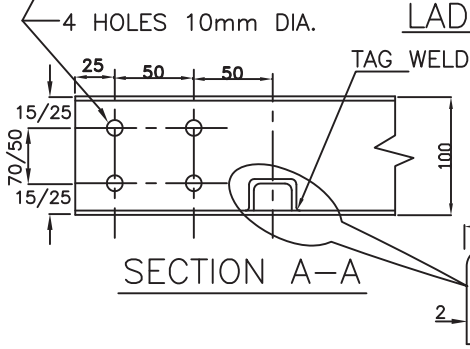

SLOTTED RUNGS
(TO SUIT TRAY WIDTH)

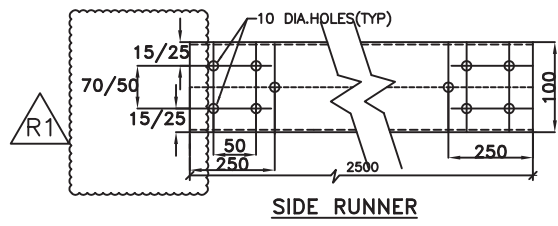

LADDER TYPE TRAY

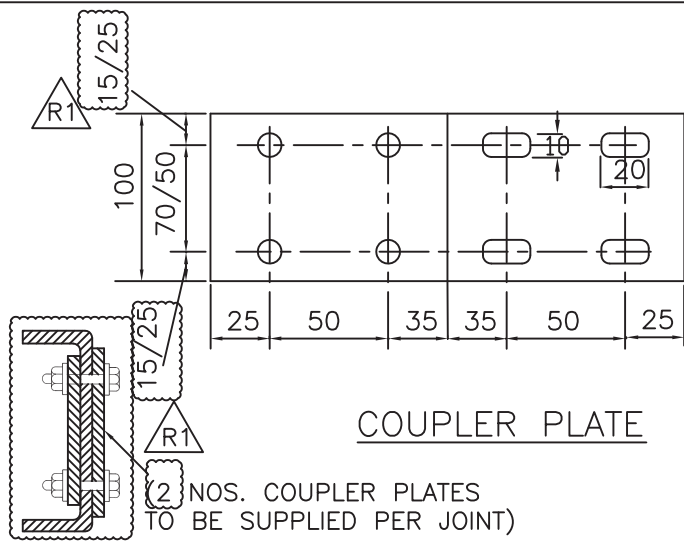

8 NUMBERS BOLTS
8mm DIA 20mm LONG
WITH NUTS AND
WASHERS ARE TO BE
SUPPLIED WITH EACH
COUPLER PLATE

20

8



TYPICAL DETAILS OF
CABLE TRAYS AND ACCESSORIES

DRAWING NO.
PE-DG-405-507-E005

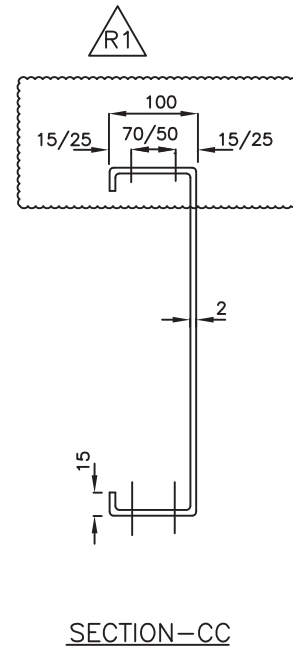
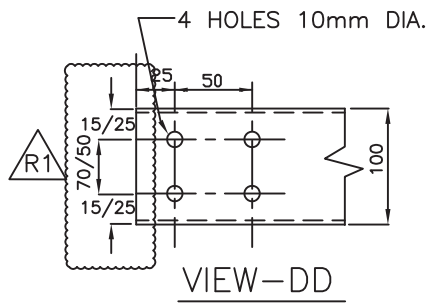
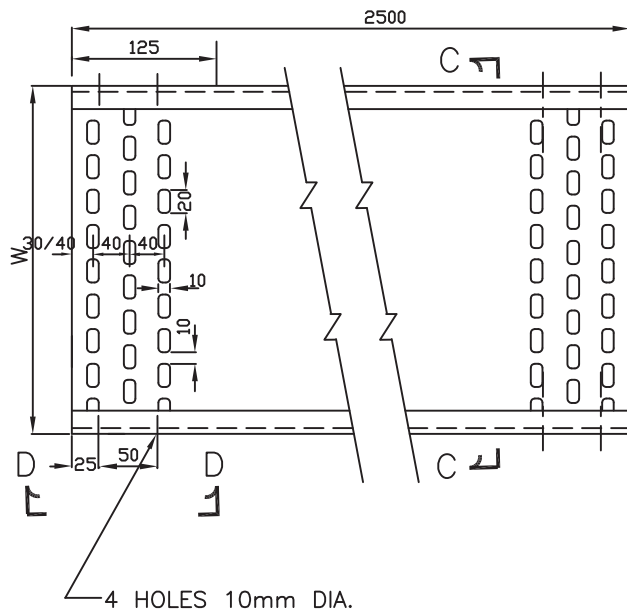

PERFORATED TYPE TRAY

SEE GENERAL NOTES IN SHEET 10.



TYPICAL DETAILS OF
CABLE TRAYS AND ACCESSORIES

DRAWING NO.

PE-DG-405-507-E005

SH 3 OF 11

REV 01

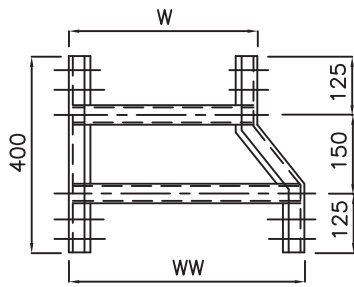

LEFT HAND REDUCER

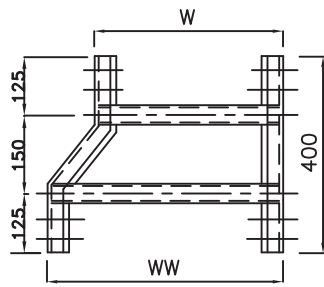

RIGHT HAND REDUCER

WW	W	DEPTH
600	300	100
600	150	100
300	150	100

LADDER TYPE

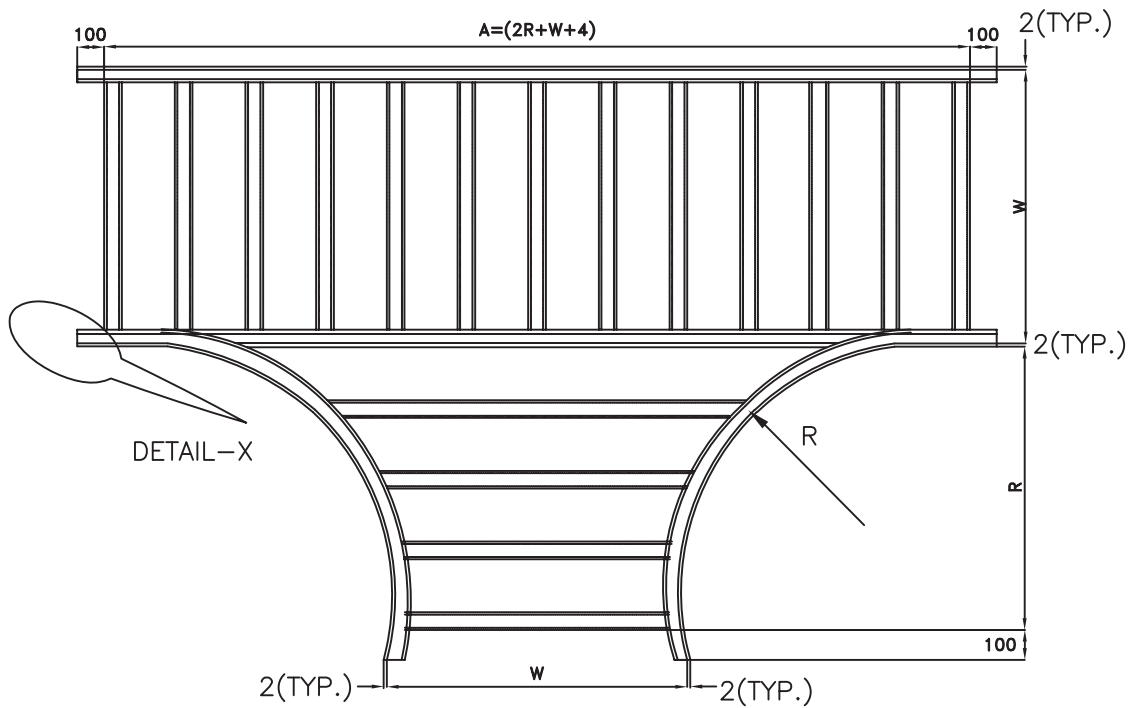

DETAIL-X

10mm DIA. HOLES

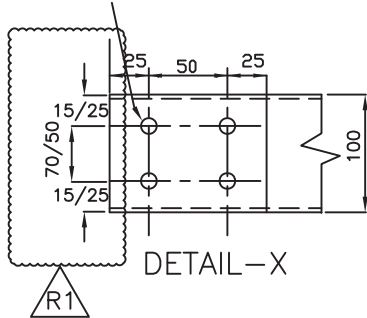

DETAIL-X

WIDTH W	BENDING RADIUS R	DEPTH	A		
			W		
			150	300	600
150, 300 & 600	600	100	1354	1504	1804

SEE GENERAL NOTES IN SHEET 10.

LADDER TYPE



TYPICAL DETAILS OF
CABLE TRAYS AND ACCESSORIES

DRAWING NO.

PE-DG-405-507-E005

SH 4 OF 11

REV 01

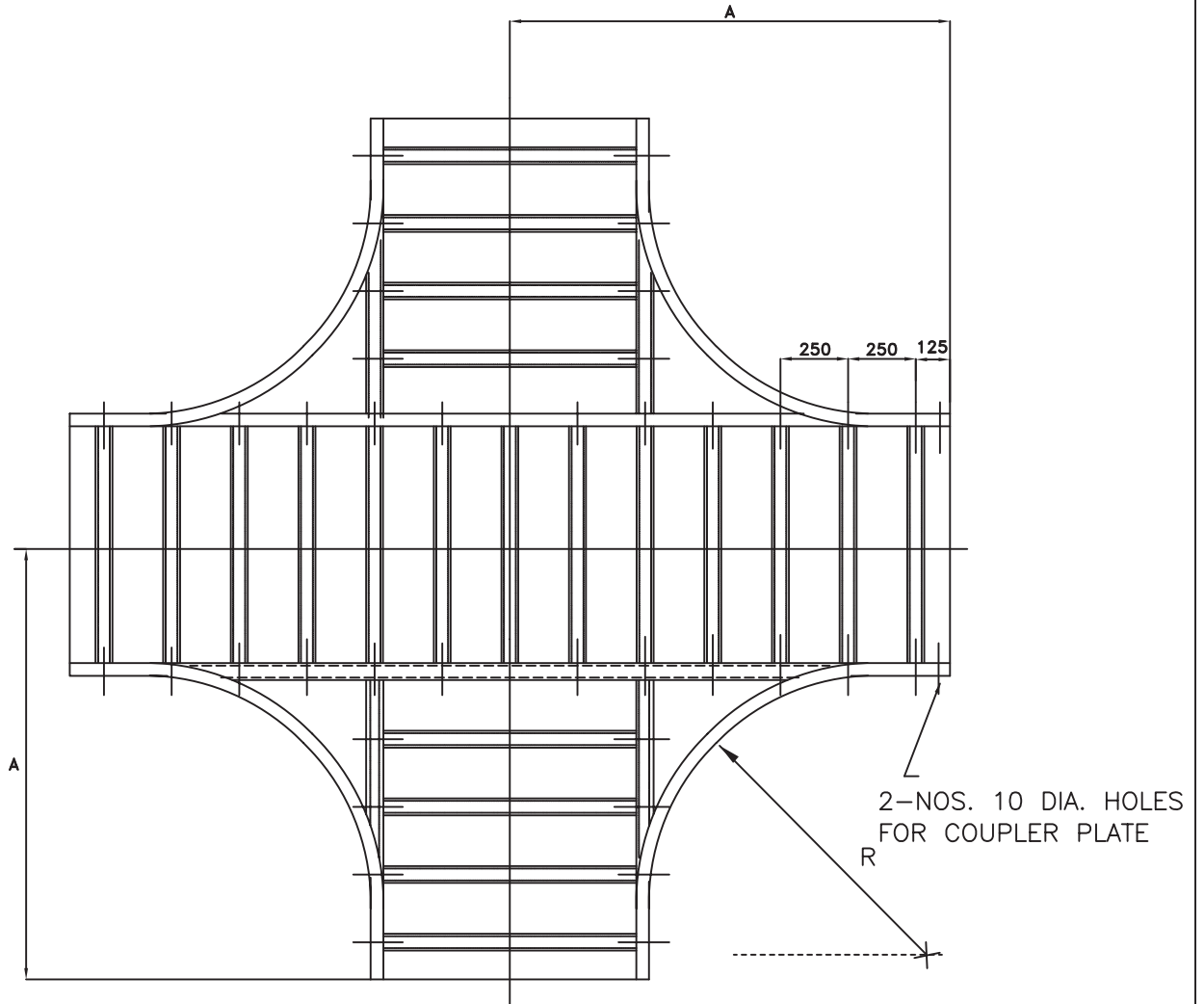

HORIZONTAL CROSS-PLAN

WIDTH W	BENDING RADIUS R	$A=R+W/2+100$
600	600	1000
300	600	850



TYPICAL DETAILS OF
CABLE TRAYS AND ACCESSORIES

DRAWING NO.

PE-DG-405-507-E005

SH 5 OF 11

REV 01

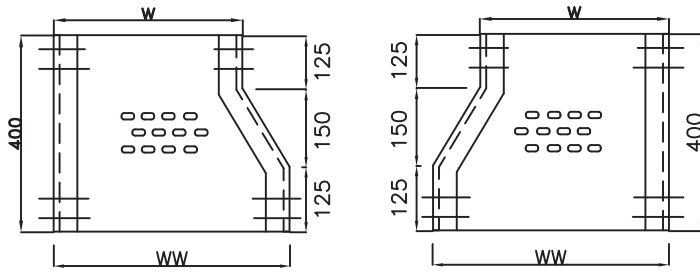

WW	W	DEPTH
600	300	100
600	150	100
300	150	100

LEFT HAND REDUCER RIGHT HAND REDUCER

PERFORATED TYPE

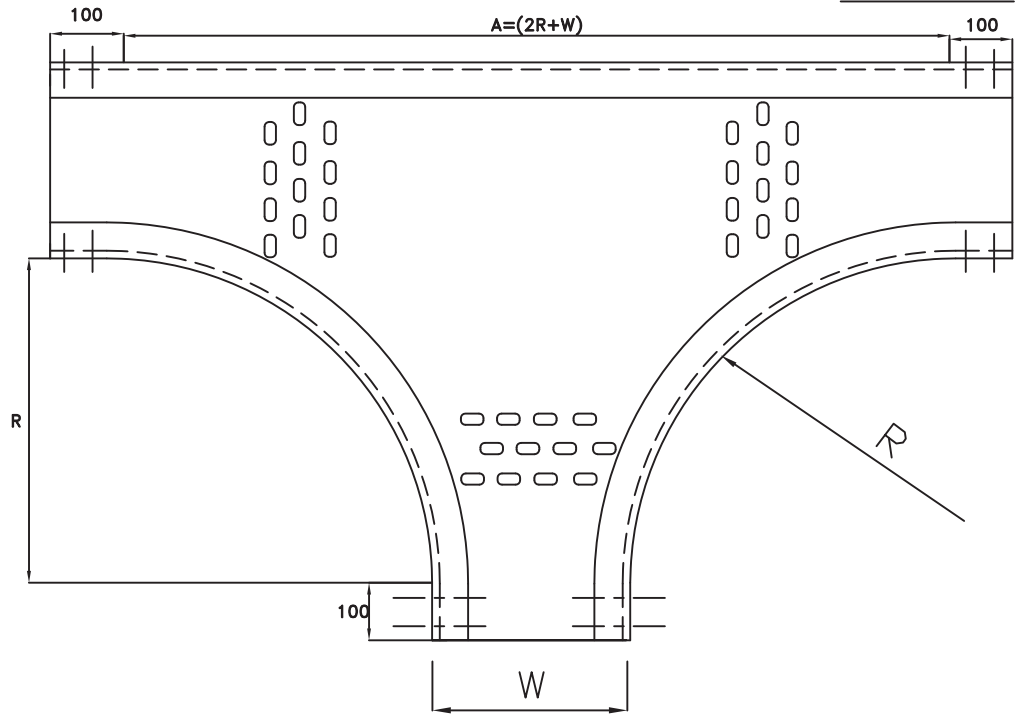
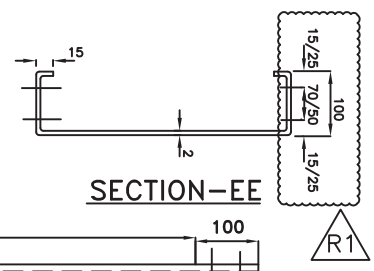

TEE

WIDTH W	BENDING RADIUS R	DEPTH	A		
			W		
			150	300	600
150, 300 & 600	600	100	1350	1500	1800

SEE GENERAL NOTES IN SHEET 10.

PERFORATED TYPE



TYPICAL DETAILS OF
CABLE TRAYS AND ACCESSORIES

DRAWING NO.
PE-DG-405-507-E005

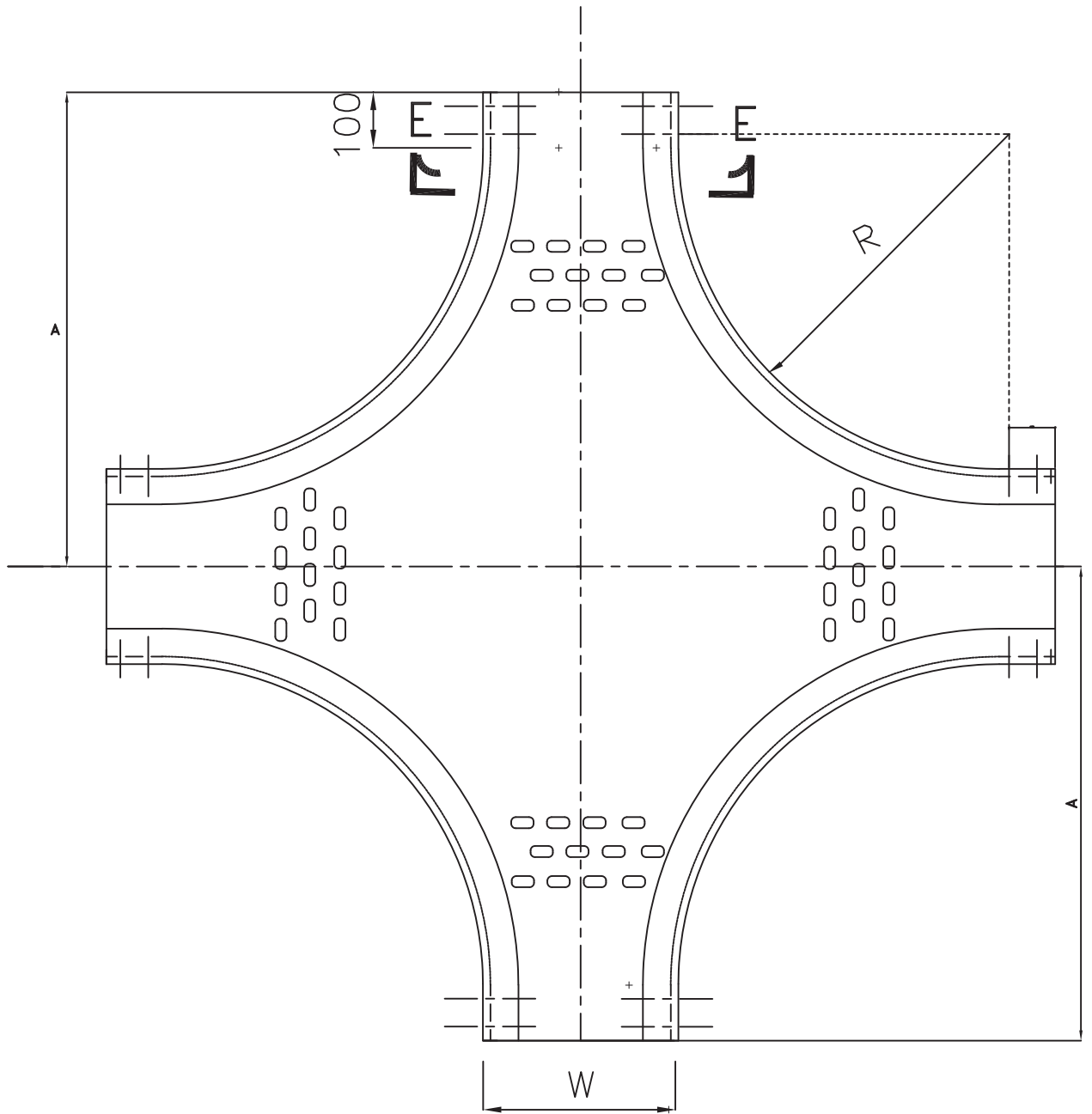

CROSS

WIDTH W	BENDING RADIUS R	$A=R+W/2+100$
600	600	1000
300	600	850



TYPICAL DETAILS OF
CABLE TRAYS AND ACCESSORIES

DRAWING NO.

PE-DG-405-507-E005

SH 7 OF 11

REV 01

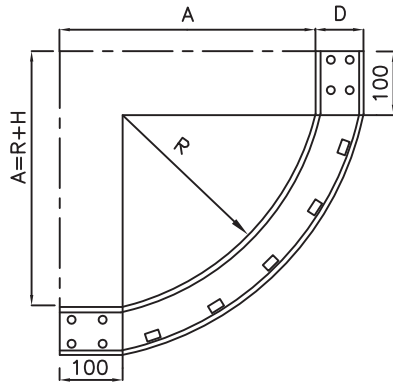

INSIDE TYPE

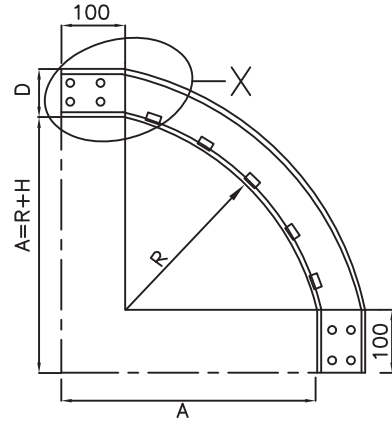

OUTSIDE TYPE

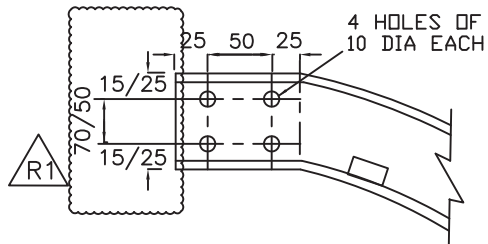

ENLARGED VIEW OF "X"

VERTICAL ELBOW 90 DEG UP/DOWN

INSIDE WIDTH W	BENDING RADIUS R	DEPTH	A
600, 300 & 150	600	100	700

90° VERTICAL BEND - LADDER TYPE

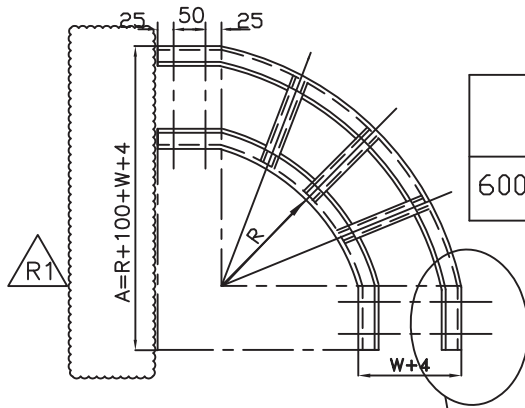

LADDER TYPE

X (AS ABOVE)

HORIZONTAL ELBOW 90 DEG

INSIDE WIDTH W	BENDING RADIUS R	DEPTH	A		
			150	300	600
600, 300 & 150	600	100	854	1004	1304

90° HORIZONTAL BEND - LADDER TYPE

SEE GENERAL NOTES IN SHEET 10.



TYPICAL DETAILS OF
CABLE TRAYS AND ACCESSORIES

DRAWING NO.

PE-DG-405-507-E005

SH 8 OF 11

REV 01

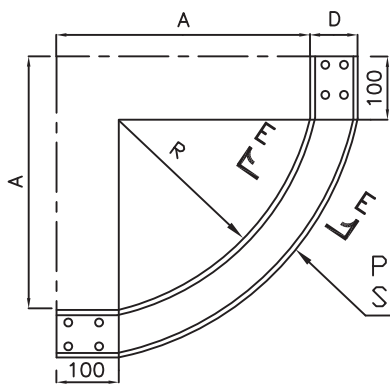

INSIDE TYPE

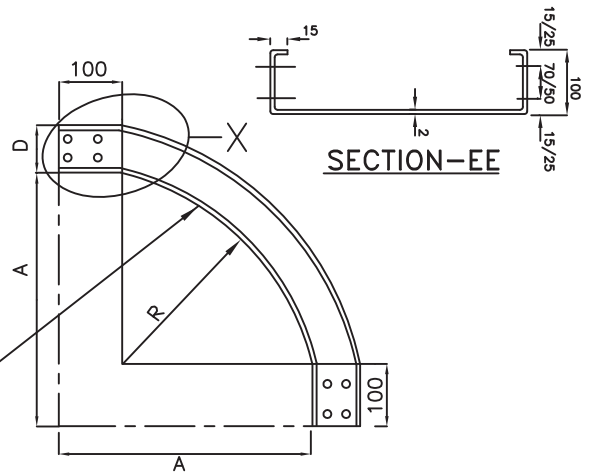

OUTSIDE TYPE

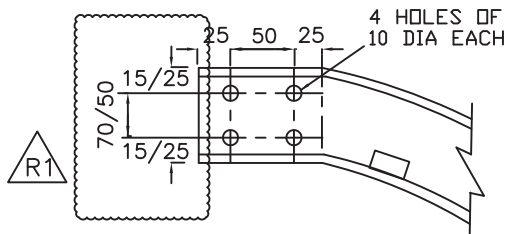

ENLARGED VIEW OF "X"

VERTICAL ELBOW 90 DEG UP/DOWN

INSIDE WIDTH W	BENDING RADIUS R	DEPTH	A
600, 300 & 150	600	100	700

90° VERTICAL BEND - PERFORATED TYPE

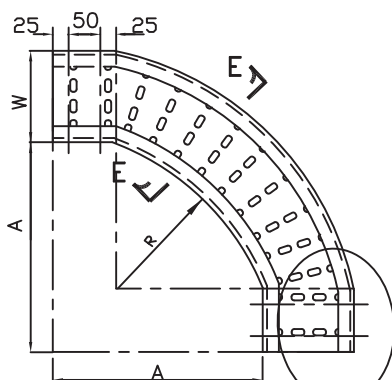

X (AS ABOVE)

HORIZONTAL ELBOW 90 DEG

INSIDE WIDTH W	BENDING RADIUS R	DEPTH	A		
			150	300	600
600, 300 & 150	600	100	854	1004	1304

90° HORIZONTAL BEND - PERFORATED TYPE

SEE GENERAL NOTES IN SHEET 10.



TYPICAL DETAILS OF
CABLE TRAYS AND ACCESSORIES

DRAWING NO.

PE-DG-405-507-E005

SH 9 OF 11

REV 01

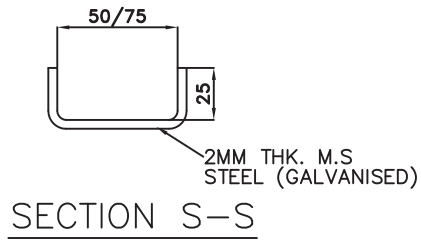
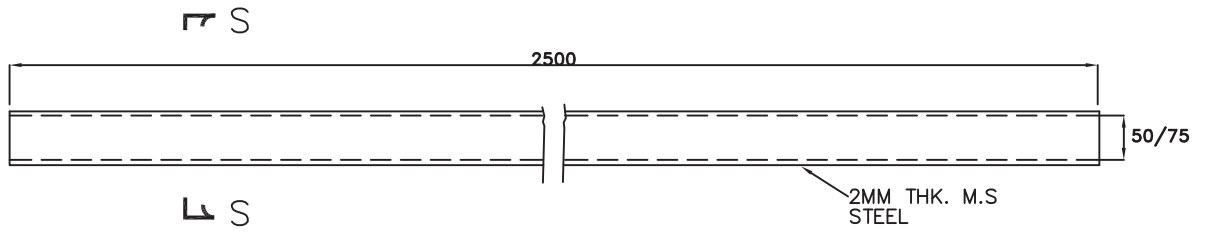

CABLE TROUGHS

SEE GENERAL NOTES IN SHEET 10.



TYPICAL DETAILS OF
CABLE TRAY AND ACCESSORIES

BHEL DRAWING NO.
PE-DG-405-507-E005

SH 10 OF 11

REV 01

NOTES:—

1. THE CABLE TRAYS AND ACCESSORIES SHALL BE MADE OF 2mm M.S.SHEET CONFIRMING TO IS:1079.
2. THE CABLE TRAYS AND ACCESSORIES SHALL BE HOT DIP GALVANISED AS PER IS 2629.
3. FOR LADDER TYPE CABLE TRAYS AND ACCESSORIES, ALL RUNGS SHALL BE SLOTTED.
4. PERFORATED TRAYS SHALL BE FABRICATED OUT OF A SINGLE M.S. SHEET.
5. THE DIMENSIONS OF ALL BENDS, TEES, CROSSES, ETC. FOR PERFORATED CABLE TRAYS SHALL BE THE SAME AS FOR LADDER TYPE TRAY FITTINGS.
6. SIDE CHANNELS OF PERFORATED TRAY ACCESSORIES SHALL BE WELDED WITH THE PERFORATED SHEET AT INTERVALS OF 100mm.
7. LENGTH OF WELDING SHALL NOT BE LESS THAN 25mm. WELDING SHALL BE AS PER IS 9595.
8. PREFERABLY SINGLE MS PERFORATED SHEET SHALL BE USED AS BASE OF ALL PERFORATED TYPE TRAY ACCESSORIES. HOWEVER, IF USE OF PIECES OF PERFORATED SHEET IS UNAVOIDABLE FOR BASE, PIECES SHALL BE WELDED WITH EACH OTHER IN LINE WITH THE ABOVE.
9. ALL TRAY CORNERS SHALL BE FREE OF SHARP EDGES & SMOOTH.
10. THE DEPTH, WIDTH AND LENGTH OF TRAYS AND ACCESSORIES SHALL BE WITHIN A TOLERANCE AS PER RELEVANT IS
11. TO FACILITATE ASSEMBLY, ALL ACCESSORIES AT ENDS SHALL HAVE 100mm STRAIGHT PORTION.
12. ALL NUTS, BOLTS, WASHERS ETC., SHALL BE HOT DIP GALVANISED AS PER IS 1367 FOR SIZES ABOVE 12MM AND ELECTROPLATED/ELECTROGALVANISED FROM SIZE BELOW 12MM.
13. ALL DIMENSIONS ARE IN mm UNLESS NOTED OTHERWISE.
14. TRAY ACCESSORIES SHOWN IN THIS DRAWING SHALL BE FACTORY FABRICATED FOR USE AT SITE AS PER APPROVED LAYOUT DRAWINGS. FOR SPECIFIC SITE REQUIREMENTS (E.G. IRREGULAR ANGLE BENDS SUCH AS 30°/60° BENDS, ETC) AS PER SITE LAYOUT CONDITIONS, TRAY ACCESSORIES SHALL BE FABRICATED AT SITE FROM THE STRAIGHT LENGTH OF RESPECTIVE SIZES AS REQUIRED. GALVANISATION DAMAGED DURING CUTTING/WELDING OPERATIONS SHALL BE BRUSHED AND RED LEAD PRIMER, OIL PRIMER AND ALUMINIUM PAINT SHALL BE APPLIED BEFORE INSTALLATION OF THE ACCESSORIES.
15. WIDTH OF CABLE TRAYS PROPOSED TO BE USED FOR PROJECT ARE AS UNDER :
LADDER TYPE CABLE TRAY (MM) : 600,300 & 150
PERFORATED TYPE CABLE TRAY (MM) : 600,300,150
16. 600MM WIDE CABLE TRAY SHALL BE SUITABLE FOR WEIGHT OF 100KG/M INCLUDING LIVE LOAD OF RUNNING LENGTH OF CABLE TRAY.
17. CABLE TROUGHS SHALL BE USED FOR BRANCHING OUT FEW CABLES FROM MAIN CABLE ROUTE.
18. MAKE OF ALL ITEMS SHALL BE AS PER NTPC QA APPROVAL.

R1



TYPICAL DETAILS OF CABLE TRAYS AND ACCESSORIES

DRAWING NO.

PE-DG-405-507-E005

SH 11 OF 11

REV 01