



BHARAT HEAVY ELECTRICALS LIMITED

TRANSMISSION BUSINESS ENGINEERING MANAGEMENT

COPYRIGHT AND CONFIDENTIALITY
The information on this document is the property of BHARAT HEAVY ELECTRICALS LTD.
It must not be used directly or indirectly in anyway detrimental to the interest of the company

DOCUMENT No.	TB-357-552-032	Rev. No.	00	Prepared	Reviewed	Approved
TYPE OF DOC.	TECHNICAL SPECIFICATION			SIGN		
TITLE FIREFIGHTING SYSTEM FOR SWITCHYARD	NAME	TDT	SKS	SS		
	DATE	12.09.13	12.09.13	12.09.13		
	GROUP	TBEM	W.O. No	82003		
CUSTOMER	BIHAR STATE ELECTRICITY BOARD (BSEB)					
PROJECT	220 /132 kV PUSAULI SUB-STATION & DEHRI EXTN.					
CONTENTS						
Section	Description					No. of Sheets
1	Intent, System requirement, Design Criteria and Scope.					12
2	Equipment Specification					42
3	Project Details and General Specifications					11
4	Guaranteed Technical Particulars					2
5	Schedules to be filled by the Bidder					8
	<ul style="list-style-type: none"> ▪ <u>Drawings</u> <ul style="list-style-type: none"> a. Layout Plan of 220/ 33 kV Switchyard b. Conceptual Layout of Control Room Building c. P & I Diagram d. OGA drawings of Transformer 					
Rev No.	Date	Altered	Checked	Approved	REVISION DETAILS	
Distribution				To	TBMM	Vendor
				Copies	1	4

SECTION 1

INTENT, SYSTEM REQUIREMENT, DESIGN CRITERIA AND SCOPE

1.0 INTENT OF SPECIFICATION

- 1.0.0 This specification is intended to cover following activities and services in respect of all the equipment of the **Fire detection and protection System to be provided for 220/132 kV Pusauli Substation and dehri Extn. of Bihar state Electricity Board (BSEB).**
- i) Detailed design of all the equipment and equipment system(s).
 - ii) Complete manufacturing including shop testing.
 - iii) Providing engineering data, drawings, and O & M manuals as per specified format etc. for Owner's/Purchaser's review, approval and records.
 - iv) Packing and transportation from the manufacturer's works to the site including customs clearance/port clearance, if required.
 - v) Receipt, storage, preservation and conservation of equipment at site.
 - vi) Fabrication, pre-assembly, if any, erection testing and putting into satisfactory operation all the equipment including successful completion of trial operation.
 - vii) Performance and Guarantee tests after successful completion of trial operation.
- 1.0.1 The requirements specified under SECTION 2, SECTION 3, SECTION 4 & SECTION 5 of the specification shall be considered as part of this section. In the event of any conflict between the various sections/sub-sections of this specification, SECTION 1 shall prevail. It is not the intent to specify herein all the details of design and manufacture. However, the equipment and the system shall conform in all respects to high standards of design, engineering and workmanship and shall be capable of performing the required duties in a manner acceptable to Purchaser/ Owner, who will interpret the meaning of drawings and specifications and shall be entitled to reject any work or material, which in his judgment is not in full accordance herewith.
- 1.0.2 **Contract shall be on lumpsum basis for the scope defined in the specification. Within the scope of the contract, no variation shall be admissible to the contractor so far the input remains unchanged. The Bidder shall be responsible for providing all material, equipment and services, specified or otherwise which are required to fulfill the intent of ensuring operability, maintainability and the reliability of the complete work covered under this specification.**
- 1.0.3 The Bidder shall deem to have understood completely all the tender drawings and documents and quoted accordingly.
- 1.0.4 **Deviation:** There shall preferably be no deviation on technical specification. The bidder shall sign and stamp the "Certificate for No Deviation" enclosed in Schedule-2 of Section-5 towards confirmation. Except for these deviations/variations covered under Deviation Schedules which are accepted by the Purchaser before the award of the Contract, it will be the responsibility of the Bidder to fully meet the intent and the requirements of the specification within the quoted price. *Deviations in any other form including clarifications / assumptions / etc will not be considered and it will be construed that the bid conforms strictly to the specification.*
- 1.0.5 The Bidder to note carefully that the parameters, estimated capacities of equipment indicated and the tender drawings in the specification are only for the guidance of the Bidder. The system shall be

designed as per relevant standards/ codes and exact capacities and quantities are to be estimated by the Bidder. All such estimations and design calculations shall be submitted for Purchaser's approval.

- 1.0.6 It is the responsibility of the successful Bidder to obtain necessary approval/ clearance from statutory organizations wherever applicable for the equipment/ systems under the scope specified.
- 1.0.7 The term 'Owner' appearing in this specification shall refer to **Bihar State Electricity Board (BSEB)**, the term 'Purchaser' shall refer to **BHEL** and the term 'Contractor' shall refer to the **successful Bidder**.

2.0 FIRE FIGHTING REQUIREMENTS FOR VARIOUS AREAS

The makes/models and technical features offered for various firefighting system components/ equipment shall comply with the standards of TAC/ BIS/ UL/ VDs and FM / NFPA/ LPCB as applicable. The key elements of fire protection cum detection scheme and the related areas are presented as under:

System	Areas Protected
Hydrant System	i. Control Building, FF Pump house, Transformers.
HVW Spray System	i. 150 MVA Transformer (2 nos.)
Addressable Fire Detection & System	i. Control Building
Portable Fire Extinguisher	i. Control Building

- ❖ Water supply requirements for Hydrant & HVW spray system will be catered by a firefighting pump house.

3.0 SYSTEM REQUIREMENT & DESIGN PHILOSOPHY

This system shall be designed to provide fire detection and protection services for Switchyard and its control Building. Design criterion shall be based on "**Light Hazard Occupancies**" classification as described in Tariff Advisory Committee's (TAC) guidelines. All equipment or systems in the designed fire detection cum protection arrangement shall be completely in compliance with the regulations of Tariff Advisory Committee (TAC) of India/ Loss Prevention Association (LPA) / National Fire Protection Association (NFPA)/LPCB/ VDs.

3.1 Detection System

- The system shall consist of addressable manual call points, addressable multisensor smoke detectors, heat detectors, hooter, addressable interface units, microprocessor based fire alarm panel as required for the complete system with associated cabling and cabling accessories, etc.
- All detection and sensing devices forming an integral part of the microprocessor based, addressable, intelligent fire detection and alarm system shall be approved by UL/FOC/ Any other internationally recognized body acceptable to the Owner.
- Area Coverage for each smoke detector shall be 80 m² and each heat detector shall be 40 m².

- d) Addressable multi-sensor type smoke detectors shall be provided in all areas of Control Building except for the Battery room & pantry where Addressable rate of rise of heat detector shall be provided.
- e) Manual call points with flame proof enclosure shall be located at each floor of control building such that no person needs to travel more than 30 meters from any point within the premises, in order to give an alarm. Manual call points shall be located on the exit routes and in particular on floor landings of stair cases and near exits from the control building.
- f) All the detectors in the switchyard control building shall be looped into a Fire Alarm Panel situated in the switchyard control building.
- g) Single loop Fire Alarm cum annunciation panel of analogue addressable type shall be dedicated to Switchyard control building which shall evaluate the signals received from the detectors, transmit the fire or trouble alarms (audio-visual) to prearranged points, supervise and monitor the complete fire detection circuits. All the important annunciations from the pump house shall be repeated in this fire alarm cum annunciation panel.
- h) The fire alarm panel shall be designed to include all the standard features and shall also accommodate programmed activation of various interlocks with fire protection system and other associated systems and programmed activation of sequence of events to be carried out in case of fire in any particular protective area.
- i) All the circuits from the detectors to the panels and the circuits from the panels to the actuating devices shall be closed loop type and shall be supervised for open and short circuiting.
- j) Facilities shall be provided on the fire alarm panel for simulating fire conditions, sensitivity adjustment, isolation of detectors etc. from the panel.
- k) Fire alarm control panel shall have filters to ignore false alarm and increase sensitivity to real fire from sensors and provision for automatic re-calibration of sensitivity levels of over / under sensitive detectors. The sensitivity of each detector should be automatically raised if detectors are gradually polluted due to dust and dirt entering inside the detector. If detectors are more polluted the control panel shall give a warning. The trouble report shall indicate the location of device requiring service.
- l) All devices shall be individually identifiable for its type, its zone location, and alarm set value, alarm and trouble indication by a unique alpha numerical label.
- m) The detectors shall be self compensating for ambient temperature and humidity.
- n) The detectors shall display a steady LED when in the alarm state. The LED shall flash when in standby or normal mode.
- o) Each floor shall be provided with one electronic hooter besides the staircase.
- p) All detectors and interface units for detectors which do not have response indicators shall be provided with local LED response indicators which will light up steadily when the detectors sense a fire and operates.
- q) In air conditioned areas of control room where false ceiling is present, the detectors shall be installed both above and below false ceiling. For above false ceiling detectors a response indicator shall be provided below false ceiling for the purpose of detector's alarm status indication.

- r) However other factors like beam depth and area separation criterion shall also be implemented in deciding coverage of each of the detectors.
- s) Incipient fires sensed by these detectors shall trigger an alarm at the FAP.
- t) Complete fire detection, alarm monitoring and annunciation system from the panels shall be operated on DC supply, suitably converted by a dedicated rectifier bank taking supply from each of the panel. Further FAP panel shall be provided with 1x100% Batteries and 1x100% Battery chargers with provision for automatic change over from mains to batteries, automatic charging etc.
- u) Each set of battery shall be of adequate capacity to supply fire detection and alarm system and as well actuating devices such as solenoid valves etc. for a period of 6 hours from the instant of charger/ AC failure.
- v) The Batteries shall be of maintenance free Lead -acid type.
- w) The detector cable and other control cable shall be armored, screened and twisted pair FRLS type which shall be cleated to roof/wall surface.

3.2 Firefighting Pump House Requirements

Water for hydrant & HVWS system shall be supplied by the following pumps in the pump house building:

- i. Electrical motor driven pump of rated capacity 410 m³/hr at 70 MWC head (one no.)
- ii. Diesel engine driven pump of rated capacity 410 m³/hr at 70 MWC head shall be used as standby pump.
- iii. Jokey pumps (1 no. working + 1 no. standby) of rated capacity 10.8 m³/hr at 80 MWC shall be used to keep the system pressurized.

Pumps shall work under positive suction head. Annunciations of the pumps & HVW spray systems shall be provided in fire water pump house Annunciation panel and the same shall be repeated in the control room.

An air vessel of 2 cu.meter shall be provided in the delivery header.

A pressure relief valve of suitable rating shall be provided in water header to release excess pressure due to atmospheric temperature variations.

Operation of all the pumps shall be automatic and pumps shall be brought into operation at preset pressure. Fire pumps shall only be stopped manually. Manual start/stop provision shall be provided in local control panel.

2 x 100% Batteries with 2 x 100% battery chargers shall be provided for diesel engines. Charger unit shall be capable of charging one set of battery at a time however provision shall be made that one of the charger can be utilized for charging either of the batteries. Battery capacity shall be adequate for 10 consecutive starts without recharging with a cold engine under full compression.

Water storage tank of 450 cu. m. divided suitably in two equal compartments i.e. each of 225 cu.m capacity will be provided near to firefighting pump house.

Tap off point for the supply of water to the water storage tank will be within 10 m of firefighting pump house building.

3.2.1 Electrical panels:

The following panels shall be provided in the pump house

- i. LCP for electrically driven hydrant/ spray pump
- ii. LCP for 2 nos. Jockey pump
- iii. LCP for battery chargers and diesel engine driven standby hydrant/ spray pump
- iv. AC Distribution Board
- v. DC Distribution Board
- vi. Window type Annunciation Panel

Annunciations from the pump house shall be repeated microprocessor based Fire Alarm cum annunciation panel in the Control room.

3.2.1 Hydrant System

This system shall cover the following risk areas:

- i. Control Room Building
- ii. Transformer (2 nos.)
- iii. Fire Fighting Pump house

Pressurized Fire hydrant system essentially consists of a network of above ground pipes. Approximately **7nos.** single headed Hydrant valves shall be provided for above mentioned areas.

- a. Hydrant risers in staircases shall be provided with isolation valves.
- b. Gate Valve type isolation valves shall be suitably provided in Hydrant mains to isolate sections of piping for maintenance purpose.
- c. System shall be designed in a way so that minimum terminal pressure of 3.5 kg/ cm² can be maintained at the farthest/remotest hydrant point of the switchyard.
- d. All the outdoor & indoor hydrants shall be provided with a front glass type hose box carrying 2 nos. 15 mtrs hose for outdoor hydrant & 2 nos. 7.5 mtrs hose for indoor hydrant along with branch pipe coupling and nozzle.
- e. All hydrant pipe lines shall be routed aboveground on RCC pedestals .Road, Rail or pipe trench crossing shall be through RCC Hume pipes duly covered with coating and wrapping as per specification. Hume pipe for road crossing shall be NP3 class and that for rail crossing shall be NP4.

Specific Data

- a. All hydrant valves shall be of 63 NB dia. Single headed, oblique type having Gun metal construction conforming to IS: 5290 or Equivalent.
- b. Hoses shall be of non-percolating flexible (RRL type) as per IS: 636 (type B).
- c. All the pipes shall be of medium grade type. Overground/ Buried pipes shall be of mild steel black pipes as per IS: 1239, Part-I medium grade (for pipes of sizes 150 NB and below) or IS: 3589, Fe 410

grade (for pipes of sizes 200 NB and above) duly covered with coating and wrapping as per IS: 10221 as per specification.

- d. Overground pipes normally empty, but periodic charge of water and for detector line for spray system shall be of mild steel galvanized pipes as per IS: 1239, Part-I medium grade (for pipes of sizes 150 NB and below) or IS: 3589 (for pipes of sizes 200 NB and above).
- e. All fittings to be used for piping should be as per IS 1239 part II for fittings 150 NB & below & Fabricated from parent pipes for 200 NB & above. All fitting used in GI piping shall be threaded type. Welding shall not be permitted on GI piping.
- f. For MS pipeline, welded construction should be adopted unless specified otherwise.
- g. All piping system shall be capable of withstanding the maximum pressure (1.5 times of the maximum working pressure) arising from any condition of operation and testing including water hammer effects.
- h. All the above ground piping shall be painted with two coats of red primer. Two coats of enamel paint shall be also are applied.
- i. Cast iron gate/sluice valve will be used for isolation of flow in pipe lines. Valves shall be of rising spindle type. PN 1.6 class.
- j. Cast Iron non-return valves shall be swing check type. Valves will have a permanent "arrow" inscription on its body to indicate direction of flow of the fluid.
- k. Valves below 50 mm size shall have screwed ends while those of 50 mm and higher sizes shall have flanged connections.

3.2.2 HVW Spray System

- HVW Spray System is envisaged for 2 nos. 150 MVA transformers in the switchyard.

General

Each of these transformers shall be surrounded with pipe rings having spray nozzles and quartzoid bulb detectors. The pipe ring with spray nozzles shall be connected to the downstream side of a pressure operated Deluge Valve. The upstream side shall be connected to the Pump in Pump House.

The QB detector network shall always be under pressurized conditions. This shall be achieved through a connection from upstream side of DV. In case of fire these detectors shall explode at a pre-determined temperature thereby releasing the pressure from the downstream side of DV. This shall open the deluge valve and simultaneously start the Pump. Thus water shall be sprayed on the equipment under fire.

Start signal to the pump shall be given through a pressure switch – which shall sense drop in pressure upto a preset value, in the common header and accordingly issue a signal to the control cum annunciation panel for starting the pump. Provision for local/remote- manual operation of the system shall also be provided.

Annunciation for DV open shall be displayed on Fire Alarm panel.

Design Criteria

- a. The system shall consist of water supply system, suitable number of spray nozzles, deluge valve, strainers, pipes and necessary valves. Wet type detection shall be provided for actuating the Deluge

system.

- b. Design discharge density for HVW Spray system shall be 10.2 lpm/ sqm as per the rules of water spray system of Tariff Advisory Committee (TAC).
- c. Minimum water pressure at the farthest and / or highest projector on the equipment protected shall be 3.5 kg/cm². However water pressure at any point shall not exceed 5 kg/cm².
- d. The automatic actuation of the deluge valve shall be by means of Quartzoid bulb detectors of 79°C type.
- e. An isolation valve shall be provided at upstream of each of the deluge valve. The size shall be same as that of the deluge valve.
- f. Fast acting butterfly valves will be provided on the downstream of deluge valve, so that this valve can be kept closed and can be operated manually, if there is any malfunction of deluge valves.
- g. Water motor gong shall form part of accessories to be provided with deluge valve.
- h. A strainer ('Y' type) shall be provided at upstream of deluge valve.
- i. Pressure gauges at both upstream and downstream of deluge valves, and in the detector pipe network shall be provided.
- j. Pressure switches shall be provided in spray and QB detector piping to exhibit "FIRE" and "SPRAY ON" annunciations and as well as for interlock.
- k. All Spray pipe mains/ pipe lines shall be routed aboveground on RCC pedestals. Road, Rail or pipe trench crossing shall be through RCC Hume pipes duly covered with coating and wrapping as per specification. Hume pipe for road crossing shall be NP3 class and that for rail crossing shall be NP4.
- a. Facility for remote actuation of deluge valves, through a push-button shall be provided. Local control panel for each deluge valve shall be provided.

3.2.3 Portable Fire Extinguishers

The switchyard control building including cable vault shall be provided with:

- Carbon dioxide of 4.5 kg capacity portable fire extinguisher conforming to IS: 15683.
- Dry chemical powder type 6 kg capacity portable fire extinguishers conforming to IS: 15683.
- Selection of type and location of installation of fire extinguishers for the various rooms of the switchyard control building shall be done in accordance with TAC guidelines.

4.0 SCOPE OF SUPPLY & SERVICES

4.1. Exact requirements shall be worked out during detailed engineering after award of contract. The scope of the work under the contract shall be deemed to include all such items, which although not specifically mentioned in the bid documents and/or in the bidder's proposal, but are required to make the equipment/system complete for its safe, efficient, reliable and trouble free operation, unless the same is specifically excluded from the Bidder's scope of work under clause 5.0 of this section.

4.2. Bidders shall consider reputed makes for various equipments which shall be subjected to Owner's approval during design engineering stage.

4.3. Bidder shall also consider the following while quoting for the system:

- i) Power & Control cables for fire protection system (except for cable for detection and alarm system) will be supplied on free issue basis to contractor. BHEL shall procure various sizes of cables (as per Annexure 'A' of this section) for the complete requirement of sub-station. Contractor shall have to choose their cables from the available sizes only and necessary modifications in their equipment for termination of these cables shall be made by contractor.
- ii) Since laying & termination of all power & control cables is in contractor's scope, supply of cable accessories such as lugs, glands, cable tags & markers etc. shall be included by the bidders in their offers alongwith supply of cable (2 X 1.5 sq.mm, FRLS, twisted pair, armoured Cu cable) for fire detection and alarm system.
- iii) Necessary cable trays will be supplied on free issue basis to the contractor, however necessary hardware for fixing the same on walls or elsewhere shall be included by the bidders in their offers.
- iv) Earthing material viz. GS flat & wire will also be supplied on free issue basis to contractor; however requirement shall be given by the bidders in their respective bids.
- v) Bidder shall ensure that sufficient quantities of commissioning spares are made available for timely completion of commissioning of the system. The bidder shall furnish a list of Commissioning spares that will be brought by him. The unused commissioning spares shall be returnable to the Bidder.
- vi) The contractor shall lay the underground piping required for hydrant system and also shall construct RCC pedestals & pylon supports for above ground pipe if required.
- vii) Pipe size for pylon, size of Anchor fasteners etc. shall be adequate for the support to provide sufficient rigidity against vibration & load during operation. The whole arrangement shall be in bidder's scope. The contractor shall justify adequacy of design during engineering.
- viii) Conducting performance guarantee tests as per approved procedure to the satisfaction of Owner / Purchaser and handing over an operational system to the owner. Procedure for performance guarantee test shall be submitted by contractor for customer review and approval.
- ix) Contractor shall submit valid Type test report for approval by owner. Fresh type test of equipment is not envisaged. It is presumed that equipment offered is duly type tested.
 - Type Test Certificate for degree of protection shall be submitted for the following:
 - a) All other electrical panels shall be as per customer specification.

In case the type test reports are found un-satisfactory, tests shall be carried out afresh by contractor without any additional cost implication to BHEL. However, inspite of a valid type test report if any of the tests are required to be repeated, same shall be payable to contractor on the basis of unit rates quoted by him.

Bidder shall therefore furnish the charges for type test (degree of protection) for above panels in his Bid.
- x) Bidder shall include one set of standard tools and tackles required for maintenance of the system. The list of tools required shall be furnished in the bid.

4.4. Scope of services

A. Erection, Testing & Commissioning (ETC) requirements

- i) The scope of ETC shall include receipt of material at site, unloading, safe storage of material, handling of equipment/ material at site, erection of equipment /material at site including fabrication, equipment and system testing, commissioning of the entire system, conducting performance guarantee tests to the satisfaction of Owner / Purchaser and final handing over to the owner of the entire system.
- ii) Furnishing technical calculations in support of equipment selection or sizing as and when required.

B. Interfacing

- i) Interconnecting solenoid operated fire dampers to close in case of fire.
- ii) Interlocking AC and Ventilation system with FF system such that these systems trip upon detection of fire.

10 nos. low current potential free contact(s) shall be made available in Fire Detection system panel for future use.

C. With Other Electrical System

- i) Preparations of cable interconnection diagram for equipment supplied under this contract and accordingly offer guidance to the purchaser for laying necessary cables. Termination details shall also be furnished in the said interconnection table.
- ii) Laying & Termination of Power and Control cables for the equipment under the scope of this specification. Bidders shall include all cable accessories like lugs, glands, cable tags, markers etc in their respective bids.
- iii) Earthing of all installations (to the nearest earth mat / earthing pad) supplied under the scope of this specification.

D. With Civil System

- i) Providing location of pipes crossing the road & trenches and laying of adequately sized Hume pipes.
- ii) Making RCC pedestals for above ground piping wherever required.

E. All machinery tools & tackles and consumables required for erection/testing / commissioning of the system shall be arranged by the Bidder.

F. Minor modifications, alterations in system installation as per customer's specific requirements shall be done without any extra cost to purchaser.

G. Bidders to ensure that sufficient quantity of spares are made available for timely completion of commissioning of the system. The bidder shall furnish a list of commissioning spares that will be brought by him. The unused commissioning spares shall be returnable to the bidder.

H. Obtaining approval from TAC/ TAC accredited agency on documents & installations.

- i) Obtaining, "As Built" certification from purchaser or owner on applicable drawings. Completing documentation as per specification requirement.
- ii) Obtaining customer's written acceptance of satisfactory completion of job. (Acceptance of PG + handing over of plant and mandatory spares (if any)).
- iii) Any other service not explicitly illustrated herein but which may be required to complete the system with its desired functionality or in the spirit of contract shall also deemed to be under the scope of bidder.

I. Civil Works

Civil Works Major civil works such as foundations, cut outs etc., shall be in Purchaser's scope. The Bidder shall however supply foundation bolts & hardware and undertake minor civil works such as grouting, filling up of crevices/ cut outs etc. Any damage caused to civil works during ETC work of the equipment/system shall have to be made good to the original finish by the Contractor at no extra cost to the Purchaser.

In addition the following shall be in the scope of Contractor:

- i) Laying of underground piping and construction of RCC pedestals to support the above ground piping for hydrant wherever required.
- ii) Construction of housing for deluge valve and painting the same on outside & inside. The housing shall have RCC roof.

4.5 MANDATORY SPARES

1	HVW Pumps		
1	Shaft Sleeves (for one pump)	Set	1
2	Gland Packing (for one pump)	Set	1
2	Diesel engine drive		
1	Self Starter assembly	No.	1
2	Lubricating oil filter elements (for one engine)	Set	1
3	Jockey Pumps		
1	Shaft Sleeves (for one pump)	Set	1
2	Gland Packing (for one pump)	Set	1
4	General		
1	Quartzoid bulb detector	No.	10% of total population
2	Projectors (Nozzles)	No.	10% of total population
3	Smoke detectors		
a)	Multisensor type	No.	20% of total population
4	Heat detectors	No.	10% of total population
5	Level switch	No.	1
6	Pressure switch	No.	1
7	Bronze pipe fitted with nozzle and guide coupling	No.	2
8	Hydrant valve	No.	1
9	Isolation valves	Set	1 no. for each type
10	Annunciation printed circuits (for solid state annunciation)	Set	1 no. for each type

4.6 TOOLS & TACKLES

Bidder shall include one set of standard tools and tackles required for maintenance of the system.
The list of tools required shall be furnished in the bid.

5.0 Exclusions

- a) Supply of power & control cables except for detection cable. However laying and termination of these cables shall be in contractor's scope. *The bidder shall furnish quantity and type of cables required complete system in their respective bids. Laying & termination is in contractor scope.*

- b) Supply of necessary cable trays for laying power and control cables, however hardware for fixing the same on wall trenches or elsewhere shall be included by the bidder in his bid.
- c) Supply of GI flat for earthing of equipments.
- d) Construction of equipment foundations inside the pump house. The contractor shall submit foundation details and supply foundation bolts etc. within one month of LOI.

6.0 UTILITIES AVAILABLE

Construction water and electricity shall be available at one point each. Contractor shall be required to make own arrangement for taking supplies from there.

7.0 OPERATION & MAINTENANCE (O&M) MANUAL

Operation and Maintenance manuals shall be specifically compiled for the project by the bidders. The draft O&M manual shall be submitted within 20 weeks after award of contract. The O&M manual shall contain the following information:

- a. Description of the system and equipment with design particulars.
- b. Instruction for erection.
- c. Instruction for operation, maintenance and repair.
- d. Recommended inspection practices and inspection schedule.
- e. Ordering information for all replaceable parts.
- f. Recommendation for type of lubricants and frequency of lubrication.

8.0 Handing & Taking Over

It is the responsibility of the contractor to maintain the plant till it is handed over. Any defect noted during the period shall be rectified by the contractor. Also suitable PG tests shall be conducted by the contractor to show the achievement of guaranteed parameters in line with the requirements of specification/ standards/ codes and to the satisfaction of Purchaser/ Owner.

10.0 Inspection & Testing

All the equipments shall be inspected prior to dispatch in line with relevant IS, approved GTP/ drawing and technical specification, BHEL/ customer approved QAP.

ANNEXURE- 'A'

CABLE SIZES BEING PROCURED BY BHEL FOR SUB-STATION

1.1	Power cables (XLPE) 1.1 kV
a	1C X 630 mm ²
b	3.5C X 300 mm ²
c	3.5C X 150 mm ²
d	1C X 150 mm ²
1.2	Power cables (PVC) 1.1 kV
a	3.5C X 70 mm ²
b	3.5C X 35 mm ²
c	4C X 16 mm ²
d	4C X 6 mm ²
e	2C X 6 mm ²
1.3	Control cable (PVC) 1.1 kV
a	2C X 2.5 mm ²
b	3C X 2.5 mm ²
c	5C X 2.5 mm ²
d	7C X 2.5 mm ²
e	10C X 2.5 mm ²
f	14C X 2.5 mm ²
g	19C X 2.5 mm ²
h	27C X 2.5 mm ²

SECTION - 2

EQUIPMENT SPECIFICATION

DESIGN AND CONSTRUCTION

2.01.00 Hydrant System

Hydrant system of fire protection essentially consists of a large network of pipe, both underground and over ground which feeds pressurised water to a number of hydrant valves, indoor (if applicable) as well as outdoor. These hydrant valves are located at strategic locations near buildings, Transformers and Reactors. Hose pipes of suitable length and fitted with standard accessories like branch pipes, nozzles etc., are kept in Hose boxes. In case of emergency, these hoses are coupled to the respective hydrant valves through instantaneous couplings and jet of water is directed on the equipment on fire. Hydrant protection shall be provided for the following in substations of voltage levels 400kV and above. At least one hydrant post shall be provided for every 60m of external wall measurement of buildings.

- a) Control room building
- b) L.T. Transformer area.
- c) Fire Fighting pump House.
- e) H.T Transformers

2.01.01 A warning plate shall be placed near the hydrant points for the transformers and reactors and the pump in substations to clearly indicate that water shall be sprayed only after ensuring that the power to the transformer/ reactor which is on fire is switched off and there are no live parts within 20metres of distance from the personnel using the hydrant.

2.02.00. HIGH VELOCITY WATER (H.V.W) SPRAY SYSTEM

H.V.W. spray type fire protection essentially consists of a network of projectors and an array of heat detectors around the Transformer/Reactor to be protected. On operation of one or more of heat detectors, Water under pressure is directed to the projector network through a Deluge valve from the pipe network laid for this system. This shall be provided for transformers and reactors in substations. Wet detection initiation system shall be employed for automatic operation.

The system shall be designed in such a way that the same can be extended to protect additional Transformer/ Reactor to be installed in future. However, for the purpose of design it shall be assumed that only one Transformer/ Reactor will be on fire.

2.02.01 The Electrical clearance between the Emulsifier system pipe work and live parts of the protected equipment shall not be less than the values given below:

- 1 765 kV bushing 4900 mm
- 2 420 kV bushing 3500 mm
- 3 245 kV bushing 2150 mm
- 4 145 kV bushing 1300 mm
- 5 52 kV bushing 630 mm
- 6 36 kV bushing 320 mm

2.02.02 System shall be designed in such a way that the Water pressure available at any spray nozzle shall be between 3.5bar and 5.0bar and shall be demonstrated through hydraulic calculations. Water shall be applied at a minimum rate of 10.2 LPM/M² of the surface area of the transformer / Reactor including radiator, conservator, oil pipes, bushing turrets, etc. (including bottom surface for transformer). The nozzle arrangement shall ensure direct impingement of water on all exterior surfaces of transformer tank, bushing turrets, conservator and oil pipes, except underneath the transformer, where horizontal spray may be provided.

2.02.03 **Deluge Valve**

Deluge Valve shall be water pressure operated manual reset type. The Deluge valve shall be closed water tight when water pressure in the heat detector pipe work is healthy and the entire pipe work shall be charged with water under pressure upto the inlet of the Deluge valve. On fall of water pressure due to opening of one or more heat detectors, the valve shall open and water shall rush to the spray water network through the open Deluge valve. The valves shall be manually reset to initial position after completion of operation. Each Deluge Valve shall be provided with a water motor gong which shall sound an alarm when water after passing through the Deluge valve, is tapped through the water motor.

Each Deluge valve shall be provided with a local panel with provision of opening of Deluge valve from local and remote from control room/ remote centre. In addition to this, each valve shall be provided with local operation latch.

Deluge valves of 100mmNB size shall be used if the flow requirement is $\leq 200\text{m}^3/\text{hr}$ and 150mmNB size shall be used for flow requirement $>200\text{m}^3/\text{hr}$.

2.02.04 **High Velocity Spray Nozzles (Projectors)**

High velocity spray system shall be designed and installed to discharge water in the form of a conical spray consisting of droplets of water travelling at high velocity, which shall strike the burning surface with sufficient impact to ensure the formation of an emulsion. At the same time the spray shall efficiently cut off oxygen supply and provide sufficient cooling.

2.02.05 Minimum set point of the heat detectors used in the HVW spray system shall be 79°C. The optimum rating shall, however, be selected by the Bidder, keeping in mind the maximum and minimum temperature attained at site.

2.03.00 Fire Detection and alarm System

This system shall be provided for control room building of substations.

2.03.01 Suitable fire detection system using smoke detectors and/or heat detectors shall be provided for the entire building, including corridor and toilets. Fire detectors shall be located at strategic locations in various rooms of the building. The operation of any of the fire detectors/ manual call point should result in the following;

1. A visual signal exhibited in the annunciation panels indicating the area where the fire is detected.
2. An audible alarm sounded in the panel, and
3. An external audible alarm sounded in the building, location of which shall be decided during detailed engineering.

2.03.03 Coverage area of each smoke detector shall as per rules of TAC. Multisensor detectors shall be provided in all areas except pantry room where heat detectors shall be provided. If a detector is concealed, a remote visual indication of its operation shall be provided. Manual call points (Break glass Alarm Stations) shall be provided at strategic locations in the control room building. All cabling shall be done through concealed conduits.

2.03.04 Cables used should be exclusively for fire detection and alarm system and shall be 2Cx1.5sq.mm Cu. cables. armoured PVC insulated FRLS cables shall be used.

2.04.00 Portable and Wheel/ Trolley mounted Fire Extinguishers

2.04.01 Portable Fire Extinguishers

Adequate number of portable fire extinguishers of pressurised water, dry chemical powder, and Carbon dioxide type shall be provided in suitable locations in control room building and FFPH building as indicated in the drawing. In addition to this one (1) CO₂ type fire extinguisher of 4.5kg capacity shall be provided for each Switchyard panel room. These extinguishers will be used during the early phases of fire to prevent its spread and costly damage.

2.05.00 Water Supply System

Water for hydrant & HVW system shall be supplied by one electrical motor driven pump of rated capacity 410m³/hr. at 70MWC head, with another pump of same capacity, driven by diesel engine, shall be used as standby. Water storage tank with two compartments of adequate capacity shall be provided. Pumps shall work under positive suction head. Annunciations of the hydrant & HVW spray systems shall be provided in fire water pump house and repeated in control room.

The outdoor piping for the system in general shall be laid above ground on concrete pedestals with proper supporting arrangement. However, at road/rail crossings, in front/access of buildings, places where movement of cranes/vehicles is expected and at any other place where above ground piping is not advisable, the pipes shall be laid underground. Such locations shall be finalized during detailed engineering.

The whole system will be kept pressurized by providing combination of air vessel and jockey pump of 10.8M³/hr. capacity at 80MWC. The capacity of air vessel shall not be less than 2m³. Minor leakage will be met by Jockey pump. One additional jockey pump shall be provided as standby. All pumps shall be of horizontal centrifugal type. Pumps and air vessel with all auxiliary equipment will be located in firewater pump house. A pressure relief valve of suitable rating shall be provided in water header to release excess pressure due to atmospheric temperature variations.

Operation of all the pumps shall be automatic and pumps shall be brought into operation at preset pressure. Fire pumps shall only be stopped manually. Manual start/stop provision shall be provided in local control panel.

2.05.01 Each pump shall be provided with a nameplate indicating suction lift/delivery head, capacity and number of revolutions per minute.

2.06.00 **Instrumentation and Control System**

2.06.01 All instruments like pressure indicators, differential pressure indicators, pressure switches, level indicators, level switches, temperature indicators, alarms and all other instruments and panels as indicated in the specification and drawings and those needed for safe and efficient operation of the whole system shall be furnished by Vendor as per customer requirement. Pump running/ fails to start signal shall be taken from the pressure switch immediately after the discharge of the pump.

2.06.02 **Control Panel**

Power feeder for motors will be from switchgear board located in control building but control supply for all local control panels, annunciation panels, battery charger units, space heaters etc. shall be fed from the AC and DC distribution boards located in pump house. These AC & DC distribution boards will be fed from the switchgears and DCDBs located in control building.

a) Panel for motor driven fire water pump

The panel shall be provided with the following:

- 1 TPN switch 1 No.
- 2 Auto/manual switch 1 No.
- 3 Start/Stop Push buttons 1 Set with indication lamp
- 4 DOL starter with 1 Set thermal O/L relay
- 5 Indicating lamp showing 1 Set power ON
- 6 Indication lamp with drive 1 Set ON/OFF
- 7 Indication lamp showing 1 No. Motor Trip

Main power cable from breaker feeder of main switchboard shall be terminated in this panel and another cable shall emanate from this panel which shall be terminated at motor terminals.

b) Panel for Two nos. Jockey Pump 1No.

The panel shall be provided with the following :

- 1 Fuse-switch unit for Jockey pumps 1 Set for each pump
- 2 Auto/manual switch for 1 No. for each pump
- 3 Selector switch for 1 No. selecting either jockey pump
- 4 D.O.L. starter with overload 1 No. each relay self-resetting type, for all the drives.
- 5 Start/stop push button for 1 Set for each pump Jockey Pump with indication lamp with pad-locking arrangements in stop position
- 6 Indication lamp for trip 1 No. each for pump indication

This panel shall be fed with power from switchgear boards in the control room

- c) Panel for 2 Nos. battery charger 1 No. & Diesel Engine driven fire water pump

The panel shall be provided with the following:

- 1 Auto/Manual switch for 1 No. Diesel Engine driven pump
- 2 Start/Stop push buttons 1 Set with indication lamp
- 3 Indicating lamp showing 1 Set drive ON/OFF
- 4 D.C. Voltmeter/Ammeter in 1 No. each the battery charger circuit
- 5 Battery charger will be as 1 Set per specification described
- 6 Selector switch for selecting 1 No. either of battery chargers for the battery sets.
- 7 Selector switch for selecting 1No. either set of batteries for Diesel engine starting.
- 8 Selector switch for boost 1 Set charging/Trickle charging of battery set.

This panel shall be fed with power from switchgear boards in the control room

- d) Individual local control panel is to be considered for each transformer/ Reactor deluge system wherever these equipment are envisaged. This panel shall contain push buttons with indicating lamps for spray ON/OFF operation in the valve operation circuit. Push buttons shall be concealed behind glass covers, which shall be broken to operate the buttons. Provision shall be made in the panel for the field signal for the annunciations such as spray ON and fire in the Transformer/Reactor. A signal for spray ON shall also be provided in the control room fire alarm panel for employer's event logger. Remote operation facility to open the Deluge valve from control room/ remote centre shall also be provided.

2.06.03 Annunciation Panels

a) Location: Fire Water Pump House

- i) Indicating lamps showing power supply "ON".
- ii) Annunciation windows complete with buttons. Details are as follows:
 - 1 Electric motor driven fire water pump running- 1 No.
 - 2 Electric motor driven fire water pump fails 1 to start
 - 3 Diesel engine driven fire water pump running. 1 No.
 - 4 Diesel engine driven water pump fails 1 to start
 - 5 Jockey pump-1 running 1 No.
 - 6 Jockey pump-1 fails to start 1 No.
 - 7 Jockey pump-2 running 1 No.

- 8 Jockey pump-2 fails to start 1 No.
- 9 Fire in Transformer/ Reactor 1 for each equipment
- 10 Deluge system operating for 1 for each Transformer/Reactor equipment
- 11 Header pressure low 1 No.
- 12 Fire in smoke detection system zone 1 (Common Fire Signal)
- 13 Water storage tank water level low 2 Nos.
14. High speed diesel tank level low 1 No.
- 14 Spare

b) Location: Control Room

i) Indication lamp showing power supply 'ON'

ii) Provision shall be made in the panel for a signal for spray ON for each Transformer/Reactor for owner's use for event logger.

iii) Following annunciations shall be provided.

- 1 Fire in Transformer/ Reactor 1 for each equipment
- 2 Diesel engine driven fire water 1 pump in operation
- 3 Motor driven fire water pump in operation 1
- 4 Jockey pump in operation 1
- 5 Fire fighting Water storage tank level Low 2
- 6 Spare windows complete in all 10 respect, with relays

c) Each annunciation panel shall be provided with a hooter.

d) Indication for fault in respective areas shall also be provided. Each zone alarm module shall exhibit 'FIRE' and 'FAULT' conditions separately.

2.06.04 The control and interlock system for the fire protection system shall meet the following requirements:

1. Electric Motor Driven Fire water Pump

Pump should start automatically when the System header pressure is low.

Pump should be stopped manually only. Pump should also be started manually if required from local control panel.

2. Diesel Engine Driven Standby Pump

The pump should automatically start under any of the following conditions:

- a) System Header pressure low.
- b) Electric motor operated fire water pump fails to start.

Pump should be stopped manually only. Pump should also be started manually if required

from the local control panel. The battery set which is connected for starting of Diesel engine shall not be subjected to boost charge.

3. Jockey Pump

It shall be possible to select any one of the Jockey pumps as main and the other as standby. Main Jockey pump shall start automatically when water pressure in header falls below the set value. If the main jockey pump fails to start then the standby should start. Jockey pump shall stop automatically when the pressure is restored to its normal value.

Manual starting/stopping shall be possible from the local control panel.

3.00.00 TESTS

3.01.00 Shop Tests

3.01.01 Shop tests of all major equipment centrifugal pumps, diesel engines, electrical drive motors, piping, valves and specialties, pressure and storage vessels, MCC, electrical panels, controls, instrumentation etc. shall be conducted as specified in various clauses and as per applicable standards/ codes.

3.01.02 Shop tests shall include all tests to be carried out at Contractor's works, works of his sub-contractor and at works where raw materials supplied for manufacture of equipment are fabricated. The tests to be carried out shall include but not be limited to the tests described as follows:
a) Materials analysis and testing. b) Hydrostatic pressure test of all pressure parts, piping, etc. c) Dimensional and visual check. d) Balancing test of rotating components. e) Response of heat/smoke detectors. f) Performance characteristics of HVW spray nozzles (projectors). g) Flow rate and operational test on Flow control valves. h) Operational test of alarm valve (water-motor gang). i) Calibration tests on instruments and tests on control panel. j) Destruction/burst tests on 2% or minimum one (1) no. of hoses and portable type fire extinguishers for each type as applicable. Any fraction number shall be counted as next higher integer. k) Performance test on fire extinguishers as required in the code.

3.01.03 In the absence of any Code/Standard, equipment shall be tested as per mutually agreed procedure between the supplier and the Employer.

3.01.04 A comprehensive visual and functional check for panels would be conducted and will include a thorough check up of panel dimensions, material of construction, panel finish, compliance with tubing and wiring specifications, quality of workmanship, proper tagging & locations of instruments/accessories. The wiring check shall be complete point to point ring out and check for agreement with installation drawings and equipment vendor prints of the complete system and an inspection of all field connection terminals and levelling.

3.01.05 All test certificates and reports shall be submitted to the Employer for approval.

3.01.06 The Employer's representative shall be given full access to all tests. The manufacturer shall inform the Employer allowing adequate time so that, if the Employer so desires, his representatives can witness the test.

3.02.00 **Pre-commissioning Tests**

3.02.01 **General**

- a) All piping and valves, after installation will be tested hydraulically at a pressure of 16kg/cm^2 for a period of 30 minutes to check against leak tightness.
- b) All manually operated valves/gates shall be operated throughout 100% of the travel and these should function without any trouble whatsoever, to the satisfaction of the Employer.
- c) All pumps shall be run with the specified fluid from shut off condition to valve wide open condition. Head developed will be checked from the discharge pressure gauge reading. During the test, the pumps and drives shall run smoothly without any undue vibration, leakage through gland, temperature rise in the bearing parts, noise, flow pulsation etc.
- d) All pressure vessels should be tested hydraulically at the specified test pressure, singly or in the system.
- e) Painting shall be checked by dry type thickness gauges.
- f) Visual check on all structural components, welding, painting etc. and if doubt arises, these will be tested again.
- g) All test instruments and equipment shall be furnished by the Contractor to the satisfaction of the Employer.
- h) Automatic starting of all the fire pumps by operating the test valves.
- i) Automatic operation of the Jockey pump
- j) Operation of the Deluge valve by breaking a detector as well as manual and remote operation of the deluge valve.
- k) Operation of entire annunciation system.

Replacement of fused/damaged quartzoid bulb detectors during the test shall be responsibility of contractor.

3.02.02 After erection at site, the complete HVW spray protection and hydrant system shall be subject to tests to show satisfactory performance for which detailed procedure shall be submitted for Employer's approval.

Full flow tests with water shall be done for the system piping as a means of checking the nozzle layout, discharge pattern and coverage, any obstructions and determination of relation between design criteria and actual performance, also to ensure against clogging of the smaller piping and the discharge devices by foreign matter carried by the water.

Rigidity of pipe supports shall also be checked during the water flow.

All the detectors installed shall be tested for actuation by bringing a suitable source of heat/smoke near the detector and creating a stream of hot air/ smoke over the detector. The exact procedure of this test shall be detailed out by the Employer to the successful Bidder.

5.00.00 HORIZONTAL CENTRIFUGAL PUMPS

This clause covers the design, performance, manufacturing, construction features and testing of horizontal centrifugal pumps used for the purpose of fire fighting.

5.01.00 The materials of the various components shall conform to the applicable IS/BS/ASTM/DIN Standards.

5.01.01 In case of any contradiction with the aforesaid standards and the stipulations as per the technical specification as specified hereinafter, the stipulations of the technical specification shall prevail.

5.02.00 General Performance Requirements

5.02.01 The pump set shall be suitable for continuous operation at any point within the "Range of operation".

5.02.02 Pumps shall have a continuously rising head capacity characteristics from the specified duty point towards shut off point, the maximum being at shut off.

5.02.03 Pumps shall be capable of furnishing not less than 150% of rated capacity at a head of not less than 65% of the rated head. The shut off head shall not exceed 120% of rated head. Range of operation shall be 20% of rated flow to 150% of rated flow.

5.02.04 The pump-motor set shall be designed in such a way that there is no damage due to the reverse flow through the pump which may occur due to any mal-operation of the system.

5.02.05 Drive Rating

The drive rating shall not be less than the maximum power requirement at any point within the "Range of Operation" specified.

During starting under reverse flow condition, the motor shall be capable of bringing the pump to rated speed at normal direction with 90% rated voltage at motor terminals.

5.02.06 Pump set along with its drive shall run smooth without undue noise and vibration. Acceptable peak to peak vibration limits shall generally be guided by Hydraulic Institute Standards.

5.02.07 The Contractor under this specification shall assume full responsibility in the operation of the pump and drive as one unit.

5.03.00 Design & Construction

5.03.01 Pump casing may be axially or radially split. The casing shall be designed to withstand the maximum pressure developed by the pump at the pumping temperature.

5.03.02 Pump casing shall be provided with adequate number of vent and priming connections with valves, unless the pump is made self-venting & priming. Casing drain, as required, shall be provided complete with drain valves.

5.03.03 Under certain conditions, the pump casing nozzles will be subjected to reactions from external piping. Pump design must ensure that the nozzles are capable of withstanding external reactions not less than those specified in API-610.

5.03.04 Pump shall preferably be of such construction that it is possible to service the internals of the pump without disturbing suction and discharge piping connections.

5.03.05 Impeller

The impeller shall be secured to the shaft and shall be retained against circumferential movement by keying, pinning or lock rings. On pumps with overhung shaft impellers shall be secured to the shaft by an additional locknut or cap screw. All screwed fasteners shall tighten in the direction of normal rotation.

5.03.06 Wearing Rings

Replaceable type wearing rings shall be furnished to prevent damage to impeller and casing. Suitable method of locking the wearing ring shall be used.

5.03.07 Shaft

Shaft size selected shall take into consideration the critical speed, which shall be at least 20% away from the operating speed. The critical speed shall also be atleast 10% away from runaway speed.

5.03.08 Shaft Sleeves

Renewable type fine finished shaft sleeves shall be provided at the stuffing boxes/mechanical seals. Length of the shaft sleeves must extend beyond the outer faces of gland packing or seal and plate so as to distinguish between the leakage between shaft & shaft sleeve and that past the seals/gland.

5.03.09 Shaft sleeves shall be securely fastened to the shaft to prevent any leakage or loosening. Shaft and shaft sleeve assembly should ensure concentric rotation.

5.03.10 Bearings

Bearings of adequate design shall be furnished for taking the entire pump load arising from all probable conditions of continuous operation throughout its "Range of Operation" and also at the shut-off condition. The bearing shall be designed on the basis of 20,000 working hours minimum for the load corresponding to the duty point.

Bearings shall be easily accessible without disturbing the pump assembly. A drain plug shall be provided at the bottom of each bearing housing.

5.03.11 **Stuffing Boxes**

Stuffing box design shall permit replacement of packing without removing any part other than the gland. Stuffing boxes shall be sealed/cooled by the fluid being pumped and necessary piping, fittings, valves, instruments, etc. shall form an integral part of the pump assembly.

5.03.12 **Shaft Couplings**

All shafts shall be connected with adequately sized flexible couplings of suitable design. Necessary guards shall be provided for the couplings.

5.03.13 **Base Plates & Sole Plate**

A common base plate mounting both for the pump and drive shall be furnished.

The base plate shall be of rigid construction, suitably ribbed and reinforced. Base plate and pump supports shall be so constructed and the pumping unit so mounted as to minimize misalignment caused by mechanical forces such as normal piping strain, hydraulic piping thrust etc. Suitable drain taps and drip lip shall be provided.

5.03.14 **Material of Construction**

All materials used for pump construction shall be of tested quality. Material of construction of the major parts of the pumps shall be as given below:

- a) Casing
- b) Impeller
- c) Wearing ring
- d) Shaft
- e) Shaft sleeve
- f) Stuffing box
- g) Gland

5.03.15 **Balancing**

All rotating components shall be statically and dynamically Casting Grade FG: 260 of IS 210 Bronze Grade LTB 2 of IS: 318 Bronze Grade LTB 2 of IS: 318 Grade 40C8 of IS 1570 (Part 2, section 1.): 1979. Bronze Grade LTB 2 of IS: 318 or Chrome steel 07Cr13 of IS 1570 (part 5):1985. 2.5% Nickel CI Grade FG 260 of IS:210 ---do --

balanced at shop.

5.03.16 All the components of pumps of identical parameters supplied under this specification shall be interchangeable.

5.04.00 **Tests and Inspection**

5.04.01 The manufacturer shall conduct all routine tests required to ensure that the equipment furnished conform to the requirements of this specification and are in compliance with the requirements of applicable Codes and Standards. The particulars of the proposed tests and the procedures for the tests shall be submitted to the Employer/Engineer for approval before conducting the tests.

5.04.02 Where stage inspection is to be witnessed by Employer, in addition to above, the Bidder shall submit to the Employer/Engineer at the beginning of the contract, the detailed PERT-Chart showing the manufacturing programme and indicating the period where Employer is authorized inspecting agency are required at the shop.

5.04.03 Material of Construction

All materials used for pump construction shall be of tested quality. Materials shall be tested as per the relevant standards and test certificates shall be made available to the Employer/Engineer.

5.04.04 Where stage inspection is to be witnessed by Employer, all material test certificates shall be correlated and verified with the actual material used for construction before starting fabrication, by Employer's Inspector who shall stamp the material. In case mill test certificates for the material are not available, the Contractor shall carry out physical and chemical tests at his own cost from a testing agency approved by the Employer, as per the requirements of specified material standard. The samples for physical and chemical tests shall be drawn up in presence of Employer's inspector who shall also witness the tests.

5.04.05 Shaft shall be subjected to 100% ultrasonic test and machined portion of the impeller shall be subject to 100% DP test. On finished shaft DP test will also be carried out.

5.04.06 Hydraulic test at shop

All pressure parts shall be subjected to hydraulic testing at a pressure of 150% of maximum pressure generated by the pump at rated speed or 200% of total dynamic head whichever is higher, for a period not less than one (1) hour.

5.04.07 Performance test at shop

Pumps shall be subjected to routine tests to determine the performance of the pumps. These tests shall be conducted in presence of Employer/Engineer's representative as per the requirements of the Hydraulic Institute Standards/ASME Power Test Code PTC 8.2/BS- 599/I.S.S., latest edition. Routine tests shall be done on all the pumps.

5.04.08 Performance tests shall be conducted to cover the entire range of operation of the pumps. These shall be carried out to span 150% of rated capacity upto pump shut-off condition. A minimum of five combinations of head and capacity are to be achieved during testing to establish the performance curves, including the design capacity point and the two extremities of the Range of operation specified.

5.04.09 Tests shall preferably be conducted alongwith the actual drives being supplied.

5.04.10 The Bidders shall submit in his proposal the facilities available at his works to

conduct performance testing. If because of limitations of available facilities, a reduced speed test or model test has to be resorted to establish pump performance, the same has to be highlighted in the offer.

- 5.04.11 In case of model testing, the stipulations of latest edition of Hydraulic Institute Standards shall be binding. Prototype or model tests, however, shall be conducted with the suction condition identical to the field conditions i.e. sigma values of prototype and model is to be kept same.
- 5.04.12 Prior to conducting model testing, calculations establishing model parameters, sizes and test procedure will be submitted to Employer/Engineer for approval.
- 5.04.13 All rotating components of the pumps shall be subjected to static and dynamic balancing tests.
- 5.04.14 The Employer or his authorised representative shall have full access to all tests. Prior to performance tests, the Contractor shall intimate the Employer allowing adequate time so that if the Employer so desires, his representative can witness the test.
- 5.04.15 Report and test certificates of the above tests shall be submitted to the Employer/Engineer for approval.
- 5.04.16 **Pre commissioning tests.**

After installation, pumps offered may be subjected to testing at field also by Employer. If the performances at field are not found to meet the requirement, then the equipment shall be rectified by the Contractor without any extra cost. Prior to performance testing, the procedure for such tests will be mutually agreed between Employer and Contractor. The Contractor shall furnish all necessary instruments, accessories and personnel for testing. Prior to testing, the calibration curves of all instruments and permissible tolerance limit of instruments shall be mutually agreed upon.

6.00.00 **DIESEL ENGINES**

This Clause covers the design, performance, manufacturing construction features and testing of compression ignition diesel engines, used primarily for driving centrifugal pumps, used for the purpose of firefighting.

6.01.00 **Design and Construction** **General**

- 6.01.01 The diesel engine shall be of multicylinder type four-stroke cycle with mechanical (airless) injection, cold starting type.
- 6.01.02 The continuous engine brake horse power rating (after accounting for all auxiliary power consumption) at the site conditions shall be atleast 20% greater than the requirement at the duty point of pump at rated RPM and in no case, less than the maximum power requirement at any condition of operation of pump.
- 6.01.03 Reference conditions for rated output of engine shall be as per IS: 10000, part II or

ISO: 3046, part I.

6.01.04 The engine shall be designed with regard to ease of maintenance, repair, cleaning and inspection.

6.01.05 All parts subjected to substantial temperature changes shall be designed and supported to permit free expansion and contraction without resulting in leakage, harmful distortion or misalignment.

6.01.06 **Starting**

The engine shall be capable of both automatic and manual start. The normal mode of starting is automatic but in the event of failure of automatic start or at the discretion of the operator, the engine can be started manually from the LCP.

Since the fire pumping unit driven by the diesel engine is not required to run continuously for long periods and the operation will not be frequent, features shall be built into the engine to allow it to start within a very short period against full load even if it has remained idle for a considerable period.

6.01.07 If provision for manual start (cranking) is provided, all controls/mechanisms, which have to be operated during the starting process, shall be within easy reach of the operator.

6.01.08 Automatic cranking shall be effected by a D.C. motor having high starting torque to overcome full engine compression. Starting power will be supplied from either of the two (2) sets of storage batteries. The automatic starting arrangement shall include a 'Repeat Start' feature for 3 attempts. The battery capacity shall be adequate for 3 (three) consecutive starts without recharging with a cold engine under full compression.

6.01.09 The batteries shall be used exclusively for starting the diesel engine and be kept fully charged all the time in position. Arrangement for both trickle and booster charge shall be provided.

Diesel engine shall be provided with two (2) battery charger units of air-cooled design. The charger unit shall be capable of charging one (1) set of battery at a time. Provision shall, however, be made so that any one of the charger units can be utilised for charging either of the two (2) batteries.

6.01.10 For detail design of battery and battery charger, sub-section Electrical may be referred to.

6.01.11 **Governing System:**

The engine shall be fitted with a speed control device, which will control the speed under all conditions of load.

6.01.12 The governor shall offer following features:

- a) Engine should be provided with an adjustable governor capable of regulating engine speed within 5% of its rated speed under any condition of load between shut-off and maximum load conditions of the pumps. The

governor shall be set to maintain rated pump speed at maximum pump load.

- b) Engine shall be provided with an over speed shut- down device. It shall be arranged to shut-down the engine at a speed approximately 20% above rated engine speed and for manual reset, such that the automatic engine controller will continue to show an over speed signal until the device is manually reset to normal operating position (Vol.II , NFPA, 1978).

6.01.13 The governor shall be suitable for operation without external power supply.

6.01.14 **Fuel System**

The diesel engine will run on High Speed Diesel.

6.01.15 The engine shall be provided with fuel oil tank of 250 litres capacity. The fuel oil tank shall preferably be mounted near the engine. No fuel oil tank will be provided by the Employer.

6.01.16 The fuel oil tank shall be of welded steel constructed to relevant standards for mild steel drums. The outlet of the tank shall be above the inlet of fuel injection pump of the diesel engine to ensure adequate pressure at suction of injection pump.

6.01.17 The fuel oil tank shall be designed in such a way that the sludge and sediment settles down to the tank bottom and is not carried to the injection pump. A small sump shall be provided and fitted with drain plug to take out sludge/sediment and to drain oil. Adequate hand holes (greater than 80 mm size) shall be provided to facilitate maintenance.

6.01.18 Pipeline carrying fuel oil shall be gradually sloped from the tank to the injection pump. Any valve in the fuel feed pipe between the fuel tank and the engine shall be placed adjacent to the tank and it shall be locked in the open position. A filter shall be incorporated in this pipeline, in addition to other filters in the fuel oil system. Pipe joints shall not be soldered and plastic tubing shall not be used. Reinforced flexible pipes may also be used.

6.01.19 The complete fuel oil system shall be designed to avoid any air pocket in any part of the pipe work, fuel pump, sprayers/injectors, filter system etc. No air relief cock is permitted. However, where air relief is essential, plugs may be used.

6.01.20 A manual fuel pump shall be provided for priming and releasing of air from the fuel pipelines.

6.01.21 **Lubricating Oil System**

Automatic pressure lubrication shall be provided by a pump driven by the crank shaft, taking suction from a sump and delivering pressurized oil through cooler and fine mesh filters to a main supply header fitted in the bed plate casing. High pressure oil shall be supplied to the main and big end bearings, cam-shaft bearings, cam-shaft chain and gear drives, governor, auxiliary drive gears etc. Valve gear shall be lubricated at reduced pressure through a reducing valve and the cams by an oil bath.

6.01.22 Cooling Water System

Direct cooling or heat exchanger type cooling system shall be employed for the diesel engine. Water shall be tapped from the fire pump discharge. This water shall be led through duplex strainer, pressure breakdown orifice and then after passing through the engine, the water at the outlet shall be taken directly to the sump through an elevated funnel.

6.02.00 Testing & Inspection

6.02.01 The manufacturer shall conduct all tests required, to ensure that the equipment furnished conforms to the requirement of this sub-section and in compliance with requirements of applicable codes. The particulars of the proposed tests and the procedure for the tests shall be submitted to the Employer for approval before conducting the tests.

6.02.02 At manufacturer's works, tests shall be carried out during and after completion of manufacture of different component/parts and the assembly as applicable. Following tests shall be conducted.

6.02.03 Material analysis and testing.

6.02.04 Hydrostatic pressure testing of all pressure parts.

6.02.05 Static and dynamic balance tests of rotating parts at applicable over-speed and determination of vibration level.

6.02.06 MPI/DPT on machined parts of piston and cylinder.

6.02.07 Ultrasonic testing of crankshaft and connecting rod after heat treatment.

6.02.08 Dimensional check of close tolerance components like piston, cylinder bore etc.

6.02.09 Calibration tests of all fuel pumps, injectors, standard orifices, nozzles, instruments etc.

6.02.10 Over speed test of the assembly at 120% of rated speed.

6.02.11 Power run test.

6.02.12 Performance test of the diesel engine to determine its torque, power and specific fuel consumption as function of shaft speed. Performance test of the engine shall be carried for 12 hours out of which 1 hour at full load and one hour at 110% overload.

6.02.13 Measurement of vibration & noise.

(i) Measurement of vibration

The vibration shall be measured during full load test as well as during the overload test and limit shall be 100 microns.

(ii) Measurement of noise level

The equivalent 'A' weighted sound level measured at a distance of 1.5 M above

floor level in elevation and 1.0 M horizontally from the base of the equipment, expressed in dB to a reference of 0.0002 microbar shall not exceed 93 dBA.

Above tests for vibration shall be repeated at site as pre-commissioning tests.

6.02.14 Adjustment of speed governor as per BS: 5514.

- 1 Diesel engine shall be subjected to routine tests as per IS: 10000/BS: 5514.
- 2 PIPING, VALVES AND SPECIALITIES

This clause covers the design, manufacture, shop testing, erection, testing and commissioning of piping, valves and specialities.

7.02.00 **Scope**

The piping system which shall include but not be limited to the following:

- 7.02.01 Plain run of piping, bends, elbows, tees, branches, laterals, crosses, reducing unions, couplings, caps, expansion joints, flanges, blank flanges, thrust blocks, anchors, hangers, supports, saddles, shoes, vibration dampeners, sampling connections, hume pipes etc.
- 7.02.02 Gaskets, ring joints, backing rings, jointing material etc. as required. Also all welding electrodes and welding consumables including special ones, if any.
- 7.02.03 Instrument tapping connections, stubs etc.
- 7.02.04 Gate and globe valves to start/stop and regulate flow and swing check valves for one directional flow.
- 7.02.05 Basket strainers and Y-type strainers
- 7.02.06 Bolts, nuts, fasteners as required for interconnecting piping, valves and fittings as well as for terminal points. For pipe connections into Owner's R.C.C. works, Bidder will furnish all inserts.
- 7.02.07 Painting, anti-corrosive coatings etc. of pipes and equipment.

Adequate number of air release valves shall be provided at the highest points in the piping system to vent any trapped air in the system.

7.03.00 **Design**

7.03.01 Material of construction of various pipes shall be as follows :

(a) **Buried Pipes**

Mild steel black pipes as per IS: 1239, Part-I medium grade (for pipes of sizes 150 NB and below) or IS:3589, Fe 410 grade (for pipes of sizes 200 NB and above) suitably lagged on the outside to prevent soil corrosion, as specified elsewhere.

(b) Overground Pipes normally full of water

Mild steel black pipes as per IS: 1239, Part-I medium grade (for pipes for sizes 150 NB and below) or IS:3589, Fe 410 grade (for pipes of sizes 200 NB and above).

(c) Overground pipes normally empty, but periodic charge of water and for detector line for HVW System.

Mild steel galvanised pipes as per IS:1239, Part-I medium grade (for pipes of sizes 150 NB and below) or IS:3589, Fe 410 grade (for pipes of sizes 200 NB and above).

- 7.03.02 All fittings to be used in connection with steel pipe lines upto a size of 80 mm shall be as per IS:1239. Part-II Mild steel tubulars and other wrought steel pipe fittings, Heavy grade. Fittings with sizes above 80mm upto 150 mm shall be fabricated from IS:1239 Heavy grade pipes or steel plates having thickness not less than those of IS:1239 Part-I Heavy grade pipes. Fittings with sizes above 150 mm shall be fabricated from IS:3589 Class-2 pipes. All fitting used in GI piping shall be threaded type. Welding shall not be permitted on GI piping.
- 7.03.03 Pipe sizes shall not be less than the sizes indicated in the attached drawings.
- 7.03.04 For steel pipeline, welded construction should be adopted unless specified otherwise.
- 7.03.06 All piping system shall be capable of withstanding the maximum pressure arising from any condition of operation and testing including water hammer effects.
- 7.03.09 Gate/sluice valve shall be used for isolation of flow in pipe lines and shall be as per 778 (for size upto 40 mm) and IS: 14846 (for sizes above 40 mm). Valves shall be of rising spindle type and of PN 1.6 class
- 7.03.10 Gate Valves shall be provided with the following:
- (a) Hand wheel.
 - (b) Position indicator.
 - (c) Locking facility (where necessary).
- 7.03.11 Gate valves shall be provided with back seating bush to facilitate gland removal during full open condition.
- 7.03.12 Globe valves shall be provided with contoured plug to facilitate regulation and control of flow. All other requirements should generally follow those of gate valve.
- 7.03.13 Non-return valves shall be swing check type. Valves will have a permanent "arrow" inscription on its body to indicate direction of flow of the fluid. These valves shall generally conform to IS: 5312.
- 7.03.14 Whenever any valve is found to be so located that it cannot be approached manually from the nearest floor/gallery/platform hand wheel with floor stand or chain operator shall be provided for the same.
- 7.03.15 Valves below 50 mm size shall have screwed ends while those of 50 mm and

higher sizes shall have flanged connections.

7.03.14 **Basket Strainer**

- a) Basket strainers shall be of 30 mesh and have the following materials of construction:

Body: Fabricated mild steel as per IS: 2062 (Tested Quality). Strainer Wires: stainless steel (AISI: 316), 30 SWG, suitably reinforced.

- b) Inside of basket body shall be protected by two (2) coats of heavy duty bitumastic paint.
- c) Strainers shall be Simplex design. Suitable vent and drain connections with valves shall be provided.
- d) Screen open area shall be at least 4 times pipe cross sectional area at inlet.
- e) Pressure drop across strainer in clean condition shall not exceed 1.5 MWC at 410 M³/hr flow. Pressure drop test report of strainer of same design shall be furnished.

7.03.15 **Y-type On-line Strainer**

Body shall be constructed of mild steel as per IS: 2062 (tested quality). Strainer wires shall be of stainless steel AISI: 316, 30 SWG, 30 mesh.

Blowing arrangement shall be provided with removable plug at the outlet. Screen open area shall be at least 4 times pipe cross-sectional area at inlet.

Pressure drop test report of strainer of same design shall be furnished.

7.03.16 **Hydrant Valve (Outdoor) and Indoor Hydrant Valves (Internal Landing Valves).**

The general arrangement of outdoor stand post assembly, consisting of a column pipe and a hydrant valve with a quick coupling end shall be as per TAC requirement.

Materials of construction shall be as follows: a) Column pipe M.S. IS: 1239 med. grade. b) Hydrant Valve

- i) Body Gun metal.
- ii) Trim Leaded tin bronze as per IS: 318, Grade-LTB 2.
- iii) Hand Wheel Cast Iron as per IS: 210, Grade FG:200.
- iv) Washer, gasket, etc. Rubber as per IS: 638.
- v) Quick coupling Leaded tin bronze as per connection IS: 318, Grade-LTB 2.
- vi) Spring Phosphor Bronze as per IS: 7608.
- vii) Cap and chain Leaded tin bronze as per IS: 318, Grade-LTB etc.2.

The general design of hydrant valve shall conform to IS: 5290.

7.03.17 Hoses, Nozzles, Branch pipes and Hose boxes

- a) Hose pipes shall be of reinforced rubber-lined canvas construction as per type A of IS: 636 with nominal size of 63 MM (2 1/2") and lengths of 15 metre or 7.5 metre, as indicated elsewhere. All hoses shall be ISI marked.
- b) Hosepipes shall be capable of withstanding an internal water pressure of not less than 35.7 kg/cm² without bursting. It must also withstand a working pressure of 8.5 kg/cm² without undue leakage or sweating.
- c) Each hose shall be fitted with instantaneous spring lock type couplings at both ends. Hose shall be fixed to the coupling ends by copper rivets and the joint shall be reinforced by 1.5 mm galvanized mild steel wires and leather bands.
- d) Branch pipes shall be constructed of copper and have rings of leaded tin bronze (as per IS: 318 Grade-2) at both ends. One end of the branch pipe will receive the quick coupling while the nozzles will be fixed to the other end.
- e) Nozzles shall be constructed of leaded tin bronze as per IS: 318, Grade-2.
- f) Suitable spanners of approved design shall be provided in adequate numbers for easy assembly and dismantling of various components like branch pipes, nozzles, quick coupling ends etc.
- g) Hose pipes fitted with quick coupling ends, branch pipes, nozzles spanner etc. will be kept in a hose box, which will be located near point of use. The furnished design must meet the approval of Tariff Advisory Committee.
- h) All instantaneous couplings, as mentioned under clause Nos.3.03.19, 3.03.20 and 3.03.21 above shall be of identical design (both male and female) so that anyone can be interchanged with another. One male, female combination shall get locked in by mere pushing of the two halves together but will provide leak tightness at a pressure of 8 kg/cm² of water. Designs employing screwing or turning to have engagement shall not be accepted.

7.04.00 Fabrication & Erection

7.04.01 The contractor shall fabricate all the pipe work strictly in accordance with the related approved drawings.

7.04.02 End Preparation

- (a) For steel pipes, end preparation for butt welding shall be done by machining.
- (b) Socket weld end preparation shall be sawing/machining.
- (c) For tees, laterals, mitre bends, and other irregular details cutting templates shall be used for accurate cut.

7.04.03 Pipe Joints

- (a) In general, pipes having sizes over 25 mm shall be joined by butt welding. Pipes having 25 mm size or less shall be joined by socket welding/screwed connections. Galvanised pipes of all sizes shall have screwed joints. No welding shall be permitted on GI pipes. Screwed joints shall have tapered threads and shall be assured of leak tightness without using any sealing compound.
- (b) Flanged joints shall be used for connections to vessels, equipment, flanged valves and also on suitable straight lengths of pipe line of strategic points to facilitate

erection and subsequent maintenance work.

7.04.04 **Overground Piping**

- (a) Piping to be laid overground shall be supported on pipe rack/supports. Rack/supports details shall have to be approved by Employer/Engineer.
- (b) Surface of overground pipes shall be thoroughly cleaned of mill scale, rust etc. by wire brushing. Thereafter one (1) coat of red lead primer shall be applied. Finally two (2) coats of synthetic enamel paint.

7.04.05 **Buried Pipe Lines**

- (a) Pipes to be buried underground shall be provided with protection against soil corrosion by coating and wrapping with two coats of coal tar hot enamel paint and two wraps of reinforced fibre glass tissue. The total thickness of coating and wrapping shall not be less than 3 mm. Alternatively corrosion resistant tapes can also be used for protection of pipes against corrosion.
- (b) Coating and wrapping and holiday testing shall be in line with IS: 10221.
- (c) Buried pipelines shall be laid with the top of pipe one meter below ground level.
- (d) At site, during erection, all coated and wrapped pipes shall be tested with an approved Holiday detector equipment with a positive signalling device to indicate any fault hole breaks or conductive particle in the protective coating.

7.05.00 **General Instruction for Piping Design and Construction**

7.05.01 While erecting field run pipes, the contractor shall check, the accessibility of valves, instrument tapping points, and maintain minimum headroom requirement and other necessary clearance from the adjoining work areas.

7.05.02 Modification of prefabricated pipes, if any, shall have to be carried out by the contractor at no extra charge to the Employer.

7.05.03 **Welding**

- (i) Welding shall be done by qualified welders only.
- (ii) Before welding, the ends shall be cleaned by wire brushing, filing or machine grinding. Each weld-run shall be cleaned of slag before the next run is deposited.
- (iii) Welding at any joint shall be completed uninterrupted. If this cannot be followed for some reason, the weld shall be insulated for slow and uniform cooling.
- (iv) Welding shall be done by manual oxyacetylene or manual shielded metal arc process. Automatic or semi-automatic welding processes may be done only with the specific approval of Employer/ Consultant.
- (v) As far as possible welding shall be carried out in flat position. If not possible, welding shall be done in a position as close to flat position as possible.
- (vi) No backing ring shall be used for circumferential butt welds.
- (vii) Welding carried out in ambient temperature of 5°C or below shall be heat-treated.

- (viii) Tack welding for the alignment of pipe joints shall be done only by qualified welders. Since tack welds form part of final welding, they shall be executed carefully and shall be free from defects. Defective welds shall be removed prior to the welding of joints.

Electrodes size for tack welding shall be selected depending upon the root opening.

- (ix) Tacks should be equally spaced as follows:

for 65 NB and smaller pipes : 2 tacks

for 80 NB to 300 NB pipes : 4 tacks

for 350 NB and larger pipes : 6 tacks

- (x) Root run shall be made with respective electrodes/filler wires. The size of the electrodes/filler wires. The size of the electrodes shall not be greater than 3.25 mm (10 SWG) and should preferably be 2.3 mm (12 SWG). Welding shall be done with direct current values recommended by the electrode manufacturers.

- (xi) Upward technique shall be adopted for welding pipes in horizontally fixed position. For pipes with wall thickness less than 3mm, oxyacetylene welding is recommended.

- (xii) The root run of butt joints shall be such as to achieve full penetration with the complete fusion of root edges. The weld projection shall not exceed 3 mm inside the pipe.

- (xiii) On completion of each run craters, weld irregularities, slag etc. shall be removed by grinding or chipping.

- (xiv) Fillet welds shall be made by shielded metal arc process regardless of thickness and class of piping. Electrode size shall not exceed 10 SWG. (3.25 mm). At least two runs shall be made on socket weld joints.

7.06.00 Tests at Works

7.06.01 Pipes

- (i) Mechanical and chemical tests shall be performed as required in the codes/standards.
- (ii) All pipes shall be subjected to hydrostatic tests as required in the codes/standards.
- (iii) 10% spot Radiography test on welds of buried pipes shall be carried out as per ASME VIII.

7.06.02 Valves

- (i) Mechanical and chemical tests shall be conducted on materials of the valve as required in the codes/standards.
- (ii) All valves shall be tested hydrostatically for the seat as well as required in the code/standards for a period of ten minutes.
- (iii) Air test shall be conducted to detect seat leakage.
- (iv) Visual check on the valve and simple operational test in which the valve will be operated thrice from full open to full close condition.
- (v) No repair work on CI valve body, bonnet or wedge shall be allowed.

7.06.03 **Strainers**

- (i) Mechanical and chemical tests shall be conducted on materials of the strainer.
- (ii) Strainers shall be subjected to a hydrostatic test pressure of 1.5 times the design pressure or 10 kg/cm²g whichever is higher for a period of one hour.

7.06.04 **Hydrant valves and Indoor Hydrant Valves (Internal Landing Valves)**

- (i) The stand post assembly along with the hydrant valve (valve being open and outlet closed) shall be pressure tested at a hydrostatic pressure of 21 kg/cm²g to detect any leakage through defects of casting.
- (ii) Flow test shall be conducted on the hydrant valves at a pressure of 7 kg/cm²g and the flow through the valve shall not be less than 900 litres/min.
- (iii) Leak tightness test of the valve seat shall be conducted at a hydrostatic test pressure of 14 kg/cm²g.

7.06.05 **Hoses, Nozzles, Branch Pipes and Hose Boxes**

Reinforced rubber-lined canvas hoses shall be tested hydrostatically. Following tests shall be included as per IS: 636. a) Hydrostatic proof pressure test at 21.4 kgf/cm²g b) Internal diameter The branch pipe, coupling and nozzles shall be subjected to a hydrostatic test pressure of 21 kg/cm²g for a period of 2¹/₂ minutes and shall not show any sign of leakage or sweating. Dimensional checks shall be made on the hose boxes and nozzle spanners.

8.00.00 **AIR VESSELS**

8.01.00 Air vessels shall be designed and fabricated of mild steel as class-II vessels as per IS: 2825 for a pressure of 14kg/cm² and shall be minimum 3 m³ capacity.

8.02.00 Inside surface of the tank shall be protected by anti-corrosive paints/coatings/linings as required.

8.03.00 Outside surfaces of the vessels shall be provided with one (1) coat of red lead primer with two (2) coats of synthetic enamel paint of approved colour and characteristics.

8.04.00 **Tests & Inspection**

8.04.01 Air vessels shall be hydraulically tested at 21kg/cm² for a period not less than one (1) hour.

8.04.02 All materials used for fabrication shall be of tested quality and test certificates shall be made available to the Owner.

8.04.03 Welding procedure and Welder's qualification tests will be carried out as per relevant IS Standard.

NDE tests, which will include 100% Radiography on longitudinal seams and spot radiography for circumferential seams, for pressure vessel will be carried out.

HEAT DETECTORS/FIRE DETECTORS AND SPRAY NOZZLES

9.00.01 Intent of Specification

This specification lays down the requirements of the smoke detectors, heat detectors and spray nozzles for use in various sub-systems of the fire protection system.

9.00.02 Codes and Standards

All equipment supplied shall conform to internationally accepted codes and standards. All equipment offered by Bidders should be TAC approved or have been in use in installations which have been approved by TAC.

9.01.00 Heat Detectors, Quartzoid bulb type. (Used in HVW spray system)

- a) Heat detectors shall be of any approved and tested type. Fusible chemical pellet type heat detectors are however not acceptable.
- b) Temperature rating of the heat detector shall be selected by the Bidder taking into consideration the environment in which the detectors shall operate. Minimum set point shall, however, be 79°C.
- c) Heat detectors shall be guaranteed to function properly without any maintenance work for a period of not less than twenty five (25) years.
- d) The heat detectors shall be mounted on a pipe network charged with water at suitable pressure. On receipt of heat from fire, the heat detector will release the water pressure from the network. This drop in water pressure will actuate the Deluge valve.

9.02.00 HVW Spray Nozzles (Projectors)

High velocity water spray system shall be designed and installed to discharge water in the form of a conical spray consisting of droplets of water travelling at high velocity which shall strike the burning surface with sufficient impact to ensure the formation of an emulsion. At the same time the spray shall efficiently cut off oxygen supply and provide sufficient cooling. Integral non-ferrous strainers shall be provided in the projectors ahead of the orifice to arrest higher size particles, which are not allowed to pass through the projectors.

9.03.00 Fire Detectors (Used in fire detection and alarm system)

9.03.01 Fire detectors shall be approved by FOC-London or similar international authorities.

9.03.02 Both smoke and heat type fire detectors shall be used. Bidder shall clearly indicate the mode of operation of detectors in his proposal.

9.03.03 The set point shall be selected after giving due consideration for ventilating air

velocity and cable insulation.

9.03.04 Fire detectors shall be equipped with an integral L.E.D. so that it shall be possible to know which of the detectors has been operated. The detectors, which are to be placed in the space above the false ceiling or in the floor void shall not have the response indicators on the body but shall be provided with remote response indicators.

9.03.05 Approval from Department of Atomic Energy (DAE), Government of India shall be made available for ionisation type smoke detectors. All accessories required to satisfy DAE shall also be included in the scope of supply.

Fire detectors shall be guaranteed to function properly without any maintenance work for a period of not less than ten (10) years.

PORTABLE AND WHEEL/ TROLLEY MOUNTED FIRE EXTINGUISHERS

10.00.01 This specification lays down the requirement regarding fire extinguishers of following types :

Portable fire extinguishers.

- a) Pressurised water type.
- b) Dry chemical powder type
- c) Carbon Dioxide type

Wheel/ Trolley mounted fire extinguishers. a) Mechanical foam type

10.00.02 All the extinguishers offered by the Bidder shall be of reputed make and shall be ISI marked.

10.01.00 Design and Construction

10.01.01 All the portable extinguishers shall be of freestanding type and shall be capable of discharging freely and completely in upright position.

10.01.02 Each extinguisher shall have the instructions for operating the extinguishers on its body itself.

10.01.03 All extinguishers shall be supplied with initial charge and accessories as required.

10.01.04 Portable type extinguishers shall be provided with suitable clamps for mounting on walls or columns.

10.01.05 All extinguishers shall be painted with durable enamel paint of fire red colour conforming to relevant Indian Standards.

10.02.00 Tests and Inspection

10.02.01 A performance demonstration test at site of five (5) percent or one (1) number whichever is higher, of the extinguishers shall be carried out by the Contractor. All consumable and replaceable items require for this test would be supplied by the Contractor without any extra cost to Employer.

10.02.02 Performance testing of extinguisher shall be in line of applicable Indian Standards. In case where no Indian Standard is applicable for a particular type of extinguisher, the method of testing shall be mutually discussed and agreed to before placement of order for the extinguishers.

10.03.00 **Painting**

Each fire extinguisher shall be painted with durable enamel paint of fire red colour conforming to relevant Indian Standards.

11.00.00 **INSTRUMENTS**

11.00.01 **Intent of Specification**

The requirements given in the sub-section shall be applicable to all the instruments being furnished under this specification.

11.00.02 All field mounted instruments shall be weather and dust tight, suitable for use under ambient conditions prevalent in the subject plant. All field mounted instruments shall be mounted in suitable locations where maximum accessibility for maintenance can be achieved.

11.01.00 **Local Instruments**

Pressure/ Differential Gauges & Switches.

11.01.01 The pressure sensing elements shall be continuous 'C' bourdon type.

11.01.02 The sensing elements for all gauges/switches shall be properly aged and factory tested to remove all residual stresses. They shall be able to withstand atleast twice the full scale pressure/vacuum without any damage or permanent deformation.

11.01.03 For all instruments, connection between the pressure sensing element and socket shall be braced or hard soldered.

11.01.04 Gauges shall be of 150 mm diameter dial with die-cast aluminium, enamel black finish case, aluminium screwed ring and clear plastic crystal cover glass. Upper range pointer limit stop for all gauges shall be provided.

11.01.05 All gauges shall be with stainless steel bourdon having rotary geared stainless steel movements.

11.01.06 Weatherproof type construction shall be provided for all gauges. This type of construction shall be fully dust tight, drip tight, weather resistant and splash proof with anti-corrosive painting conforming to NEMA-4.

11.01.07 All gauges shall have micrometer type zero adjuster.

11.01.08 Neoprene safety diaphragm shall be provided on the back of the instruments casing for pressure gauges of ranges 0-10 Kg/cm² and above.

11.01.09 Scales shall be concentric, white with black lettering and shall be in metric units.

11.01.10 Accuracy shall be \pm 1.0 percent of full range or better.

11.01.11 Scale range shall be selected so that normal process pressure is approximately 75 percent of full scale reading. For pressure gauges and pressure switches, the range shall not be less than 0 -16 Kg/cm²

11.01.12 All gauges shall have 1/2 inch NPT bottom connection.

11.01.13 All instruments shall conform to IS: 3624 - 1966.

11.01.14 All instruments shall be provided with 3 way gauge isolation valve or cock. Union nut, nipple and tail pipe shall be provided wherever required.

11.01.15 Switch element contact shall have two (2) NO and two (2) NC contacts rated for 240 Volts, 10 Amperes A.C. or 220 Volts, 5 Amperes D.C. Actuation set point shall be adjustable throughout the range. ON-OFF differential (difference between switch actuation and de-actuation pressures) shall be adjustable. Adjustable range shall be suitable for switch application.

11.01.16 Switches shall be sealed diaphragm, piston actuated type with snap action switch element. Diaphragm shall be of 316 SS.

11.01.18 Necessary accessories shall be furnished.

11.02.00 **Timers**

11.02.01 The timers shall be electro-mechanical type with adjustable delay onpick-up or reset as required.

11.02.02 Each timer shall have two pairs of contacts in required combination of NO and NC.

11.03.00 **Level Gauges/Indicator/Switches**

11.03.01 **Level Gauges**

- i. Gauge glasses shall be used for local level indication wherever shown in the flow diagram.
- ii. Gauge glasses, in general, shall be flag glass type with bolted cover. Body and cover material shall be of carbon steel with rubber lining
- iii. Level coverage shall be in accordance with operating requirements. Maximum length of a single gauge glass shall not exceed 1.4 M. Should a larger gauge glass be required, multiple gauges of preferably equal length shall be used with 50 mm overlap in visibility

- iv) Reflex type gauge glasses shall be used for colourless liquids and transparent type gauge glasses shall be used for all liquids having colour.
- v) Each gauge glass shall be complete with a pair of offset valves. Valves shall have union bonnet, female union level connection, flanged tank connection, and vent and drain plug.
- vi) Offset valves shall have corrosion resistant ball-check to prevent fluid loss in the event of gauge glass breakage. Valve body shall have a working pressure of 200 percent of the maximum static pressure at the maximum process fluid temperature. Valve body materials shall be of carbon steel with rubber lining.

11.03.02 Level Indicators

- i) Float type mechanical level gauges with linear scale type indicator shall be offered for measuring level of tanks wherever shown in the flow diagram.
- ii) AISI-316 stainless steel float, guide rope and tape shall be used. Housing shall be of mild steel painted with anti-corrosive painting.
- iii) The scale indicator shall be provided at a suitable height for ease of reading.
- iv) Accuracy shall be + 1% of scale range or better.

11.03.03 Level Switches

- i) Level switches shall be of ball float operated magnetic type complete with cage.
- ii) Materials of construction shall be suitable for process and ambient conditions. The float material shall be AISI-316 stainless steel.
- iii) Actuating switches shall be either hermetically sealed mercury type or snap acting micro-switches. Actuation set point shall be adjustable. ON-OFF differential (difference between switch actuation and de-actuation levels) shall be adjustable. Adjustable range shall be suitable for switch application. All switches shall be repeatable within + 1.0 percent of liquid level change required to activate switch. Contacts shall be rated for 50 watts resistive at 240 V A.C. Number of contacts shall be two NO and two NC for each level switch.

11.04.00 Solenoid Valves

11.04.01 The body of the valves shall be Forged brass or stainless steel.

11.04.02 The coil shall be continuous duty, epoxy moulded type Class-F, suitable for high temperature operation.

11.04.03 The enclosure shall be watertight, dust-tight and shall conform to NEMA-4 Standard.

11.04.04 The valves shall be suitable for mounting in any position.

11.05.00 Switches, Lamps, Meters Etc.

All electrical components on the panel namely push buttons, switches, lamps, meters etc. shall meet the requirements of sub-section Electrical enclosed with the specification.

11.06.00 All local instruments shall be inspected by Employer/Consultant as per the agreed quality plan.

Makes of control panel and local instruments, accessories shall be as per Employer's approval.

12.00.00 ELECTRIC MOTORS

12.01.00 General

12.01.01 This clause covers the requirements of three phase squirrel cage induction motors and single-phase induction motors.

12.01.02 The motors to be furnished, erected and commissioned as covered under this specification shall be engineered, designed, manufactured, erected, tested as per the requirements specified herein. These requirements shall however be read along with the requirements of the respective driven equipment being supplied under the specification of which this specification forms a part.

12.01.03 The motor supplied under this specification shall conform to the standards specified in GTR.

12.01.04 Terminal point for all motors supplied under this specification shall be at the respective terminal boxes.

12.01.05 Materials and components not specifically stated in this specification but are necessary for satisfactory operation of the motor shall be deemed to be included in the scope of supply of this specification.

12.01.06 Notwithstanding anything stated in this motor specification, the motor has to satisfy the requirement of the mechanical system during normal and abnormal conditions. For this the motor manufacturer has to coordinate with the mechanical equipment supplier and shall ensure that the motor being offered meets the requirements.

12.02.00 Codes & Standards

12.02.21 The design, manufacture, installation and performance of motors shall conform to the provisions of latest Indian Electricity Act and Indian Electricity Rules. Nothing in these specifications shall be construed to relieve the Contractor of his responsibility.

12.02.22 In case of contradiction between this specifications and IS or IEC, the stipulations

of this specification shall be treated as applicable.

12.02.23 National Electrical code for hazardous location and relevant NEMA standard shall also be applicable for motors located in hazardous location.

12.03.00 Design Features 12.03.01 Rating and type

- (i) The induction motors shall be of squirrel cage type unless specified otherwise.
- (ii) The motors shall be suitable for continuous duty in the specified ambient temperature.
- (iii) The MCR KW rating of the motors for 50oC ambient shall not be less than the power requirement imposed at the motor shaft by the driven equipment under the most onerous operation conditions as defined elsewhere, when the supply frequency is 51.5 Hz (and the motor is running at 103% of its rated speed).
- (iv) Motors shall be capable of giving rated output without reduction in the expected life span when operated continuously in the system having the following particulars:

a) Rated terminal voltage

From 0.2 to 200 KW 415V (3 Phase, solidly earthed)

Below 0.2 KW 240 V (1 Phase, solidly earthed)

Variation in voltage $\pm 6\%$.

b) Frequency 50 Hz $\pm 3\%$.

c) Any combination of (a) & (b)

12.03.02 Enclosure

Motors to be installed outdoor and semi-outdoor shall have hose proof enclosure equivalent to IP-55 as per IS: 4691. For motors to be installed indoor, the enclosure shall be dust proof equivalent to IP-54 as per IS: 4691.

12.03.03 Cooling method

Motors shall be TEFC (totally enclosed fan cooled) type.

12.03.04 Starting requirements

(i) **Induction motor**

- a) All induction motors shall be suitable for full voltage direct on-line starting. These shall be capable of starting and accelerating to the rated speed alongwith the driven equipment without exceeding the acceptable winding temperature even when the supply voltage drops down to 80% of the rated voltage.

- b) Motors shall be capable of withstanding the electro-dynamic stresses and heating imposed if it is started at a voltage of 110% of the rated value.
- c) The starting current of the motor at rated voltage shall not exceed six (6) times the rated full load current subject to tolerance as given in IS : 325.
- d) Motors when started with the driven equipment imposing full starting torque under the supply voltage condition specified under Clause 12.03.01 (iv) (a) shall be capable of withstanding at least two successive starts with coasting to rest between starts and motor initially at the rated load operating temperature. The motors shall also be suitable for three equally spread starts per hour, the motor initially at a temperature not exceeding the rated operating temperature.
- e) The locked rotor withstand time under hot condition at 110% of rated voltage shall be more than the starting time with the driven equipment at minimum permissible voltage (clause 12.03.04 (i) (a) by at least two seconds or 15% of the accelerating time whichever is greater. In case it is not possible to meet the above requirement the Bidder shall offer centrifugal type speed switch mounted on the motor shaft which shall remain closed for speeds lower than 20% and open for speeds above 20% of the rated speed. The speed switch shall be capable of withstanding 120% of the rated speed in either direction of rotation.

12.03.05 Running requirements

- (i) When the motors are operating at extreme condition of voltage and frequency given under clause no.12.03.01 (iv) the maximum permissible temperature rise over the ambient temperature of 50°C shall be within the limits specified in IS : 325 after adjustment due to increase ambient temperature specified herein.
- (ii) The double amplitude of motor vibration shall be within the limits specified in IS: 4729. Vibration shall also be within the limits specified by the relevant standard for the driven equipment when measured at the motor bearings.
- (iii) All the induction motors shall be capable of running at 80% of rated voltage for a period of 5 minutes with rated load commencing from hot condition.
- (iv) Induction motors shall be so designed as to be capable of withstanding the voltage and torque stresses developed due to the difference between the motor residual voltage and incoming supply voltage during fast changeover of buses. The necessary feature incorporated in the design to comply with this requirement shall be clearly indicated in the proposal.
- (v) Motors shall be capable of developing the rated full load torque even when the supply voltage drops to 70% of rated voltage. Such operation is envisaged for a period of one second. The pull out torque of the induction motors to meet this requirement shall not be less than 205% of full load torque.
- (vi) The motors shall be capable of withstanding for 10 seconds without stalling or abrupt change in speed (under gradual increase of torque) an excess torque of 60 percent of their rated torque, the voltage and frequency being maintained at their rated value.
- (vii) Guaranteed performance of the motors shall be met with tolerances specified in respective standards.

12.04.00 Construction Features

12.04.01 Stator

(i) Stator frame

The stator frames and all external parts of the motors shall be rigid fabricated steel or of casting. They shall be suitably annealed to eliminate any residual stresses introduced during the process of fabrication and machining.

(ii) Stator core

The stator laminations shall be made from suitable grade magnetic sheet steel varnished on both sides. They shall be pressed and clamped adequately to reduce the core and teeth vibration to minimum.

(iii) Insulation and winding

All insulated winding conductor shall be of copper. The overall motor winding insulation for all 415 volts motors shall be of epoxy thermosetting type i.e., class 'F' but limited to class-B operating from temperature rise consideration. Other motors may be of conventional class-B type. The windings shall be suitable for successful operation in hot, humid, tropical climate with the ambient temperature of 50°C.

12.04.02 Rotor

- (i) Rotors shall be so designed as to keep the combined critical speed with the driven equipment away from the running speed by atleast 20%.
- (ii) Rotors shall also be designed to withstand 120% of the rated speed for 2 minutes in either direction of rotation.

12.04.03 Terminal box leads

- (i) For motors of 415 Volts and below a single terminal box may be provided for power and accessories leads.
- (ii) Terminal boxes shall be of weatherproof construction designed for outdoor service. To eliminate entry of dust and water, gaskets of neoprene or approved equivalent shall be provided at cover joint and between box and motor frame.
- (iii) Terminal box shall be suitable for top and bottom entry of cables.
- (iv) Unless otherwise approved, the terminal box shall be capable of being turned through 360° in steps in 90°.
- (v) The terminals shall be complete with all accessories for connecting external cables. They shall be designed for the current carrying capacity and shall ensure ample phase to phase to ground clearances.
- (vi) Suitable tinned brass compression type cable glands and cable lugs shall be supplied by the Contractor to match Employer's cable.
- (vii) Terminal box for single core cable shall be of non- magnetic material.

(viii) Marking of all terminals shall be in accordance with IS: 4728.

12.04.04 Rating Plates

- (i) Rating plates shall be provided for all motors giving the details as called for in IS: 325 (for three phase squirrel cage induction motors).
- (ii) In addition to above, the rating plate shall indicate the following:
 - a) Temperature rise in °C under normal working conditions.
 - b) Phase sequence corresponding to the direction of rotation for the application.
 - c) Bearing identification number (in case of ball/ roller bearing) and recommended lubricants.

12.04.05 Other Constructional Features

- (i) Two independent earthing points shall be provided on opposite sides of the motor for bolted connection of Employer's earthing conductor to be specified to the successful Bidder.
- (ii) Motor weighing more than 25 kg. shall be provided with eyebolts, lugs or other means to facilitate lifting.

12.05.00 Paint and Finish

12.05.01 Motor external parts shall be finished and painted to produce a neat and durable surface, which would prevent rusting and corrosion. The equipment shall be thoroughly degreased, all sharp edges and scales removed and treated with one coat of primer and two coats of grey enamel paint.

12.05.02 Motor fans shall also be painted to withstand corrosion.

12.05.03 All fasteners used in the construction of the equipment shall be either of corrosion resistant material or heavy cadmium plated.

12.05.04 Current carrying fasteners shall be either of stainless steel or high tensile brass.

12.06.00 Tests at Manufacturers Works

12.06.01 Motors shall be subject to routine tests in accordance with IS: 325 & IS : 4029 standards.

12.06.02 In addition, the following tests shall also be carried out :

- a) 20% over speed test for 2 minutes on all rotors.
- b) Measurement of vibration.
- c) Measurement of noise level.
- d) Phase sequence and polarity checks relative to mechanical rotation.

12.06.03 Tests after installation at site

- (i) After installation and commissioning at site, the motors alongwith the driven equipment shall be subject to tests to ascertain their conformity with the requirement of this specification and those of the driven equipment specification

and the performance data quoted by the Bidder.

- (ii) In case of non-conformity of the motor with these specifications and performance requirement, the Engineer may at his discretion rejector ask for necessary rectification/replacement as detailed in general Terms and Conditions of Contract (GCC) Volume-I.

13.00.00 **BATTERY & BATTERY CHARGERS**

This clause covers the design, performance, manufacturing, construction features and testing of Battery and Battery charger used primarily for starting the diesel engine driving the fire water pumps. Battery Chargers shall be housed in Diesel Engine Panel.

13.01.00 **General Information**

13.01.01 The equipment specified hereinafter are required for starting the diesel engines and other operation of the plant as required.

13.01.02 For each diesel engine there shall be two (2) sets of Battery and two (2) sets of Battery Charger.

13.01.03 The D.C. voltage shall be obtained normally after necessary rectification by battery charger. The Battery Charging system shall be capable of meeting the following requirements :

13.01.04 Float charging the Battery.

13.01.05 Boost Charging the Battery.

13.01.06 The battery shall be large enough to crank the engine **3** times without charging in between and without getting drained to an extent which will affect its life.

13.01.07 The Bidder shall indicate the battery voltage and battery capacity in Ampere- Hour at ten (10) hour discharge rate. The battery voltage at any time during operation shall not be less than the minimum voltage required for operation of the D.C. loads.

13.02.00 **General Design** The Battery shall be located indoor

13.02.01 **Battery**

- (i) The cells shall be lead-acid type. The Battery shall be automotive type.
- (ii) The cells shall be sealed in type with anti-splash type vent plug.
- (iii) The cell terminal posts shall be provided with connector bolts and nuts, effectively coated with lead to prevent corrosion. Lead or lead coated copper connectors shall be furnished to connect up cells of battery set.
- (iv) Positive and Negative terminal posts shall be clearly and indelibly marked for easy identification.
- (v) The electrolyte shall be of battery grade Sulphuric Acid conforming to IS: 226-2962. Water for storage batteries conforming to IS: 1069 shall be used in the preparation of the electrolyte.

13.02.02 Battery Charger

- (i) The Bidder shall furnish the battery charging scheme complete with all necessary accessories such as transformers, switches, fuses, starters, contactors, diodes, ammeters, voltmeters and other devices as required for trouble free operation. All devices and equipment shall conform to relevant Indian Standard or shall be Superior to it.
- (ii) The scheme of the battery charger shall be such that the battery can be charged automatically as well as manually.
- (iii) The boost charger shall have sufficient capacity to restore a fully discharged Battery to a state of full charge in eight (8) hours with some spare margin over maximum charging rate. Suitable provision shall be kept so that, for a particular engine, any of the two (2) charger units can be used for charging any of the two (2) batteries.
- (iv) The instruments, switches and lamps shall be flush/semi-flush mounted on the front panel. Name plate of approved type shall be provided for each of these equipment.
- (v) The panel shall be complete with internal wiring and input-output terminal block. Terminal blocks shall be clip on type of suitable rating. All equipment and wire terminals shall be identified by symbols corresponding to applicable schematic/wiring diagram.
- (vi) Space heaters of adequate capacity shall be provided to prevent moisture condensation in the panel.

13.03.00 Testing

13.03.01 The Battery Charger shall also be subjected to the following tests at manufacturer's works as per IS - 4540

13.03.02 Insulation test.

13.03.03 Connection checking.

13.03.04 Measurement of voltage regulation.

13.03.05 Auxiliary of devices.

13.03.06 Alternating current measurement.

13.03.07 Performance test.

13.03.08 Temperature rise test.

13.03.09 Following acceptance tests shall be carried out in batteries as per IS:1651.

- a) Marking and packing
- b) Verification of dimensions
- c) Test for capacity
- d) Test for voltage during discharge

Battery and battery charger shall be checked for auto charging and providing sufficient power for three consecutive starting kicks to diesel engine within five minutes with A.C. supply switched off.

14.00.00 CONTROL & ANNUNCIATION PANELS

14.01.00 Intent of Specification

The following requirement shall be applicable to the control and annunciation panels furnished under these specifications.

14.02.00 General Information

14.02.01 The equipment specified herein are required for controlling, metering, monitoring and indication of electrical systems of the plant offered.

14.02.02 The selection and design of all the equipment shall be so as to ensure reliable and safe operation of the plant and shall be subjected to approval by the Employer.

14.02.03 The reference ambient temperature outside the panel shall be taken as 50°C and relative humidity 100%.

14.03.00 Equipment to be Furnished

Control & annunciation panels shall be furnished complete with all accessories and wiring for safe and trouble free operation of the plant. Details are included in sub-section General.

14.04.00 Constructional Details

14.04.01 The panel frames shall be fabricated using suitable mild steel structural sections or pressed and shaped cold-rolled sheet steel of thickness not less than 2.5 mm. Frames shall be enclosed in cold-rolled sheet steel of thickness not less than 1.6 mm. Stiffeners shall be provided wherever necessary.

14.04.02 Panels shall be of free standing type and shall be provided with hinged door with locking arrangement. The access doors, cutest and covers shall be equipped with neoprene/synthetic rubber gaskets (conforming to IS 11149-1984) all around and the latches sufficiently strong to hold them in alignment when closed. The panels to be installed outdoor or semi outdoor shall have a degree of protection of IP:55 and those installed indoor shall have a degree of protection of IP:52 as per IS:13947 Part-1.

14.04.03 If a panel consists of a number of panels, each panel should be mounted side by side and bolted together to form a compact unit, when two panels meet, the joints shall be smooth, close fittings and unobstructive.

14.04.04 Removable eye bolt or lifting lugs shall be provided on all panels to facilitate easy lifting.

14.04.05 The heights of all operating equipment on the panel shall be between 800 mm to 1600 mm from the finished floor level. The proper supporting arrangement shall

be provided by the Contractor.

14.04.06 Cable entries to the panel may be from bottom or top. The cable entry required will be intimated to the successful Bidder. A suitable removable gland plate of 3 mm thick shall be mounted not less than 200 mm above the floor level.

14.04.07 All equipment mounted on the front face of the panels shall be flush or semi-flush type. All equipment shall be so located that their terminal and adjustment are readily accessible for inspection or maintenance and their removal and replacement can be done without interruption of service to other equipment. The contractor shall submit the panel general arrangement drawings clearly bringing out internal mounting details, dimensions of equipment, clearance between the equipment and the edges of the panel, for approval.

14.05.00 Name Plates and Labels

14.05.01 Each panel shall be provided with prominent, engraved identification plates for all front mounted equipment. Panel identification name plate shall be provided at front and rear as required.

14.05.02 All name plates shall be of non-rusting metal or 3 ply lami cold, with white engraved lettering on black background. Inscription and lettering sizes shall be subjected to Employer's approval.

14.05.03 Suitable plastic sticker labels shall be provided for easy identification of all equipment located inside the panel. These labels shall be positioned so as to be clearly visible and shall give the device number, as mentioned in the wiring drawings.

14.06.00 AC/DC Power Supply

14.06.02 The Employer will provide one feeder each for AC and DC to the panel. The Contractor shall make for his own arrangements for providing these power supplies to different panels.

14.06.02 The Contractor shall provide suitable isolating switch fuse unit in the control panel for receiving the above incoming AC and DC supplies. Fuse and link shall be provided for isolating of individual circuit without disturbing other circuits.

14.07.00 Wiring

14.07.01 All inter panel wiring and connections between panels (if there is group of panels) including all bus wiring for AC & DC supplies shall be provided by the Contractor.

14.07.02 All internal wiring shall be carried out with 1100 V grade, single core, 1.5square mm or larger stranded copper wires having colour-coded PVC insulation. CT circuits shall be wired with 2.5 square mm copper wires, otherwise similar to the above.

14.07.03 Extra-flexible wire shall be used for wiring to devices mounted on moving parts such as doors.

14.07.04 Spare contacts of auxiliary relays, timers and switches shall be wired out to the terminal blocks as required by the Employer/Engineer at the detailed engineering.

14.08.00 **Terminal Blocks**

14.08.01 Terminal Blocks shall be of 650V grade, rated for 10 Amps and in one-piece moulding. It shall be complete with insulating barriers, clip-on type terminals, and identification strips. Marking on terminal strip shall correspond to the terminal numbering on wiring diagrams. It shall be similar to 'Elmex-Standard' type terminals.

14.08.02 Terminal blocks shall be arranged with at least 100 mm clearance between two sets of terminal block.

14.08.03 The terminal blocks shall have at least 20% spare terminals.

14.09.00 **Grounding**

A continuous copper bus 25 x 3 mm size shall be provided along the bottom of the panel structure. It shall run continuously throughout the length of the panel and shall have provision at both ends for connection to the station grounding grid (25 x 6 mm MS Flat).

14.10.00 **Space Heater and Lighting**

14.10.01 Space heaters shall be provided in the panels for preventing harmful moisture condensation.

14.10.02 The space heaters shall be suitable for continuous operation on 240VAC, 50 Hz, single phase supply and shall be automatically controlled by thermostat. Necessary isolating switches and fuses shall also be provided.

14.10.03 Free standing panel shall have a 240V AC, plug point and a fluorescent light operated by door switch.

14.11.00 **Control and Selector Switches**

14.11.01 Control and selector switches shall be of rotary type, with escutcheon plates clearly marked to show the function and positions.

14.11.02 Control/selector switches shall be spring return or stay put type as per the requirements. Handles of control/selector switches shall be black in colour. Shape and type of handles shall be to the approval of the Employer.

14.11.03 The contact ratings shall be at least the following:

- i) Make and carry continuously 10 Amp.
- ii) Breaking current at 240V DC 1Amp. (Inductive)
- iii) Breaking current at 240V DC 5 Amp. at 0.3 p.f. lagging

14.12.00 **Push Buttons**

14.12.01 Push buttons shall be spring return, push to actuate type and rated to continuously carry and break 10A at 240V AC and 0.5A (Inductive) at 220V DC. The push buttons shall have at least 1 NO and 1 NC contact. All contact faces shall be of silver or silver alloy.

14.12.02 All push buttons shall be provided with integral escutcheon plates marked with its function.

14.12.03 The colour of buttons shall be as follows :

Green For motor START, Breaker CLOSE, Valve/ damper OPEN.

Red For motor TRIP, Breaker OPEN, Valve/ damper CLOSE.

Black For all annunciation functions, overload reset and miscellaneous.

14.12.04 Red push buttons shall always be located to the left of green push buttons. In case of clinker grinder etc. the push buttons would be black-red-green from left to right.

14.13.00 Indicating Lamps

14.13.01 Indicating lamps shall be of the panel mounting, filament type and of low-watt consumption. Lamps shall be provided with series resistors preferably built-in- the lamps assembly. The lamps shall have escutcheon plates marked with its function, wherever necessary.

14.13.02 Lamp shall have translucent lamp covers of the following colours: Red for motor

OFF, Valve/damper OPEN, Breaker CLOSED. Green for motor ON,

Valve/damper CLOSED, Breaker OPEN. White for motor AUTO-TRIP. Blue for all

healthy conditions (e.g. control supply, lub oil pressure and also for spring

charged). Amber for all ALARM conditions (e.g. pressure low, over load and also

for 'service' and 'Test' position indication).

14.13.03 Bulbs and lamps covers shall be easily replaceable from the front of the panel.

14.13.04 Indicating lamps should be located directly above the associated pushbutton/control switches. Red lamps shall variably be located to the right of the green lamp. In case a white lamp is also provided, it shall be placed between the red and green lamps. Blue and amber lamps should normally be located above the red and green lamps.

14.14.00 Fuses

14.14.01 All fuses shall be of HRC cartridge plug-in-type and shall be of suitable rating, depending upon circuit requirements.

14.14.02 All fuses shall be mounted on fuse carriers, which shall be mounted on fuse-bases.

14.15.00 Contactors

14.15.01 Contactors shall be of air break, electromagnetic type rated as per requirement. These shall be of utilization category AC 3 as per IS: 2959.

14.15.02 Operating coils of AC contactors shall be of 240V AC or 220V DC as required. AC contactors shall operate satisfactorily between 85% to 110% of the rated voltage. The Contactor shall not drop out at 70% of the rated voltage.

14.15.03 DC contactors shall have a coil voltage of 220V DC and shall be suitable for satisfactory continuous operation at 80% to 110% of the rated voltage.

14.16.00 Relays and Timers

14.16.01 All auxiliary relays & timers shall be of proven design and of reputed make. Contacts of relays and timers shall be of solid silver or silver cadmium oxide or solid silver faced. Timers shall have the provision to adjust the delay on pick-up or reset as required.

14.16.02 All relays and timers shall have at least two NO and two NC contacts.

14.16.03 All relays and timers shall be suitable for 240V AC and 220V DC as required. DC relays shall operate satisfactorily between 70% to 110% and AC relays shall be suitable for voltage variation between 80% to 110%.

14.17.00 Indication Instruments

14.17.01 All indicating and integrating meters shall be flush mounted on panel front. The instruments shall be of at least 96 mm square size with 90 degree scales and shall have an accuracy class of 2.0 or better. The covers and cases of instruments and meters shall provide a dust and vermin proof construction.

14.17.02 All instruments shall be compensated for temperature errors and factory calibrated to directly read the primary quantities. Means shall be provided for zero adjustment removing or dismantling the instruments.

14.17.03 All instruments shall have white dials with black numerals and lettering. Black knife edge pointer with parallax free dials will be preferred.

14.17.04 Ammeters provided on motor feeders shall have a compressed scale at the upper current region to cover the starting current.

14.18.00 Annunciation System

14.18.01 The annunciation system shall be complete with all necessary relays, flashers and other accessories required for the proper operation of the equipment and shall be completely solid state. The control circuit shall be mounted on plug-in type glass epoxy printed circuit boards. Audible alarms for the system shall be mounted inside the panel. One set of acknowledge, test and reset push buttons shall be mounted on the panel.

- 14.18.02 Indications shall be engraved on Acrylic inscription plate window and shall be visible clearly when the indication lamp is lighted (black letter on white background). Each window shall be provided with two lamps.
- 14.18.03 Audible hooter shall sound when a trouble contact operates and shall continue to sound until the acknowledge button is pressed. In addition to the hooters provided on annunciation panels, a hooter shall be provided outside FFPH which shall sound in any fire alarm condition.
- 14.18.04 Indication lamps shall flash when trouble contact operates and shall continue flashing until acknowledge button is pressed.
- 14.18.05 After acknowledge button is pressed, the hooter and flashing shall stop but the indication lamp shall remain lighted.
- 14.18.06 After trouble is cleared indication lamps shall be ready and shall go off only when reset.
- 14.18.07 Silencing the hooter in conjunction with one trouble contact shall not stop and hooter sounding if another trouble contact operates.
- 14.18.08 When test button is pressed, all lamps shall flash and hooter shall sound.
- 14.18.09 Annunciator systems shall operate on 220V DC Systems.
- 14.18.10 The annunciation system shall include alarm for AC control system failure (working on DC supply), DC supply failure (working on AC supply) and test facilities for these alarms.
- 14.18.11 List of annunciations required on the panels has been listed elsewhere. The Contractor shall also provide additional annunciations if desired by the Employer/Engineer during Vendor drawing review stage and for such additional annunciations no extra charges shall be claimed by the Contractor, if the number of such additions are within 10% of the number stipulated in this specification.
- 14.18.12 20% spare windows shall be provided on the panel.

14.19.00 Painting

- 14.19.01 All sheet steel work shall be pre-treated, in tanks, in accordance with IS:6005, Degreasing shall be done by alkaline cleaning. Dust and scale shall be removed by pickling, the parts shall be washed in running water. Then these shall be rinsed in slightly alkaline hot water and dried. The phosphate coating shall be "Class-C" as specified in IS: 6005. The phosphated surfaces shall be rinsed and passivated prior to application of stoved lead oxide primer coating. After primer application, two coats of finishing synthetic enamel paint on panels shall be applied. Electrostatic painting shall also be acceptable. Finishing paint on panels shall be shade 692 (smoke grey) of IS:5 unless required otherwise by the Employer. The inside of the panels shall be glossy white. Each coat of finishing shall be properly stoved. The paint thickness shall not be less than 50 microns. Finished parts shall be coated by peelable compound by spraying method to protect the finished surface from scratches, grease, dirt and oily spots during testing, transportation

handling and erection.

14.20.00 Tests

14.20.01 Following tests/inspection shall be carried out by the Contractor in the presence of Employer's representative:

(A) Factory Tests

- 1 Compliance with approved drawings, data and specification.
- 2 Visual check for workmanship.
- 3 Wiring continuity and functional checks.
- 4 Calibration of instruments, relays and metres wherever required by inspector.
- 5 HV test
- 6 Insulation resistance measurement before and after HV test.

(B) Inspection/Testing at site:

- 1 IR test before and after HV test
- 2 HV Test
- 3 Functional Testing.

(C)

- 1 The Fire detection and annunciation panel shall be subjected to functional tests.
- 2 The Annunciation System shall be routine tested

SECTION - 3

PROJECT DETAILS GENERAL TECHNICAL REQUIREMENTS

1.1 PROJECT DETAILS

SITE INFORMATION

	Particular	Details
a)	Customer	Bihar State Electricity Board
b)	Project Title	220/ 132kV Pusauli Substation & Dehri Extn.
c)	Location	BIHAR (PUSAULI)
d)	Transport Facilities	ROAD/ TRAIN Nearest Airport Varanasi

1.0 GENERAL

This Chapter covers Technical Requirements and requirements of auxiliary items.

- a) Equipment furnished shall be complete in every respect with all mountings, fittings, fixtures and standard accessories normally provided with such equipment and/or needed for erection, completion and safe operation of the equipment as required by applicable codes unless included in the list of exclusions.
- b) Material and components not specifically stated in this specification but which are necessary for satisfactory operation of the equipment and accessories specified in this specification shall be deemed to be included unless specifically excluded and shall be supplied at no extra cost.
- c) Whenever a material or article is specified or described by the name of a particular brand, manufacturer or vendor, the specific name mentioned shall be understood as establishing type, function and quality and not as limiting competition.
- f) The Bidder shall clearly indicate in the bid, the specific standards in accordance with which the works will be carried out.
- g) The equipment must be new, of highest grade, the best quality of their kind, to best engineering practice and latest state of art, and in accordance with purpose for which they are intended and ensure satisfactory performance throughout the service life.
- h) All similar parts of the equipment shall be made to gauge and shall be interchangeable with and shall be made of same materials and workmanship as the corresponding parts of the equipment. Where feasible, common components, units shall be employed in different pieces of equipment in order to optimize the spare part stock-up and utilization.

2.0 SERVICES TO BE PERFORMED BY THE EQUIPMENT BEING FURNISHED

- a) The equipment furnished under this specification shall perform all its functions and operate satisfactorily without showing undue strain, restrike etc.
- b) The equipment shall be able to withstand forces due to wind load, short circuit, system over voltages, fluctuations, frequency variations etc., all forces considered together or the short circuit of the equipment.

3.0 STANDARDS

- a) The equipment to be furnished under this specification shall conform to latest issue with all amendments of standard specified under respective Chapters of this Specification. The Bidder shall note that standards mentioned in the specification are not. The Contractor shall also note that list of standards presented in this specification is not complete. Whenever necessary the list of standards shall be considered in conjunction with specific IS/IEC. When the specific requirements stipulated in the specifications exceed or differ than those required by the applicable standards, the stipulation of the specification shall take precedence.
- b) Other internationally accepted standards which ensure equivalent or better performance than that specified in the standards referred shall also be accepted.
- c) In case governing standards for the equipment is different from IS or IEC, the salient points of difference shall be clearly brought out in additional information schedule alongwith English language version of standard or relevant extract of the same. The equipment conforming to standards other than IS/IEC shall be subject to Employer's approval.

4.0 ENGINEERING DATA AND DRAWINGS

- 4.1 The list of drawings/documents which are to be submitted to the Purchaser shall be discussed and finalised by the Purchaser at the time of award.

The Contractor shall necessarily submit all the drawings/ documents unless anything is waived.

- 4.2 The Contractor shall submit 4 (four) sets of drawings/ design documents /data / detailed bill of quantity and 1 (one) set of test reports for the approval of the Purchaser. The contractor shall also submit the softcopy of the above documents in addition to hardcopy.

4.3 Drawings

- 4.3.1 All drawings submitted by the Contractor shall be in sufficient detail to indicate the type, size, arrangement, material description, Bill of Materials, weight of each component, break-up for packing and shipment, dimensions, internal & the external connections, fixing arrangement required and any other information specifically requested in the specifications.

- 5.3.2 Drawings submitted by the Contractor shall be clearly marked with the name of the Purchaser, the unit designation, the specifications title, the specification number and the name of the Project. BSEB has standardized a large number of drawings/documents of various make including type test reports which can be used for all projects having similar requirements and in such cases no

project specific approval (except for list of applicable drawings alongwith type test reports)

is required. However, distribution copies of standard drawings/documents shall be submitted as per provision of the contract. All titles, noting, markings and writings on the drawing shall be in English. All the dimensions should be in SI units.

5.3.3 The review of these data by the Purchaser will cover only general conformance of the data to the specifications and documents, interfaces with the equipment provided under the specifications, external connections and of the dimensions which might affect substation layout. This review by the Purchaser may not indicate a thorough review of all dimensions, quantities and details of the equipment, materials, any devices or items indicated or the accuracy of the information submitted. This review and/or approval by the Purchaser shall not be considered by the Contractor, as limiting any of his responsibilities and liabilities for mistakes and deviations from the requirements, specified under these specifications and documents.

5.5 All manufacturing and fabrication work in connection with the equipment prior to the approval of the drawings shall be at the Contractor's risk. The Contractor may make any changes in the design which are necessary to make the equipment conform to the provisions and intent of the Contract and such changes will again be subject to approval by the Purchaser. Approval of Contractor's drawing or work by the Purchaser shall not relieve the contractor of any of his responsibilities and liabilities under the Contract.

5.6 All engineering data submitted by the Contractor after final process including review and approval by the Purchaser shall form part of the Contract Document and the entire works performed under these specifications shall be performed in strict conformity, unless otherwise expressly requested by the Purchaser in Writing.

5.7 **Approval Procedure**

The scheduled dates for the submission of the drawings as well as for, any data/information to be furnished by the Purchaser would be discussed and finalised at the time of award. The following schedule shall be followed generally for approval and for providing final documentation.

- | | | |
|------|---|---|
| i) | Approval/comments/
Purchaser on initial
submission | As per agreed by
schedule |
| ii) | Resubmission
(Whenever
required) | Within 3 (three) weeks
from date of comments |
| iii) | Approval or comments | Within 3 (three) weeks of
receipt of resubmission. |
| iv) | Furnishing of distribution
Copies (5 hard copies per
substation and one scanned
Copy (pdf format) for Corporate
Centre) | 2 weeks from the date
of approval |
| v) | Furnishing of distribution copies of test reports | |

- (a) Type test reports 2 weeks from the date
(one scanned softcopy in of final approval pdf format per substation plus one for corporate centre & one hardcopy per substation)
- (b) Routine Test Reports -do-
(one copy for each substation)
- vi) Furnishing of instruction/
operation manuals (2 copies
per substation and one softcopy
(pdf format) for corporate centre
& per substation) As per agreed schedule
- (vii) As built drawings (two sets of
hardcopy per substation & one
softcopy (pdf format) for
corporate centre& per substation) On completion of entire works

NOTE :

- (1) The contractor may please note that all resubmissions must incorporate all comments given in the earlier submission by the Purchaser or adequate justification for not incorporating the same must be submitted failing which the submission of documents is likely to be returned.
- (2) All drawings should be submitted in softcopy form, however substation design drawings like SLD, GA, all layouts etc. shall also be submitted in AutoCAD Version. SLD, GA & layout drawings shall be submitted for the entire substation in case of substation extension also.
- (3) The instruction Manuals shall contain full details of drawings of all equipment being supplied under this contract, their exploded diagrams with complete instructions for storage, handling, erection, commissioning, testing, operation, trouble shooting, servicing and overhauling procedures.
- (4) If after the commissioning and initial operation of the substation, the instruction manuals require any modifications/ additions/changes, the same shall be incorporated and the updated final instruction manuals shall be submitted by the Contractor to the Purchaser.
- (5) The manufacturer shall furnish to the Purchaser catalogues of spare parts.
- (6) All As-built drawings/documents shall be certified by site indicating the changes before final submission.

6.0 MATERIAL WORKMANSHIP

6.1 General Requirement

- 6.1.1 Where the specification does not contain references to workmanship, equipment, materials and components of the covered equipment, it is essential that the same must be new, of highest grade of the best quality of their kind, conforming to best engineering practice and suitable for the purpose for which they are intended.
- 6.1.2 All materials and equipment shall be installed in strict accordance with the manufacturer's recommendation(s). Only first-class work in accordance with the best modern practices will be accepted. Installation shall be considered as being the erection of equipment at its permanent location. This, unless otherwise

specified, shall include unpacking, cleaning and lifting into position, grouting, levelling, aligning, coupling of or bolting down to previously installed equipment bases/foundations, performing the alignment check and final adjustment prior to initial operation, testing and commissioning in accordance with the manufacturer's tolerances, instructions and the Specification. All factory assembled rotating machinery shall be checked for alignment and adjustments made as necessary to re-establish the manufacturer's limits suitable guards shall be provided for the protection of personnel on all exposed rotating and / or moving machine parts and shall be designed for easy installation and removal for maintenance purposes. The spare equipment(s) shall be installed at designated locations and tested for healthiness.

6.2 Provisions For Exposure to Hot and Humid climate

6.2.1 Degree of Protection

The enclosures of the Control Cabinets, Junction boxes and Marshalling Boxes, panels etc. to be installed shall provide degree of protection as detailed here under:

- a) Installed out door: IP- 55
- b) Installed indoor in air conditioned area: IP-31
- c) Installed in covered area: IP-52
- d) Installed indoor in non air conditioned area where possibility of entry of water is limited: IP-41.
- e) For LT Switchgear (AC & DC distribution Boards) : IP-52

The degree of protection shall be in accordance with IS: 13947 (Part-I) / IEC-60947 (Part-I) / IS 12063 / IEC-60529. Type test report for degree of protection test, shall be submitted for approval.

7.0 QUALITY ASSURANCE PROGRAMME

7.1 To ensure that the equipment and services under the scope of this Contract whether manufactured or performed within the supplier's Works or at his Sub- contractor's premises or at the Purchaser's site or at any other place of Work are in accordance with the specifications, the supplier shall adopt suitable quality assurance programme to control such activities at all points necessary. The detailed programme shall be submitted by the contractor after the award for reference. A quality assurance programme of the supplier shall generally cover the following:

- (a) His organisation structure for the management and implementation of the proposed quality assurance programme:
- (b) Documentation control system;
- (c) Qualification data for bidder's key personnel;
- (d) The procedure for purchases of materials, parts components and selection of sub-Contractor's services including vendor analysis, source inspection, incoming raw material inspection, verification of material purchases etc.
- (e) System for shop manufacturing and site erection controls including process controls and fabrication and assembly control;
- (f) Control of non-conforming items and system for corrective actions;

- (g) Inspection and test procedure both for manufacture and field activities.
- (h) Control of calibration and testing of measuring instruments and field activities;
- (i) System for indication and appraisal of inspection status;
- (j) System for quality audits;
- (k) System for authorising release of manufactured product to the Purchaser.
- (l) System for maintenance of records;
- (m) System for handling storage and delivery; and
- (n) A quality plan detailing out the specific quality control measures and procedures adopted for controlling the quality characteristics relevant to each item of equipment furnished and/or services rendered.

BSEB/ BHEL or his duly authorized representative reserves the right to carry out quality audit and quality surveillance of the system and procedure of the supplier/his vendor's quality management and control activities.

7.2 Quality Assurance Documents

The supplier would be required to submit all the Quality Assurance Documents as stipulated in the Quality Plan at the time of BSEB/ BHEL inspection of equipment/material

8.0 TYPE TESTING, INSPECTION, TESTING & INSPECTION CERTIFICATE

8.1 All equipment being supplied shall conform to type tests as per technical specification and shall be subject to routine tests in accordance with requirements stipulated under respective sections.

8.2 The reports for all type tests as per technical specification shall be furnished by the supplier alongwith equipment / material drawings. However, type test reports of similar equipments/ material already accepted in BSEB shall be applicable for all project with similar requirement. The type tests conducted earlier should have either been conducted in accredited laboratory (accredited based on ISO / IEC Guide 25 / 17025 or EN 45001 by the national accreditation body of the country where laboratory is located) or witnessed by BSEB or representative authorized by BSEB or Utility or representative of accredited test lab or reputed consultant.

The test reports submitted shall be of the tests conducted within last 5 (five) years. In case the test reports are of the test conducted earlier than 5 (five) years prior to the date of bid opening, the contractor shall repeat these test(s) at no extra cost to BHEL.

Further, in the event of any discrepancy in the test reports i.e. any test report not acceptable due to any design/manufacturing changes (including substitution of components) or due to non-compliance with the requirement stipulated in the Technical Specification or any/all type tests not carried out, same shall be carried out without any additional cost implication to the Purchaser.

The Contractor shall intimate the Purchaser the detailed program about the tests atleast two (2) weeks in advance in case of domestic supplies & six (6) weeks in advance in case of foreign supplies.

Further, in case type tests are required to be conducted/repeated and

- the deputation of Inspector/Purchaser's representative is required, then all the expenses shall be borne by the contractor.
- 8.3 The Purchaser reserves the right to witness any or all the type tests. The Purchaser also reserves the right to waive the repeating of type tests partly or fully and in case of waiver, test charges for the same shall not be payable.
- The Purchaser shall bear all expenses for deputation of purchaser's representative(s) for witnessing the type tests under this clause except in the case of re-deputation if any, necessitated due to no fault of the purchaser.
- For outdoor receptacles, trefoil clamps, diesel engine, alternator, motors, cable glands and junction boxes, type test reports are not required to be submitted for the makes indicated BSEB approved list of subvendors. For the new makes (other than those indicated at BSEB approved list of subvendors), type test reports as per relevant standard shall be submitted for purchaser's approval.
- 8.4 The Purchaser, his duly authorised representative and/or outside inspection agency acting on behalf of the Purchaser shall have at all reasonable times free access to the Contractor's/sub-vendors premises or Works and shall have the power at all reasonable times to inspect and examine the materials and workmanship of the Works during its manufacture or erection if part of the Works is being manufactured or assembled at other premises or works, the Contractor shall obtain for the Engineer and for his duly authorised representative permission to inspect as if the works were manufactured or assembled on the Contractor's own premises or works. Inspection may be made at any stage of manufacture, despatch or at site at the option of the Purchaser and the equipment if found unsatisfactory due to bad workmanship or quality, material is liable to be rejected.
- 8.5 The Contractor shall give the Purchaser /Inspector fifteen (15) days written notice for on-shore and six (6) weeks notice for off-shore material being ready for joint testing including contractor and BSEB. Such tests shall be to the Contractor's account except for the expenses of the Inspector. The Purchaser /inspector, unless witnessing of the tests is virtually waived, will attend such tests within fifteen (15) days of the date of which the equipment is notified as being ready for test/inspection, failing which the Contractor may proceed alone with the test which shall be deemed to have been made in the Inspector's presence and he shall forthwith forward to the Inspector duly certified copies of tests in triplicate.
- 8.6 The Purchaser or Inspector shall, within fifteen (15) days from the date of inspection as defined herein give notice in writing to the Contractor, of any objection to any drawings and all or any equipment and workmanship which in his opinion is not in accordance with the Contract. The Contractor shall give due consideration to such objections and shall either make the modifications that may be necessary to meet the said objections or shall confirm in writing to the Purchaser /Inspector giving reasons therein, that no modifications are necessary to comply with the Contract.
- 8.7 When the factory tests have been completed at the Contractor's or Sub- Contractor's works, the Purchaser/inspector shall issue a certificate to this effect within fifteen (15) days after completion of tests but if the tests are not witnessed by the Purchaser /Inspector, the certificate shall be issued within fifteen (15) days of receipt of the Contractor's Test certificate by the Engineer/Inspector. Failure of the Purchaser /Inspector to issue such a certificate

shall not prevent the Contractor from proceeding with the Works. The completion of these tests or the issue of the certificate shall not bind the Purchaser to accept the equipment should, it, on further tests after erection, be found not to comply with the Contract. The equipment shall be dispatched to site only after approval of test reports and issuance of CIP by the Purchaser.

- 8.8 In all cases where the Contract provides for tests whether at the premises or at the works of the Contractor or of any Sub-Contractor, the Contractor except where otherwise specified shall provide free of charge such items as labour, materials, electricity, fuel, water, stores, apparatus and instruments as may be reasonably demanded by the Purchaser /Inspector or his authorised representative to carry out effectively such tests of the equipment in accordance with the Contract and shall give facilities to the Purchaser /Inspector or to his authorised representative to accomplish testing.
- 8.9 The inspection by Purchaser and issue of Inspection Certificate thereon shall in no way limit the liabilities and responsibilities of the Contractor in respect of the agreed quality assurance programme forming a part of the Contract.
- 8.10 The Purchaser will have the right of having at his own expenses any other test(s) of reasonable nature carried out at Contractor's premises or at site or in any other place in addition of aforesaid type and routine tests, to satisfy that the material comply with the specification.
- 8.11 The Purchaser reserves the right for getting any field tests not specified in respective sections of the technical specification conducted on the completely assembled equipment at site. The testing equipments for these tests shall be provided by the Purchaser.

9.0 TESTS

9.1 Pre-commissioning Tests

On completion of erection of the equipment and before charging, each item of the equipment shall be thoroughly cleaned and then inspected jointly by the Purchaser and the Contractor for correctness and completeness of installation and acceptability for charging, leading to initial pre-commissioning tests at Site. The list of pre-commissioning tests to be performed is given in respective chapters and shall be included in the Contractor's quality assurance programme.

9.2 Commissioning Tests

- 9.2.1 The available instrumentation and control equipment will to be used during such tests and the Purchaser will calibrate, all such measuring equipment and devices as far as practicable.
- 9.2.2 Any special equipment, tools and tackles required for the successful completion of the Commissioning Tests shall be provided by the Contractor, free of cost.
- 9.2.3 The specific tests requirement on equipment have been brought out in the respective chapters of the technical specification.

10.0 PACKAGING & PROTECTION

- 10.1 All the equipments shall be suitably protected, coated, covered or boxed and crated to prevent damage or deterioration during transit, handling and storage at Site till the time of erection. On request of the Purchaser, the Contractor shall also submit packing details/associated drawing for any

equipment/material under his scope of supply, to facilitate the Purchaser to repack any equipment/material at a later date, in case the need arises. While packing all the materials, the limitation from the point of view of availability of Railway wagon sizes in India should be taken into account. The Contractor shall be responsible for any loss or damage during transportation, handling and storage due to improper packing. Any demurrage, wharfage and other such charges claimed by the transporters, railways etc. shall be to the account of the Contractor. Purchaser takes no responsibility of the availability of the wagons.

- 10.2 All coated surfaces shall be protected against abrasion, impact, discolouration and any other damages. All exposed threaded portions shall be suitably protected with either a metallic or a non-metallic protecting device. All end of all valves and pipings and conduit equipment connections shall be properly sealed with suitable devices to protect them from damage.

11.0 PAINTING

- 11.2 Two coats of the primer, two coats of finishing synthetic enamel paint shall be applied, each coat followed by stoving. The second finishing coat shall be applied after inspection of first coat of painting.

- 11.3 The exterior and interior colour of the paint in case of new substations shall preferably be RAL 7032 for all equipment, marshalling boxes, junction boxes, control cabinets, panels etc. unless specifically mentioned under respective sections of the equipments. Glossy white colour inside the equipments /boards/panels/junction boxes is also acceptable. The exterior colour for panels shall be matching with the existing panels in case of extension of a substation. Each coat of primer and finishing paint shall be of slightly different shade to enable inspection of the painting. A small quantity of finishing paint shall be supplied for minor touching up required at site after installation of the equipments.

- 11.4 In case the Bidder proposes to follow his own standard surface finish and protection procedures or any other established painting procedures, like electrostatic painting etc., the procedure shall be submitted alongwith the Bids for Purchaser's review & approval.

12.0 HANDLING, STORING AND INSTALLATION

- 12.1 In accordance with the specific installation instructions as shown on manufacturer's drawings or as directed by the Purchaser or his representative, the Contractor shall unload, store, erect, install, wire, test and place into commercial use all the equipment included in the contract. Equipment shall be installed in a neat, workmanlike manner so that it is level, plumb, square and properly aligned and oriented. Commercial use of switchyard equipment means completion of all site tests specified and energisation at rated voltage.

- 12.2 Contractor may engage manufacturer's Engineers to supervise the unloading, transportation to site, storing, testing and commissioning of the various equipment being procured by them separately. Contractor shall unload, transport, store, erect, test and commission the equipment as per instructions of the manufacturer's supervisory Engineer(s) and shall extend full cooperation to them.

- 12.3 The contractor shall have to ensure that the hard and flat indoor and outdoor storage areas are in place prior to commencement of delivery of

material at site. Contractor shall also ensure availability of proper unloading and material handling equipment like cranes etc. and polyester/nylon ropes of suitable capacity to avoid damage during unloading and handling of material at site. All indoor equipments shall be stored indoors. Outdoor equipment may be stored outdoors but on a hard and flat raised area properly covered with waterproof and dustproof covers to protect them from water seepage and moisture ingress. However, all associated control panels, marshalling boxes operating boxes etc. of outdoor equipments are to be stored indoors only.

Storage of equipment on top of another one is not permitted if the wooden packing is used. Material opened for joint inspection shall be repacked properly as per manufacturer's recommendations.

During storage of material regular periodic monitoring of important parameters like oil level / leakage, SF6 / Nitrogen pressure etc. shall be ensured by the contractor.

- 12.4 In case of any doubt/misunderstanding as to the correct interpretation of manufacturer's drawings or instructions, necessary clarifications shall be obtained from the Purchaser. Contractor shall be held responsible for any damage to the equipment consequent to not following manufacturer's drawings/instructions correctly.
- 12.5 Where assemblies are supplied in more than one section, Contractor shall make all necessary mechanical and electrical connections between sections including the connection between buses. Contractor shall also do necessary adjustments/alignments necessary for proper operation of circuit breakers, isolators and their operating mechanisms. All components shall be protected against damage during unloading, transportation, storage, installation, testing and commissioning. Any equipment damaged due to negligence or carelessness or otherwise shall be replaced by the Contractor at his own expense.
- 12.6 Contractor shall be responsible for examining all the shipment and notify the Purchaser immediately of any damage, shortage, discrepancy etc. for the purpose of Purchaser's information only. The Contractor shall submit to the Purchaser every week a report detailing all the receipts during the weeks. However, the Contractor shall be solely responsible for any shortages or damages in transit, handling and/or in storage and erection of the equipment at Site. Any demurrage, wharfage and other such charges claimed by the transporters, railways etc. shall be to the account of the Contractor.
- 12.7 The Contractor shall be fully responsible for the equipment/material until the same is handed over to the Purchaser in an operating condition after commissioning. Contractor shall be responsible for the maintenance of the equipment/material while in storage as well as after erection until taken over by Purchaser, as well as protection of the same against theft, element of nature, corrosion, damages etc.
- 12.8 Where material / equipment is unloaded by Purchaser before the Contractor arrives at site or even when he is at site, Purchaser by right can hand over the same to Contractor and there upon it will be the responsibility of Contractor to store the material in an orderly and proper manner.
- 12.9 The Contractor shall be responsible for making suitable indoor storage facilities, to store all equipment which requires indoor storage.
- 12.10 The words 'erection' and 'installation' used in the specification are synonymous.

12.11 Exposed live parts shall be placed high enough above ground to meet the requirements of electrical and other statutory safety codes.

12.12 The design and workmanship shall be in accordance with the best engineering practices to ensure satisfactory performance throughout the service life. If at any stage during the execution of the Contract, it is observed that the erected equipment(s) do not meet the above minimum clearances as given in clause 4.7.1 the Contractor shall immediately proceed to correct the discrepancy at his risks and cost.

12.13 Equipment Bases

A cast iron or welded steel base plate shall be provided for all rotating equipment which is to be installed on a concrete base unless otherwise agreed to by the Purchaser. Each base plate shall support the unit and its drive assembly, shall be of a neat design with pads for anchoring the units, shall have a raised lip all around, and shall have threaded drain connections.

SECTION 4 GUARANTEED AND TECHNICAL PARTICULARS

1.0 LIST OF TECHNICAL DATASHEETS

In this section Technical Datasheets (TDS) of various equipment/items and system drawings that are required to be generated is furnished herewith. List of datasheets/drawings to be submitted given below.

The list furnished here is tentative and additional documents may be required during detailed engineering.

Sl.	List of Data sheets of FPS items
01.	Datasheet of Pumps
02.	Datasheet of Diesel Engine
03.	Datasheet of Motor for Pumps
04.	Datasheet of Motor for Jockey Pump
05.	Datasheet of Deluge Valve
06.	Datasheet of HVWS Nozzle
07.	Datasheet of QBD
08.	Datasheet of Hydrant Valve
09.	Datasheet of MS Hose Box
10.	Datasheet of Hose, Coupling and Branch Pipe with Nozzle
11.	Datasheet for Portable Fire Extinguishers
13.	Data Sheet of CI Gate Valve
14.	Datasheet of Basket Strainer
15.	Datasheet of Y Strainer
16.	Datasheet of Pipes (M.S)
17.	Data sheet of Level Switch
18.	Datasheet of Indicator
19.	Datasheet of Pressure Gauge
20.	Datasheet of Pressure Switch
21.	Datasheet of Solenoid Valve
22.	Datasheet of CI Non Return Valve
23.	Datasheet of Flow Operated Gate Valve
24.	Datasheet of Multisensor Smoke Detector
25.	Datasheet of Heat Detector, RI, Hooter, FRLS cable, MCP

S. N.	List of FPS Drawings
1.	P&I Diagram of Pump House, Hydrant & Spray System
2.	Piping Layout of Hydrant & Spray System of Raichur Substation.
3.	Nodal Diagram with Hydraulic Calculation of Hydrant System
4.	Piping Layout of Fire water pump house
	Nozzle Details of Fire water tank`
5.	Schematic Diagram for Fire Detection & Alarm System.
6.	Layout of Fire Detection & Alarm System for Control Room.
8.	Layout Drawing of Portable Fire Extinguisher.
9.	Electric Motor Driven Main Fire Water Pump Control Panel
10	MCC Panel for 2 Nos. Electrical Motor Driven Jockey Pump
11	Battery Charger cum DED Standby Fire Pump Control Panel
12	AC Distribution Board
13	DC Distribution Board
14	Local Control Panel for Deluge Valve
15	Block Diagram of Cable Schedule.
16	Piping Layout of HVW Spray System for Auto Transformer
17	Isometric of HVW Spray System for Auto Transformer
18	Pylon support detail for Auto Transformer
19	Isometric with Nodal of HVW Spray System for Auto Transformer
20	Hydraulic Calculation for Auto Transformer
26	Bill of Quantities
27.	Annunciation Panel for Pump House
28.	Annunciation Panel for Control room

SCHEDULES AND ENCLOSURES

SECTION- 5

ENCLOSURES TO SPECIFICATION

SCHEDULES TO BE FILLED UP BY THE BIDDER

- Schedule 1 Schedule of makes of Equipments
 - Schedule 2 Schedule of Deviations
 - Schedule 3 Schedule of past experience and qualifying requirements
 - Schedule 4 Schedule of performance certificates
 - Schedule 5 Schedule of type test and special tests
 - Schedule 6 Details of contact persons (technical & commercial)
 - Schedule 7 Enclosures to Specification
- ANNEXURE-A Drawings

SCHEDULE-1

MAKES OF IMPORTANT ITEMS / COMPONENTS OF EQUIPMENTS AND THEIR DETAILS

ITEM NAME	NAME OF MANUFACTURER	PLACE OF MANUFACTURE OF ITEM	PLACE OF TESTING AND INSPECTION	COMPLIANCE WITH ISO 9001 (YES/NO)

Place

Signature of the authorized representative of Bidder

Name -----

Date

Designation-----

Company seal-----

SCHEDULE – 3

SCHEDULE OF PAST EXPERIENCE AND QUALIFYING REQUIREMENT

Following is the list of earlier orders executed by us for supply of equipment / material of similar nature over the last past five years:

S.No.	Item	Brief rating	Qty	customer	Date Of order	Date of supply	Order value
-------	------	--------------	-----	----------	------------------	-------------------	----------------

Place _____ Signature of the authorized representative of Bidder
Date _____ Name-----
Designation-----
Company seal -----

Note: Continuation sheets of like size and format may be used as per the Bidder's Requirement and shall be annexed to this schedule.

SCHEDULE – 4

SCHEDULE OF PERFORMANCE CERTIFICATE

Bidder shall furnish the performance certificate of the similar equipment having
The following details:

S.No.	Item	Brief rating	Qty	Customer	Date Of supply
-------	------	--------------	-----	----------	-------------------

Place _____ Signature of the authorized representative of Bidder

Date _____

Name-----

Designation-----

Company seal -----

Note: Continuation sheets of like size and format may be used as per the Bidder's Requirement and shall be annexed to this schedule.

SCHEDULE-5

SCHEDULE OF TYPE TESTS AND SPECIAL TESTS

The following type tests and special tests as called for in the Specification shall be conducted (all type tests / special tests as mentioned in the relevant clauses of the Specification shall be listed here):

Sl no.	Clause no/ page no of Specification	Details of test	Lab in which to be conducted	Whether test to conducted free or chargeable basis. Mention 'FREE' 'CHARGEABLE'	If charges per test have been quoted for in the price bid. YES / NO
		A. Type Tests			
		1.			
		2.			
		B. Routine Tests			DO NOT
		1.			MENTION
		2.			ANY PRICE
		C. Site Tests			IN THIS
		1.			COLUMN
		2.			
		D. Special Tests (specified)			
		1.			
		2.			
		E. Other tests at works / site recommended by the Bidder			
		1.			
		2.			

NOTE:

- 1) Details have to be furnished on cables as well as accessories, each separately.
- 2) **NO PRICE SHALL BE FURNISHED IN THIS FORMAT.**

Place _____ Signature of the authorized representative of Bidder

Name-----

Date _____ Designation-----

Company seal-----

SCHEDULE-6

DETAILS OF CONTACT PERSON BOTH TECHNICAL AND COMMERCIAL

Name

Address for correspondence

Phone No.

Fax No.

Email

Place

Signature of the authorized representative of Bidder

Date

Name-----

Designation-----

Company seal -----

Note: Continuation sheets of like size and format may be used as per the Bidder's Requirement and shall be annexed to this schedule.

SCHEDULE -7

ENCLOSURES TO SPECIFICATION

DRAWINGS (ANNEXURE-D)

1. CONTROL ROOM LAYOUT OF PUSAULI SUB/STN.
2. PLAN LAYOUT OF SWITCHYARD AT PUSAULI
3. P & I DIAGRAM OF FIRE PROTECTION SYSTEM
4. OGA DRAWINGS OF TRANSFORMER

➤ **ABOVE ENCLOSED DRAWINGS ARE TENTATIVE AND MAY UNDERGO CHANGES DURING DETAILED ENGINEERING.**

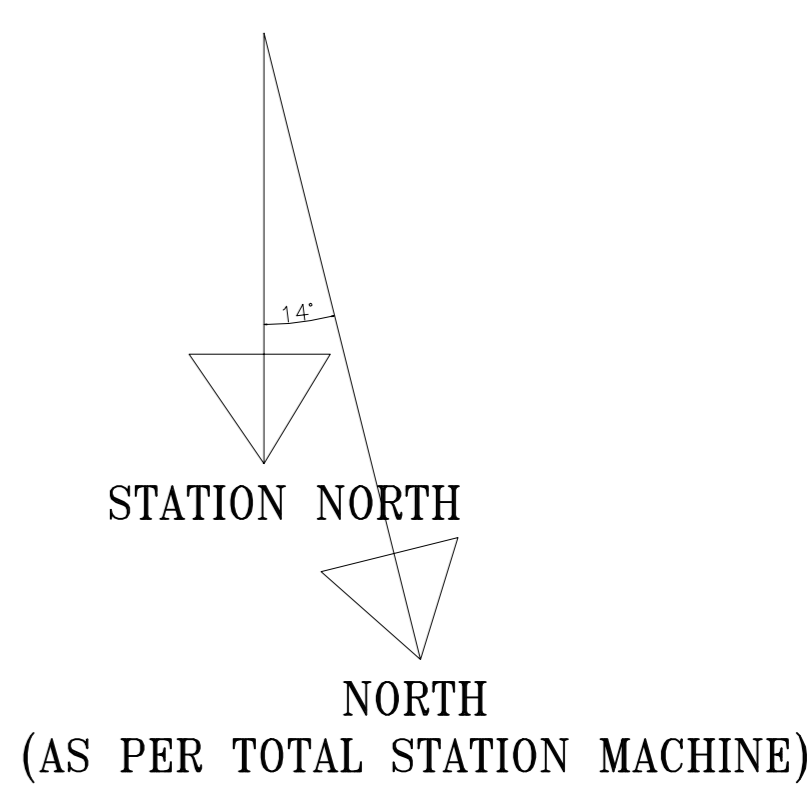
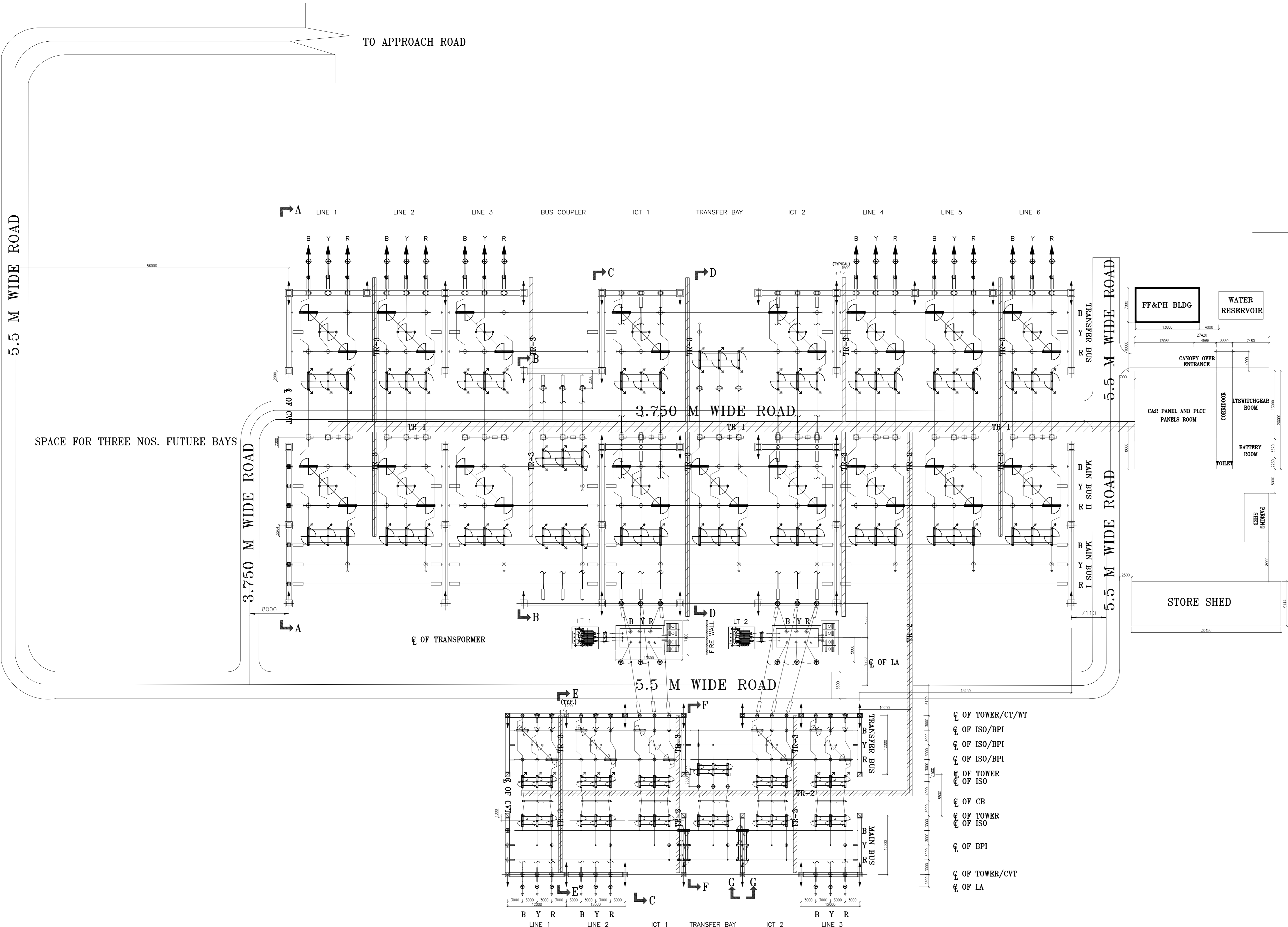

220 kV BILL OF QUANTITY

S.N.	EQUIPMENT DESCRIPTION	KV	SYMBOL	TOTAL QTY.
1a.	SF6 CIRCUIT BREAKER (3-PH), 1600A, 40 KA FOR 1 SEC.	245		09
1b.	SF6 CIRCUIT BREAKER (3-PH), 2500A, 40 KA FOR 1 SEC.	245		01
2a.	HDB ISOLATOR WITH 2 E/S 3Φ, 1600A (MECHANICALLY GANGED)	245		09
2b.	HDB ISOLATOR WITH 2 E/S 3Φ, 2500A (MECHANICALLY GANGED)	245		02
3.	HDB ISOLATOR WITH 1 E/S 3Φ, 1600A (MECHANICALLY GANGED)	245		09
4.	HDB ISOLATOR WITHOUT E/S 3Φ, 1600A, TANDEM TYPE (MECHANICALLY GANGED)	245		17
5a.	CURRENT TRANSFORMER, 1600A (1-PH), 5 CORE (EXTENDED CURRENT RATING 120%)	245		27
5b.	CURRENT TRANSFORMER, 1600A (1-PH), 5 CORE (EXTENDED CURRENT RATING 150%)	245		03
6.	216kV SURGE ARRESTOR (1-PH)	216		24
7.	WAVE TRAP (1-PH), 1600A, 0.5 mH (UNDERHUNG TYPE)	245		12
8.	4400pF CAPACITOR VOLTAGE TRANSFORMER (1-PH)	245		24
9.	220/132/33 kV, 150 MVA ICT	220/132		02
10.	245kV BUS POST INSULATOR	245		83

132 & 33 kV BILL OF QUANTITY

S.N.	EQUIPMENT DESCRIPTION	KV	SYMBOL	TOTAL QTY.
1.	SF6 CIRCUIT BREAKER (3-PH), 1250A, 31.5 KA FOR 1 SEC.	145		06
2.	HDB ISOLATOR, 1250A, 31.5 KA (MECHANICALLY GANGED MOTOR OPERATED) WITH ONE E/S	145		03
3.	HDB ISOLATOR, 1250A, 31.5 KA (MECHANICALLY GANGED MOTOR OPERATED) WITHOUT E/S	145		09
4.	HDB ISOLATOR, TANDEM TYPE, 1250A, 31.5 KA (MECHANICALLY GANGED MOTOR OPERATED) W/O E/S	145		05
5.	HDB ISOLATOR, 1250A, 31.5 KA (MECHANICALLY GANGED MOTOR OPERATED (HIGH LEVEL BEAM MOUNTED), WITHOUT E/S	145		02
6.	145kV, 800A, 120% EXTENDED CURRENT RATING 1-PHASE 5 CORE CURRENT TRANSFORMER	145		18
7.	145kV, 4400 pF, 145kV/0.110kV/0.110kV/0.110kV, 1-PHASE CAPACITOR VOLTAGE TRANSFORMER	145		12
8.	120kV, 1-PHASE SURGE ARRESTERS, 10KA, CLASS-3 (UNDERHUNG TYPE)	145		15
9.	145kV, 1250A, 0.5mH, 1-PHASE WAVE TRAP	145		06
10.	145kV BUS POST INSULATOR	145		27
11.	33kV, 630A HDB ISOLATOR	33		02
12.	HORN GAP FUSE	33		06
13.	33/0.415 kV AUXILIARY TRANSFORMER	33		02

NOTE:-
1. ALL DIMENSIONS ARE IN mm UNLESS OTHERWISE SPECIFIED.
2. SYSTEM PARAMETERS

S. NOS.	DESCRIPTION	UNIT	220	132
1.	NOMINAL SYSTEM VOLTAGE	kV	220	132
2.	HIGHEST SYSTEM VOLTAGE	kV	245	145
3.	BASIC IMPULSE LEVEL	kV	1050	650
4.	POWER FREQUENCY WITHSTAND	kVrms	460	275
5.	SWITCHING IMPULSE WITHSTAND VOLTAGE	kVrms	NA	NA
6.	CREEPAGE DISTANCE (MINIMUM)	mm/kV	25	25
7.	SYSTEM FAULT LEVEL FOR 1 SEC	KA	40	31.5

CLEARANCE TABLE :-

	220kV	132kV
MINIMUM CLEARANCE TABLE		
PHASE TO PHASE (PP)	2100mm	1300mm
PHASE TO EARTH (PE)	2100mm	1300mm
SECTION CLEARANCE (SC)	5000mm	3800mm
HEIGHT OF TUBE CENTRE LINE OF FIRST LEVEL FROM PLINTH LEVEL	5500mm	4600mm
GROUND CLEARANCE TO NEAREST PART NOT AT EARTH POTENTIAL OF AN INSULATOR SUPPORTING LIVE CONDUCTOR	2550mm	2550mm

3. CONDUCTOR DETAIL

S. NOS.	DESCRIPTION	220 kV	132 kV
1.	MAIN BUS	QUAD MOOSE ACSR	TWIN MOOSE ACSR
2.	EQUIPMENT INTERCONNECTION	4*PS AL TUBE/TWIN MOOSE ACSR MOOSE ACSR OD=114.30mm ID=97.18mm	SINGLE/TWIN MOOSE ACSR
3.	JUMPER /DROPPERS	TWIN MOOSE ACSR	SINGLE/TWIN MOOSE ACSR
4.	SHIELD WIRE	7/3.66 GALVANISED STEEL (10.98mm DIA)	

- ALL THE BUS BARS, STRUNG BUSES & EQUIPMENTS ARE PROTECTED FROM 7/3.66 GALVANISED STEEL WIRE.
- WAVE TRAP SHALL BE UNDERHUNG TYPE IN EACH FEEDER BAY OF 220kV AND 132kV SWITCHYARD.
- SUPPLY AND STRINGING OF LINE CONDUCTOR, SHIELD WIRE, INSULATOR AND HARDWARE BETWEEN DEAD END TOWER AND SUBSTATION TERMINAL GANTRY ARE NOT IN BHEL SCOPE. HOWEVER, JUMPING FOR THE RESPECTIVE EQUIPMENT & SHIELDING REQUIREMENT FOR PROTECTION OF LIVE EQUIPMENT AND JUMPERS SHALL BE IN BHEL SCOPE.
- ALL EQUIPMENT STRUCTURE (EXCEPT CIRCUIT BREAKER) ARE PIPE TYPE.

- LEGEND :-
- A → 10.98mm G.S. WIRE
 - B TENSION STRING INSULATOR
 - C SUSPENSION STRING INSULATOR
 - D CORONA END BELL

TR-1 CABLE TRENCH OF SECTION 1-1
TR-2 CABLE TRENCH OF SECTION 2-2
TR-3 CABLE TRENCH OF SECTION 3-3

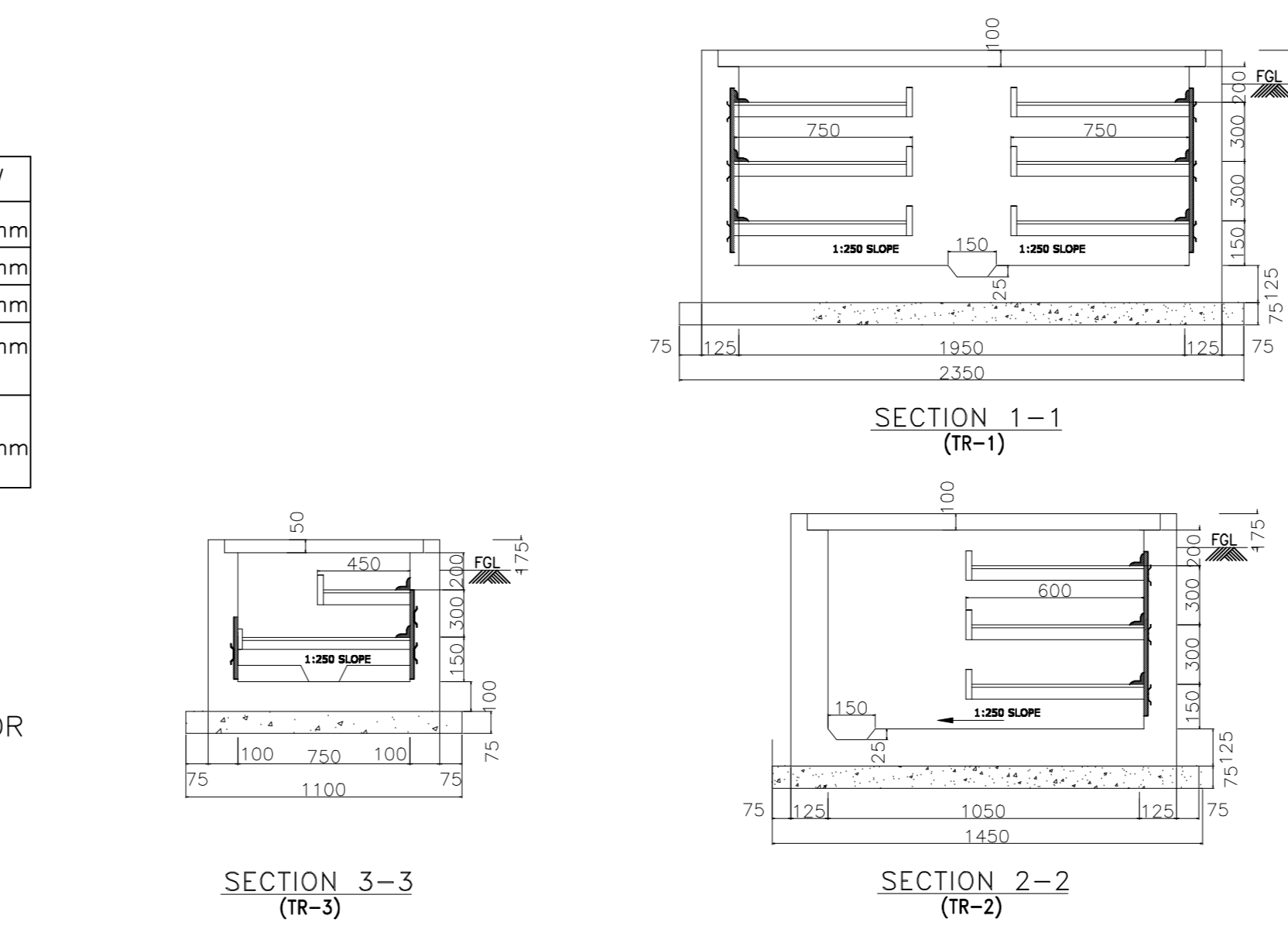

REV.	DATE	ALTERED	CHECKED	APPROVED	REV.	DATE	ALTERED	CHECKED	APPROVED	REV.	DATE	ALTERED	CHECKED	APPROVED
					02	12.08.13				01	31.05.13			

NAME OF CUSTOMER	BIHAR STATE ELECTRICITY BOARD		
JOB NO. - 374	आवक/परियोजना का नाम 220/132 kV PUSALI SUBSTATION		
STATUS OF DRAWING - CONTRACT	NAME OF PROJECT		
DISTRIBUTION OF PRINTS	 BHARAT HEAVY ELECTRICALS LTD. TRANSMISSION PROJECTS DIVISION		
REV. DATE ALTERED CHECKED APPROVED	REV. DATE ALTERED CHECKED APPROVED	REV. DATE ALTERED CHECKED APPROVED	REV. DATE ALTERED CHECKED APPROVED
SIGNATURE/TITLE		DATE	
LAYOUT PLAN FOR 220/132 kV SWITCHYARD		ड्राइंग.क./DRAWING NO. TB-0-357-510-002	
पृष्ठ क्र./SHEET No. 01		कुल पृष्ठ/NEXT SHEET 02	

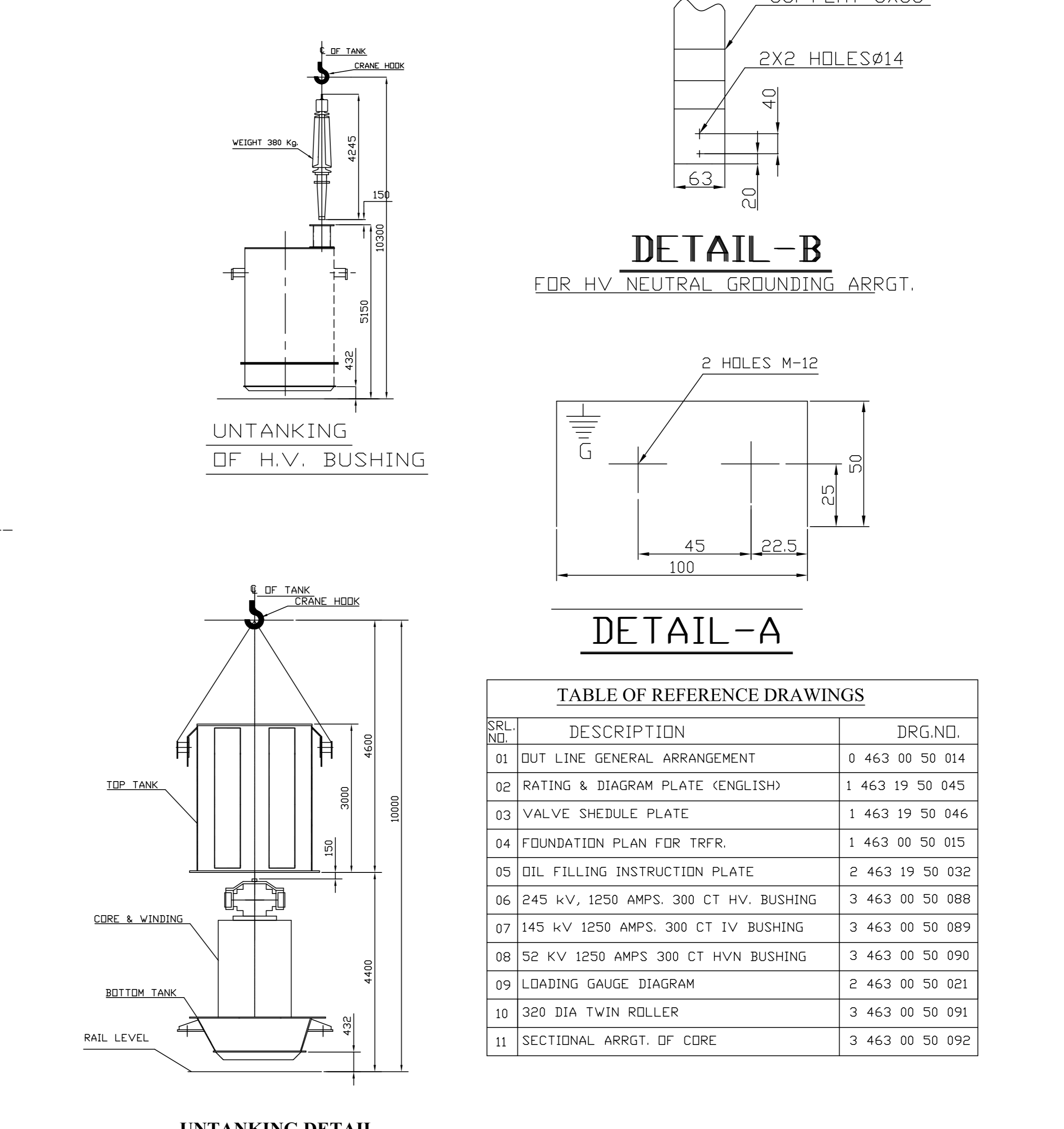
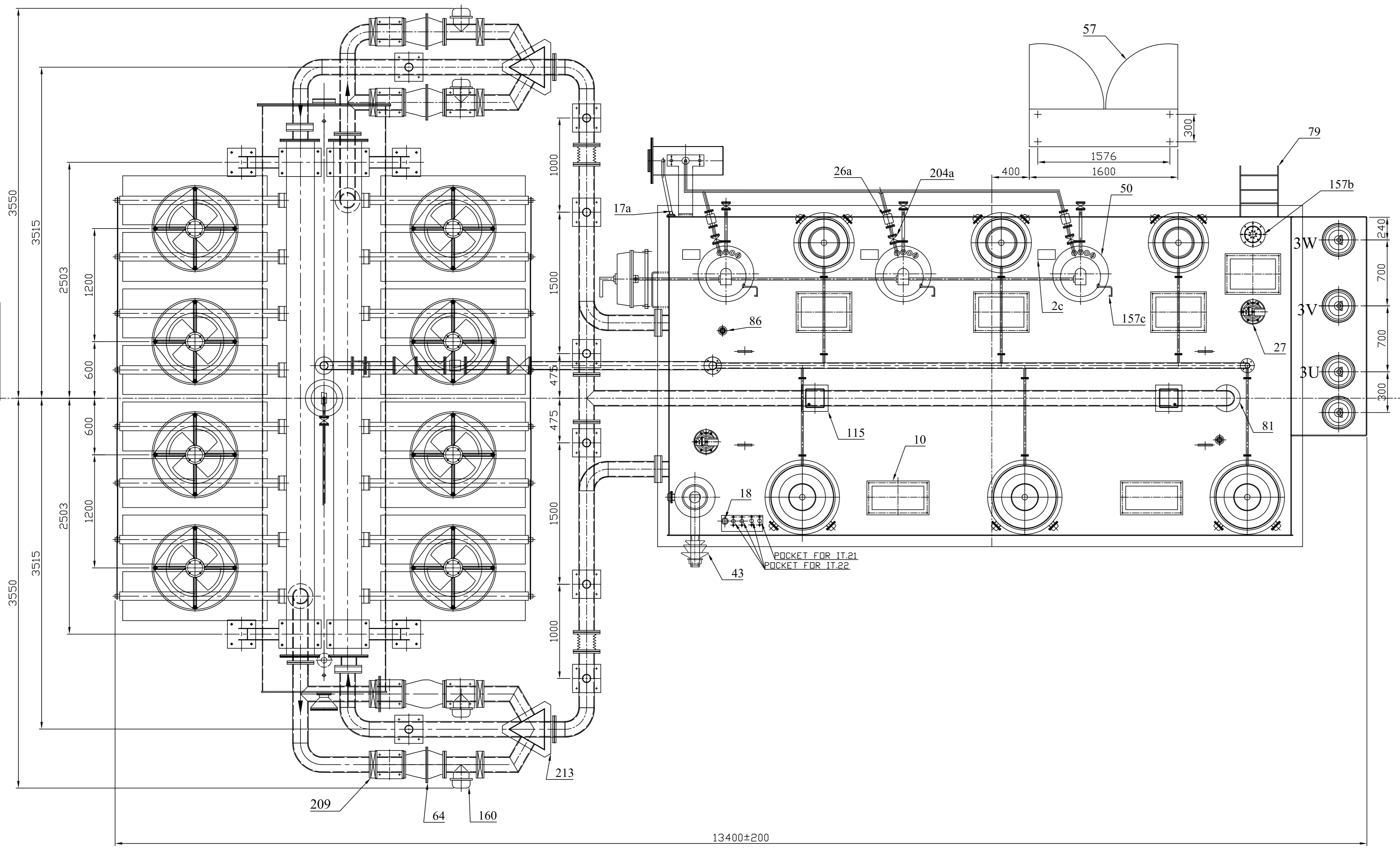
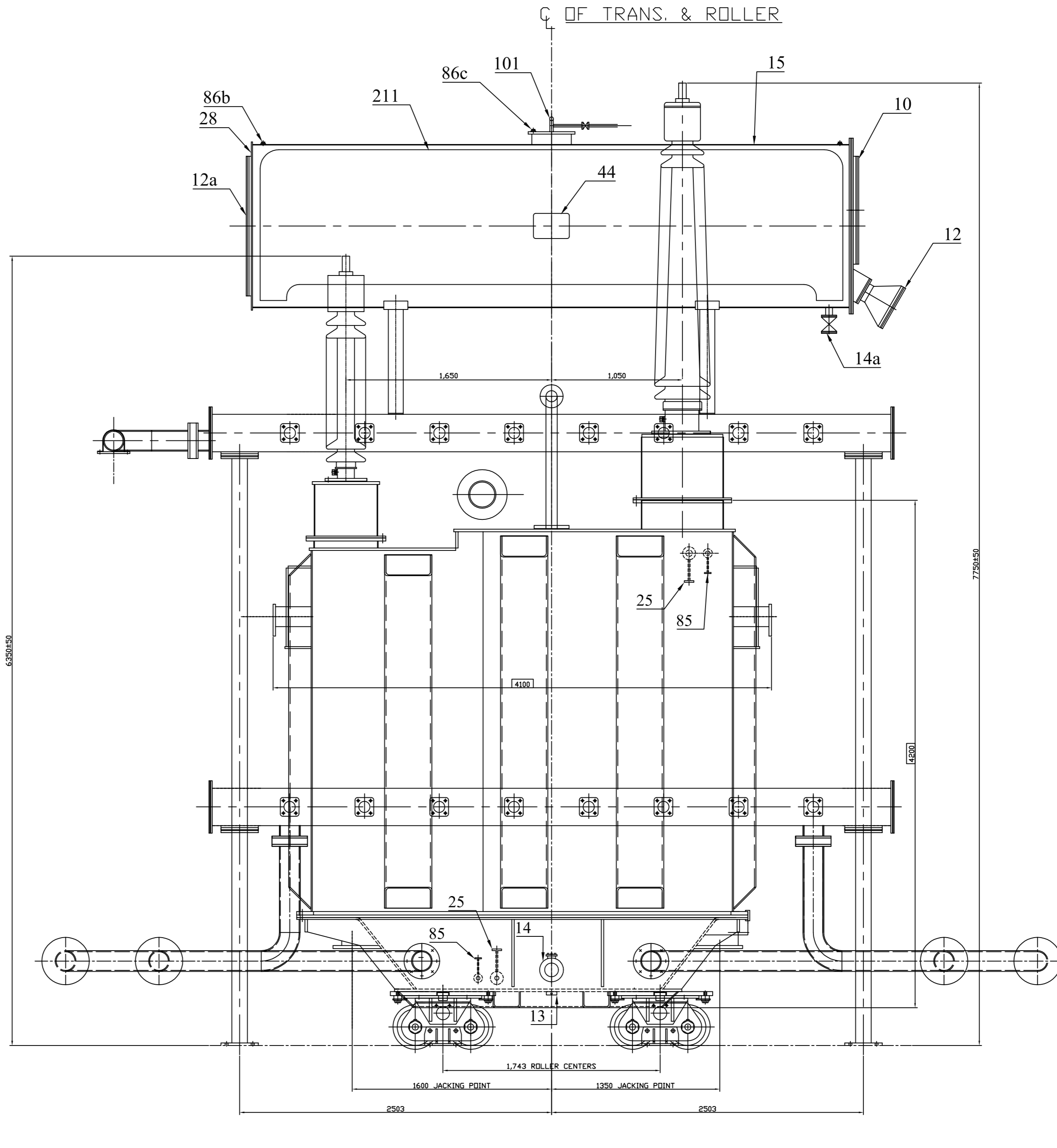
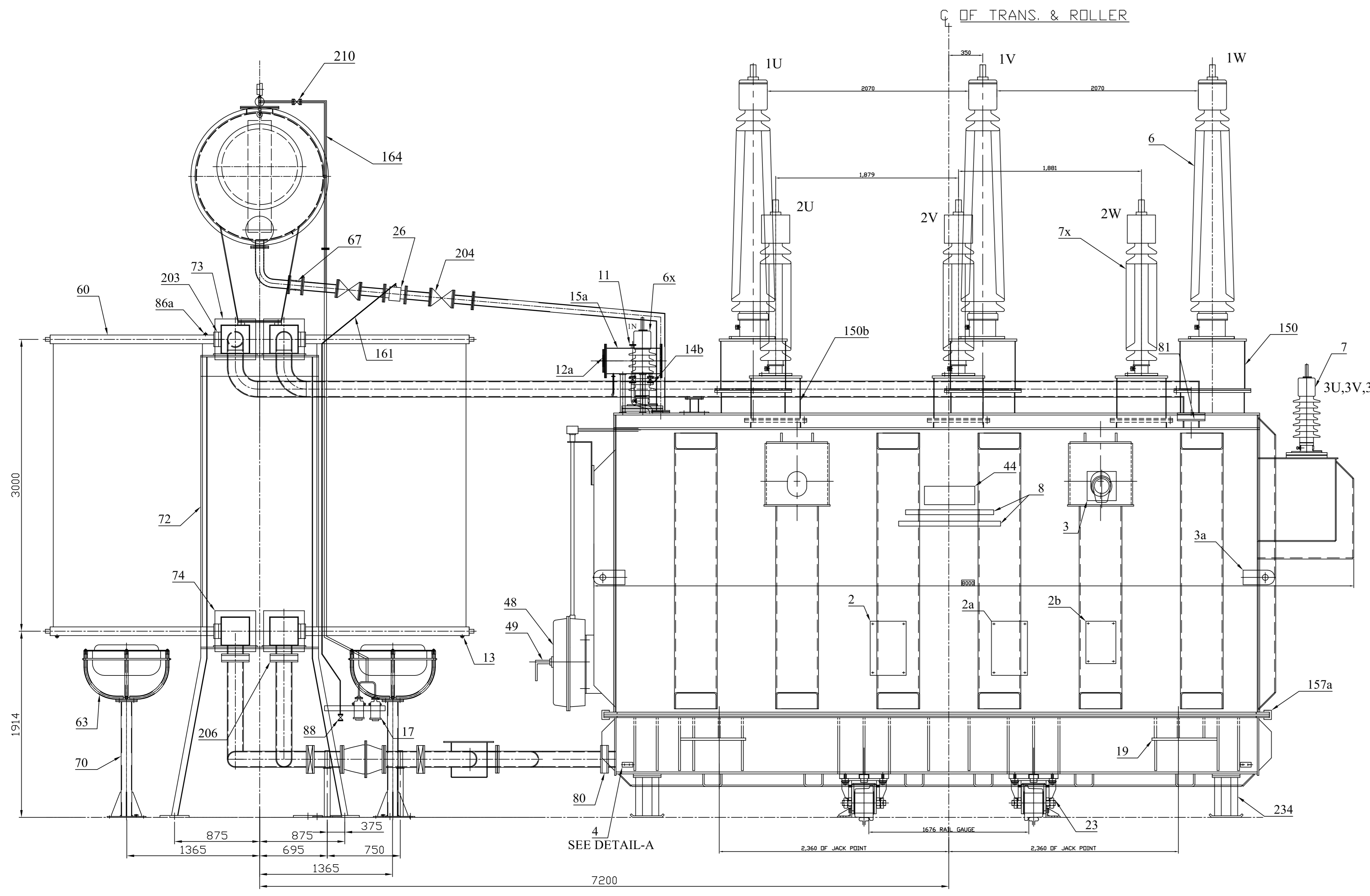

TABLE OF FITTINGS		
ITEM NO.	DESCRIPTION	QTY.
2	COMBINED RATING & DIAGRAM PLATE (HINDI & ENGLISH)	01NO.
2a	VALVE SCHEDULE PLATE	01NO.
2b	OIL FILLING INSTRUCTION PLATE	01NO.
2c	CAUTION PLATE FOR DLTC	03NO.
3	LIFTINGS BOLLARDS	04NO.
3a	LASHING LUGS	04NO.
4	EARTHING TERMINAL ON TANK	04NO.
5	H.V. BUSHING 245 KV, 1250 AMP.	03NO.
6x	H.V. NEUTRAL BUSHING 52 KV, 1250 AMP.	01NO.
7	L.V. BUSHING 52 KV, 1250 AMP.	03NO.
7x	I.V. BUSHING 145 KV, 1250 AMPS.	03NO.
8	NAME PLATE (HINDI & ENGLISH)	1+1NO.
10	INSPECTION COVERS ON TANK, COVER & MAIN CONSERVATOR (MAX. WT.-25KG)	18NO.
11	OIL FILLING HOLE ON CONSERVATOR FOR DLTC 25 NB.	01NO.
12	MAGNETIC OIL GAUGE WITH LOW OIL LEVEL ALARM FOR MAIN CONSERVATOR	01NO.
12a	PRISMATIC OIL GAUGE FOR MAIN CONSERVATOR	01NO.
12b	PRISMATIC OIL GAUGE FOR DLTC CONSERVATOR	01NO.
13	DRAIN PLUG ON TANK/RADIATORS PIPE WORK & OIL REVERSE FLOW STOPPING DEVICE	20NO.
14	DRAIN VALVE ON TANK (100 NB. B/F)	01NO.
14a	DRAIN VALVE ON MAIN CONSERVATOR (50 NB. B/F)	01NO.
14b	DRAIN VALVE FOR DLTC CONSERVATOR (15 NB. GUN METAL	01NO.
15	MAIN OIL CONSERVATOR AIR CELL TYPE	01NO.
15a	DLTC OIL CONSERVATOR	01NO.
17	DEHYDRATING BREATHER FOR MAIN CONSERVATOR	02NO.
17a	DEHYDRATING BREATHER FOR DLTC CONSERVATOR	01NO.
18	THERMOMETER POCKETS WITH ORDINARY THERMOMETER ON TANK COVER & HEADERS (WITH CAPATIVE SCREW ON TOP)	1+NO.
19	JACKING LUGS	04NO.
21	DTI (150mm DIAL SIZE) WITH REPEATER & RTD	01NO.
22	WTI (150mm DIAL SIZE) WITH REPEATER & RTD	03NO.
23	ROLLER BI-DIRECTIONAL Ø 320 TWIN WITH STOPPER BRACKET ARRGT.	04NO.
25	FILTER VALVE ON TANK & HEADER (50 NB.) GUN METAL (USE FOR OIL FILLING) WITH 40 MM. MALE THREADED ADAPTER	2+4NO.
26	BUCHHOLZ RELAY (BONB) DOUBLE FLAT TYPE WITH ALARM & TRIP CONTACTS WITH TEST AND BLEED VALVE	01NO.
26a	OIL SURGE RELAY FOR DLTC (BHEL MAKE)	03NO.
27	PRESSURE RELIEF DEVICE (150 NB) WITH TRIP CONTACTS, SPRING LOADED TYPE	02NO.
28	END COVER FOR MAIN CONSERVATOR	01NO.
43	33 KV. POST INSULATOR FOR HV NEUTRAL GROUNDING STRIPS	2NO.
44	BILANGUAL COMPANY'S HONDGRAM (ON TANK & MAIN CONSERVATOR)	1+1NO.
48	MOTOR DRIVING GEAR (BHEL MAKE)	01NO.
49	HAND OPERATING HANDLE	01NO.
50	DN LOAD TAP CHANGER WITH MOTOR DRIVING GEAR BOX (BHEL MAKE - MR TYPE)	03NO.
57	MARSHALLING KIOSK	01NO.
60	RADIATORS	16NO.
63	FAN & MOTOR (24") WITH GALVANIZED BLADES, GUARDS & BLOWER CASING	04NO.
64	OIL PUMP & MOTOR (150NB)	01NO.
67	FLEXIBLE JOINT(150NB,80NB)	2+1NO.
70	FAN SUPPORT	08NO.
72	RADIATOR & HEADER SUPPORT (A FRAME)	08NO.
73	TOP HEADERS	02NO.
74	BOTTOM HEADERS	02NO.
77	RADIATOR TIE BAR	02NO.
79	LADDER WITH SAFETY FLAP	01NO.
80	OIL INLET VALVE (150NB BUTTERFLY TYPE) ON BOTTOM TANK	02NO.
81	OIL OUTLET VALVE (20NB BUTTERFLY TYPE) ON TOP COVER	01NO.
85	SAMPLING VALVE (25 NB) ON TANK	02NO.
86	AIR RELEASE VALVE (15 NB) ON COVER	02NO.
86a	AIR RELEASE PLUG ON RADIATORS, HEADERS, PUMP & MOTOR PIPE WORK & OIL REVERSE FLOW STOPPING DEVICE	26NO.
86b	AIR RELEASE PLUGS (3/4" BSP) ON MAIN CONSERVATOR	02NO.
86c	AIR RELEASE PLUG (1/4" BSP) ON MAIN CONSERVATOR	01NO.
88	BUCHHOLZ GAS RELEASE PET COCK (6 NB)	01NO.
101	PRESSURE GAUGE ON MAIN CONSERVATOR (0-56KG/ CMSD)	01NO.
115	LOCKING ARRGT.	02NO.
150	HV TURRET	03NO.
150a	I.V. TURRET	03NO.
157a	EARTHING CONNECTION BETWEEN TOP TANK & BOTTOM TANK	02NO.
157b	EARTHING CONNECTION BETWEEN TANK & TO CORE	01NO.
157c	EARTHING CONNECTION BETWEEN TAP CHANGER TO TANK COVER	03NO.
160	OIL FILL INDICATOR 150 MM. DIAL SIZE WITH ALARM CONTACTS	02NO.
161	BUCHHOLZ GAS RELEASE PIPE 6 NB	01NO.
164	BREATHER PIPE (15 NB. PIPE)	02NO.
203	RADIATOR VALVE (80 NB BUTTERFLY TYPE)	24NO.
204	CONSERVATOR VALVE (80 NB FOR MAIN CONS.) GUN METAL	2NO.
204a	VALVE FOR DRAIN & SAPLING OF DLTC DIVERTOR 25 NB GUN METAL	03NO.
206	VALVE FOR DISCONNECTING RADIATOR BANK (150 NB B/F)	04NO.
209	VALVE FOR DISCONNECTING PUMP & MOTOR (150NB B/F)	08NO.
210	VALVE (15 NB) FOR BREATHER CONNECTION ON MAIN CONSERVATOR(GUN METAL)	01NO.
211	FLEXIBLE SEPARATOR (AIR CELL) FOR MAIN CONSERVATOR	01NO.
213	OIL REVERSE FLOW STOPPING DEVICE SUBTABLE FOR 150 NB. PIPE	02NO.
231	EARTHING STRIP FOR HV(O) BUSHING (10 TK. X 50)	01NO.
234	PROP. ASSY.	04NO.

- NOTES:-**
- WHEN REFERING THIS DRG. STATE 150 MVA & W.DND. 70619P17200
 - DIMENSIONS MARKED THIS ARE OVER ALL SHIPPING DIMENSIONS EXCLUSIVE OF PACKING.
 - PVC, SWA, PVC ARMORED CABLE WIRING UP TO MARSHALLING BOX ARE SUPPLIED BY BHEL, BUT NOT SHOWN IN THIS DRG. FOR CLARITY.
 - FOUNDATION BOLTS, NUTS & WASHERS ETC. ARE SUPPLIED BY BHEL.
 - OUT SIDE PAINTING SHALL BE EPOXY PAINT TO SHADE NO 632 OF IS-5
 - FINAL WEIGHTS SHALL BE CALCULATED AFTER COMPLETION OF MANUFACTURING DRGS.

TABLE OF REFERENCE DRAWINGS		
SRL. NO.	DESCRIPTION	DRG.NO.
01	OUT LINE GENERAL ARRANGEMENT	0 463 00 50 014
02	RATING & DIAGRAM PLATE (ENGLISH)	1 463 19 50 045
03	VALVE SCHEDULE PLATE	1 463 19 50 046
04	FOUNDATION PLAN FOR TRFR.	1 463 00 50 015
05	OIL FILLING INSTRUCTION PLATE	2 463 19 50 032
06	245 kv, 1250 AMPS. 300 CT HV. BUSHING	3 463 00 50 088
07	145 kv 1250 AMPS. 300 CT IV BUSHING	3 463 00 50 089
08	52 kv 1250 AMPS 300 CT HVN BUSHING	3 463 00 50 090
09	LOADING GAUGE DIAGRAM	2 463 00 50 021
10	320 DIA TWIN ROLLER	3 463 00 50 091
11	SECTIONAL ARRGT. OF CORE	3 463 00 50 092

APPROXIMATE WEIGHT		
DESCRIPTION	WT.IN KG.	
CORE AND WINDING	80000	
OIL REQD FOR FIRST FILLING (61000 LTRS.)	55000	
TANK AND FITTINGS WITH ACCESSORIES	45000	
SHIPPING WEIGHT (GAS FILLED)	105000	
TOTAL WIGHT WITH OIL AND FITTINGS	180000	

LOA NO.:- 186/ADB/26/ADB/2010

TYPE OF PRODUCT: 90/120/150 MVA 220/132/33 KV ONAN/ONAF/OFAP COILED AUTO TRANSFORMER (S/S:- PUSAUILL & 220 KV BAY EXT. DEHRI)

STATUS OF DRAWING: U

NAME OF CUSTOMER/PROJECT: M/S:- BSEER PUSAUILL

DISTRIBUTION OF PRINTS: TRE-1, TRP-1, BAY1&2-2, BAYS-4, JHANSI

DATE: 18.04.13

NO. OF SHEETS: 01

SCALE: ---

WEIGHT (KG): ---

REF. TO ASSY. NO.:

ITEM NO. OF ITEM: ---

TITLE: OUTLINE GENERAL ARRGT.

DRAWING NO. 0 463 00 50 014

SHEET NO. 01 NO. OF SHEETS 01

REV	DATE	ALTERED	CHECKED	REV	DATE	ALTERED	CHECKED	REV	DATE	ALTERED	CHECKED	REV	DATE	ALTERED	CHECKED

INVENTORY NO. 17
STION. & DATE REF. DRG. NO. PDNO14724.DWG
THE INFORMATION ON THIS DOCUMENT IS THE PROPERTY OF BHARAT HEAVY ELECTRICALS LIMITED. IT MUST NOT BE USED DIRECTLY OR INDIRECTLY IN ANY WAY DETRIMENTAL TO THE INTEREST OF THE COMPANY.

SPRAY SYSTEM FOR 2 NOS. TRANSFORMERS IN BHEL SCOPE

LEGEND

- ALARM
- GATE VALVE NORMALLY OPEN
- GATE VALVE NORMALLY CLOSED
- NON-RETURN VALVE
- GLOBE VALVE NORMALLY OPEN
- GLOBE VALVE NORMALLY CLOSED
- FLOAT OPERATED GATE VALVE
- TEST VALVE
- PRESSURE GAUGE
- PRESSURE SWITCH
- LEVEL GAUGE
- LEVEL SWITCH
- BASKET STRAINER
- FLOAT OPERATED LEVEL GAUGE
- Y-TYPE STRAINER
- WATER MOTOR GONG
- REDUCER
- THREE WAY COCK/ VALVE
- VENT
- DRAIN
- OUT DOOR HYDRANT
- INDOOR HYDRANT
- QUARTZOID BULB DETECTOR
- HVW SPRAY NOZZLE
- PUMP
- WATER LINE
- DELUGE VALVE

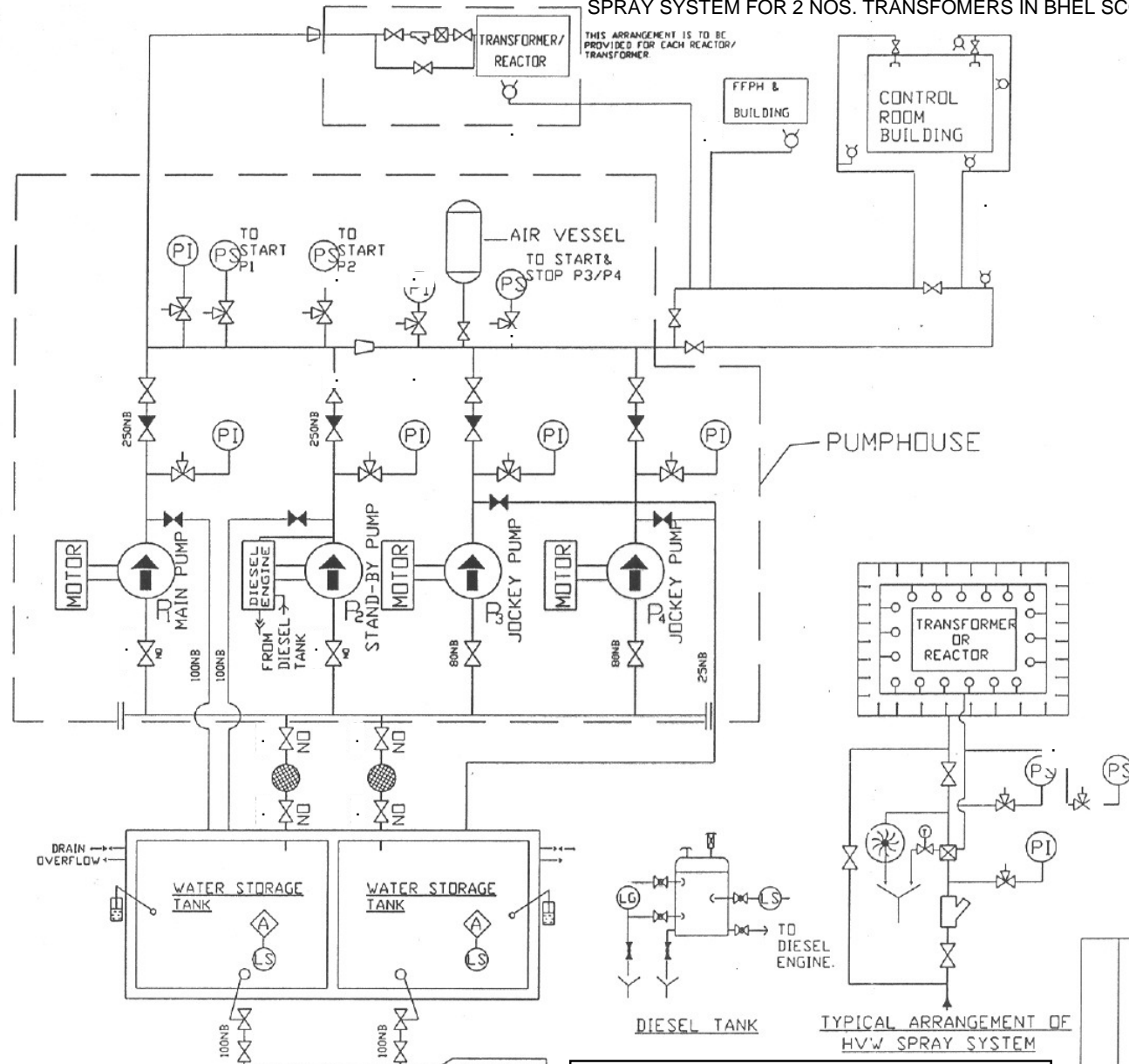

- NOTES: 1. THE HYDRANT POINTS FOR TRANSFORMER/ REACTOR SHALL BE LOCATED AT LEAST 20M AWAY FROM THEM.
2. AS SAFETY MEASURE, A WARNING PLATE SHALL BE PLACED NEAR HYDRANT POINTS FOR TRANSFORMER/ REACTOR TO CLEARLY INDICATE THAT WATER SHALL BE SPRAYED ONLY AFTER ENSURING THAT THE POWER TO THE TRANSFORMER/ REACTOR WHICH IS ON FIRE IS SWITCHED OFF AND THERE ARE NO LIVE PART WITHIN 20 M. DISTANCE OF THE PERSONNEL USING THE HYDRANT.

Water tap off provision within 10 m of FFPH building in Client's scope

RECOMMENDED						BIHAR STATE ELECTRICITY BOARD (BSEB)					
						PROJECT: PUSAULI SWITCHYARD					
DATE		DRAWN		CHKD.		APPD.		DRG. NO.		REV.	
								NTS/C/ENGG/STD/FP/1		0	