



3BHEL  
GOINDWAL

TERMS AND CONDITIONS FOR  
(Tender Enquiry No. 1314-188 dated: 01.03.2014 Due date of opening 15.03.2014)  
Item: Ball Bearings

C1 **Inviting Quotations:**

Sealed Bid submission in two part Part-I: Techno-commercial bid and Part-II: Price bid are hereby invited for manufacturing and supply of Ball Bearings as per BHEL Drawings, Matl Standards (as per latest revision applicable), TDCs and other technical documents referred in these documents. The relevant documents are attached with the Enquiry.

The two bids should be submitted in **separate sealed inner envelopes** duly mentioning the detail as follows:

Bid	Description	Superscription on envelope	Min documents to be submitted
Part-I	Techno-Commercial bid in response to tender enquiry no. 1314-188 Dated 01.03.2014	PART-I: "Techno-Commercial Bid" Tender Enquiry no. 1314-188 Dated 01.03.2014 Due date of opening: 15.03.2014 Sender :	1. Acceptance of all terms and conditions. 2. Un-priced (Prices not filled) format showing taxes and duties structure.
Part-II	Price bid in response to tender enquiry no. 1314-188 Dated 01.03.2014	PART-II: "Price Bid" Tender Enquiry no. 1314-188 Dated 01.03.2014 Sender:	Price bid duly filled prices in words also along with same taxes and duties as mentioned in unpriced bid.

All the sealed envelopes should be put in an outer envelope clearly mentioning Tender Enquiry No. 1314-188 Dated 01.03.2014, item description as "Ball Bearings" and due date of opening as 15.03.2014 time 1530 hrs on it.

**Following point need to be noted by manufacturers and dealers/agents as follows-**

For manufacturers-

**Procurement shall be preferred from manufacturers. In case manufacturer insist on engaging a dealer/ agent, such dealer/agent is not allowed to represent more than one manufacturer.**

For dealers/agents -

**In case of dealers/agents, Authorized dealer certificate is required from original manufacturer. In case bids are received from dealer/agent and manufacturer both, bid submitted by dealer will be rejected. A dealer representing more than one manufacturer will be rejected. We require cage material of bearings, to be STEEL only. Bidders should clearly mention about cage material of bearings in quotation. The quotation of other cage material will not be accepted.**

**Part-I: Techno-Commercial bid should contain**

- Acceptance of Techno-Commercial terms and conditions should be attached next. This can be attached either by signing each page of terms and conditions or a confirmation statement. If nothing is mentioned for any term, it shall be summarily concluded that the same is acceptable and no representation whatsoever shall be entertained later on.
- Un-priced bid as per format attached. All details, i.e. whether quoted for item, duties and taxes etc. should be filled.** Price Bid format without the price shall be provided with Part I.

Quotations shall reach us by 1500 Hrs and Part-I shall be opened at 1530 Hrs on due date. Late offers are liable to be rejected, so please ensure to send the quotation well within due date. Based on evaluation of techno-commercial offers, Price bids of bidders who qualify from techno-commercial evaluation shall be opened. BHEL may decide to open the Price bid same day at 1700 hrs, if all the vendors have accepted the entire tender terms and conditions. If not opened on the same day, all qualifying bidders shall be notified for date of opening of Price bids.



3BHEL  
GOINDWAL

TERMS AND CONDITIONS FOR  
(Tender Enquiry No. 1314-188 dated: 01.03.2014 Due date of opening 15.03.2014)  
Item: Ball Bearings

Sealed Tenders can be dropped in the tender box labeled as 'Tender box for MM contracts'. This tender box is located at the entrance of Admin block BHEL Goindwal. For any clarification you can contact on email id **tendermm@bhelivp.in**. Tender may be handed over to Sh Gurbax Singh/ Head MM or Sh Osho Katyal in case of bulky tenders. Fax (01889222148)/ email (tendermm@bhelivp.in) offers received in time shall be considered only when such offers are complete in all respects.

**Part II: Price Bids:**

**Price bid in the format attached.** Preferably the price bid envelop should contain ONLY the price bid. Further, if even the same conditions are mentioned in the Part-II, but after scrutiny of Part-I, the bidder has agreed to BHEL terms, the same shall be binding and any such condition found in Part-II shall in no case be discussed.

**No Other format shall be used for submitting the price bid.** Any variation in Unit of Supply other than that mentioned in the Price bid format shall not be accepted.

Anything other than price mentioned in the price bid shall be considered invalid.

Duties shall be payable extra against ED Gate Pass valid for CENVAT benefit.

Price quoted shall be firm and not subject to any escalation during the contract execution.

Price should be quoted on FOR Destination Goindwal Sahib basis. If not mentioned, it shall be concluded that the offer is on FOR Destination Goindwal Sahib basis. In case rates are Ex-Works basis, loading of expenses i.e., freight, transit insurance shall be done by BHEL at its discretion to arrive at Landed prices. Comparison shall be done at Landed cost to BHEL.

All amounts shall be indicated both in words as well as figures. Where there is difference between amount quoted in words and figures, amount quoted in words shall prevail.

Tenders should be free from CORRECTION AND ERASURES. Corrections if any must be attached. Sealed Tenders can be dropped in the tender box labeled as 'Tender box for MM contracts'. This tender box is located at the entrance of Admin block BHEL Goindwal.

**C2 Validity of offers:**

Offers shall be valid for 60 days from due date of opening. In case of extension of due date of opening, the offers validity shall be extended accordingly.

**C3 Scope of supply:**

Material shall be supplied as per the applicable latest Technical Delivery Conditions (TDC)/ Material Standard requirements/BPS/Drawing and other requirement as given in the Purchase Order. National & International material Standards shall have to be arranged by vendors themselves. It should be noted that BHEL will compare prices for individual item and order will be given to L1 vendor for L1 item irrespective of tender quantity and value.

For supply of Ball Bearings +/- 10% quantity may vary.

**C4 COUNTER OFFERS**

BHEL reserves the right to negotiate with L1 or re-float the tender in case the quoted prices are not acceptable. BHEL will not give counter-offer to vendors other than L1, in order to have broader vendors base for ensuring timely delivery.

**C5 REPLACEMENT OF REJECTION:**

If the material is rejected due to defective workmanship during inspection or at the time of actual use, the rejected material shall be replaced by the supplier. Corresponding quantity shall be treated as unsupplied against respective purchase order till replacement is received at BHEL. If the material is found defective and rejected during use for which payment has already been released the rejected



3BHEL  
GOINDWAL

TERMS AND CONDITIONS FOR  
(Tender Enquiry No. 1314-188 dated: 01.03.2014 Due date of opening 15.03.2014)  
Item: **Ball Bearings**

quantity shall be supplied free of cost by the vendor within a month of intimation of the rejection by BHEL.

C6 **Terms of payment:**

C6.1 Due payment against supplies received shall be due after 30 days of receipt and acceptance of material and shall be paid within next 15 days period. In case of deviation, loading shall be done at SBI base rate + 6% at time of opening of Part 1.

C6.1.1 Commercial invoice (in duplicate).

C6.2 Original VAT invoice valid for claiming input tax credit.

C6.3 Compliance Certificate & Inspection clearance certificate released at the time of Pre-Despatch inspection at vendor's works, if any.

C6.4 Above documents should include your Registration numbers such as ECC no, PAN no, CST no, TIN/ VAT nos. etc.

C6.5 BHEL will not be responsible for delays in release of payment on account of discrepancies in documentation, so vendor has to ensure compliance to documentation requirement

**C6.6 BHEL releases payment through EFT mode. Vendor can provide the necessary details by obtaining format before release of payment while supplying the material**

C7 **Delivery schedule:**

Supplies shall be affected and completed as per schedule mentioned in the POs. All material to be supplied within **Four Months** from PO placement date. Further, BHEL may release delivery schedule from time to time based upon our requirement. Vendor shall be required to complete the order as per the PO/schedule requested.

C8 **INSPECTION:**

a. All required tests shall be carried out by vendor at no extra cost. Relevant TCs shall accompany the consignment. BHEL may decide to inspect itself/arrange third party at vendors' works itself as and when necessary with prior intimation to the vendor. No additional charges shall be claimed for such inspections.

b. Vendor will give inspection call sufficiently in advance considering the delivery period stipulated in the purchase order.

c. Material Test Certificates (MTC), Inspection reports and Compliance/Guarantee Certificate are to be provided along with the supplies.

d. Latest applicable revisions of standards/procedures to be referred.

e. Any inspection carried out before supply by vendor/incoming stage at BHEL not withstanding, if any defect/non-conformity is noted during processing, the same shall be attended/replaced by vendor at no extra cost.

C9 **GUARANTEE:**

Vendor shall give a guarantee of 18 months from the date of dispatch or 12 months from use, against manufacturing defects, whichever is earlier.

C10 **Access to Manufacturing Premises:**

For evaluation & during the period of execution of contract, authorized representatives of BHEL shall be allowed free access to the manufacturing facilities for the purpose of inspection or monitoring the progress of contract. This access will also be extended to representatives of BHEL's customers accompanying the authorized representative/s of BHEL, if our contractual requirements with our customers call for the same.



3BHEL  
GOINDWAL

TERMS AND CONDITIONS FOR  
(Tender Enquiry No. 1314-188 dated: 01.03.2014 Due date of opening 15.03.2014)  
Item: Ball Bearings

C11 **Risk Purchase**

BHEL shall be entitled to terminate the contract with any vendor and to purchase elsewhere at the risk and cost of the vendor, either the whole or part thereof which the supplier has failed to deliver within the time stipulated as aforesaid. Vendor shall be liable for the losses, which BHEL may sustain by way of such risk purchase in addition to aforesaid penalty for delayed delivery. Purchases made from any other vendor at its quoted rates shall be made and the difference of rates of defaulter vendor and new vendor shall be deducted from running bills of the vendor who has failed to deliver.

C12 **Penalty for late delivery**

'Time is the essence of the contract'. As such, delivery of goods specified in the Purchase Orders shall be made within the time limit prescribed therein. Penalty for late delivery clause will be applicable for delayed supplies @ 0.5% per week or part thereof subject to a maximum of 10%. **Once the delivery period mentioned has expired, BHEL may or may not take the delivery of item.**

C13 **SUB-CONTRACT:**

The purchase order or any part thereof shall not be sub-contracted, assigned or otherwise transferred without previously obtaining the BHEL's consent in writing

C14 **MSE Certification**

If the bidder is registered as any of Micro/Small enterprise as defined in Micro Small and Medium Enterprises Development Act, 2006; a copy of registration certificate to be attached.

C15 **Preferences to MSES**

Preferences as mentioned in "Public Procurement Policy for Micro and Small Enterprises (MSEs) Order, 2012" shall be given to Micro and Small enterprises.

Main points which are mentioned in the above order are as follows:

- 20% Procurement of the tender value shall be made from MSE (Micro, Small Enterprises) firms.
- 4% from the above mentioned 20% procurement quantity shall be procured from MSE's owned by SC /ST's. Failure to participate by any MSE owned by SC/ST's this 4% quantity shall be procured from other MSEs.
- EMD shall be exempted for MSE's. All these benefits are subject to production of all statutory documents
- In tender, participating Micro and Small Enterprises quoting price within price band of L1+15 per cent shall also be allowed to supply a portion of requirement by bringing down their price to L1 price in a situation where L1 price is from someone other than a Micro and Small Enterprise and such Micro and Small Enterprise shall be allowed to supply up to 20 per cent of total tendered value. In case of more than one such Micro and Small Enterprise, the supply shall be shared proportionately (to tendered quantity).

All these preferences are applicable subject to the submission of applicable certificates (i.e. District Industries Centers or Khadi and Village Industries Commission or Khadi and Village Industries Board or Coir Board or National Small Industries Corporation or Directorate of Handicrafts and Handloom or any other body specified by Ministry of Micro, Small and Medium Enterprises).

"MSE suppliers can avail the intended benefits only if they submit along with offer, attested copies of either EM II certificate having deemed validity (Two years from the date of issue of acknowledgement in EM-II) or valid NSIC certificate or EM II certificate along with CA certificate (Format enclosed as per Annexure - I) applicable for the year, certifying quantum of investment in plant and machinery within the permissible limit as per the act for relevant status (Micro or small) where the deemed validity of EM II is over. Date to be reckoned for determining the deemed validity will be the last date of technical bid submission. Non submission of such documents will lead to consideration of their bids at par with other bidders and MSE status of such suppliers shall be shifted to Non MSE supplier till the supplier submits these documents".

**NOTE : It is reiterated that no clarifications for submission of MSE documents after opening of Part -I will be asked.**



3BHEL  
GOINDWAL

TERMS AND CONDITIONS FOR  
(Tender Enquiry No. 1314-188 dated: 01.03.2014 Due date of opening 15.03.2014)  
Item: Ball Bearings

C16 **Force Majeure:**

If at any time during the continuance of the contract, the performance in which or in any part by either party of any obligations under the contract are prevented or delayed by reason of any war, hostilities, acts of public enemy, civil commotion, sabotage, fires, explosions, epidemics, quarantine restrictions, or acts of God (hereinafter referred to "an events") then provided the notice of happening of any such event is given by either party to the other within 21 days of the occurrence thereof, neither party shall by reason of such event be entitled to terminate the contract nor shall either party have any claim for damages against the other in respect of such non-performance and delay in performance and delivery under the contract shall be resumed as soon as practicable after such event has come to an end or ceased to exist. If the performance in whole or part of any obligation under the contract is prevented or delayed by reason of any such event, claims of extension of time shall be granted for periods considered reasonable by BHEL subject to prior notification by the vendor to BHEL of the particulars of the event and supply to BHEL, if required, of any supporting evidence. Any waiver of time in respect of partial instalment shall not be deemed a waiver of time in respect of remaining deliveries.

C17 **Arbitration:**

In the event of any dispute and/or difference arising between the Vendor and BHEL as to interpretation and/or execution of the contract and/or the respective rights and liabilities of the parties, such disputes and/or differences shall be referred to the sole arbitrator nominated by BHEL. The provisions of the Indian Arbitration Act and the rules there under shall apply to such arbitration. The award passed by the arbitrator shall be final and conclusively binding on all the parties.

C18 **Jurisdiction:**

The court of the place from where the purchase order is issued shall alone have jurisdiction to decide any dispute arising out of or in connection with the purchase order.

C19 **Banned Firms**

The offers of the bidders who are on the banned list as also the offer of the bidders, who engage the services of the banned firms, shall be rejected. The list of banned firms is available on BHEL website [www.bhel.com](http://www.bhel.com).

C20 **Clarifications:**

The correspondence exchanged against the tender from both tenderer and BHEL through email are considered as valid document legally though it is not signed. It is treated as valid confirmations made on behalf of the respective company and very much comes under the legal ambit of the business transaction and hence it is binding on both the parties to the business. Any transaction pertaining to the tender from both the parties of business done round the clock irrespective of the office or business hours of the companies, are valid legally and binding on both the parties. This applies to the extent only in such cases where deadline time for transaction is not specifically declared by either or both the parties to the business.

C21 **LOI (Letter of Intent):**

BHEL may issue LOI prior to the PO for any reason whatsoever. The LOI in such cases is to be treated as PO for all practical purposes and all the Terms & Conditions of the tender shall be applicable from the date of issue of LOI.

C22 **General:**

a) BHEL will not be bound by any power of attorney granted by the vendors or by changes in the composition of the firm made subsequent to the execution of the contract. They may, however, recognize such power of attorney and changes after obtaining proper legal advice, the cost of which will be chargeable to the vendor concerned.



3BHEL  
GOINDWAL

TERMS AND CONDITIONS FOR  
(Tender Enquiry No. 1314-188 dated: 01.03.2014 Due date of opening 15.03.2014)  
Item: Ball Bearings

- b) BHEL reserves the right to accept or reject any part or whole of the tender by assigning a valid reason thereof. BHEL reserves the right to cancel the tender without assigning any reason thereof and without any obligation before any commitment.
- c) BHEL reserves the right to short close the contract at any time. The quantity supplied or requirement intimated by BHEL will stand as it is, but contract may be close for further supplies, if no further requirement exists.
- d) Please submit acceptance of all techno-commercial terms along with quotation. If nothing is mentioned for any term, it shall be concluded that the same is acceptable.
- e) Performance of suppliers shall be monitored periodically by user department of BHEL.

C23 **WORDS AND FIGURES**

- a. If, in the price structure quoted for the required goods/ services/ works, there is discrepancy between the unit price and the total price (which is obtained by multiplying the unit price by the quantity), the unit price shall prevail and the total price corrected accordingly, unless in the opinion of the purchaser there is an obvious misplacement of the decimal point in the unit price, in which case the total price as quoted shall govern and the unit price corrected accordingly.
- b. If there is an error in a total corresponding to the addition or subtraction of subtotals, the subtotals shall prevail and the total shall be corrected; and
- c. If there is a discrepancy between words and figures, the amount in words shall prevail, unless the amount expressed in words is related to an arithmetic error, in which case the amount in figures shall prevail subject of (a) and (b) above.
- d. If there is such discrepancy in an offer, the same shall be conveyed to the bidder with target date upto which the bidder has to send his acceptance on the above lines and if the bidder does not agree to the decision of the purchaser, the bid is liable to be ignored.

C24. **GENERAL TERMS AND CONDITIONS OF RA**

"BHEL reserves the right to go for Reverse Auction (RA) instead of opening the sealed envelope price bid, submitted by the bidder. This will be decided after techno-commercial evaluation. All bidders will give their acceptance for participation in RA. Non-acceptance to participate in RA may result in non-consideration of their bids, in case BHEL decides to go for RA.

In case BHEL decides to go for Reverse Auction, only those bidders who have given their acceptance to participate in RA will be allowed to participate in the Reverse Auction. Those bidders who have given their acceptance to participate in Reverse Auction will have to necessarily submit "online sealed bid" in the Reverse Auction. Non- submission of „online sealed bid" by the bidder will be considered as tampering of the tender process and will invite action by BHEL as per extant guidelines in vogue."

Terms & Conditions of Reverse Auction

Against this enquiry for the subject item/ system with detailed scope of supply as per enquiry specifications, BHEL may resort to "REVERSE AUCTION PROCEDURE" i.e., ON LINE BIDDING (THROUGH A SERVICE PROVIDER). The philosophy followed for reverse auction shall be English Reverse (No ties).

For the proposed reverse auction, technically and commercially acceptable bidders only shall be eligible to participate.

Those bidders who have given their acceptance for Reverse Auction (quoted against this tender enquiry) will have to necessarily submit "online sealed bid" in the Reverse Auction. Non-submission of „online sealed bid" by the bidder for any of the eligible items for which techno- commercially



3BHEL  
GOINDWAL

TERMS AND CONDITIONS FOR  
(Tender Enquiry No. 1314-188 dated: 01.03.2014 Due date of opening 15.03.2014)  
Item: Ball Bearings

qualified, will be considered as tampering of the tender process and will invite action by BHEL as per extant guidelines in vogue.

BHEL will engage the services of a service provider who will provide all necessary training and assistance before commencement of on line bidding on internet.

In case of reverse auction, BHEL will inform the bidders the details of Service Provider to enable them to contact & get trained.

Business rules like event date, time, bid decrement, extension etc. also will be communicated through service provider for compliance.

Bidders have to fax the Compliance form (annexure IV) before start of Reverse auction. Without this, the bidder will not be eligible to participate in the event.

In line with the NIT terms, BHEL will provide the calculation sheet (e.g., EXCEL sheet) which will help to arrive at "Total Cost to BHEL" like Packing & forwarding charges, Taxes and Duties, Freight charges, Insurance, Service Tax for Services and loading factors (for non-compliance to BHEL standard Commercial terms & conditions) for each of the bidder to enable them to fill-in the price and keep it ready for keying in during the Auction.

Reverse auction will be conducted on scheduled date & time.

At the end of Reverse Auction event, the lowest bidder value will be known on auction portal.

The lowest bidder has to fax/e-mail the duly signed and filled-in prescribed format for price breakup including that of line items, if required, (Annexure VII) as provided on case-to-case basis to Service provider within two working days of Auction without fail.

In case BHEL decides not to go for Reverse Auction procedure for this tender enquiry, the Price bids and price impacts, if any, already submitted and available with BHEL shall be opened as per BHEL's standard practice.

Bidders shall be required to read the "Terms and Conditions" section of the auctions site of Service provider, using the Login IDs and passwords given to them by the service provider before reverse auction event. Bidders should acquaint themselves of the "Business Rules of Reverse Auction", which will be communicated before the Reverse Auction.

If the Bidder or any of his representatives are found to be involved in Price manipulation/ cartel formation of any kind, directly or indirectly by communicating with other bidders, action as per extant BHEL guidelines, shall be initiated by BHEL and the results of the RA scrapped/ aborted.

The Bidder shall not divulge either his Bids or any other exclusive details of BHEL to any other party.

In case BHEL decides to go for reverse auction, the H1 bidder (whose quote is highest in online sealed bid) may not be allowed to participate in further RA process.

  
Authorized Signatory  
BHEL, IVP, Goindwal



3BHEL  
GOINDWAL

TERMS AND CONDITIONS FOR  
(Tender Enquiry No. 1314-188 dated: 01.03.2014 Due date of opening 15.03.2014)  
Item: Ball Bearings

**Annexure-I**

**Certificate by Chartered Accountant on letter head**

This is to Certify that M/S ....., (hereinafter referred to as 'company') having its registered office at ..... is registered under MSMED Act 2006, (Entrepreneur Memorandum No (Part-11) ..... dtd:....., Category: ..... (Micro/Small)). (Copy enclosed).

Further verified from the Books of Accounts that the investment of the company as on date..... as per MSMED Act 2006 is as follows:

1. **For Manufacturing Enterprises:** Investment in plant and machinery (i.e. original cost excluding land and building and the items specified by the Ministry of Small Scale Industries vide its notification No.S.O.1722(E) dated October 5, 2006:  
Rs.....Lacs
2. **For Service Enterprises:** Investment in equipment (original cost excluding land and building and furniture, fittings and other items not directly related to the service rendered or as may be notified under the MSMED Act, 2006:  
Rs.....Lacs

The above investment of Rs.....Lacs is within permissible limit of Rs.....Lacs for .....Micro / Small (Strike off which is not applicable) Category under MSMED Act 2006.

Date:

(Signature) Name-

Membership number-

Seal of Chartered Accountant

**BHARAT HEAVY ELECTRICALS LTD  
IVP, GOINDWAL SAHIB  
UNPRICE BID ANNEXURE**

**Annexure to Enquiry No. 1314-188 Dated 01.03.2014 Due Date of submitting quotations 15.03.2014**

**Item Ball Bearings**

S.No.	Matl Code	Desc	Drawing Number	Make/Specifications	Qty Nos.	Quoted Yes/No
1	551110620400	BALL BEARING 6204		SB:0002:Rev:07	2250	
2	551190620500	BALL BEARING 6205-2RS			2150	
3	552115110100	SINGLE THRUST BALL BEARING - 51101	3V040102888/01		2300	
4	552115110200	SINGLE THRUST BALL BEARING - 51102	3V045002888/01		2350	

Excise Duty rate (mention in % if applicable, mention as **NIL** if not applicable)

*Pl. clearly mention (Same as filled in unprice bid)*

Cess on ED rate (mention in % if applicable)

Extra@

*Pl. clearly mention (Same as filled in unprice bid)*

CST (%)

Extra@

*Pl. clearly mention (Same as filled in unprice bid)*

VAT (%)

Extra@

*Pl. clearly mention (Same as filled in unprice bid)*

Validity of offers (**As per BHEL terms 60 days validity is required**)

*Pl. clearly mention (Same as filled in unprice bid)*

Delivery terms (FOR Goindwal Sahib)

*Pl. clearly mention (Same as filled in unprice bid)*

MSE Firm (YES/NO)

*Pl. clearly mention (Same as filled in unprice bid)*

We accept all terms and conditions of the Tender Enquiry No.1314-188 Dated 01.03.2014

Please note that nothing will be considered other than prices in the price bid.

*Authorised signatory with seal*

**BHARAT HEAVY ELECTRICALS LTD****IVP, GOINDWAL SAHIB****PRICE BID ANNEXURE**

Annexure to Enquiry No. 1314-188 Dated 01.03.2014 Due Date of submitting quotations 15.03.2014

Item **Ball Bearings**

S.No.	Matl Code	Desc	Drawing Number	MAKE/ Specification	Qty Nos.	Unit price, Rs	
						In Figures	In Words
1	551110620400	BALL BEARING 6204		SB:0002:Rev:07	2250	Pls fill price bid	Pls fill price bid
2	551190620500	BALL BEARING 6205-2RS			2150	Pls fill price bid	Pls fill price bid
3	552115110200	SINGLE THRUST BALL BEARING - 51102	3V040102888/01		2300	Pls fill price bid	Pls fill price bid
4	552115110100	SINGLE THRUST BALL BEARING - 51101	3V045002888/01		2350	Pls fill price bid	Pls fill price bid

Validity of offers (As per BHEL terms 60 days validity is required)

*Pl. clearly mention (Same as filled in unprice bid)*

Delivery terms (FOR Goindwal Sahib)

*Pl. clearly mention (Same as filled in unprice bid)*

MSE Firm (YES/NO)

We accept all terms and conditions of the Tender Enquiry No.1314-188 Dated 01.03.2014

Please note that nothing will be considered other than prices in the price bid.

*Authorised signatory with seal*

ALL DIMENSIONS ARE IN MILLIMETRES. FOR TOLERANCES OF UNTOLERANCED DIMENSIONS DURING MANUFACTURE REFER RELEVANT QCP / QP.

88870-0000-A-3  
DRAWING NO.

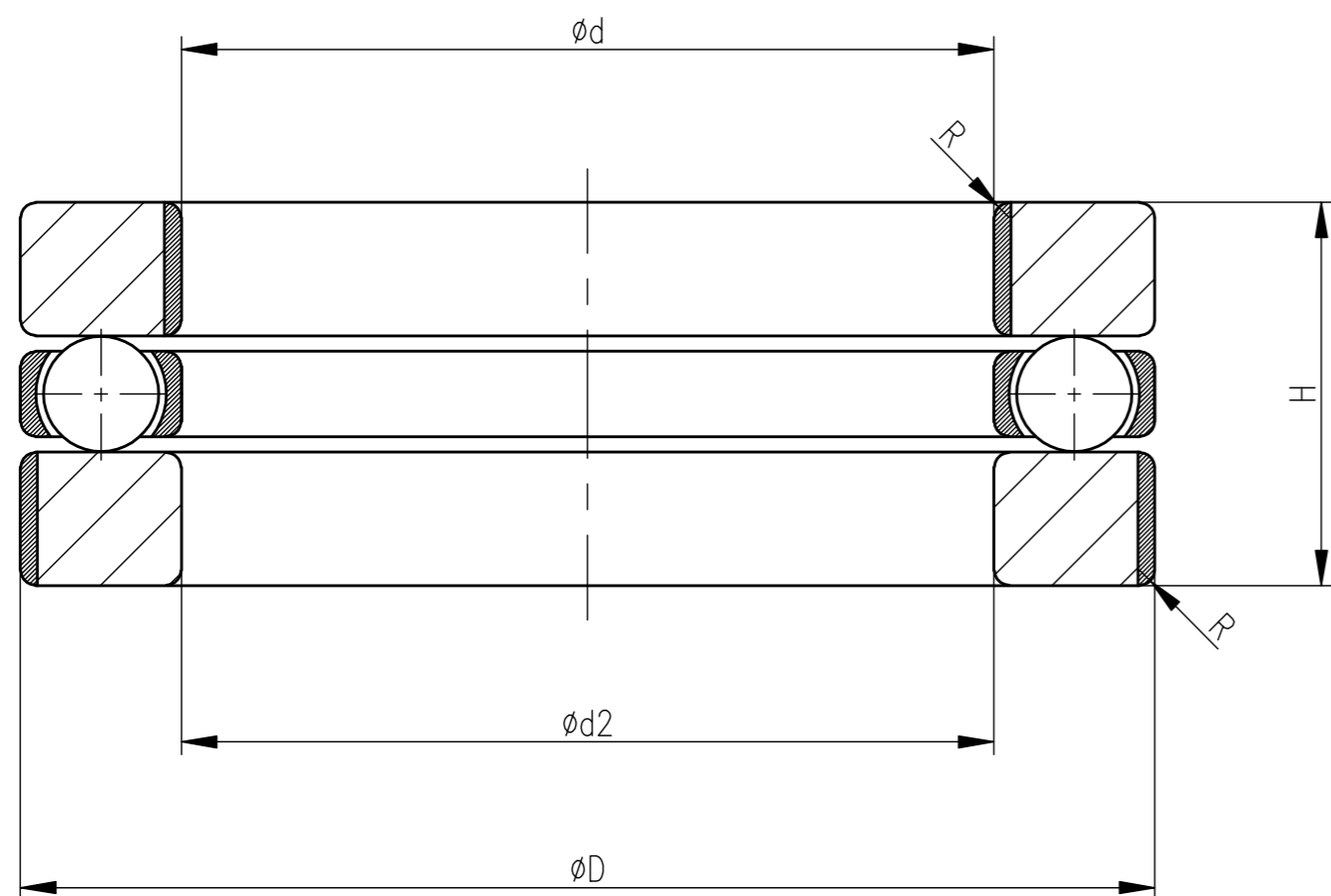

SL No.	DRAWING No.	BEARING No.	WT. in Kgs.	DIMENSIONS					STATIC BASIC CAPACITY-kgs.
				D	d	ød2-MIN	H	R	
01	3-V-0401-02888/01	51101	0.049	26 <sup>0</sup> <sub>-0.013</sub>	12 <sup>0</sup> <sub>-0.008</sub>	12.2	9	0.5	1250
02	3-V-0450-02888/01	51102	0.053	28 <sup>0</sup> <sub>-0.013</sub>	15 <sup>0</sup> <sub>-0.008</sub>	15.2	9	0.5	1370
03	3-V-0402-02888/01	51104	0.088	35 <sup>0</sup> <sub>-0.016</sub>	20 <sup>0</sup> <sub>-0.010</sub>	20.2	10	0.5	2200
04	3-V-0179-02888/01	51107	0.198	52 <sup>0</sup> <sub>-0.019</sub>	35 <sup>0</sup> <sub>-0.012</sub>	35.2	12	1	3900
05	3-V-2387-02888/01	51108	0.265	60 <sup>0</sup> <sub>-0.019</sub>	40 <sup>0</sup> <sub>-0.012</sub>	40.2	13	1	5200
06	3-V-1317-02888/01	51109	0.331	65 <sup>0</sup> <sub>-0.019</sub>	45 <sup>0</sup> <sub>-0.012</sub>	45.2	14	1	5700
07	3-V-0114-02888/01	51111	0.529	78 <sup>0</sup> <sub>-0.019</sub>	55 <sup>0</sup> <sub>-0.015</sub>	55.2	16	1	7650
08	3-V-0112-02888/01	51113	0.750	90 <sup>0</sup> <sub>-0.022</sub>	65 <sup>0</sup> <sub>-0.015</sub>	65.2	18	1.5	9650
09	3-V-0132-02888/01	51114	0.794	95 <sup>0</sup> <sub>-0.022</sub>	70 <sup>0</sup> <sub>-0.015</sub>	70.2	18	1.5	10400
10	3-V-0160-02888/01	51116	0.948	105 <sup>0</sup> <sub>-0.022</sub>	80 <sup>0</sup> <sub>-0.015</sub>	80.2	19	1.5	11600
11	3-V-0181-02888/01	51117	1.010	110 <sup>0</sup> <sub>-0.022</sub>	85 <sup>0</sup> <sub>-0.020</sub>	85.2	19	1.5	12500
12	3-V-1217-02888/01	51217	2.840	125 <sup>0</sup> <sub>-0.025</sub>	85 <sup>0</sup> <sub>-0.020</sub>	85.2	31	1.5	22000
13	3-V-1286-02888/01	51222	5.670	160 <sup>0</sup> <sub>-0.025</sub>	110 <sup>0</sup> <sub>-0.020</sub>	110.2	38	2	37500
14	3-V-1388-02888/01	51218	1.77	135 <sup>0</sup> <sub>-0.025</sub>	90 <sup>0</sup> <sub>-0.020</sub>	90.2	35	--	27000
15	3-V-1510-02888/01	51112	0.29	85 <sup>0</sup> <sub>-0.022</sub>	60 <sup>0</sup> <sub>-0.015</sub>	60.2	17	--	9300
16	3-V-1551-02888/01	51206	0.15	52 <sup>0</sup> <sub>-0.019</sub>	30 <sup>0</sup> <sub>-0.010</sub>	30.2	16	1	4800
17	3-V-9998-02888/01	51305	0.18	52 <sup>0</sup> <sub>-0.019</sub>	25 <sup>0</sup> <sub>-0.010</sub>	25.2	18	1	5100
18	3-V-1552-02888/01	51308	0.55	78 <sup>0</sup> <sub>-0.019</sub>	40 <sup>0</sup> <sub>-0.012</sub>	40.2	26	1.5	11200
19	3-V-9999-02888/01	51407	0.79	80 <sup>0</sup> <sub>-0.020</sub>	35 <sup>0</sup> <sub>-0.012</sub>	35.2	32	1.5	12700
20	3-V-1592-02888/01	51214	0.79	105 <sup>0</sup> <sub>-0.022</sub>	70 <sup>0</sup> <sub>-0.015</sub>	72	27	1.5	16300
21	3-V-L617-02888/00	51110	0.50	70 <sup>0</sup> <sub>-0.019</sub>	50 <sup>0</sup> <sub>-0.010</sub>	52	14	1	6200
22	3-V-L618-02888/00	51105	0.15	42 <sup>0</sup> <sub>-0.016</sub>	25 <sup>0</sup> <sub>-0.010</sub>	26	11	0.5	2900
23	3-V-L603-02888/00	51115	0.95	100 <sup>0</sup> <sub>-0.022</sub>	75 <sup>0</sup> <sub>-0.015</sub>	77	19	1.5	11200

REMARKS:

1. THE TOLERANCES GIVEN FOR øD & ød ARE APPLICABLE ONLY TO THE DIAMETERS INDICATED BY THE THICK LINES IN THE SKETCH.
2. PREFIX 55211 TO BEARING NOS. TO GET THE MATERIAL CODE.

REV	DATE	ALTERED	P.R.K
05	20.02.09	CHD & APPD	S.N.R

DCP:800814

SL.NO 21,22,23 ADDED.

SL No.	DESCRIPTION	MATL CODE	MATL SPECN	HEAT TREATMENT	SCRAP SORT	NET WT (kg)	GROSS WT (kg)	DRAWING No COMP. CODE	ITEM No	
-	-	-	-	-	-	-	-	-	-	
<p>CAUTION: The information on this document is the property of BHARAT HEAVY ELECTRICALS LTD. It must not be used directly or indirectly in any way detrimental to the interest of the company.</p>										
<p>TYPE OF PRODUCT OR NAME OF CUSTOMER/PROJECT</p>										
<p>BHARAT HEAVY ELECTRICALS LTD., UNIT: HIGH PRESSURE BOILER PLANT. TIRUCHIRAPALLI-620014.</p>				DRN	EC 005	SIGN	EC 005	DATE	18.11.82	NO.OF VAR.
				CHD	D. VIJAY	D. VIJAY		18.11.82		
				APPD	V. BABU	V. BABU		22.11.82		
DEPT	VL	SCALE	WEIGHT (KG).	REFERENCE INFORMATIONS				NO. OF ITEMS		
CODE	320	N T S	-							
TITLE						CARD CODE	DRAWING NO.		REV	
THRUST BALL BEARING						U 01	3-V-0000-02888		05	



365-148

**PRODUCT ENGINEERING / V&SB  
PURCHASE SPECIFICATION FOR  
BEARINGS USED IN  
SOOT BLOWERS**

**SPEC:SB:0002**  
Page 01 of 02

**REV:07**  
Dt.  
05/04/2013

1.0	COMPONENT	:	BEARING	
1.1	MATERIAL CODES	:	REFER BELOW	
<b>2.0</b>	<b>SPECIFICATION</b>	:	<b>BEARING No.</b>	<b>MATERIAL CODE</b>
2.1	BALL BEARING	:	SKF 6208 2RS (TWO SIDES RUBBER SEALED)	55 119 06208
2.2	BALL BEARING	:	SKF 6209 2RS (TWO SIDES RUBBER SEALED)	55 119 06209
2.3	BALL BEARING	:	SKF 6205 2RS (TWO SIDES RUBBER SEALED)	55 119 06205
2.3a	BALL BEARING	:	SKF 6205 RS	55 111 06205
2.4	BALL BEARING	:	SKF 6204	55 111 06204
2.5	BALL BEARING	:	SKF 6004	55 111 06004
2.6	BALL BEARING	:	SKF 6208	55 111 06208
2.7	BALL BEARING	:	SKF 6019 WITH "C4" CLEARANCE	55 111 06019
2.8	BALL BEARING	:	SKF 6206 2RS (TWO SIDES RUBBER SEALED)	55 119 06206
2.9	BALL BEARING	:	SKF 6206	55 111 06206
2.10	CAM ROL BEARING	:	MC GILL CYR 1 3/8S / IKO CRY22 VUU	97 353 31300
2.11	CAM FOLLOWER	:	MC GILL CF 1S IKO CR 16UU	97 353 93400 96 353 93400
2.12	THRUST BEARING	:	SKF 51101	55 211 51101
2.13	THRUST BEARING	:	SKF 51102	55 211 51102
2.14	THRUST BEARING	:	SKF 52206	55 211 52206
2.15	BALL BEARING	:	SKF 6309	55 111 06309
2.16	BALL BEARING	:	SKF 6202	55 111 06202
2.17	BALL BEARING	:	SKF 6021 WITH C4 CLEARANCE	55 111 06021
2.18	BALL BEARING	:	SKF 6020 WITH C4 CLEARANCE	55 111 06020
2.19	BALL BEARING	:	SKF 6305	55 111 06305
2.20	BALL BEARING	:	SKF 6005-2RS (TWO SIDES RUBBER SEALED)	55 119 06005
2.21	BALL BEARING	:	SKF 6210-2RS (TWO SIDES RUBBER SEALED)	55 119 06210
2.22	BALL BEARING	:	NDC 88505 LRI 301 KJF (SILICON GREASE LUBRICATED)	97 353 30500
			6305 ZZ- (SILICON GREASE LUBRICATED)	96 353 30500
2.23	GUIDE ROLL BEARING	:	IKO - NA 6908 UU MC GILL GR 32SS MI - 26	96 366 12400 97 366 12400
2.24	BALL BEARING	:	SKF 6008	55 111 06008
2.25	BALL BEARING	:	SKF 6017	55 111 06017

PREPARED BY  
(J SANKAR)

CHECKED BY  
(SHIVAM KUMAR GUPTA)

APPROVED BY  
(K.SRIDHARAN)



365-148

**PRODUCT ENGINEERING / V&SB  
PURCHASE SPECIFICATION FOR  
BEARINGS USED IN  
SOOT BLOWERS**

**SPEC:SB:0002**  
Page 02 of 02

**REV:07**  
Dt.  
05/04/2013

- 2.26 NEEDLE ROLLER BEARING : SCE 129P 97 366 18500
- 2.27 BALL BEARING : 6308-2RS (TWO SIDES RUBBER SEALED) 96 353 63100
- 3.0 Special Remarks :  
In addition to the bearing makes indicated against each part codes, bearing shall be procured only from reputed bearing manufacturer or their authorized stockists. Reputed make like SKF / FAG / NACHI / NTN / NSK / RHP / HMT bearings limited only to be procured from stockists.
- 4.0 PACKINGS :  
Bearings shall be packed in grease packed condition and in oil lubricated paper to avoid rusting before assembly bearings are to be packed in weather proof boxes (wooden) to with stand the transit hazards.
- 5.0 STORAGE :  
To be stored under covered area and the bearings are to be greased and packed if opened.
- 6.0 CRITICAL CHECK POINTS :  
1. Check for dimensions as per the catalogues.  
2. Check for damage.  
3. Check for radial clearance for the bearings with "C4" clearance.
- 7.0 Documents Required for Acceptance :  
Guarantee certificate 12/18 months has to be provided for trouble free operation.

Revision Number	Details
00	Initial Release
01	Note 3 Modified.
02	Converted as soft copy Dt. 11/04/2005
03	Sl. No. 2.8 - 5511906206 was 5511106206 Sl. No. 2.10 - INA RF 22PP & 96 353 313 0000 Removed Dt. 14/01/2006
04	Sl. No. 3.0 HMT bearings limited included. Dt. 24/04/2009.
05	Sl. No. 2.3a Added Dt. 24/04/2009.
06	Sl. No. 2.27 Added Dt. 26/03/2012.
07	Revision Details updated on 05/04/2013.

**REV 06 : 96 353 63100 CODE ADDED ON Dt. 26.03.2012**

PREPARED BY  
(J SANKAR)

CHECKED BY  
(SHIVAM KUMAR GUPTA)

APPROVED BY  
(K.SRIDHARAN)