



BHEL  
GOINDWAL

TERMS AND CONDITIONS FOR

Item: Name Plates

(Tender Enquiry no. 1314-111 dated 14.10.2013, due date of opening is 04.11.2013)

C1 **Inviting Quotations:**

Sealed Bid submission in two part Part-I: Techno-commercial bid and Part-II: Price bid are hereby invited for manufacturing and supply of Name Plates as per BHEL Drawings, Matl Standards (as per latest revision applicable), TDCs and other technical documents referred in these documents. The relevant documents are attached with the Enquiry.

The two bids should be submitted in **separate sealed inner envelopes** duly mentioning the detail as follows:

Bid	Description	Superscription on envelope	Min documents to be submitted
Part-I	Techno-Commercial bid in response to tender enquiry no. 1314-111 Dated 14.10.2013	PART-I: "Techno-Commercial Bid" Tender Enquiry no. 1314-111 Dated 14.10.2013 Due date of opening: 04.11.2013 Sender :	1. Acceptance of all terms and conditions. 2. Un-priced (Prices not filled) format showing taxes and duties structure.
Part-II	Price bid in response to tender enquiry no. 1314-111 Dated 14.10.2013	PART-II: "Price Bid" Tender Enquiry no. 1314-111 Dated 14.10.2013 Sender:	Price bid duly filled prices in words also along with same taxes and duties as mentioned in unpriced bid.

All the sealed envelopes should be put in an outer envelope clearly mentioning Tender Enquiry No. 1314-111 Dated 14.10.2013, item description as "Name Plates" and due date of opening as 04.11.2013 time 1530 hrs on it.

**Part-I: Techno-Commercial bid should contain**

- Acceptance of Techno-Commercial terms and conditions should be attached next. This can be attached either by signing each page of terms and conditions or a confirmation statement. If nothing is mentioned for any term, it shall be summarily concluded that the same is acceptable and no representation whatsoever shall be entertained later on.
- Un-priced bid as per format attached. All details, i.e. whether quoted for item, duties and taxes etc. should be filled.** Price Bid format without the price shall be provided with Part I.
- Any deviation proposed by bidder shall be considered by BHEL at its own discretion; and if finally considered, shall carry loading factor at the discretion of BHEL.

Quotations shall reach us by 1500 Hrs and Part-I shall be opened at 1530 Hrs on due date. Late offers are liable to be rejected, so please ensure to send the quotation well within due date. Based on evaluation of techno-commercial offers, Price bids of bidders who qualify from techno-commercial evaluation shall be opened. BHEL may decide to open the Price bid same day at 1630 hrs, if all the vendors have accepted the entire tender terms and conditions. If not opened on the same day, all qualifying bidders shall be notified for date of opening of Price bids.

**Part II: Price Bids:**

**Price bid in the format attached.** Preferably the price bid envelop should contain ONLY the price bid. Further, if even the same conditions are mentioned in the Part-II, but after scrutiny of Part-I, the bidder has agreed to BHEL terms, the same shall be binding and any such condition found in Part-II shall in no case be discussed.

**No Other format shall be used for submitting the price bid.** Any variation in Unit of Supply other than that mentioned in the Price bid format shall not be accepted.



BHEL  
GOINDWAL

TERMS AND CONDITIONS FOR

Item: Name Plates

(Tender Enquiry no. 1314-111 dated 14.10.2013, due date of opening is 04.11.2013)

Anything other than price mentioned in the price bid shall be considered invalid. If there is some discrepancy in Price Bid rates than the rates quoted in words shall be accepted.

Duties shall be payable extra against ED Gate Pass valid for CENVAT benefit.

Price quoted shall be firm and not subject to any escalation during the contract execution.

Price should be quoted on FOR Destination Goindwal Sahib basis. If not mentioned, it shall be concluded that the offer is on FOR Destination Goindwal Sahib basis. In case rates are Ex-Works basis, loading of expenses i.e., freight, transit insurance shall be done by BHEL at its discretion to arrive at Landed prices. Comparison shall be done at Landed cost to BHEL.

All amounts shall be indicated both in words as well as figures. Where there is difference between amount quoted in words and figures, amount quoted in words shall prevail.

Tenders should be free from CORRECTION AND ERASURES. Corrections if any must be attached. Sealed Tenders can be dropped in the tender box labeled as 'Tender box for MM contracts'. This tender box is located at the entrance of Admin block BHEL Goindwal. Tender may be handed over to Sh Gurbax Singh/ Head MM or Sh Pranshu in case of bulky tenders.

For any clarification you can contact on email id [tendermm@bhelivp.in](mailto:tendermm@bhelivp.in).

C2 **Validity of offers:**

Offers shall be valid for 60 days from due date of opening. In case of extension of due date of opening, the offers validity shall be extended accordingly.

C3 **Scope of supply:**

Material shall be supplied as per the applicable latest Technical Delivery Conditions (TDC)/ Material Standard requirements/BPS/Drawing and other requirement as given in the Purchase Order. **Where ever Trichy/Tiruchy/Tiruchirapalli is written in BPS/Drawing, it may be changed as Goindwal and this will be informed at the time of PO placement.** National & International material Standards shall have to be arranged by vendors themselves. For supply of Name Plates +/- 10% quantity may vary.

C4 **Replacement of Rejection:**

If the material is rejected due to defective workmanship during inspection or at the time of actual use, the rejected material shall be replaced by the supplier. Corresponding quantity shall be treated as unsupplied against respective purchase order till replacement is received at BHEL. If the material is found defective and rejected during use for which payment has already been released the rejected quantity shall be supplied free of cost by the vendor within a month of intimation of the rejection by BHEL.

C5 **Terms of payment:**

C5.1 Due payment against supplies received shall be made within 30-45 days of receipt subject to submission of test certificates (and other documents) and verification of user department and receipt of following dispatch documents.

In case of any deviation from standard payment term mentioned, BHEL at it's discretion may load on the item price at prime lending rate of SBI + 2% for the period of relaxation sought by bidder.

C3.5.1 Commercial invoice (in duplicate).

C3.5.2 Original VAT invoice valid for claiming input tax credit.

C3.5.3 Compliance Certificate & Inspection clearance certificate released at the time of Pre-Despatch inspection at vendor's works, if any.

C5.2 Above documents should include your Registration numbers such as ECC no, PAN no, CST no, TIN/ VAT nos. etc.



BHEL  
GOINDWAL

TERMS AND CONDITIONS FOR

**Item: Name Plates**

**(Tender Enquiry no. 1314-111 dated 14.10.2013, due date of opening is 04.11.2013)**

C5.3 BHEL will not be responsible for delays in release of payment on account of discrepancies in documentation, so vendor has to ensure compliance to documentation requirement

**C5.4 BHEL releases payment through EFT mode. Vendor can provide the necessary details by obtaining format before release of payment while supplying the material**

**C6 Delivery schedule:**

Supplies shall be affected and completed as per schedule mentioned in the POs. Supply shall to be completed **within Two months period from placement of PO/LOI. Further, BHEL may release delivery schedule from time to time based upon our requirement.** Vendor shall be required to complete the order as per the BHEL schedule requested.

**C7 Access to Manufacturing Premises:**

For evaluation & during the period of execution of contract, authorized representatives of BHEL shall be allowed free access to the manufacturing facilities for the purpose of inspection or monitoring the progress of contract. This access will also be extended to representatives of BHEL's customers accompanying the authorized representative/s of BHEL, if our contractual requirements with our customers call for the same.

**C8 Inspection:**

- a. All required tests shall be carried out by vendor at no extra cost. Relevant TCs shall accompany the consignment. BHEL may decide to inspect itself/arrange third party at vendors' works itself as and when necessary with prior intimation to the vendor. No additional charges shall be claimed for such inspections.
- b. Vendor will give inspection call sufficiently in advance considering the delivery period stipulated in the purchase order.
- c. Material Test Certificates (MTC), Inspection reports and Compliance/Guarantee Certificate are to be provided along with the supplies.
- d. Latest applicable revisions of standards/procedures to be referred.
- e. Any inspection carried out before supply by vendor/incoming stage at BHEL not withstanding, if any defect/non-conformity is noted during processing, the same shall be attended/replaced by vendor at no extra cost.

**C9 Guarantee:**

Vendor shall give a guarantee of 18 months from the date of dispatch or 12 months from the date of receipt, against manufacturing defects, whichever is earlier.

**C10 Risk Purchase**

BHEL shall be entitled to terminate the contract with any vendor and to purchase elsewhere at the risk and cost of the vendor, either the whole or part thereof which the supplier has failed to deliver within the time stipulated as aforesaid. Vendor shall be liable for the losses, which BHEL may sustain by way of such risk purchase in addition to aforesaid penalty for delayed delivery. Purchases made from any other vendor at its quoted rates shall be made and the difference of rates of defaulter vendor and new vendor shall be deducted from running bills of the vendor who has failed to deliver.

**C11 Penalty for late delivery**

'Time is the essence of the contract'. As such, delivery of goods specified in the Purchase Orders shall be made within the time limit prescribed therein. Penalty for late delivery clause will be applicable for delayed supplies @ 0.5% per week or part thereof subject to a maximum of 10%. **Once the delivery period mentioned has expired, and BHEL may or may not take the delivery of item.**

**C12 Sub-Contract:**



BHEL  
GOINDWAL

TERMS AND CONDITIONS FOR

**Item: Name Plates**

(Tender Enquiry no. 1314-111 dated 14.10.2013, due date of opening is 04.11.2013)

The purchase order or any part thereof shall not be sub-contracted, assigned or otherwise transferred without previously obtaining the BHEL's consent in writing

**C13 MSME & MSE Certification:**

If the bidder is registered as any of Micro/Small/Medium enterprise as defined in Micro Small and Medium Enterprises Development Act, 2006; a copy of registration certificate to be attached. MSE's shall be given preferences as described in "Public Procurement Policy for Micro and Small Enterprises (MSEs) Order, 2012" subject to the submission of proper documentary evidence (i.e. District Industries Centers or Khadi and Village Industries Commission or Khadi and Village Industries Board or Coir Board or National Small Industries Corporation or Directorate of Handicrafts and Handloom or any other body specified by Ministry of Micro, Small and Medium Enterprises) with quotation. "Public Procurement Policy for Micro and Small Enterprises (MSEs) Order, 2012" document can be downloaded from link <http://dcmsme.gov.in/FinalPressorder.pdf> and can also be collected from the office of Manager/MM IVP Goindwal.

**C14 Preferences for MSE's:**

Preferences as mentioned in "Public Procurement Policy for Micro and Small Enterprises (MSEs) Order, 2012" shall be given to Micro and Small enterprises.

Main points which are mentioned in the above order are as follows:

- 20% Procurement of the tender value shall be made from MSE (Micro, Small Enterprises) firms.
- 4% from the above mentioned 20% procurement quantity shall be procured from MSE's owned by SC /ST's. Failure to participate by any MSE owned by SC/ST's this 4% quantity shall be procured from other MSEs.
- All these benefits are subject to submission of all statutory documents.
- In tender, participating Micro and Small Enterprises quoting price within price band of L1+15 per cent shall also be allowed to supply a portion of requirement by bringing down their price to L1 price in a situation where L1 price is from someone other than a Micro and Small Enterprise and such Micro and Small Enterprise shall be allowed to supply up to 20 per cent of total tendered value. In case of more than one such Micro and Small Enterprise, the supply shall be shared proportionately (to tendered quantity).

**\*All these preferences are applicable subject to the submission of applicable certificates (i.e. District Industries Centers or Khadi and Village Industries Commission or Khadi and Village Industries Board or Coir Board or National Small Industries Corporation or Directorate of Handicrafts and Handloom or any other body specified by Ministry of Micro, Small and Medium Enterprises).**

**"MSE suppliers can avail the intended benefits only if they submit along with offer, attested copies of either EM II certificate having deemed validity (Two years from the date of issue of acknowledgement in EM-II) or valid NSIC certificate or EM II certificate along with CA certificate (Format enclosed as per Annexure - I) applicable for the year, certifying quantum of investment in plant and machinery within the permissible limit as per the act for relevant status (Micro or small) where the deemed validity of EM II is over. Date to be reckoned for determining the deemed validity will be the last date of technical bid submission. Non submission of such documents will lead to consideration of their bids at par with other bidders and MSE status of such suppliers shall be shifted to Non MSE supplier till the supplier submits these documents".**

**C15 Counter Offers**

BHEL reserves the right to negotiate or re-float the tender in case the quoted prices are not acceptable. If more than two vendors get qualified in the techno-commercial part (Part-1) of the



BHEL  
GOINDWAL

TERMS AND CONDITIONS FOR

**Item: Name Plates**

**(Tender Enquiry no. 1314-111 dated 14.10.2013, due date of opening is 04.11.2013)**

tender, then only BHEL will give counter-offer to the vendors except highest bidder, in order to have broader vendors base for ensuring timely delivery.

**C16 Loading**

BHEL reserves the right to negotiate with L1 or re-float the tender in case the quoted prices are not acceptable. BHEL will give counter-offer to vendors other than L1, in order to have broader vendors base for ensuring timely delivery. Following directions shall be followed when allotting the tender quantities:

1. Tender quantity shall be divided in the proportion 60:20:20 (60% for L1, 20% for L2 and 20% for MSE's) in case the L1 vendor is not a MSE subject to following conditions:
    - I. L2 acceptance of L1 rates.
    - II. In tender, participating Micro and Small Enterprises quoting price within price band of L1+15 per cent shall also be allowed to supply a portion of requirement at L1 price in a situation where L1 price is from someone other than a Micro and Small Enterprise and such Micro and Small Enterprise shall be allowed to supply up to 20 per cent of total tendered value. In case of more than one such Micro and Small Enterprise, the supply shall be shared equally.
  - I. 20% from the 20% quantity (i.e. 4% of the tender quantity) offered to the MSE's shall be reserved for MSE's owned by SC/STs. In event of failure of such Micro and Small Enterprises to participate in tender process or meet tender requirements and L1 price, 4 per cent quantity for Micro and Small Enterprises owned by SC/ST entrepreneurs shall be met from other Micro and Small Enterprises.
  - II. In case any MSE vendor does not accept the counter offer, the above mentioned 20% quantity shall be offered to L2 subject to its acceptance to L1 price.
1. In case if the L1 vendor is MSE then quantity shall be provided as 56 % and 40% in L1 and L2 vendor respectively subject to acceptance to above mentioned provision no.(I). 4% tender quantity shall be offered to the MSEs owned by SC/ST's in the price band of L1+15%. In event of failure of such Micro and Small Enterprises to participate in tender process or meet tender requirements and L1 price, 4 per cent sub-target for procurement earmarked for Micro and Small Enterprises owned by SC/ST entrepreneurs shall be met from L1 vendor.
  3. In case the L1 vendor is a MSE owned by a SC/ST then the quantity shall be divided as 60% and 40% to L1 and L2 vendor respectively subject to acceptance of L1 rates by L2 vendor.

In case of non- acceptance of counter offer by any vendor after above applicable provisions the whole quantity would be offered to L1 vendor.

This ratio can be altered in case of any failure on part of L1 regarding delivery commitment/quality of material. All above mentioned preferences shall be given to MSEs and SC/STs only on the submission of documentary evidence.

**All these preferences are applicable subject to the submission of applicable certificates (i.e. District Industries Centers or Khadi and Village Industries Commission or Khadi and Village Industries Board or Coir Board or National Small Industries Corporation or Directorate of Handicrafts and Handloom or any other body specified by Ministry of Micro, Small and Medium Enterprises).**



BHEL  
GOINDWAL

TERMS AND CONDITIONS FOR

Item: Name Plates

(Tender Enquiry no. 1314-111 dated 14.10.2013, due date of opening is 04.11.2013)

C17 **Force Majeure:**

If at any time during the continuance of the contract, the performance in which or in any part by either party of any obligations under the contract are prevented or delayed by reason of any war, hostilities, acts of public enemy, civil commotion, sabotage, fires, explosions, epidemics, quarantine restrictions, or acts of God (hereinafter referred to "an events") then provided the notice of happening of any such event is given by either party to the other within 21 days of the occurrence thereof, neither party shall by reason of such event be entitled to terminate the contract nor shall either party have any claim for damages against the other in respect of such non-performance and delay in performance and delivery under the contract shall be resumed as soon as practicable after such event has come to an end or ceased to exist. If the performance in whole or part of any obligation under the contract is prevented or delayed by reason of any such event, claims of extension of time shall be granted for periods considered reasonable by BHEL subject to prior notification by the vendor to BHEL of the particulars of the event and supply to BHEL, if required, of any supporting evidence. Any waiver of time in respect of partial instalment shall not be deemed a waiver of time in respect of remaining deliveries.

C18 **Arbitration:**

In the event of any dispute and/or difference arising between the Vendor and BHEL as to interpretation and/or execution of the contract and/or the respective rights and liabilities of the parties, such disputes and/or differences shall be referred to the sole arbitrator nominated by BHEL. The provisions of the Indian Arbitration Act and the rules there under shall apply to such arbitration. The award passed by the arbitrator shall be final and conclusively binding on all the parties.

C19 **Jurisdiction:**

The court of the place from where the purchase order is issued shall alone have jurisdiction to decide any dispute arising out of or in connection with the purchase order.

C20 **Banned Firms**

The offers of the bidders who are on the banned list as also the offer of the bidders, who engage the services of the banned firms, shall be rejected. The list of banned firms is available on BHEL website [www.bhel.com](http://www.bhel.com).

C21 **Clarifications:**

The correspondence exchanged against the tender from both tenderer and BHEL through email are considered as valid document legally though it is not signed. It is treated as valid confirmations made on behalf of the respective company and very much comes under the legal ambit of the business transaction and hence it is binding on both the parties to the business. Any transaction pertaining to the tender from both the parties of business done round the clock irrespective of the office or business hours of the companies, are valid legally and binding on both the parties. This applies to the extent only in such cases where deadline time for transaction is not specifically declared by either or both the parties to the business.

C22 **LOI (Letter of Intent):**

BHEL may issue LOI prior to the PO for any reason whatsoever. The LOI in such cases is to be treated as PO for all practical purposes and all the Terms & Conditions of the tender shall be applicable from the date of issue of LOI.

C23 **Words and Figures**

- a. If, in the price structure quoted for the required goods/ services/ works, there is discrepancy between the unit price and the total price (which is obtained by multiplying the unit price by the quantity), the unit price shall prevail and the total price corrected accordingly, unless in the



BHEL  
GOINDWAL

TERMS AND CONDITIONS FOR

Item: Name Plates

(Tender Enquiry no. 1314-111 dated 14.10.2013, due date of opening is 04.11.2013)

opinion of the purchaser there is an obvious misplacement of the decimal point in the unit price, in which case the total price as quoted shall govern and the unit price corrected accordingly.

- b. If there is an error in a total corresponding to the addition or subtraction of subtotals, the subtotals shall prevail and the total shall be corrected; and
- c. If there is a discrepancy between words and figures, the amount in words shall prevail, unless the amount expressed in words is related to an arithmetic error, in which case the amount in figures shall prevail subject of (a) and (b) above.
- d. If there is such discrepancy in an offer, the same shall be conveyed to the bidder with target date upto which the bidder has to send his acceptance on the above lines and if the bidder does not agree to the decision of the purchaser, the bid is liable to be ignored.

C24 **General:**

- a) BHEL will not be bound by any power of attorney granted by the vendors or by changes in the composition of the firm made subsequent to the execution of the contract. They may, however, recognize such power of attorney and changes after obtaining proper legal advice, the cost of which will be chargeable to the vendor concerned.
- b) BHEL reserves the right to accept or reject any part or whole of the tender by assigning a valid reason thereof. BHEL reserves the right to cancel the tender without assigning any reason thereof and without any obligation before any commitment.
- c) **The tender quantity given in enquiry is tentative; the final quantity of any item can be decrease by any extent.**
- d) BHEL reserves the right to short close the contract at any time. The quantity supplied or requirement intimated by BHEL will stand as it is, but contract may be close for further supplies, if no further requirement exists.
- e) Please submit acceptance of all techno-commercial terms along with quotation. If nothing is mentioned for any term, it shall be concluded that the same is acceptable.
- f) Performance of suppliers shall be monitored periodically by user department of BHEL.

**Certificate by Chartered Accountant on letter head**

This is to Certify that M/S .....,  
(hereinafter referred to as 'company') having its registered office at  
..... is registered under MSMED Act 2006, (Entrepreneur  
Memorandum No (Part-11) ..... dtd:.....,  
Category:.....(Micro/Small)). (Copy enclosed).

Further verified from the Books of Accounts that the investment of the company as on  
date..... as per MSMED Act 2006 is as follows:

1. **For Manufacturing Enterprises:** Investment in plant and machinery (i.e. original cost excluding land and building and the items specified by the Ministry of Small Scale Industries vide its notification No.S.O.1722(E) dated October 5, 2006:  
Rs.....Lacs
2. **For Service Enterprises:** Investment in equipment (original cost excluding land and building and furniture, fittings and other items not directly related to the service rendered or as may be notified under the MSMED Act, 2006:  
Rs.....Lacs

The above investment of Rs.....Lacs is within permissible limit of  
Rs.....Lacs for .....Micro / Small (Strike off which is not applicable)  
Category under MSMED Act 2006.

Date:

(Signature)

Name-

Membership number-

Seal of Chartered Accountant

**BHARAT HEAVY ELECTRICALS LTD**  
**IVP, GOINDWAL SAHIB**  
**Unprice Bid**

Annexure -2 Enquiry No. 1314-111 Dated 14.10.2013, Due date 04.11.2013.

Material: Name Plates

S.No	Material Code	Description of material	Technical document no.	Quantity required (in no.)	Quoted	Unit Basic Price, Rs. perLTR
1	220736490000	RATG.PL.WB180X108 BPS 017204	BPS 17204	500	Yes/No	"To be filled by vendor"
2	220745540000	CIR NAME PL20-BPS 017538	BPS 17538	500	Yes/No	"To be filled by vendor"
3	220745580000	CIR NAME PL36-BPS 017538	BPS 17538	500	Yes/No	"To be filled by vendor"
4	220745640000	CIR NAME PL60-BPS 017538	BPS 17538	2500	Yes/No	"To be filled by vendor"
5	220746490000	NAME PL-1373	4V137304047/01 (Drg no.)	8000	Yes/No	"To be filled by vendor"
6	220747200000	CAUTION PL-MANUAL	BPS 017545	500	Yes/No	"To be filled by vendor"
7	964532990000	CIR NAME PL.(ST.STEEL)-G004	3VG00120825/01 (Drg no.)	200	Yes/No	"To be filled by vendor"
8	964533000000	CIR NAME PL.(ST.STEEL)-G001	3VG00420825/01 (Drg no.)	200	Yes/No	"To be filled by vendor"
9	964566660000	TAG PLATE-5732	4V573206934/01 (Drg no.)	20000	Yes/No	"To be filled by vendor"

Excise Duty rate (mention in % if applicable, mention as <b>NIL</b> if not applicable)	Applicable/Not applicable	
	Extra/Inclusive	
	% if applicable	Pl. clearly mention in % if applicable
Cess on ED rate (mention in % if applicable)		
CST (%) / VAT (%)	Extra/Inclusive	
	%	Pl. clearly mention in % if applicable
Your firm is MSE (Micro,Small) or not?	Yes/No	
If MSE, is it owned by SC/ST?	Yes/No	
Validity of offers ( <b>As per BHEL terms 60 days validity is required</b> )		Pl. clearly mention

The above prices are **Firm, without any price esclation; are Rs. per Piece; and are on FOR Goindwal Sahib basis.**

We accept all terms and conditions of the Tender Enquiry No. 1314-111 dated 14.10.2013

Authorised signatory with seal

**BHARAT HEAVY ELECTRICALS LTD**  
**IVP, GOINDWAL SAHIB**  
**PRICE BID**

Annexure -3 Enquiry No. 1314-111 Dated 14.10.2013, Due date 04.11.2013.

Material: Name Plates

S.No	Material Code	Description of material	Technical document no.	Quantity required (in no.)	Unit Basic Price, Rs. Per Piece
1	220736490000	RATG.PL.WB180X108 BPS 017204	BPS 17204	500	"To be filled by vendor"
2	220745540000	CIR NAME PL20-BPS 017538	BPS 17538	500	"To be filled by vendor"
3	220745580000	CIR NAME PL36-BPS 017538	BPS 17538	500	"To be filled by vendor"
4	220745640000	CIR NAME PL60-BPS 017538	BPS 17538	2500	"To be filled by vendor"
5	220746490000	NAME PL-1373	4V137304047/0 1 (Drg no.)	8000	"To be filled by vendor"
6	220747200000	CAUTION PL-MANUAL	BPS 017545	500	"To be filled by vendor"
7	964532990000	CIR NAME PL.(ST.STEEL)-G004	3VG00120825/0 1 (Drg no.)	200	"To be filled by vendor"
8	964533000000	CIR NAME PL.(ST.STEEL)-G001	3VG00420825/0 1 (Drg no.)	200	"To be filled by vendor"
9	964566660000	TAG PLATE-5732	4V573206934/0 1 (Drg no.)	20000	"To be filled by vendor"

The above prices are **Firm, without any price escalation; are Rs. per Piece; and are on FOR Goindwal Sahib basis.**

Authorised signatory with seal



# PLANT STANDARD

HPBP TIRUCHIRAPPALLI

BPS 017204

Rev. No. 03

PAGE 1 OF 4

## RATING PLATE-WALL DESLAGGER

### 0.0 SCOPE

This standard covers the requirements of Rating Plate for wall deslagger.

### 1.0 SPECIFICATION AND REFERENCE STANDARDS

Dimensions and preferred sizes	Fig.1 of this standard
Tolerance	Medium to IS: 2102
Material	CuSn37 HA, 1.6 mm thick acc. to IS 410
BHEL monogram	Acc. to corporate standard AA 040 1120
Lettering style	Acc. to corporate standard AA 042 1403
Finish	See clauses 2.0 to 2.5 of this standard
Technical delivery conditions	Acc. to corporate standard AA 085 1411

### 2.0 FINISH

2.1 All rating plates shall be manufactured by etching and shall meet the following technical and other requirements.

2.2 TOP PORTION: All letters of the name of the company and monogram with border shall be raised and bright nickel plated. The background shall be etched and finished black (stoving enamel).

2.3 MIDDLE PORTION:

2.3.1 The following details of this portion shall be raised and bright nickel plated.

COPYRIGHT AND CONFIDENTIAL

The information on this document is the property of BHARAT HEAVY ELECTRICALS LIMITED. It must not be used directly or indirectly in any way detrimental to the interest of the company.

Revisions

**Brought upto date**

Approved

STANDARDS SECTION  
CONTRACT ENGINEERING AND CO-ORDINATION  
HPBP, TIRUCHIRAPPALLI

Rev. No. 03

Amd. No.

Reaffirmed

Prepared

Issued

Dt of 1st Issue

Dt. 18.01.97

Dt.

Year

STANDARDS

STANDARDS

JAN. 1984



# PLANT STANDARD

HPBP TIRUCHIRAPPALLI

BPS 017204

Rev. No. 03

PAGE 2 OF 4

- All letters of the name of the equipment.
- All 'pads' on which the rating particulars shall appear.

2.3.2 The following details of this portion shall be etched and finished black (stoving enamel).

- All letters, numerals etc. of the rating details appearing on the pads.
- All the dividing lines separating the pads from each other.
- Remaining area in the background

2.4 BOTTOM PORTION: All letters shall be raised and bright nickel plated. Remaining area in the background shall be etched and finished black (stoving enamel).

2.5 Border around the rating plate and the two dividing lines shall be raised and bright nickel plated.

### 3.0 DESIGNATION

A rating plate of size 180 mm length and 108 mm width to this standard shall be designated as :

3.1 On drawings

- a) Description column : RATG PL-WB 180x108
- b) Drawing number column : BPS 017204
- c) Material spec. column : Brass
- d) Material code column : 22 073 649

3.2 Ordering description

For placing indents, issuing enquiries and on purchase orders, ordering description given below shall be followed.

Rating plate - wall deslagger to BPS 017204



# PLANT STANDARD

HPBP TIRUCHIRAPPALLI

BPS 017204

Rev. No. 03

PAGE 3 OF 4

## 4.0 ADDITIONAL INFORMATION

4.1 Copies of the following standards shall be enclosed along with purchase order.

a) BPS 017 204

b) AA 040 1120

c) AA 042 1403

d) AA 085 1411

4.2 Material code shall be painted at the back of each piece.

4.3 The figure shown is for illustration only and supplier has to submit drawings to actual size for approval before effecting bulk supplies.



# PLANT STANDARD

HPBP TIRUCHIRAPPALLI

BPS 017204

Rev. No. 03

PAGE 4 OF 4

FIG. 1

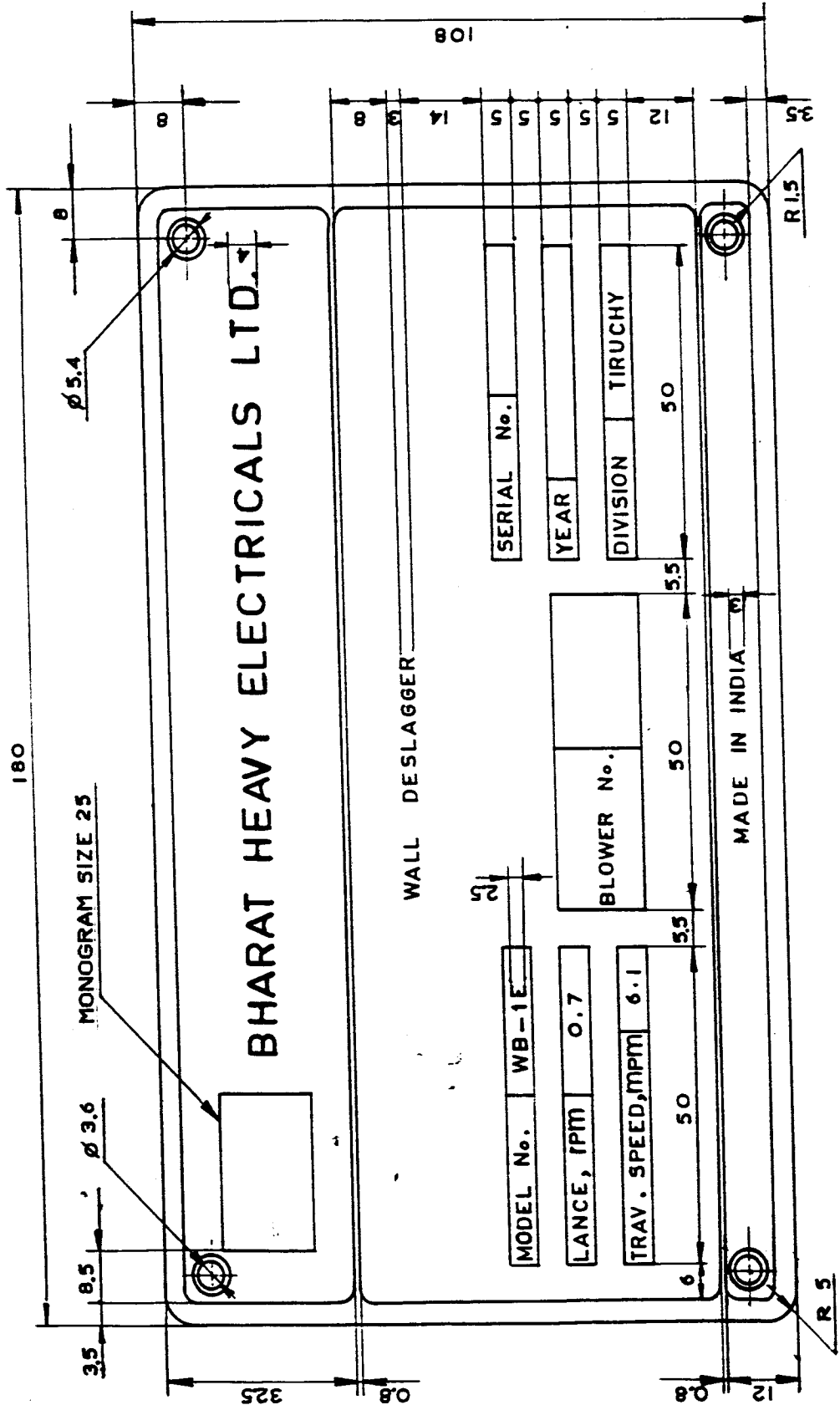



# PLANT STANDARD

HPBP TIRUCHIRAPPALLI

BPS 017538

64

Rev. No. 01

PAGE 1 OF 3

## CIRCULAR NAME PLATE FOR VALVES

### 0.0 SCOPE

This standard covers the requirements of Circular name plate for valves.

### 1.0 SPECIFICATION AND REFERENCE STANDARDS

Dimensions and preferred sizes	Fig.1 and table 1 of this standard
Tolerance	Medium to IS: 2102
Material	Aluminium sheet of thickness 1 mm
Lettering style	According to corporate standard AA 042 1403
Finish	See clause 2.1 of this standard
Technical delivery conditions	Acc. to clause 3.0 to 3.3.2 of this standard

### 2.0 FINISH

2.1 Name plates shall be hard anodized according to IS:6057 incorporating matter, letters and border in blue colour with white background.

### 3.0 TECHNICAL REQUIREMENTS

#### 3.1 GENERAL

3.1.1 The surface shall be free of cracks, blisters and damages. Sharp edges shall be rounded off.

3.1.2 Samples of the name plates shall be obtained and tested in the laboratory for durability of the material, anodizing and weather proofness before bulk supply is effected.

3.2 MARKING. Back side of each name plate shall be marked with material code given by BHEL and with manufacturer's identification.

Revisions			Approved			
Brought upto date			STANDARDS SECTION CONTRACT ENGINEERING AND CO-ORDINATION HPBP, TIRUCHIRAPPALLI			
Rev. No. 01	Amd. No.	Reaffirmed	Prepared	Issued	Dt of 1st Issue	
Dt. 18.01.97	Dt.	Year	STANDARDS	STANDARDS	MAR 1986	

COPYRIGHT AND CONFIDENTIAL  
The information on this document is the property of BHARAT HEAVY ELECTRICALS LIMITED. It must not be used directly or indirectly in any way detrimental to the interest of the company.



# PLANT STANDARD

HPBP TIRUCHIRAPPALLI

BPS 017538

65

Rev. No. 01

PAGE 2 OF 3

## 3.3 PACKING.

3.3.1 Before packing, each name plate shall be applied with transparent synthetic adhesive film.

3.3.2 Each name plate shall be suitably packed in polythene cover (500 microns thickness minimum) in order to avoid any damage to the surface during transit/storage etc.

## 4.0 DESIGNATION

A circular name plate for valve of size 24 to this standard shall be designated as :

### 4.1 On drawings

a) Description column : NPL CIR VALVE 24

b) Drawing number column : BPS 017538 0024

c) Material spec. column : Aluminium

d) Material code column : 22 074 555

### 4.2 Ordering description

For placing indents, issuing enquiries and on purchase orders, ordering description given below shall be followed.

Circular name plate for valves, size 24 to BPS 017538

## 5.0 ADDITIONAL INFORMATION

5.1 Copies of the following standards shall be enclosed along with purchase order.

a) BPS 017 538

b) AA 042 1403

5.2 The figure shown is for illustration only and supplier has to submit drawings to actual size for approval before effecting bulk supplies,



# PLANT STANDARD

HPBP TIRUCHIRAPPALLI

BPS 017538

66

Rev. No. 01

PAGE 3 OF 3

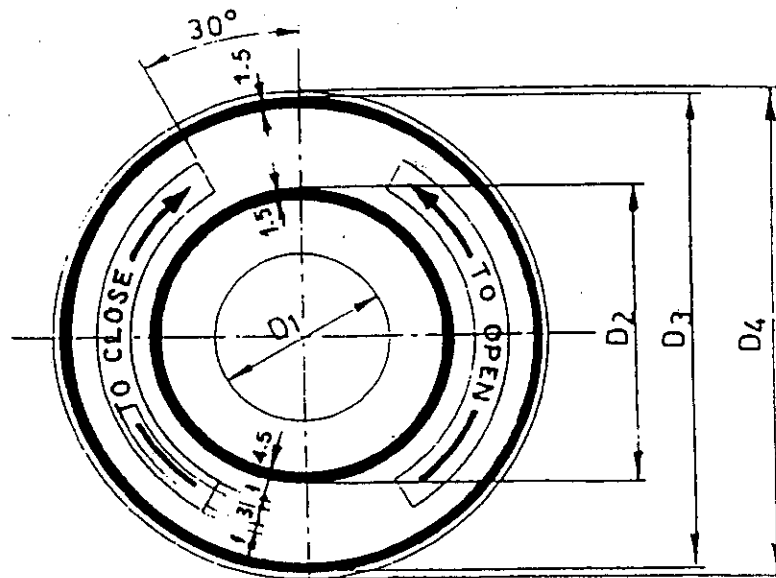

Figure 1

TABLE 1

(All dimensions in millimetres)

Nomi- nal size	D <sub>1</sub>	D <sub>2</sub>	D <sub>3</sub>	D <sub>4</sub>	Corresponding size of hand- wheel retain- ing nut	wt/1000 pieces in.kg
6	6.4	34	60	62	M6	7.47
8	8.4	34	60	62	M8	7.41
10	10.5	34	60	62	M10	7.33
12	13.0	34	60	62	M12	7.22
16	17.0	34	60	62	M16	6.98
20	21.0	39	65	67	M20	7.95
24	25.0	44	70	72	M24	3.95
27	28.0	49	75	77	M27	10.10
30	31.0	56	82	84	M30	11.97
36	37.0	61	87	89	M36	12.87
39	40.0	66	92	94	M39	14.21
42	43.0	71	97	99	M42	15.61
45	46.0	71	97	99	M45	15.09
52	54.0	81	107	109	M52	17.60
56	58.0	81	107	109	M56	16.72
60	62.0	106	132	134	M60	27.71
64	66.0	92	118	120	M64	19.72



ALL DIMENSIONS ARE IN MILLIMETRES.

FOR TOLERANCES OF UNTOLERANCED DIMENSIONS DURING MANUFACTURE REFER RELEVANT QCP/QP

REV 01	DATE 23.03.00	ALTERED K.P.LEON <i>John</i> CHD & APPD <i>Whe</i>
DIMENSION 80 WAS 75. DIMENSION 25 INTRODUCED. DIMENSION 35 WAS 30. TRIM SPACING INCREASED BY 5mm. REFER DCN:CS:1081		

SIZE OF LETTERS		~Wt./1000
ENAMELLED	PUNCHED	in kg.
2.0	1.5	4.43

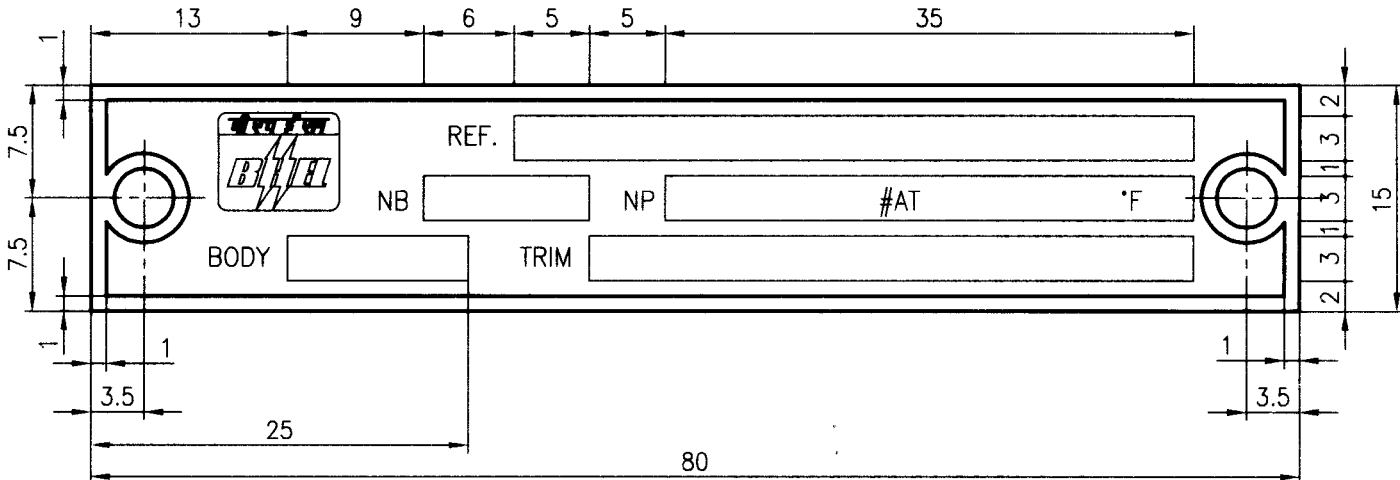

**NOTES:**

1. MATERIAL : 18/8 Cr.Ni. STEEL SHEET 0.5 mm THICK.
2. THE NAME PLATE SHALL HAVE RAISED BRIGHT POLISHED LETTERS. SPACES FOR DATA, EMBLEM AND BORDER ON ETCHED BLACK BACKGROUND.
3. THE MATERIAL OF WHICH THE BODY AND THE TRIM ARE MADE SHALL BE INDICATED BY CODES AS PER MSS-SP:25.
4. SCREW NAILS FOR FIXING NAME PLATES: SCREW NAILS SIZE 3 x 8 AS PER APPLICABLE STANDARDS.
5. THE NOMINAL BORE 'NB' WILL REPRESENT THE NOMINAL PIPE SIZE IN INCHES AND NOMINAL PRESSURE 'NP' WILL REPRESENT PRIMARY SERVICE PRESSURE IN (psig) AND CORRESPONDING SERVICE TEMPERATURE IN °F.
6. THE NAME PLATE SHALL BE CRACK-RESISTING SO THAT WHEN BENT THE ETCHING DOES NOT CRACK.
7. THE LOCATION OF THE NAME PLATE ON VALVES SHALL BE SPECIFIED BY THE DESIGNER.
8. AFTER FINALISING THE PURCHASE ORDER, SAMPLES OF THE NAME PLATE SHOULD BE TESTED IN THE LABORATORY FOR DURABILITY OF MATERIAL, ETCHING QUALITY ETC. BEFORE BULK SUPPLY IS EFFECTED.
9. THE EMBLEM SHALL BE BASED ON LATEST APPLICABLE STANDARDS.



-	-	-	-	-	-	-	-	-	-
NO OFF	DESCRIPTION	MATL CODE	MATL SPECN	HEAT TREATMENT	SCRAP SORT	NET WT (kg)	GROSS WT (kg)	DRAWING No	ITEM No



**BHARAT HEAVY ELECTRICALS LTD.**  
 UNIT: HIGH PRESSURE BOILER PLANT.  
 TIRUCHIRAPALLI 620014.

DRN	NAME K.P.LEON	SIGN <i>John</i>	DATE 23.03.2k	NO.OF VAR
CHD	T.R.R.MURTHY	<i>T.R.R.M</i>	23.03.2k	
APPD	K.S.RAMAN	<i>Whe</i>	23.03.2k	

DEPT VL	/	⊕	SCALE	WEIGHT (KG).	REFERENCE INFORMATIONS	NO. OF ITEMS
CODE 320			2:1	--	Component Code : 220746490000 CAD :C404047	

TITLE	CARD CODE	DRAWING NO.	REV
<b>NAME PLATE FOR VALVES (SS)</b>	U 01	<b>4-V-1373-04047</b>	<b>01</b>

CAUTION: The information on this document is the property of BHARAT HEAVY ELECTRICALS LTD. It must not be used directly or indirectly in any way detrimental to the interest of the company.



# PLANT STANDARD

HPBP TIRUCHIRAPPALLI

BPS 017545

Rev. No. 02

PAGE 01 OF 03

## CAUTION PLATE (FOR MANUAL OPERATION)

### 0.0 SCOPE

This standard covers the requirements of Caution Plate for manual operation.

### 1.0 SPECIFICATION AND REFERENCE STANDARDS

Dimensions and preferred sizes Fig.1 of this standard

Material CuSn37 HA, 0.5mm thick acc. to IS 410

Lettering style Acc. to corporate standard AA 042 1403

Finish See clause 2.1 to 2.2 of this standard

Technical delivery conditions Acc. to corporate standard AA 085 1411

### 2.0 FINISH

2.1 All caution plates shall be manufactured by etching and shall meet the technical delivery conditions.

2.2 All letters of the caution plate and border shall be raised and bright nickel plated. The back ground shall be etched and finished black (stoving enamel).

Revisions  
BROUGHT UPTO DATE

Approved  
STANDARDS SECTION  
CONTRACT ENGINEERING AND CO-ORDINATION  
HPBP, TIRUCHIRAPPALLI

Rev. No. 02

Amd. No.

Reaffirmed

Prepared

Issued

Dt of 1st Issue

Dt. 04.10.97

Dt.

Year

STANDARDS

STANDARDS

AUG 1984



# PLANT STANDARD

HPBP TIRUCHIRAPPALLI

BPS 017545

Rev. No. 02

PAGE 02 OF 03

## 3.0 DESIGNATION (typical case)

A caution plate of size 20 mm width and 80 mm length to this standard shall be designated as:

### 3.1 On drawings

- a) Description column : CAUTION PL MANUAL
- b) Drawing number column : BPS 017545
- c) Material spec. column : Brass
- d) Material code column : 22 074 720

### 3.2 Ordering description

For placing indents, issuing enquiries and on purchase orders, ordering description given below shall be followed.

Caution plate of size 20 x 80 to BPS: 017545

## 4.0 ADDITIONAL INFORMATION

### 4.1 Copies of the following standards shall be enclosed along with purchase order.

- a) BPS 017 545
- b) AA 042 1403
- c) AA 085 1411

### 4.2 Material code shall be painted at the back of each piece.

### 4.3 Supplier has to submit drawings to actual size for approval before effecting bulk supplies.

-----



ALL DIMENSIONS ARE IN MILLIMETRES. FOR TOLERANCES OF UNTOLERANCED DIMENSIONS DURING MANUFACTURE REFER RELEVANT QCP / QP.

3-V-000-20825/2  
DRAWING NO.

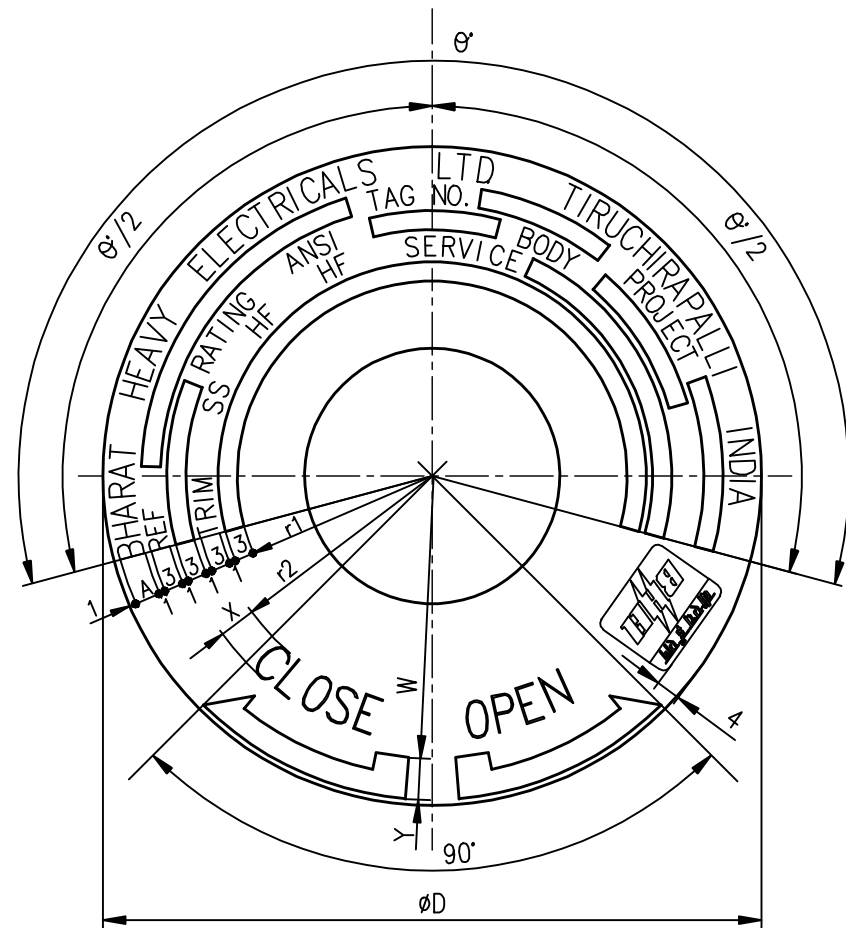

**NOTES:**

01. MATERIAL: 18-8 Cr. Ni STAINLESS STEEL.
02. THE NAME PLATE SHALL HAVE RAISED BRIGHT POLISHED LETTERS, EMBLEM ETC., ON ETCHED BLACK ENAMELLED BACKGROUND.
03. THE ENAMEL SHALL BE CRACK RESISTING SO THAT WHEN BENT THE ENAMEL DOES NOT CRACK.
04. MONOGRAM SHALL BE BASED ON CORPORATE STANDARD No. AA 040 11 20 REV.1
05. FINAL THICKNESS OF THE NAME PLATE AFTER ETCHING, ENAMELLING & POLISHING SHALL NOT BE LESS THAN 0.5mm. SUPPLIERS SHALL TAKE SUITABLE RAW MATERIAL THICKNESS TO MEET THE SPECIFIED FINAL THICKNESS.
06. THIN LINES SHOWN ARE FOR SPACING PURPOSE ONLY AND SHOULD NOT BE PRINTED.

REV	DATE	ALTERED	GANESH	REV	DATE	ALTERED	VB
2	08.08.11	CHD & APPD	GANESH&KRS	1	12.04.08	CHD & APPD	KRS&MRK
		MONOGRAM STANDARD HAS BEEN CHANGED FOR SL No.-10,11,12 & 13 DCP: 801209				DRAWING CONVERTED INTO SOFT COPY DCP No.800813	

SL. NO.	DRAWING NO.	COMP. CODE	DIMENSIONS								MONOGRAM STD.	
			$\phi D$	$\phi d$	r1	r2	$\theta^\circ$	A	W	X		Y
01	3-V-G004-20825/1	964532990000	80	23	20	27	200	3	34	6	5	15-AA 040 11 20
02	3-V-G001-20825/1	964533000000	80	27	20	27	200	3	34	6	5	15-AA 040 11 20
03	3-V-W005-20825/1	964533010000	125	52	41.5	42.5	165	4	53.5	10	7	15-AA 040 11 20
04	3-V-W002-20825/1	964532970000	160	62.5	59	60	128	4	71	10	7	25-AA 040 11 20
05	3-V-W006-20825/1	964533020000	160	72.5	59	60	128	4	71	10	7	25-AA 040 11 20
06	3-V-W113-20825/1	964533030000	160	82.5	59	60	128	4	71	10	7	25-AA 040 11 20
07	3-V-W003-20825/1	964533040000	200	86	79	80	102	4	91	10	7	40-AA 040 11 20
08	3-V-W117-20825/1	964533050000	200	96	79	80	102	4	91	10	7	40-AA 040 11 20
09	3-V-W004-20825/1	964533060000	200	102.5	79	80	102	4	91	10	7	40-AA 040 11 20
10	3-V-W345-20825/2	964532980000	120	50	39	40	172	4	51	10	7	15-AA 040 11 20
11	3-V-R009-20825/2	964533070000	125	58	41.5	42.5	165	4	53.5	10	7	15-AA 040 11 20
12	3-V-W065-20825/2	964533080000	145	70	51.5	52.5	143	4	63.5	10	7	25-AA 040 11 20
13	3-V-R033-20825/2	964533090000	170	90	64	65	122	4	76	10	7	25-AA 040 11 20

REDRAWN WITH REV.1 ON 12.04.08

NO OFF	DESCRIPTION	MATL CODE	MATL SPECN	HEAT TREATMENT	SCRAP SORT	NET WT (kg)	GROSS WT (kg)	DRAWING No	ITEM No
	TYPE OF PRODUCT OR NAME OF CUSTOMER/PROJECT <b>TA</b>								
	 <b>BHARAT HEAVY ELECTRICALS LTD.,</b> UNIT: HIGH PRESSURE BOILER PLANT. TIRUCHIRAPALLI-620014.				DRN	V.SIVALINGAM	SIGN	DATE	NO.OF VAR.
	365-121				CHD	K.RAJASEKARAN		12.04.08	
					APPD	M.RAJAKUMAR		12.04.08	
DEPT	VL	SCALE		WEIGHT (KG).		REFERENCE INFORMATION			NO. OF ITEMS
CODE	320	N.T.S							
TITLE						CARD CODE	DRAWING NO.		REV
<b>CIRCULAR NAME PLATE</b>						U 01	<b>3-V-0000-20825</b>		<b>2</b>

CAUTION: The information on this document is the property of BHARAT HEAVY ELECTRICALS LTD. It must not be used directly or indirectly in any way detrimental to the interest of the company.

FOR TOLERANCES OF UNTOLERANCED DIMENSIONS

ALL DIMENSIONS ARE IN MILLIMETRES.  
DURING MANUFACTURE REFER RELEVANT QCP/QP

REV	DATE	ALTERED VB
1	12.04.08	CHD & APPD KRS & M.R.K
DRAWING CONVERTED AS SOFT COPY		
DCP No.800813		

12.5/√

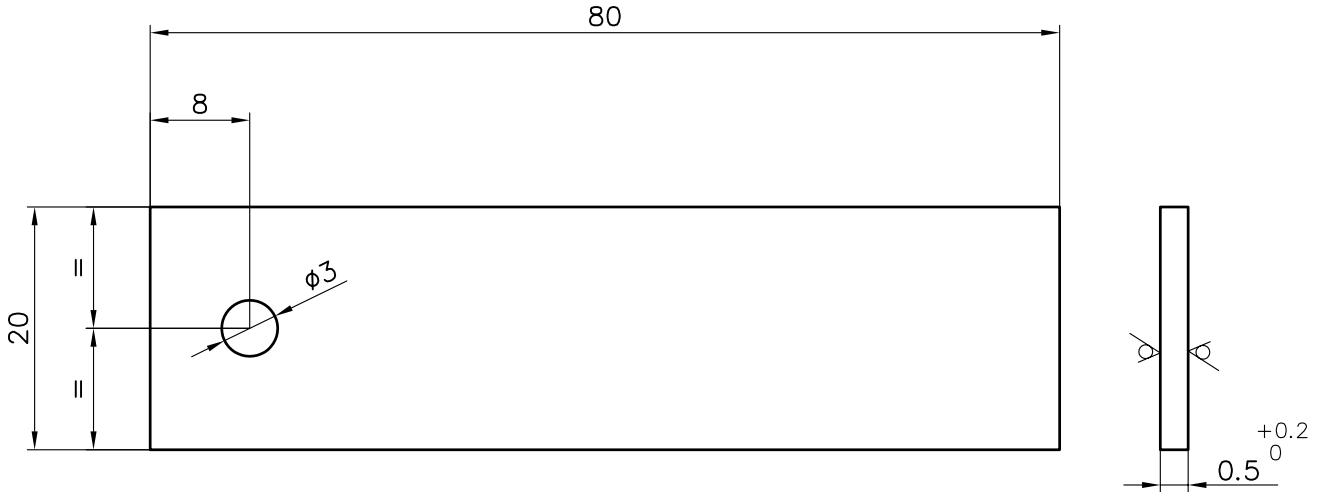

CAUTION: The information on this document is the property of BHARAT HEAVY ELECTRICALS LTD. It must not be used directly or indirectly in any way detrimental to the interest of the company.

NOTE:

1. Material: 18-8 Cr.Ni. steel.

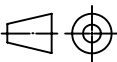
-	-	-	-	-	-	-	-	-	-
NO OFF	DESCRIPTION	MATL CODE	MATL SPECN	HEAT TREATMENT	SCRAP SORT	NET WT (kg)	GROSS WT (kg)	DRAWING No	ITEM No
 365-122	<b>BHARAT HEAVY ELECTRICALS LTD.,</b> UNIT: HIGH PRESSURE BOILER PLANT. TIRUCHIRAPALLI 620014.								
		DRN	R.MOHAN	SIGN	DATE	NO.OF VAR			
		CHD	K.S.RAMAN		15.03.96				
		APPD	N.NAGARAJAN		15.03.96				
DEPT VL	CODE	SCALE	WEIGHT (KG).	REFERENCE INFORMATION				NO. OF ITEMS	
320		NTS	0.01	Component Code : 964566660000 CAD : F406934					
TITLE					CARD CODE	DRAWING NO.		REV	
TAG PLATE					U 01	4-V-5732-06934		1	