



Electronics Division

PB No.2606, Mysore Road, Bangalore-560026, India
Tel 080 26998366 / email : suryaprakash@bheledn.co.in

Tender document for supply of : Test workstation

R F Q Number : TRSM900050

Tender Qty : **50 Numbers**

Tender Due Date and Time : 28.08.2009 13.00 Hrs

Tender Opening Date and Time : 28.08.2009 13.30 Hrs

Place of opening of Tender : SA – MM Conference hall

Scope: Supply, Installation and Commissioning of Test Workstation

1. Two part Bid - Tender shall be submitted in two parts :

- a. Part I – Techno commercial bid without prices.
- b. Part II – Price bid

Tender (quotation) shall be submitted in a sealed envelope super scribed with **RFQ NUMBER / and DUE DATE** on it. Tender to be dropped in the tender box placed in the Reception area at our works with caption “**Sub Assembly**”.

Tender shall be addressed to **Sr.DGM / EM – Coml & MM**, Electronics Division, Bharat Heavy Electricals Ltd., Mysore road, Bangalore 560026.

2. Delivery Required: 20 nos Within 12 weeks from date of Purchase Order.

30 nos Within 16 weeks from date of Purchase Order

3. Terms and conditions:

1. All the Bidders shall Comply with **Prequalification Criteria** and **Technical Specification** mentioned in this specific tender. Offers not complying with these are liable to be rejected.
2. Bidders are required to comply with the **General Terms and Conditions** as per **Annexure –I**
3. Drawings for the Test Workstation is as per **Annexure - II**

REF: 384/FR3/TWT/PQ – Rev 00

Page 01 / 01

Pre Qualification Criteria for SAT Test Workstations

Dt. 20/07/2009

1. The vendor shall be:
 - a) Based in India; or Foreign OEM with Authorized Indian dealer(s) / representative(s) for sales & service. The authorization letter for the dealer/ representative shall be provided if applicable.
 - b) Offer can be submitted by the OEM or their authorized dealers in India along with an authorization letter. However Purchase Order will be placed on the lowest technically acceptable bidder on the OEM only.
 - c) If the offer is from an authorized representative in India, the Indian representative cannot quote for the same equipment from more than one OEM.
2. The offer shall be only for new workstation and not for any refurbished / used workstation. All the parts used in the workstation shall also be new and not used / refurbished ones. A declaration to the above effect to be furnished
3. The vendor should have supplied a minimum 50 Nos. of ESD workstations in India in a single financial year during any of the last three financial years. Proof of the same has to be submitted. Details of the installations with customer name, contact details etc. to be furnished.
4. The vendor should have experience in supply of ESD products. Vendor should have at least a minimum of 3 ESD products in his product profile like ESD floor mats, ESD workstation, ESD tiles, ESD gloves etc.
5. The vendor shall be in a position to provide service and spares support for the installations.
6. The vendor should have a local representative in Bangalore to attend to service and spare request .Address of local representative to be provided.
7. The vendor shall arrange for a demonstration of a similar workstation, if required by BHEL.
8. The vendor shall furnish a comprehensive warranty at site for at least 12 months from the date of Installation or 18 months from the date of delivery, whichever is early.
9. The vendor shall guarantee the performance of the workstation for at least 12 months from the date of Installation.

NOTE:

1. Pre qualification will be carried out based on the details furnished by the vendor / feedback from their customers / inspection of the company / product if required by BHEL and at its sole discretion.
2. The Pre qualification criteria are mandatory requirements and the technical bids will be evaluated only when the Pre Qualification criteria are met.

REF: SAT-BKL-TWT-02 /Rev 00		Dt. 22-May-2008	
Specification for Test Workstation:			
	A. Scope: Supply and installation of Test work station as per the following specifications.		
	B. Technical Specifications: The offer shall be corresponding to the parameters under the specifications below or better. Point wise compliance to the following specification is required.		
	C. Supplier shall visit BHEL and study the existing Workstations, and discuss any issues for clarity, prior to submitting Quotation.		
SI No	Parameter / Requirement		
01	Basic Structure Requirement : (Refer: Drg. No. PCB_T-PRO - 0601B)		
	a)Overall dimension of table is approximately Length = 1800mm ,Width = 1080 mm ,Height =1560 mm.		
	b)Frame Material: Square Tube 40x40mm, 4mm thick: Steel(Powder coated MS of dark Brown / light grey color) /Aluminium		
	c)The table should have a common ESD grounding point. Electrical Panel & Wiring shall be as indicated.		
	d)There should not be any sharp edges		
	e) Leveling bush at the bottom of table for leveling		
	f)Handling : The design of frame should be such that it can be handled/lifted with a single fork lift / pallet truck(GND clearance 110mm+) and handling points to be marked.		
	g)The logo of ESD safe workstation should be put		
02A	Table Top: (Length*Width) 1800mm*1080mm		
	a) Material of Construction: Wood(>=25mm thk) with ESD Laminate		
	b) load capacity of approximately 250kg, & upto 40Kg/sq ft.		
02B	Storage rack on top of table: (Length*Width*Ht) 1800mm*450mm*180mm inner		
	a) Material of Construction: Wood(>=17mm thk) with ESD Laminate		
	b)height from Table top is approximately 555mm		
	c)load capacity of approximately 100kg, free of sag		
03	ESD Laminate: for Table Top, & Storage rack		
	a)ESD laminate should cover the entire table top, & Storage rack shelf, and terminated to the common ESD grounding point.		
	b)The edges also should be covered with laminate		
	c)edges of table, and shelf is preferably round arc		
	d)color of laminate is preferably light grey / ivory color		
	e)Laminate should be scratch proof		
	f)Surface resistivity of Table top, Storage rack shelf should be in the range 10^6 to 10^9 ohms / sq.		
	g)Sample of laminate to be supplied for approval		

04	Drawer unit: approx. 450W*650D*550H (mm): (3 drawers, equal height, with suitable handles)
	a) It should be modular. Material: Wood(>17mm thk, with outer lamination)
	b) It should have three sliding drawers with rail and bearings arrangement / channels for easy & smooth movement of drawer.
	c) All three drawers should have individual locks with a common key (three duplicate keys along with the main key to be provided)
05	PC Shelf: approx. 420W*650D*500H (mm), (inside height >=460mm, for PC)
	a) Material: Wood(>17mm thk, with outer lamination)
	b) 2 side + 1 rear Cable Mgr. Holes + 2" cutout at rear top for ventilation
	c) To house a PC. Also suitable to take load of 450V/15A - 3-PH Variac, with appropriate bottom frame support.
	d) Door with suitable handle, and Hinge on Left Hand Side
06	Keyboard Tray / Document Holder
	Size: 500x500mm, 20mm thk, above PC Shelf. Should project 25-30cm beyond Table Top, when fully drawn out
07	Side Covers: laminated Wood Board(>10mm thk): Full Length - recessed, in support frame.
08	Lamination of all Outer Surfaces: All Visible outer surfaces all sides / all units (storage rack, elec panel, drawer, pc shelf etc.) shall be covered with suitable laminate of same color as the ESD laminate.
09	Cable Manager Holes: Table Top(2), Storage Rack(4); PC Shelf(3); Electrical Panel(1)
10	Electrical Panel, Accessories:
	a) Base Material for Electric Panel: Pigmented Hylem Board, 4mm thick, gray color (Gray asbestos finish). 1800L x 555H(mm). Adequate support for sturdiness & firmness during operations. Suitable beading, if required.
	b) Back Door: Approx: 1800mm L x 555mm H x 15mm thk. Openable, hinged at bottom. With 2 tower bolts / Magnetic locks.
	c) Electrical Sockets/ Switches(S1..S9): 240V 6A/16A Multi pin Universal Socket with Piano Switch & Indicator: 9 Nos (3 on each phase)
	d) Electrical Components: All the Electrical components used should be of ISI mark
	e) Wiring: Wiring to be performed as per the Wiring Diagram provided. During wiring, for every 200mm a cable tie is to be provided.
	f) Cables: All cables used for wiring shall be preferably of M/S Finolex and Standard Color coding to be used. Cable to be used: 30/0.25 1.5mm sq., 15A multi strand, 1100V grade PVC insulated Copper,
	g) Power Input Cables/Plugs/Sockets: (1No. - 'SOC' - on front panel, one inside Electrical Panel.) Two Cutler Hammer Plugs, with 5 Core Cables of 5M, and 3M length to be provided. 5 Core Cable is of 25A/2.5sq.mm(multi strand). The sockets to be mounted on electrical panel as indicated.
	h) TBs (inside Electrical Panel): 8 Position TB to be provided for R,Y,B,N,E & 3 spare TBs.
	i) Circuit Breaker:(BRK1): 3 Ph Circuit Breaker of 440V/15A Rating to be provided.
	j) Circuit Breaker with ELCB:(BRK): Main 440V/15A 3PH CBK with ELCB
	k) Phase indicator lamps:(L1..L3): 240V w/ R, Y, B covers.
	l) Banana Sockets 4mm (C3 to C7): (R, Y, Blu, Black, G colors - / 3ph+N+E), for 3Ph Variac output
	m) Buttons for ESD Wrist Wrap: 4 Nos, at locations as shown.

11	Prototype for Evaluation & Pre shipment inspection
	<p>On order Placement, one prototype shall be made by the supplier, for inspection by BHEL at supplier works. Only after Acceptance of the Prototype, and clearance by BHEL, further production may be taken up.</p> <p>Tables should be supplied with complete wiring and with all the electrical fixtures to works. BHEL shall inspect the Test Stations at Supplier Works prior to dispatch clearance</p>
12	Warranty: The vendor shall furnish a comprehensive warranty for at least 12 months from the date of commissioning or 18 months from the date of delivery, whichever is early
	D. General conditions: <ol style="list-style-type: none">1. The offer shall be only for new equipment and not for any refurbished / used equipment.2. All the parts used in the equipment shall also be new and not used / refurbished ones. A declaration to the above effect to be furnished3. The vendor shall be in a position to provide service and spares support for the installations.4. The design of the workstation offered needs to be approved by BHEL during technical evaluation5. A clause wise deviation, if any, has to be brought out clearly. If there are no deviations, the vendor has to positively certify compliance to the specifications in toto.6. In case the vendor is not the OEM, current Authorization from the OEM along with support for servicing in the future years to be submitted.7. Specs for material/components used to be furnished.

Annexure -1**General Terms & Conditions for Supply, installation and commissioning of Capital Items for Sub Assembly (Two part bid)**

Bidders are required to read the general terms & conditions carefully and submit their quotation covering all the points. Any order resulting from this enquiry shall be governed by the general terms and conditions listed below.

Enquiry / Request For Quotation (RFQ):

- (a) Any Purchase Order resulting from this enquiry shall be governed by **these general terms and conditions listed below and special terms and conditions, if any, along with this enquiry** of Bharat Heavy Electricals Limited, Electronics Division, Bangalore-560026 (BHEL – EDN).
- (b) Any of the terms and conditions not acceptable to supplier, shall be explicitly mentioned in the quotation. Otherwise, it will be treated as that all terms and conditions of this enquiry are acceptable.
- (c) If counter terms and conditions are offered by supplier, BHEL EDN shall not be governed by such terms and conditions, unless it is agreed and incorporated in the Purchase Order of BHEL EDN.
- (d) Any deviation to the terms and conditions not mentioned in the quotation by supplier in response to this enquiry will not be considered, if put forth subsequently or after issue of order, unless clarification is sought for by BHEL EDN and agreed upon in the Purchase Order of BHEL EDN.
- (e) BHEL EDN reserves the right to adopt Reverse Auction for the enquiry sent at any point of time after technical evaluation, at its discretion. Bids with non acceptance of reverse auction will be liable for rejection. BHEL may also open the price bids at its discretion.
- (f) BHEL EDN shall be at liberty to cancel the tender at any time, before ordering, without assigning any reason.

1. **Quotation** : Quotation shall be submitted in two parts:

(a) Techno-commercial i.e., Un-priced Bid:

Techno-commercial bid shall be submitted with complete description of the equipment, specification compliances to the enquired specification and all the commercial terms & conditions indicated in the **QUOTATION FORMAT (ANNEXURE - A / ANNEXURE - B)**. Any other enclosure, which the supplier wishes to submit like product catalogue, technical literature etc., may also be submitted in this sealed envelope super scribed clearly as **“TECHNO-COMMERCIAL BID” with RFQ No. and DUE DATE**. **Un-priced** copy of price bid (without price) must be enclosed with this techno-commercial bid.

Confirmation to BHEL specifications shall be indicated by the vendor in the respective columns provided in the purchase specification wherever applicable. Deviations to the specification if

any shall be brought out clearly indicating “DEVIATION TO BHEL SPECIFICATION” without fail as a part of technical offer.

Compliance to Pre-qualification criteria shall also be enclosed with the Techno-commercial bid.

Manufacturer’s name, their trade mark and brand, part number, alternate material to the one asked in enquiry, if any, should be mentioned in quotation and illustrative leaflets giving technical particulars etc. are to be attached to facilitate consideration and technical evaluation of the quotation.

(b) Price Bid:

i. Foreign Purchase (FE Quote):

Price bid should contain basic unit price, total price, currency, including packing and any other charges on **FOB** basis in a sealed envelope super scribed clearly as “**PRICE BID**” with **RFQ No. and DUE DATE**. Installation, commissioning, start-up and training charges (if any) shall also be indicated in the price bid.

It is preferred to indicate the rates in both figures and words. In such case, if there is difference / discrepancy between the rates in figures and words, the **least of the two** will be considered.

ii. Indigenous Purchase (INR Quote):

Price bid should contain basic unit price, total price, on **FOR Destination** basis (delivery at BHEL – EDN indicating Duties, Taxes, packing, forwarding freight and insurance) in a sealed envelope super scribed clearly as “**PRICE BID**” with **RFQ No. and DUE DATE**. Installation, commissioning, start-up and training charges (if any) shall also be indicated in the price bid

It is preferred to indicate the rates in both figures and words. In such case, if there is difference / discrepancy between the rates in figures and words, the **least of the two** will be considered.

- 2. Bid Submission** Both these sealed envelopes [(a) Techno-commercial i.e., un-priced Bid and (b) Price Bids] shall be placed in a **separate sealed envelope** and super scribe clearly with **RFQ No. and DUE DATE**. The above sealed envelope (Tender) shall be dropped before the due date and time in the tender box marked “**Sub Assembly**” kept at BHEL-EDN’s Reception area of our works. This being capital equipment and two part bid, bids through FAX and email are not acceptable

BHEL EDN is not responsible for any delay in receipt of quotation sent by supplier through post / courier. Hence bidders to ensure / ascertain timely submission of offers well in advance.

Separate quotation should be submitted against each enquiry / RFQ.

Late Tenders i.e., Tenders received after due date and time will not be considered and stands rejected.

- 3.** The rate quoted against each item shall be in units stated in the enquiry. Where quotation is in terms of unit other than that in enquiry, relationship between the two units must be furnished in the quotation.

4. As far as possible, the quotations shall be free from corrections / overwriting. Corrections / overwriting, if any should be signed by authorized person with the company seal. Any typographical errors, totaling mistakes, currency mistakes, multiplication mistakes, summary mistakes observed in priced bids, BHEL may consider whichever is beneficial to BHEL for evaluation.
5. Quotations are to be duly signed. Unsigned bids / offers are liable for rejection.
6. Tenders / Techno commercial bids will be opened at **13:30 hrs.on the due date**, All the tenderers or their authorized representatives (with authorization letter from their principals) may witness opening of techno-commercial bid on the due date.
7. After evaluation of techno-commercial bids, price bids of only those which are technically & commercially accepted, will be opened on a subsequent date, which will be intimated to the concerned in advance for witnessing of price bid opening.

However BHEL EDN reserves the right to adopt Reverse Auction at any point of time.

8. The quantity in each item to be purchased may vary from quantity enquired according to the actual requirement at the time of placing the purchase order. Quantity discount, if any, should be mentioned in the quotation.
9. Withdrawal from the quotation after submission till order is placed will entail cancellation of the enquiry. Such supplier is liable for de-listing for future enquiries at the sole discretion of BHEL EDN.
10. Purchase Order will be placed on the lowest bidder (L1) only among the technically & commercially accepted quotations. Lowest quotation is determined on the basis of Total Cost to BHEL EDN including basic value, taxes and duties, freight, insurance, loading factors for deviations to terms and conditions
11. BIDDERS (for indigenous purchase) shall indicate clearly Excise duty, Education cess, Sales Tax/VAT, Octroi, Entry tax, Service Tax as applicable for the quoted items. In the absence of clarity of these, any claim at a later date will not be entertained. Any changes in Taxes and duties after award of the contract will not be considered except such of those, which are imposed by Govt. notification with documentary proof within the contractual delivery. Seeking price amendments for change in Excise duty due to crossing of turnover limits will not be considered.

12. D & B Report by foreign Vendors:

In case of foreign vendors, the vendors should obtain a report from **Dun & Bradstreet** or equivalent and submit a copy of the report with their Duns number mentioned along with the techno commercial bid.

13. Payment of Agency Commission to Indian Agent (for Foreign purchase):

In case OEM involves Indian agent for supply of the items / services, OEM / Indian agent shall furnish / confirm the following information along with the Techno Commercial bid:

- (a) Registration status of Indian Agent with DGS&D / BHEL / Any other Govt Agency.
- (b) Commission / general retainer fee payable to Indian Agent and percentage.
- (c) If agency commission is payable by the foreign principal / OEM, such commission shall be received by Indian agent through inward EFT remittance through banking channels and disbursed in rupees only.

- (d) Tax at source deduction is applicable to the agency commission paid to the Indian agent as per prevailing rules.
- (e) If the respective Indian Agents are not registered, they are required to register their names with BHEL by providing the following information for registration :
- (i) Name of the foreign firm / original equipment manufacturer represented by the Indian representative / Indian Agent.
 - (ii) Copy of Agency agreement.
 - (iii) PAN No, Name, Address of Bankers in India and Abroad.
 - (iv) Nature of services to be rendered by Indian Agent / Indian representative and percentage of commission payable to Indian Agent / Indian representative by Principal / original equipment manufacturer.
- (f) Undertaking to be submitted by Indian Representative / Agent that the agency commission would be accepted in Indian Rupees only and through EFT remittance through banking channel for the services rendered towards the execution of the orders.

14. PURCHASE ORDER : Placement of Purchase order will be considered on the lowest bidder (L1) only among the technically & commercially accepted quotations. Lowest quotation (L1) is determined on the basis of the **total cost to BHEL**. However BHEL does not bind itself to accept the lowest rate quoted, but reserves the right to accept whole or part of any quotation at it's sole discretion. No import license will be given by BHEL unless other wise stated specifically.

(a) FOR FOREIGN PURCHASE

Total cost to BHEL = Total basic value in foreign currency + FOB charges (if any) + Packing & Forwarding charges (if any) + Cost Insurance Freight (CIF) + Basic Custom Duty (BCD) + Counter Veiling Duty (CVD) + Educational Cess + Special Additional Duty (SAD) + Entry TAX + Service TAX (if applicable) + Loading factors for deviations to commercial terms & conditions.

Note: Exchange rate ruling on the date of Tender opening (Techno-commercial / un-priced Bid) will be considered for converting foreign currency to Indian currency. Exchange rates published in Economic Times (TT selling) will be considered.

(b) FOR INDIGENOUS PURCHASE

Total cost to BHEL = Total basic value + Packing & forwarding charges + Excise duty + Education cess + sales Tax/VAT + Octroi + Exit/Entry tax + Freight & Insurance + Service Tax (if applicable) + Loading factors for deviations to commercial terms & conditions.

15. FIRM PRICE: Rates quoted should be firm till the execution of the order including installation and commissioning.

16 . TERMS OF PAYMENT:

(a) FOR FOREIGN PURCHASE:

Payment will be made against "**SIGHT DRAFT**" on presentation of dispatch documents to our bankers .

The payment terms are as follows:

- (i) 90% against complete dispatch documents i.e. AWB / BOL, Invoice, Packing list, Warranty certificate, Certificate of country of origin etc., & balance 10 % on submission of Performance Bank Guarantee (PBG).
- (ii) If PBG is not agreeable vendors can also accept for the final 10% payment, payable after the warranty period + 6 months of claim period against supplementary invoice. In such cases loading for PBG is not applicable.
Payment through LC can be considered subject to loading factors as per **Clause 28.**

Bank charges are to respective accounts.

(b) FOR INDIGENOUS PURCHASE:

- (i) 90% basic payment + 100% taxes & duties with 30 days credit & balance 10% basic against submission of PBG.
- (ii) Payment through bank will attract loading factors as per clause 28.
- (iii) If PBG is not agreeable, vendors can also accept for the final 10% payment, payable after the warranty period + 6 months of claim period against supplementary invoice. In such cases loading for PBG is not applicable.
Bank charges are to respective accounts.

17. ADVANCE PAYMENT: Quotations with “Advance payment” or “Inland letter of credit” is liable for rejection.

18. PENALTY: Failure to deliver within the delivery time as per purchase order will attract unconditional **penalty of 0.5 % (half percent) per week or part thereof at the basic price of the goods for the undelivered quantity, subject to a maximum of 10%.**

FOR FOREIGN PURCHASE

Date of Airway bill / Date of Bill of Lading / Date of receipt by Freight Forwarder whichever is earlier shall be considered as delivery date for the purpose of penalty calculation.

FOR INDIGENOUS PURCHASE:

If pre-shipment inspection is involved, date of issue of pre-shipment call by the vendor along with test certificates / test reports / certificate of conformance / calibration reports as proof of completion will be treated as date of dispatch for the purpose of penalty calculation.

In the absence of reports stated above, actual date of inspection will be considered as date of dispatch for penalty calculation.

Date of receipt of equipment shall be considered as delivery date for the purpose of penalty calculation.

19. PBG: Performance Bank Guarantee (PBG) to be submitted on Rs.100/- non-judicial stamp paper as per the BHEL prescribed format given in **ANNEXURE - E / ANNEXURE - F** for 10% of the basic equipment value obtained from any BHEL member (consortium) banks indicated in **ANNEXURE-G.**

PBG shall be valid for entire warranty period plus 6 months claim period.

The Bank Guarantee shall be sent directly by the issuing Bank with their forwarding letter to the concerned Purchase Executive

20. A. WARRANTY : Equipment shall have warranty period of 18 months from the date of dispatch or 12 months from the date of commissioning whichever is earlier. Offers not complying to this is liable for rejection

20.B GUARANTEE: The vendor shall guarantee the performance of the equipment for at least 12 months from date of commissioning. Offers not complying to this is liable for rejection

21. TERMS OF DELIVERY:

(a) FOR IMPORTED PURCHASE:

Price offered shall be for goods packed and delivered **F.O.B.** (named international Airport / sea port) including packing, forwarding, Handling, Ancillary charges like processing of Sight Draft, Letter of credit (L/C) if applicable, negotiation of bank documents, Export declaration, Certificate of origin etc. Consignment shall be handed over to our authorized Freight Forwarder / Consolidator.

Packing shall be Road / Rail / Air / Sea worthy, best suitable for transshipment and to take care of transit damages.

Vendors shall indicate the name of International Airport / Seaport.

Note: Name of International Airport has to be selected from any one of the airports / sea ports indicated in the table provided in **ANNEXURE – C**.

(b) FOR INDIGENOUS PURCHASE:

Equipment shall be delivered on door delivery basis to BHEL EDN, Bangalore inclusive of packing, forwarding, freight and insurance charges. Offers not complying to this is liable for rejection.

Packing shall be Road / Air worthy, best suitable for transshipment and to take care of transit damages.

Vendors may dispatch the consignments through EDN/BHEL approved transporters indicated in **ANNEXURE - D** on Door Delivery basis.

Smaller consignments can be dispatched through Courier services / RPP with the prior approval of the purchasing Executive.

22. DELIVERY SCHEDULE: In the quotation, earliest firm delivery (number of weeks) by which material will be delivered from the date of order must be indicated. Quotations with delivery term such as 'ex-stock', 'subject to prior sale', or 'delivery at the earliest' are liable for rejection.

BHEL delivery requirement is indicate in page 1. For non compliance of delivery requirement loading factors will be applicable as per cl 28.

23. VALIDITY: Quotation should remain valid for a minimum period of **90 days** from the date of technical bid opening.

24. POST-ORDER REQUISITES:

- a) Pre-shipment inspection at vendor's works, if required, will be carried out by BHEL. Required assistance will have to be provided by the vendor at the time of pre-shipment inspection.
- b) Test certificates, Calibration certificates and warranty certificates as stipulated at the time of ordering shall be furnished.
- c) Items shall be dispatched by Air/Road/Rail/Sea worthy packing. Any damage and later rejection, due to poor / improper packing shall be to supplier's account. For air consignments packed in wooden material **Fumigation Certificate** shall be compulsorily forwarded along with invoice, packing list, etc to the freight forwarder.
- d) Any damage / rejection /shortage should be made good or replaced immediately without any extra cost to BHEL.
- e) Wherever commissioning is involved, it shall be carried out by the vendor's qualified engineers. Scope of work includes installation, commissioning and start-up trials till satisfactory performance level is reached as certified by BHEL. For installation and commissioning of equipments, personnel registered with ESI and PF authorities to be arranged by vendor

25. Any dispute arising out of this, shall be referred to the sole arbitration of Head of Dept. Materials Management of group concerned, BHEL EDN or any other officer nominated by him and his award shall be final and binding on the parties. The venue of the arbitration in all cases shall be Bangalore.

26. Any legal suit in respect of this enquiry lies in the court of Jurisdiction of Bangalore (India) only.

27. **RISK PURCHASE:** The purchaser at his discretion may also make purchase of the materials **NOT** supplied in time at the **RISK & COST** of the supplier. In this event, it will be obligatory on the part of the supplier who fails to supply the goods in time to make good to BHEL any loss due to such risk purchase.

28. LOADING FACTORS:

Loading factors as detailed below will be added to the quoted price (basic) to evaluate the lowest quote for non compliance of BHEL standard commercial terms.

A(i). For non compliance of standard Terms of payment (For Foreign Purchase Orders)

Sl. No.	BHEL standard term	If you quote	Loading factor in % for non-compliance
1	90% against "SIGHT DRAFT" + 10% against PBG	Payment through Letter of Credit (LC)	10 %

A(ii). For non compliance of standard Terms of payment (For Indigenous Purchase Orders)

Sl. No.	BHEL standard term	If you quote	Loading factor in % for non-compliance
1	90% basic payment + 100% taxes & duties with 30 days credit and balance 10% against submission of PBG	Payment through bank	10 %
		100% with 30 days credit & submission of PBG	Nil

B. For non compliance of Penalty clause:

Sl. No.	BHEL standard term	If you quote	Loading factor for non-compliance
1	Penalty of 0.5% per week or part thereof subject to max. of 10% on the basic value of the items not supplied /delayed	Not agreed.	10 %
		5% max., agreed.	5%
		Other than the above.	10% - (minus) agreed max. %

C. For non compliance of Performance Bank Guarantee (PBG):

Sl. No.	BHEL standard term	If you quote	Loading factor for non-compliance
1	PBG for 10% of the basic material cost shall be furnished in the BHEL prescribed format.	Not agreed.	10 %
		5% agreed.	5 %
		Other than the above.	10% - (minus) agreed max. %

D. For Non conformance to delivery requirement indicated in the RFQ:

Sl. No.	BHEL standard term	If you quote	Loading factor for non-compliance
1	Delivery requirement as indicated in the RFQ in number of weeks from the date of issue of PO	Not agreed for the stipulated delivery in the enquiry	0.5 % per week up to max. of 2 %.

Note : Our delivery requirement is within 12 weeks for I lot of 20 nos and 16 weeks for II lot of 30 nos from the date of order and hence delay in delivery beyond 4 weeks in each case is not acceptable.

29 Installation & Commissioning : For installation and commissioning of equipments, personnel registered with ESI and PF authorities to be arranged by vendor.



- 30 Limitation of liability** : Limitation of liability by the vendor is limited to the value of the order.
- 31. Weight and Dimension** : Weight and Dimension of the consignment with packing (gross weight) for delivery shall be mentioned in the offer.
- 32.** BHEL reserves the right to RE-FLOAT/REJECT/CANCEL this TENDER ENQUIRY (RFQ) without assigning any reason or cause thereof. Quotes received against this TENDER ENQUIRY are subject to and governed by all these terms and conditions. BHEL's decision will be final in awarding of the contract and binding on all vendors.
- 33. 33.** BHEL will not be responsible for any loss, damage or injuries to vendor's personnel sustained during installation / commissioning/start-up trials. Vendor shall ensure compliance with all statutory requisites as laid down by local bodies, state and central Government.

QUOTATION FORMATTECHNICAL BID (TO BE ENCLOSED WITH TECHNO-COMMERCIAL BID)(for Foreign Purchase Orders)

Sl. No.	Particulars	Bidder's confirmation
1	Price basis: Firm i.e., from the date of PO to completion of contract [Price Variation Clause (PVC) not acceptable]	Acceptable / Not acceptable
2	Terms of Payment: Against "SIGHT DRAFT" on presentation of documents to our bankers. (a) 90 % is payable on negotiation of complete set of original documents & balance 10% against submission of PBG (c) Deviation if any please specify Note: Refer clause 16	(a) Acceptable / Not acceptable
3	BHEL's penalty clause: (a) Delay in delivery as per PO delivery date will result in penalty of 0.5 % per week and part thereof subject to maximum of 10% on the value of the items not supplier/delayed. (b) Deviation if any Please specify Note: Refer clause 18	(a) Acceptable / Not acceptable (b)
4	Performance Bank guarantee: PBG for 10% of the basic material cost shall be furnished in the BHEL prescribed format as detailed in clause 19.	Yes / No
5	Warranty / Guarantee: (a) BHEL Requirement (b) Deviation if any Please specify Note: Refer clause 20.	(a)Acceptable / Not acceptable (b)
6	Terms of delivery: (a) F.O.B international Airport/Seaport. Indicate name of International Airport/Seaport (b) Deviation if any Please specify Note : Ref clause 21	(a)Acceptable / Not acceptable (b)
7	Delivery Quoted: Indicate number of weeks from the date of Purchase order Note : Refer CI 22	_____Weeks
8	Validity: (a) Quotation should remain valid for a period of 90 days from the due date (b) Deviation if any Please specify	(a) Acceptable / Not acceptable (b)
9	Bank charges (If applicable): (a) Bank charges within India is to BHEL account and outside India is to Supplier's account (b) Deviation if any Please specify	(a) Acceptable / Not acceptable (b)
10	Weight and Dimension of consignment with packing	To be enclosed

Signature of tenderer / with seal

ANNEXURE - B

TECHNICAL BID (TO BE ENCLOSED WITH TECHNO-COMMERCIAL BID)

(For Indigenous Purchase Orders)

Sl. No.	Particulars	Bidder's confirmation
1	Price basis: Firm i.e., from the date of PO to completion of contract [Price Variation Clause (PVC) not acceptable]	Acceptable / Not acceptable
2	Excise duty: If applicable indicate %.	Applicable / Not applicable ED: _____%
3	Sale tax: If applicable indicate %	Applicable / Not applicable (a) VAT _____% (b) CST _____% against form C
4	Payment terms: (a) 90 % basic payment + 100% taxes, duties, freight & insurance charges with 30 days credit & balance 10% against submission of PBG (where commissioning is NOT involved) (b) Deviation if any please specify Note: Note: Refer clause 16	(a) Acceptable / Not acceptable (b)
5	BHEL's penalty clause: (a) Delay in delivery as per PO delivery date will result in penalty of 0.5 % per week and part thereof subject to maximum of 10% on the value of the items not supplier/delayed. (b) Deviation if any Please specify Note: Refer clause 18	(a) Acceptable / Not acceptable (b)
6	Performance Bank guarantee (PBG): PBG for 10% of the basic material cost shall be furnished in the BHEL prescribed format.. Note: Refer clause 19	Yes / No
7	Warranty / Guarantee: (a) BHEL Requirement (b) Deviation if any Please specify Note: Refer clause 20.	(a)Acceptable / Not acceptable (b)
8	Terms of delivery: (a) FOR EDN / BHEL, Bangalore (Free delivery to EDN/BHEL Bangalore) (b) Deviation if any Please specify Note: Refer clause 21	(a)Acceptable / Not acceptable (b)
9	Delivery Quoted : Indicate number of weeks from the date of issue of Purchase order . Note Refer cl 22	_____Weeks
10	Validity: (a) Quotation should remain valid for a period of 90 days from the due date (b) Deviation if any Please specify	(a) Acceptable / Not acceptable (b)
11	Weight and Dimension of consignment with packing	To be enclosed.

Signature of tenderer / with stamp

ANNEXURE - C

A . LIST OF INTERNATIONAL AIRPORTS

Sl. No	Country	Air Ports
1	Austria	Vienna, Linz, Graz
2	Australia	Sydney, Melbourne, Perth
3	Belgium	Antwerp, Brussels
4	Canada	Toronto, Montreal
5	China	Shangai
6	Cyprus	Lamaca
7	Czech Republic	Prague (Via Frankfurt)
8	Denmark	Copenhagen
9	Egypt	Cairo
10	Finland	Helsinki
11	France	Paris (Rossy), Lyon
12	Germany	Darmstadt, Manihem, Nurnberg, Hamburg, Stuttgart, Munich, Koln, Dusseldorf & Hannover, Frankfurt, Berlin
13	Hongkong	Hongkong
14	Italy	Rome, Milan, Turin, Bologna, Florence
15	Ireland	Dublin
16	Isrel	Telaviv
17	Japan	Tokyo, Osaka
18	Malaysia	Kaulalampur, Penang
19	Neatherlands	Amsterdam, Rotterdam
20	Newzealand	Auckland
21	Norway	Oslo
22	Oman	Muscat
23	Philiphines	Manila
24	Romania	Bucharest
25	Russia	Moscow
26	Saudi Arabia	Riyad
27	Singapore	Singapore
28	Slovakia	Bartislowa
29	South Africa	Johannesburg, Durban
30	South korea	Kimpo
31	Spain	Barcelona
32	Sweden	Stockholm, Gothenburg, Milano
33	Switzerland	Basle, Zurich, Geneva
34	Taiwan	Taipei
35	U.A.E.	Dubai
36	U.K.	Landon (Heathrow), Newcastle, Oxford, Cheltham, Bristol, Wellingborough, Birmingham, East Midland, Manchester, Leeds, Glasgow.
37	U.S.A.	Newyork, Chicago, Sanfrancisco, Los Angeles, Atlanta
38	Ukraine	Kiev

B. INTERNATIONAL SEAPORTS			
SECTOR	LOAD PORT	SECTOR	LOAD PORT
<i>EUROPE / SCOTLAND / AFRICA SECTOR</i>	<i>Felixstowe</i>	<i>JAPAN / FAR EAST / CHINA / S.KOREA SECTORS</i>	<i>Kobe</i>
	<i>Le Harve</i>		<i>Yokohama</i>
	<i>Rotterdam</i>		<i>Nagoya</i>
	<i>Antwerp</i>		<i>Tokyo</i>
	<i>Hamburg</i>		<i>Osaka</i>
	<i>Genoa</i>		<i>PortKlang</i>
	<i>Gothenburg</i>		<i>Singapore</i>
	<i>Bilbao</i>		<i>Hongkong</i>
	<i>Bremen</i>		<i>Busan</i>
	<i>Algeciras</i>		<i>Masan</i>
	<i>Barcelona</i>		<i>Shanghai</i>
	<i>Cadiz</i>		<i>Yawata</i>
	<i>La Spezia</i>		<i>Quingdao</i>
	<i>Venice</i>		<i>Yantai</i>
	<i>St.Petersbug</i>		<i>Dalian</i>
<i>Thamesport</i>	<i>Tianjin</i>		
<i>Durban</i>			
<i>Dundee</i>			
<i>BLACK SEA & MED PORTS / RUSSIA / CZECH / POLAND / FINLAND / UKRAINE</i>	<i>Odessa</i>	<i>MIDDLE EAST SECTORS</i>	<i>Dubai / Rashid Port</i>
	<i>Ily Cheivsk</i>		<i>Jebel Ali</i>
	<i>Helsinki</i>		<i>Oman</i>
	<i>Gdinya</i>		



EDN/BHEL APPROVED TRANSPORTERS FOR INLAND ROAD TRANSPORTATION

1. M/s Awagaman Road Carriers Ltd., Bangalore. (AWG)
2. M/s Delhi Assam Roadways corporation Ltd., Bangalore. (DRL)
3. M/s Indo Arya Central transport ltd., Bangalore. (IACT)
4. M/s Prakash parcel Services, Bangalore. (PPS)
5. M/s Road Carrier of India, Bangalore. (RCI)
6. M/s Union Roadways Ltd., Bangalore. (URL)
7. Economic Transport Organisation Limited (ETO)
8. Precious Carrying Corporation Limited . (PCC)

ANNEXURE-EPERFORMANCE BANK GUARANTEE
(FOR FOREIGN PURCHASE ORDERS)BANK NAME AND ADDRESS

Bharat Heavy Electricals Limited (BHEL),
Electronics Division,
PB No. 2606,
Mysore Road,
BANGALORE- 560 026
INDIA

Dear Sir,

Ref: CONTRACT PERFORMANCE GUARANTEE.

WHEREAS you have entered into a contract reference No PO NO. _____ with M/s _____ having its registered office at _____ for the supply of _____ as detailed in your purchase order No. _____ which is hereinafter referred to as "the said contract" and WHEREAS M/s _____ has undertaken to produce a Bank Guarantee for 10% (Ten Percent) of _____ (_____) to secure its obligations to Electronics Division, BHEL having its registered office at New Delhi for the performance of the contract including the warranty of the equipment supplied, We _____ Bank, _____ hereby expressly, irrevocably and unreservedly undertake and guarantee as principal obligors on behalf of M/s _____ that in the event Bharat Heavy Electricals Ltd. (B.H.E.L.) declares to us in writing that M/s _____ has not fulfilled any obligation according to the contractual obligation of the said contract, to pay you on demand and without demur to Bharat Heavy Electricals Ltd., Electronics Division , Mysore Road, P.B.No. 2606, Bangalore-560 026, India an amount of _____ (in words _____) subject to as may be determined below:

- 1) Notwithstanding any right M/s. _____ may have directly against you or any disputes raised by M/s _____, Your written demand shall be conclusive evidence to us that repayment is due under the terms of the said contract and shall be binding on us.
- 2) We shall not be discharged or released from this undertaking and Guarantee by any arrangements, variations made between you and M/s. _____ with or without our consent and Knowledge or by any alterations in the obligations of M/s. _____ by any forbearance whether as to payment, time, performance or otherwise.
- 3) This guarantee shall remain valid until the end of twenty-four weeks after the close of the warranty period or until the same is reported by BHEL to us whichever is earlier.
- 4) We agree and undertake not to revoke this guarantee during its validity unless discharged in writing by you subject to the provision of clause (7) below.



- 5) This guarantee shall be a continuing guarantee subject to the foregoing and shall not be discharged by any change in the constitution of the Bank or M/s. _____.
- 6) This guarantee shall be governed by and constructed in accordance with the Laws of India.
- 7) At any time _____ Bank may render this guarantee null and void by paying to Bharat Heavy Electricals Ltd. the full amount being _____ (in _____ words _____)

For and on behalf of Bank
by its Authorised Signatory

Note:

- (1) To be executed in INR 100 Non-Judicial stamp paper by any authorized Indian Bank.
- (2) To be submitted directly by banker to concerned executive in purchase dept., Please give BHEL address to banker.
- (3) Do not enclose with Bank document.

ANNEXURE - F**PERFORMANCE BANK GUARANTEE
(FOR INDEGENOUS PURCHASE ORDERS)**

THIS DEED OF GUARANTEE made and executed on the _____ day of _____(year), by the _____ (Bank), registered under the Companies Act 1956/Nationalised Bank constituted under the Banking Companies (acquisition and transfer of undertakings) Act constituted under the State Bank of India Act / Subsidiary Banks Act, having its registered / head office at _____ represented herein by its Branch Manager / authorised representative Sri. _____ & Sri. _____(Hereinafter called 'guarantor ' which term shall mean and include its successors and assigns)

IN FAVOUR OF BHARAT HEAVY ELECTRICALS LIMITED

_____ (Buyer's Name), a company registered under the companies Act, 1956 having its registered office at BHEL House at Siri Fort , New Delhi-100 049 and its Electronics Division at Mysore road, Bangalore-26 (hereinafter referred to as the 'Company' Which term shall include its successors and assigns):

Whereas the company has placed an order on _____ (State the name of the company / firm and its address) (hereinafter referred to as the 'Supplier' which term shall mean and include its liquidators, successors and assign) for the supply of system under order / Contract No. _____ Dt _____.

AND WHEREAS the supplier has agreed to supply the materials and carryout the works as detailed and in accordance with the terms set out in the said order/contract.

AND WHEREAS the company is not required to pay to the supplier a sum of Rupees _____being the 10% of the value of the goods supplied / Works performed / Services rendered under the said order / contract between the supplier and the company, till the company is satisfied with the mechanical Warranties and the performance standards stipulated in the said order / contract between the company and the supplier has been duly fulfilled, except against a Bank Guarantee for the said sum of Rs _____ in favour of the company by reputed Bank, in which case the company has agreed to make payment to the supplier of the said sum of Rupees _____ being (...%) of the value of the goods supplied / Works performed / Services rendered under the agreement between the supplier and the company and the Guarantor has at the request of the supplier, agreed to furnish this Guarantee subject to the terms and conditions stated below:

NOW THIS DEED WITNESSES THAT IN pursuance of the above said agreement, the guarantor hereby agrees and covenants With company is as follows :-

- 1) That during the period this contract of Guarantee remains effectual, the guarantor shall be liable in respect of the amount due and owing to the company in respect of the payments to the extent of Rs _____ (in words) _____ against any loss or damage caused to or suffered by the company by reasons of any breach of the terms of the said order / contract / Agreement by the supplier.
- 2) The Guarantor hereby undertakes to pay the amounts due and payable under this guarantee without any demur, merely on demand from the company intimating that the amount claimed is due by way of loss or damage caused to or suffered or would be caused or suffered by the supplier of any terms contained in the said order / contract. Any such demand made on the

guarantor shall be conclusive as regards the amount due and payable by the Guarantor irrespective of the fact whether the Contractor / supplier admits or denies.

- 3) The Guarantor further agrees that the agreement herein contained shall remain in force and effect till all the supplies to be made / Works to be performed / Services to be rendered under the said order / contract / agreement are completed to the entire satisfaction of the company or till company certifies that the terms and conditions of the said order / contract / agreement have been fully and properly carried out by the said supplier and accordingly discharges the Guarantee. Unless a demand or claim under this guarantee is made on the guarantor in writing on or before the expiry of claim period indicated in clause 6 below , the guarantor shall be discharged from all the liability under this guarantee thereafter.
- 4) The guarantor further agrees with the company that the company shall have the fullest liberty without the consent of the guarantor and without effecting in any manner the obligations of the guarantor hereunder to vary any of the terms of the said order / contract / agreement or extend the time of performance by the said supplier from time to time or refrain from exercising the power exercisable by the company against the said supplier or to forebear or omit to enforce any of the terms and conditions relating to the said order / contract / agreement, and the guarantor shall not be relieved of its liability in whole or in part , by reason of any act, commission or forbearance on the part of the company or by reason of any such variation, or extension being granted to the said supplier or by reason of any such matter or thing whatsoever which under the law relating to sureties would but for this provision have effect of so relieving the guarantor.
- 5) The guarantor undertakes not to revoke this guarantee during its currency except with the previous consent of the company in writing.
- 6) Notwithstanding anything herein above contained, the liability of the guarantor under these presents is restricted to Rs_____. The guarantee shall be in force till its expiry on _____ unless a demand is made on the guarantor within SIX months from the date of expiry, all the liability of the guarantor under this guarantee shall stand fully discharged. The decision of the claimant in regard to breach of contract is final and binding on the Bank.

IN WITNESS whereof, the guarantor, acting through it authorised representative has executed this deed of Guarantee on the day, month and year first above written.

(Seal of the Bank to be affixed)

WITNESS

1.

2.

**ANNEXURE - G****BHEL MEMBER BANKS (CONSORTIUM BANKS)****PBG SHALL BE ISSUED FROM THE FOLLOWING BANKS ONLY**

State Bank of India	The Hongkong and Shanghai Banking Corporation Ltd
ABN AMRO Bank N.V.	ICICI Bank Ltd
Bank of Baroda	IDBI Ltd.
Canara Bank	Punjab National Bank
CITI Bank N.A.	Standard Chartered Bank
Corporation bank	State Bank of Travancore
Deutsche Bank AG	State Bank of Hyderabad
HDFC Bank Ltd.	Syndicate Bank
Indian Bank	Oriental Bank of Commerce
Kotak Mahindra Bank ltd	Central bank of India
UCO bank	The Federal bank Limited

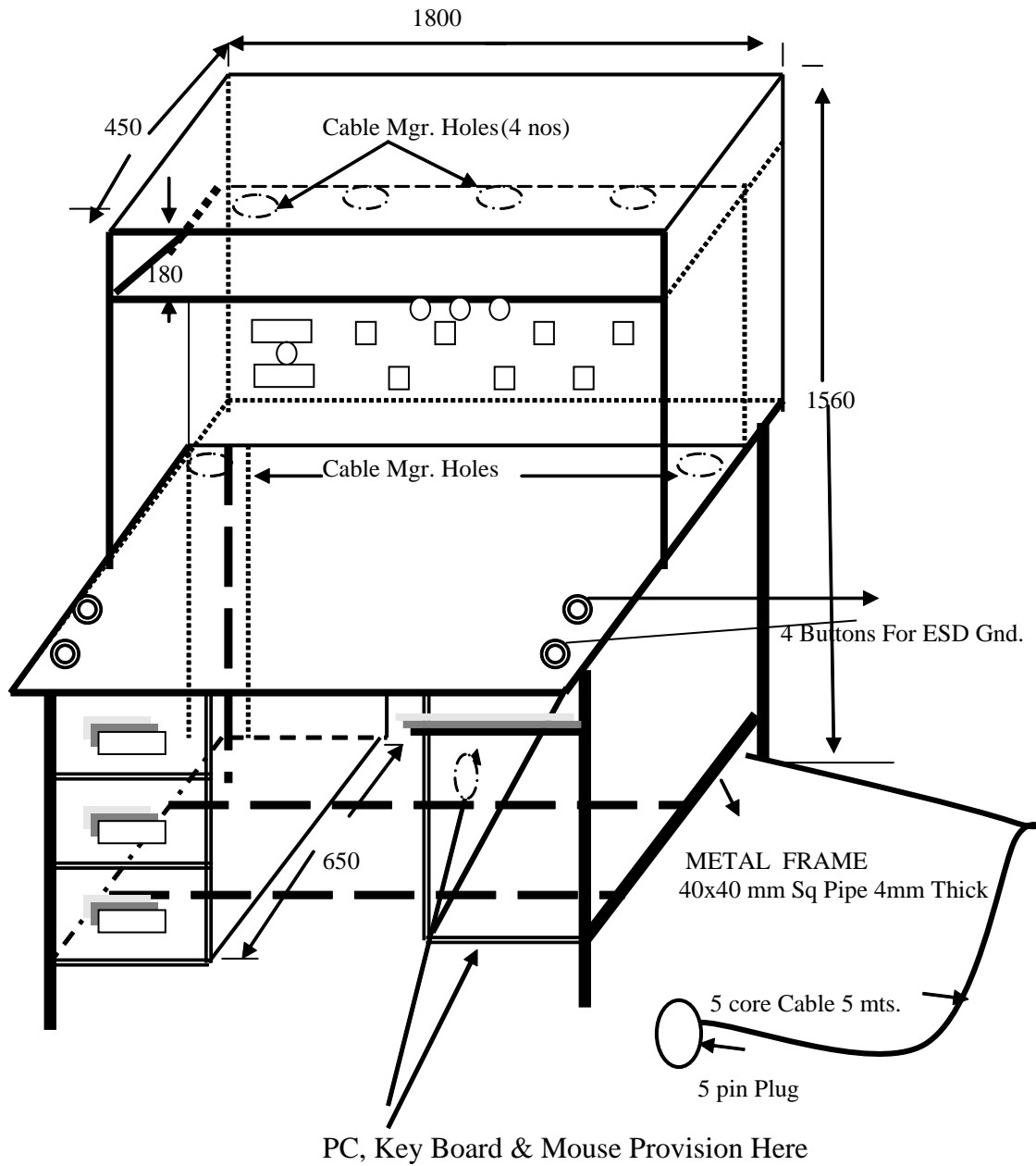

Drawer = All three drawers of equal size.

All dimensions are in mm

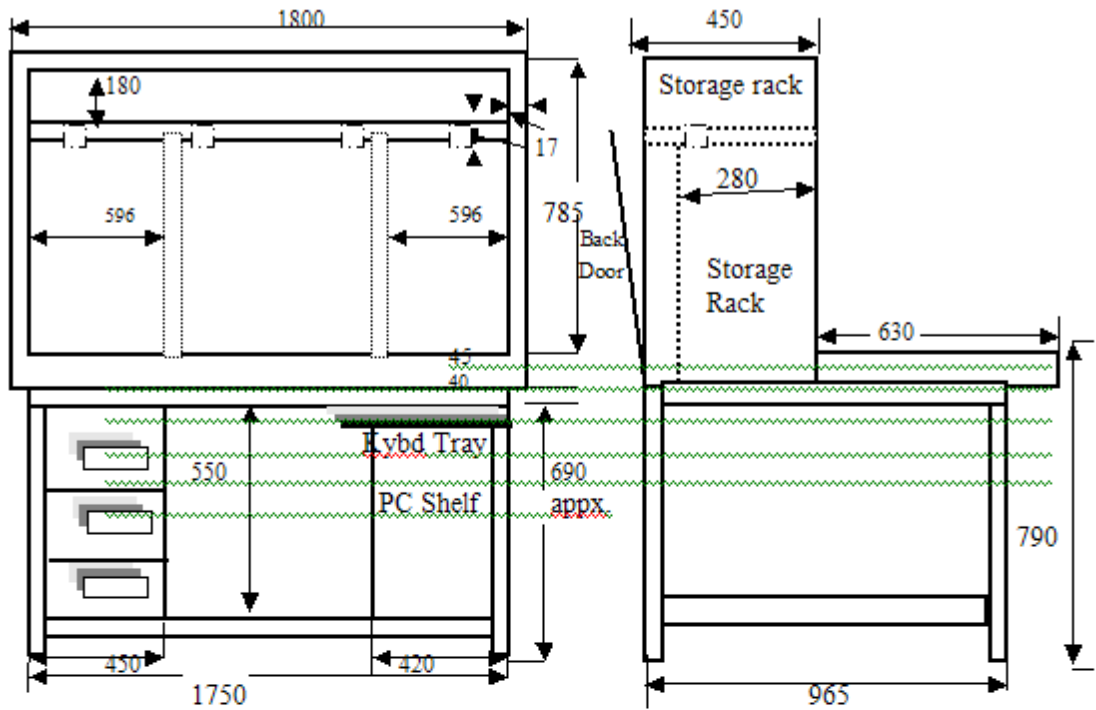

FRONT VIEW

SIDE VIEW

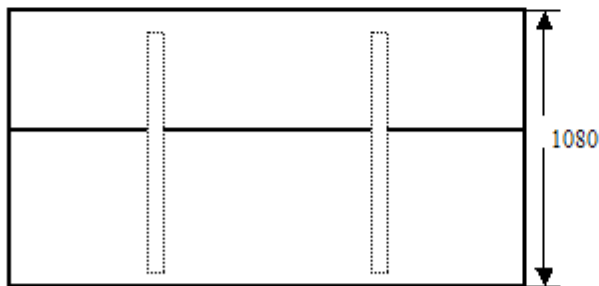

TOP VIEW

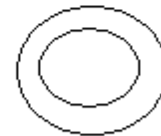

OD=15mm
ID=10mm
ESD Button (RIVET)

All Dimensions are in mm

Dr. No. PCB_T - PRO - 0601B

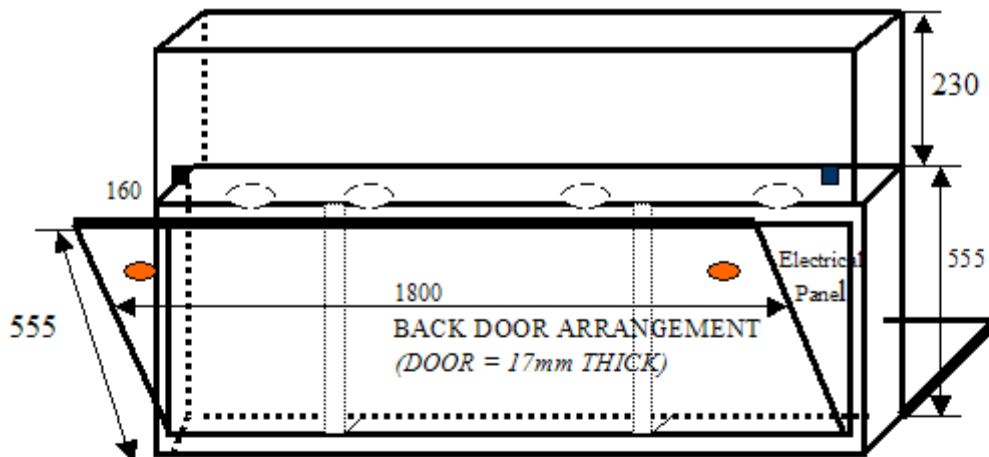

Fig. 1. BACK DOOR ARRANGEMENT

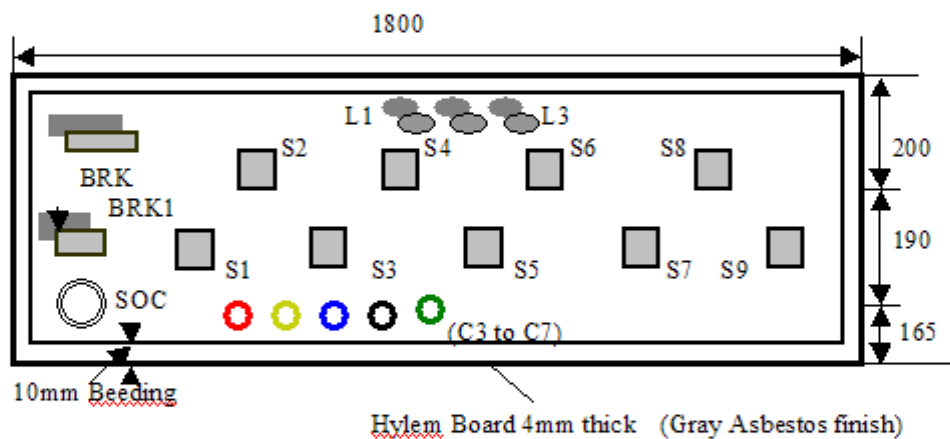
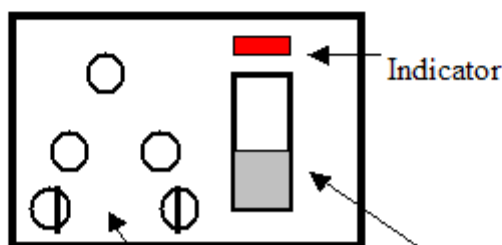

Fig. 2. Electrical Panel Layout.

For wiring refer wiring diagram.
All dimensions are in mm



240V 6A/16A Multi pin Universal socket / 240V 6A/16A Piano switch (SP)

S1 to S9 on Fig. 2.

Drg. No. PCB_T - PRO - 0601B

BRK = 15A 3PH CBK with ELCB

L1 to L3 = 240V lamps with

R Y B covers

C3- C7 = 4mm Sockets (R, Y, B, N, E)

for 3Ph Variac output

BRK1 = 15A 3phase CBK (ISI)

SOC = 3Ph CUTLER HAMMER

5pin 16A socket

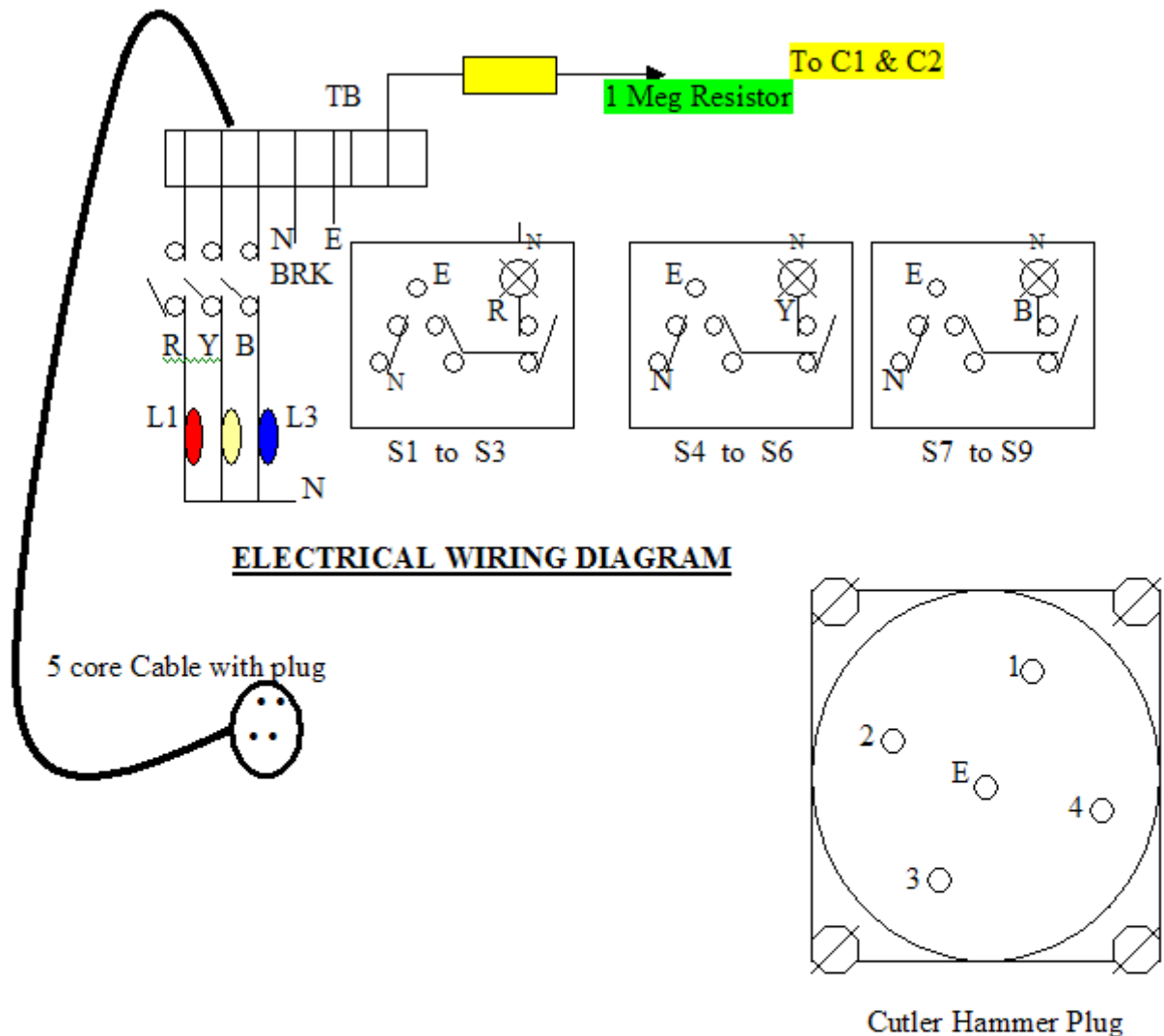

WIRING:

01. 5 Pin Cutler Hammer Plug Cable(External Power) to TB, & thru BRK to S1-S9
02. TB thru BRK to BRK1 to Cutler Hammer Socket 'SOC'
03. TB to 5 Pin Cutler Hammer Socket inside Electrical Panel.
(for Power Extension to other workstations)

Drg. No. PCB_T – PRO – 0601B