



CORPORATE PURCHASING SPECIFICATION

AA 28129

REV NO. 04

PREFACE SHEET

**PAPER COVERED CONTINUOUSLY TRANSPOSED COPPER CABLE
(0.1% PROOF STRESS)**

FOR INTERNAL USE ONLY
REMOVE THIS PREFACE BEFORE ISSUE TO SUPPLIERS

Comparable standards :

- | | | |
|------------------|-----------------------------|---|
| 1. INDIAN | : IS : 13730 PT – 17 – 1996 | ↑ |
| | : IS : 13730 PT – 27 – 1996 | |
| 2. INTERNATIONAL | : IEC : 60317 – 17 – 1990 | ↑ |
| | : IEC : 60317 – 27 – 1990 | |

Suggested/Probable Suppliers And grades :

1. M/S. Incab Industries Ltd . , Jamshedpur
2. M/S. ASTA Eisen und Gmbh , Austria
3. M/S. Lackdrath und gmbh , Germany
4. M/S. Invex Fillusolati Specicate SPA, Italy
5. M/S. Smith Drad , Netherland

User Plants And Replaced Plant Specifications / references :

1. BHOPAL -----
2. JHANSI -----

Revision : Cl. 34.1.19 of MOM of MRC (E)			APPROVED : INTER PLANT MATERIAL RATIONALISATION COMMITTEE- MRC (E)		
Rev.No. 04	Amd.No.	Reaffirmed	Prepared BHOPAL	Issued Corp. R&D	Dt.of Ist Issue Aug. 1987
Dt :19.05.07	Dt:	Year:			

COPYRIGHT AND CONFIDENTIAL
The information on this document is the property of Bharat Heavy Electricals Limited .
It must not be used directly or indirectly in any way detrimental to be interest of the company

	CORPORATE PURCHASING SPECIFICATION	AA 28129
		REV NO . 04
		PAGE 1 OF 9

**PAPER COVERED CONTINUOUSLY TRANSPOSED COPPER CABLE
(0.1% PROOF STRESS)**

1. GENERAL :

This specification governs the quality requirements of paper covered continuously transposed copper conductor (CTC) incorporating a number of individual work hardened copper strips insulated with a polyvinyl – acetal based enamel of fine grade and covered over all with not less than three layers of paper and suitable for use in hot insulated oil. Paper shall conform to BHEL corporate purchase specification (CPS) No. AA 21111 or AA 21116. The material in insulating oil have temperature index of 105 .

2. APPLICATION :

Used for windings of Transformers .

3. COMPLIANCE WITH NATIONAL STANDARDS

There is no National Standard for this type of material . However assistance has been derived from the following standards .

IS : 13370 Pt. 17, 1996/	- Specification for particular type of winding wires -	↑
IEC : 60317-17,1970	Pt. 17 - Polyvinyl Acetal enameled Rectangular .	
	Copper Wires. Class 105	

IS : 13730 Pt.27 – 1996 /	- Specification for particular Type of winding wires	↑
IEC : 60317 - 27 – 1990	Pt. 27 - Paper covered Rectangular Copper Wire .	

4 . TEST SAMPLES :

4.1 Paper :

The supplier shall send the test certificate for papers for all the tests as per BHEL Corporate Purchase Specification (CPS) No. AA 21111 or AA 21116 for our approval. The test report shall be sent for each lot of paper and of different thicknesses received from the paper mill , which are to be used in the manufacture of BHEL paper covered continuously transposed copper cable .

In the absence of proper test certificate 20 sheets of size 300X300 mm of paper from each lot and of different thicknesses shall be supplied for out testing.

Revision : CI.34 .1.19 of MOM of MRC (E)			APPROVED : INTER PLANT MATERIAL RATIONALISATION COMMITTEE- MRC (E)		
Rev.No. 04 Dt :19.05.07	Amd.No. Dt:	Reaffirmed Year:	Prepared BHOPAL	Issued Corp. R&D	Dt.of Ist Issue Aug . 1987

COPYRIGHT AND CONFIDENTIAL
 The information on this document is the property of Bharat Heavy Electricals Limited .
 It must not be used directly or indirectly in any way detrimental to be interest of the company



CORPORATE PURCHASING SPECIFICATION

AA 28129

REV NO. 04

PAGE 2 OF 9

4.2 Finished Conductor

3 metre long sample of CTC shall be supplied for testing and inspection.

5. CONDUCTOR:

5.1 CTC of any size given in Transformer standard sheets shall be ordered. Maximum and minimum dimensions of bare cable shall be as per these individual orders. Conductor size, No. of parallels and radial paper covering shall be stated on the order.

5.2 Radial insulation shall be from 0.20 to 3.0 mm, both inclusive.

5.3 Bunched CTC consisting of 2 or more individual stacks of any size indicated in Transformer Standard sheets shall also be ordered whenever required.

6. LENGTH & WEIGHT OF CABLE:

6.1 The total weight of cable, the length of cable per drum and the total No. of drums shall be as stated on the order. Length of cable per drum specified in our order is very important and so, it shall neither be less nor more than the specified.

6.2 Weights indicated in our orders are nominal and can vary within ± 2 percent considering allowed tolerances on dimensions and on corner radius.

Excess weights more than 2 percent shall not be admissible under any circumstances.

7. TYPE OF ENAMEL COVERING:

Fine grade. However in exceptional cases when medium grade of covering is required, it shall be stated on the order.

8. CONDUCTOR:

8.1 Grade of Material:

The conductor shall be manufactured from ETP grade copper conforming to BHEL Corporate Purchasing Specification (CPS) AA 12024.

Note : Manufacture of the Copper conductors from continuous cast copper bars is preferable provided all other acceptance parameters and conditions remains same.

The conductor shall fully conform to IS : 13730 Pt. 27 - 1996 except 0.1% proof stress and resistance. The 0.1 % Proof Stress of the conductor after removal of paper when tested as per IS:1608 shall be as given below :

<u>Nominal Value</u>	<u>Tolerance</u>
115, 135 & 145 Mpa .	+15% , - 10%



CORPORATE PURCHASING SPECIFICATION

AA 281 29

REV NO.

PAGE 3 OF 9

Tests shall be carried out on one sample taking 50 mm gauge length .However the conductor with any other nominal value of 0.1% proof stress can also be ordered .

8.2 ELECTRICAL RESISTIVITY:

The resistivity at 20 °C, when measured directly on the sample in "as received" condition shall not be greater than 0.01777 ohm/mm²/m. Refer Appendix "B of IS : 613 for temperature correction factor.

8.3 Enameled conductor :

The enameled conductor shall comply with fine grade of covering to IS :13730 Pt. 17, Î with the exceptions as given below :

8.4 Joints :

8.4.1 Joints in Bare Conductor :

Joints shall not be made in the conductor after it is drawn . Any joint made during the drawing process shall be resistance welded .

8.4.2 Joint in Enameled conductor : Î

If a joint in the enameled conductor becomes unavoidable due to breakage accidental stoppage of machine or when the specified length is in excess of the capacity of transposing machine bobbins, it shall be made by resistance welding , care being taken to ensure that the joint is made sound . All surplus weld shall be removed by filing and the joint finished with emery cloth / paper to give a smooth clean surface after Î which it shall be patch enameled . Any joint shall be insulated from the adjacent strips by a single piece of 100 micron thick paper half overlapped . Joints in the individual strips shall be staggered so that the distance between individual joints along the cable shall not be less than 150 mm. A red tag shall be tied at the joint portion of cable for identification and inspection . Any such joint shall be made only after prior approval of BHEL .

9. PAPER:

9.1 Grade of Paper:

Kraft paper shall conform to BHEL Corporate Purchasing specification (CPS) No. AA 21111 or AA 21116. If kraft / manila mixture or any other paper is used, it shall conform to BHEL Corporate Purchasing Specification (CPS) No. AA 21111 or AA 21116.

9.2 Thickness:

The thickness of paper shall be within limits of 50 and 140 um both inclusive.



CORPORATE PURCHASING SPECIFICATION

AA 28129

REV NO. 04

PAGE 4 OF 9

10. CONSTRUCTION OF TRANSPOSED CABLE:

10.1 Cleanliness of Enameled Conductor:

The enameled conductor shall be free from copper dust and other extraneous matter prior to transposing and covering with paper.

10.2 Transposition of Enameled Conductor:

The cable shall be manufactured from any odd number of enameled conductors from a minimum of 5 to a maximum of 31, according to the size of the individual conductor and the overall size of the cable as specified in the order.

The cable shall be formed by placing the strips into two stacks, the stacks, being edge to edge and the whole group of strips being continuously transposed along the length of the cable.

The pitch of successive transpositions shall be approximately 15 times the width of bare strip subject to a minimum of 50 mm. Lay i.e. the distance over which a strip resumes its original position in the conductor shall be equal to pitch multiplied by the number of strips.

For cables of radial depth 10 mm and above it shall have an intercolumn paper (paper spacer) inserted between the vertical stacks of strip. This paper shall comply with clause 9 and thickness shall be 100 um. Width of the paper spacers shall not be less than the value calculated from the following formula.

$$\text{Width} = \frac{(\text{Number of strips} - 1)}{2} \times \text{thickness of enameled strip}$$

10.3 Application of Paper Covering:

10.3.1 General:

Each layer of paper shall be continuous, firmly applied and substantially free from creases. No bonding or adhesive material shall be used except to anchor the ends of paper. Any such bonding or adhesive material shall have no deleterious effect on transformer oil, insulating paper, or electric strength of the covering. When papers of different thickness are used, the outermost paper shall be the thickest. The thickness of the paper shall be progressively increased from the innermost to the outermost layer.

10.3.2 Width of paper:

The width of paper shall be within the limits of 15 and 40 mm, both inclusive.

10.3.3 Arrangement of layers:

All the layers shall be applied in the same direction, all except the two outermost layers shall be butt wound and the two outermost layers shall be applied together with a staggering of 50% so that they are interlocked giving 50% overlap effect. Within each group the positions of the butt joints of any layer relative to the layer below shall be progressively displaced by approximately 30 percent of the paper width.



10.3.4 PAPER THICKNESS FOR BUTT AND OVERLAP INTERLOCKED WOUND LAYERS:

Thickness of paper for butt wound layers shall be between 50 μm and 100 μm (both inclusive) Two outermost overlap interlocked layers shall be wound with paper of thickness between 75 and 125 microns (both inclusive). However, when radial insulation is 2.2 mm or more, 140 μm paper for two outermost layers is allowed to avoid two paper covering operations due to availability of a maximum of 24 paper heads in the lapping machine of same manufactures. Special extensible high density and high mechanical strength paper meeting the requirements of clause 9 can be used in the two outermost interlocked layers.

11. DIMENSIONS OF TRANPOSED CABLES :

11.1 Method of Calculating Maximum Bare Axial Width (AW) :

$$AW = 2(b + e) + F + \text{inter column paper if specified (100 } \mu\text{m thick)}$$

Where

$$AW = \text{Max. bare axial width of transposed cable.}$$

$$b = \text{Maximum axial width of bare individual conductor} \\ = \text{Nominal width} + \text{Tolerance (from table 1 below)}$$

$$e = \text{Maximum increase in dimension due to enameling} \\ (\text{as per IS : 13730 Pt. 0 /Sec. 2 : 1993 (R-2003), IEC 60317-0-2:2005}) \\ = 0.11 \text{ mm for fine grades of covering}$$

$$F = \text{Free space allowance} = 0.4 \text{ mm}$$

Table 1 - Tolerances on Nominal Dimensions - (IS :13730 Pt. 27 : 1996)

Dimension (Width or Thickness), mm		Tolerances \pm mm
Over	Up to and including	
-	3.15	0.030
3.15	6.30	0.050
6.30	12.50	0.070
12.50	16.00	0.100

11.2 Method of calculating Maximum Bare Radial Depth (RD)

$$RD = \frac{N+1}{2} (T + e) + \text{free space allowance (from Table 2)}$$

Where

$$RD = \text{Maximum bare radial depth of Transposed Cable.}$$

$$T = \text{Maximum thickness of bare individual conductor} \\ = \text{Nominal thickness} + \text{Tolerance (from table 1 in cl.11.1)}$$

$$N = \text{Number of conductors in parallel}$$

$$e = \text{Maximum increase in dimensions due to enameling} \\ (\text{as per IS : 13730 Pt. 0/Sec 2 : 1993 (R 2003), IEC 60317-0-2 : 2005}) \\ = 0.11 \text{ mm for fine grade of covering.}$$



TABLE 2 - FREE SPACE ALLOWANCE - RADIAL DEPTH (mm)

No. of conductors	Free space allowance radial depth, mm	
	Thickness 1 -- 2 mm	Thickness 2.1 -- 3.15 mm
5 -11	0.28	0.63
13	0.30	0.70
15	0.33	0.78
17	0.36	0.85
19	0.39	0.90
21	0.42	1.00
23	0.44	1.05
25	0.50	1.15
27	0.55	1.25
29	0.60	1.40
31	0.65	1.50.

11.3 Method of Calculating Maximum Axial Width & Radial Depth with Paper Covering:

$$\text{Maximum covered Axial Width} = AW + t$$
$$\text{Maximum covered Radial Depth} = RD + t$$

Where AW is taken from Clause 11.1

RD is taken from Clause 11.2

t = nominal increase in dimensions due to paper covering taken from Cl. 11.4.

11.4 Increase in Dimensions due to paper covering:

11.4.1 Increase in Dimensions:

The increase in dimensions due to covering shall have tolerance indicated below:

Increase due to covering (mm)		Tolerance %
Over	Up to & including	
-	0.5	+0 - 10
0.5	1.3	+0 - 7.5
1.3	-	+0 - 5

11.4.2 Measuring Equipment :

The measurement shall be made with a suitable ratchet micrometer . The spindle and anvil of the micrometer shall have a diameter of 5 to 8 mm .



11.4.3 Measuring Method:

Covered Dimension shall be measured at three positions not less than 100 mm apart.. The measurements shall be made on completely straight parts of the transposed cable. The measurement shall include at least one over lap. The covering shall be removed by any method which does not damage the conductor for three positions used for the measurement of "Covered Dimensions" and "Bare Dimensions" measured at these positions. The average of the three results shall be reported as "bare dimension". The difference between "Covered Dimension" and the "Bare Dimension" shall be reported as the increase in dimension due to covering.

11.4.4 Counter Check:

The increase in dimension due to covering shall also be counter checked by adding up the thickness of paper used in each layer. The thickness of paper shall be measured by dead weight micrometer conforming to IS: 1060 (Part 1) by stacking the tapes of paper one above the other. Paper tape shall not be folded to form two or more tapes. Length of paper tapes shall not be less than 150 mm. Five measurements shall be made distributed over the stack. The paper thickness shall be computed by dividing by five the mean of five readings.

Radial insulation so computed in 11.4.4 shall not be less than the minimum allowed (considering the appropriate tolerance) as per 11.4.1.

12. TESTS ON FINISHED CABLES:

12.1 Insulation Faults Between Strips :

The insulation test at 250 V, AC for 1 minute shall be conducted on all drums between each and every other strip in CTC stack. There shall be no fault in the insulation. In case of bunched (twin) CTC, this test shall also be conducted between two stack.

13. TEST CERTIFICATE:

Unless otherwise stated three copies of the test certificate shall be supplied along with each consignment,

In additional the supplier shall ensure to enclose one copy of test certificate along with their dispatch documents to ensure quick clearance of the material.

The test certificate shall bear the following information

AA 28129 : Paper covered continuously Transposed Copper Cable. (0.1% Proof Stress) (Rev. 04) Covered & Bare Dimension of cable, No. and size of individual conductor, increase in dimensions due to paper covering, number of paper layers and thickness of paper in each layer, grade of enamel and length of cable shall be indicated in the test certificate.

BHEL Order No.

Manufacturer's / Supplier's name

Trade mark, if any

Batch No./Lot No

Test results of enameled and covered transposed cable as per Cl. 5, 8 to 12.



CORPORATE PURCHASING SPECIFICATION

AA 281 29

REV NO. 04

PAGE 8 OF 9

Test certificates for compliance of characteristics of paper to BHEL Corporate Purchasing Specifications (CPS) No. AA 21111 and AA 21116.

14. PACKING AND MARKING:

The transposed cable shall be tightly and evenly wound, without twist, on drums in such a direction that when unrolled the exposed edge of the overlap of the outer layer of paper is towards the drum. The size of drum shall be selected from Annexure I. Drum flanges shall have an arrow mark showing the position of finishing end of cable.

Barrel dia 'C' of drum shall be at least 50 times of covered radial depth of cable subject to a maximum of 900 mm (Barrel 14) When specified on order, drums of barrel dia 1070 & 1140 mm shall be used. Out side flange dia A of drums can be reduced by the supplier considering the packing weight of CTC and capacity of the drum. However, it shall be ensured that cable is not packed up to the rim of the drum.

Before winding the insulated strip, a layer of polythene sheet or similar waterproof material shall be wrapped on empty drum. After winding the cable, the sheet edges shall be folded over the cable and then a polythene strip shall be wound on outside.

As a final protection, a layer of oiled canvas or similar waterproof material shall be wrapped over the polythene sheet, ensuring that no part of the cable is exposed.

Drums used for packing shall be made from seasoned wood. Circular disc separator shall be made from plywood.

Metal/Non –Metal straps used over, the drum shall be stamped/sealed with the manufacturer's identification marks. Similarly, end of the conductor shall also be stamped/sealed.

Each drum shall be labeled clearly stating the following information. The label shall preferably be cemented into a recess in the side of the flange of the drum.

AA 28129 - Paper Covered continuously Transposed Copper Cable. (0.1% Proof Stress)

BHEL Order No.
Manufacturer's Name / Suppliers Name

Maximum covered and bare dimension of cable, No. and size of individual conductor, increase in dimensions due to paper covering, No. of paper layers and thickness of paper in each layer, grade of enamel and length of cable.

Batch No./Lot No..
Net weight / Gross weight.

15. REFERRED STANDARDS (Latest Publication Including Amendments) :

↑

- | | | | |
|-------------------|-----------------|-------------------|----------------|
| 1. AA 21111 | 2. AA 21116 | 3. AA 12024 | 4. IS:13730-17 |
| 5. IS:613 | 6. IEC 60317-17 | 8. IEC : 60317-27 | 9. IS:1060 |
| 10 IS:13730 Pt.27 | 11 IS:1608 | | |

ANNEXURE - I

Dimensions of Standard Drum

DIMENSION		Drum Designation						
		8	9	10	14A	14B	14C	14D
Outside Flange diameter	A	800	900	1000	1400	1400	1400	1400
Barrel dia	C	600	600	700	900	900	900	900
Overall width	D	440	440	660	440	710	910	580
Traverse	B	340	340	560	340	610	810	480
PCD of Driving Holes	J	300	300	600	600	600	600	600
Flange depth	G	88	138	138	238	238	238	238
Approximate Capacity in Kg.		300	480	890	1230	2200	2900	1730

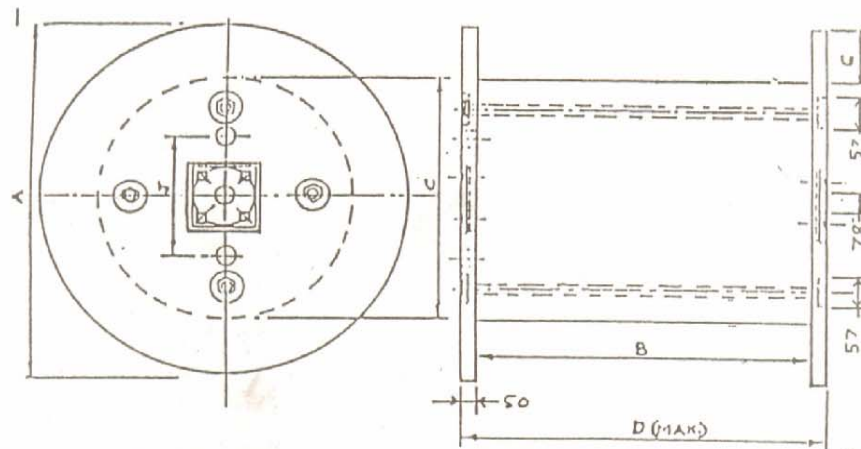

- NOTE:**
1. Partitions to hold multiple length in a drum shall be of 12.5 mm thick.
 2. Any fixing bolt used within a circle of 600 mm diameter shall not project outside flange surface.

Note:

1. Partitions to hold multiple length in a drum shall be of 12.5 mm thick.
2. Any fixing bolt used within a circle of 600 mm diameter shall not project outside flange surface.