



उत्पाद मानक (हीप - हरिद्वार)

PRODUCT STANDARD (HEEP HARIDWAR)

HE 57008

पृष्ठ का
Page 1 of 11

AIR EXHAUSTER WITH MOTOR (RADIAL VENTILATOR)

BASED ON BHEL'S
OWN EXPERIENCE

1.0 SCOPE :

This specification covers the design, manufacture, performance requirements, testing and supply conditions of Air Exhauster with motor for sucking air steam mixture from gland steam condenser in a thermal power station.

1.1 DESIGNATION :

While raising purchase indent, mention the type (see Table-1, Page-6) e.g. Air Exhauster with Motor - Type A to HE 57008.

2.0 TECHNICAL DATA :

2.1 EXHAUSTER DATA :

- 2.1.1 Medium to be handled : Air steam mixture
- 2.1.2 Suction temperature : See Table - 1.
- 2.1.3 Maximum Temperature : 100 °C
- 2.1.4 Total pressure : See Table - 1
- 2.1.5 Flow volume : See Table - 1
- 2.1.6 Density of air steam mixture : See Table - 1
- 2.1.7 Housing position : See Figure - 1

2.2 MOTOR DATA:

- 2.2.1 Rated output : To be indicated by the supplier.
- 2.2.2 Ambient Temperature : 50 °C
- 2.2.3 Supply : 415 Volts, 3Phase, 50C /s.
- 2.2.4 Type of enclosure : Totally enclosed fan cooled
- 2.2.5 Type of protection : IP 54 (IS:4691)
- 2.2.6 Mounting : As per figure 1
- 2.2.7 Starting : Direct on line
- 2.2.8 Voltage Variation : +/- 10%
- Frequency Variation : +/- 5%
- Combined voltage & frequency variation : +/- 10%
- 2.2.9 Insulation Class : B
- 2.2.10 Efficiency Class of motor : Premium Efficiency Class IE3 conforming to IS 12615 or IEC:60034-30

दिनांक एवं हस्ताक्षर
SIGN & DATE

SUPERSEDES
INVENTORY
NO.

सामग्री सूची
संख्या को
अधिकारित

COPYRIGHT AND CONFIDENTIAL
The information on this documents is the property of Bharat Heavy Electrical Limited. It must not be used directly or indirectly in any way detrimental to the interest of the company

स्वत्वाधिकार एवं गोपनीय
इस परलेख में दो गई सूचना भारत हेवी इलेक्ट्रिकल्स की संपत्ति है, इसका प्रचलन एवं अप्रचलन रूप से किसी भी तरह प्रयोग, जो कि कंपनी के हित में हानिकारक हो न किया जाए।



हस्ताक्षर एवं दिनांक
SIGN & DATE

सामग्री सूची संख्या
INVENTORY NO.

			नाम NAME	दिनांक एवं हस्ताक्षर SIGNATURE & DATE
TSX	D.K. Mandal	<i>Deepalata</i> 21/02/16	अनुवादक TRANSLATED BY	
			निर्माणकर्ता WORKED BY	TARUN BANSAL <i>TB</i> 22/01/16
QAX	VIBHUTI SHAH	<i>Vibhuti</i> 22/1/16	जांचकर्ता CHECKED BY	ROHIT BANSAL <i>Rohit</i> 22/1/16
सहमत विभाग AGREED DEPTT.	नाम NAME	दिनांक एवं हस्ताक्षर DATE & SIGNATURE	पर्यवेक्षणकर्ता SUPERVISED BY	SHASHI KANT <i>skant</i> 22/01/2016
			स्वीकृति APPROVED S.K. BAVEJA, AGM (HXE & PED)	G.P. No. 267
REV.NO.10	SUPERCEDES		निर्माण PREPARED : HXE	जारी ISSUED : TSX
Dt. 22.01.16				दिनांक 6/3/88

P-5718

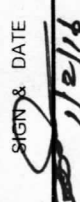
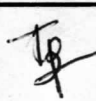
दिनांक एवं हस्ताक्षर SIGN & DATE सामग्री सूची संख्या की अधिकतम संख्या	 उत्पाद मानक (हीप - हरिद्वार) PRODUCT STANDARD (HEEP - HARIDWAR)	HE 57008						
		2.3 GENERAL REQUIREMENT : 2.3.1 The exhausters shall be supplied in pairs for each set , such that when two units (per set) are installed with motor fan axis coinciding in one line (horizontal), one unit shall be a mirror image of the other. (Refer Figure - 2). 2.3.2 Vibration of the equipment shall be limited to the maximum displacement of 50 microns. The measurement procedure shall be broadly as per IS: 12075. 2.3.3 Noise level shall not be more than 85 dB at a distance of 1 meter. Noise level test shall carried out generally as per IS: 12065. 2.3.4 Dynamic balancing of the impeller shall be done generally as per ISO: 1940 of the balance quality grade G6.3. 2.3.5 The impeller shall be zinc sprayed. (Minimum thickness 60 micron). 2.3.6 All the parts of the exhauster and motor shall be of corrosion resisting material or shall suitably and durably protected against corrosion. 2.3.7 Suitable foundation on bolts (M16 x110) along with nut (M16), lock nut (M16) Spring washer 4 nos. (each) shall be supplied by the vendor for mounting of the equipment on foundation. 2.3.8 Dimensional details shall be as per Figure -1 2.3.9 Each fan exhauster shall be performance test at supplier's works as per IS: 4894. 2.3.10 In the event of placement of order, General Arrangement drawing of the exhauster unit shall be got approved before starting manufacturing of Air Exhauster. 3.0 DESIGN, MANUFACTURE & WORKMANSHIP : 3.1 The protective measure of exhauster shall be as per of IS 4894. In assembled condition, live parts shall not be accessible with the standard test finger (see IS: 1401). 3.2 The welding of the equipment shall be carried out by a qualified welder as per ASME Sec-IX. 3.3 The motor shall have delta type stator winding connection. 3.4 Minimum voltage required under starting up conditions to bring exhauster up to rated speed shall be 85% of rated voltage. 3.5 Before starting manufacturing of Air Exhauster , the vendor shall get its detailed drawing approved by BHEL, which shall include detailed dimensions and bill of material. 3.6 Permissible variation in dimensions mentioned in Table-II shall be as follows: i) Nominal dimension : From 30 mm – 120 mm : +/- 2 mm ii) - do - : From 121 mm – 315 mm : +/- 2 mm iii) - do - : From 316 mm - 1000 mm : +/- 3 mm 3.7 To cater for continuous operational requirement at the power station, the air exhauster and motor shall be of proven design. 3.8 All flanged connections shall be supplied with matching counter flanges along with fasteners to permit trouble free assembly of inter connecting pipelines. 4.0 MATERIAL : The material of construction used should satisfy the operational stresses, i.e. mechanical, thermal and chemical. It should be certified by the supplier that the material quoted by them in the part list has been used and is suitable for intended service requirements.	पृष्ठ का Page 2 of 11					
COPYRIGHT AND CONFIDENTIAL The information on this documents is the property of Bharat Heavy Electrical Limited. It must not be used directly or indirectly in any way detrimental to the interest of the company	स्वत्वाधिकार एवं गोपनीय इस प्रलेख में दी गई सूचना भारत हवी इलेक्ट्रिकल्स की सम्पत्ति है इसका प्रत्यक्ष एवं अप्रत्यक्ष रूप से किसी भी तरह प्रयोग, जो कि कम्पनी के हित में हानिकारक हो न किया जाए।		सामग्री सूची INVENTORY NO. 1-5718	REV.NO. 10	निर्माणकर्ता WORKED BY TARUN BANSAL	जाँचकर्ता CHECKED BY ROHIT BANSAL	SD/-	SD/-

दिनांक एवं हस्ताक्षर SIGN & DATE		उत्पाद मानक (हीप - हरिद्वार) PRODUCT STANDARD (HEEP - HARIDWAR)	HE 57008	
सामग्री सूची संख्या को अधिकृत किया करता। SUPERSEDES INVENTORY NO.	5.0 DATA REQUIRED WITH THE BID / OFFER: Supplier to furnish the following data / documents in duplicate along with the offer : 5.1 The general arrangement drawing & catalogue / literature relevant to the product. 5.2 Part lists 5.3 Data sheets duly filled in formats attached with this specification. Foundation drawing along with embossment details of the foundation bolts etc. 5.4 The list of recommended spares required for a period of 5 years.			
COPYRIGHT AND CONFIDENTIAL The information on this documents is the property of Bharat Heavy Electrical Limited it must not be used directly or indirectly in any way detrimental to the interest of the company	6.0 IDENTIFICATION : 6.1 The fan exhaustor with motor assembly should have name plate of corrosion resistant material and must include the following information : 6.1.1 Name of equipment. 6.1.2 Model No. 6.1.3 Motor rating. 6.1.4 Name of supplier 6.1.5 BHEL specification No He 57008. 6.1.6 Identification SI No. 1 or 2, as shown in Figure-2 6.1.7 Power factor. 6.1.8 Weight of the equipment. 6.2 The direction of rotation should be embossed on the equipment at an easily locating position.			
स्वत्वाधिकार एवं गोपनीय इस दस्तावेज में दी गई सूचना भारत भारती इलेक्ट्रिकल्स की सम्पत्ति है इसका प्रयोक्ता एवं अप्रयोक्ता रूप से किसी भी तरह प्रयोग, जो कि कंपनी के हित में हानिकारक हो न किया जाए।	7.0 INSPECTION AND TESTING: 7.1 The final inspection shall be carried out by BHEL'S representative. A notice of minimum 4 weeks shall be given by supplier for witnessing tests / checks for each lot of air-exhauster with motor. Representative shall have free access to the supplier's works for the purpose of inspection and testing of the air exhauster with motor, and vendor shall provide him all necessary help in carrying out the inspection. Approval of tests / inspection and there by issue of test certificates, or waiver of inspection by the purchaser shall not relieve the vendor of his responsibilities and obligations under contract for safe and satisfactory performance of the fans. 7.2 Tests listed under clause 7.3 shall be carried out as per procedures laid down in IS : 4894. If facilities for any of the tests mentioned below does not exist with the supplier, then relevant test certificates issued by approved test laboratories / institutes shall be supplied in original. Supplier shall supply all test certificates as listed in clause no 7.3.			
अक्षरों एवं दिनांक SIGN & DATE 	7.3 Minimum tests / checks to be carried out on air exhauster, are given below.			
सामग्री सूची संख्या INVENTORY NO. P-5718	REV.NO. 10		निर्माणकर्ता WORKED BY TARUN BANSAL	SD/- 
			जांचकर्ता CHECKED BY ROHIT BANSAL	SD/- 

SUPERSEDES INVENTORY NO.

7.3.1 AIR EXHAUSTER:

- i. Air delivery test to meet the requirement of clause 2.3.9.
- ii. Vibration test, to meet the requirement of clause 2.3.2.
- iii. Noise level test, to meet the requirement of clause 2.3.3.
- iv. Dimensional Check
- v. Material check: Material certificate shall be as per approved drg. / material list by BHEL.
- vi. Fan speed (Acceptance test).
- vii. Balancing of rotating parts to meet the requirements of clause 2.3.4
- viii. 100% soap bubble test shall be carried out for no leakage of Casing & Gasket joints at design pressure.

7.3.2 : MOTOR:

- (a) TYPE TESTS:
 - i. Temp. rise test.
 - ii. Full load test.
- (b) ROUTINE TESTS
 - i. High voltage test.
 - ii. Insulation resistance test.
 - iii. Earthing continuity test
 - iv. Electrical input test.

7.4 TOLERANCE ON RATINGS :

The difference between the observed test results and the ratings assigned by the manufacturer shall not exceed the tolerances given below :



- a) Air delivery (-) 10 %
- b) Electrical input (+) 10%
- c) Speed (+/-) 10 %
- d) Deficiency (-) 15%.



8.0 DOCUMENTS REQUIRED ALONG WITH SUPPLY OF EXHAUSTER UNIT SET :

- 8.1 Certified copies of test results of tests listed under paragraph 7.2.& 7.3 in 5 copies.
- 8.2 Dimensional drawings showing erection details in 5 nos.
- 8.3 Operating and maintenance manual in 5 nos.
- 8.4 Packing lists.
- 8.5 Final data sheets on the format enclosed with this specification in 5 nos..
- 8.6 Guarantee certificate: The supplier shall guarantee trouble free operation of the equipment for a minimum period of one year after installation and undertake to replace / repair the damaged components free of cost with in the guarantee period.
- 8.7 A copy each of the above-referred documents, along with one reproducible of item at clause 8.2 shall be dispatched separately to BHEL, Hardwar before dispatch of consignment.

COPYRIGHT AND CONFIDENTIAL
 The information on this documents is the property of Bharat Heavy Electrical Limited. It must not be used directly or indirectly in any way detrimental to the interest of the company

स्वत्वाधिकार एवं गोपनीय
 इस प्रलेख में दी गई सूचना भारत हेवी इलेक्ट्रिकल्स की सम्पत्ति है इसका प्रत्यक्ष एवं अप्रत्यक्ष रूप से किसी भी तरह प्रयोग, जो कि कंपनी के हित में हानिकारक ही न किया जाए।

सामग्री सूची संख्या INVENTORY NO. 7-5718	REV.NO. 10		निर्माणकर्ता WORKED BY TARUN BANSAL	SD/- 	
			जांचकर्ता CHECKED BY ROHIT BANSAL	SD/- 	

दिनांक एवं हस्ताक्षर SIGN & DATE		<p style="text-align: center;">उत्पाद मानक (हीप - हरिद्वार)</p> <p style="text-align: center;">PRODUCT STANDARD (HEEP - HARIDWAR)</p>	HE 57008		
समूची सूची संख्या को अधिकृत करवा	SUPERSEDES INVENTORY NO.		पृष्ठ का Page 5 of 11		
<p style="text-align: center;">COPYRIGHT AND CONFIDENTIAL</p> <p style="text-align: center;">The information on this documents is the property of Bharat Heavy Electrical Limited. It must not be used directly or indirectly in any way detrimental to the interest of the company</p>	9.0 INTER CHANGEABILITY : The motor of the exhauster of a particular size and model and set of blades shall be Changeable such that the performance of the equipment remains within specified limits.	<p>10.0 QUALITY PLAN : Quality Plan shall be submitted along with the offer for approval. Prior approval of Quality Plan is necessary before manufacturing.</p> <p>11.0 PAINTING : The equipment is to be painted with the paints given below after cleaning the surfaces by shot blasting etc., giving a clean dry and metallic finish.</p> <p>11.1 INTERNAL SURFACES : Inner chamber of the exhauster are to be preserved with steam Washable preservation oil/ paint having viscosity of 38 centistokes at 40° c.</p> <p>11.2 OUTER SURFACES : Outer surfaces of exhauster shall be painted as per following details :</p> <p>I. Inland conditions: Process a) and c) as per details below to be used for inland application with final DFT as 100 microns.</p> <p>II. Sea Condition : Process a),b) and c) as per details below to be used with final DFT as 100 microns.</p> <p>a) Priming : Epoxy resin based 2 pack Zinc Phosphate with DFT 50 microns.</p> <p>b) Intermediate : TiO₂ pigmented epoxy resin intermediate paint.</p> <p>c) Finish : Epoxy resin based finish paint.</p> <p>12.0 DESPATCH :</p> <p>12.1 The exhauster units shall be directly dispatched to the site as described in the Purchase Order.</p> <p>12.2 All openings to be suitably blanked with blanking plates/counter flanges as specified in Cl. 3.8.</p> <p>12.3 All loose items to be packed separately in a small box and kept inside the main packing box for the exhauster units.</p> <p>12.4 Packing should be sea worthy and must be able to protect the equipment in tropical climate.</p> <p>12.5 Following information should be painted on the packing box :</p> <p>a) Name of the equipment.</p> <p>b) BHEL Purchase Order No.</p> <p>c) BHEL Specification No. HE-57008.</p>			
	<p>13.0 LIST OF CROSS REFERRED STANDARDS AND SPECIFICATIONS :</p> <p>a) ASME - IX b) ISO - 1940 c) IS - 1401</p> <p>d) IS - 4691 e) IS - 4894 f) IS - 12065</p> <p>g) IS - 12075 h) IS- 12615 i) IEC:60034-30</p>				
<p>स्वत्वाधिकार एवं गोपनीय</p> <p>इस प्रलेख में दी गई सूचना भारत हेवी इलेक्ट्रिकल्स की सम्पत्ति है इसका प्रत्यक्ष एवं अप्रत्यक्ष रूप से किसी भी तरह प्रयोग, जो कि कंपनी के हित में हानिकारक हो न किया जाए।</p>	<p>13.0 LIST OF CROSS REFERRED STANDARDS AND SPECIFICATIONS :</p> <p>a) ASME - IX b) ISO - 1940 c) IS - 1401</p> <p>d) IS - 4691 e) IS - 4894 f) IS - 12065</p> <p>g) IS - 12075 h) IS- 12615 i) IEC:60034-30</p>				
<p>समूची सूची संख्या</p> <p>INVENTORY NO.</p> <p>P-5218</p>	<p>REV.NO.</p> <p>10</p>	<p>निर्माणकर्ता</p> <p>WORKED BY</p> <p>TARUN BANSAL</p>	<p>SD/-</p> <p></p>	<p>जांचकर्ता</p> <p>CHECKED BY</p> <p>ROHIT BANSAL</p>	<p>SD/-</p> <p></p>

दिनांक एवं हस्ताक्षर SIGN & DATE



उत्पाद मानक (डीप - हरिद्वार)

HE 57008

PRODUCT STANDARD (HEEP - HARIDWAR)

पृष्ठ का
Page 6 of 11

सामग्री सूची संख्या INVENTORY NO.

COPYRIGHT AND CONFIDENTIAL
The information on this documents is the property of Bharat Heavy Electrical Limited. It must not be used directly or indirectly in any way detrimental to the interest of the company

स्वाधिकार एवं गोपनीय
इस प्रलेख में दी गई सूचना भारत हेवी इलेक्ट्रिकल्स की सम्पत्ति है इसका प्रत्यक्ष एवं अप्रत्यक्ष रूप से किसी भी तरह प्रयोग, जो कि कंपनी के हित में हानिकारक हो न किया जाए।

करताक्षर एवं दिनांक SIGN & DATE
[Signature] 11/2/16

सामग्री सूची संख्या INVENTORY NO.
P-5 P18

REV.NO.
10

TABLE-1

PARAMETERS	UNIT S	TYPE					E	
		A	B	C	A1	B1		C1
SUCTION TEMPERATURE	°C	70	80	84	70	80	84	80
HEAD DEVELOPED	mmW C	310	306	410	310	306	410	500
FLOW VOLUME	M ³ /se C.	0.3	0.4	0.3	0.3	0.4	0.3	0.7
DENSITY OF AIR STEAM MIXTURE AT SUCTION TEMPERATURE AND 85% RH	Kg/M ³	0.923	0.846	0.780	0.923	0.846	0.780	0.846

निर्माणकर्ता WORKED BY	TARUN BANSAL	<i>[Signature]</i>
जांचकर्ता CHECKED BY	ROHIT BANSAL	<i>[Signature]</i>

दिनांक एवं हस्ताक्षर SIGN & DATE



उत्पाद मानक (डीप - हरिद्वार)

HE 57008

PRODUCT STANDARD (HEEP - HARIDWAR)

पृष्ठ का
Page 7 of 11

सामग्री सूची संख्या को अधिकृत किया जाएगा
SUPERSEDES INVENTORY NO.

COPYRIGHT AND CONFIDENTIAL
The information on this documents is the property of Bharat Heavy Electrical Limited. It must not be used directly or indirectly in any way detrimental to the interest of the company

स्वत्वाधिकार एवं गोपनीय
इस प्रलेख में दी गई सूचना भारत हेवी इलेक्ट्रिकल्स की सम्पत्ति है। इसका प्रत्यक्ष एवं अप्रत्यक्ष रूप से किसी भी तरह प्रयोग, जो कि कंपनी के हित में हानिकारक हो न किया जाए।

हस्ताक्षर एवं दिनांक
SIGN & DATE

सामग्री सूची संख्या INVENTORY NO.
K-53-18

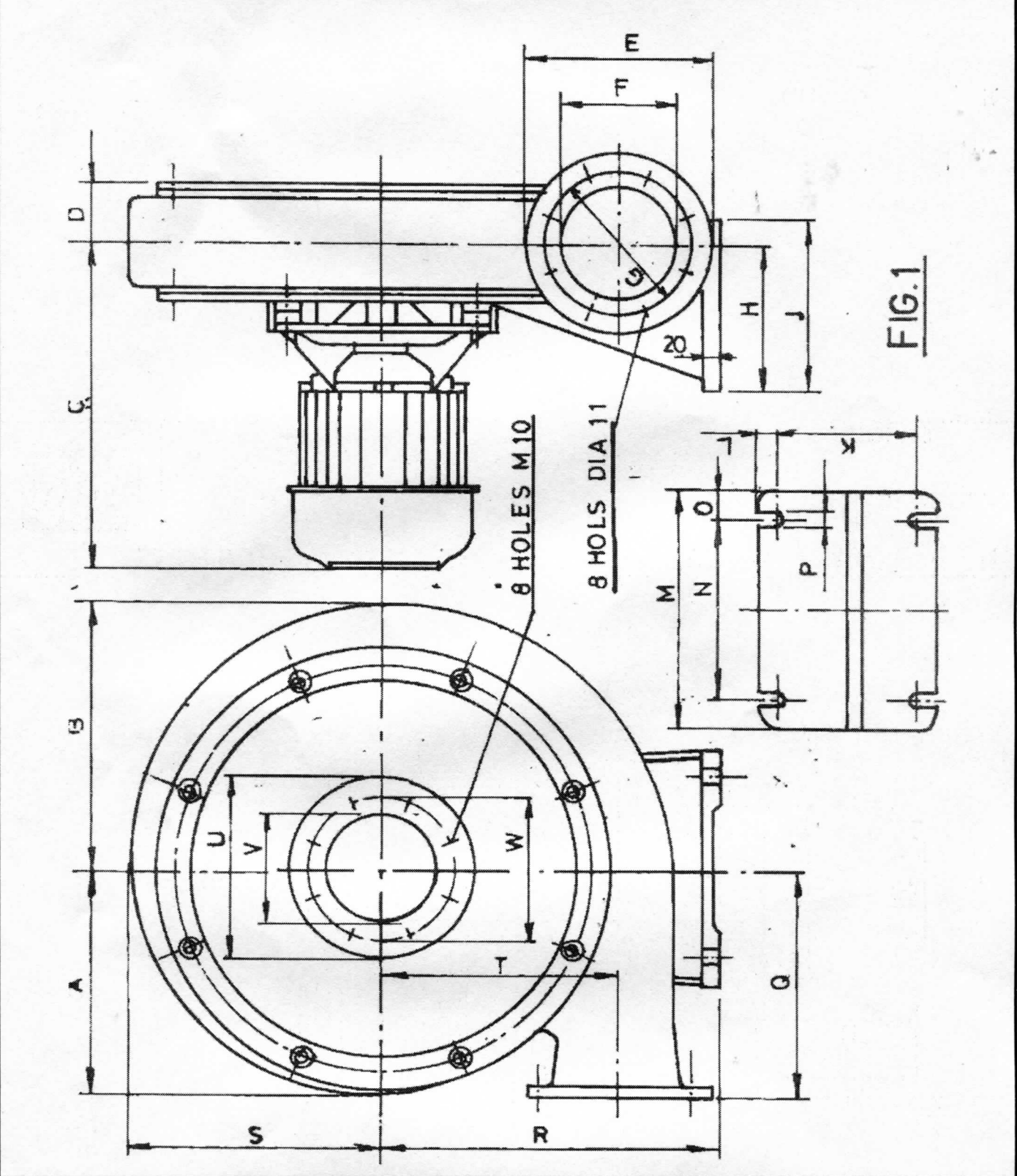

REV.NO.
10

निर्माणकर्ता
WORKED BY
TARUN BANSAL

जांचकर्ता
CHECKED BY
ROHIT BANSAL

SD/-
SD/-

[Signatures]

उत्पाद मानक (हीप - हरिद्वार)

HE 57008



PRODUCT STANDARD (HEEP - HARIDWAR)

पृष्ठ का
Page 8 of 11

DIMENSIONAL DETAIL OF FIGURE-1
DIMENSIONAL DETAIL OF FIGURE-1

SL NO	TYPE DIMENSION	A	B	C	A1	B1	C1	D	E
01	A	≈212	≈263	≈263	≈300	≈300	≈360	≈360	≈360
02	B	≈268	≈318	≈318	≈350	≈350	≈425	≈425	≈425
03	C	≈445	≈450	≈425	≈540	≈540	≈560	≈540	≈540
04	D	72	80	80	115	115	135	135	135
05	E	φ 216	φ234	φ234	φ234	φ234	φ274	φ280	φ280
06	F	φ140	φ160	φ160	φ160	φ160	φ200	φ200	φ200
07	G (PCD)	φ182	φ200	φ200	φ200	φ200	φ240	φ240	φ240
08	H	172	180	180	180	180	210	243	243
09	J	200	200	200	243	243	243	343	343
10	K	164	164	164	207	207	207	307	307
11	L	18	18	18	18	18	18	18	18
12	M	250	280	280	364	364	364	464	464
13	N	190	220	220	304	304	304	404	404
14	O	30	30	30	30	30	30	30	30
15	P	18	18	18	18	18	18	18	18
16	Q	215	270	270	320	320	380	400	400
17	R	330	390	390	440	440	530	530	530
18	S	≈240	≈284	≈284	≈325	≈325	≈390	≈390	≈390
19	T	220	267	267	310	310	370	370	370
20	U	φ216	φ234	φ234	φ234	φ234	φ274	φ280	φ280
21	V	φ140	φ160	φ160	φ160	φ160	φ200	φ200	φ200
22	W (PCD)	φ182	φ200	φ200	φ200	φ200	φ240	φ240	φ240

COPYRIGHT AND CONFIDENTIAL

The information on this documents is the property of Bharat Heavy Electrical Limited. It must not be used directly or indirectly in any way detrimental to the interest of the company

स्वत्वाधिकार एवं गोपनीय

इस प्रलेख में दी गई सूचना भारत हेवी इलेक्ट्रिकल्स की सम्पत्ति है इसका प्रत्यक्ष एवं अप्रत्यक्ष रूप से किसी भी तरह प्रयोग, जो कि कंपनी के हित में हानिकारक हो न किया जाए।

उत्पादक एवं दिनांक
SIGN & DATE

सामग्री सूची संख्या
INVENTORY NO.

REV.NO.
10

निर्माणकर्ता
WORKED BY

TARUN BANSAL

जांचकर्ता
CHECKED BY

ROHIT BANSAL

(Signature)

(Signature)

P-5718



2008/12/16

सामग्री सूची संख्या को अधिकृतित करना	SUPERSEDES INVENTORY NO.	
--------------------------------------	--------------------------	--

COPYRIGHT AND CONFIDENTIAL
 The information on this documents is the property of Bharat Heavy Electrical Limited. It must not be used directly or indirectly in any way detrimental to the interest of the company.

स्वाधिकार एवं गोपनीय
 इस प्रलेख में दी गई सूचना भारत हेवी इलेक्ट्रिकल्स की सम्पत्ति है इसका प्रत्यक्ष एवं अप्रत्यक्ष रूप से किसी भी तरह प्रयोग, जो कि कंपनी के हित में हानिकारक हो न किया जाए।

करताक्षर एवं दिनांक SIGN & DATE	 11/2/18	
---------------------------------	---	--

सामग्री सूची संख्या INVENTORY NO.	REV.NO.		निर्माणकर्ता WORKED BY	TARUN BANSAL	SD/-	
P-5718	10		जांचकर्ता CHECKED BY	ROHIT BANSAL	SD/-	

**AIR EXHAUSTERS TO BE SUPPLIED IN PAIRS
 AS PER ORIENTATION* BELOW**

* Air Exhausters suitable for flexible orientation (in addition to mirror-image orientation) shall be preferred. This can be achieved if the design permits rotation of air outlet connection together with casing by 180°, keeping the bed plate position unchanged.

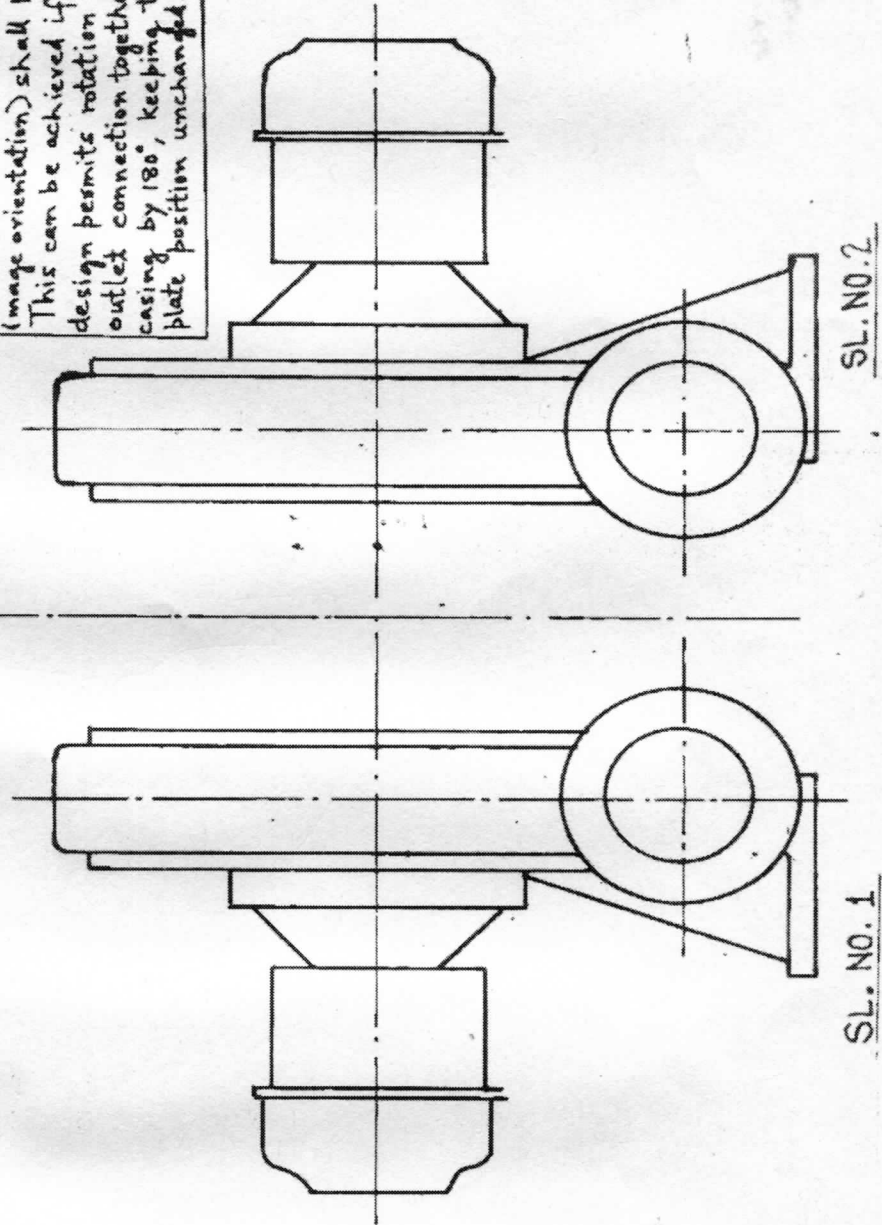

FIG-2

सामग्री सूची संख्या को अधिकृत किए गए	SUPERSEDES INVENTORY NO.	DATA SHEET
--------------------------------------	--------------------------	-------------------



A. FAN

1. Name of manufacturer
2. Model No.
3. Position
4. Flow dry air M³ / sec
5. Pressure difference k p a
6. Flow steam mixture m³ / sec
7. Mixture temp
8. Pressure difference k p a (with air steam mixture)
9. Density of mixture kg / m³
10. Density of medium during test kg / m³
11. Power absorbed K W
12. Speed RIM
13. Weight of rotating part kg
14. Weight of fan exhauster kg
15. Moment of inertia kg m²
16. Standard and degree of rotor balancing
17. Static or Total Efficiency

B. MOTOR:



1. Model No.
2. Rating K W
3. Rated voltage
4. Frequency 50 Hz
5. Speed R P M
6. Degree of protection
7. Rated current amp

करताक्षर एवं दिनांक SIGN & DATE		
---------------------------------	--	--

सामग्री सूची संख्या INVENTORY NO.	REV.NO.		निर्माणकर्ता WORKED BY	TARUN BANSAL	SD/-	
P-5218	10		जांचकर्ता CHECKED BY	ROHIT BANSAL	SD/-	

COPYRIGHT AND CONFIDENTIAL
 The information on this documents is the property of Bharat Heavy Electrical Limited. It must not be used directly or indirectly in any way detrimental to the interest of the company

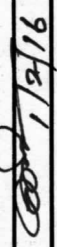
स्वत्वाधिकार एवं गोपनीय
 इस पत्रलेख में दी गई सूचना भारत हेवी इलेक्ट्रिकल्स की सम्पत्ति है इसका प्रत्यक्ष एवं अप्रत्यक्ष रूप से किसी भी तरह प्रयोग, जो कि कंपनी के हित में हानिकारक हो न किया जाए।

दिनांक एवं हस्ताक्षर SIGN & DATE		उत्पाद मानक (डीप - हरिद्वार)		HE 57008			
		PRODUCT STANDARD (HEEP - HARIDWAR)		पृष्ठ Page	का of		
समिती सूची संख्या को अधिकारिता कायदा	SUPERSEDES INVENTORY NO.	8. Power factor 9. Starting current Amp 10. Temp. Rise over 50 °C ambient, °C 11. Class of insulation 12. Rated torque - NM 13. Starting torque -NM 14. Weight of rotating part, Kg 15. Weight of motor - Kg 16. Moment of inertia K g-m ² . 17. Efficiency Class of motor C. ASSEMBLY: 1. Weight, Kg 2. Foundation bolts & nut – Yes 3. Drawing No.					
COPYRIGHT AND CONFIDENTIAL The information on this documents is the property of Bharat Heavy Electrical Limited. It must not be used directly or indirectly in any way detrimental to the interest of the company							
स्वत्वाधिकार एवं गोपनीय इस प्रलेख में की गई सूचना भारत हेवी इलेक्ट्रिकल्स की सम्पत्ति है इसका प्रलेख एवं अप्रत्यक्ष रूप से किसी भी तरह प्रयोग, जो कि कंपनी के हित में हानिकारक हो न किया जाए।							
कस्ताक्षर एवं दिनांक SIGN & DATE							
समिती सूची संख्या INVENTORY NO.	REV.NO.			निर्माणकर्ता WORKED BY	TARUN BANSAL	SD/-	
25718	10			जांचकर्ता CHECKED BY	ROHIT BANSAL	SD/-	