

OPEN TENDER CHECKLIST

Sl. No.	Document Name	Vendor Confirmation (Signed copy to be submitted along with Techno Commercial Offer)
01	Annexure A	Submitted <input type="checkbox"/> Not Submitted <input type="checkbox"/>
02	Annexure B	Submitted <input type="checkbox"/> Not Submitted <input type="checkbox"/>
03	Annexure C	Submitted <input type="checkbox"/> Not Submitted <input type="checkbox"/>
04	CEBG	Submitted <input type="checkbox"/> Not Submitted <input type="checkbox"/>
05	BHEL's TDC	Submitted <input type="checkbox"/> Not Submitted <input type="checkbox"/>
06	Online SRF (Original to be sent thru' courier)	Submitted <input type="checkbox"/> Not Submitted <input type="checkbox"/>

BHEL :: BAP :: RANIPET

PURCHASE DEPARTMENT

Page No: 01/01

NOTICE INVITING TENDER

ANNEXURE-A TO OPEN TENDER 5551422E / 29.02.2016

LAST DATE FOR SUBMISSION OF BID: 07.04.2016 BEFORE 14:00 HRS IST

BID OPENING DATE: 07.04.2016 AT 14:30 HRS IST

SCOPE : SUPPLY OF FORGED & PROOF MACHINED COMPONENTS AS DETAILED BELOW:

SNO	DESCRIPTION	DRAWING	SUPPLY CONDN	MATERIAL SPECIFICATION	APPLICABLE BHEL TDC	UNIT	QTY	DELIVERY PERIOD
01	CIRCULAR PLATE SIZE: 280 x DIA 2100	NA	FORGED AND PROOF MACHINED	AISI 1020	RTA : 403/01	NO	4.00	60 DAYS FROM PO
02	SHAFT	DRG 3-55-227-01857	FORGED AND PROOF MACHINED	42 CRMO4V+QT	RTF : 309 / 03	NO	8.00	60 DAYS FROM PO
03	SHAFT	DRG 4-55215-02685	FORGED AND PROOF MACHINED	42 CRMO4V+QT	RTF : 309 /03	NO	6.00	60 DAYS FROM PO
04	COUNTER WEIGHT	DRG 3-55-228-01655	FORGED AND PROOF MACHINED	P 355 NH	RTF : 307 / REV 05	NO	192.00	60 DAYS FROM PO
05	COUNTER WEIGHT	DRG :3-55-228-02165	FORGED AND PROOF MACHINED	P 355 NH	RTF : 307 / REV05	NO	120.00	60 DAYS FROM PO
6	WELD IN HUB SIZE: 580 X 265 X 255	DRG : 4-55-228-03058	FORGED AND PROOF MACHINED	P 500 NH	RTF : 307 / REV05	NO	6.00	60 DAYS FROM PO
07	SUPPORT RING SIZE: 1017 X 920 X 280	DRG : 4-55-228-03062	FORGED AND PROOF MACHINED	P 355 NH	RTF : 307 / REV05	NO	6.00	60 DAYS FROM PO
08	LOAD RING SIZE: 1606 X 1355 X 280	DRG : 4-55228-03060	FORGED AND PROOF MACHINED	P 500 NH	RTF : 307 / REV05	NO	6.00	60 DAYS FROM PO

Note:

1. Quantity Tolerance: Not Applicable.

2. Pointwise specific confirmation to BHEL TDC to be given in the Techno-Commercial Bid without fail.

3. In case of supplies from any new foreign suppliers, who are not in BHEL Product Material Directory, material inspection shall be carried out by Third Party Inspection Agency like Lloyds or SGS or BVQI prior to shipment at Supplier's work and total inspection charges shall be borne by the supplier only. (Quoted price shall be inclusive of TP inspection charges)

4. In case of offer with equivalent material grade, then copy of the entire specification of that equivalent grade shall be sent along with the techno-commercial bid without fail.

5. In case of late offer, the same will be returned to the supplier without opening

Sr. Manager / Purchase



ANNEXURE –B

ENQUIRY: 5551422E / 29.02.2016

TENDER DUE DATE: 07.04.2016 @ 1400 HRS

SUPPLY OF FORGED & PROOF MACHINED COMPONENTS
(CIRCULAR PLATE, SHAFT, COUNTER WEIGHT, WELD IN HUB,
LOAD RING AND SUPPORT RING)

GENERAL TERMS & CONDITIONS
(FOR GUIDANCE TO THE SUPPLIERS)

A] Submission of Offer

a) Invitation for bid

Tenders are invited through electronic mode from eligible suppliers in case of open tenders and from suppliers to whom the enquiry is addressed in case of Limited / Single Tender.

The offers shall be posted into the system before the date and time specified in the tender.

The offer shall be sent on single part / two part / three part basis as specified in the main tender document.

Bids shall be submitted through e-Procurement portal, <https://bheleps.buyjunction.in>, of M/s mJunction Services Limited who are our solution provider.

b) Hardware and Software requirements for participating in e-tender

Requirement for participating in e-Procurement is as under:

- i) A Computer with internet connectivity (Internet Explorer Version 7 and above.
- ii) Digital Signature Certificate (Class 3- SHA2-2048 BIT- with both Signing and Encryption component separately).
- iii) JAVA (Version 1.8 Update 45).

c) Instructions for Registered Suppliers

For all types of tenders (Single / Limited / Open) an automated email alert regarding issue of the Tender will be sent by the e-procurement portal to all Suppliers registered with BHEL, Ranipet for the item/s for which the tender is issued.

In case of open tenders, Registered suppliers with registered DSC will have to login with their user id/password & DSC and search for the Open Tender. On clicking the “Interest” button, they will get attached to that particular Open Tender.

Registered suppliers without DSC will have to first register themselves in <https://bheleps.buyjunction.in> as new supplier by clicking the “New Supplier” button.

To know the procedure for obtaining Digital Signature Certificate (DSC), suppliers who are not having the DSC are advised to visit our website www.bhel.com → Tender Notifications → Sample Checklist.

d) Instructions for new suppliers wishing to bid against open tenders

New, unregistered suppliers wanting to bid against open tender/s will have to first register themselves in <https://bheleps.buyjunction.in> as new supplier by clicking the “New Supplier” button.



After entering the Income Tax Permanent Account Number (PAN) details and pressing “Enter”, they have to click the “Interested” button against the respective BHEL Unit for which they want to participate in the Open Tender and also fill up other relevant Company information as a one-time activity.

Then, a box for filling in a “preferred login id” will appear at the top of the page. After giving the “preferred login id” and then clicking the “Next” button, Supplier would have to map their DSC (which will be activated by M/s mJunction Services Limited), if available. Or else, by pressing “skip” button and selecting relevant procurement category from the list available in the next page and “agreeing” to the BHEL’s terms & conditions, user id and password will be generated/activated once in 2 hours and mailed to their registered email id. Using this user id and password, Supplier has to login and map the Digital Signature Certificate they have purchased to their code. The DSC will then be activated by M/s mJunction Services Limited.

As required by the tender, the necessary documents have to be filled-in online, in the provided template. Additional documents required are to be scanned and uploaded as .pdf file. Suppliers are advised to take note that the maximum space that is provided for uploading the documents that are to be attached is 300 MB. However the size of an individual document cannot exceed 10 MB. For any clarification on submission of offer on line, attention of the Supplier/s is invited to our document “Supplier Manual” hosted in the home-page of the e-procurement portal. During normal business hours, helpline maintained by the service provider mJunction is available for clarifying any doubts of supplier/s. The helpline numbers are 09840704941 or 09500199108.

Typical documents that would be required as part of tender submission would be

- a) **Complete technical Offer** with details, catalogues, as applicable.
- b) **Un-priced bid** (i.e. Bid without the Price) as per given format, if any.
- c) **Filled-in BHEL’s Standard Terms & Conditions** as per Annexure enclosed with the Tender Document,
- d) **Deviation summary** submitted in two parts – giving the summary of technical deviations separately and the commercial deviations separately, if any and
- f) **Supporting documents** to substantiate equivalent material specifications / sections, where quoted for.
- g) Where asked for, **Client list** with their full address including detail of contact person with phone no., fax no. & e-mail ID (if any) to whom the same / similar items are supplied in the past two years. The date of supply may also be indicated, against each client.
- h) **Bidders who are not already registered with BHEL Ranipet** are requested to submit the Supplier Registration Form (SRF) online and a hard-copy of the same has to be sent addressed to the tender issuing authority for evaluating and registering as an approved vendor. The Supplier Development Cell (SDC) of BHEL, Ranipet would process the SRF for evaluation / registering the Supplier.

Suppliers can also upload their credentials by way of submission of Performance certificate/s issued by their customer/s detailing the quantity supplied and specification along with the un-priced PO copies and proof of supply along with the offer.

Technical acceptance of offer by BHEL shall be based on the evaluation of offer and the submitted documents.

Note

- (i) The materials offered, shall conform to the specification and scope attached in the tender.



(ii) In case the offered materials are not conforming to the Enquiry material Specification, such offers would not be considered for evaluation and would be rejected.

Where equivalent specifications are offered, considering such offers will be at the sole discretion of BHEL. Wherever alternative standards / specifications are offered by Bidder, the Bidder shall provide sufficient documentary evidence to ensure equivalence to the designated standards / specifications, failing which the offer would be considered as not technically acceptable and hence shall stand rejected.

(iii) All taxes and duties payable as extra to the quoted price should be specifically stated in offers (as appearing in the online template).

Offer/s from within India shall be submitted along with CST & TIN No. / Tariff No. etc, failing which the purchaser will not be liable for payment of such taxes and duties. Our TIN No. 33024364741, CST No. 1141686/01.07.2014, BHEL ECC No. AAACB4146PXM008.

(iv) The un-priced bid shall be used to indicate relevant commercial terms such as scope of freight and insurance, applicability of duties and taxes etc. All Commercial terms are to be indicated clearly in the offer.

(vi) No changes shall be entertained once the bid is opened unless otherwise specifically agreed to in writing by BHEL.

(vii) Money values other than for those items appearing in the un-priced bid template shall not be indicated anywhere in the un-priced bid.

(viii) Time required for inspection (at Supplier's works), should be clearly given in terms of numbers of working days.

(x) **Offers sent by FAX / E-mail:** would not be entertained.

Price Bid in conformance with the specification and terms as given in the Un-Priced bid document.

Caution:

The suppliers are severely cautioned to note that the price bid document accepts the price in figures only. It does not allow the supplier to write the value by words. Therefore all care shall be exercised by the supplier while filling in the figures. Once the price bid is opened no option is available for the supplier to retract the offer under any grounds. If a supplier, for any reason whatsoever approaches BHEL with a request for change in the price, it would be treated as going back on the offer submitted. In such cases, action would be initiated by BHEL for suspending further business dealings with such suppliers as per policy of BHEL which prevails at that point of time.

Foreign / Overseas suppliers are hereby informed that offers with differential currencies are not permitted for a given tender document.

Note

(i) The price break-up should be in line with technical specification / scope of the tender. (Cost of material, packing charges, forwarding charges, freight and insurance charges shall be shown appropriately, as applicable).

(ii) Unless otherwise specified as a part of the tender condition, No Price Variation Clause will be entertained and No advance payment will be made by BHEL.



(iii) In case, there is a discrepancy in the term quoted in techno-commercial bid and price bid, the term as per the techno-commercial bid (Part I) shall hold good and the commercial term quoted in the Price Bid (Part II) shall not be considered.

(iv) In their own interest, all Tenderers are advised to double check their prices, applicable duties and taxes.

(v) The quotation should be valid at least for a period of 90 days from the tender opening date.

(vi) Indian bidders should submit the prices in Indian Rupees only.

(vii) Foreign bidders may submit their bid in foreign currency. The currency for quoting shall be selected from the drop-down menu provided.

(x) Indian Suppliers shall quote on FOR Destination basis only. Destination is BHEL, Ranipet Stores or BHEL Project Site as specified in the tender requirement. Foreign Suppliers shall quote on CFR Chennai Seaport Delivery and Insurance will be in BHEL's scope. No other delivery terms shall be acceptable. Shipment shall be arranged by the Seller on *Liner in / Liner out basis*. As per Government of India guidelines, BHEL Ranipet being a Government of India Undertaking the Bill of Lading shall be made with the Shipper as "Government of India". This shall be specifically confirmed by the Bidder.

(xi) Where the cargo is containerized, Container washing charges, stuffing charges and / or any other such charges would be to the account of the supplier, where the containers are to be stuffed at the works of the supplier.

B] Opening of Offers

a) **Tenders can be submitted up to 1400 Hours on tender opening due date. Part I will be opened on the same day at 1430 Hours. Results of the tender opening will be available for viewing for upto 7 days from the date of opening.**

b) Price Bid opening will be done through e-mode / Reverse Auction method (English method) **which will be decided after techno-commercial bid evaluation is completed.** All tenderers would have to specifically give their acceptance for this in their bid/s.

Note

(i) Bids including all enclosures and supporting documents like catalogues, pamphlets, etc., shall be provided in ENGLISH language only.

(ii) At its option, BHEL may consider extending the due date/s for the tender openings. Sufficient notice would be given by BHEL for such extensions.

(iii) Deviations shall be summarized and provided in a "Deviation Statement", listing the points and the deviation against each point.

(iv) BHEL reserves the right to increase or decrease the tendered quantity and to order on more than one vendor at the lowest acceptable price to BHEL. In ordering on more than one source, the ratio of quantity split will be as specified in the tender terms.

If not explicitly specified, BHEL reserves the right to split the quantity of the enquiry as follows: 70% quantity being ordered on the original lowest bidder (L1) and balance 30% on the next higher bidder/s excluding H1, who accepts the L1 price. However, the final decision to split the order rests with BHEL only.



In the event that the other than L1 suppliers do not accept the L1 price, then the balance will be reverted to the original L1 and the original L1 shall be bound to accept the balance of the enquiry quantity kept reserved for order splitting. This decision would be given by BHEL within 60 days of the price bid opening.

(v) Offers for part quantities on item level basis are not acceptable to BHEL. While tenderers can quote for some or all the tendered items, no supplier shall quote for partial quantity of any given enquiry item. Such partial offer would not be considered in the enquiry for that item. Suppliers are to note that the evaluation unless otherwise specified will be on item level and not for the tendered items as a whole.

C] Evaluation of Offers

a) The price bids including the impact price (if any) of the technically acceptable offers alone shall be opened.

b) Offers with pre-conditions (like conditional discounts) for price are liable to be not considered / rejected. For evaluation such conditions would be removed and only the base offer would be considered for evaluation and comparison.

d) In the event of any change in scope / quantity arising out of the discussions, offerers would be given a chance to submit their revised offer / impact bids. The option for the revised offer / impact offer will be triggered by BHEL. The Supplier then will have the facility to feed-in the revised price / impact price as per the provision given by BHEL. The impact price can be positive or negative (or nil). The impact price option shall contain only the price addition / deletion for such change in the scope / quantities, over and above the original scope and price quoted. The original price quoted would remain unchanged. The total price would then be computed by the arithmetic addition of the original price and the impact price. Where BHEL gives the option of submitting the revised offer, the impact would be computed as the arithmetic difference of the revised price and the original price.

e) For evaluating the overseas offers, CFR Chennai Sea Port price quoted will be taken into account. The cost to BHEL will be arrived at by loading the applicable customs duty project wise, insurance charges, inland transportation charges to BHEL stores and LC charges etc.,

f) For suppliers within Tamil Nadu state, as per prevailing VAT Act, VAT input credit is currently 5%.

g) BHEL reserves the right to reject without assigning any reasons / load any offer with factors other than already specified for such offers having deviations to BHEL Specifications, Standard Terms & Conditions at its discretion. The decision of BHEL in this regard shall be final.

h) BHEL reserves the right to reject an offer due to unsatisfactory past performance during tender finalisation / execution of a contract at any of BHEL projects / units or if unsatisfactory performance report is received from the party/s referenced by the supplier at any time during tender finalisation.

i) BHEL reserves the right to operate Purchase / Price preference to Government of India Undertakings, which shall be given as per the guidelines of Government of India given from time to time and / or relax the Terms and Conditions of the tender.

j) For the purpose of comparing prices, tender prices shall be converted to Indian rupees and the conversion shall be made by using the TT Selling rate of State Bank of India (SBI) prevailing on the date of opening of Techno-Commercial / Unpriced bids. If the relevant day happens to be a bank holiday, then the forex rate as on the previous bank (SBI) working day shall be taken. This exchange rate will be followed till placement of order. Tenderers may please note that even if an impact price is taken as in (d) for purpose of price evaluation and arriving at the rank; the exchange rate will be taken as explained above.



k) Unless otherwise specified, evaluation will be on individual line item basis only and ordering will be on respective L1 vendors.

l) BHEL reserves the right to conduct negotiations on the “Price” and “Other Commercial Terms and Conditions” with the lowest ranked offerer at any time after the bid opening but before the release of the Purchase Order and If so required by BHEL, Supplier may have to share their costing sheet with BHEL.

D] Execution of the Order

a) BHEL will have the option to pre-inspect the materials at Supplier's works by BHEL's own inspector or by third party agency appointed by BHEL or BHEL's end customer/s. The mere act of the pre-dispatch inspection (PDI) does not absolve the Supplier from giving the specifications as agreed upon in the Purchase Order. In the case of inspection being carried out by a third party inspector (TPI) as per the extant practice, the TPI would forward the Inspection Report (IR) along with Test Certificates and other related documents to the Quality Assurance (QA) Department of BHEL. The QA department after scrutinising the report/s submitted by the TPI would issue the Material Dispatch Clearance Certificate (MDCC). Suppliers are hereby informed that materials should be dispatched only after getting the MDCC, failing which the materials may be rejected on receipt at BHEL Stores.

b) In the case of overseas suppliers Inspection call for carrying out the inspection shall be given 30 days before the scheduled contract delivery date. The Inspection date/s given by the Supplier shall be on firm basis. For local Suppliers the Notice period of Inspection shall be 10 working days.

c) Deviations, if any pointed out by the visiting Inspection team of BHEL shall be corrected and the items as per specification shall be dispatched on or before the contract delivery date after getting the MDCC.

d) The final inspection for acceptance will, however be carried out at BHEL's works at Ranipet.

e) The contract delivery date is the date of receipt at BHEL Stores for suppliers in India, applicable in the case of FOR Destination Contracts.

For ex-works contracts or FOR dispatching station indigenous contracts, the date of the Lorry way bill issued by the authorised transport carriers of BHEL / Railway Receipt / Courier Way bill / Airway bill or any such dispatch documents of carriage approved by BHEL would be considered as the Contract Delivery Date. In the case of CFR contracts with overseas suppliers, the B/L date shall be taken as the Contract Delivery Date

f) Travel & other local stay cost for the Inspectors sent by BHEL will be to BHEL account, but other Inspection Charges, if any shall be to the account of the Seller only.

g) The supplier shall arrange for packing suitably in all respects for normal transport by sea / rail / road and Materials shall be suitably protected against effect of tropical salt laden atmosphere in the event of shipment being delayed at ports / store yards and as per BHEL TDC.

h) Foreign suppliers shall dispatch on CFR agreed Sea-Port basis, according to the contract conditions. Indian suppliers shall dispatch on free delivery (door-delivery) at BHEL stores basis only. Unloading the materials at BHEL Stores would be to the account of BHEL only.

i) In the event of any short supply, it shall be the responsibility of the supplier to deliver such short supplied/ missing items on Free-of-Cost basis at BHEL stores, including customs clearances at Indian Ports in the case of foreign suppliers.

k) Terms of payment:



k.1) For Indigenous Suppliers: Unless otherwise agreed to by BHEL, the standard payment terms of BHEL shall be: For non-MSE suppliers 100% payment made directly through EFT within 90 days from the date of receipt and acceptance of materials at BHEL Stores, Ranipet or 90 days from the date of acknowledgement of receipt of materials at destination specified. If any supplier asks for payment terms other than the above specified, then suitable loading on cost will be considered. **Loading of any deviation in the payment terms w.r.t tender terms will be “Base rate of State Bank of India (SBI) (as applicable on the date of bid opening: Techno-commercial bid opening in case of two part bids) + 6%, will be considered for loading for the periods of relaxation sought by bidders.**

k.2) For MSE vendors (under Micro & Small category alone) 100% payment will be made within 45 days from the date of receipt and acceptance of materials at BHEL Stores, Ranipet or 45 days from the date of acknowledgement of receipt of materials at destination specified.

i.c) NOTE:

Where the destination specified is other than BHEL Stores Ranipet, for claiming payment, Supplier has to submit proof of receipt of the materials at the destination by furnishing a copy of the acknowledged despatch document (LR/RR/Courier receipt etc.) .

If the Bidder is bidding for the first time and wants to be considered as an MSE then, the Bidder shall submit document evidencing that they are an MSE along with a certificate from a Chartered Accountant certifying the status of their Unit / Works clearly specifying the address of the works which is to be considered as MSE and send the same to BHEL, Ranipet either before the tender opening date or upload it as a part of the tender document in the e-procurement portal. Where the document is submitted electronically a hard copy shall invariably be sent within a reasonable period (not exceeding 30 days) from the bid opening date for the purpose of BHEL's records. If the hard copy is not received within this specified time, then the supplier would be treated as a non-MSE. BHEL will not be responsible for any postal / courier / delivery delays.

For approved vendors the status as on the date of the bid opening as available with BHEL Ranipet's records shall be used for reckoning the status of the Bidder as an MSE or otherwise.

Offer/s received without these documents will be treated as non-MSE and order finalization will be done based on this premise. Documents submitted after Bid-opening will not be considered in this tender. This provision for MSE will apply subject to the condition that the participating MSE meets the tender requirements.

For approved suppliers, in case of any change in the MSE status, it shall be the responsibility of the Bidder to notify the change as a part of the Bid document. If at a later date it comes to the knowledge of BHEL, Ranipet that the change in the status has not been intimated by the Bidder and the order is obtained under the premise of an MSE then BHEL would cancel the pending order against this tender and take necessary steps for suspension of the business dealing with the Bidder as per the procurement policy of BHEL. Similarly if a supplier claims MSE status after the Part I bid opening, then the same would not be considered in the tender.

In case after the bid opening it is seen that no MSE has become L1, then depending on the nature of the item, if it is not possible to split the tendered items / quantities on account of reasons like customer contract requirements of supplying one make for a given project or technical reasons like the tendered item being a system etc. then BHEL would not counter offer the L1 prices even though there may be MSE bidders within the +15% band of L1.

Other concessions for MSEs / Reserved sectors

In addition to the concessions specified above, MSE suppliers will be eligible for such other concessions as per the MSME Act 2006 and any other benefits / concessions that may be announced by the Government of India from time to time.. However, such concessions as applicable at the time of tender opening alone will be applicable. Any concessions advised after tender opening will not be considered for the current tender.



Items that are reserved for MSE and for any other items for which reservations for Indian manufacturers are notified by the Govt. Of India, such concessions as prevailing on the date of tender opening shall apply as a part of this tender conditions.

ii) Foreign Suppliers “100% thru’ irrevocable & unconfirmed LC at sight within 3 weeks from the PO date through any one of our Bankers listed elsewhere in the tender conditions for 100% value (less Agency Commission, if any) valid up to the PO delivery period and 15 days thereafter for negotiation. All bank charges in India to BHEL's account and all other charges outside India to Supplier's account. **BHEL reserves the right to load the price of foreign suppliers in order to bring them on common platform as per Indigenous Suppliers on the account of differential payment terms to Indigenous Suppliers. Loading of payment terms will be “Base rate of State Bank of India (SBI) (as applicable on the date of bid opening: Techno-commercial bid opening in case of two part bids) + 6%, will be considered for loading for the periods of relaxation compared to indigenous suppliers i.e. 90 days.**

m) Any incidence of tax like Income tax, Service Tax and Withholding any other similar tax / duties /levies imposed by the Government of India, or the State Government, where the BHEL Unit is located, deductible at Source, during the tenure of the Order shall be deducted by BHEL and necessary certification of the deduction (Tax deduction at Source) would be given. This is subject to the supplier fulfilling the necessary documentation as specified by the Government of India. (e.g. Tax Residency Certificate, PAN Number etc.)

n) The Guarantee period shall start from the “Date of receipt and acceptance of the materials at BHEL Stores.”

E) Liquidated Damages Clause:

BHEL will levy penalty as Liquidated Damages (LD), for delay in delivery. The damages shall be at the rate of ½% per week or part thereof subject to a maximum of **10%**. The contract delivery date for purpose of L.D is the date of receipt at BHEL Stores for suppliers in India for F.O.R. Destination Contract and the date of dispatch clearance given by BHEL for overseas suppliers. For ex-works or F.O.R dispatching station contracts, the date of the dispatch document will be reckoned as the date of delivery for computing the LD. Supplier shall deduct the applicable LD from the first payment when raising the claim for the same. The applicable LD if any would be communicated by BHEL along with the dispatch clearance. It is taken by BHEL that Foreign Suppliers have confirmed their acceptance to BHEL for opening the LC for value which is the value of the order reduced by the applicable LD. The LD would apply on the undelivered portion only. In case of reasons attributable to BHEL for the delay in delivery (for e.g. delay in arranging the pre-inspection) then the delivery time would be reset to the extent of the time delay attributable to BHEL, with waiver of the LD. Delivery being the essence of BHEL’s contract requirements, Unless otherwise specified the LD would apply on the undelivered portion of the contracted items. In the event that a **Supplier does not accept the LD condition above, the offer would be loaded to the extent of the shortfall with respect to upper limit specified above.**

F) Miscellaneous

i) Role of Agents:

BHEL will deal directly with indigenous manufacturers only.

BHEL strongly discourages the engagement of Agents in India by foreign principals, to deal with BHEL, in BHEL’s tenders.

BHEL will not enter into any correspondence with an Indian Agent.

The Indian Agent will not be extended the privilege given to the principals, such as that of attending the tender openings, attending technical discussions, commercial discussions or price negotiations and such like.



In case, in spite of the above, a foreign principal insists on engaging an Indian Agent, It is made clear by BHEL that:

It is the sole responsibility of the foreign principal to ensure the Agent does not represent any other foreign principal in a given tender.

An undertaking to this effect shall be given by the foreign principal that his / her Agent does not represent any other foreign principal in the tender. This document shall form a part of the techno-commercial offer.

If at any stage of the tender, BHEL finds that an Indian Agent has represented more than one foreign principal, all such offers of and all the foreign principals would be disqualified summarily in the tender inquiry.

BHEL will only give an intimation of notice of the disqualification. No correspondence would be entertained by BHEL, on their decision. Such decision of BHEL shall be irrevocable, firm and final and shall be binding on the tenderer.

BHEL, due to business reasons would ban, would have banned Indian agents from dealing with BHEL.

Any foreign principal who engages such a banned agent, or an employee of the banned agency, or any other person connected with the banned agency, at any time during the tender proceedings, would be disqualified from the tender proceedings. The decision of BHEL in this regard shall be final and be binding on the OEM.

Hence in their own interests, prospective tenderers may check with BHEL, the status of their proposed agent vis-à-vis BHEL.

In view of the requirement of BHEL, it is strongly suggested that in their own interest, foreign principals may desist from engaging any Indian agent and deal with BHEL directly and it is stressed that any Main producer proposing to deal with BHEL by engaging and through an Indian Agent does so at their own risk.

BHEL shall in no way be responsible for any consequences that may arise to the foreign principal on account of the antecedents / actions of their Indian Agent.

In the event of the foreign principal engaging an Indian Agent:

a) **The Supplier shall furnish an authenticated copy of the Agency Agreement with his agent detailing the precise relationship between them and their mutual interest in the business along with techno-commercial bid.**

b) The Supplier shall furnish original authorization letter for the Indian Agent. The letter shall contain name, contact person, complete postal address including phone, fax and e-mail ID. It shall also spell out the type of services to be rendered by Indian Agent.

c) Indian Agent & Agency commission: An Indian Agent can represent only one Foreign Manufacturer against a particular Tender. The FOB price quoted by the foreign bidder shall include the agency commission. However, the agency commission component payable to their Indian Agents shall be shown separately in the Offer, either as a lump-sum or as a percentage of the quoted price. This will be paid by BHEL in Indian Rupees, on satisfactory receipt & acceptance of the materials. For calculation of Rupee equivalent of Agency Commission, exchange rate as prevailing on the date of Purchase Order will be taken and

d) For all discussions, technical clarification and negotiations etc. only the principal would be authorized for interaction with BHEL. The Agent shall not be a party to the discussions / negotiations and would not be normally allowed to participate.

ii) Terms & Conditions of Letter of Credit (L/C) for overseas suppliers (indicated for acceptance).

a) Unconfirmed irrevocable Letter of Credit at Sight only will be opened by BHEL. Confirmation of L/C is not preferred by BHEL. Also L.C will be opened in Lots in line with the staggered delivery.

b) All Bank charges out side India are to the Supplier's account and within India to BHEL's account.

c) In case of L/C extension caused by delays attributable to the Supplier, the L/C extension / commitment charges are to be borne by the Supplier.

iii) Other terms & conditions for letter of credit: - Documents for negotiation

a) Signed Commercial invoice in quadruplicate, for a value not exceeding the draft amount, quoting the import Licence No and certifying goods evidencing shipment of the merchandise are as per Applicant's



Purchase Order. The amount of invoice after deducting Indian Agent's commission, if any, should not exceed the Credit amount. (The Indian agent's commission, if any, is payable in India in Indian rupees only.)

- b) Certificate of Country of Origin, from the country of manufacture, issued by the Chamber of Commerce.
- c) One set of Original and two sets of Non-negotiable copies of 'signed', 'unmarked', 'clean on board' Ocean Bill of Lading, showing Shipper as "Government of India" Account M/s. Bharat Heavy Electrical Ltd, Unit: BHEL, Ranipet as consignee (The opening bank should not be notified as consignee), marked freight payable / prepaid at destination.
- d) Packing list in 4 copies in English, indicating Size wise Number of bundles / pieces shipped and weight.
- e) Certified copy of the fax / e-mail sent by the beneficiary to the applicant giving the following particulars of shipment, as the insurance is to be arranged by the Applicant in India: (a) Purchase Order Number & date; (b) Bill of Lading Number & date (c) Name of vessel; (d) Port of Loading; (e) Number of bundles / pieces and weight; (f) Invoice Number, date and value (g) Purchase Order item number's despatched. The cable / fax is to be sent within 2 working days of shipment.
- f) Beneficiary's certificate showing the relevant airmail / courier reference no. and date that the following clauses have been complied with:
 - 1] Beneficiary to forward by Registered Airmail / Courier one complete set of original documents and one set of non-negotiable documents within 3 working days of obtaining shipping documents to Regional Manager (ROD), Bharat Heavy Electricals Ltd, No. 165, Thambu-Chetty Street, Chennai – 600 001. India. (Phone: +91-44-25341249, 25341240 / Fax - +91-44-25340787; e-mail: raja@rodchn.bhel.co.in)
 - 2] Beneficiary to courier at his cost 3 copies of complete set of non-negotiable documents to the Officer who released the Purchase Order.
 - 3] Declaration by the Supplier certifying that the contents in each case are not less than those entered in the invoices / packing list and that the invoicing for the supplies effected is strictly in accordance with agreed rates as stipulated in the Purchase Order.
 - 4] Declaration to the effect that all other documents as per purchase order has been couriered to the Purchase order releasing authority
 - 5) The carrying steamer should be seaworthy, less than 25 years of age and approved by Lloyds / Classification Societies / General Insurance Corporation of India from time to time and
 - 6) Copy of Dispatch Clearance / Instruction issued by BHEL.

iv) Documents to be sent directly to the Purchaser prior to shipment

- a) Manufacturer's Original Internal Inspection / Test certificate in triplicate.
- b) Manufacturer's Original Guarantee certificate as per Purchase Order. The material shall be guaranteed for a period of 12 months from the date of acceptance of the materials at BHEL stores or 18 months from the date of dispatch whichever is earlier. The acceptance would be evidenced by the Stores Receipt Voucher (SRV) which will be raised by BHEL.
- c) Inspection / Test Certificate issued by BHEL / Inspection agency specified in the Purchase Order. In the event that Inspection prior to dispatch is not carried out by the Engineers of BHEL, the Inspection certificate of the third party so authorized by BHEL and
- d) Any other documentation as specified in the Purchase Order.



v) Conditions for transportation:

- a) All shipping documents shall show the Purchase Order Number & Date, Import Licence Number & Date, and Letter of Credit Number & Date.
- b) Transshipment is to be avoided.
- c) Loading on deck is not permitted. The transport document must not contain a provision that goods may be carried on deck.
- d) A transport document which is produced or appearing to have been produced by reprographic, automated or computerized systems or as carbon copy will be accepted as an original document provided that it is marked as original and is ink-signed.
- e) The transport document must contain all the conditions of carriage on the original document.
- f) The transport document must not indicate the place of destination as being different from the port of discharge.
- g) The transport document must not contain the indication 'intended' or similar qualification in relation to the vessel or other means of transport or port of loading or port of discharge.
- h) The transport document must be issued by the carrier or his agent and not by any freight forwarder.
- i) Transport documents bearing reference by stamp or otherwise, to costs additional to the freight charges are not acceptable.
- j) The Bills of Exchange must be dated and presentation of documents for negotiation must not be later than 15 days after the date of shipment and in any case not later than the expiry date of the Credit.
- l) Indian suppliers shall dispatch the materials on freight prepaid and on door-delivery basis (FOR Destination – Destination: BHEL Stores) and
- m) In the event there is a delay by the Supplier in negotiating / submitting the document, any demurrage / wharfage arising out of the same shall be to the account of the Supplier and shall be deducted from the final payment. Also, in such cases, the Supplier shall authorize the Steamer / Shipping agent / transporter to freely release the consignment to BHEL by providing a “Surrender Bill of Lading”. Over-seas Suppliers have to give a No-Objection Certificate to BHEL, authorizing BHEL to get the Delivery Order from the Steamer Agent without producing the Original Bill of Lading. This is required to ensure avoidance of incidence of demurrage at Chennai Sea-port that may arise in case of delayed presentation of documents by the Seller.

G) Reverse auction (RA) / on-line bidding on internet:

Against this enquiry for the subject item/ system with detailed scope of supply as per enquiry specifications, BHEL may resort to “REVERSE AUCTION PROCEDURE” i.e., ON LINE BIDDING (THROUGH A SERVICE PROVIDER). The philosophy followed for reverse auction shall be English Reverse (No ties).

1. For the proposed reverse auction, technically and commercially acceptable bidders only shall be eligible to participate.
- 2.a. BHEL reserves the right to go for Reverse Auction (RA) instead of opening Part I bid, submitted by the bidder. This will be decided after techno-commercial evaluation. All bidders to give their acceptance for participation in RA. Non-acceptance to participate in RA may result in non-consideration of their bids, in case BHEL decides to go for RA.



2. b.Those bidders who have given their acceptance for Reverse Auction (quoted against this tender enquiry) will have to necessarily submit “online sealed bid” in the Reverse Auction. Non-submission of “online sealed bid” by the bidder for any of the eligible items for which techno commercially qualified, will be considered as tampering of the tender process and will invite action by BHEL as per extant guidelines in vogue.
3. BHEL will engage the services of a service provider who will provide all necessary training and assistance before commencement of on line bidding on internet.
4. In case of reverse auction, BHEL will inform the bidders the details of Service Provider to enable them to contact & get trained.
5. Business rules like event date, time, bid decrement, extension etc. also will be communicated through service provider for compliance.
6. Bidders have to fax the Compliance form (annexure IV) before start of Reverse auction. Without this, the bidder will not be eligible to participate in the event.
7. In line with the NIT terms, BHEL will provide the calculation sheet (e.g., EXCEL sheet) which will help to arrive at “Total Cost to BHEL” like Packing & forwarding charges, Taxes and Duties, Freight charges, Insurance, Service Tax for Services and loading factors (for noncompliance to BHEL standard Commercial terms & conditions) for each of the bidder to enable them to fill-in the price and keep it ready for keying in during the Auction.]
8. Reverse auction will be conducted on scheduled date & time.
9. At the end of Reverse Auction event, the lowest bidder value will be known on auction portal.
10. The lowest bidder has to fax/e-mail the duly signed and filled-in prescribed format for price breakup including that of line items, if required, (Annexure VII) as provided on case-to-case basis to Service provider within two working days of Auction without fail.
11. In case BHEL decides not to go for Reverse Auction procedure for this tender enquiry, the Price bids and price impacts, if any, already submitted and available with BHEL shall be opened as per BHEL’s standard practice.
12. Bidders shall be required to read the “Terms and Conditions” section of the auctions site of Service provider, using the Login IDs and passwords given to them by the service provider before reverse auction event. Bidders should acquaint themselves of the „Business Rules of Reverse Auction” , which will be communicated before the Reverse Auction.
13. If the Bidder or any of his representatives are found to be involved in Price manipulation/ cartel formation of any kind, directly or indirectly by communicating with other bidders, action as per extant BHEL guidelines, shall be initiated by BHEL and the results of the RA scrapped/ aborted.
14. The Bidder shall not divulge either his Bids or any other exclusive details of BHEL to any other party.
15. In case BHEL goes for reverse auction & depending on the number of bidders, the H1 bidders (whose quotes are highest in online sealed bid) may not be allowed to participate in further RA process. Further, in case of sufficient vendors, exclusion of H1 bidders may get extended up to 20%.
16. **In order to bring more transparency and to address any queries of Bidders on Reverse Auction, an abridged version of BHEL’s “Common Guidelines for**



conducting Reverse Auction (RA)” has been hosted in BHEL’s web site www.bhel.com under the links “Supplier Registration Page” and “Tender Notification”. All Bidders are requested to visit the link and familiarize themselves with BHEL’s RA procedures and guidelines before submission of their bid/s. Submission of Bid shall mean that the Bidder has read and understood BHEL’s RA procedures and the bid is in agreement with the same.

H] Force Majeure

If at any time during the currency of this contract, the performance in whole or in part, by either party of any obligations under this contract shall be prevented or delayed by reason, of any war, hostilities, acts of the public enemy, civil commotion, sabotage, fires, explosions, epidemics, quarantine, restrictions or acts of GOD (hereinafter referred to as events), then provided notice of happening of any such events is given by either party to other within ten days from the date of occurrence thereof, neither party shall reason of such events be entitled to terminate this contract nor shall either party have any such non performance and delay is resumed as soon as practicable after such events has come to an end or ceased to exist. If the performance in whole or part of any obligation under this contract is prevented or delayed by reason or any such event claims for extension of time shall be granted for period considered reasonable by the purchaser subject to prompt notification by the seller to the purchaser of the particulars of the events and supply to the purchaser if required of any supporting evidence. Any waiver of time in respect of partial installment shall not be deemed to be a waiver of time in respect of remaining deliveries.

I] Cancellation of Order:

In the event of non-performance of the contract by the Supplier, BHEL reserves the right to cancel the order with issue of a written notice. BHEL would provide a curing period of 30 days, for the Supplier to rectify the situation. If the Supplier fails to rectify the reason/s that led to the issue of cancellation notice by BHEL, then the cancellation order would be issued automatically by BHEL, without further recourse to the Seller. BHEL will not pay any cancellation charges or any other charges / damages to the Supplier, arising out such cancellation. In the event of the non-performance of the supply contract, by the Supplier, the rights of BHEL include, in addition to cancelling the order, to take alternate purchase action at the cost and risk of the supplier. The additional expenditure to be incurred by BHEL in such alternate purchase would be to the account of the supplier. (Risk Purchase). This remedy would be in addition to the invoking of the CEBG on grounds of failure of the Supplier in executing the Contract and any other legal remedies." BHEL reserves the right to initiate the alternate purchase action at the cost and risk of the erring supplier by issue of a simple notice of intention for the alternate purchase action duly sent by any electronic means and / or by a letter. The cancellation of the order would not be a pre-condition for initiation of the alternate purchase action.

J] Contract Execution Bank Guarantee:

To demonstrate the fidelity of the successful bidder, in executing the Contract, on receipt of the Letter of Intent / Purchase Order, the Supplier shall arrange to provide a contract execution bank guarantee (CEBG). The format of the CEBG is a part of this enquiry. The format may be downloaded and necessary stamping may be obtained from the Banker towards submission of the CEBG. The indigenous suppliers have to provide the CEBG from any one of the Nationalized Banks, listed in the annexure to these terms. Overseas suppliers can submit the CEBG from any of the reputed International / National Bankers. However the CEBG is to be confirmed by any of the Bankers listed by us. In the event of failure by the Supplier to execute the contract either fully or partially, BHEL would encash the entire CEBG. The CEBG shall be valid for the period covering the agreed delivery date of the order with a further claim period of 3 months on the



last specified delivery date. In the event of the failure of delivery BHEL would proceed with encashing the CEBG without reference to the Supplier. In the event of BHEL granting extension of the delivery dates, then the CEBG validity shall also be got extended by the Supplier to the extent of the extended delivery times together with the claim period as specified elsewhere. **The CEBG shall be for a value of 2% of the Purchase order.**

Suppliers who are all already registered with BHEL and having a vendor performance rating of A or A+ grade would be exempted from submission of CEBG.

Performance Bank Guarantee

Where ever so required, the Supplier shall arrange to provide a Performance bank guarantee (PBG). The indigenous suppliers have to provide the PBG from any one of the Nationalized Banks, listed in the tender terms. Overseas suppliers can submit the PBG from any of the reputed International / National Bankers. However the PBG shall be confirmed by any of the Bankers listed by us. The PBG shall guarantee the performance of the equipment / materials / items supplied and shall cover the guarantee period. The PBG shall have a claim period of 3 months in addition to the guarantee period. In the event of failure of the supplies made within the guarantee period, BHEL would encash the entire PBG. **The PBG shall be for a value of 10% of the Purchase order.**

The supplier/s have to get the PBG format (pre-printed) from BHEL and get the same stamped by the Banker. Change of PBG terms either by the supplier's Banker or by the supplier, after servicing of the order is not acceptable. Similarly PBG prepared by the supplier (typed by them) will also not be acceptable to BHEL. The pre-printed form issued by BHEL shall be used for making the PBG.

K] Post-order submission of documents for approval

In the event of the release of Letter of Intent (LoI) / Purchase order/s (PO) against this tender, Bidders have to submit the applicable documents as called for in the tender / LoI / PO/s, such as drawings, data sheets, design calculations etc. These documents for approval have to be submitted within the agreed timelines between BHEL and Bidder. Normally the time period for submission for approval is 15 days from the date of receipt of the LoI / PO by the supplier. The actual time period within which the documents have to be submitted for approval would be specified in the LoI / PO.

Such documents would be subjected to evaluation and approval by BHEL and / or by BHEL's customer / Consultant / Customer's Consultant. Bidders have to give their specific acceptance for this.

After approval of such documents and after getting clearance from BHEL, only the items ordered can be taken up for manufacture.

Any changes required by BHEL / Customer etc. in the documents submitted for approval shall be incorporated by the Bidder and no extra cost would be payable by BHEL for such changes.

In the event that the Bidder does not carry out the required corrections, then the LoI / PO would be liable for cancellation by BHEL and BHEL would resort to alternate purchase action at the risk and cost of the Bidder under the Risk Purchase Condition of the Purchase Order.

Note: After receiving the LoI / PO, supplier shall also forward the acknowledgement / acceptance of the LoI / PO by signing and returning the second copy of the LoI / PO as the token of acceptance.

L] Others

a) In case of any contradiction in the terms and conditions given here and elsewhere in the other documents of the tender, it shall be the responsibility of the tenderer to get it clarified from BHEL. The officer authorized to provide such clarifications is the tender issuing officer.

b) Alterations to the conditions of the Tender can be done only by the authorized officer, at any time before the date and time of tender opening and would be duly communicated through a corrigendum.



c) Suspension of Business dealings with Suppliers:

(i) Before submitting offer, prospective bidders are advised to visit our web-site www.bhel.com / supplier registration to familiarize themselves with BHEL's policy and procedures of Suspension of Business Dealings with Suppliers.

Submission of offer shall be deemed to be evidence of the Bidder to have read and understood the above said policy.

ii) Treatment of Banned / Under-performing Vendors:

Any supplier who has been put on "Hold" or "Banned" from having business dealings with BHEL, Ranipet or any other unit of BHEL shall not submit their offer against this tender. If any such offers are received they would be summarily rejected and sent back. During the processing of tender, if any unit of BHEL puts a supplier on "Ban" then further processing of the offer will not be taken up and in case an order is placed, BHEL, Ranipet may resort at their discretion to cancel the PO either fully or partially.

If any of the supplier who is supplying similar material to BHEL, Ranipet has a Vendor Performance Rating (VPR) score of 'C' or below, then offer given by such parties will not be considered for ordering in this tender.

d) Fraud Prevention Policy:

The Bidder along with its associate/ collaborators/ sub-contractors/ sub-vendors/ consultants/ service providers shall strictly adhere to BHEL Fraud Prevention Policy displayed on BHEL website <http://www.bhel.com> and shall immediately bring to the notice of BHEL Management about any fraud or suspected fraud as soon as it comes to their notice.

e) **Applicability of Integrity Pact:-** Integrity Pact are applicable for all the BHEL enquiries whose estimated value is equal to or more than Rupees 05 Crores. Submission of duly-filled & signed BHEL standard format of Integrity Pact (without any deviation) by Suppliers along with the un-priced (Techno-Commercial) bid is pre-requisite condition for evaluation of the offer. Copy of Integrity Pact with applicable nominated IEM is attached along with the tender documents for ready reference of Suppliers. If any Supplier attempts to bribe, or pay commission, gift or any advantage or bring in undue influence either by himself or on his behalf any one including a stranger to the tender, in addition to instituting legal proceedings as per the extant laws prevailing, will disqualify the supplier from this tender and all future tenders of BHEL. Decision of the Purchaser would be final in this matter.

f) The laws governing this transaction shall be the laws in India.

g) Wherever not specified, Inco terms 2010 shall be used to interpret the Commercial terms and conditions and

h) In the event of an order, Supplier shall agree to settlement of disputes or differences, if any, by way of arbitration, in accordance with the "Rule of Arbitration" of the Indian Council of Arbitration.

The language in the tender documents downloaded by the Bidders shall at no point of time be changed, altered or modified in any manner by the Tenderer. If such changes are made by any tenderer, it shall be considered as tampering with BHEL's terms and the offer shall be summarily rejected, whenever it is noticed by BHEL. Such Bidders would be disqualified from the Bidding Process and their offers would be forfeited / Bank Guarantees invoked. They would also not be allowed to participate in future tenders of BHEL.



**ANNEXURE - C TO OPEN TENDER No: 5551422E / 29.02.2016 FOR SUPPLY OF FORGED AND PROOF MACHINED COMPONENTS
CHECK LIST STANDARD COMMERCIAL TERMS & CONDITIONS**

S No.	BHEL Standard Terms	Supplier Confirmation	Deviation (if any)
01	Terms of Delivery:		
(a)	Indigenous Supplies : FOR - Destination means FOR - BHEL Stores, Ranipet [Packing & Forwarding, Freight & Insurance are in Supplier's scope i.e. included in the quoted prices. Unloading at BHEL Stores would be to the account of BHEL only].		
(b)	Foreign Supplies : CFR Chennai Sea Port Basis only and Insurance in BHEL's scope.		
02	Delivery Period: To mention clearly the exact delivery period as it attracts contractual penalty on delays.To be indicated in days/weeks/months from date of receipt of Purchase Order (P.O)		
03	Liquidated Damages (LD) : The applicable LD shall be at the rate of 0.5% per week to maximum of 10% for the undelivered portion and for the deliveries made beyond the agreed Delivery Period. Delivery being the essence of BHEL's contract requirements, in the event that a Supplier does not accept the above LD condition, the offer would be loaded to the extent of the shortfall with respect to upper limit specified above.		
4 (a)	Terms of payment for Indigenous Suppliers: 100% within 45 days for MSE(micro & small) and within 90 days for non-MSE after receipt & acceptance of materials at our stores. If any supplier is asking for payment terms other than the above specified, then suitable loading on cost will be considered. Loading of any deviation in the payment terms w.r.t tender terms will be "Base rate of State Bank of India (SBI) (as applicable on the date of bid opening: Techno-commercial bid opening in case of two part bids) + 6%, will be considered for loading for the periods of relaxation sought by bidders.		
4 (b)	Terms of Payment for Foreign Suppliers: "100% thru' irrevocable & unconfirmed LC at sight within 3 weeks from the PO date through any one of our Bankers listed elsewhere in the tender conditions for 100% value (less Agency Commission, if any) valid upto the PO delivery period and 15 days thereafter for negotiation. All bank charges in India to BHEL's account and all other charges outside India to Supplier's account. BHEL reserves the right to load the price of foreign suppliers in order to bring them on common platform as per Indigenous Suppliers on the account of differential payment terms to Indigenous Suppliers. Loading of payment terms will be "Base rate of State Bank of India (SBI) (as applicable on the date of bid opening: Techno-commercial bid opening in case of two part bids) + 6%, will be considered for loading for the periods of relaxation compared to indigenous suppliers i.e. 90 days.		
05	Whenever there is an Indian Agent to represent a Supplier, it is mandatory to give the details of services to be rendered by Indian Agent and / or the details of agreement between Supplier and Agent. Supplier to indicate the Agency Commission payable. Indian Agency Commission will be paid only in Indian Rupees, calculated at the rate of exchange prevailing on the date of price bid opening. This is payable on satisfactory completion of the contract. Agency agreement copy shall be submitted along with Annexure-C without fail. Note: In order to maintain sanctity of the tender system, it is mandatory that one Agent cannot represent two Suppliers or quote on their behalf in a particular tender enquiry. If any Agent represents more than one Suppliers all such offers will be rejected.		



**ANNEXURE - C TO OPEN TENDER No: 5551422E / 29.02.2016 FOR SUPPLY OF FORGED AND PROOF MACHINED COMPONENTS
CHECK LIST STANDARD COMMERCIAL TERMS & CONDITIONS**

S No.	BHEL Standard Terms	Supplier Confirmation	Deviation (if any)
06	Guarantee Period: Guarantee regarding manufacturing defect should be for a period of 12 months from date of acceptance of the materials at BHEL Stores, or 18 months from the date of shipment whichever event occurs earlier.		
07	Contract Execution Bank Guarantee (CEBG): The Supplier shall submit a BG for 2% of the contract value valid for the agreed delivery period + 3 Months. Attached CEBG Format is to be signed and submitted along with Annexure-C as a token of acceptance. Please note no deviation is allowed.		
08	Validity: Supplier to mention clearly the validity date of the offer. Minimum 90 days from first tender opening date and 60 days from the date of the Reverse Auction/Price bid opening date;		
09	Clientele List: Supplier to submit detailed clientele list with their full address including detail of contact person with phone no., fax no. & e-mail ID as per clause A(j) of Annexure - B (STANDARD TERMS & CONDITIONS).		
10	Reverse Auction (R/A) / Bidding through Internet: Supplier confirmation required.		
11	Taxes & Duties:		
(i)	Excise duty in % (for Indigenous supplier): To be indicated by supplier. ED invoice is required for availing Cenvat. benefit		
(ii)	Sales tax in % (for Indigenous supplier): VAT / CST to be indicated by the supplier. In case of TNVAT, VAT input credit will be restricted to 2% only.		
12	Test Certificate: To be submitted. With Chemical and Mechanical properties and dimensions as per Standards and our Technical Delivery Conditions		
13	Risk Purchase Clause (as per clause-I of Annexure-B) (Supplier Confirmation Required)		
14	For Foreign Offers:		
(i)	Manufacturers' Name and address:		
(ii)	Country of Origin:		
(iii)	Mills Letter of Authority		
(iv)	Agency Agreement		
(v)	Approximate weight and cubage of the consignment.		
15	Firm price till completion of order		
16	Inspection before despatch at supplier's works by BHEL/TPI agency		
Signature & Office Seal of Vendor			

(TO BE STAMPED IN ACCORDANCE WITH STAMP ACT AND THE EXPIRY DATE OF BG MUST BE AFTER 3 MONTHS FROM THE DATE OF COMPLETION OF SUPPLIES)

CONTRACT EXECUTION BANK GUARANTEE

In accordance of M/s. Bharat Heavy Electricals Limited (A Government of India undertaking, a company incorporated under the Companies Act 1956 having its Registered Office at "BHEL House", SIRI Fort, New Delhi 110 049) through its Boiler Auxiliaries Plant located at Ranipet – 632 406, (hereinafter called 'the Company') having entered into a contract with M/s.....
..... hereinafter called 'the said contractor' which term includes 'suppliers' for the purpose of this Bond and under the terms and conditions of the Contract No.....Dt.....between BHEL, Ranipet and as per the Contract, the Contractor / Supplier is to furnish a Contract Execution Bank Guarantee for Rs.....in words.....
.....for the due performance of the contract and for the fulfillment of all the terms and conditions of the contract.

Sign and seal of issuing bank
Please affix Non Judicial Stamp
here, as per Stamp Act

Bank Guarantee No.....Date.....Banker Name.....
Bank Guarantee Value Rs.....

1. We.....
.....
.....(Bank's name, Branch, Place – address to be mentioned [herein after referred to as the Bank) at the request of.....
.....(Contractor(s)] do hereby undertake to pay the company an amount not exceeding Rs.....in words
.....
.....against any loss or damage caused to or suffered or would be caused to or suffered by the company by reason of any breach by the said Contractor(s) of any of the terms and conditions contained in the said agreement.

2. We.....
.....(name of the bank with full address), do hereby undertake to pay the amounts due and payable under this guarantee without any demur, merely on a demand from the Company stating that the amount claimed is due by way of loss or damage caused to or would be caused to or suffered by the Company by reason of breach by the said Contractor(s) of any of the terms and conditions contained in the said Agreement or by the reason of the Contractor(s) 'failure to perform' the said agreement. Any such demand made on the Bank shall be conclusive as regards the amount due and payable by the Bank under this guarantee. However, our liability under this guarantee shall be restricted to an amount not exceeding Rs.....in words.....

Sign and seal of issuing bank

Bank Guarantee No.....Date.....Banker Name.....
Bank Guarantee Value Rs.....

3. We undertake to pay conditionally to the Company any money so demanded notwithstanding any dispute(s) raised by the Contractor in any suit, or proceedings pending before any Court or Tribunal or Arbitration or before any other authority relating thereto our liability under this present being absolute and unequivocal. The payment under this guarantee would not wait till the disputes have been decided by any Court or Tribunal or in the arbitration proceedings or by any other authority. The payment so made by us under this Bond shall be a valid discharge of liability for payment thereunder and the Contractor(s) shall have no claim against us for making such payment.

4. We.....(name of Bank), further agree that the guarantee herein contained shall remain in full force and effect during the period that would be taken for the performance of the said Agreement and that it shall continue to be enforceable till all the dues of the Company under or by virtue of the said Agreement have been fully paid and its claims satisfied or discharged or till Purchase Department of the Company certifies that the terms and conditions of the said Agreement have been fully and properly carried out by the said Contractor(s) and accordingly discharges this guarantee.

5. (i) Unless a demand or claim under this guarantee is made on us in writing on or before(date) (After 3 months from the date of completion of supplies) we shall be discharged from all the liability under this guarantee thereafter. But where such claim or demand has been preferred by the Company with the Bank before the expiry of the said date, the claim shall be enforceable notwithstanding the fact that the said enforcement is effected after the said date. (ii) For the purpose of this clause, any letter making demand on the Bank by M/s. BHEL dispatched by Registered Post with Ack. Due or by Telegram or by any Electronic media addressed to the above mentioned address of the Bank shall be deemed to be the claim / demand in writing referred to above irrespective of the fact as to whether and when the said letter reaches the Bank, as also any letter containing the said demand or claim is lodged with the Bank personally.

Sign and seal of issuing bank

Bank Guarantee No.....Date.....Banker Name.....
Bank Guarantee Value Rs.....

6. We.....(name of the Bank), further agree with the company that the Company shall have the fullest liberty without our consent and without affecting in any manner our obligations hereunder to vary any of the terms and conditions of the said agreement or to extend time of performance by the said Contractor(s) from time to time or to postpone for any time or from time to time any of the powers exercisable by the Company against the said Contractor(s) and to forbear or enforce any of the terms and conditions relating to the said Agreement and we shall not be relieved from our liability by any reason of any such variation or extension being granted to the said Contractor(s) or for any forbearance, act or omission on the part of the company or any indulgence by the company to the said Contractor(s) or by any such matter or thing whatsoever which under the law relating would, but for this provision, have effect of not so relieving us.

7. This guarantee will not be discharged due to the change in the constitution of the Bank or the Contractor(s).

8. The guarantee herein contained shall not be determined or affected by the liquidation or winding up or insolvency of or change in the constitution of the Contractor, but shall in all respects and for all purpose be binding and operative until all payments of all moneys due or that may hereafter become due to the said company or settled irrespective of any liability or obligation of the Contractor under the said Contract.

9. It shall not be necessary for the company to proceed against the Contractor before proceeding against the guarantor-bank and the guarantee herein contained shall be enforceable against them notwithstanding any security, which the company may have obtained from the Contractor shall, at the time when proceedings are taken against the Guarantor hereunder be outstanding or unrealized.

10. Any claim or dispute arising under the terms of this document shall only be enforced or settled in the Courts at Ranipet, Tamilnadu Jurisdiction.

11. The Bank declares that it has powers to issue this Guarantee under the Bank's Memorandum and Articles of Association and the undersigned has full powers to do so on its behalf under the power granted to him by the proper authorities of the Bank.

12. We(name of Bank) lastly undertake not to revoke this guarantee during its currency except with the previous consent of the company in writing.

In witness whereof we.....
(name of Bank) have hereunto setout Bank Seal the.....
day of.....month 20__.

Sign and seal of issuing bank.

CAUTION: The information on this document is the property of BHARAT HEAVY ELECTRICALS LTD. It must not be used directly or indirectly in any way detrimental to the interest of the company.

REV	DATE	ALTERED
		CHECKED

ALL DIMENSIONS ARE IN MILLIMETRES

FOR PRODUCTION
 REF. PR:QA:590 FOR PAINTING
 REF. PR:QA:500 FOR UNTOL. DIMNS.
 REF. APPLICABLE GMS FOR MATCODE&SPEC.

6.3

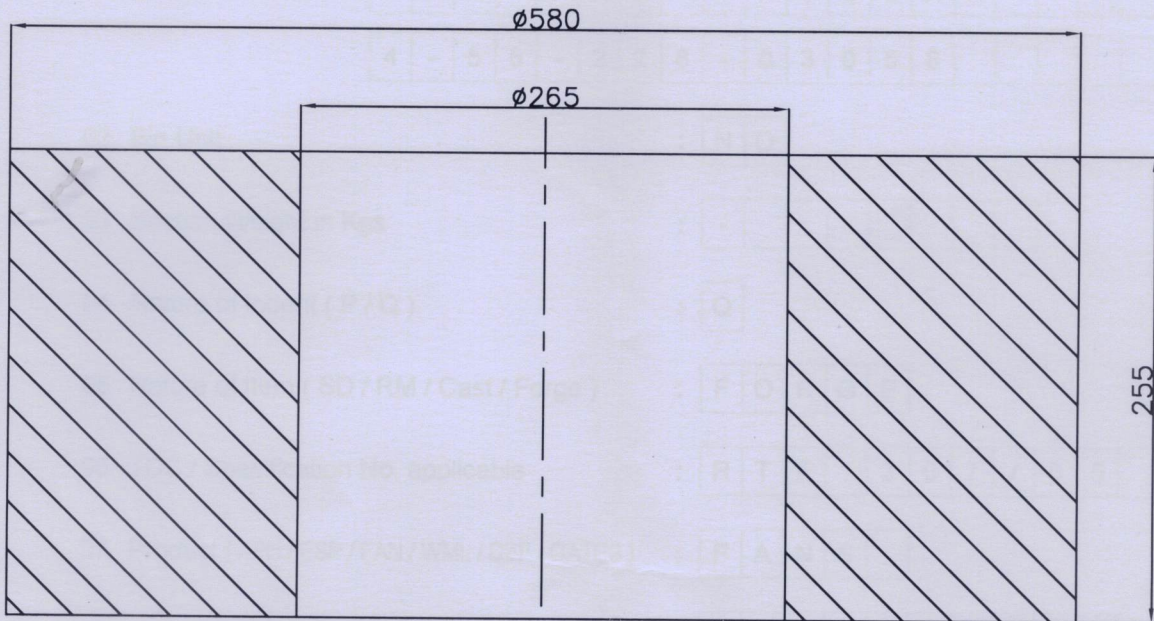

NOTES: -
 REFER TDC:RTF:307/05 FOR DELIVERY CONDITIONS

01	WELDING HUB					418.5	
VAR NO	ITEM NO	DESCRIPTION	CAT	DRAWING No.	NO VAR NO	MATL CODE	UNIT WT
						P500 NH	1
						MATL SPECN	QTY

CAUTION: The information on this document is the property of BHARAT HEAVY ELECTRICALS LTD. It must not be used directly or indirectly in any way detrimental to the interest of the company.			BHARAT HEAVY ELECTRICALS LTD., UNIT: BOILER AUXILIARIES PLANT, RANIPET - 632 406.		DRN	NAME	SIGN	DATE	NO. OF VAR.
					CHD	RATNABABU		30.01.16	
					APPD	A.V.N		30.01.16	
	DEPT	FANS	GRADE OF UNTOL. DIM	SCALE	WEIGHT (KG).	REF. TO ASSY/OLD DRG.			ITEM NO.
CODE	864	PR: QA: 500	N.T.S	418.5	V7008370				
TITLE					CARD CODE	DRAWING NO.			REV
WELDING HUB (RAW PART)					U 01	4-55-228-03058			

Size A4

CAUTION: The information on this document is the property of BHARAT HEAVY ELECTRICALS LTD. It must not be used directly or indirectly in any way detrimental to the interest of the company.

REV	DATE	ALTERED
		CHECKED

ALL DIMENSIONS ARE IN MILLIMETRES

FOR PRODUCTION
 REF. PR:QA:590 FOR PAINTING
 REF. PR:QA:500 FOR UNTOL. DIMNS.
 REF. APPLICABLE GMS FOR MATCODE&SPEC.

6.3

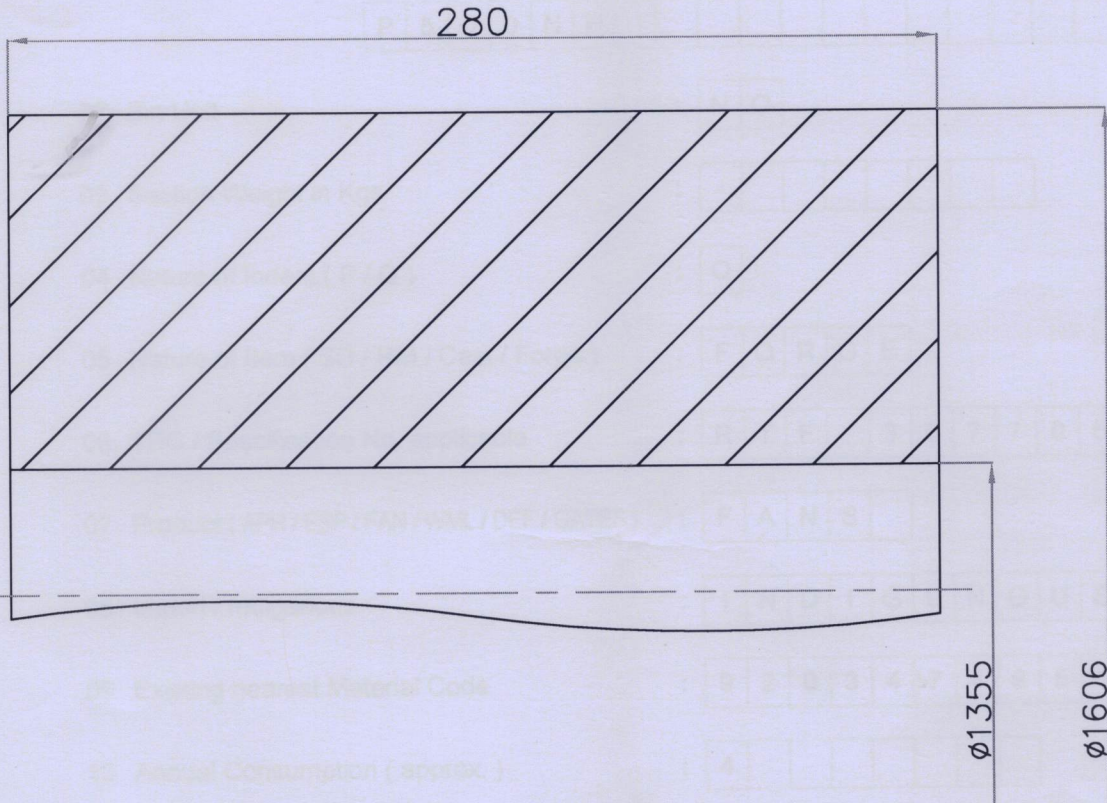

NOTES: -

- 1.REFER TDC:RTF:307/05 FOR DELIVERY CONDITIONS
- 2.PROOF MCD WT 1283Kgs

VAR NO	01	LOAD RING	CAT	DRAWING No.	NO VAR NO	P500 NH	UNIT	979.600	1	CS	ZONE
						MATL CODE	DI	UNIT WT	QTY		
						MATL SPECN					

CAUTION: The information on this document is the property of BHARAT HEAVY ELECTRICALS LTD. It must not be used directly or indirectly in any way detrimental to the interest of the company.			BHARAT HEAVY ELECTRICALS LTD., UNIT: BOILER AUXILIARIES PLANT. RANIPET - 632 406.		DRN	P.SURESH	SIGN	DATE	NO. OF VAR.
					CHD	RATNABABU		30.01.16	
					APPD	A.V.N		30.01.16	
	DEPT	FANS	GRADE OF UNTOL. DIM	SCALE	WEIGHT (KG).	REF. TO ASSY/OLD DRG.		ITEM NO.	NO. OF ITEMS
979.60	DDE	864	PR: QA: 500	N.T.S	979.600	V7017267			
TITLE					CARD CODE	DRAWING NO.		REV	
LOAD RING					U 01	4-55-228-03060			

CAUTION: The information on this document is the property of BHARAT HEAVY ELECTRICALS LTD. It must not be used directly or indirectly in any way detrimental to the interest of the company.

REV	DATE	ALTERED
		CHECKED

ALL DIMENSIONS ARE IN MILLIMETRES
FOR PRODUCTION
 REF. PR:QA:590 FOR PAINTING
 REF. PR:QA:500 FOR UNTOL. DIMNS.
 REF. APPLICABLE GMS FOR MATCODE&SPEC.

6.3

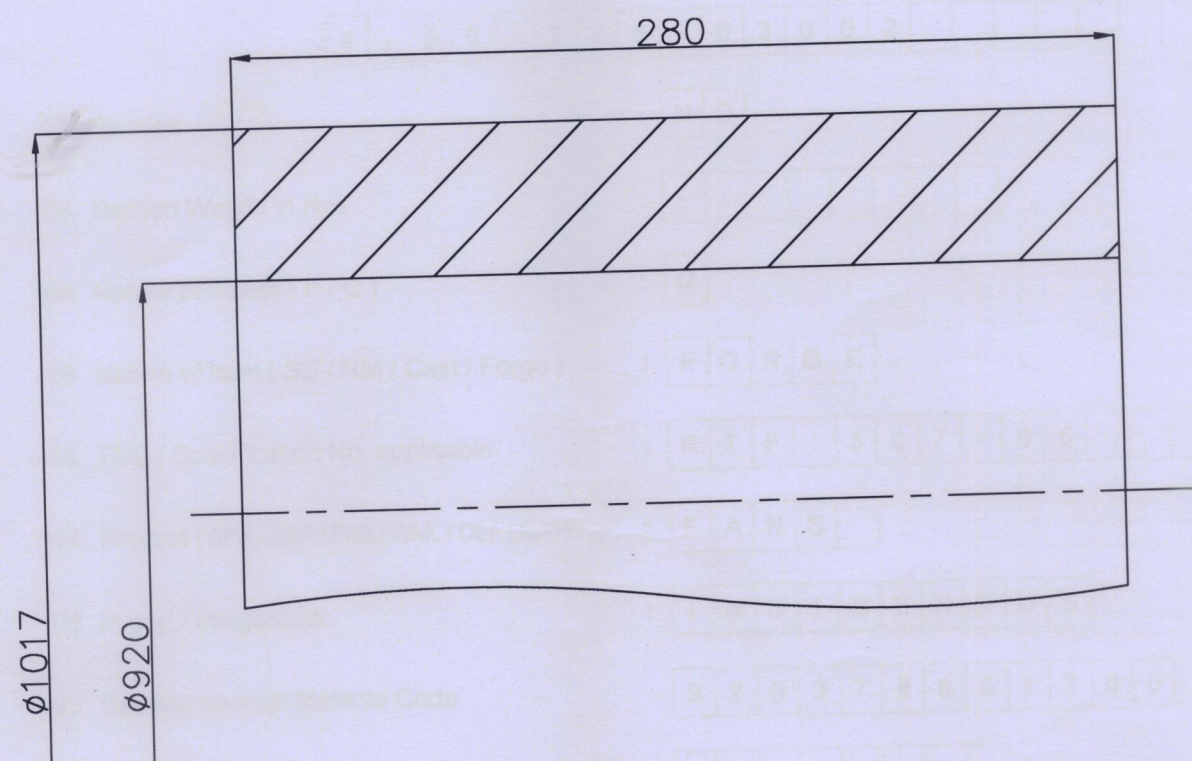

NOTES: -
 1.REFER TDC:RTF: 307/05 FOR DELIVERY CONDITIONS
 2.PROOF MCD WT 322.80Kgs

VAR NO	ITEM NO	DESCRIPTION	CAT	DRAWING No.	NO VAR NO	MATL SPECN	A CTD	UNIT DI	UNIT WT	QTY	192.800	1	1	1
--------	---------	-------------	-----	-------------	-----------	------------	-------	---------	---------	-----	---------	---	---	---

CAUTION: The information on this document is the property of BHARAT HEAVY ELECTRICALS LTD. It must not be used directly or indirectly in any way detrimental to the interest of the company.			BHARAT HEAVY ELECTRICALS LTD. UNIT: BOILER AUXILIARIES PLANT. RANIPET - 632 406.		DRN	P.SURESH	SIGN	30.01.16	NO. OF VAR.
	DEPT	FANS	GRADE OF UNTOL.DIM	SCALE	WEIGHT (KG).	CHD	RATNABABU	30.01.16	
	CODE	864	PR:QA:500	N.T.S	192.800	APPD	A.V.N	30.01.16	
	TITLE					CARD CODE	DRAWING NO.		ITEM NO.
SUPPORT RING					U 01	4-55-228-03062			REV

DRAWING NO.
3-55-227-01857

ALL DIMENSIONS ARE IN MILLIMETRES
FOR PRODUCTION
REF. PRO-450 FOR PAINTING
REF. PRO-450 FOR UNTOL. DIMS.
REF. APPLICABLE GHS FOR MATCODE&SPEC.

6.3

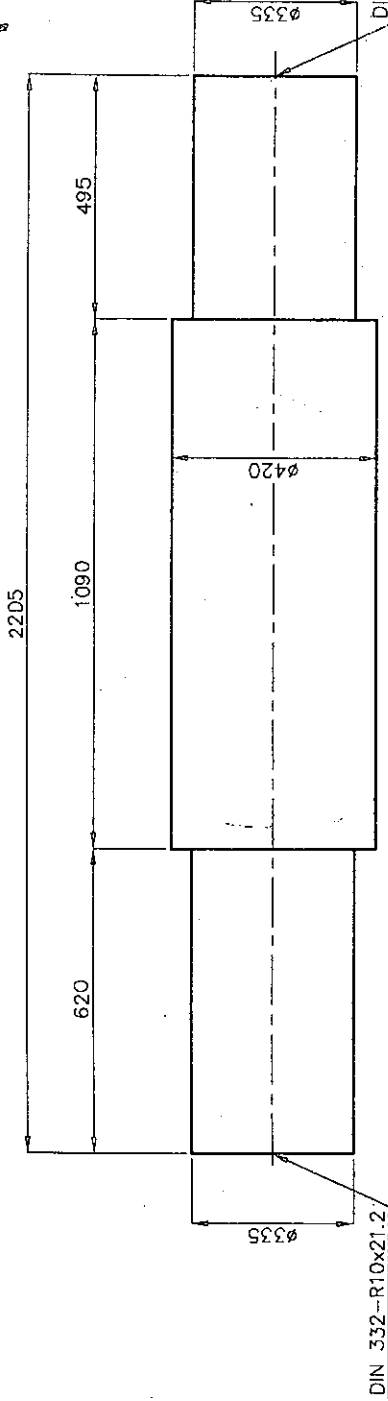

DIN 332-R10x21.2

DIN 332-R10x21.2

DELIVERY CONDITION:—
01. ACCORDING TO "TFN NO.361" DELIVERY SPECIFICATIONS OF QUENCHED AND TEMPERED STEEL 42CrMo4V+QT

VAR ND	ITEM ND	DESCRIPTION	DRAWING No.	920374730600	1956.930
				42CrMo4V+QT	1
				MATL CODE	UNIT WT
				MATL SPECN	QTY

TYPE OF PRODUCT
OR NAME OF CUSTOMER/PROJECT

BHARAT HEAVY ELECTRICALS LTD.,
UNIT: BOILER AUXILIARIES PLANT,
RANIPET - 632 406.

DEPT: FANS
GRADE OF UNTOL.DIM: PR-04.500
SCALE: N.T.S.

DRN: P.SHAKI.O/L
CHD: MAHESH
APPD: P.M.J.

NAME: P.SHAKI.O/L
SIGN: _____
DATE: 06.11.12

WEIGHT (KG): 1956.930
REF. TD ASSY/OLD DRG.: V7007957

REV: 01
DRAWING NO.: 3-55-227-01857

CAUTION: The information on this document is the property of BHARAT HEAVY ELECTRICALS LTD. It must not be used directly or indirectly in any way detrimental to the interest of the company.

REV DATE ALTERED
CHECKED

Size A3

This document is the property of BHARAT HEAVY ELECTRICALS LTD. It must not be used directly or indirectly in any way detrimental to the interest of the company.

PR

REV	DATE	ALTERED
		CHECKED

ALL DIMENSIONS ARE IN MILLIMETRES

FOR PRODUCTION
 REF. PR:QA:590 FOR PAINTING
 REF. PR:QA:500 FOR UNTOL. DIMNS.
 REF. APPLICABLE GMS FOR MATCODE&SPEC.

6.3

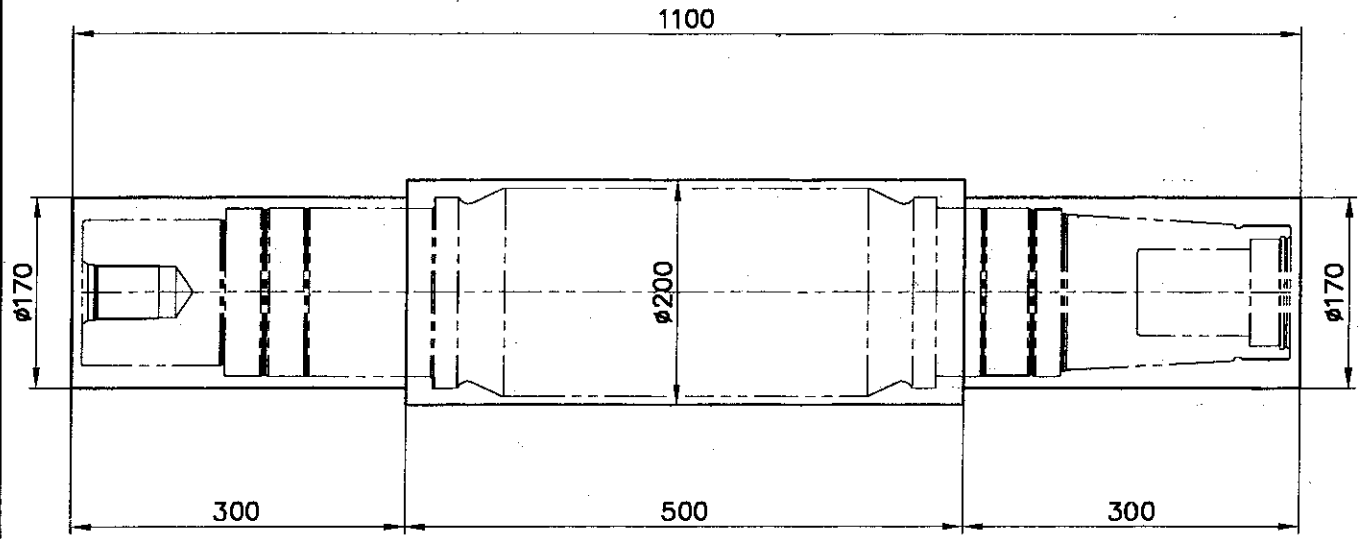

DELIVERY CONDITION:-

01. ACCORDING TO "TFN NO.361" DELIVERY SPECIFICATIONS OF QUENCHED AND TEMPERED STEEL 42 Cr Mo4 V

01	FORGING	920374730400	230	200
		42 Cr Mo4V		1
ITEM NO.	DESCRIPTION	MATL. CODE	A	UNIT
		MATL. SPECN.	C	DI
				UNTT WT.
				QTY



BHARAT HEAVY ELECTRICALS LTD.,
 UNIT: BOILER AUXILIARIES PLANT,
 RANIPET - 632 406.

DRN	NAME	SIGN	DATE	NO. OF VAR
CHD	P.SHAKI.O/L			
APPD	MAHESH			
	P.M.J			

SCALE	WEIGHT (KG).	REF. TO ASSY./OLD DRG.	ITEM NO.	NO. OF ITEMS
NTS	230.200			

I AN SHAFT
 (FORGING)

CARD CODE
 U 01

DRAWING NO.
4-55-215-02685

REV

 Ranipet	Technical Delivery Condition(TDC) For Guide /Support trunnion, Adaptor plate/ sleeve, cascade evaporator shaft Forgings	Doc Ref:	TDC:RTA:403
		Rev.No.	0 1
		Date:	10 05 2002
		Page No	Page 1 of 2

1.0 Scope

- 1.1 This TDC covers the requirement of the following APH components in the proof machined condition with the following material specification and heat treatment.

Item Description	Material Specification	Heat Treatment condition
Guide Trunnion, Support Trunnion, Adaptor Plate, cascade evaporator shaft	AISI 1050	Quenched & Tempered
Adaptor sleeve, Header plate	AISI 1020	Normalised
Adaptor sleeve	AISI 4140	Normalised

2.0 Chemical & Mechanical properties

2.1 Chemistry.



SPECN	C	Mn	P	S	Si	Cr	Mo
AISI 1050	0.48-0.55	0.6-0.9	0.04(max)	0.05(max)	--	--	--
AISI 1020	0.18-0.23	0.3-0.6	0.04(max)	0.05(max)	0.15 (min)	--	--
AISI 4140	0.38-0.43	0.8-1.0	0.035(max)	0.04(max)	0.15-0.3	0.8-1.1	0.1-0.25

2.2 Mechanical Properties.

Specification	TS(Min)kg/sq.mm	YS(min)kg/sq.mm	%Elong	Hardness
AISI 1050	63.27	37.26	19	187 - 235
AISI 1020	42.18	21.09	24	120 - 174
AISI 4140	71.71	56.24	20	220 - 250

3.0 Supply Condition.

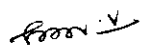
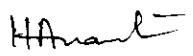
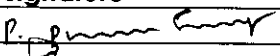
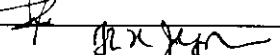
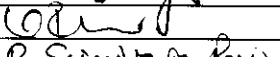
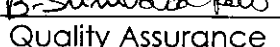
- 3.1 Requirements of forgings shall be as per ASTM A 668.
- 3.2 In case of the first order on a vendor, the vendor shall furnish the rough forging drawing indicating the flow lines along with the offer.

Prepared by 	Reviewed by	Signature	Approved by  H.Amant (Head/QA)
	Engg(APH)		
	Purchase		
	MPL		
	QC/proc.		
QA			
Issued by : Quality Assurance			

	Technical Delivery Condition(TDC) For Guide /Support trunnion, Adaptor plate/ sleeve, cascade evaporator shaft Forgings	Doc Ref:	TDC:RTA:403
		Rev.No.	0 1
		Date:	10 05 2002
		Page No	Page 2 of 2

- 3.3 Mechanical Testing: The testing and retesting of mechanical properties (if needed) shall be done on a test specimen which shall be from an extension of forgings as per ASTM A 668.
- 3.4 Suggested minimum forging reduction from starting piece to finished forging is 1:4 with favorable grain flow. The dimensions for forgings shall confirm to the requirement of proof machined drawings.

4.0 Non Destructive Testing & Acceptance

- 4.1 All forgings shall be UT tested radially and axially as per ASTM A388 using straight beam method.
- 4.2 When back wall Echo is set to 100 % of FSH in Sound area
- Defect echo not to exceed 20 % of FSH during scanning.
 - Back wall echo loss permissible 20 % of FSH.
- 4.3 The forging shall be visually inspected for surface defects and wherever doubt arise shall be inspected by MPI and shall be free from any longitudinal or transverse indications.

5.0 Marking

- 5.1 All forgings shall be hard stamped with specification, melt no., sl no., Supplier's name / emblem on the flat surface of the forgings.

6.0 Test Certificate

- 6.1 TCs shall be in English and it shall contain:
- | | |
|-------------------------------------|--|
| a) Purchase order number and date | g) Heat treatment condition and particulars |
| b) TDC number | h) Mechanical properties – melt wise/heat treatment batch wise |
| c) Specification and grade | i) Dimensional report |
| d) Drawing number | j) Ultrasonic test report |
| e) Quantity | |
| f) Chemical composition – melt wise | |
- 7.0 BHEL reserves the right to carryout test and reject the items wherever non conformance to the Contract is noticed.

Rev.No	Date	Changes made
00	26 02 02	TDC RTA 003/REV 05 is revised and re-numbered as TDC RTA 403/REV 00
01	10 05 02	Totally reviewed and revised for better clarity and requirements of TDC RTA 411/rev00 and TDC RTA 422 rev 00 included .TDC RTA 411 ,422 is deleted



Ranipet

Technical Delivery Condition (TDC)
For
**IMPELLER RING, HUB DISC,
SUPPORTING BODY & FAN FORGINGS.**

P355NH/QH of EN 10222-4,
WSTE 500/ P500 NH of 1.8937, P460NH(1.8935) and SA 592
Gr.F of ASTM A 592

Doc Ref:	TDC:RTF:307
Rev No:	05
Date:	27.07.2015
Page No:	1 of 6

1.0 SCOPE

- 1.1 This TDC specifies the requirements for the supply of proof machined impeller ring, hub disc, supporting body & fan forgings.
- 1.2 This TDC is in line with EN 10222-4 for P355NH/QH, 1.8937 for WSTE 500/P500NH, 1.8935 for P460NH, ASTM A 592 for SA 592 Gr F additional requirements are incorporated in Thi TDC.
- 1.3 In accordance with the dimensions in the drawing of the purchaser, the forgings (load ring, welded-in hub etc.) shall be supplied in the pre-machined condition ($R_z \leq 63 \mu\text{m}$). Rolled stock may be supplied for these parts only with the express consent of the customer.

2.0 MATERIAL: WSTE 500/ P500 NH, 1.8937

As-received condition: Quenched and tempered (V) or normalized (N) The choice of the heat treatment is optional to the manufacturer. As a rule, products having a thickness of $>100 \text{ mm}$ are quenched and tempered whereas products with a thickness of $\leq 100 \text{ mm}$ are normalized.





Chemical composition: By ladle analysis, Weight in percent (%), as per below Table

	C	Mn	Si	P	S	Al
$> 40 \text{ [mm]}$	< 0.22	< 1.60	< 0.55	< 0.035	< 0.035	> 0.020
$\leq 40 \text{ [mm]}$	< 0.20	< 1.60	< 0.55	< 0.035	< 0.035	> 0.020

Mechanical properties: As per below Table

To be determined on longitudinal (L) or transverse (T) specimens at room temperature, except for the impact energy, which shall be determined at -20°C .

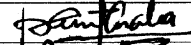
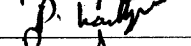
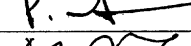
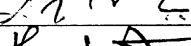
For forged and rolled stock	Product thickness in [mm]				
	≤ 50	51 - 100	101 - 150	151 - 375	376 - 600
Tensile strength R_m [N/mm ²]	610-780			540-740	
Yield point R_{eH} min. [N/mm ²]	480	450	430	410	390
Fracture elongation min. in (%)	L	17			16
	T	16			15
Impact energy min. on ISO-V specimens at -20°C [J=Nm] mean value from Three (3) individual specimens	L	38			
	T	20			

Prepared by 	Reviewed by	Signature	Approved by  30/07/2015 (Head/QA)
	ENGG(Fans)		
	QC(Proc)		
	MPLG		
	PUR		
QA			
Issued by		QUALITY ASSURANCE	

 Ranipet	Technical Delivery Condition (TDC) For IMPELLER RING, HUB DISC, SUPPORTING BODY & FAN FORGINGS. P355NH/QH of EN 10222-4, WSTE 500/ P500 NH of 1.8937, P460NH(1.8935) and SA 592 Gr.F of ASTM A 592	Doc Ref:	TDC:RTF:307
		Rev No:	05
		Date:	27.07.2015
		Page No:	2 of 6

3.0 MATERIAL: P355NH/QH, EN 10222-4

As-received condition: Normalized (N) or Quenched

Chemical composition: by cast analysis, Weight in (%), as per below table

Ruling thickness	C	Mn	Si	P	S	Al #		N	Cr	Cu	Mo	Nb	Ni	V	Nb
	Max.			Max.	Max.	Total		Max.	Max.	Max.	Max.	Max.	Max.	Max.	+V
tr ≤ 400 (in mm)	0.20	0.90- 1.65	0.10- 0.50	0.025	0.015	Min. 0.02	Max. 0.06	0.02	0.30	0.20	0.08	0.05	0.30	0.10	0.12

Minimum Al level need not apply when Nb, V and Ti are used to control N content.

Mechanical properties:

To be determined on longitudinal (L) or transverse (T) specimens at room temperature, except for the impact energy, which shall be determined at -20°C.

For forged stock	Ruling thickness t_r in [mm]					
	$t_r \leq 16$	$16 < t_r \leq 35$	$35 < t_r \leq 70$	$70 < t_r \leq 100$	$100 < t_r \leq 250$	$250 < t_r \leq 400$
Tensile strength R_m [N/mm ²]	490 to 630			470 to 630		
Yield point R_{eH} min. [N/mm ²]	355	355	335	315	295	275
Fracture elongation min. in [%]	L 23 T 21			21 19		
Impact energy min. on ISO-V specimens at -20°C [J=Nm] mean value from Three (3) individual specimens	L 40 T -			47 27		

Note 1. For ruling thickness $t_r \leq 100$ mm heat treatment condition is normalized while for $t_r \leq 400$ it is quenched and tempered.

Note 2. For P355NH/QH, hot tensile test shall be done at 300°C. Yield strength shall be as per material standard.

 Ranipet	Technical Delivery Condition (TDC) For IMPELLER RING, HUB DISC, SUPPORTING BODY & FAN FORGINGS. P355NH/QH of EN 10222-4, WSTE 500/ P500 NH of 1.8937, P460NH(1.8935) and SA 592 Gr.F of ASTM A 592	Doc Ref:	TDC:RTF:307
		Rev No:	05
		Date:	27.07.2015
		Page No:	3 of 6

4.0 MATERIAL: P460NH (1.8935)

Chemical composition: As per below table

C Max.	Si Max.	Mn	Ni Max.	P Max.	S Max.	Cr Max.	Mo Max.	V Max.	N Max.	Nb Max.	Ti Max.	Al Max.	Cu Max.	Nb+Ti +V
0.20	0.6	1.1-1.7	0.8	0.025	0.015	0.30	0.1	0.20	0.025	0.05	0.03	0.02	0.70	< 0.22

Mechanical properties:

To be determined on longitudinal (L) or transverse (T) specimens at room temperature, except for the impact energy, which shall be determined at -20°C.

For forged stock	Ruling thickness t_r in [mm]			
	$t_r \leq 16$	$16 < t_r \leq 60$	$60 < t_r \leq 100$	
Tensile strength R_m [N/mm ²]	560 to 730	570 to 720	540-710	
Yield point R_{eH} min. [N/mm ²]	$t_r \leq 16$	$16 < t_r \leq 40$	$40 < t_r \leq 60$	$60 < t_r \leq 100$
	460	445	430	400
Fracture elongation min. in [%]	16-19			
Impact energy (J) min. on ISO-V specimens at -20°C [J=Nm] mean value from Three (3) individual specimens	L	40-45		
	T	27-30		

5.0 MATERIAL: SA 592 Gr F, ASTM A 592

5.1 CHEMICAL COMPOSITION

5.1.1 The chemistry shall be as per respective specification.

5.2 MECHANICAL PROPERTIES

5.2.1 Tensile strength, yield strength, % elongation at room temperature shall be carried out melt wise / heat treatment batch wise.

 Ranipet	Technical Delivery Condition (TDC) For IMPELLER RING,HUB DISC, SUPPORTING BODY & FAN FORGINGS. P355NH/QH of EN 10222-4, WSTE 500/ P500 NH of 1.8937, P460NH(1.8935) and SA 592 Gr.F of ASTM A 592	Doc Ref:	TDC:RTF:307
		Rev No:	05
		Date:	27.07.2015
		Page No:	4 of 6

5.2.1.1 Tensile test results shall meet the specification requirements. Tensile requirements as per below table –

	Product thickness (t≤65 mm)	Product thickness (65<t≤100mm)
Tensile strength, min [N/mm ²]	795 to 930	725 to 930
Yield strength, min [N/mm ²]	690	620
Elongation min, %	18	17
Reduction of area, min, %	45	40

Note: The maximum thickness of forging under this specification (ASTM A592) shall be 100mm for grade F.

5.2.2 Hot tensile test shall be carried out melt wise for impeller ring forgings only.

5.2.2.1 In case of SA 592 Gr. F, Hot tensile test shall be done at 400°C. Yield strength shall be 560 Mpa upto 65mm and 510 Mpa above 65mm.

5.2.2.2 Impact test: This test shall be conducted on 3 ISO V specimen melt wise / HT batch wise

5.2.2.3 In case of SA 592 Gr F impact test shall be conducted at 0°C. Lateral expansion opposite to notch shall not be less than 0.38 mm. Impact energy in joules shall be also be reported.

5.2.2.4 The ring for the mechanical testing shall be extended to accommodate the test specimen as per ASTM A 668.

6.0 FORGINGS

6.1 The forging shall be made from fully killed steel of fine grain practice. Suggested minimum forging reduction ratio of 4:1 from starting piece to finished forgings must be ensured.

6.2 Weld repairs are prohibited.

6.3 Impeller ring forgings may also be produced by ring rolling process.

6.4 The acceptance of our purchase order shall constitute your agreement to the following conditions:

- Chemical composition (ladle analysis) for each heat.
- Tensile strength, yield point, and fracture elongation shall be determined on at least one (1) specimen from each lot. Depending on the size of the part to be examined, removal of the specimens shall be in horizontal (L) or transverse (T) direction.

	Technical Delivery Condition (TDC) For IMPELLER RING, HUB DISC, SUPPORTING BODY & FAN FORGINGS. P355NH/QH of EN 10222-4, WSTE 500/ P500 NH of 1.8937, P460NH(1.8935) and SA 592 Gr.F of ASTM A 592	Doc Ref:	TDC:RTF:307
		Rev No:	05
		Date:	27.07.2015
		Page No:	5 of 6

- The impact energy shall be determined on three (3) ISO-V impact specimens at -20°C from each lot to be delivered.

The mean value derived from three (3) tests shall constitute the test result. The lowest individual value may not be below 2/3 of the required minimum value. Specimens may be taken in longitudinal or transverse direction.

7.0 NON-DESTRUCTIVE TESTING

7.1 All the forgings shall be ultrasonically tested radially and axially as per ASTM A 388.

7.2 ACCEPTANCE CRITERIA

Forgings Length	Radial Scanning	Axial Scanning
≤ 1 meter	3 mm equivalent reflector size by DGS method	3 mm equivalent reflector size by DGS method
> 1 meter	3 mm equivalent reflector size by DGS method	One or more discontinuities resulting in complete loss of back wall reflection to 10% of the full scale height not attributing to geometric configuration when tested by back wall echo method are not acceptable.

8.0 MARKING AND PRESERVATION

8.1 All forgings shall be marked with specification, melt No. and supplier's emblem legibly by hard stamping on the material surface. This area shall be framed with white paint for easy identification.

8.2 Forgings shall be applied with rust preventive coating.

9.0 INSPECTION & TEST CERTIFICATE

9.1 The items manufactured within India, shall be subjected to inspection by BHEL or authorized agency.

9.2 The supplier shall furnish the test certificate in English as per EN 10204. It shall contain the following information.

- PO No.
- Specification and grade
- Size, No. and weight
- Melt No.
- Heat treatment particulars
- Chemical composition - melt wise
- Mechanical properties
- TDC No.

 Ranipet	Technical Delivery Condition (TDC) For IMPELLER RING, HUB DISC, SUPPORTING BODY & FAN FORGINGS. P355NH/QH of EN 10222-4, WSTE 500/ P500 NH of 1.8937, P460NH(1.8935) and SA 592 Gr.F of ASTM A 592	Doc Ref:	TDC:RTF:307
		Rev No:	05
		Date:	27.07.2015
		Page No:	6 of 6

Record of Revisions

Rev No.	Clause Revised	Revision made	Date
00	---	original issue	27.06.94
01	1.1 1.3 2.0,2.1,2.4,3.1 2.2.1 2.3.2 2.4.2 4.2 7.2	StE500 V spec added hub disc & body forgings included New clause added Editorial Correction Forgings reduction ratio included Clause revised Impeller ring hot tensile strength empowered ASTM A 668 is included in place of ASTM 370 Packing requirements in case of Imported forgings added	25.12.94
02	--- 2.3 & 3.2 1.2,2.1.1,2.3.2 2.3.3	Change of name of WstE355V to P355NH/QH is and Corresponding Standard is included. Deleted & other clause numbers altered accordingly. clause modified	26.12.00
03	---	Totally modified	02.05.02
04	2.0 & 5.4 3.0 4.2.1.1 6.2	1. Required contents from TFN: 359, Rev:02, Dt: 17.02.2014 added. 2. For material P355NH/QH as per EN10222-4 chemical & mechanical properties added. 3. Tensile requirements for SA592 Gr.F-Table added. 4. NDT acceptance criteria revised.	05.08.14
05	----- 4	1. Header changed. 2. P460NH (1.8935) added.	27.07.15

 Ranipet	Technical Delivery Condition(TDC) For AP FAN BLADE SHAFT & FAN FORGINGS of 34 Cr M04 TQ + T of EN 10083 - 1 42 Cr M04 TO + T of EN 10083 - 1	Doc Ref:	TDC : RTF : 309
		Rev No.	03
		Date:	06.08.2014
		Page No.	1 of 4

10 SCOPE

1.1 This TDC specifies the requirements for the supply of Proof machined Forgings for use as AP fan blade shaft & Fan forgings.

2.0 MATERIAL AND PROCESS

2.1 The applicable specifications are:

SI.No.	Specn & grade as per EN 10083-1	Equivalent as per JIS Q4105
1)	34 Cr M04 TQ +T	SCM 435
2)	42 Cr M04 TQ +T	SCM 440

2.2 Applicable for new suppliers.



2.2.1 A sample shaft shall be manufactured for checking the flow lines and other Defects inline with ASTM E 381 and E 340 and for checking other requirements of this technical delivery conditions and shall be sent to BHEL for approval. The supplier shall start bulk production only after approval by BHEL.

2.3 Suggested Minimum forging reduction ratio of 4:1 from starting piece to finished forgings must be ensured.

2.3.1 The grain flow as shown in figure given below

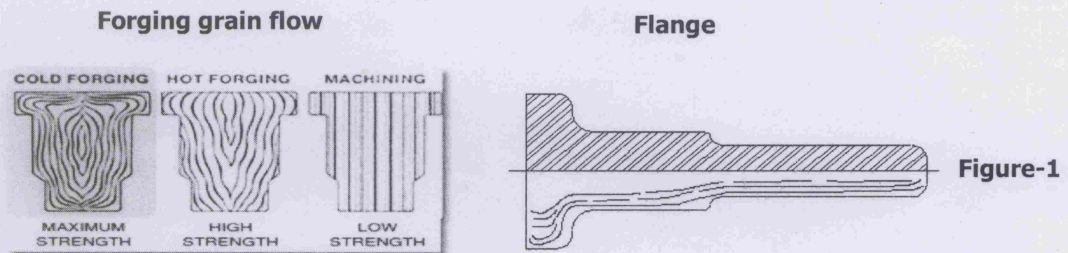
L - Longitudinal specimen

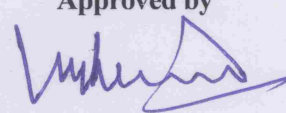
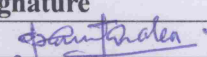
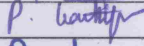
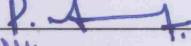

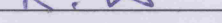
Prepared by 	Reviewed by	signature	Approved by  (Head/QA)
	ENGG(Fans)		
	QC(Proc)		
	MPL		
	PUR		
QA			
Issued by	QUALITY ASSURANCE		

 Ranipet	Technical Delivery Condition(TDC) For AP FAN BLADE SHAFT & FAN FORGINGS of 34 Cr Mo4 TQ + T of EN 10083 - 1 42 Cr Mo4 TO + T of EN 10083 - 1	Doc Ref:	TDC : RTF : 309
		Rev No.	03
		Date:	06.08.2014
		Page No.	2 of 4

3.0 Chemical & Mechanical Properties:

3.1 **Material:** 34 CrMo4 TQ + T, Material No. 1.7220, EN 10083-1

As-received condition: Forged, quenched and tempered (+ QT);
Pre-machined according to the dimensions in the drawing of the purchaser, with appropriate allowance for final machining as specified below (CI No. 4.0), UT inspected and stress relieved.

3.1.1 **Chemical composition:** Chemical composition shall be checked for each melt and it shall be as per the specification.

Chemical composition as per EN:10083-3 (cast analysis)

C	Si Max.	Mn	P Max.	S Max.	Cr	Mo
0.30 to 0.37	0.4	0.60 to 0.90	0.025	0.035	0.90 to 1.20	0.15 to 0.30

3.1.2 **Mechanical properties:**

Diameter (mm)	UTS (MPa)	0.2 % Yield Strength	% Elongation	Impact (In Joules ISO-V specimen)
40-100	800-900	550	14	45
100-160	750-900	500	15	45
160-250	700-850	450	15	45

3.2 **Material:** 42 Cr Mo 4 TQ + T, Material No. 1.7225, EN 10083-1

As-received condition: Forged, quenched and tempered (+ QT);
Pre-machined according to the dimensions in the drawing of the purchaser, with appropriate allowance for final machining as specified below (CI No. 4.0), UT inspected and stress relieved.

3.2.1 **Chemical composition:** Weight in %, as per EN: 10083-3 (cast analysis)

C	Si Max.	Mn	P Max.	S Max.	Cr	Mo
0.38 to 0.45	0.4	0.60 to 0.90	0.025	0.035	0.90 to 1.20	0.15 to 0.30

3.2.2 **Mechanical properties:** To be determined on longitudinal (L) or transverse (T) specimens at room temperature except for the impact energy, which shall be determined at -20°C.



Ranipet

Technical Delivery Condition(TDC)
For
AP FAN BLADE SHAFT & FAN
FORGINGS
of
34 Cr Mo4 TQ + T of EN 10083 - 1
42 Cr Mo4 TQ + T of EN 10083 - 1

Doc Ref: TDC : RTF : 309

Rev No. 03

Date: 06.08.2014

Page No. 3 of 4

For forgings and rolled stock	For product thickness in [mm]			
	up to 100	101 – 250	251 – 500	501 – 750
Yield point $R_{p0.2}$ min [N/mm ²]	650	500	460	390
Tensile strength R_m [N/mm ²]	900 – 1100	750 – 950	690 – 840	590 – 740
Fracture elongation A_{min} [%]	L	12	13	15
	T	10	10	11
Impact energy KV_{min} on ISO-V specimen at $-20^{\circ}C$ [J = Nm]	28	27	26	25
Brinell hardness	265 – 330	220 – 280	200 – 250	175 – 220

4.0 PRE-MACHINED CONDITION

After heat treatment, the part shall be pre-machined on all sides with the specified allowance for final machining.

The allowance shall be determined by the length as shown in the following table.

To achieve sufficient contact for the probes during the ultrasonic inspection, the surface of the forgings shall be pre-machined to a surface roughness of $R_z \leq 63$ [μm].

Length in [mm]	≤ 2000	2001 – 2500	2501 – 3000	> 3000
Cutting allowance DR in [mm]	5	6	7	8

5.0 HEAT TREATMENT

5.1 All the forgings shall be supplied in quenched and tempered condition (TQ + T condition).

6.0 TEST SAMPLE & MECHANICAL PROPERTIES

6.1 Testing of mechanical properties shall be by using specimen from finish heat treated shafts. Specimen shall be taken at a depth of at least $1/4^{th}$ of diameter from surface.

6.2 Test specimens shall be selected melt wise and heat treatment lot wise.

6.3 The chemical and mechanical prosperities shall be as per tables as applicable.

7.0 NON-DESTRUCTIVE TESTING

7.1 Shafts shall be ultrasonically tested radially and axially as per ASTM A 388.

7.2 Acceptance criteria:

Forgings Length	Radial Scanning	Axial Scanning
≤ 1 meter	3 mm equivalent reflector size by DGS method	3 mm equivalent reflector size by DGS method
>1 meter	3 mm equivalent reflector size by DGS method	One or more discontinuities resulting in complete loss of back wall reflection to 10% of the full scale height not attributing to geometric configuration when tested by back wall echo method are not acceptable.

	Technical Delivery Condition(TDC) For AP FAN BLADE SHAFT & FAN FORGINGS of 34 Cr Mo4 TQ + T of EN 10083 - 1 42 Cr Mo4 TO + T of EN 10083 - 1	Doc Ref:	TDC : RTF : 309
		Rev No.	03
		Date:	06.08.2014
		Page No.	4 of 4

8.0 REPAIR

8.1 Repair involving fusion welding is prohibited.

9.0 IDENTIFICATION & PRESERVATION

9.1 All the forgings shall be packed in a box and box shall be identified with specification, melt no, suppliers emblem & P.O number. Rust preventive coat of dry resin type shall be applied on the blade shaft to avoid atmospheric corrosion.

10.0 INSPECTION & TEST CERTIFICATE

10.1 The items manufactured within India, shall be subjected to inspection by BHEL or authorised agency.

10.2 The supplier shall furnish the test certificate in English. It shall contain:-

- | | |
|-----------------------------|---|
| (a) PO and Date | (e) Heat treatment particulars |
| (b) Specification and grade | (f) Chemical composition- melt wise |
| (c) Size, No. and weight | (g) Mechanical properties- melt wise/heat treatment |
| (d) Melt no. | (h) Ultrasonic test report (CI No.7.0) |
| | (i) TDC No. |

Record of revisions

Rev No	Clause revised	Revision made	
00	--	Original issue	11.07.94
01	--	42CrMo4 TQ+T of EN 10083-4 is added Table for mechanical properties added for 34CrMo4 & 42CrMo4	30 06 96 -
02		Totally modified	02.05.02
03	3.2.2 3.1.1 & 3.2.1 7.2	1. 42CrMo4 latest Mechanical properties details added from TLT documents AM015, Drg. No. 4GK 8085d. 2. Chemical composition as per EN:10083- 3 for both materials 34 CrMo4 & 42CrMo4 added. 3. Acceptance criteria for UT updated.	06.08.14

Online SRF Submission Procedure

We are pleased to inform you to register your firm thro' the following link.

Following are the formalities to be completed by your company for registration purpose.

Recently, we have switched over to online Supplier Registration Form as per our corporate guidelines. Supplier Registration Form is to be fed in our BHEL website portal and download the Supplier Registration Form from online portal and the same is to be sent to us for processing your registration activity.

We request to visit our Web Site : www.bhel.com and click under heading "Supplier Registration" and fill up the "**Supplier Registration Form**" which is available in the Online Supplier Registration Portal.

Or else, copy the following URL Link and paste in the web link address: http://www.bhel.com/vender_registration/vender.php and proceed with.

Or else, type directly as <http://203.129.195.108> and then before proceeding for user id & password - please search thoroughly your required material / product under the "search material" - click it and go for BHEL Plant name ie., BAP Ranipet in this case and then type under description any four letters or so for which *product / item* you are looking for and note down the *corresponding product code number suitably*.

*After completing the material search thoroughly then proceed for User Id & Password for filling up the details of registration requirements. Note: If you are an already registered supplier with any of our BHEL Unit - pls select "**existing permanent supplier**" or else select "**New Registration**" and then proceed accordingly.*

Please note that for foreign suppliers there is a separate format to be filled in, which may be taken care suitably.

After successful submission (uploading) of all the relevant documents thro' online portal, a hard copy of the same with all the annexures (as called for) may please be taken a print out and make a document folder and send the same to undersigned after affixing authorized signature with company seal in all pages.

Looking for a long successful & sustaining business association with BHEL.

DRAWING NO. 3-55-228-01655

ALL DIMENSIONS ARE IN MILLIMETRES FOR PRODUCTION
 REF. PR-QA-590 FOR PAINTING
 REF. PR-QA-508 FOR UNTOLO DIMS
 REF. APPLICABLE QMS FOR MATCODE&SPEC.

3.2 / 6.3

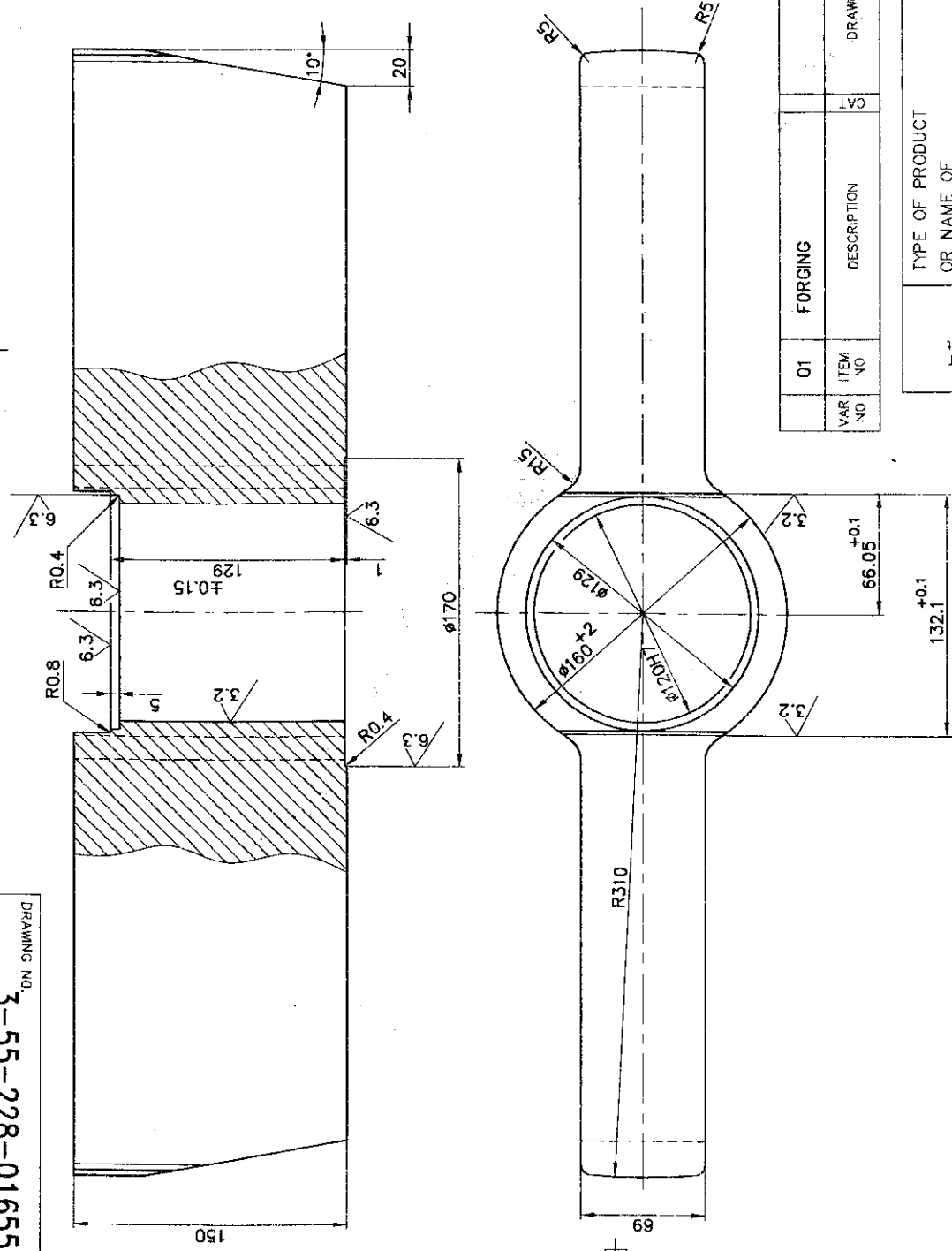

φ120H7	+0.035 0.000
DIMENSION	TOLERANCE

01	FORGING	920374770100	45.700
VAR NO	DESCRIPTION	ITEM NO	UNIT WT
		P.355NH	1
		MATL CODE	QTY
		MATL SPECN	
		A	
		B	
		C	
		DI	
		CS	
		ZONE	

TYPE OF PRODUCT OR NAME OF CUSTOMER/PROJECT

BHARAT HEAVY ELECTRICALS LTD.,
 UNIT: BOILER AUXILIARIES PLANT,
 RANIPET - 632 408.

DRN: A.SAMU.O/L
 CHD: MAHESH
 APPD: K.K.N.

DATE: 22.02.12

SCALE: NTS

WEIGHT (KG): 45.700

REF. TO ASSY/OLD DRG.: V7008188 b

DEPT: FANS
 CODE: 864

GRADE OF UNTOLO DIM: PR-QA-500

TITLE: COUNTER WEIGHT

CARD CODE: U 01

DRAWING NO. 3-55-228-01655

REV: 01

CAUTION: The information on this document is the property of BHARAT HEAVY ELECTRICALS LTD. It must not be used directly or indirectly in any way detrimental to the interest of the company.

REV/DATE	ALTERED	MAHESH
01	05.09.12	CHECKED P.M.J
ZONE	MATL CODE ADDED AND DESC & MATL SPEC ALTD FOR ITEM NO.01 AS SHOWN IN BOM.	

